

Hup 32-27

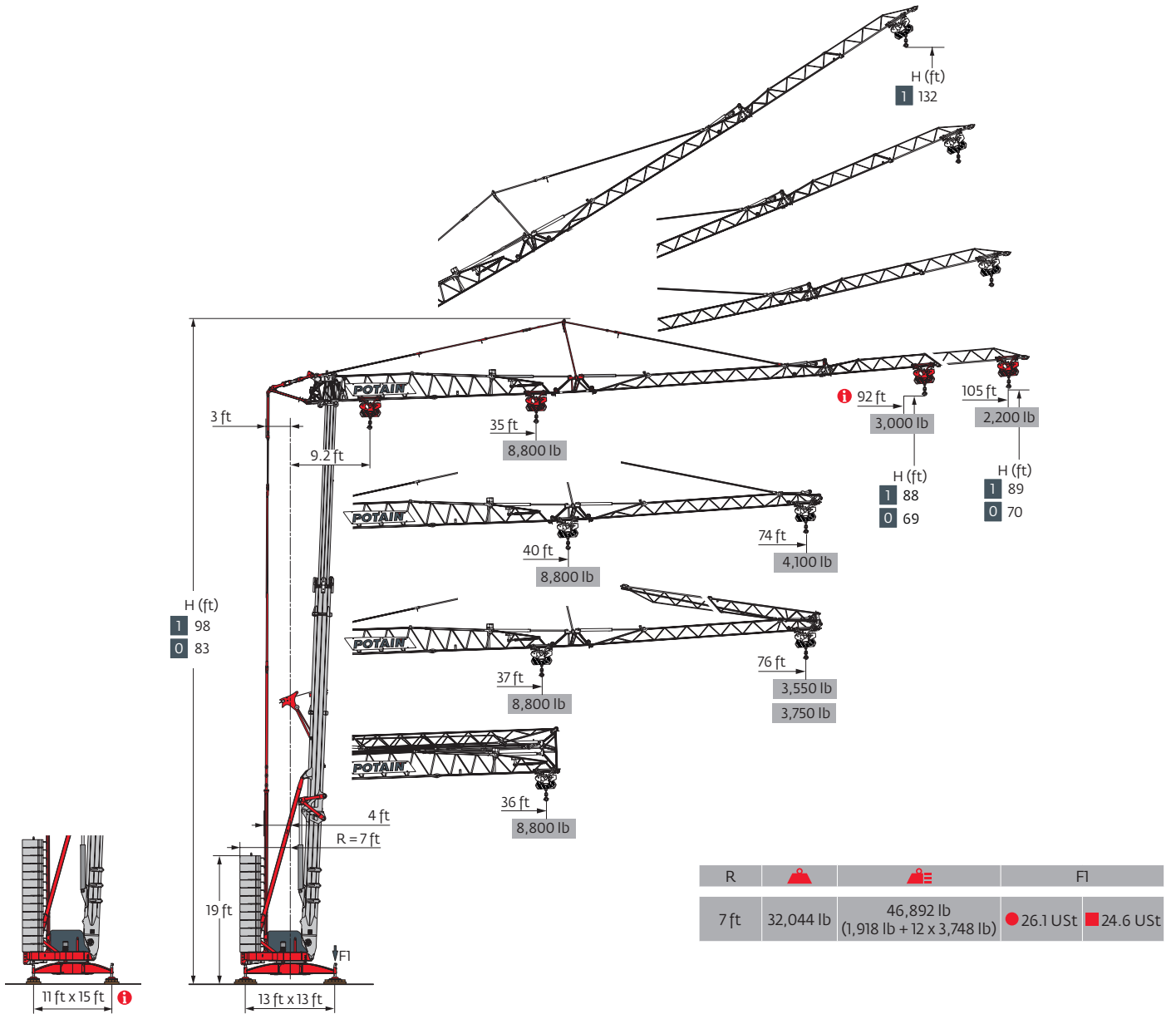

Load curves

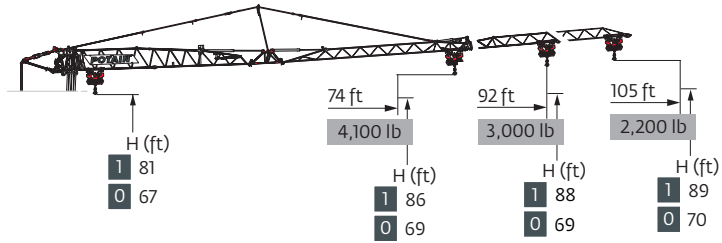
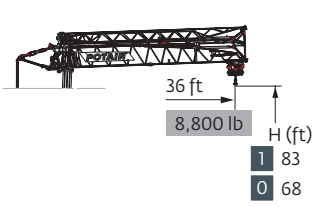

105 ft	9.2	▶	36	ft	9.2	▶	35	36	39	43	46	49	52	56	59	62	66	72	82	89	98	105	ft
▲▲▲▲	▼		8,800	lb			8,800	8,550	7,650	6,900	6,300	5,800	5,350	4,950	4,600	4,300	4,050	3,600	3,050	2,750	2,400	2,200	lb
92 ft	9.2	▶	36	ft	9.2	▶	38	39	43	46	49	52	56	59	62	66	72	82	89	92	ft		
▲▲▲▲	▼		8,800	lb			8,800	8,550	7,700	7,050	6,450	5,950	5,550	5,150	4,850	4,550	4,050	3,450	3,100	3,000	lb		
74 ft	9.2	▶	36	ft	9.2	▶	40	43	46	49	52	56	59	62	66	74	ft						
▲▲▲▲	▼		8,800	lb			8,800	8,100	7,400	6,800	6,250	5,800	5,450	5,100	4,750	4,100	lb						



105 ft	9.2	▶	37	39	43	46	49	52	56	59	62	66	72	76	ft
▲▲▲▲	▼		8,800	8,050	7,300	6,650	6,100	5,650	5,250	4,850	4,550	4,250	3,800	3,550	lb
92 ft	9.2	▶	38	39	43	46	49	52	56	59	62	66	72	76	ft
▲▲▲▲	▼		8,800	8,500	7,700	7,050	6,450	5,950	5,550	5,150	4,850	4,550	4,050	3,750	lb

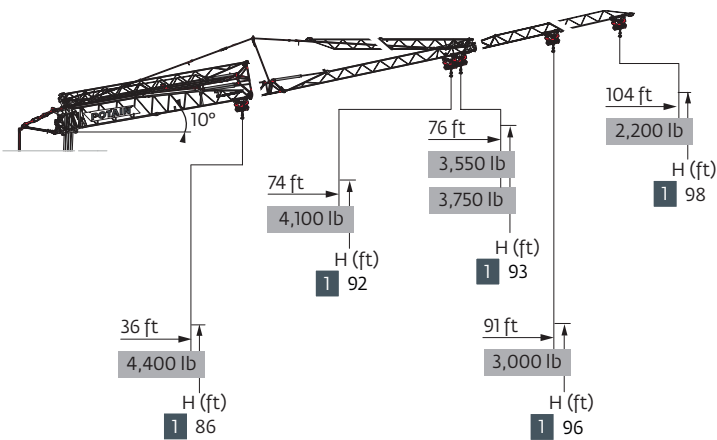





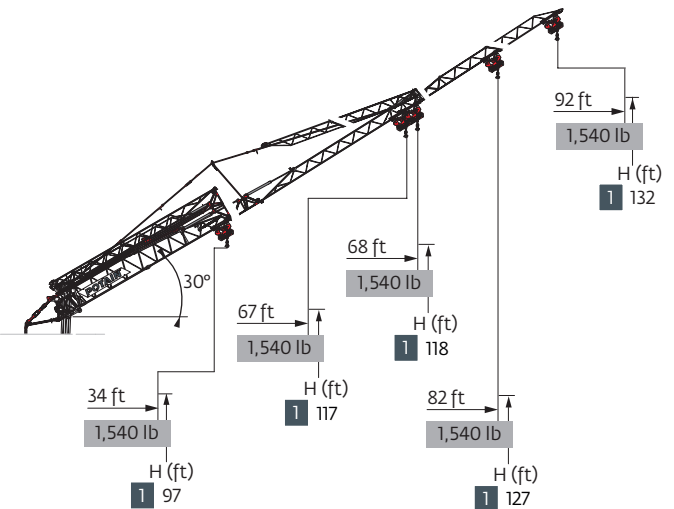
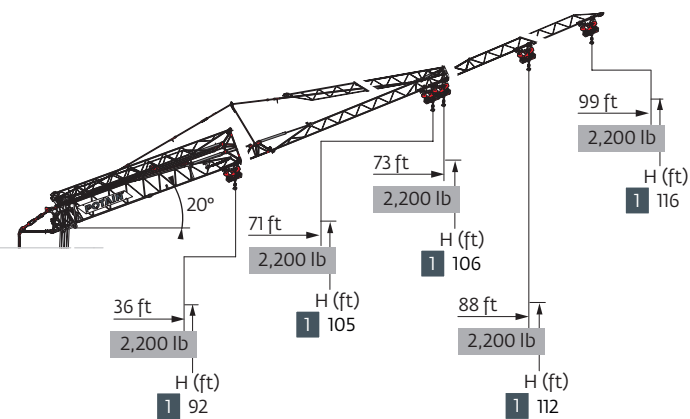

105 ft	9.2	▶	60	62	66	72	82	89	98	104	ft
▲▲▲▲	▼		4,400	4,250	4,000	3,550	3,000	2,700	2,350	2,200	lb
92 ft	9.2	▶	66	72	79	91	ft				
▲▲▲▲	▼		4,400	3,950	3,550	3,000	lb				
74 ft	9.2	▶	69	72	74	ft					
▲▲▲▲	▼		4,400	4,200	4,100	lb					

105 ft	9.2	▶	63	66	72	76	ft
▲▲▲▲	▼		4,400	4,250	3,750	3,550	lb
92 ft	9.2	▶	66	72	76	ft	
▲▲▲▲	▼		4,400	4,000	3,750	lb	
105-92-74 ft	9.2	▶	36	ft			
▲▲▲▲	▼		4,400	lb			



Mechanisms

480 V - 60 Hz								hp	kW
	18 HPL™ 10	fpm	6.9	62	118	190	213	18	13
		lb	8,800	8,800	4,400	2,200	1,100		
	3 DVF 5	fpm	3 → 148 (0 → 2,200 lb) 3 → 135 (2,200 lb → 8,800 lb)					3	2.2
	HPS 141	rpm	0 → 0.9					5	3.7

 IEC 60204-32		
480 V (+6% -10%) 60 Hz	19 → 13 kVA	

Erection

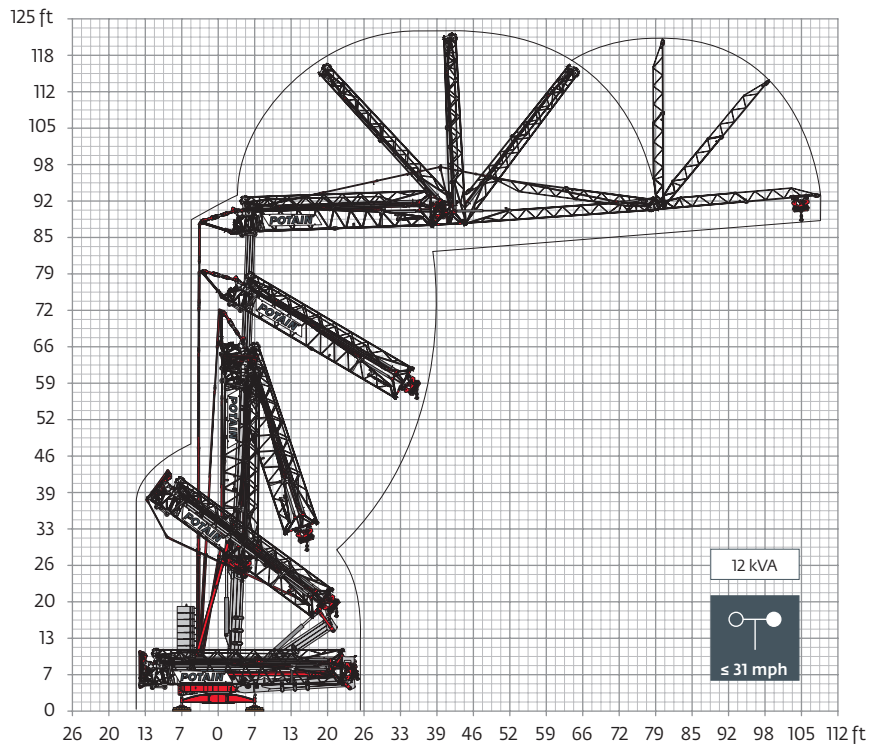

Transport

DS62/S120 - 6 mph

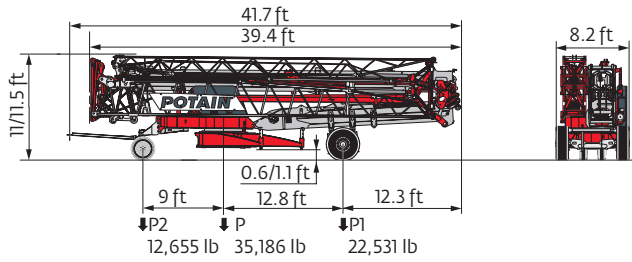

DJ105A/S125A - 15.5 mph

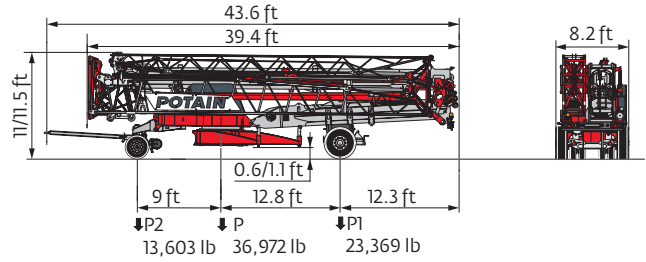

DJ126MA/S125A - 15.5 mph

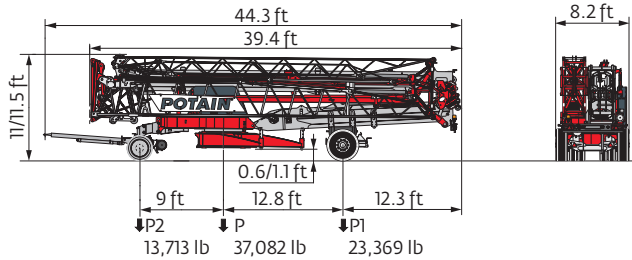

North America Highway Axle

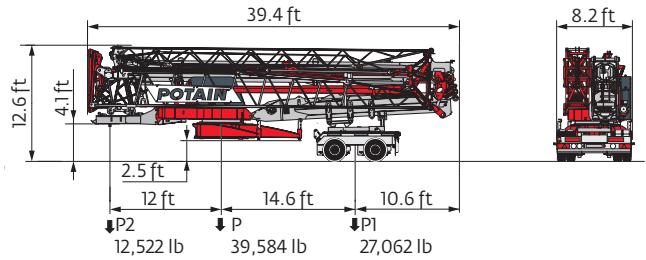

Container 40' Open Top High Cube



The reactions meet the EN 14439 and ASCE 7-10 specifications for "out of service" wind conditions, provided the illustrated wind speed matches required design wind speed for the location of the tower crane. The "out of service" design wind speed was determined in accordance with ASCE 7-10, Figure 26.5-1A. The wind velocity, used for this configuration was 98 mph (158 kph), which represents a nominal design 3-second wind gust at 33 ft (10 m) above ground for Exposure B category. A factor of 0.85 was applied to the 700-year ultimate design wind speed of 115 mph (185 kph), per ASCE 37-02, with the assumption that this crane is considered a temporary structure used during a construction period of 2 years or less.

- R Rear slewing radius
- i Consult us
- Reactions in service
- Reactions out of service
- ▲ Weight without load, without ballast, without transport axles, with max. jib and standard height
- ▲ Total ballast weight
- Standard equipment
- Options
- Hoisting
- Trolleying
- Slewing
- kVA Required power

Power Control Function: winch speeds adapted to the available power

Hook heights given with plated pulley block
 This commercial document is not legally binding
 For any technical information, please refer to the corresponding instructions

