

NATIONAL WIRELINER SUPPORT UNITS



NATIONAL SERIES 875 WIRELINE SUPPORT UNIT

National introduced truck-mounted telescoping booms to the Well Service market in 1977 and since that time has continually improved its products to meet the needs of the industry. As a National owner, you can be assured that you will receive a well-engineered, well-manufactured, and fully tested machine designed for your application.

At National, we believe that our future depends on the success of the customers and industries we serve and the quality of the products we provide. Our commitment to quality is our pledge to provide our customers with reliable products designed to provide years of service.

We are happy to be a part of the Well Service industry and look forward to the success and growth of this market in the coming years.

- **Payload Space.** The compact design of the 875 wireline support unit permits increased payload space and capacity compared to mast units.
- **Maneuverability.** The precise positive no-drift planetary rotation system of the 875 permits exact sheave placement over the well-head.
- **Setup Time.** Uncomplicated single lever control of each function (lift, telescope and rotation systems) provides simplified boom set-up and boom stowing.
- **Full Hydraulic Boom.** The 4-section fully hydraulic boom telescopes to its 75 ft. extension in one uninterrupted operation.
- **Four Plate Boom Design.** Boxed construction utilizing heavier top and bottom plates for extra strength and minimum boom deflection.
- **Auxiliary Winch.** Heavy duty 1,500 lb. (bare drum single line pull) winch is located under the boom in front of the operator for easy visibility.
- **Jib.** An optional side-folding, swing-around jib with weld-on wireline sheave case adds 19 ft. to boom length.
- **Wireline Sheave Case.** Designed specifically for wireline use. Sheave case is an integral part of final stage boom and jib. No special pinning required.
- **Versatility.** Machine can be used for other lifting operations when not in wireline use.
- **Outriggers.** Massive "A" frame arms that spread 18' provide a wide stance and better leveling on uneven ground.
- **Holding Valves.** All holding valves are mounted directly to the cylinder for added safety in the event of hose failure.
- **Shear Plate Mounting.** Bolts to the neutral member of the truck frame in a manner recommended by truck chassis manufacturers. Provides increased truck frame life with positive no-shift installation.



NATIONAL SERIES 666A WIRELINE SUPPORT UNIT

- **Payload Space.** The compact design of the 666A wireline support unit permits increased payload space and capacity compared to mast units.
- **Maneuverability.** The precise positive no-drift rotation system of the 666A permits exact sheave placement over the well-head.
- **Setup Time.** Uncomplicated single lever control of each function (lift, telescope and rotation systems) provides simplified boom set-up and boom stowing.
- **Full Hydraulic Boom.** The 3-section fully hydraulic boom telescopes to its 66 ft. extension in one uninterrupted operation.
- **Four Plate Boom Design.** Boxed construction utilizing heavier top and bottom plates for extra strength and minimum boom deflection.
- **Auxiliary Winch.** Heavy duty 1,500 lb. (bare drum single line pull) winch is located under the boom in front of the operator for easy visibility.
- **Wireline Sheave Case.** Designed specifically for wireline use. Sheave case is an integral part of final stage boom. No special pinning required.
- **Versatility.** Machine can be used for other lifting operations when not in wireline use.
- **Outriggers.** Massive "A" frame arms that spread 18' provide a wide stance and better leveling on uneven ground.
- **Holding Valves.** All holding valves are mounted directly to the cylinder for added safety in the event of hose failure.

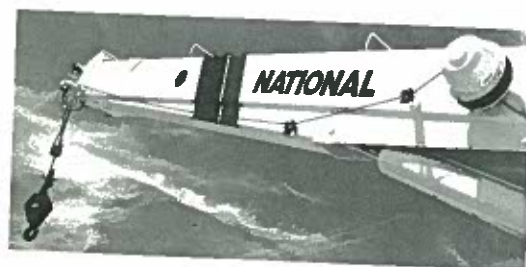

National's anti two block system is standard on all National cranes (as of June 1, 1986). Photos in this brochure taken prior to that date may not show the crane equipped with the current standard anti two block protection system.

875 WIRELINE PROOF TEST DATA

*A proof test is a one time test conducted at loads substantially higher than maximum rated capacities under closely controlled conditions on a new or reconditioned "like-new" unit.

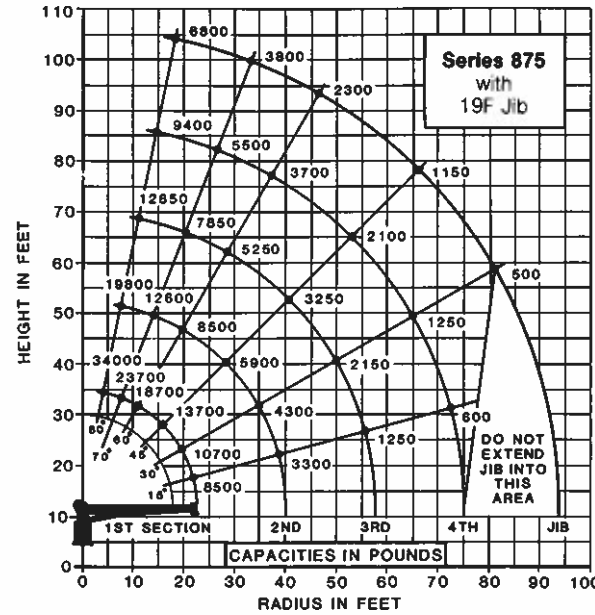
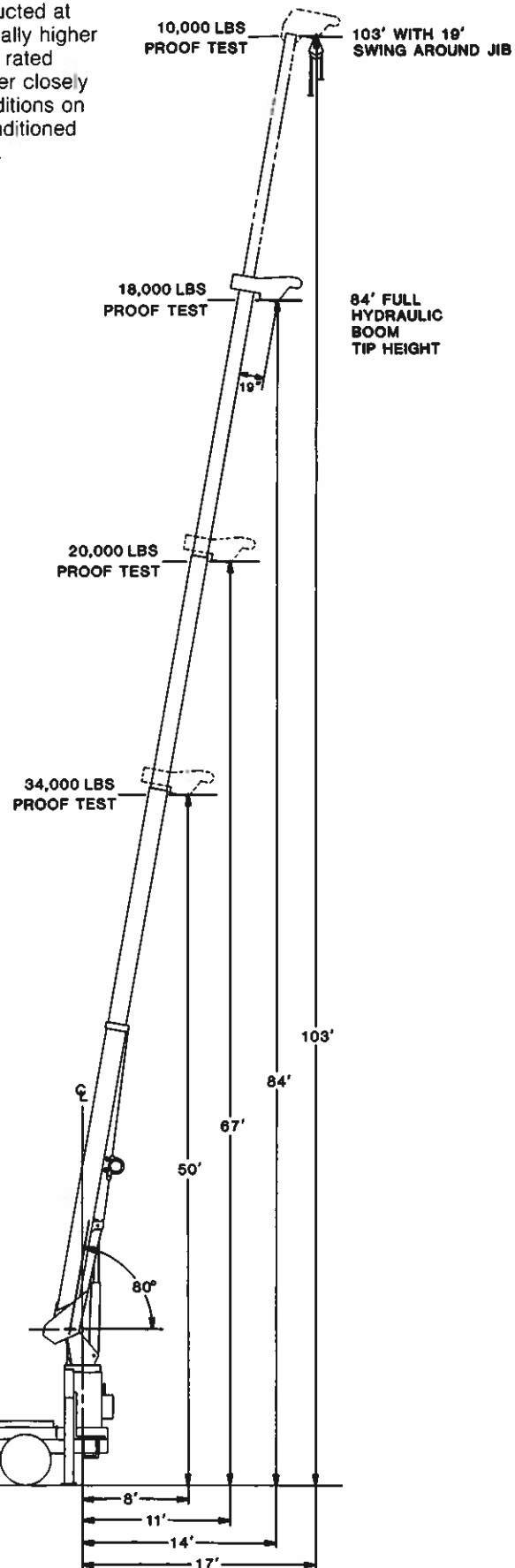

Do not operate cranes or accessories within 10 feet of live power lines.

1. Load ratings shown are maximum allowable loads with the outriggers properly extended on a firm, level surface and the crane leveled and mounted in a factory-recommended configuration.
2. Always level the crane with the level indicator located on the crane frame.
3. The operator must reduce loads to allow for factors such as wind, ground conditions, operating speeds and the effect of freely suspended loads.
4. Overloading the crane may cause structural collapse or instability.
5. Weights of any accessories attached to the boom or load-line must be deducted from the load chart capacities.
6. Do not exceed jib capacities at any reduced boom length.

Planetary Winch Data

Caution

Do not dead head line block against boom tip when extending boom. Keep at least 3 wraps of line on drum at all times. Use only 9/16" diameter 8 x 19 or 8 x 25 IWRC cable on this machine. Average breaking strength of wire rope 29,750 pounds. Maximum allowable 3.5:1 line pull at design factor is 8,400 pounds.

	1 Part Line	2 Part Line	3 Part Line	4 Part Line
Std. Speed Std. Line Pull	164 F.P.M. 7,500 Lbs.	82 F.P.M. 15,000 Lbs.	55 F.P.M. 22,500 Lbs.	41 F.P.M. 34,000 Lbs.
*Burst-of-Speed Line Pull	265 F.P.M. 3,000 Lbs.	132 F.P.M. 6,000 Lbs.	88 F.P.M. 9,000 Lbs.	66 F.P.M. 12,000 Lbs.

All winch pulls and speeds are shown on the third layer. Winch pulls would increase on the first and second layers. Winch line speeds would decrease on the first and second layers. Winch line pulls may be limited by the winch capacity or the OSHA 3.5 to 1 cable safety factor. These are shown below:

Winch	Bare Drum Pull	Allowable Cable Pull
Standard Planetary	10,200 pounds	8,400 pounds

*Ratings are based on intermittent use. High cycle applications may require optional oil cooler.

875 WIRELINE PROFILE DIMENSIONAL DRAWING

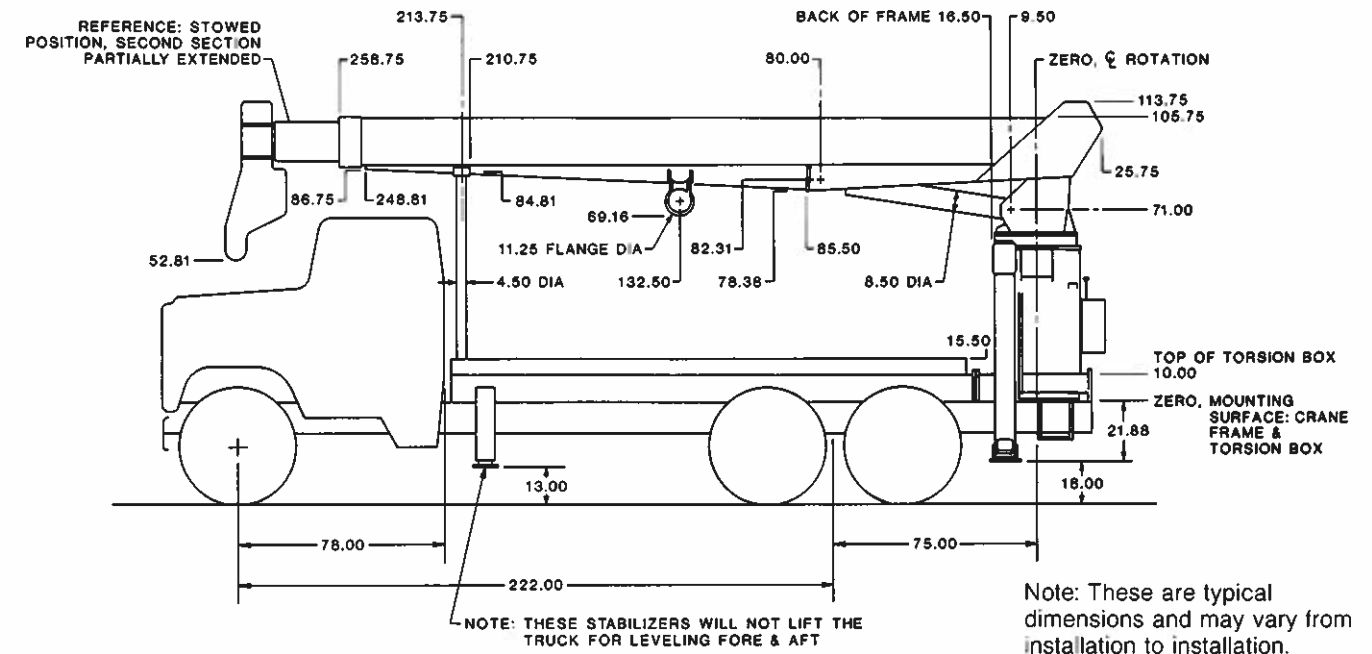

875 WIRELINE PLAN VIEW DIMENSIONAL DRAWING

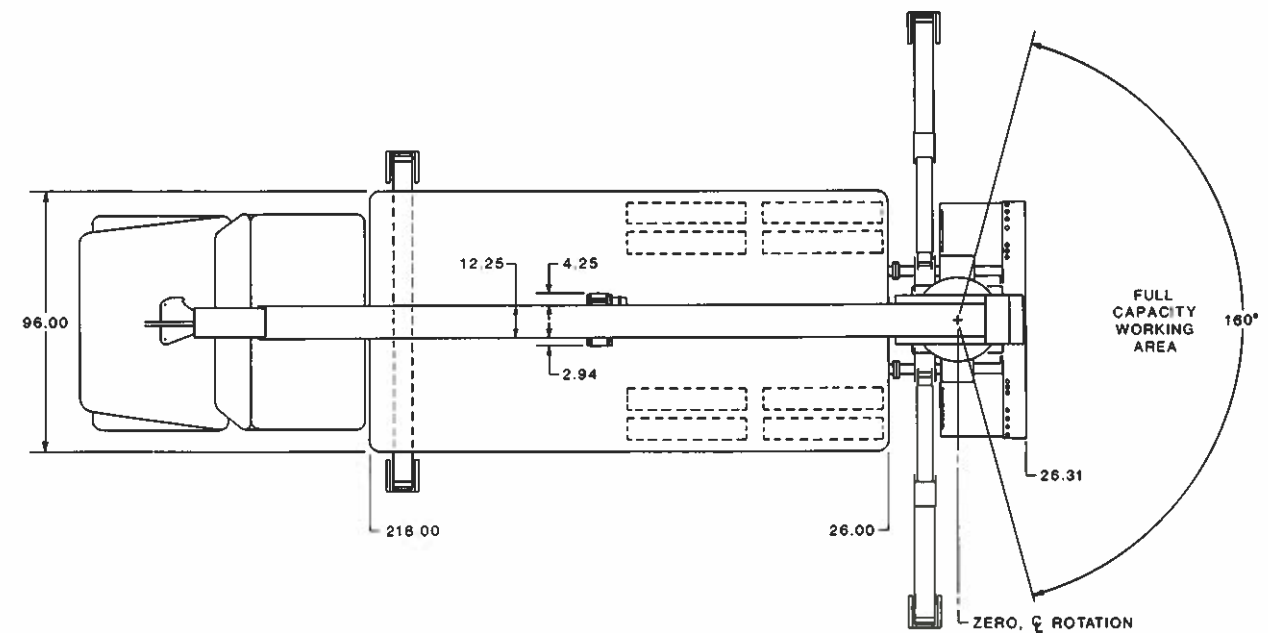

NATIONAL SERIES 875 WIRELINE SUPPORT UNIT PAYLOAD CAPACITIES

Ford LT8000 Chassis

	Curb Weight	Gross Vehicle Weight Rating
Front axle.....	7,500 lbs.	16,000 lbs.
Rear axle.....	7,000 lbs.	34,000 lbs.
Total.....	14,500 lbs.	50,000 lbs.

875 Wireline

Basic unit.....	8,520 lbs.
Special heavy duty torsion box.....	2,250 lbs.
875 boom.....	7,700 lbs.
19' wireline jib.....	800 lbs.
16' wood bed.....	1,145 lbs.

ASH (WL) stabilizers.....	840 lbs.
Counterweight.....	6,000 lbs.
Miscellaneous.....	1,185 lbs.
Total crane weight.....	28,440 lbs.

Total truck weight.....	14,500 lbs.
Total crane weight.....	28,440 lbs.
Total wireline unit weight.....	42,940 lbs.

Payload

GVWR.....	50,000 lbs.
Wireline unit weight.....	(42,940)
Total cargo bed payload.....	7,060 lbs.*

*Payload capacities will vary depending upon chassis, hardware, and mounting variations.

NATIONAL SERIES 875 WIRELINE SUPPORT UNIT MINIMUM TRUCK SPECIFICATIONS

Wheelbase (WB).....	222"
Cab to trunnion (CT).....	144"
Front axle weight rating (FA).....	16,000 lbs.
Front axle suspension rating (FA susp).....	16,000 lbs.
Rear axle weight rating (RA).....	34,000 lbs.
Rear axle suspension rating (RA susp).....	34,000 lbs.
Hendrickson RU-340.....	34,000 lbs.
Front axle tires (FA tires).....	15:00x22.5 16 ply Flotation
Front axle wheel type (FA wheel).....	Cast (spoke) or 10 hole, steel disc
Rear axle tires (RA tires).....	10:00x20 12 ply rating
Rear axle wheel type (RA wheel).....	Cast (spoke) or 10 hole, steel disc
Gross vehicle weight rating (GVWR).....	50,000 lbs.
Frame section modulus (SM).....	15.9 in. ³
Frame PSI yield (Yield).....	110,000 PSI
Engine (diesel).....	210 net horsepower @ 2800 RPM V-8 Caterpillar Model 3208

The above specifications are representative of the chassis shown in this booklet.

Transmission.....	Fuller Model RT 6613 13-spd. manual shift
Fuel tanks.....	Dual 50-gal. capacity
Power steering.....	Hydraulic
Alternator.....	70 amp output maximum
Battery.....	(2) Maintenance free 12 volt 93 amp/hr. rating
Brake system.....	Air brakes Dual air system
Miscellaneous.....	Solid white paint Ether cold starting device Front tow hooks Bostrom seats Heavy duty clutch

666A WIRELINE PROOF TEST DATA

*A proof test is a one time test conducted at loads substantially higher than maximum rated capacities under closely controlled conditions on a new or reconditioned "like-new" unit.

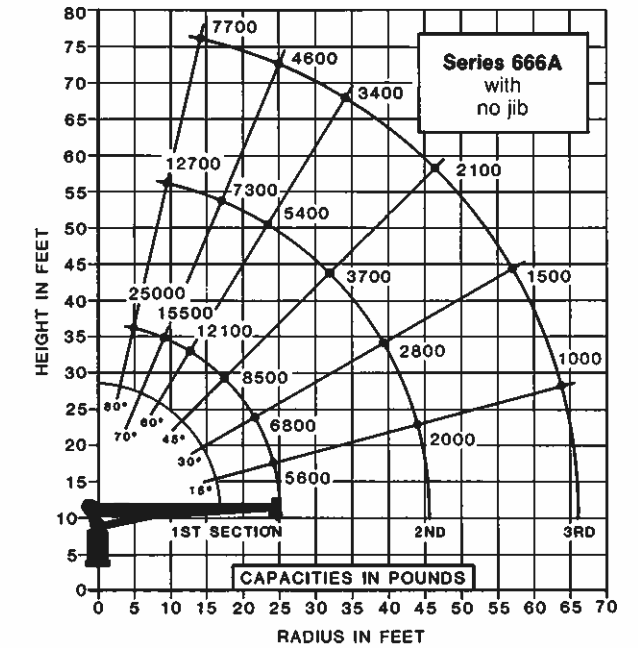
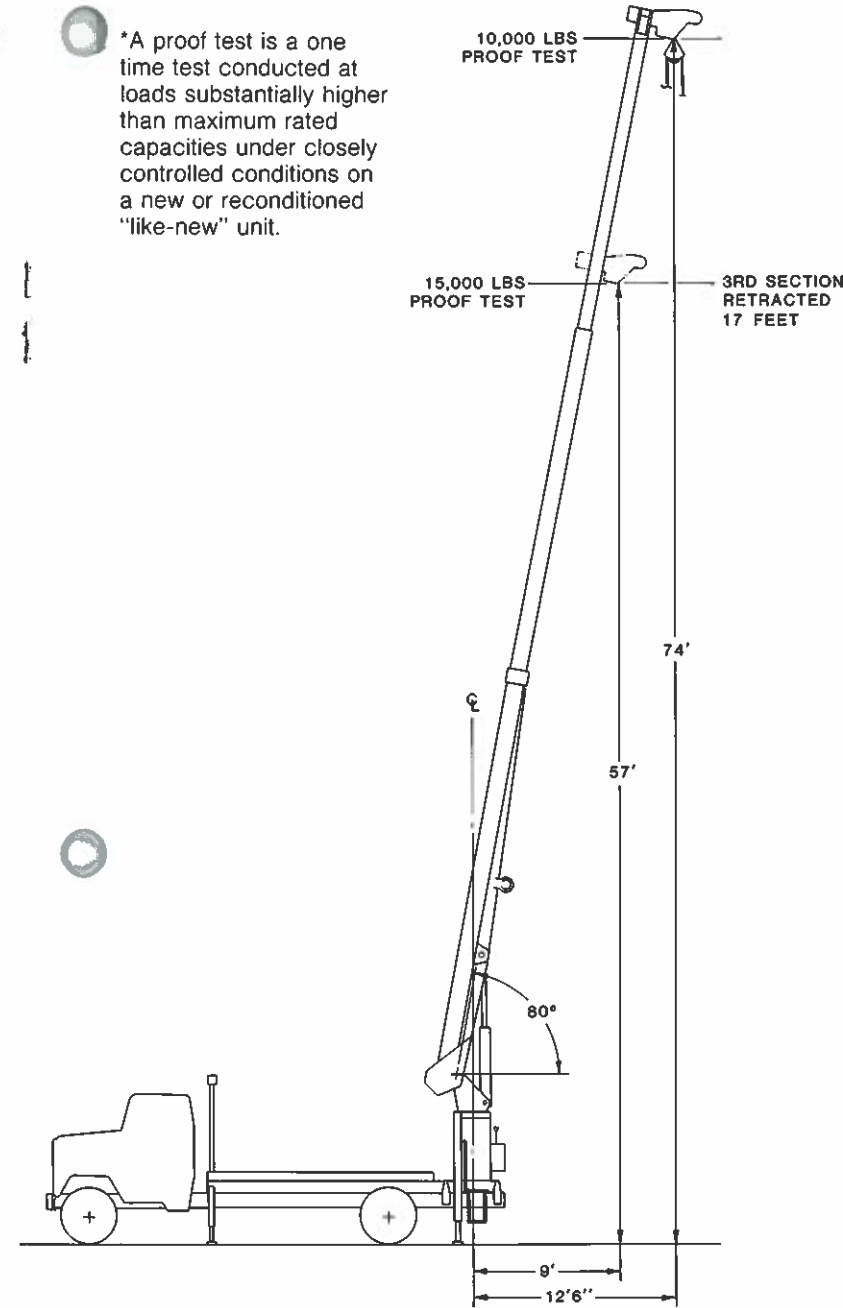

Do not operate cranes or accessories within 10 feet of live power lines.

1. Load ratings shown are maximum allowable loads with the outriggers properly extended on a firm, level surface and the crane leveled and mounted in a factory-recommended configuration.
2. Always level the crane with the level indicator located on the crane frame.
3. The operator must reduce loads to allow for factors such as wind, ground conditions, operating speeds and the effect of freely suspended loads.
4. Overloading the crane may cause structural collapse or instability.
5. Weights of any accessories attached to the boom or load-line must be deducted from the load chart capacities.
6. Do not exceed jib capacities at any reduced boom length.

Planetary Winch Data

Caution

Do not dead head line block against boom tip when extending boom. Keep at least 3 wraps of line on drum at all times. Use only 9/16" diameter 8 x 19 or 8 x 25 IWRC cable on this machine. Average breaking strength of wire rope 29,400 pounds. Maximum allowable 3.5:1 line pull at design factor is 8,400 pounds.

	1 Part Line	2 Part Line	3 Part Line
Std. Speed Std. Line Pull	7,500 Lbs. 164 F.P.M.	16,800 Lbs. 75 F.P.M.	25,000 Lbs. 50 F.P.M.
*With Optional Burst-of- Speed Feature	3,000 Lbs. 240 F.P.M.	6,000 Lbs. 120 F.P.M.	9,000 Lbs. 80 F.P.M.

All winch pulls and speeds are shown on the third layer. Winch pulls would increase on the first and second layers. Winch line speeds would decrease on the first and second layers. Winch line pulls may be limited by the winch capacity or the OSHA 3.5 to 1 cable safety factor. These are shown below:

Winch	Bare Drum Pull	Allowable Cable Pull
Standard Planetary	10,200 pounds	8,400 pounds

*Ratings are based on intermittent use. High cycle applications may require optional oil cooler.



Rear view demonstrates the wide 18' stance of the mainframe outriggers. These quickly stow within 96" for fast take-down for transport.

THE NATIONAL WIRELINE SUPPORT UNITS PUT TO THE TEST

- National tests are based on product standards unsurpassed in the commercial truck-mounted crane industry.
- Precise strain gage testing reveals infinitesimally small metal stretching or deformation.
- 20,000 full-lift life-cycles at rated load are completed prior to releasing a new product model for manufacture.
- Over 400 individual quality control inspections are made during manufacture and assembly.
- All telescoping boom sections are ultrasonically tested for weld penetration.
- National Crane top-level management staff conducts random quality audits of products prior to shipping.

Like all products manufactured by National Crane Corporation, the 875 and 666A Wireline Support Units have been subjected to National's unique and demanding testing procedures.

The testing of a new boom design typically begins by painting the boom sections with a "brittle lacquer," a plastic-based coating with virtually no elastic qualities. After loading a boom that has been coated with this substance, the test engineer visually inspects the coating for cracks. The lacquer fractures perpendicularly to the direction of stretching or deformation in the metal.

Although not precise enough for a final evaluation, this method shows the test engineers where to place the next step in the process—strain gages. These gages are tiny chips printed with electronic circuitry. As the metal being tested stretches or deforms, the circuitry expands or contracts with the movement. This causes minute changes in electrical resistance. These are measured by the strain gage monitor and printed out for technicians to study.

The strain gages used at National Crane measure resistance fluctuations as small as one-millionth of an ohm, and will determine metal deformation as small as one-millionth of an inch. Thirty-pound-per-square-inch stress will cause that amount of deformation.

The cost of each installed strain gage is estimated at \$25. In the testing and analysis of data of the National Series 800, more than 700 strain gages were applied, with approximately 2,500 man-hours invested. Basic testing of the Series 800 took nearly six months.

National's life-cycle testing involves putting a prototype unit through repeated

cycles of a particular function to determine how long it will operate as intended. When establishing its original standards for product durability, National carefully evaluated competitive machines and their performances. When National engineers had determined the best performances they were seeing from competitive products, they set their own standard—*more than 50% higher!* That is the test all National products must pass today.

Following strain gage testing, the procedure moves into the life-cycle testing mode. Maximum load figures for the unit are calculated, and the crane is operated at full-load through the cycle under close scrutiny. In the case of a boom test, the load is typically lifted six inches off the floor and then lowered, over and over, until the cycle test standard has been met. This procedure usually requires three or four days. For testing outriggers, frames, and the like, the unit is typically loaded and rotated through a complete range of motion for the prescribed number of cycles. This takes weeks to complete.

In the case of the Series 875 and Series 666A Wireline Support Units, National engineers conducted numerous additional tests. They installed additional strain gages to the booms, crane frames, torsion boxes, truck frames, and the angled stabilizers. These gages were monitored during the proof tests and the results of the tests were evaluated in the light of the data collected during the testing of the basic Series 800 and Series 600A.



NATIONAL CRANE

General Offices: 11200 North 148th Street/Waverly, NE 68462/402/786-2240
Telex: 438061

Your National Dealer

National reserves the right to change designs, prices, and specifications at any time without notice.