



**HYDRAULIC  
CRANES**



**GROVE<sup>®</sup>  
TMS250A**

**HYDRAULIC  
CRANE with  
TRAPEZOIDAL<sup>†</sup>  
BOOM** **25** TON  
CAPACITY

<sup>†</sup> Patented Grove feature





# SUPERSTRUCTURE SPECIFICATIONS

**BOOM**— 32 ft.-106 ft. total length (9.8m-32.3m); 3 section trapezoidal main boom consistency of base section and 2 full power sections with positive cable synchronization to 80 ft. (24.4m) plus a 26 ft. (7.9m) "Swingaway" lattice extension (2° offset) to 106 ft. (32.3m). Mid section is powered by one 7 in. (178mm) bore diameter cylinder with integral holding valve. Fly section is extended by a 1-1/8 in. (29mm) diameter extension cable with 24-3/4 in. (629mm) tread diameter boom extension sheaves and retracted by a separate 5/8 in. (16mm) cable. Boom telescope sections are supported on graphite impregnated nylatron wear pads. Side adjustable wear pads prevent metal to metal contact of inner boom sections and permit ease of boom side alignment.

\***JIB** — 22 ft. (6.7m) "A"-frame section attaches to sheave shaft of the 26 ft. (7.9m) triangular lattice "swingaway" boom extension. Jib stows beneath extension alongside base boom section or can be detached from "Swingaway" and held firmly in place on base section when extension is used independently. Jib can be offset from a minimum of 5° to a maximum of 30° and includes jib backstops, single rope self-equalizing suspension and removable pin type rope guard. NOTE - cannot be used with "telescopic swingaway" described below.

\***BOOM EXTENSION** — 26 ft.-46 ft. (7.9m-14m) telescopic "Swingaway." 20 ft. (6.1m) rectangular roller mounted extension is manually extended and retracted from within 26 ft. (7.9m) lattice "Swingaway." (2° offset).

**BOOM NOSE** — Four sheaves, 13-3/4 in. (349mm) tread diameter, mounted on heavy duty tapered roller bearings (NOTE - Three sheaves used when Grove Model 25H-16 main hoist specified). Removable pin type rope guards permit easy reeving. Rope dead ends provided on each side of main boom base. NOTE - Cannot be used with 22 ft. "A"-frame described above.

\***BOOM NOSE** — Single 13-3/4 in. (349mm) tread diameter sheave auxiliary boom nose mounted to main boom nose with removable pin type rope guard for single part line work.

**BOOM ELEVATION** — Single, 10 in. (254mm) bore, double-acting, hydraulic cylinder with integral holding valves; elevation from -4° to 75°. Combination controls provided for hand or foot operation.

\* **LOAD MOMENT AND ANTI-TWO BLOCK SYSTEM (KRUGER)** — Audio-visual warning in combination with Grove control lever lockout of: hoist up, telescope out and boom down functions.

**CAB** — Full vision, all steel, fully enclosed, acoustically treated with tinted tempered safety glass throughout (removable front windshield with storage provision and hinged skylight are tinted laminated safety glass). Sliding left side door and sliding right

side window for ventilation. Adjustable full length control levers, combination hand and foot controls for swing and boom elevation. Fully adjustable operators seat with headrest. Complete engine instrumentation and controls. Combination hand and foot throttle. All-crane superstructure and outrigger controls, sight leveling bubble, electronic boom angle indicator, 20,000 BTU diesel fuel heater, electric windshield wiper, defroster fan and swing horn; door and window locks, domelight, dashlight, 3-3/4 lbs. (1.7kg) dry type fire extinguisher.

**CAB INSTRUMENTATION** — Engine oil pressure and water temperature gauges, voltmeter, tachometer, fuel level gauge, ignition-on indicator light.

**SWING** — Ball bearing swing circle, 360° continuous rotation. Grove planetary "glide swing" with foot actuated disc swing brake, hand operated turntable brake and 360° positive swing lock. Combination controls provided for hand or foot operation. Swing speed 2.7 RPM.

**OUTRIGGER CONTROLS** — Independently controlled in-out-up-and-down from superstructure cab. Sequence control arrangement virtually eliminates accidental outrigger actuation.

**COUNTERWEIGHT** — Stationary mounted on turntable.

## HYDRAULIC SYSTEM:

**RESERVOIR** — 86 gallons (326 liters) capacity, all-steel welded construction with integral baffles, clean out access, magnetic drain plug and exterior oil sight level.

**FILTER** — Return line type, full flow with bypass protection and bypass indicator, replaceable cartridge. 25 micron rating.

**PUMPS**— Three section, gear type, PTO drive off transmission with disconnect operated from carrier cab. Combined capacity 112.5 GPM (426 lpm). Pumps are mounted so as to rotate in the same direction regardless of the transmission gear selection (forward or reverse); therefore, eliminating any possibility of pump cavitation resulting from operation in reverse gear.

**CONTROL VALVES** — Precision four-way, double-acting with integral load check, main and circuit relief valves. Three individual valve banks permit simultaneous independent control of three crane functions. Maximum operating pressure 2500 PSI (176kg/cm<sup>2</sup>).

**POWER DISTRIBUTION** — (Swing, outriggers — 26.5 GPM [100 lpm]) (Main hoist — 39.5 GPM [150 lpm]) (Boom elevation, telescope, auxiliary hoist, main hoist boost — 46.5 GPM [176 lpm]).

\* Denotes optional equipment.

ITEM	POUNDS			KILOGRAMS		
	GROSS	FRONT	REAR	GROSS	FRONT	REAR
Basic standard machine to include 32 ft.-80 ft. (9.8m-24.4m) trapezoidal boom, 26 ft. (7.9m) swingaway extension, Grove 15H-16B main hoist, 450 ft. (137.2m) of 5/8 in. (16mm) rope.						
• 3,800 lb. (1724kg) counterweight, Grove 6x4 carrier, Cummins V8-210 engine.	48,728	15,423	33,305	22 103	6996	15 107
ADD:						
25 ton (25MT), hookblock (travel position).	+561	+730	-169	+254	+331	-77
7-1/2 ton (6.8MT) headache ball.	+300	+320	-20	+136	+145	-9
5 ton (4.5MT) headache ball.	+150	+160	-10	+68	+73	-5
Auxiliary boom head.	+106	+176	-70	+48	+80	-32
Kruger Load Moment and Anti-Two Block System	+376	+96	+280	+171	+44	+127
• Grove 15S-16B auxiliary hoist with 350' (106.7m) of 5/8" (16mm) rope.	+972	-441	+1,413	+440	-200	+640
• Gearmatic 11 SGEGR auxiliary hoist with 350' (106.7m) of 1/2" (13mm) rope.	+992	-450	+1,442	+450	-204	+654
SUBSTITUTE:						
22 ft. (6.7m) "A"-Frame Jib.	+1,000	+632	+368	+454	+287	+167
26 ft.-46 ft. (7.9m-14m) telescopic extension.	+695	+534	+161	+315	+242	+73
• Grove 25H-16 main hoist with 400' (121.9m) of 5/8" (16mm) rope.	+1,044	-571	+1,615	+474	-259	+733
Caterpillar 3208 engine.	-48	-43	-5	-22	-20	-2
GM 6V-53N engine.	+80	+72	+8	+36	+32	+4
• 2,600 lb. (1179kg) Superstructure Counterweight.	-1,200	+605	-1805	-544	+274	-818
• 1,600 lb. (726kg) Superstructure Counterweight.	-2,200	+1108	-3308	-998	+503	-1501
REMOVE:						
26 ft. (7.9m) swingaway extension.	-1,071	-846	-225	-486	-384	-102
Front Burnper Counterweight	-1,750	-2,170	+420	-794	-984	+190
• Standard Superstructure Cwg't (15H-16B Main Hoist Only).	-3,800	+1,913	-5,713	-1724	+868	-2592

• NOTE: Appropriate superstructure counterweight substitutions must be made depending on hoist configurations selected:  
 15H-16B Main Hoist, no auxiliary hoist — 3,800 lb. (1724kg) Cwg't.  
 25H-16 Main Hoist, no auxiliary hoist — 2,600 lb. (1179kg) Cwg't.  
 15H-16B Main and 15S-16B or 11 SGEGR auxiliary hoist — 2,600 lb. (1179kg) Cwg't.  
 25H-16 Main and 15S-16B or 11 SGEGR auxiliary hoist — 1,600 lb. (726kg) Cwg't.



**3,250 lbs. @ 129'** TIP HEIGHT  
(1475kg) (39.3m)

**10,000 lbs. @ 109'** TIP HEIGHT  
(4535kg) (33.2m)

**20,000 lbs. @ 83'** TIP HEIGHT  
(9070kg) (25.3m)

**40,500 lbs. @ 59'** TIP HEIGHT  
(18 370kg) (18m)

**THE NEW**

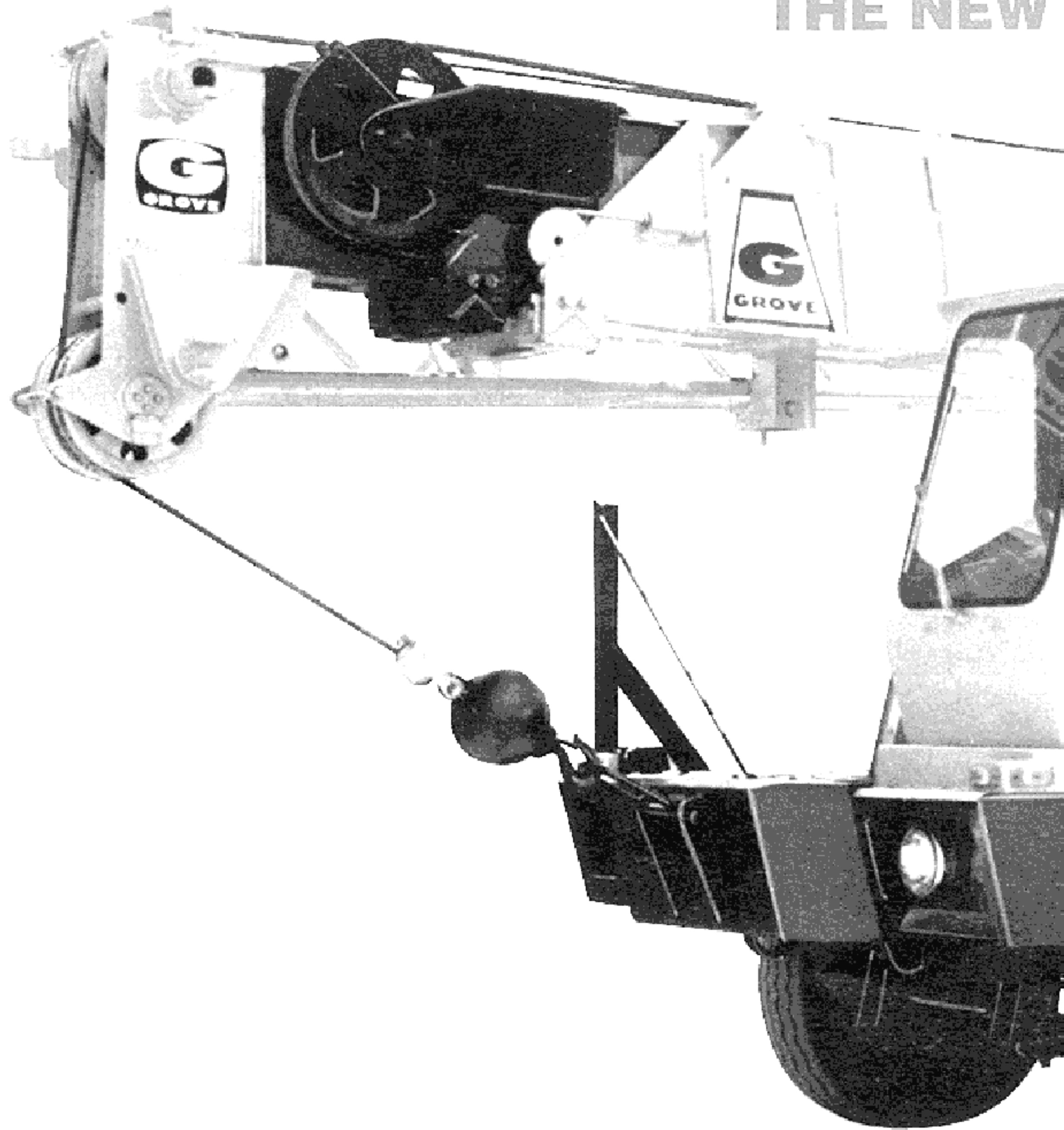

**GROVE HOISTS** . . . Both main and auxiliary hoists are of Grove design and manufacture except for the optional controlled free fall hoist. They are planetary gear drive, power up and down, equal speed with integral automatic brake. Hoisting and lowering speeds can be controlled from zero to maximum under all load conditions. The optional main hoist, model 25H-16, is a high speed hoist providing 470 FPM line speed with a line pull of 9,610 lbs. (4359kg).

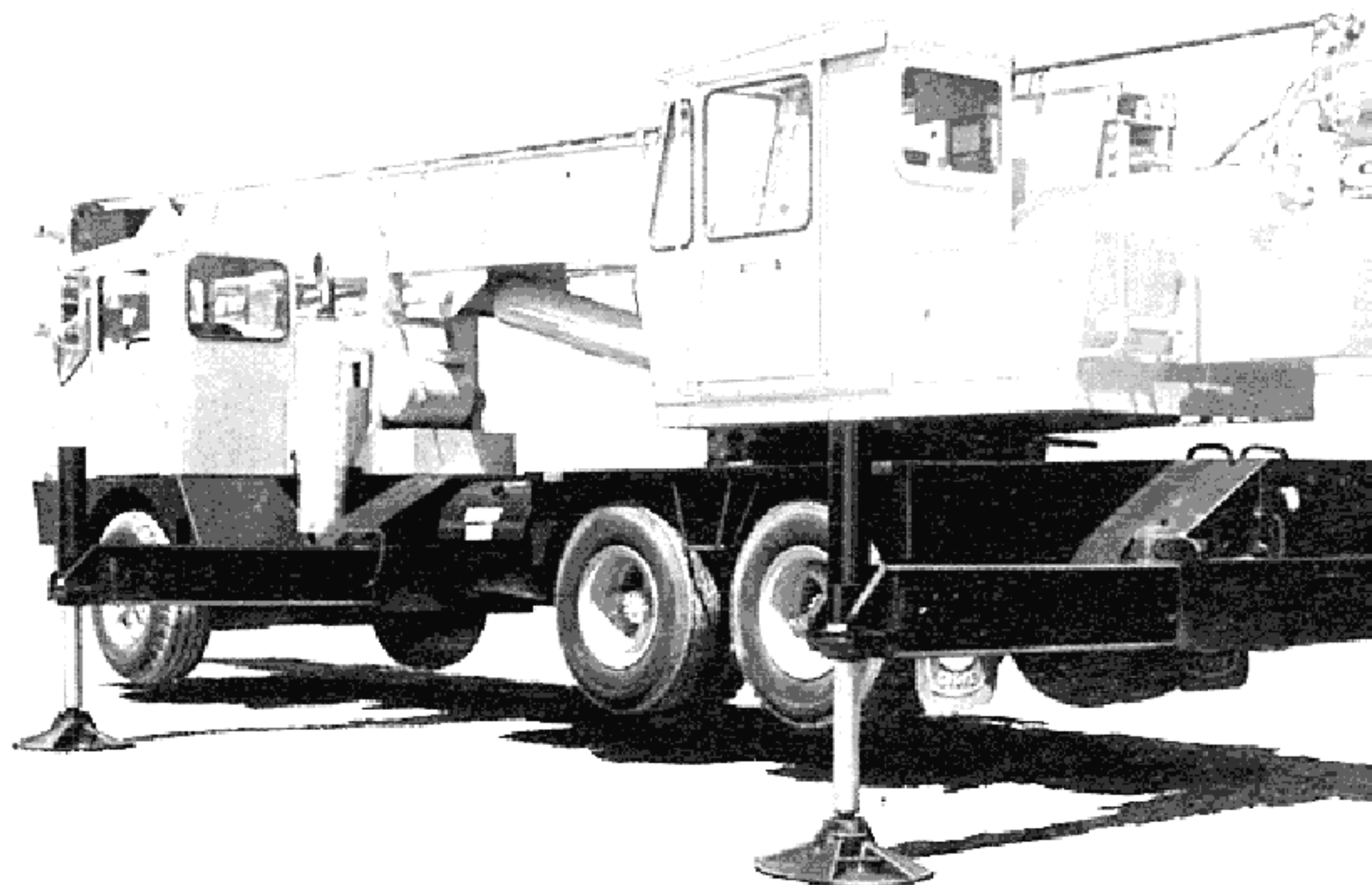



# TMS250A TRAPEZOIDAL<sup>†</sup> BOOM

The 80 ft. (24.4m) Trapezoidal Boom is full power incorporating a hydraulic cylinder plus a positive double cable/sheave arrangement. A single telescope cylinder powers both the mid and fly sections. The hydraulic/mechanical extension procedure insures positive synchronization for extension retraction of the telescoping sections.

<sup>†</sup> Patented Grove feature

**STRONG, LIGHT,  
POSITIVELY  
SYNCHRONIZED . . .  
EXTREMELY  
FAST.**

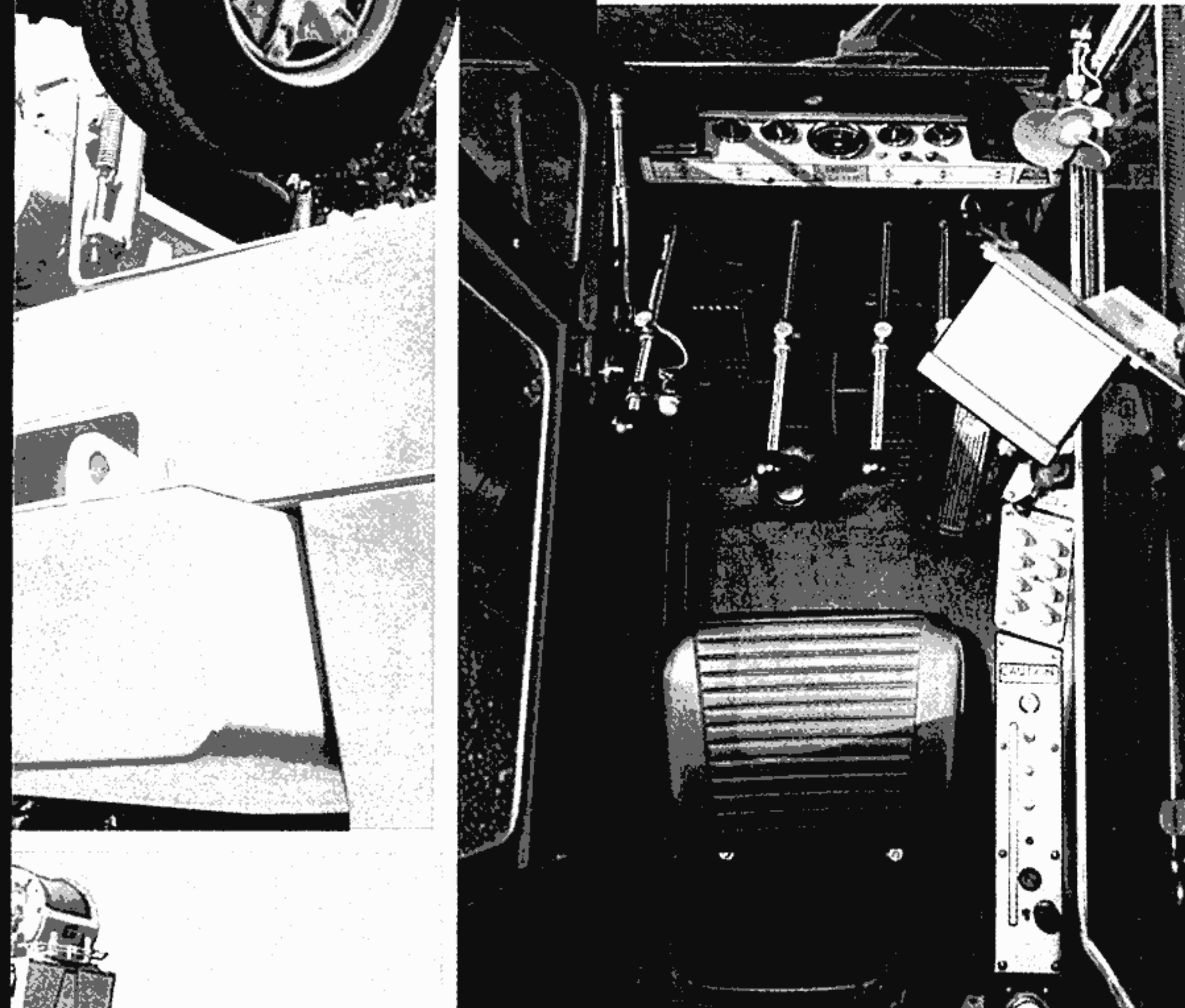
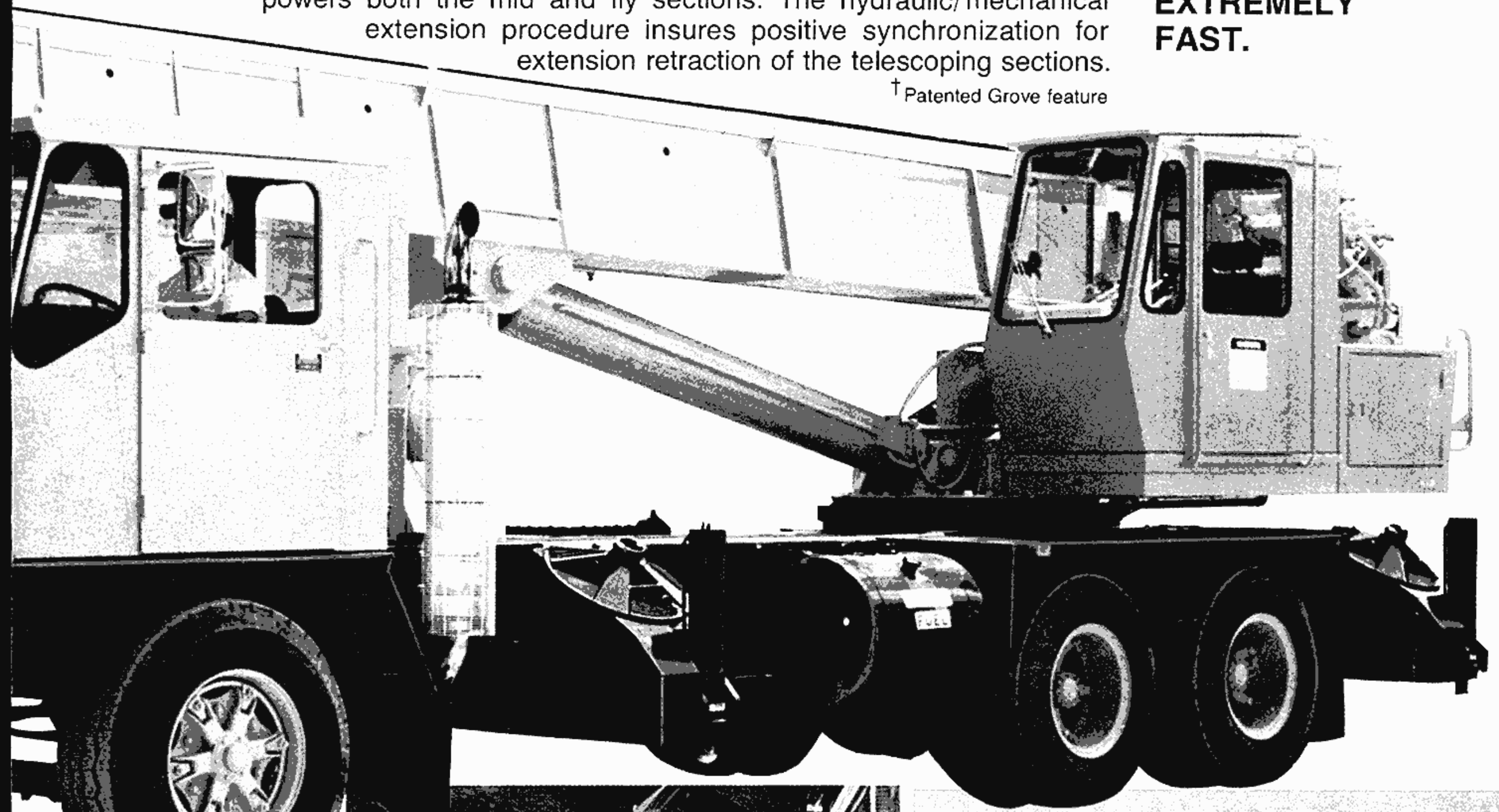

## **DESIGNED FOR OPERATOR-EFFICIENCY**

. . . The interior of the all-steel cab is designed for operator convenience and efficiency. Full length control levers are adjustable and combination hand and foot controls are provided for swing, boom elevation and throttle. Full engine controls and instruments are provided. Other features include a sliding door, tinted safety glass windows, removable windshield and hinged skylight, acoustical treatment and electronic boom angle indicator.

**18 FOOT OUTRIGGER SPREAD** . . . Double-box beam outriggers, integral with the frame, provide an 18 ft. (5.5m) spread for maximum stability. Beams and jacks are independently controlled from the superstructure cab. Stowable, 24 in. (610mm) dia. steel outrigger pads assure excellent ground contact.



# SUPERSTRUCTURE SPECIFICATIONS



## HOIST SPECIFICATIONS

DESCRIPTION: Power up and down, equal speed, planetary reduction with integral automatic brake. Electronic hoist drum rotation indicator.				
HOIST DATA	MAIN HOIST Grove Model 15H-16B	*MAIN HOIST Grove Model 25H-16	*AUXILIARY HOIST Grove Model 15S-16B	*AUXILIARY HOIST Gearmatic Model 11 SGEGR (Controlled Free Fall)
Drum Dimensions	12 in. dia. (305mm) 16 in. length (406mm) 17.5 in. flange dia. (445mm)	16 in. dia. (406mm) 16 in. length (406mm) 24 in. flange dia. (610mm)	12 in. dia. (305mm) 16 in. length (406mm) 17.5 in. flange dia. (445mm)	9 in. dia. (229mm) 13 in. length (330mm) 17.5 in. flange dia. (445mm)
PERFORMANCE: Max. Single Line Speed Max. Single Line Pull	379 FPM (115.5m/min) 9,165 lbs. (4157kg)	470 FPM (143.3m/min) 9,610 lbs. (4359kg)	204 FPM (62.2m/min) 9,165 lbs. (4157kg)	290 FPM (88.4m/min) 9,145 lbs. (4148kg)
Drum Rope Storage Capacity	**480 ft. of 5/8 in. dia. rope (146.3m of 16mm)	**740 ft. of 5/8 in. dia. rope (225.6m of 16mm)	**480 ft. of 5/8 in. dia. rope (146.3m of 16mm)	**675 ft. of 1/2 in. dia. rope (205.7m of 13mm)
Permissible Single Line Rope Pull	5/8 in. (16mm) 19x7 Class - 7,926 lbs. (3595kg) 5/8 in. (16mm) 6x41 Class - 7,926 lbs. (3595kg)	5/8 in. (16mm) 19x7 Class - 8,418 lbs. (3818kg) 5/8 in. (16mm) 6x41 Class - 8,418 lbs. (3818kg)	5/8 in. (16mm) 19x7 Class - 7,926 lbs. (3595kg) 5/8 in. (16mm) 6x41 Class - 7,926 lbs. (3595kg)	1/2 in. (13mm) 19x7 Class - 6,150 lbs. (2790kg) 1/2 in. (13mm) 6x37 Class - 7,200 lbs. (3266kg)

\* 5th layer of rope not recommended for hoisting operations. (6th layer for Model 25H-16 main hoist)  
\* Denotes optional equipment. Auxiliary hoist control valve arrangement is standard equipment.

## CARRIER SPECIFICATIONS

### GROVE CARRIER 6X4

**OUTRIGGERS** — Hydraulic, double-box telescoping beam outriggers front and rear 5-1/2 in. (140mm) bore diameter. Vertical jack cylinders are equipped with integral holding valves and 24 in. (610mm) dia. lightweight steel floats. Beams extend to 18 ft. (5.5m) centerline to centerline, retract to 8 ft. (2.4m) overall width by 3 in. (76mm) bore diameter extension cylinders. Complete controls and sight leveling indicator located in superstructure cab.

**FRAME** — High-strength steel, all-welded construction with box type design and integral welded outrigger boxes.

**STEERING** — Sheppard rack and pinion design with power assist.

**CLUTCH** — Lipe Rollway 14 in. (356mm), single plate dry disc. Lining area: 218 sq. in. (1407cm<sup>2</sup>).

**TRANSMISSION** — Fuller Roadranger RTO 613, 13 speeds forward and 3 reverse. Single lever shift control with 3 position air shift range selector; neutral safety start.

**UNIVERSAL JOINTS** — Needle bearing type.

**AXLES** — Front: Single non-driving I-beam, Rockwell FL-931, 18,000 lbs. (8165kg) capacity. Rear: Rockwell SLHD single reduction tandem, 34,000 lbs. (15 422kg) capacity with inter-axle differential and dash-mounted control.

**SUSPENSION** — Front: Reyco spring mounted with shock absorbers. Rear: Hendrickson solid mounted tandem.

**FUEL TANK** — Single 60 gallons (227 liters) capacity mounted on left side of frame.

**TIRES** — Front: (2) 15x22.5-16 ply rated duplex hi-way tread, tubeless (12:00x20 radial or 16.5x22.5 tires—optional). Rear: (8) 9:00x20-10 ply rated hi-way tread, tube type (9:00x20 radial, 10:00x20, 15:00x22.5 or 16.5x22.5 duplex singles—optional).

### SPEED AND GRADEABILITY

Engine	Speed Ranges	% of Gradeability (@ Max. Torque)
Cummins V8-210	3.59 to 65.11 MPH (5.8 to 104.8km/h)	35.38 to .53%
*GM6V-53N	3.35 to 60.81 MPH (5.5 to 98km/h)	40.69 to .33%
*Caterpillar 3208	3.35 to 60.81 MPH (5.4 to 98km/h)	41.16 to .35%

NOTE: Performance based on 48,000 lbs. (21 773-kg) GVW and standard SAE engine rating conditions using standard tires, transmissions and axles. Performance data may vary plus or minus 10% due to variations in engine performance and vehicle weights. Maximum vehicle speed restricted to 50 mph (80.5km/h) with standard 900 x 20-10 ply rated dual rear tires, 60 mph (96.5km/h) with optional rear tires.

**WHEELS** — Front: Steel spoke, 12.25 in.x22.5 in. rims (311mmx 572mm). Rear: Steel spoke, 7 in.x20 in. rims (178mmx 508mm).

**BRAKES** — Full air on all wheels with air dryer. Total lining area: 1256 sq. in. (8104cm<sup>2</sup>).

Front: 15 in.x6 in. (381mmx152mm). Rear: 15 in.x7 in. (381mmx178mm) "Complies with FMVSS121 (Air Brake Systems)".

**PARKING BRAKE** — Spring set emergency chambers on both rear axles with dash mounted release kit.

**ELECTRICAL SYSTEM** — 24-volt starting, 12-volt lighting. U.S. federal safety standard lights and reflectors.

**CAB** — One man, all-steel with acoustical treatment; tinted tempered safety glass (windshield is tinted laminated), electric windshield washer, wiper and defroster fan, door and window locks. Bostrom T-bar seat with belt, dual rear view mirrors, dome light, dashlight, hot water heater, electric horn, traffic hazard warning switch (four-way flasher) complete engine instrumentation and carrier driving controls, 3-3/4 lbs. (1.7kg) dry type fire extinguisher.

**CAB INSTRUMENTATION** — Electric tachometer, engine oil pressure and water temperature gauges, voltmeter, speedometer, air pressure gauge, electric fuel gauge, high beam indicator, low air pressure audio-visual warning, ignition-on indicator, pump engaged indicator.

**MISCELLANEOUS STANDARD EQUIPMENT** — Wheel nut wrench and handle, channel front bumper, two front towing loops, front and rear fenders, ether injection starting aid (less canister), mud flaps, sling box, boom rest, hookblock tie down.

### ENGINE SPECIFICATIONS

MAKE & MODEL TYPE	Cummins V8-210 8 Cylinder O.H.V.	*GM6V-53N 6 Cylinder O.H.V.	*Caterpillar 3208 8 Cylinder O.H.V.
BORE & STROKE	4.625 in. x 3.75 in. (117mm x 95mm)	3.875 in. x 4.5 in. (98mm x 114mm)	4.5 in. x 5.0 in. (114mm x 127mm)
DISPLACEMENT	504 cu. in. (8259cm <sup>3</sup> )	318 cu. in. (5212cm <sup>3</sup> )	636 cu. in. (10 424cm <sup>3</sup> )
HORSEPOWER (NET)	160 @ 2800 RPM	176 @ 2600 RPM	160 @ 2600 RPM
GOVERNED RPM	2800 RPM	2600 RPM	2600 RPM
TORQUE (NET)	343 lbs. ft. @ 1900 RPM (47kg.m)	397 lbs. ft. @ 1800 RPM (55kg.m)	413 lbs. ft. @ 1200 RPM (57kg.m)
ELECTRICAL SYSTEM	12 volt neg. ground	12 volt neg. ground	12 volt neg. ground
COMBUSTION SYSTEM	4 cycle, naturally aspirated	2 cycle, with blower	4 cycle, naturally aspirated
COOLING SYSTEM	Liquid	Liquid	Liquid
FUEL CAPACITY	60 gals. (227 liters)	60 gals. (227 liters)	60 gals. (227 liters)
ALTERNATOR	90 Amp 12 Volt	90 Amp 12 Volt	90 Amp 12 Volt
BATTERY	(4) 12v., 1900 cold cranking Amps @ 0°F	(4) 12v., 1900 cold cranking Amps @ 0°F	(4) 12v., 1900 cold cranking Amps @ 0°F
AIR CLEANER	Dry type	Dry type	Dry type
AIR COMPRESSOR	13.5 CFM (383 L/Min)	12 CFM (340 L/min)	12 CFM (340 L/min)
HOURLY METER	Std.	Std.	Std.
STARTING SYSTEM	24 Volt	24 Volt	24 Volt

NOTE: Jacobs engine brake (GM and Cummins) is optional.

\*Denotes optional equipment.



# DIMENSIONS

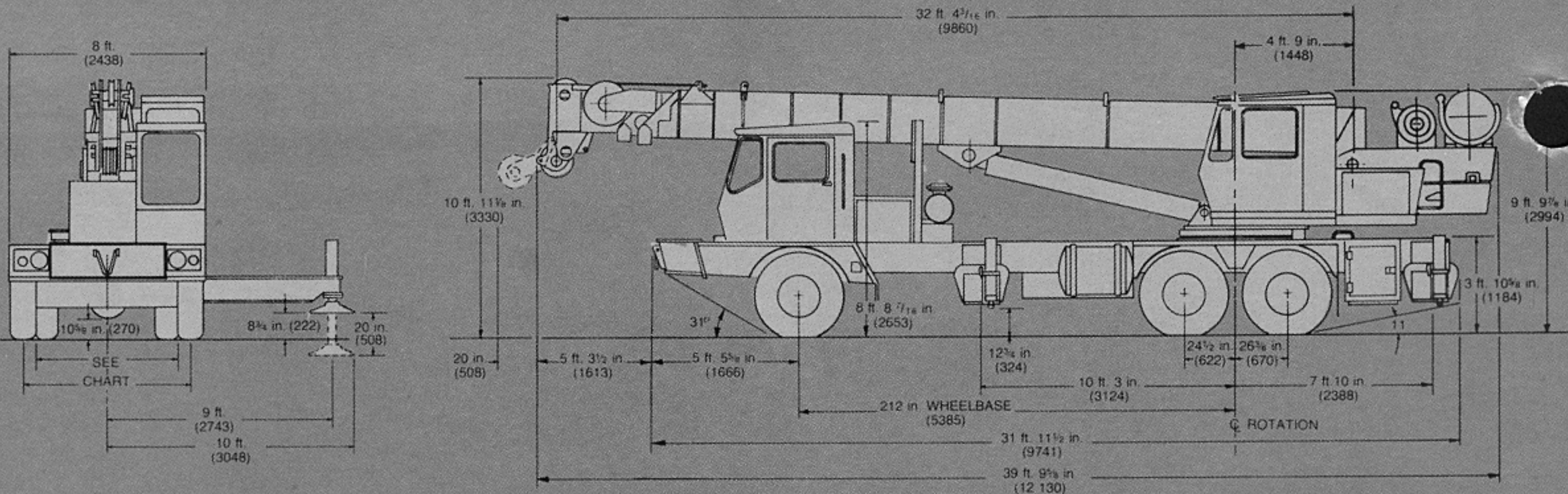

TAIL SWING – 11 ft. 5-7/16 in. (3491)

FRONT TIRE SIZE	FRONT TRACK	TURNING RADIUS	REAR TIRE SIZE	REAR TRACK
15:00 x 22.5	81 7/8" (2080)	38' (11 582)	9:00 x 20	72" (1829)
*16.5 x 22.5	81 7/8" (2080)	38' (11 582)	*15.5 x 22.5	72 3/4" (1848)
*12:00 x 20	78 5/8" (1997)	38' (11 582)	*16.5 x 22.5	72 3/4" (1848)

Constant improvement and engineering progress makes it necessary that we reserve the right to make specification, equipment, and price changes without notice. Illustrations shown may include optional equipment and accessories and may not include all standard equipment. Meets requirements of P.C.S.A. Standard No. 2.  
*NOTE: Dimensions in parenthesis are millimeters (mm).*

**T**HE TMS250A is a smooth performer with the precise handling and built-in reliability for which Grove Cranes are internationally known. It is the combined product of an outstanding research and design group and produced by a manufacturing team second to none. From the wheels up it is designed and built by Grove to give you the high availability and lasting quality you expect from the industry leader. And, no matter where your TMS250A is working, you know there is a reliable Grove distributor nearby ready to give service when needed.

## THE MOST COMPLETE LINE OF HYDRAULIC CRANES

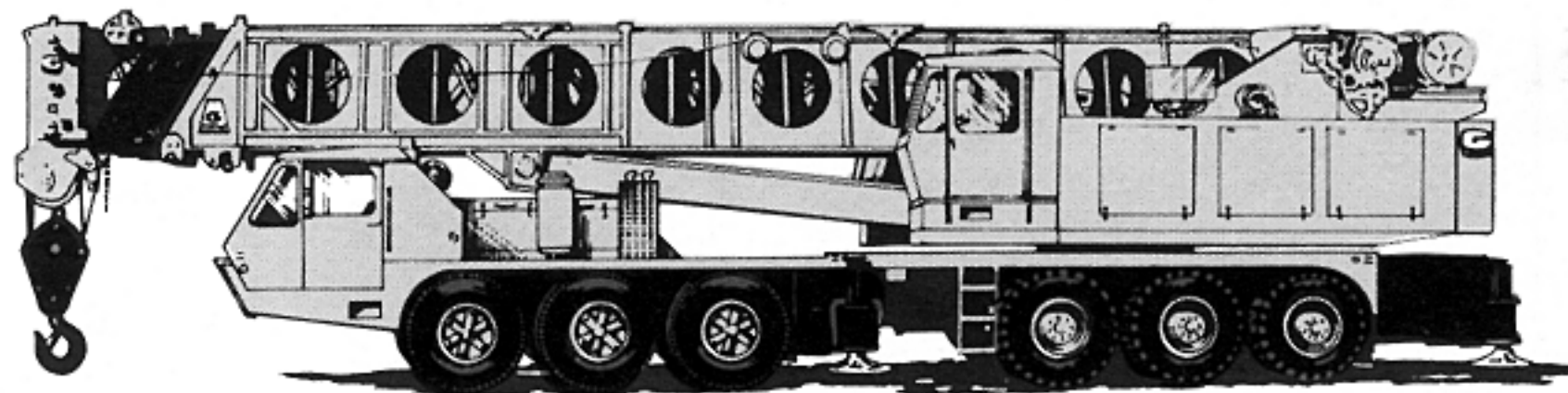

**CARRIER MOUNTED CRANES** 15 through 140 tons  
(18 through 130 tons metric)

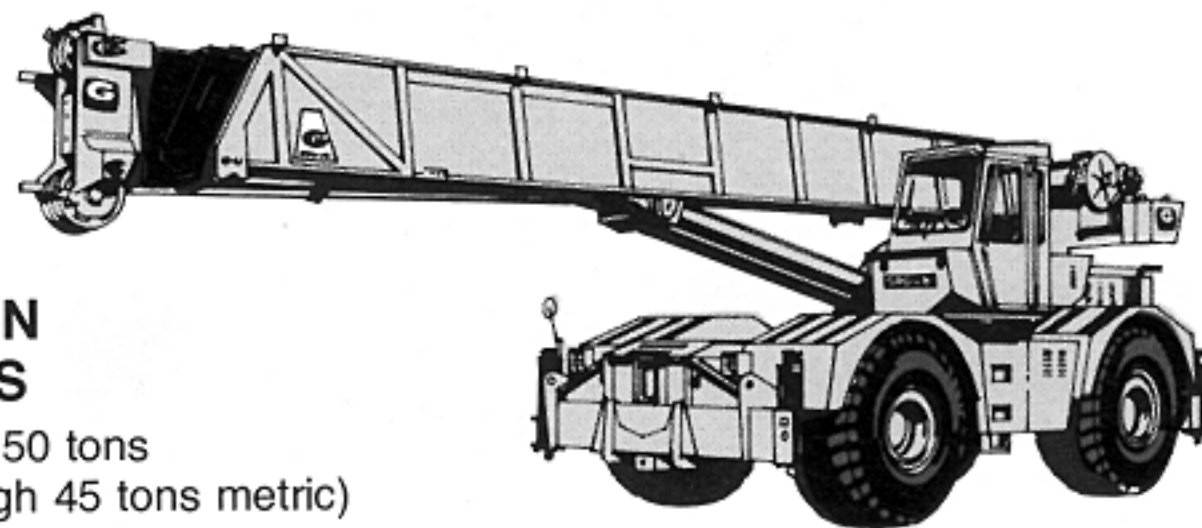

**ROUGH TERRAIN CRANES**  
8 through 50 tons  
(7.3 through 45 tons metric)



**WORLD LEADER IN HYDRAULIC CRANES**

**GROVE**  
Division of Walter Kidde & Company, Inc.  
**KIDDE**