

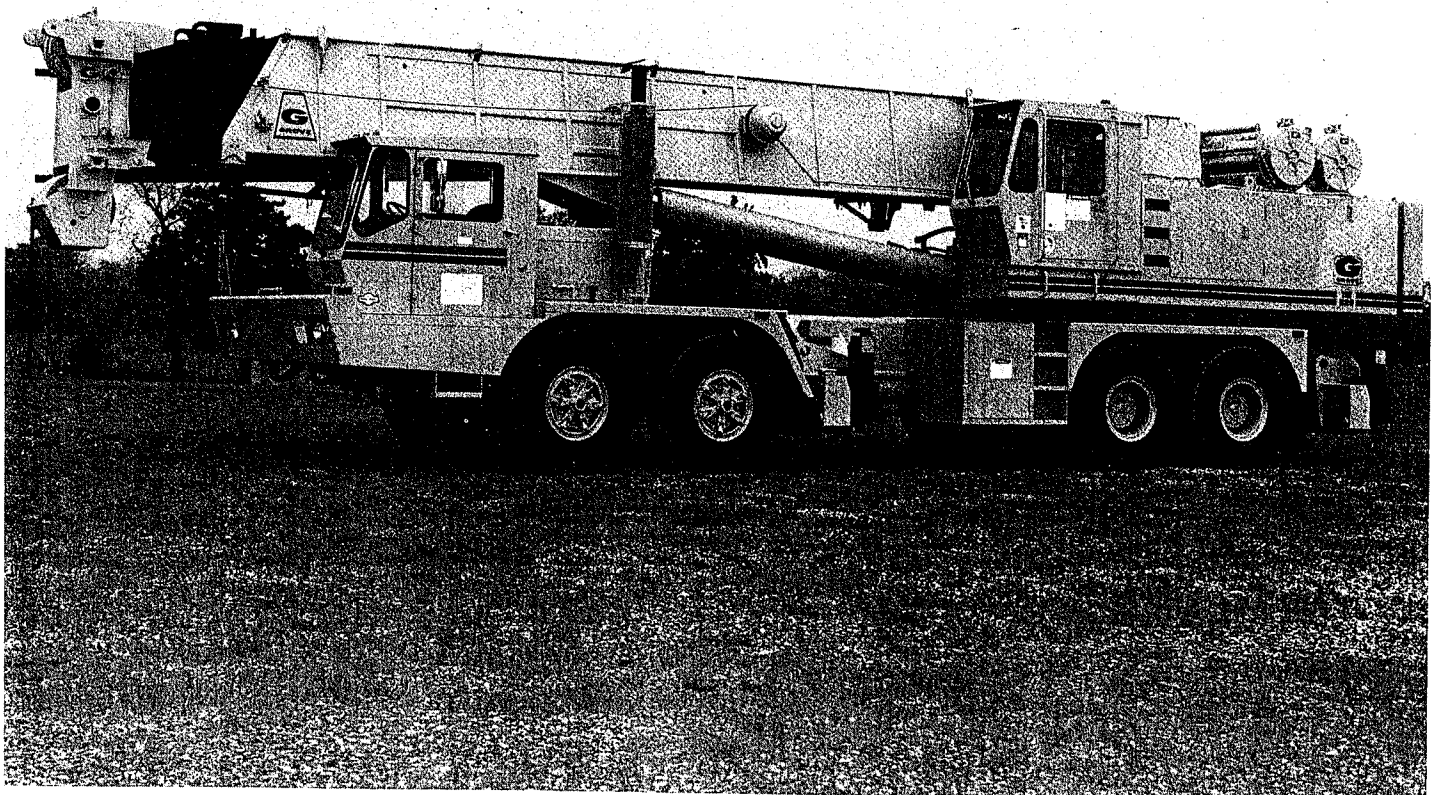

# TM880

Truck-mounted hydraulic crane

- Capacity 80 tons (72,500 kg)
- Maximum on-board boom and jib length 172 ft. (52.4m)
- Maximum tip height 207 ft. (63.1m)
- Optional 33 ft.-58 ft. (10m-17.7m) Telescopic Swingaway offsets to 30°.



# Superstructure specifications

<b>Boom</b>	36 ft. to 114 ft. (11m - 34.8m) four section Trapezoidal† full power boom. Each boom section has individually controlled telescope sections supported on graphite impregnated nylon wear pads. Maximum Tip Height: 122 ft. (37.1m).
<b>Swingaway Extension</b>	33 ft. (10.0m) lattice swingaway boom extension stows alongside base boom section when not in use. Offsettable at 2°, 15° or 30°. Maximum Tip Height: 155 ft. (47.2m).
<b>Optional* Telescopic Swingaway Extension</b>	33 ft. to 58 ft. (10.0 to 17.7m) telescopic lattice swingaway extension with offset links, offsettable at 2°, 15° or 30°. Stows alongside base boom when not in use. Maximum Tip Height - 179 ft. (54.5m).
<b>Optional Jib Extension</b>	46 ft. (14m), 60 ft. (18.3m), 74 ft. (22.5m) and 88 ft. (26.8m) fixed offset jib. Maximum Tip Height: 208 ft. (63.4m).
<b>Boom Nose</b>	Six sheaves mounted on heavy duty tapered roller bearings with removable pin-type rope guards. *Optional removable auxiliary boom nose with removable pin type rope guard.
<b>Boom Elevation</b>	Two double acting hydraulic cylinders with integral holding valve provides elevation for -4° to 80°.
<b>Anti-Two Block Device</b>	Audio-visual (light/buzzer) warning system and Grove control lever lockout system with electronic boom angle and length indication.
<b>Optional* LMI</b>	Audio-visual (light/buzzer) warning system and Grove control lever lockout system with electronic boom angle, length, radius and relative load moment indication.
<b>Cab</b>	Full vision, all steel fabricated with acoustical lining and tinted safety glass throughout. Dash panel incorporates gauges for all engine functions. Other standard features include: hinged skylight, sliding left side door and sliding right side window, electric windshield wash-wipe, circulating air fan, heater, swing horn, fire extinguisher, seat belt. *Optional items: electric skylight wiper and air conditioning.
<b>Swing</b>	Roller bearing swing circle with 360° continuous rotation. Grove planetary "glide-swing" with foot actuated disc brake, spring applied hydraulically released park brake and 360° position positive turntable lock. Combination controls provided for hand or foot operation. Swing speed 1.8 RPM.

<b>Counterweight</b>	Fixed position pinned to turntable.
<b>Engine</b>	Detroit diesel 6-71N naturally aspirated six cylinder water cooled 426 cu. in. 210 bhp (157 kw) (gross) @ 2100 RPM. Maximum torque 584 ft. lbs. @ 1500 RPM.
<b>HYDRAULIC SYSTEM</b>	
<b>Pumps</b>	Five main gear pumps by superstructure engine. Manual pump disconnect. Combined capacity 289 G.P.M. (1094 LPM).
<b>Valves</b>	Precision four way double acting control valves, 5 individual valve banks permit simultaneous control of multiple crane functions.
<b>Filter</b>	Suction line type, full flow with bypass protection and filter bypass indicator, replaceable cartridge, 25 micron rating.
<b>Reservoir</b>	305 gallons (1154 liters) with spin-on breather filter, external sight gauge, clean out access, strap mounted to frame.
<b>Oil Cooler</b>	Full flow, fin and tube, oil to air.

## HOIST SPECIFICATIONS

Series parallel circuitry and two motors provide both high line pull and speed ranges. Power up and down, equal speed, planetary reduction with integral automatic brake and electronic hoist drum rotation indicator.

### Main Hoist - H030B-26 or \*Auxiliary Hoist - H030B-16

		HIGH RANGE	LOW RANGE
<b>Maximum single line speed</b>	Bottom layer	415 FPM (126.5m/min)	210 FPM (64m/min)
	Intermediate layer	505 FPM (154m/min)	255 FPM (77.7m/min)
	Top layer	575 FPM (175.3m/min)	290 FPM (88.4m/min)
<b>Maximum single line pull</b>	Bottom layer	8,400 lbs. (3810 kg)	16,800 lbs. (7620 kg)
	Intermediate layer	6,945 lbs. (3150 kg)	13,890 lbs. (6301 kg)
	Top layer	6,125 lbs. (2778 kg)	12,245 lbs. (5554 kg)
<b>Maximum usable rope stowage</b>	Main	640 ft. of 3/4 dia. rope (323m of 19mm)	Aux. 390 ft. of 3/4 dia. rope (198m of 19mm)
	<b>Maximum permissible line pull w/3.5:1</b>		
		3/4 in. (19mm) Dyform 18 14,605 lbs. (6625 kg)	

†Patented Grove feature or patent pending.  
\*Denotes optional equipment.

# Carrier specifications

<b>Frame</b>	High strength alloy steel all welded box-type construction with integral outrigger housings and front/rear lifting, towing and tie down lugs.
<b>Outrigger System</b>	Hydraulic double stage double box telescopic beam and jack outriggers with integral holding valves. All steel fabricated quick release type outrigger floats. 30 1/2" (775mm) diameter.
<b>Outrigger Controls</b>	Located in the superstructure cab and on both sides of the carrier frame. Push button controls requiring two-handed operation for safety. Crane level indicator (sight bubble) adjacent to each set of controls.
<b>Engine</b>	GM8V-71N eight cylinder naturally aspirated water cooled diesel, 568 cu. in. (9.3L) 304 bhp (227 kw) (Gross) @ 2,100 RPM. Maximum torque 748 ft. lbs. & 1,400 RPM.
<b>Optional Engine</b>	Cummins NTC350 six cylinder turbo-charged water cooled diesel 855 cu. in. (14.0L) 350 bhp (261 kw) (Gross) & 2,100 RPM. Maximum torque 1,046 ft. lbs. @ 1,300 RPM.
<b>Optional Engine</b>	Cummins NTCC350 (California).
<b>Fuel Tank Capacity</b>	(1) 100 gallons (379 liters).
<b>Electrical System</b>	Two 12 volt - maintenance free batteries, 24 volt starting.
<b>Drive</b>	8 x 4.
<b>Steering</b>	Front axle steering, cam and lever type with hydraulic assist.
<b>Transmission</b>	Synchromesh gearbox with 13 speeds forward and 2 reverse.
<b>Axles</b>	Axles 1 & 2 steer and axles 3 & 4 drive. Axles 1 & 2, steering, tubular steel, 100 in. track. Axles 3 & 4, planetary drive, 90 in. track.
<b>Suspension</b>	Front axles (1 & 2) spring mounted tandem. Rear axles (3 & 4) solid mount tandem with equalizing and solid steel saddles.
<b>Tires</b>	14.00R x 20 radial tube-type, highway tread front and rear.
<b>Brakes</b>	Full air on all wheels. Air dryer provided to preclude moisture accumulation. Spring set emergency brake on both rear axles with emergency release.

<b>Lights</b>	Full lighting including head, tail, braking, reversing fog, directional and hazard warning lights.
<b>Maximum Speed</b>	49.0 MPH (78.8 km/hr).
<b>Gross Vehicle Weight &amp; Axle Loads</b>	BASIC STANDARD MACHINE Machine to basic specification. Front 35,941 lbs. (16,303 kgs) Rear 71,749 lbs. (32,545 kgs) G.V.W. 107,690 lbs. (48,847 kgs)
<b>Equipment</b>	Dual rear view mirrors, hookblock tiedown sling, electronic back-up alarm, light package.
<b>Optional Equipment</b>	Immersion engine block heater, engine low oil pressure/high water temperature, audio visual warning. Jacobs engine brake for Cummins or GM engine, back-up alarm, tire inflation kit.

†Patented Grove feature or patent pending.  
\*Denotes optional equipment.

# Dimensions

# TM880

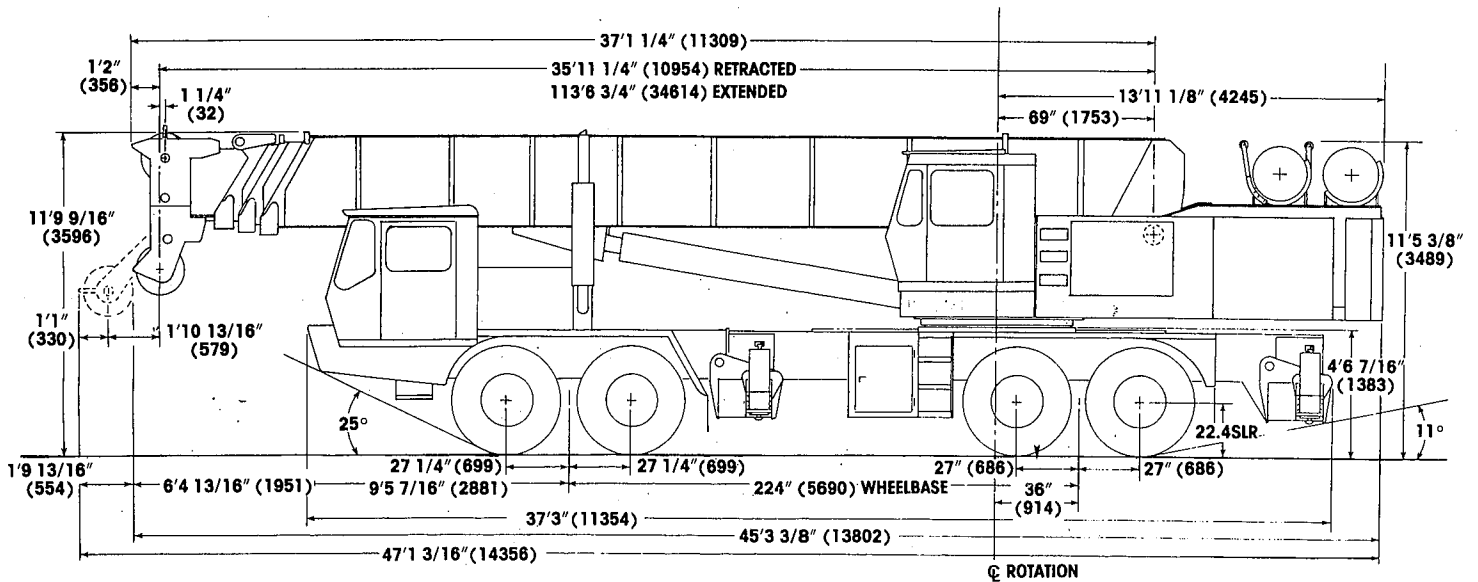
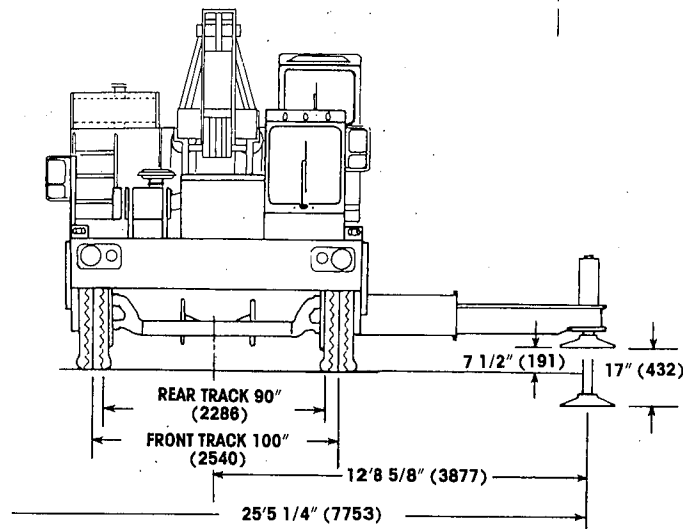
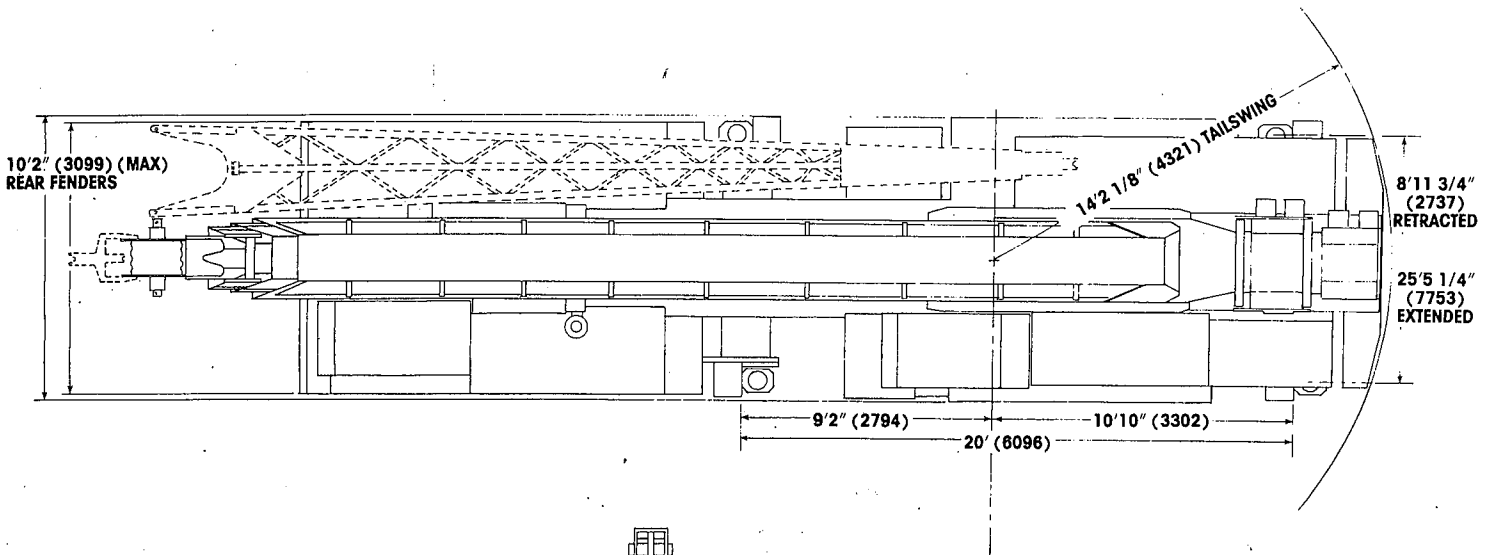

Constant improvement and engineering progress makes it necessary that we reserve the right to make specification, equipment, and price changes without notice. Illustrations shown may include optional equipment and accessories and may not include all standard equipment.

## GROVE MANUFACTURING COMPANY

Division of Kidde, Inc

**KIDDE**

Shady Grove, Pennsylvania 17256-0021

Form No. SBTM880-487-10M Printed in U.S.A.

# NOTES FOR LIFTING CAPACITIES

1. All rated loads have been tested to and meet minimum requirements of SAE J1063 OCT80 - Cantilevered Boom Crane Structures - Method of Test, and do not exceed 85% of the tipping load on outriggers (75% of the tipping load on rubber) as determined by SAE J765 OCT80 Crane Stability Test Code.
2. This chart is intended as a guide only. The individual crane's load chart operating instructions and other instruction plates give details of the conditions under which the crane may be operated safely. ALL OF THESE INSTRUCTIONS MUST BE READ AND UNDERSTOOD PRIOR TO OPERATING THE CRANE.
3. Capacities given do not include the weight of hookblocks, slings, auxiliary lifting equipment and load handling devices. Their weights MUST be added to the load to be lifted. When more than minimum required reeving is used, the additional rope weight shall be considered part of the load.
4. Capacities appearing above the bold line are based on structural strength and tipping should not be relied upon as a capacity limitation.
5. All capacities are for crane on firm, level surface. It may be necessary to have structural supports under the outrigger floats or tires to spread the load to a larger bearing surface.
6. When either boom length or radius or both are between values listed, the smallest load shown at either the next larger radius or boom length shall be used.
7. For outrigger operation, ALL outriggers shall be fully extended with tires raised free of ground before raising the boom or lifting loads.
8. Tires shall be inflated to the recommended pressure before lifting on rubber.
9. Unless otherwise stated, capacities are with powered boom sections equally extended.
10. When a load indicator is fitted certain capacities may be modified to compensate for indicator characteristics.
11. Minimum boom angle with main boom fully extended and 33 ft. (7.6m) or 33-58 ft. (7.6-13.1m) swingaway erected - 39°. Maximum boom length (m) at 0° boom angle with 33 ft. (7.6m) or 33-58 ft. (7.6m-13.1m) swingaway erected - 88 ft. (26.8m).

Constant improvement and engineering progress makes it necessary that we reserve the right to make specification, equipment, and price changes without notice. Illustrations shown may include optional equipment and accessories and may not include all standard equipment.

## GROVE MANUFACTURING COMPANY

Division of Kidde, Inc.

### KIDDE

Shady Grove, Pennsylvania 17256-0021

## 33 FT. FIXED LENGTH EXTENSION (ON OUTRIGGERS - 360°)

Main Boom Angle (Deg.)	2° OFFSET		15° OFFSET		30° OFFSET	
	Rad. Ref. ft.	Cap. lbs.	Rad. Ref. ft.	Cap. lbs.	Rad. Ref. ft.	Cap. lbs.
80	27.0	23,000	32.9	15,650	39.2	11,450
75	39.2	17,200	44.8	12,100	50.6	9,390
70	51.0	14,250	56.2	9,740	61.6	7,900
65	62.5	11,600	67.3	8,060	72.1	6,770
60	73.5	8,700	77.8	6,820	82.0	5,900
55	83.9	5,860	87.7	4,990	91.3	4,250
50	93.7	3,840	96.9	3,260	99.9	2,770
45	102.8	2,360	105.4	1,970	107.7	1,660

For Minimum Boom Angle See Note 11.

A6-829-008492

### WEIGHT REDUCTIONS FOR LOAD HANDLING DEVICES

33 ft. Extension	
*Stowed -	673 lbs.
*Erected -	6,243 lbs.

33 ft. - 58 ft. Tele. Ext.	
*Stowed -	926 lbs.
*Erected (ret.) -	9,322 lbs.
*Erected (ext.) -	12,860 lbs.

\*Reduction of main boom capacities

HOOKBLOCKS:	
15 Ton, 1 Sheave	650 lbs.
80 Ton, 6 Sheave	1,930 lbs.
Auxiliary Boom Head	230 lbs.
10 Ton Headache Ball	560 lbs.
7 1/2 Ton Headache Ball	338 lbs.

## CAPACITIES FOR 33 FT.-58 FT. TELE. OFFSETTABLE EXTENSION (ON OUTRIGGERS - 360°)

Main Boom Angle (Deg.)	33 ft. LENGTH					
	2° OFFSET		15° OFFSET		30° OFFSET	
	Rad. Ref. ft.	Cap. lbs.	Rad. Ref. ft.	Cap. lbs.	Rad. Ref. ft.	Cap. lbs.
80	27.0	22,500	32.9	15,150	39.2	10,950
75	39.2	16,700	44.8	11,600	50.6	8,890
70	51.0	13,750	56.2	9,240	61.6	7,400
65	62.5	11,100	67.3	7,560	72.1	6,270
60	73.5	7,970	77.8	6,320	82.0	5,400
55	83.9	5,120	87.7	4,280	91.3	3,550
50	93.7	3,100	96.9	2,540	99.9	2,060
45	102.8	1,620	105.4	1,240		

For Minimum Boom Angle See Note 11.

**ON OUTRIGGERS FULLY EXTENDED - 360°**

Radius in Feet	Main Boom Length in Feet									
	36	42	51	60	69	78	87	96	105	114
10	160,000 (67)	106,700 (70.5)	101,600 (74)	100,000 (77)	96,700 (79)					
12	123,500 (63)	106,700 (67.5)	101,600 (71.5)	96,500 (75)	87,850 (77)	84,700 (79)				
15	105,000 (57.5)	105,000 (63)	95,300 (68)	84,900 (72)	79,200 (74.5)	77,550 (77)	64,500 (79)			
20	78,850 (47)	78,850 (54.5)	78,850 (61.5)	70,550 (66.5)	64,350 (70)	63,800 (73)	55,000 (75.5)	51,900 (77)	48,450 (78.5)	38,750 (80)
25	60,000 (34)	60,000 (45.5)	60,000 (55)	60,000 (61)	54,000 (65.5)	49,700 (69)	45,600 (72)	43,600 (74)	41,300 (76)	34,000 (77)
30		48,050 (34)	48,050 (47.5)	48,050 (55.5)	46,650 (61)	42,750 (65)	39,150 (68.5)	38,400 (71)	35,350 (73)	30,300 (74.5)
35		38,850 (16.5)	38,850 (39)	38,850 (49.5)	38,850 (56)	37,300 (61)	34,050 (64.5)	32,700 (67.5)	30,700 (70)	27,250 (72)
40	See Warning		31,650 (28.5)	31,650 (42.5)	31,650 (50.5)	31,650 (56.5)	29,950 (61)	28,850 (64.5)	27,000 (67)	24,750 (69)
45	Note 16			25,450 (34.5)	25,450 (45)	25,450 (51.5)	25,450 (57)	25,450 (61)	23,900 (64)	22,650 (66.5)
50				20,800 (24)	20,800 (38.5)	20,800 (46.5)	20,800 (52.5)	20,800 (57.5)	20,800 (61)	20,800 (63.5)
60					14,400 (20)	14,400 (35)	14,400 (43.5)	14,400 (49.5)	14,400 (54)	14,400 (57.5)
70							10,150 (32)	10,150 (40.5)	10,150 (46.5)	10,150 (51)
80							7,150 (12.5)	7,150 (29.5)	7,150 (38)	7,150 (44)
90								4,900 (7)	4,900 (27)	4,900 (35.5)
100										3,080 (24.5)
Minimum boom angle (deg.) for indicated length (no load)										0
Maximum boom length (ft.) at 0 deg. boom angle (no load)										114

OFFSET
Cap. lbs.
11,450
9,390
7,900
6,770
5,900
4,250
2,770
1,660

329-008492

®

**EXTENSION**

Note: Boom angles are in degrees.

A6-829-008789 & -004659B

OFFSET	48 ft. LENGTH						58 ft. LENGTH						Main Boom Angle (Deg.)
	2° OFFSET		15° OFFSET		30° OFFSET		2° OFFSET		15° OFFSET		30° OFFSET		
Cap. lbs.	Rad. Ref. ft.	Cap. lbs.	Rad. Ref. ft.	Cap. lbs.	Rad. Ref. ft.	Cap. lbs.	Rad. Ref. ft.	Cap. lbs.	Rad. Ref. ft.	Cap. lbs.	Rad. Ref. ft.	Cap. lbs.	
10,950	30.2	15,500	39.8	10,000	50.5	7,140	33.1	10,300	47.0	7,780	58.7	5,530	80
8,890	43.7	11,250	52.8	7,840	62.8	5,890	47.5	8,840	60.5	6,130	71.4	4,590	75
7,400	56.8	8,530	65.5	6,300	74.6	4,950	61.5	6,760	73.5	4,960	83.6	3,870	70
6,270	69.6	6,720	77.6	5,190	85.9	4,220	75.1	5,350	86.0	4,100	95.2	3,300	65
5,400	81.8	5,440	89.2	4,350	96.5	3,640	88.1	4,340	97.8	3,440	106.0	2,860	60
3,550	93.4	4,360	100.0	3,220	106.3	2,290	100.5	3,590	108.9	2,510	116.0	1,540	55
2,060	104.2	2,590	110.1	1,790	115.3	1,160	112.1	2,050	119.1	1,160			50
	114.3	1,280											45

A6-829-008410A



# TM880

85% Domestic/36 ft.-114 ft. Full Power Boom

RANGE DIAGRAM  
(UNLADEN BOOM)

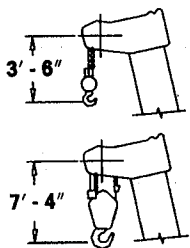
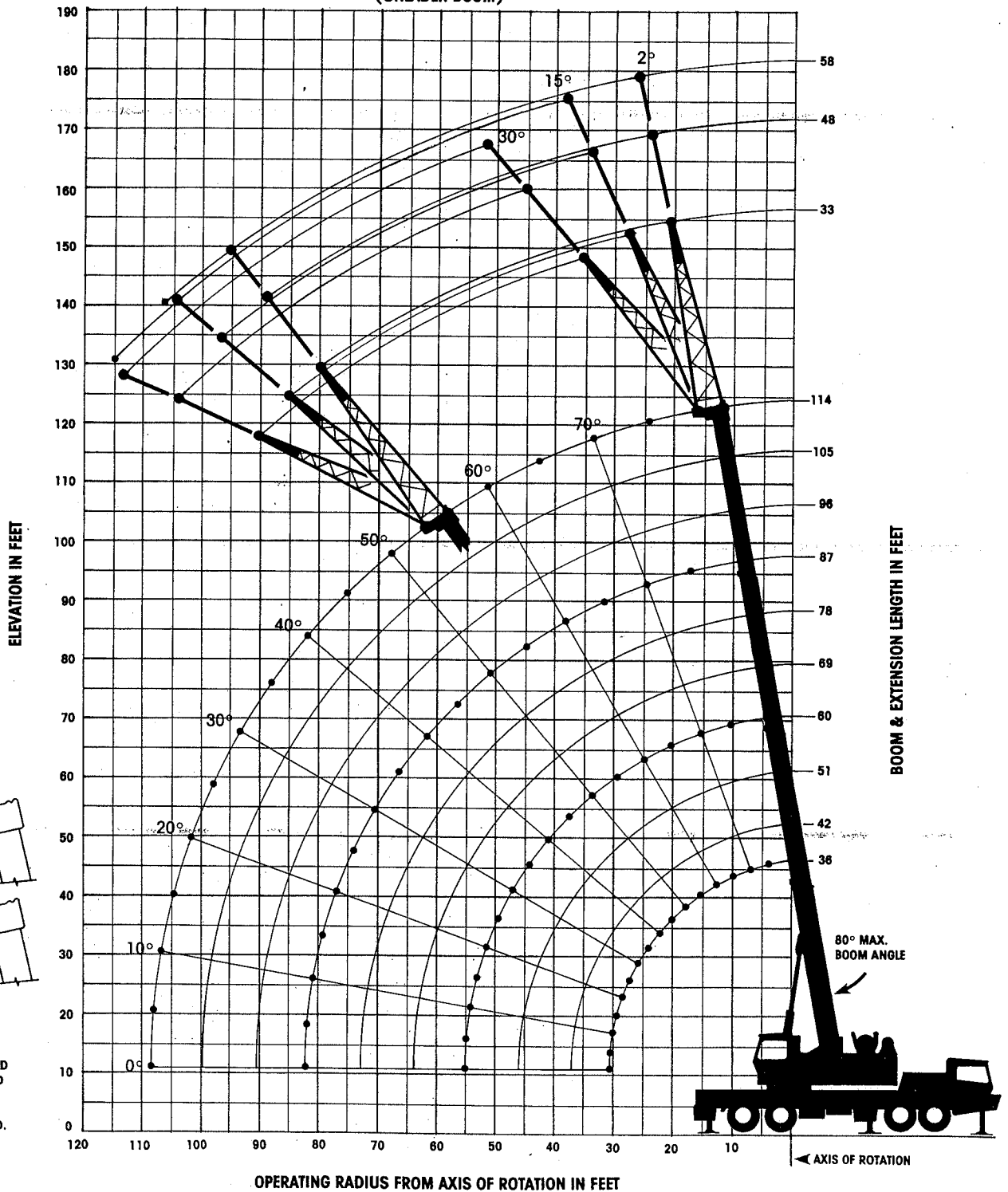

DIMENSIONS ARE FOR LARGEST GROVE FURNISHED HOOK BLOCK AND HEADACHE BALL, WITH ANTI-TWO BLOCK ACTIVATED.