

TMM400

SPECIFICATIONS



GROVE MANUFACTURING COMPANY

Division of Kidde, Inc.

KIDDE

SHADY GROVE, PA. 17256



SUPERSTRUCTURE SPECIFICATIONS

BOOM – 45 ft. – 173 ft. (13.7 m – 52.7 m) total length; 4-section trapezoidal main boom consisting of base section and 3 full power sections to 141 ft. (43 m) and a 32 ft. (9.8m) “Swingaway” (2° offset) lattice boom extension to 173 ft. (52.7 m).

*46 ft. – 205 ft. (14.0 m – 62.5 m) total length; 5-section trapezoidal main boom consisting of base section, 3 full power sections and 1 power pinned section to 173 ft. (52.7 m) and a 32 ft. (9.7 m) “Swingaway” lattice boom extension (2° offset) to 205 ft. (62.5 m).

Integral holding valves on each 7 in. (178.8 mm) bore double-acting telescope cylinder. Boom telescope sections are individually controlled and supported on graphite impregnated nylatron wear pads.

BOOM NOSE – Seven Metallic sheaves, 22 in. (559 mm) tread diameter, mounted on heavy duty tapered roller bearings. Removable pin type rope guards allow easy reeving. Rope dead ends on each side of boom nose. Removable single sheave 22 in. (559 mm) tread diameter auxiliary boom nose mounted to the main boom nose for single line work.

BOOM ELEVATION – Dual double-acting, 13 in. (330 mm) bore, hydraulic cylinders with integral holding valves. Elevation from –3° to 80°. Combination controls provided for hand or foot operation.

LOAD MOMENT AND ANTI-TWO BLOCK SYSTEM (KRUEGER) - Audio-visual warning in combination with Grove control lever lockout of; hoist-up, telescope-out and boom-down crane functions. Krueger LMI control console provides operator with selective display of boom length, radius and angle.

***POWER LUFFING JIB** – 14 ft. (4.3 m) lattice base section combines with the standard 32 ft. (9.7 m) “Swingaway” boom section to make basic 46 ft. (14.0 m) cable suspended power luffing jib. Additional 14 ft. (4.3 m) pinned insert available to make 60 ft. (18.3 m), 74 ft. (22.6 m) and 88 ft. (26.8 m) jib lengths. Luffing power is supplied from main hoist with 5° to 45° offset capability. Mast, pendant line, attaching hardware and backstops included in the makeup of all jib lengths. (Requires single sheave block for 2 part line operation).

CAB – Full vision, all-steel, fully-enclosed with acoustical treatment, tinted tempered safety glass throughout, hinged skylight, sliding left side door, sliding right side glass, door and window locks; fully-adjustable operator’s seat with headrest; 12,000 - BTU hot water heater; electric windshield wiper and circulating air fan, swing horn, domelight, dashlight; complete engine instrumentation and crane operating controls with adjustable full-length control levers, combination hand/foot controls for swing, boom

elevation and engine throttle; outrigger control panel, sight leveling bubble; electronic hoist drum rotations indicators for main and auxiliary hoists; Krueger LMI control console provides operator with selective display of boom length, radius and boom/jib angle; 3¾ lb. (1.7 kg) dry type fire extinguisher.

CAB INSTRUMENTATION – Engine oil pressure gauge, engine water temperature gauge, voltmeter, tachometer, fuel level gauge, ignition-on indicator light, hydraulic oil bypass indicator light, main hoist disengaged indicator light. Krueger control panel.

SWING – Roller bearing swing circle, 360° continuous rotation. Rockwell planetary “glide swing” with foot actuated disc swing brake, electric/hydraulic swing parking brake and 360° position positive turntable lock. Combination controls provided for hand or foot operation. Swing speed 1.9 RPM.

OUTRIGGER CONTROLS – Independently controlled in-out-up and down, from superstructure cab and either side of carrier frame. Required sequence control arrangement eliminates unintentional outrigger actuation. To insure proper outrigger retraction sequence, front jack cylinder retracts first when master switch is activated from any control station.

COUNTERWEIGHT – 15,700 lbs. (7121 kg) turntable mounted, power installed and removed, hydraulically extended to working position and retracted to stowed or travel position. (17,400 lbs. (7892 kg) counterweight used without auxiliary hoist).

HYDRAULIC SYSTEM:

RESERVOIR – 420 gallons (1589.7 liters) – all-steel welded construction with integral baffles, clean out access and exterior oil sight level gauge.

FILTER – Return line type, full flow with bypass protection and filter bypass indicator, replaceable cartridge. 25 micron rating.

PUMPS – Six sections, gear-type driven by superstructure engine. Manual pump disconnect located on lower right side of superstructure. Combined capacity 349 GPM (1321 lpm) @ 2400 RPM.

CONTROL VALVES – Precision four-way, double acting with integral load check, main and circuit relief valves. Six individual valve banks permit simultaneous independent control of five crane functions. Maximum system operating pressure 2500 PSI (175 kg/cm²).

OIL COOLER – Full flow, fin and tube, oil to air.

POWER DISTRIBUTION – (Lift boost) (Main hoist) (Aux. hoist and outer mid telescope) (Lift, main hoist boost and mid telescope) (Aux. hoist boost, inner mid telescope) (Swing, counterweight and outriggers).

**Denotes optional equipment*

HOIST SPECIFICATIONS

DESCRIPTION: Two speed and pull, planetary drive, power up and down with integral automatic brake.		DESCRIPTION: Series parallel circuitry and two motors provide both high line pull and speed ranges. Power up and down, equal speed, planetary reduction with integral automatic brake.		
HOIST DATA	MAIN HOIST Gearmatic Model 44 (see note below)		AUXILIARY HOIST Grove Model HO30B-26	
Drum Dimensions	20 in. dia. (508mm) 32 in. length (813mm) 30 in. flange dia. (762mm)		16 in. dia. (406mm) 26 in. length (660mm) 24 in. flange dia. (610mm)	
Performance: Max. Single Line Speed Max. Single Line Pull	Hi-Speed Range 360 FPM (109.7m/min) 14,000 lbs. (6350kg)	Lo-Speed Range 180 FPM (54.9m/min) 28,000 lbs. (12 700kg)	Hi-Speed Range 575 FPM (175.3m/min) 8,400 lbs. (3810kg)	Lo-Speed Range 290 FPM (88.4m/min) 16,800 lbs. (7620kg)
Drum Rope Capacity	**1000 ft. of 1 in. dia. rope (304.8m of 25mm)		**1060 ft. of ¾ in. dia. rope (323.1m of 19mm)	
Permissible Single Line Rope Pull (5:1 safety factor)	1 in. (25mm) 18x19 class EIPS, WSC 20,400 lbs. (9253kg)		¾ in. (19mm) 18x19 class EIPS, WSC 11,500 lbs. (5216kg)	

**6th layer of rope not recommended for hoisting operations.

NOTE: The Gearmatic Model 44 hoist with controlled free fall is available as the optional main hoist with the same specifications as shown above.

SUPERSTRUCTURE ENGINE SPECIFICATIONS

	GM6V-53N	*Cummins V555-C230	*Caterpillar 3208
MAKE & MODEL	GM6V-53N	*Cummins V555-C230	*Caterpillar 3208
TYPE	8 Cylinder O.H.V.	6 Cylinder O.H.V.	8 Cylinder O.H.V.
BORE & STROKE	4.625 in. x 4.125 in. (117mm x 105mm)	3.875 in. x 4.5 in. (98mm x 114mm)	4.5 in. x 5.0 in. (114mm x 127mm)
DISPLACEMENT	555 cu. in. (9096cm ³)	318 cu. in. (5212cm ³)	636 cu. in. (10 424cm ³)
HORSEPOWER (NET)	199 @ 3000 RPM	196 @ 2800 RPM	199 @ 2800 RPM
GOVERNED RPM	3000	2800	2800
TORQUE (NET)	394 lbs. ft. (54kg.m) @ 1800 RPM	427 lbs. ft. (59kg.m) @ 1500 RPM	446 lbs. ft. (62kg.m) @ 1400 RPM
ELECTRICAL SYSTEM	12 volt neg. ground	12 volt neg. ground	12 volt neg. ground
COMBUSTION SYSTEM	4 cycle naturally aspirated	2 cycle with blower	4 cycle naturally aspirated
COOLING SYSTEM	Liquid	Liquid	Liquid
FUEL CAPACITY	60 Gallons (227 liters)	60 Gallons (227 liters)	60 Gallons (227 liters)
ALTERNATOR	90 Amp 12 volt	90 Amp 12 volt	90 Amp 12 volt
BATTERY	(4) 12-volt 475 CCA @ 0°F	(4) 12-volt 475 CCA @ 0°F	(4) 12-volt 475 CCA @ 0°F
AIR CLEANER	Dry Type	Dry Type	Dry Type
HOURMETER	Yes (10,000 HR)	Yes (10,000 HR)	Yes (10,000 HR)
STARTING SYSTEM	24 volt	24 volt	24 volt

NOTE: Performance data will vary plus or minus 10% due to variations in engine performance & operating conditions.

*Denotes optional equipment.

The name Grove and the Trapezoidal shape are registered trademarks of Grove Manufacturing Co.

DIMENSIONS

TURNING RADIUS 51 ft. (15 545)

TAIL SWING 13 ft. 3¹/₈ in. (4041) (Counterweight in travel position)

TAIL SWING 16 ft. 2³/₄ in. (4946) (Counterweight in working position)

NOTE: Dimensions shown in parenthesis are millimeters (mm).

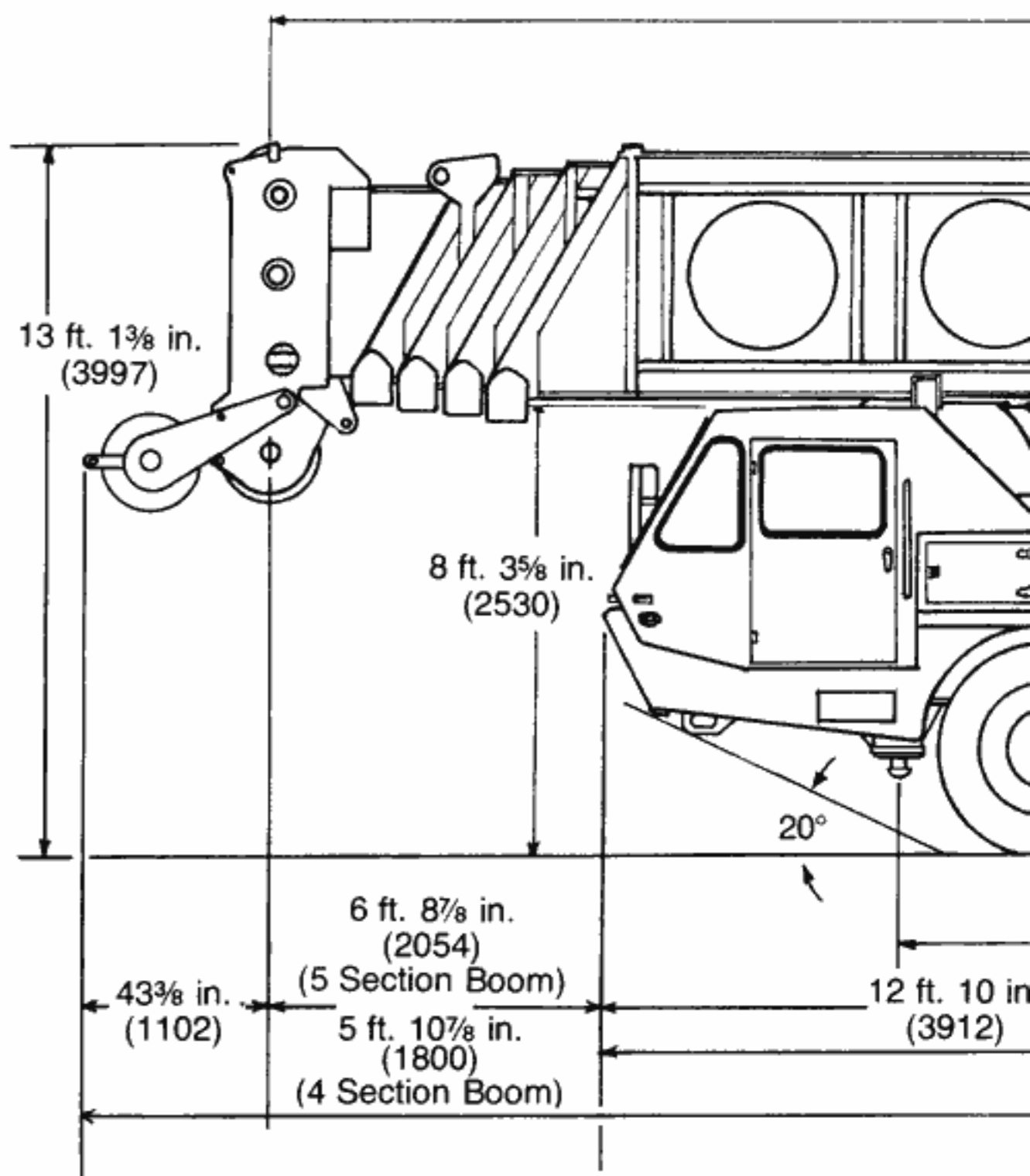
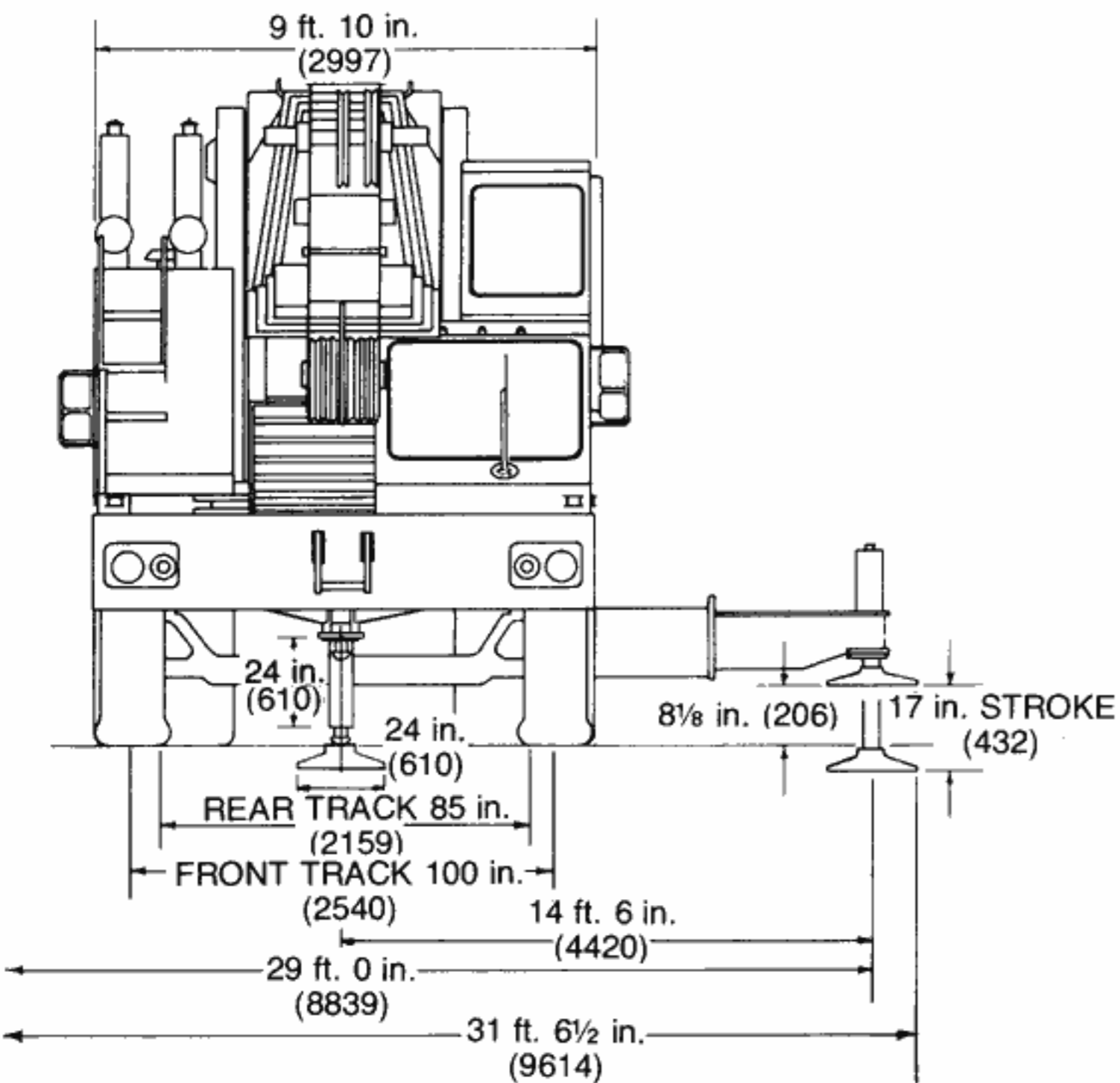



TURNING RADIUS 51 ft. (15 545)
 TAIL SWING 13 ft. 3/8 in. (4041) (Counterweight in travel position)
 TAIL SWING 16 ft. 2/4 in. (4946) (Counterweight in working position)

NOTE: Dimensions shown in parenthesis are millimeters (mm).

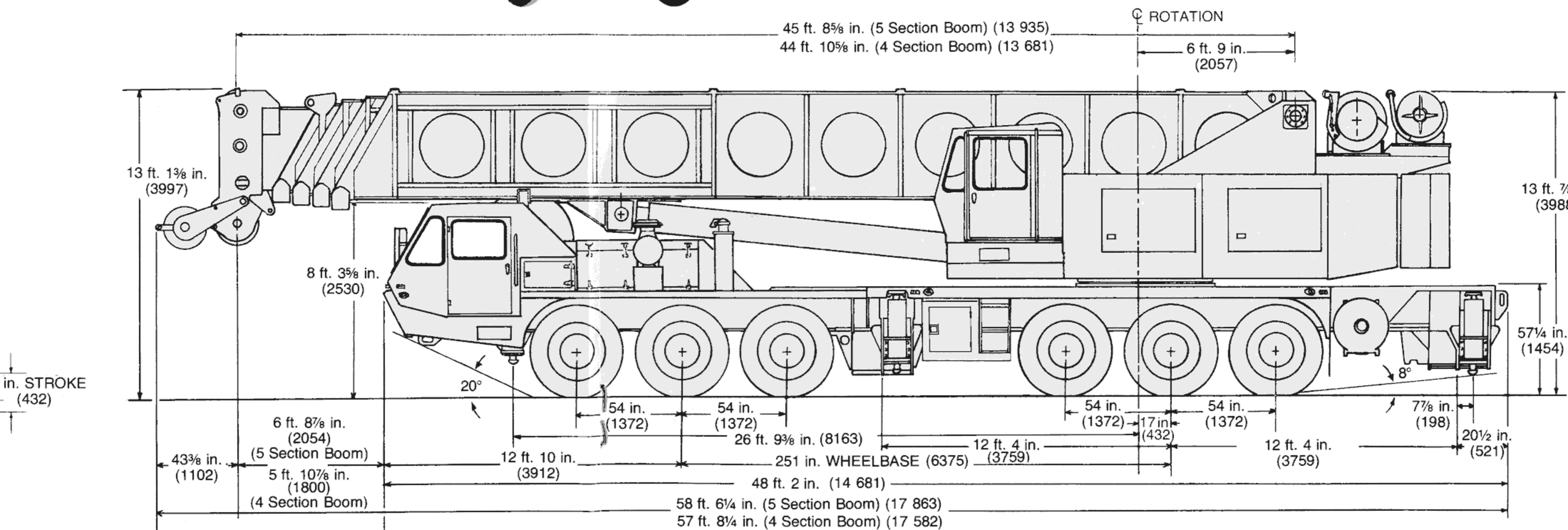



CARRIER SPECIFICATIONS

OUTRIGGERS – Hydraulic double box 2-stage telescoping beam outriggers, integral welded boxes, removable beams, vertical 8¼ in. (210 mm) bore, double-acting jack cylinders with integral holding valves and 30½ in. (775 mm) dia. steel floats. Beams extend to 29 ft. (8.8 m) centerline-to-centerline, by 3 in. (76 mm) bore, double-acting cylinders, retract to 9 ft. 10 in. (3.0 m) overall width. Mechanical spin locks on each vertical jack to secure outriggers at any level. Controls and sight leveling bubble located in superstructure cab and each side of carrier frame. Powered by superstructure engine.

FRONT END STABILIZER – A fifth hydraulic vertical outrigger jack cylinder, with integral holding valve, mounted to the front frame section of chassis to permit 360° lifting capabilities. 24 in. (610 mm) dia. steel float is easily removed for highway travel. Individual controls for fifth outrigger cylinder are conveniently located in superstructure cab and each side of carrier frame.

FRAME – High-strength steel, all-welded construction of box-type design with integral welded outrigger boxes.

STEERING GEAR – Ross cam and lever type with Garrison hydraulic power assist.

CLUTCH – Lipe Rollway 15½ in. (394 mm), two plate dry disc.

TRANSMISSION – Fuller Roadranger (RTO 12509) 9-speeds forward, 2 reverse, with Fuller AT1202 2-speed auxiliary.

UNIVERSAL JOINTS – Needle bearing type.

AXLES – Front: (3) Rockwell tubular steering FL951 100 in. track. 66,000 lbs. (29 937 kg) capacity.

Rear: (3) Rockwell EPRC 1735 Planetary drive 85 in. (2159 mm) track. 134,000 lbs. (60 782 kg) capacity.

SUSPENSION – Front: Reyco 21B spring mounted tridem, 66,000 lbs. (29 938 kg) capacity. Rear: Hendrickson tri-axle equalizing beam with solid steel saddles 134,000 lbs. (60 782 kg) capacity.

FUEL TANK – Single 100 gal. (379 liters) capacity mounted on right side of frame.

TIRES – Michelin 14:00x20-22 ply rated (G-20X) radial tube-type front and rear.

TIRE INFLATION KIT – Quick connect air outlet located at midpoint on either side of carrier. Includes dual foot air chuck and 25 ft. (7.6 m) coiled nylon tubing.

WHEELS – Steel spoke 10 in. x 20 in. (254 mm x 508 mm).

BRAKES – Full air on all wheels. Front 15 in. x 6 in. (381 mm x 152 mm). Rear 17¼ in. x 5½ in. (438 mm x 140 mm). Total lining area 2137 sq. in. (13 788 cm²). Air dryer provided to preclude system damaging moisture accumulation.

PARKING BRAKE – Maxi-type, spring set emergency chambers on all rear axles with emergency release kit.

ELECTRICAL SYSTEM – 12-volt lighting, 24-volt starting. Federal safety standard lights and reflectors.

CAB – Two-man low profile design, all steel with acoustical treatment, tinted tempered safety glass throughout (front windshield is tinted laminated); windshield washer and electric wiper, door and window locks, Bostrom “T” bar drivers seat and Bostrom companion seat, seat belts, heater, defroster fan, dual mirrors, domelight, dashlight, electric horn, traffic hazard warning switch (4-way flasher), complete instrumentation and driving controls, sliding right side and roll-down left side glass for ventilation, 3¾ lbs. (1.7 kg) dry type fire extinguisher.

CAB INSTRUMENTATION – Engine oil pressure gauge, speedometer, air pressure gauge, fuel level gauge, engine water temperature gauge, voltmeter, tachometer, low air pressure audio-visual warning device, high beam indicator, ignition-on indicator.

MISCELLANEOUS STANDARD EQUIPMENT – Wheel nut wrench and handle, channel type front bumper, two front and rear towing loops, front and rear fenders, lifting lugs, mud flaps, ether injection starting air (less canister), tool storage compartment, trailer air and electrical disconnects, sling box, hook block storage trough.

**Denotes optional equipment*

SPEED AND GRADEABILITY

Engine	Speed Ranges at Maximum Governed RPM		% of Gradeability at Maximum Torque	
	Aux. Low	Aux. Direct	Aux. Low	Aux. Direct
GM8V-92T Cummins KT450 Cat 3408TA	1.64-20.49 (2.64-33Km/HR)	3.34-41.8 (5.37-67.3Km/HR)	49.34 to 2.56 54.62 to 2.98 54.62 to 2.98	23.42 to .49% 26.01 to .70% 26.01 to .70%

NOTE: Performance based on 190,000 lbs. (86 184kg) GVW and standard SAE engine rating conditions using standard tires, transmissions and axles. Performance data may vary plus or minus 10% due to variations in engine performance and vehicle weights. Maximum speed restricted to 40 MPH (64.4Km/HR) due to tire limitations.

CARRIER ENGINE SPECIFICATIONS

MAKE & MODEL	GM8V-92T	*Cummins KT450	*Caterpillar 3408TA ††
TYPE	8 Cylinder O.H.V.	6 Cylinder O.H.V.	8 Cylinder O.H.V.
BORE & STROKE	4.84 in. x 5.0 in. (123mm x 127mm)	6.25 in. x 6.25 in. (159mm x 159mm)	5.4 in. x 6.0 in. (137mm x 152mm)
DISPLACEMENT	736 cu. in. (12 063cm ³)	1150 cu. in. (18 849cm ³)	1099 cu. in. (18 013cm ³)
HORSEPOWER (NET)	387 @ 2100 RPM	399 @ 2100 RPM	398 @ 2100 RPM
GOVERNED RPM	2100	2100	2100
TORQUE (NET)	1,144 lbs. ft. (158 kg.m) @ 1400 RPM	1,250 lbs. ft. (173 kg.m) @ 1450 RPM	1,222 lbs. ft.(169 kg.m) @ 1500 RPM
ELECTRICAL SYSTEM	12-volt neg. ground	12-volt neg. ground	12-volt neg. ground
COMBUSTION SYSTEM	2 cycle turbocharged	4 cycle turbocharged	4 cycle turbocharged
COOLING SYSTEM	Liquid	Liquid	Liquid
FUEL CAPACITY	100 Gallons (379 liters)	100 Gallons (379 liters)	100 Gallons (379 liters)
ALTERNATOR	90 Amp 12-volt	90 Amp 12-volt	90 Amp 12-volt
BATTERY	(4) 12-volt 475 CCA @ 0°F	(4) 12-volt 475 CCA @ 0°F	(4) 12-volt 475 CCA @ 0°F
AIR CLEANER	Dry Type	Dry Type	Dry Type
AIR COMPRESSOR	24 CFM (11 L/sec)	30 CFM (14 L/sec)	24 CFM (11 L/sec)
HOURMETER	Yes (10,000 HR)	Yes (10,000 HR)	Yes (10,000 HR)
STARTING SYSTEM	24-volt	24-volt	24-volt

Note: GM and Cummins engines equipped with Jacobs engine brake. Units with Caterpillar engine are equipped with brake saver.

*Denotes optional equipment.

††Meets 1979 California air emissions standards.

AXLE WEIGHT DISTRIBUTION CHART

ITEM	POUNDS			KILOGRAMS		
	GROSS	FRONT	REAR	GROSS	FRONT	REAR
Basic machine to include: 46 ft. - 173 ft. (14m - 52.7m) Trapezoidal Boom plus a 32 ft. (9.8m) "Swingaway" extension. Gearmatic model 44 hoist with 950 ft. (289.5m) of 1 in. (25mm) dia. rope. Grove model HO30B-26 auxiliary hoist with 750 ft. (228.6m) of ¾ in. (19mm) dia. rope, **15,700 lb. (7122kg) counterweight, Grove model 12 x 6 - 140 ton carrier, GM8V92T carrier engine and GM6V53N (superstructure engine). Auxiliary boom nose, Krueger LMI.	189,934	54,484	135,450	86 154	24 714	61 440
Add: 140 ton hook block	+3,447	+5,315	-1,868	+1564	+2411	-847
Add: 30 ton hook block	+1,022	+1,576	-554	+464	+715	-252
Substitute: ***17,400 lb. (7893kg) counterweight and remove standard model HO30B-26 auxiliary hoist with rope	-1,111	+575	-1,686	-504	+261	-765
Substitute: 45 ft. - 141 ft. (13.7m - 42.9m) boom	-4,168	-3,899	-269	-1891	-1769	-122
Substitute: gearmatic model 44 main hoist with free fall	+200	-76	+276	+91	-34	+125
Substitute: Cummins diesel engines	+1,420	+1,447	-27	+644	+656	-12
Substitute: Caterpillar diesel engines	+795	+644	+151	+361	+292	+69
Remove: standard **15,700 lb. (7122kg) counterweight	-15,700	+7,877	-23,577	-7122	+3571	-10 693
Remove: standard auxiliary boom head	-253	-511	+258	-115	-232	+117
Remove: 46 ft. - 173 ft. (14m - 52.7m) boom and lift cylinders	-54,053	-42,300	-11,753	-24 518	-19 187	-5331
Remove: standard main hoist with rope	-4,745	+1,805	-6,550	-2152	+819	-2971
Remove: 32 ft. (9.8m) "Swingaway" extension and brackets	-2,133	-2,585	+452	-968	-459	-509
Remove: front outrigger beams	-8,300	-4,894	-3,406	-3765	-2220	-1545
Remove: rear outrigger beams	-8,300	+4,894	-13,194	-3765	+2220	-5985

**Use standard 15,700 lb. (7122kg) counterweight with HO30B-26 auxiliary hoist.

***Use 17,400 lb. (7893kg) counterweight without auxiliary hoist.

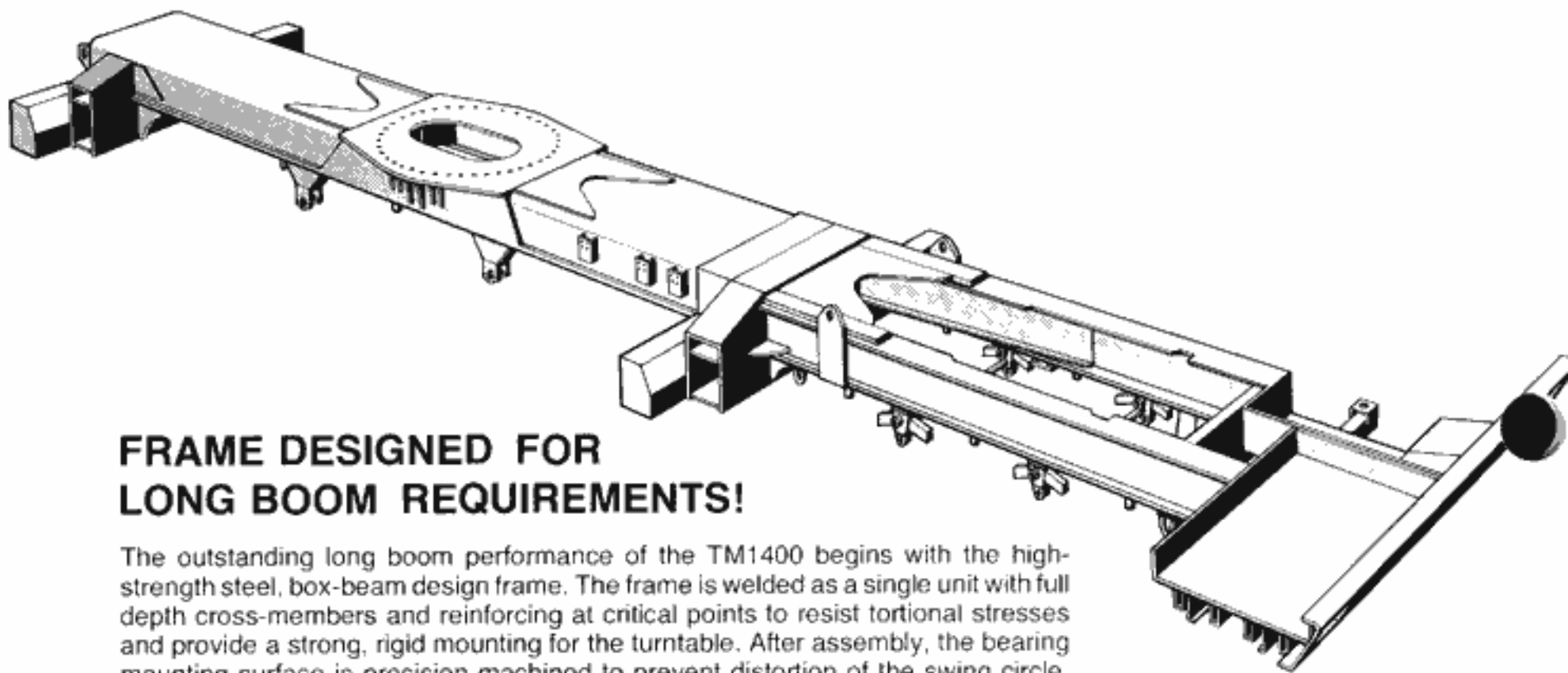

FRAME DESIGNED FOR LONG BOOM REQUIREMENTS!

The outstanding long boom performance of the TM1400 begins with the high-strength steel, box-beam design frame. The frame is welded as a single unit with full depth cross-members and reinforcing at critical points to resist torsional stresses and provide a strong, rigid mounting for the turntable. After assembly, the bearing mounting surface is precision machined to prevent distortion of the swing circle. Outrigger boxes are integral with the frame to provide additional strength and stability, especially in long boom operations.

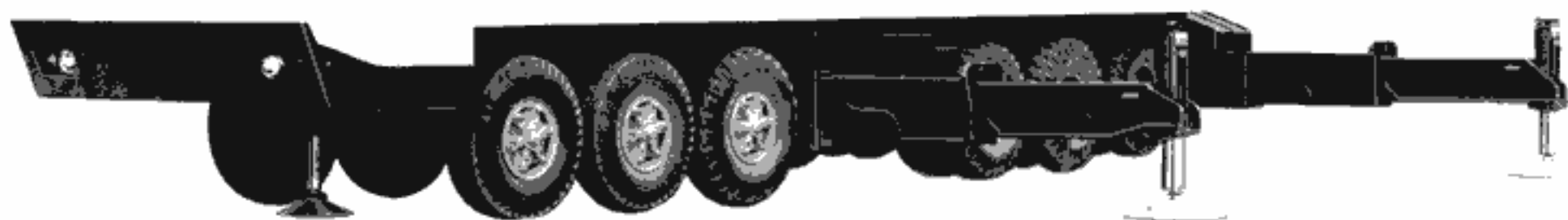

WIDE OUTRIGGER STANCE . . . QUICK-SET-UP . . . 360 OPERATION!

Hydraulic double box two-stage telescoping beam outriggers extend to 29 feet, providing the stability for high capacity lifts and long boom operation. Beams and jacks are independently controlled for quick set-up. Controls are located on either side of the chassis and in the superstructure cab, with a leveling bubble at each location. A fifth vertical jack, integral with forward frame members, provides the stability for 360 degree lifts and is standard equipment. All vertical jacks are equipped with holding valves, and those mounted on the beams are also equipped with the Grove Spin-lock† for positive locking of the jacks at any level.