

GROVE™ TM 1275

**HYDRAULIC CRANE with
TRAPEZOIDAL BOOM**

125-TON CAPACITY

†Patented Grove Feature



**HYDRAULIC
CRANES**

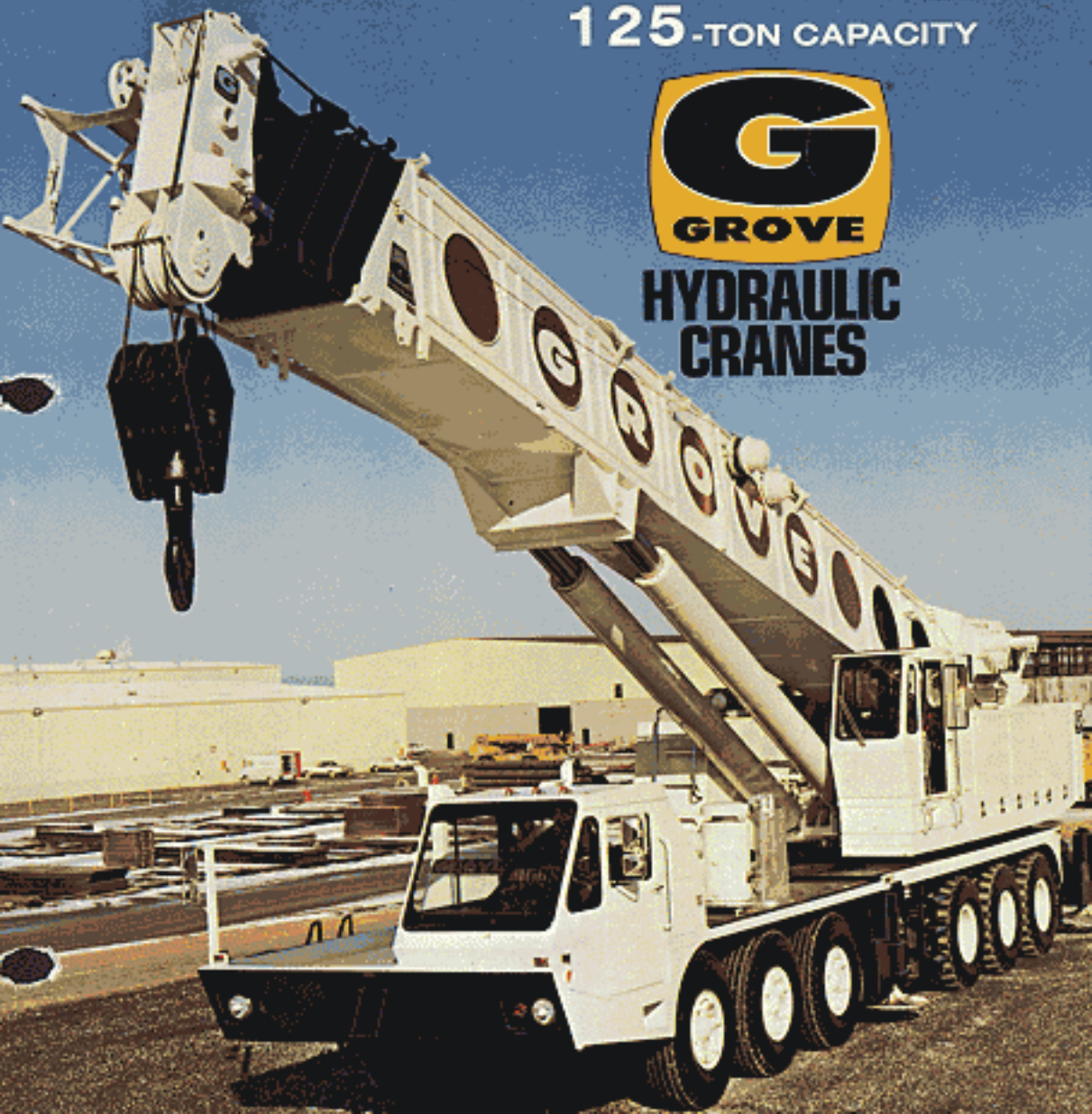

THE GROVE TRAPEZOIDAL BOOM

A major accomplishment in hydraulic telescoping boom design.

Grove has perfected several versions of the basic Trapezoidal Boom design, and as first introduced, the trapezoidal design provided far more strength and rigidity at longer reaches and higher capacities than a conventional design, with no increase in boom weight.

The search for a new approach to still stronger and lighter booms led to the design introduced on the Model TM1275 Crane. Side-plate holes provide reduction in boom weight and specially welded-in reinforcing rings provide the stiffening for added strength.

A "swing-around" boom section which stows laterally alongside the base section is standard on the TM1275. In working position it provides a tip height of 212 ft. (64.62m). Additional inserts may be added to create an 88 ft. jib reaching to a tip height of 267 ft. (81.38m). The jib is cable suspended and offset from a minimum of 5° to a maximum of 30°.

BOOM REMOVAL SYSTEM

To meet highway weight limitations in certain areas, the boom, lift cylinders and counterweight of the TM1275 can be removed with a minimum of time and manpower. A specially equipped optional trailer with load handling device is used to receive and transport these components. All trailer transfer functions are powered directly from the cranes hydraulic system.

With 88' jib

6710 lbs.
(3044kgs)

@ 267' TIP HEIGHT
(81.38m)

21,500 lbs. @ 212' TIP HEIGHT
(9752kgs) (64.62m)

35,000 lbs. @ 181' TIP HEIGHT
(15 876kgs) (55.17m)

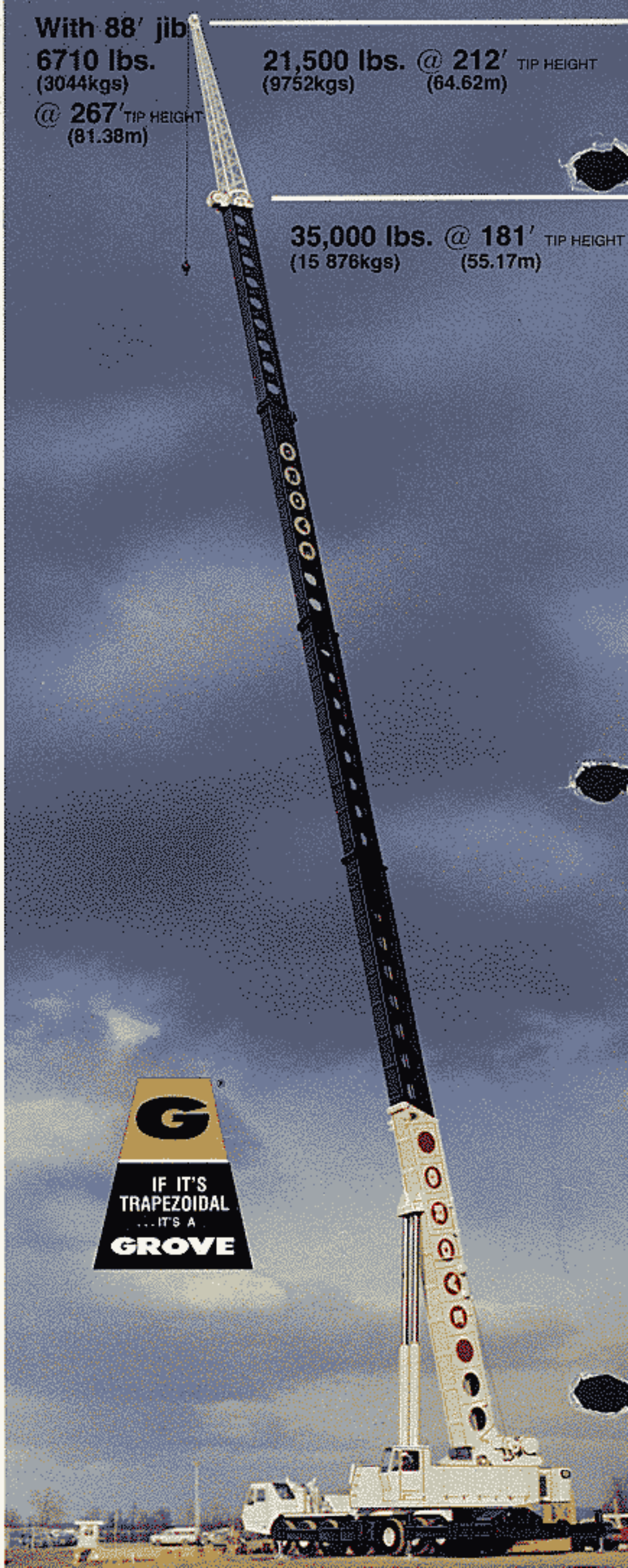



SUPERSTRUCTURE SPECIFICATIONS

BOOM – 46 ft. – 205 ft. (14.02m – 62.48m), 6 section; 3 full power and 1 power pinned trapezoidal sections to 173 ft. (52.73m) plus a 32 ft. (9.75m) "Swingaway" lattice extension (2° offset). Integral check valves on each telescoping cylinder. Boom telescope sections are individually controlled and supported on graphite impregnated nylatron wear pads.

BOOM NOSE – Six sheaves mounted on heavy duty tapered roller bearings. Removable pin type rope guards allow easy reeving. Rope dead ends on each side of boom nose. Single sheave auxiliary boom head.

BOOM ELEVATION – Dual double acting hydraulic cylinders with integral holding valves. Elevation from –3° to 80°. Combination controls provided for hand or foot operation.

LOAD MOMENT AND ANTI-TWO BLOCK SYSTEM (KRUGER) – Audio-visual warning in combination with Grove control lever lockout of: hoist up, telescope out, and boom down functions.

JIBS – 14 ft. (4.27m) lattice base section combines with the standard 32 ft. (9.75m) "Swingaway" boom section to make basic 46 ft. (14.02m) jib. Additional 14 ft. (4.27m) pinned inserts available to make 60 ft. (18.29m), 74 ft. (22.56m), and 88 ft. (26.82m) jib lengths. Mast, pendant lines, attaching hardware and backstops included in the make-up of all jib lengths. Jib sheave mounted on tapered roller bearings. The jib is cable suspended and offset from a minimum of 5° to a maximum of 30°.

CAB – Full vision, all-steel, fully enclosed with acoustical treatment, laminated safety glass throughout; removable windshield with storage provisions, hinged tinted skylight, sliding left side door, rear vent window, sliding right side glass, door and window locks; fully adjustable operator's seat with head rest, hot water heater, electric windshield wiper and defroster fan, swing horn, domelight, dash light; complete engine instrumentation and crane operating controls, outrigger control panel, adjustable full length control levers, combination hand/foot controls for swing, boom elevation and engine throttle. Hoist drum rotation indicators for main and auxiliary hoist, sight leveling bubble, electronic boom angle indicator, 2¾ lb. (1.25kg) dry type fire extinguisher. (Air conditioning available)

CAB INSTRUMENTATION – Engine oil pressure gauge, engine water temperature gauge, voltmeter, tachometer, fuel level gauge, ignition-on indicator light, stalled engine indicator light, hydraulic oil by-pass indicator light, main hoist disengaged indicator light.

SWING – Roller bearing swing circle, 360° continuous rotation. Rockwell planetary "glide swing" with foot actuated disc swing brake, hand operated turntable brake and 360° position positive turntable lock. Combination controls provided for hand or foot operation. Swing speed 1.9 RPM.

OUTRIGGER CONTROLS – Independently controlled in-out-up and down, from superstructure cab and either side of carrier frame. Sequence control design eliminates accidental outrigger actuation. Sight level bubbles at each control station.

COUNTERWEIGHT – 18,300 lb. (8301kgs) turntable mounted, power installed and removed, hydraulically extended to working position and retracted to stowed or travel position. (20,000 lb. (9072kgs) counterweight used without auxiliary hoist)

HYDRAULIC SYSTEM:

RESERVOIR – 423 gallons (1601 liters), all-steel welded construction with integral baffles, clean out access and exterior oil sight level.

FILTER – Return line type, full flow with by-pass protection and filter by-pass indicator, replaceable cartridge. 25 micron rating.

PUMPS – Six section, gear-type driven by superstructure engine. Manual pump disconnect located on lower right side of superstructure. Combined capacity 349 GPM (1321 lpm).

CONTROL VALVES – Precision four-way, double-acting with integral load check, main and circuit relief valves. Six individual valve banks permit simultaneous independent control of five crane functions. Maximum system operating pressure 2500 PSI (175kgs/cm²).

OIL COOLER – Full flow, fin and tube, oil to air.

POWER DISTRIBUTION – (Auxiliary hoist boost, inner mid telescope) (Swing) (Lift) (Lift boost, main hoist boost) (Outer mid telescope, auxiliary hoist) (Main hoist)

*Denotes Optional Equipment

HOIST SPECIFICATIONS

DESCRIPTION: Two speed and pull, planetary drive, power up and down with integral automatic brake.		DESCRIPTION: Series parallel circuitry and two motors provide both high line pull and speed ranges. Power up and down, equal speed, planetary reduction with integral automatic brake.	
HOIST DATA	MAIN HOIST Gearmatic Model 44 (see note below)		AUXILIARY HOIST Grove Model 32S-1726A
Drum Dimensions	20 in. diameter (508mm) 26 in. length (660mm) 30 in. flange dia. (762mm)		16 in. diameter (406mm) 26 in. length (660mm) 24 in. flange dia. (610mm)
Performance: Max. Single Line Speed Max. Single Line Pull	Hi-Speed Range 355 FPM (108.2m/min) 14,000 lbs. (6350kgs)	Lo-Speed Range 177 FPM (53.95m/min) 28,000 lbs. (12 700kgs)	Hi-Speed Range 575 FPM (175.26m/min) 8400 lbs. (3810kgs) Lo-Speed Range 290 FPM (88.39m/min) 16,800 lbs. (7620kgs)
Drum Rope Storage Capacity	**1140 ft. of 7/8 in. dia. rope (347.47m of 22mm)		††1060 ft. of 3/4 in. dia. rope (323.09m of 19mm)
Permissible Single Line Rope	7/8 in. (22mm) 8x25 class - 20,000 lbs. (9072kgs) 7/8 in. (22mm) 19x7 class - 18,550 lbs. (8414kgs)		3/4 in. (19mm) 8x25 class - 14,605 lbs. (6625kgs) 3/4 in. (19mm) 19x7 class - 13,700 lbs. (6214kgs)

**6th layer of rope not recommended for hoisting operations.
††6th layer of rope not recommended for hoisting operations.

NOTE: The Gearmatic Model 44 hoist with controlled free fall is available as the optional main hoist with the same specifications as shown above.

SUPERSTRUCTURE ENGINE SPECIFICATIONS

MAKE & MODEL	Cummins V555-C230	*GM6V-53N	*Caterpillar 3208
TYPE	8 Cylinder O.H.V.	6 Cylinder O.H.V.	8 Cylinder O.H.V.
BORE & STROKE	4.625 in. x 4.125 in. (117mm x 105mm)	3.875 in. x 4.5 in. (98mm x 114mm)	4.5 in. x 5.0 in. (114mm x 127mm)
DISPLACEMENT	555 cu.in. (9096cm ³)	318 cu.in. (5212cm ³)	636 cu.in. (10 424cm ³)
HORSEPOWER (NET)	212 @ 3300 RPM	199 @ 2800 RPM	199 @ 2800 RPM
GOVERNED RPM	3300	2800	2800
TORQUE (NET)	394 lbs. ft. @ 1800 RPM	412 lbs. ft. @ 1500 RPM	450 lbs. ft. @ 1400 RPM
ELECTRICAL SYSTEM	12 volt neg. ground	12 volt neg. ground	12 volt neg. ground
COMBUSTION SYSTEM	4 cycle naturally aspirated	2 cycle with blower	4 cycle naturally aspirated
COOLING SYSTEM	Liquid	Liquid	Liquid
FUEL CAPACITY	60 Gallons (227 liters)	60 Gallons (227 liters)	60 Gallons (227 liters)
ALTERNATOR	58 Amp 12 volt	62 Amp 12 volt	55 Amp 12 volt
BATTERY	(2) 204 A.H. 12 volt	(2) 204 A.H. 12 volt	(2) 204 A.H. 12 volt
AIR CLEANER	Dry Type	Dry Type	Dry Type
HOURMETER	Yes	Yes	Yes

Note: With air conditioning, engine horsepower and performance will be slightly reduced.

*Denotes Optional Equipment



The name Grove and the Trapezoidal shape are registered trademarks of Grove Manufacturing Co.

CARRIER SPECIFICATIONS



OUTRIGGERS – Hydraulic double box 2-stage telescoping beam outriggers, integral welded boxes, removable beams, vertical jack cylinders with integral holding valves and 30½ in. (775mm) diameter aluminum forged floats. Beams extend to 29 ft. (8.83m) centerline to centerline, retract to 9 ft. 10 in. (3.0m) overall width. Mechanical spin locks on each vertical jack to secure outriggers at any level. Controls and sight leveling bubble located in superstructure cab and each side of carrier frame. Powered by superstructure engine.

FRONT END STABILIZER – A fifth hydraulic vertical outrigger jack cylinder, with integral holding valve, mounted to the front frame section of chassis to permit 360° lifting capabilities. Forged aluminum float is easily removed for highway travel. Individual controls for fifth outrigger cylinder are conveniently located in superstructure cab and each side of carrier frame.

FRAME – High-strength steel, all-welded construction with box-type design and integral welded outrigger boxes.

STEERING GEAR – Ross TE-72740 cam and lever type with Garrison hydraulic power assist.

CLUTCH – Lipe Rollway 15½ in. (394mm), two plate, dry disc.

TRANSMISSION – Fuller Roadranger RTO12515, 15 speeds forward and 3 reverse.

UNIVERSAL JOINTS – Needle bearing type.

AXLES – Front: (3) Shuler tubular steering DCB34-L-12, 100 in. (2.54m) track, 66,750 lbs. (30 278kgs) capacity.
Rear: (3) Clark BD65200 Planetary, 85 in. (2.16m) track, 127,500 lbs. (57 834kgs) capacity.

SUSPENSION – Front: Reyco 21B spring mounted tridem, 66,000 lbs. (29 938kgs) capacity. Rear: Hendrickson tri-axle equalizing beam with solid steel saddles, 127,500 lbs. (57 834kgs) capacity.

FUEL TANK – Single 100 gallons (379 liters) capacity mounted on right side of frame.

TIRES – 14:00X20 – 20 ply Tube-type, Hi-way tread front, ND-M & S tread rear.

WHEELS – Steel spoke 10 in. x 20 in. (254mm x 508mm).

BRAKES – Full air on all wheels. Front: 17¼ in. x 4 in. (438mm x 102mm). Rear: 16½ in. x 7 in. (419mm x 178mm). Total lining area: 2130 sq.in. (13 743cm²). Drive line mounted electro-magnetic retarder with cab mounted control.

PARKING BRAKE – Maxi-type, spring set emergency chambers on all rear axles with emergency release kit.

ELECTRICAL SYSTEM – 12 volt lighting, 24 volt starting. Federal safety standard lights and reflectors.

CAB – Two-man low profile design, all-steel with acoustical treatment, laminated safety glass windshield and windows throughout; windshield washer and electric wiper, door and window locks, Bostrom "T" bar drivers seat and Bostrom companion seat, seat belts, heater, defroster fan, dual West Coast mirrors, domelight, dashlight, electric horn, traffic hazard warning switch (4-way flasher), complete instrumentation and driving controls, sliding right side and roll-down left side glass for ventilation, 2¾ lb. (1.25kgs) dry type fire extinguisher. (Air conditioning available).

CAB INSTRUMENTATION – Engine oil pressure gauge, speedometer, air pressure gauge, fuel level gauge, engine water temperature gauge, voltmeter, tachometer, low air pressure audio-visual warning device, high beam indicator, ignition-on indicator.

MISCELLANEOUS STANDARD EQUIPMENT – Wheel nut wrench and handle, channel type front bumper, two front and rear towing loops, front and rear fenders, ether injection starting aid (less canister), front bumper mounted tie down, mud flaps, tool storage compartment, trailer air and electrical disconnects.

SPEED AND GRADEABILITY

CARRIER ENGINE SPECIFICATIONS

Engine	Speed Ranges @ Max. Governed RPM	% of Gradeability @ Max. Torque
Cummins KT450	3.04 to 42.11 MPH (4 to 68 Km/h)	28.92 to .70%
*GM 8V-92T	3.04 to 42.11 MPH (4 to 68 Km/h)	25.32 to .44%
*Caterpillar 3408T	3.04 to 42.11 MPH (4 to 68 Km/h)	28.92 to .70%

MAKE & MODEL TYPE	Cummins KT450	*GM 8V-92T	*Caterpillar 3408T
BORE & STROKE	6 Cylinder O.H.V. 6.25 in. x 6.25 in. (159mm x 159mm)	8 Cylinder O.H.V. 4.84 in. x 5.0 in. (123mm x 127mm)	8 Cylinder O.H.V. 5.4 in. x 6.0 in. (137mm x 152mm)
DISPLACEMENT	1150 cu.in. (18 849cm³)	736 cu.in. (12 063cm³)	1099 cu.in. (18 013cm³)
HORSEPOWER (NET)	405 @ 2200 RPM	387 @ 2100 RPM	383 @ 2200 RPM
GOVERNED RPM	2200	2100	2200
TORQUE (NET)	1170 lbs. ft. @ 1550 RPM	1044 lbs. ft. @ 1600 RPM	1051 lbs. ft. @ 1320 RPM
ELECTRICAL SYSTEM	12 volt neg. ground	12 volt neg. ground	12 volt neg. ground
COMBUSTION SYSTEM	4 cycle turbocharged	2 cycle turbocharged	4 cycle turbocharged
COOLING SYSTEM	Liquid	Liquid	Liquid
FUEL CAPACITY	100 Gallons (379 liters)	100 Gallons (379 liters)	100 Gallons (379 liters)
ALTERNATOR	75 Amp 12 volt	75 Amp 12 volt	65 Amp 12 volt
BATTERY	(2) 204 A.H. 12 volt	(2) 204 A.H. 12 volt	(2) 204 A.H. 12 volt
AIR CLEANER	Dry Type	Dry Type	Dry Type
AIR COMPRESSOR	13.2 CFM	12 CFM	12 CFM
HOURMETER	Yes	Yes	Yes
STARTING SYSTEM	24 volt	24 volt	24 volt

NOTE: Performance based on 180,000 lb. (81 648kgs) GVW and standard SAE engine rating conditions using standard tires, transmissions and axles. Performance data may vary plus or minus 10% due to variations in engine performance and vehicle weights.

Note: With air conditioning, engine horsepower and performance will be slightly reduced.

*Denotes Optional Equipment

AXLE WEIGHT DISTRIBUTION CHART

ITEM	POUNDS			KILOGRAMS		
	GROSS	FRONT	REAR	GROSS	FRONT	REAR
Basic standard machine to include: 46 ft. to 173 ft. (14.02-52.73m) Trapezoidal boom plus a 32 ft. (9.75m) Swingaway extension Gearmatic model 44 main hoist with 900 ft. (274.32m) of ¾ in. (22mm) rope, Grove model 32S-1726A auxiliary hoist with 750 ft. (286.6m) of ¾ in. (19mm) rope, 18,300 lbs. (8301kgs) counterweight, Grove model 12x6-125 carrier, Cummins KT450 (Carrier Engine), Cummins V555-C230 (Superstructure Engine)	182,175	57,437	124,738	82 634	26 053	56 581
*Remove std. 18,300 lbs. (8301kgs) counterweight	-18,300	+9,250	-27,550	-8 301	+4 196	-12 497
125 ton (113.47mt), 6 sheave hook block	+2,737	+4,770	-2,033	+1 242	+2 164	-921
Remove standard auxiliary boom head	-245	-488	+243	-111	-221	+110
Substitute model 44 free fall main hoist with 900 ft. (274.32m) of ¾ in. (22mm) rope	+270	-103	+373	+122	-47	+169
**Substitute 20,000 lbs. (9072kgs) counterweight and remove std. model 32S-1726A auxiliary hoist with rope	-1,215	+642	-1,857	-551	+291	-842
Substitute GM8V-92T engine (carrier)	-1,105	-1,233	+128	-501	-559	+58
Substitute CAT3408T engine (carrier)	-300	-334	+34	-136	-152	+15
Substitute GM6V-53N engine (superstructure)	-170	-52	-118	-77	-24	-54
Substitute CAT3208 engine (superstructure)	-410	-125	-285	-186	-57	-129
Remove 32 ft. (9.75m) swingaway extension	-1,550	-1,730	+180	-703	-785	+82
Remove 46-173 ft. (14.02-52.73m) boom assembly	-41,881	-33,506	-8,375	-18 997	-15 189	-3 799
Remove std. main hoist with rope	-3,878	+1,474	-5,352	-1 759	+669	-2 428
Remove (2) front outrigger beams & jacks	-7,626	-4,491	-3,135	-3 459	-2 037	-1 422
Remove (2) rear outrigger beams & jacks	-7,626	+3,945	-11,571	-3 459	+1 789	-5 249

*Use 18,300 lbs. (8301kgs) counterweight with standard model 32S-1726A auxiliary hoist.

**Use 20,000 lbs. (9072kgs) counterweight without auxiliary hoist.

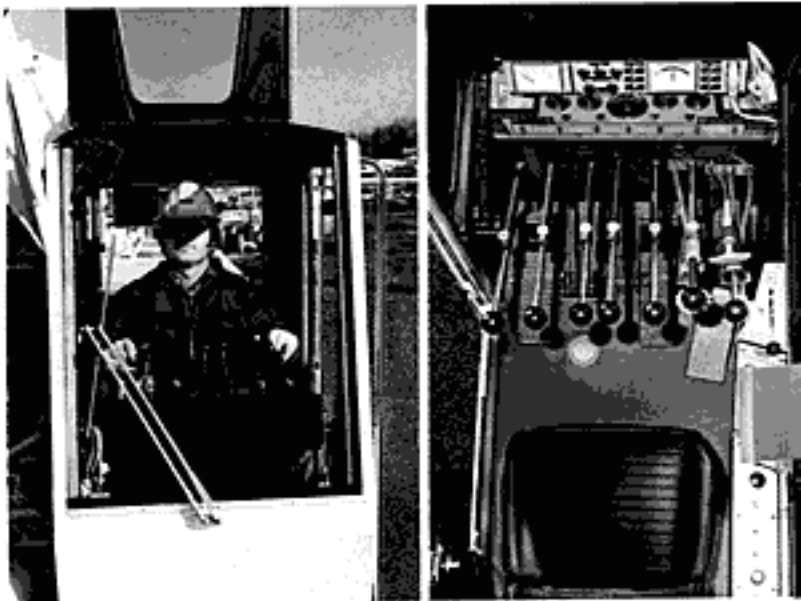
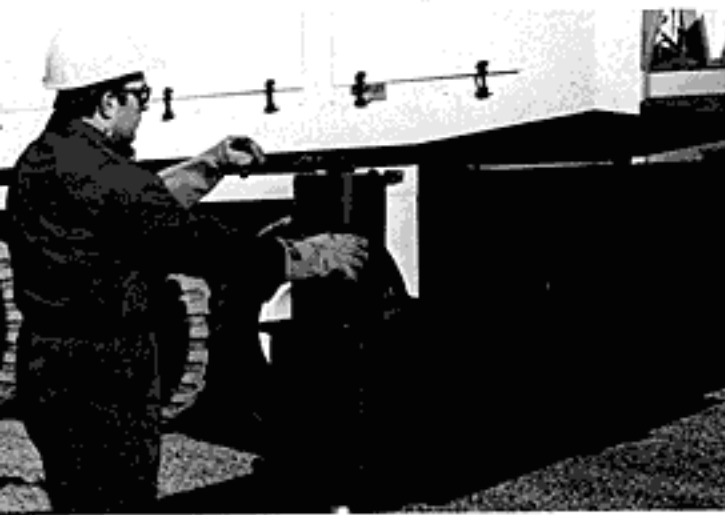
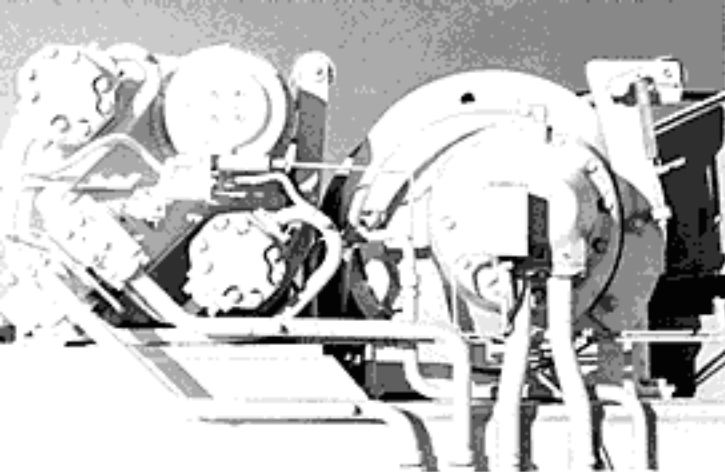

FEATURES

HOISTS: The main hoist, Gearmatic Model 44 and the auxiliary hoist, Grove Model 32S-1726A[†] are both two speed hoists providing both high line pull and speed ranges. Drive is planetary reduction with integral automatic brake.

GROVE EXTENDIBLE COUNTERWEIGHT: is hydraulically extended to working position to provide improved capacities with a minimum of weight. Power installed and removed, it is also equipped with a travel lock.

UNOBSTRUCTED VIEW OF LOAD - When the tinted skylight is raised and windshield removed there is nothing to interfere with visibility.

OPERATOR CONVENIENCE is another feature of the all-steel acoustically treated cab. Full-length control levers are adjustable and combination hand and foot controls are provided for swing, boom elevation and throttle. Other features include sliding door, laminated safety glass, electronic boom angle indicator and controls and gauges for the load moment and anti-two block system.

THE LOAD MOMENT AND ANTI-TWO BLOCK SYSTEM measures critical operational factors relative to rated capacity and gives the operator a continuous visual display of conditions for the load.

An easy-to-read gauge indicates the approach of an overload or two-block condition and should overload or two-block occur, an audio-visual



warning alerts the operator; the Grove "control lever lockout system" returns the control levers to neutral and permits the use of only those crane functions that will correct the condition.

FIVE STABILIZING JACKS PROVIDE 360° LIFTING CAPABILITY - Double box two-stage telescoping beam outriggers extend to 29' (8.83m) and a fifth vertical jack mounted to the front frame provide an extremely stable lifting base for 360° operation. All vertical jacks are equipped with integral holding valves. The four outrigger jacks are also equipped with Grove Spin-locks[†] to provide positive locks in any position.

[†]The Grove Trapezoidal Boom, Two Speed Hoist, Extendible Counterweight and Vertical Jack Lock are patented Grove features.

DIMENSIONS

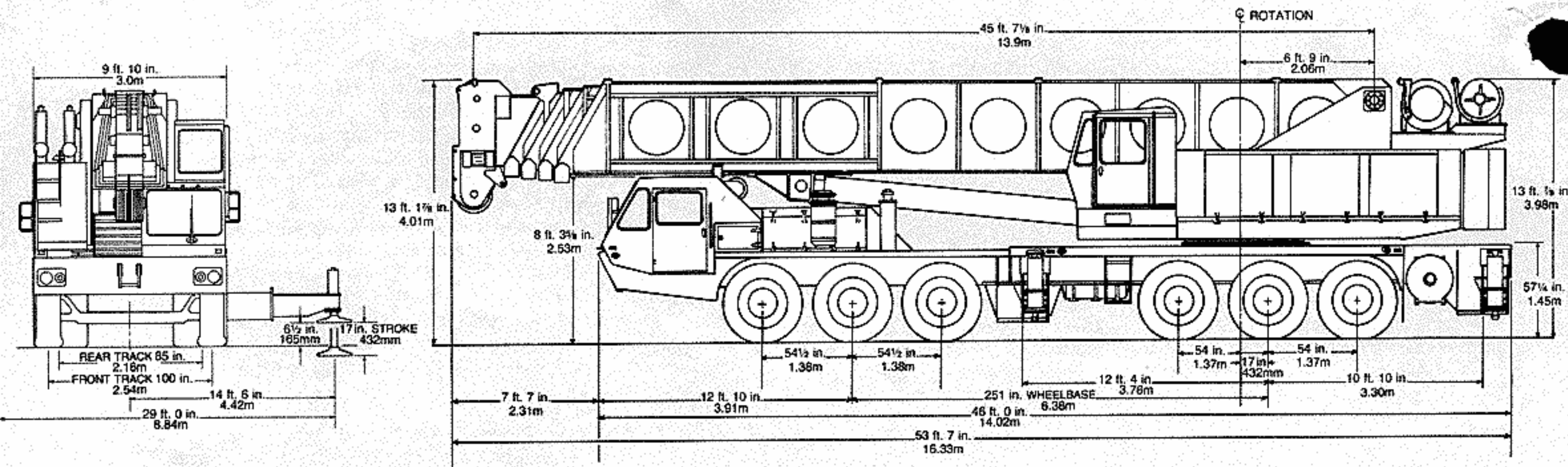

TURNING RADIUS 51 ft. (15.54m)
 GROUND CLEARANCE 11 in. (with float removed) (279mm)
 TAIL SWING 13 ft. 2 3/4 in. (Counterweight in travel position) (4.03m)
 TAIL SWING 16 ft. 2 3/4 in. (Counterweight in working position) (4.95m)

Meets requirements of P.C.S.A. Standard No. 2

Constant improvement and engineering progress make it necessary that we reserve the right to make specifications, equipment, and price changes without notice.

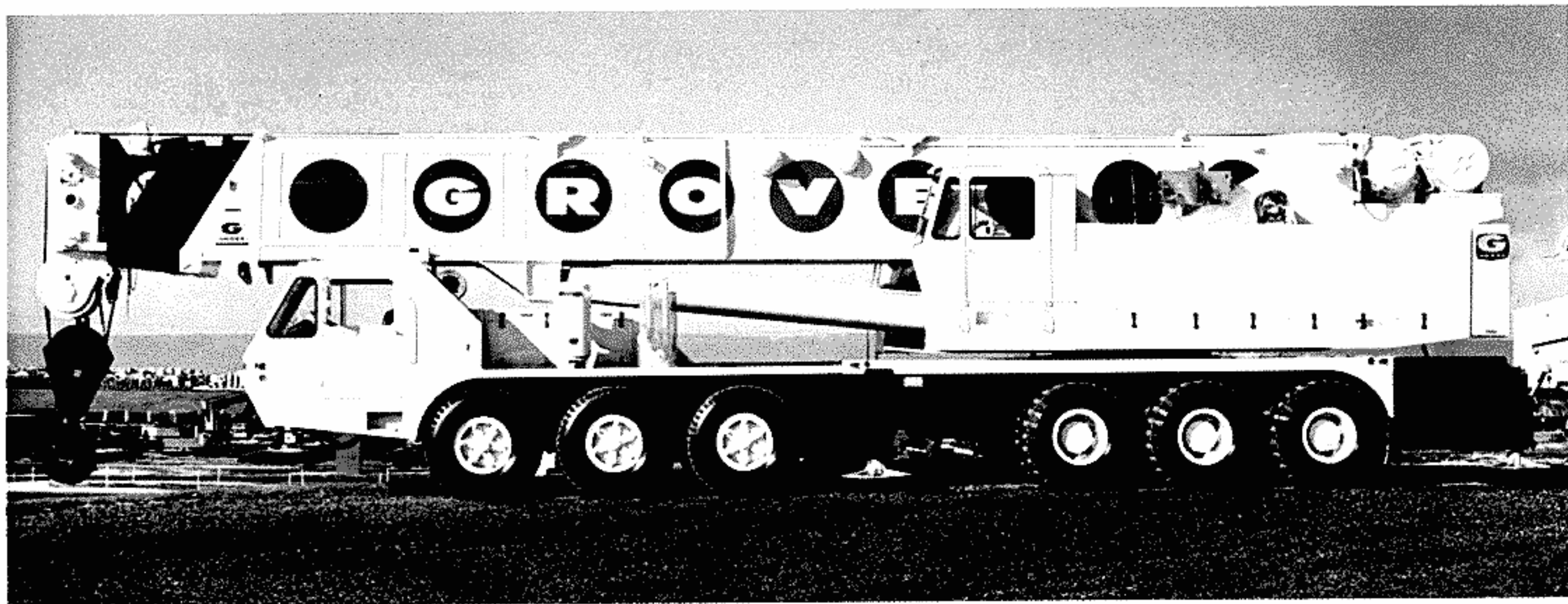

THE GROVE CARRIER The Grove designed diesel powered carrier is manufactured by Grove to match the particular requirements of the TM1275 crane and its long boom capability. The all-welded box-beam design steel frame in combination with five point outrigger configuration provides a stable lifting base for 360° lifting capability. The two man acoustically treated cab can be equipped with air conditioning.



HYDRAULIC CRANES

GROVE MANUFACTURING CO.

Division of Walter Kidde & Company, Inc.
 SHADY GROVE, PA. 17256 USA