

TW1150

SPECIFICATIONS

Meets requirements of P.C.S.A. Standard No. 2



GROVE MANUFACTURING COMPANY

Division of Walter Kidde & Company, Inc.

KIDDE

SHADY GROVE, PA 17256

CARRIER SPECIFICATIONS

OUTRIGGERS – Hydraulic double box 2-stage telescoping beam outriggers, integral welded boxes, removable beams, vertical jack cylinders with integral holding valves and 30½ in. (775mm) dia. steel floats. Beams extend to 27 ft. (8230mm) centerline to centerline and retract to 9 ft. 10 in. (3.0m) overall width. Mechanical spin locks on each vertical jack to secure outriggers at any level. Controls and sight leveling bubble located in superstructure cab and each side of carrier frame. Powered by superstructure engine.

FRONT END STABILIZER – A fifth hydraulic vertical outrigger jack cylinder with integral holding valve is mounted to the front frame section of the chassis to permit 360° lifting capabilities. 24 in. (610mm) dia. steel float easily removed for highway travel. Individual controls for fifth outrigger cylinder conveniently located in superstructure cab and each side of carrier frame.

FRAME – High-strength steel, all-welded construction of box-type design with integral welded outrigger boxes.

STEERING GEAR – Ross cam and lever type with Garrison hydraulic power assist.

CLUTCH – Lipe Rollway 14 in. (356mm) two plate dry disc.

TRANSMISSION – Fuller Roadranger (RTO 9509A) 9-speeds forward, 2 reverse, with Fuller AT1202 2-speed auxiliary.

UNIVERSAL JOINTS – Needle bearing type.

AXLES – Front: (3) Rockwell tubular steering FL 951, 100 in. (2540mm) track, 66,000 lb. (29 937kg) capacity.

Rear: (3) Rockwell EPRG 1356 planetary drive with inter-axle differential; 85 in. (2159mm) track, 110,000 lb. (49 896kg) capacity.

SUSPENSION – Front: Reyco 21B spring-mounted tridem, 66,000 lb. (29 938kg) capacity. Rear: Hendrickson tri-axle equalizing beam with solid steel saddles 110,000 lb. (49 896kg) capacity.

FUEL TANK – Single 100 gal. (379 liters) capacity mounted on right side of frame.

TIRES – Michelin 14:00x20-22 ply rated (G-20X) radial tube-type, front and rear.

TIRE INFLATION KIT – Quick connect air outlet located at midpoint on either side of carrier. Includes dual foot air chuck and 25 ft. (7.6m) coiled nylon tubing.

WHEELS – Steel spoke 10 in. x 20 in. (254mm x 508mm).

BRAKES – Full air on all wheels. Front: 15 in. x 6 in. (381mm x 152mm). Rear: 16½ in. x 7 in. (491mm x 178mm). Total lining area: 2508 sq. in. (16 181cm²). Air dryer provided to preclude system damaging moisture accumulation.

PARKING BRAKE – Maxi-type, spring set emergency chambers on all rear axles with emergency release kit.

ELECTRICAL SYSTEM – 12-volt lighting, 24-volt starting. Federal safety standard lights and reflectors.

CAB – Two-man low profile design, all steel with acoustical treatment, tinted tempered safety glass throughout (front windshield is tinted laminated); windshield washer and electric wiper, door and window locks. Bostrom “T” bar driver’s seat and Bostrom companion seat, seat belts, heater, (air conditioning available), defroster fan, dual West Coast mirrors, domelight, dashlight, electric horn, traffic hazard warning switch (four-way flasher), complete instrumentation and driving controls, sliding right side and roll-down left side glass for ventilation; 2 3/4 (1.25 kg) dry type fire extinguisher.

CAB INSTRUMENTATION – Engine oil pressure gauge, speedometer, air pressure gauge, fuel level gauge, engine water temperature gauge, voltmeter, tachometer, low air pressure audio-visual warning device, high beam indicator, ignition-on indicator.

MISCELLANEOUS STANDARD EQUIPMENT – Wheel nut wrench and handle, channel type front bumper, two front and rear towing loops, front and rear fenders, ether injection starting aid (less canister), mud flaps, tool storage compartment, front deck hook-block storage trough.

SPEED AND GRADEABILITY

| Engine | Speed Ranges at Maximum Governed RPM | | % of Gradeability at Maximum Torque | |
|------------------|--------------------------------------|----------------|-------------------------------------|---------------|
| | Aux. Low | Aux. Direct | Aux. Low | Aux. Direct |
| GM8V-71T | 1.81-21.45 MPH | 3.69-43.76 MPH | 42.09 to 2.18% | 19.87 to .30% |
| *Cummins NTC 350 | (2.9-34.3km/h) | (5.9-70km/h) | 43.67 to 2.31% | 22.08 to .49% |

NOTE: Performance based on 158,000 lb. (71 100kg) GVW and standard SAE engine rating conditions using standard tires, transmission and axles. Performance data may vary plus or minus 10% due to variations in engine performance and vehicle weights. Maximum speed restricted to 40 MPH (64.4km/h) due to tire limitations.

CARRIER ENGINE SPECIFICATIONS

| | | |
|-------------------|---|--------------------------------------|
| MAKE & MODEL | GM8V-71T | * Cummins NTC350 |
| TYPE | 8 Cylinder O.H.V. | 6 Cylinder O.H.V. |
| BORE & STROKE | 4.25 in. x 5 in. (108mm x 127mm) | 5.5 in. x 6 in. (140mm x 152mm) |
| DISPLACEMENT | 568 cu. in. (9310cm ³) | 855 cu. in. (14 013cm ³) |
| HORSEPOWER (NET) | 315 @ 2100 RPM | 304 @ 2100 RPM |
| GOVERNED RPM | 2100 | 2100 |
| TORQUE (NET) | 870 lb. ft. (120kg.m) @ 1600 RPM | 903 lb. ft. (125kg.m) @ 1500 RPM |
| ELECTRICAL SYSTEM | 12-volt neg. ground | 12-volt neg. ground |
| COMBUSTION SYSTEM | 2-cycle turbocharged | 4-cycle turbocharged |
| COOLING SYSTEM | Liquid | Liquid |
| FUEL CAPACITY | 100 gal. (379 liters) | 100 gal. (379 liters) |
| ALTERNATOR | 90 Amp. 12-volt | 90 Amp. 12-volt |
| BATTERY | • (4) 475 CCA @ 0°F | • (4) 475 CCA @ 0°F |
| AIR CLEANER | Dry type | Dry type |
| AIR COMPRESSOR | 24 CFM (11 L/sec) | 30 CFM (14 L/sec) |
| HOURMETER | Yes (10,000 Hr.) | Yes (10,000 Hr.) |
| STARTING SYSTEM | 24-volt • CCA = Cold cranking amperage | 24-volt |

Note: GM and Cummins engines equipped with Jacobs engine brake.

*Denotes optional equipment.

AXLE WEIGHT DISTRIBUTION CHART

| ITEM | POUNDS | | | KILOGRAMS | | |
|---|---------|---------|---------|-----------|---------|--------|
| | GROSS | FRONT | REAR | GROSS | FRONT | REAR |
| Basic standard machine to include 44 ft. - 140 ft. (13.4m - 42.7m) boom plus 32 ft. (9.8m) "Swingaway" extension. Gearmatic Model 44 main hoist with 800 ft. of 1 in. (243.8m of 25.4mm) dia. wire rope. Grove Model HO30B-26 auxiliary hoist with 850 ft. of ¾ in. (259.1m of 19mm) dia. rope; GM8V71T carrier engine, GM6V53N superstructure engine; 11,750 lb. (5280kg) counterweight. | 157,440 | 46,746 | 110,695 | 71,415 | 21,204 | 50,211 |
| Remove: standard 32 ft. (9.8m) "Swingaway" extension | -1,880 | -2,156 | +276 | -853 | -977 | +124 |
| Remove: standard **11,750 lb. (5280kg) counterweight | -11,750 | +5,477 | -17,227 | -5329 | +2484 | -7813 |
| Remove: standard Model 44 main hoist with rope | -4,577 | +1,568 | -6,145 | -2076 | +711 | -2787 |
| Remove: 44 ft. - 140 ft. (13.4m - 42.7m) boom and lift cylinders | -40,460 | -31,121 | -9,339 | -18 352 | -14 116 | -4236 |
| Remove: standard Grove Model auxiliary hoist and rope | -3,054 | +1,436 | -4,490 | -1385 | +651 | -2036 |
| Remove: (2) front outrigger beams and jacks | -7,180 | -4,234 | -2,946 | -3257 | -1920 | -1336 |
| Remove: (2) rear outrigger beams and jacks | -7,180 | +3,261 | -10,441 | -3257 | +1479 | -4736 |
| Add: 125 ton (113.5mt) hookblock stowed | +2,890 | +4,439 | -1,549 | +1311 | +2013 | -703 |
| Add: 30 ton (27.2mt) hookblock stowed | +1,022 | +1,570 | -548 | +463 | +712 | -249 |
| Add: auxiliary boom head | +253 | +504 | -251 | +114 | +228 | -114 |
| Substitute: ***14,000 lb. (6300kg) counterweight & remove standard Model H030B-26 auxiliary hoist | -804 | +387 | -1,191 | -365 | +175 | -540 |
| Substitute: Model 44 controlled free fall main hoist | +200 | -69 | +269 | +91 | -31 | +122 |
| Substitute: Cummins diesel engines | +570 | +503 | +67 | +258 | +228 | +30 |

**Use 11,750 lb. (5288kg) counterweight with standard HO30B-26 auxiliary hoist.

***Use 14,000 lb. (6300kg) counterweight without auxiliary hoist.

DIMENSIONS

TURNING RADIUS 51 ft. (15 545)

GROUND CLEARANCE 10¼ in. (with float removed) (260)

TAIL SWING 13 ft. 1¾ in. (counterweight in travel position) (4005)

TAIL SWING 16 ft. 1¼ in. (counterweight in working position) (4910)

NOTE: Dimensions shown in parentheses are millimeters (mm)

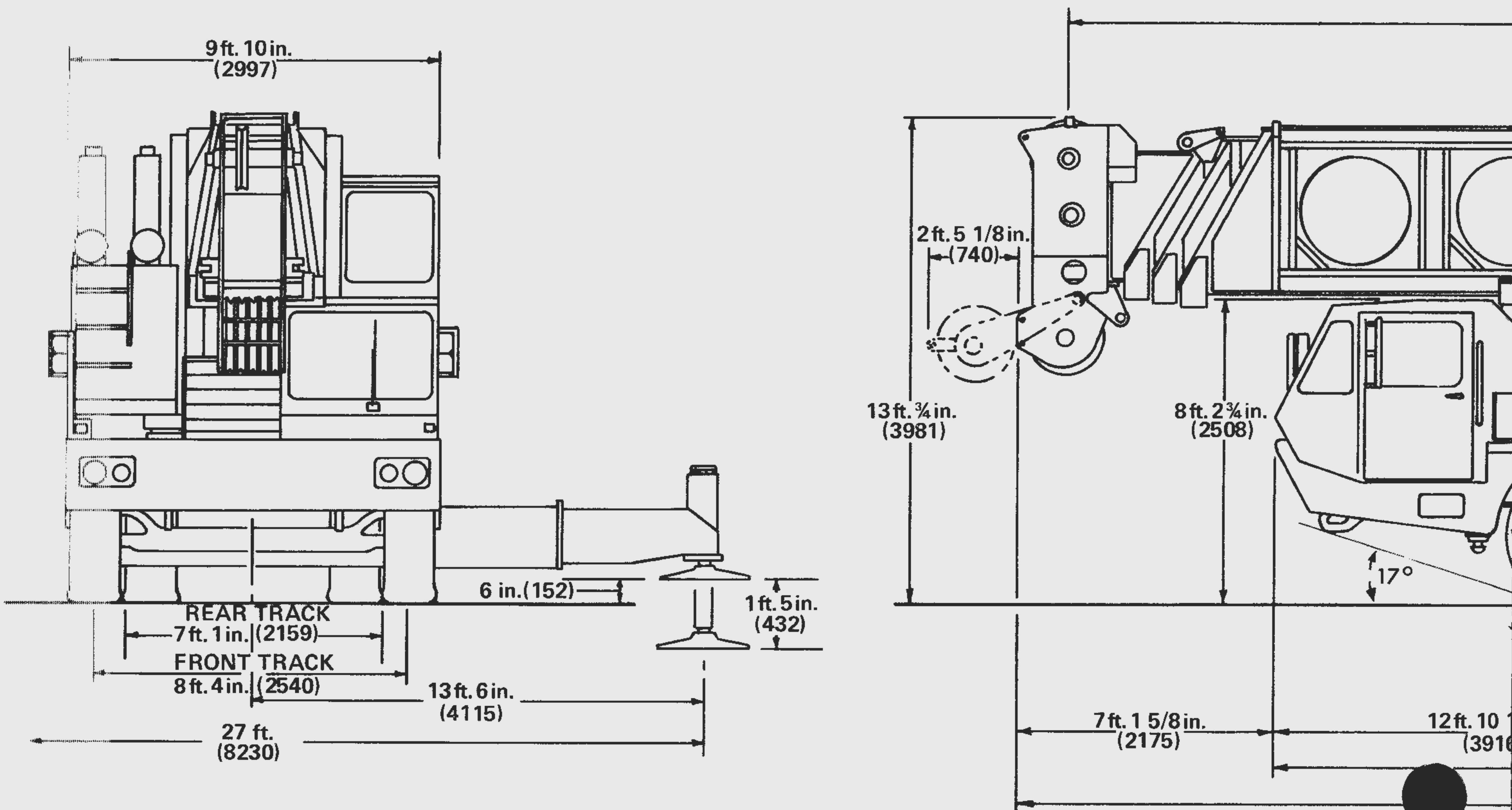

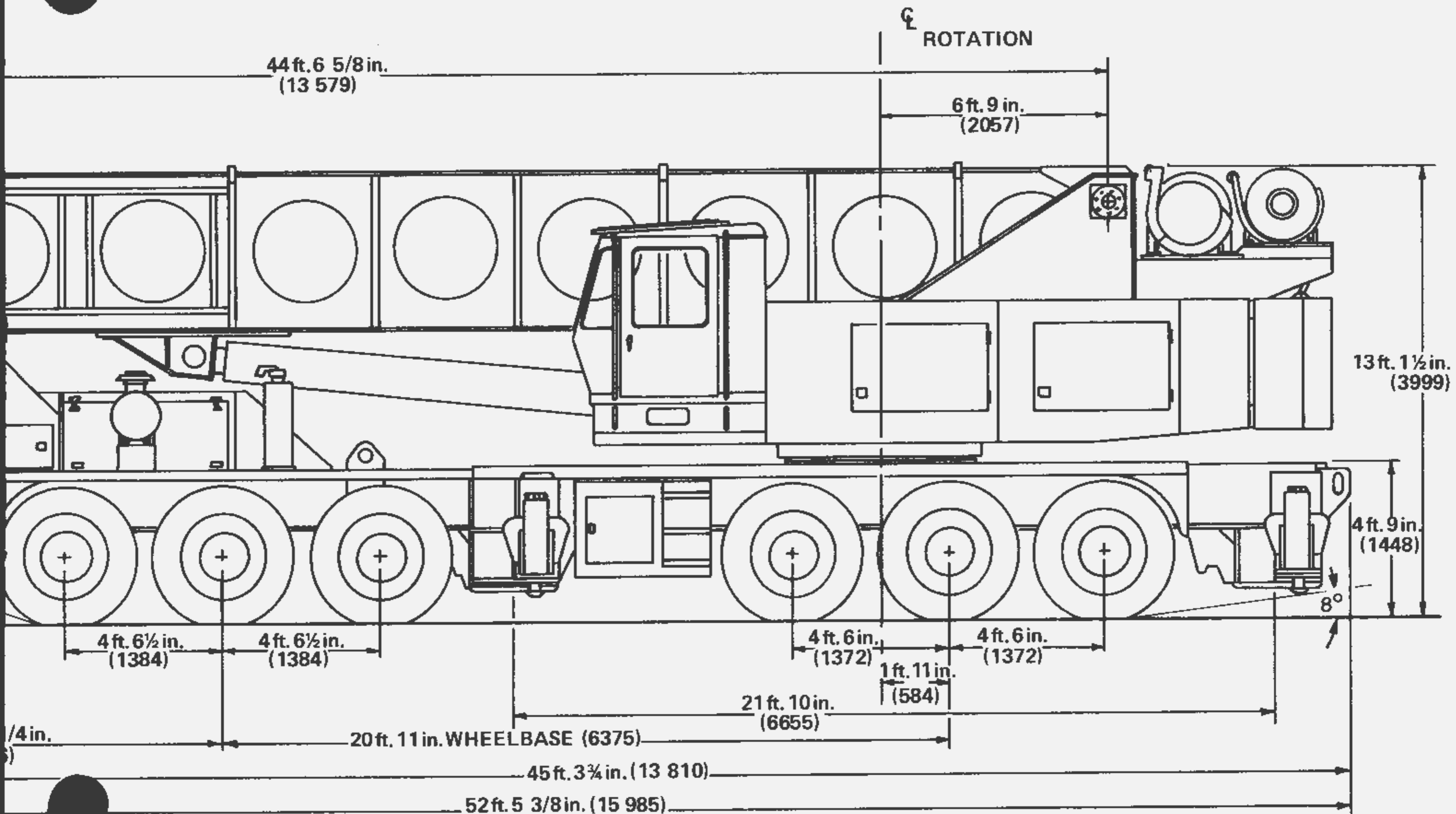



SUPERSTRUCTURE SPECIFICATIONS

BOOM – 44 ft. – 172 ft. (13.4m – 52.4m) total length; 4-section trapezoidal main boom consisting of base section, 2 full power and 1 power pinned sections to 140 ft. (42.7m) and a 32 ft. (9.8m) "Swingaway" lattice extension (2° offset). Integral holding valves on each telescoping cylinder. Boom telescope sections individually controlled and supported on graphite impregnated Nylatron wear pads.

BOOM NOSE – Six 22 in. (559mm) tread dia. sheaves mounted on heavy-duty tapered roller bearings. Removable pin-type rope guards allow easy reeving. Rope dead ends on each side of boom nose.

***AUXILIARY BOOM NOSE** – Single 22 in. (559mm) tread dia. sheave mounted to the main boom nose (removable) for single line work. Removable pin-type rope guards.

BOOM ELEVATION – Dual double-acting 12" (300mm) bore hydraulic cylinders with integral holding valves. Elevation from -3° to 80°. Combination controls provided for hand or foot operation.

***LOAD MOMENT AND ANTI-TWO BLOCK SYSTEM (KRUEGER)** – Audio-visual warning in combination with Grove control lever lockout of; hoist-up, telescope-out and boom-down crane functions. Krueger LMI control console provides operator with selective display of boom length, radius and angle.

***POWER LUFFING JIB** – 14 ft. (4.3m) lattice base section combines with standard 32 ft. (9.8m) "Swingaway" boom extension to make basic 46 ft. (14m) cable suspended power luffing jib. Additional 14 ft. (4.3m) pinned inserts available to make 60 ft. (18.3m), 74 ft. (22.6m) and 88 ft. (26.8m) jib lengths. Luffing power is supplied from main hoist with 5° to 45° offset capability. Mast, pendant lines, attaching hardware and backstops included in the makeup of all jib lengths.

CAB – Full vision, all steel, fully enclosed with acoustical treatment, tinted safety glass throughout, hinged skylight, sliding left side door, sliding right side glass, door and window locks; fully-adjustable operator's seat with headrest; 12,000-BTU hot water heater; electric windshield wiper and defroster fan, swing horn, dome-light, dashlight; complete engine instrumentation and crane operating controls with adjustable full-length control levers, combination hand/foot controls for swing, boom elevation and engine throttle; outrigger control panel, sight leveling bubble; electronic hoist drum rotation indicators for main and auxiliary hoists; Krueger LMI control console provides operator with selective display of boom length, radius and boom/jib angle; 2 3/4 lb. (1.3 kg) dry type fire extinguisher.

CAB INSTRUMENTATION – Engine oil pressure gauge, engine water temperature gauge, voltmeter, tachometer, fuel level gauge, ignition-on indicator light, hydraulic oil bypass indicator light, main-hoist-disengaged indicator light; Kruger control panel.

SWING – Roller bearing swing circle, 360° continuous rotation. Rockwell planetary "glide swing" with foot actuated clutch pack swing brake for precision stopping. Electric/hydraulic swing parking brake and hand operated 360° positive swing lock controlled from operator's cab. Swing speed 1.9 RPM.

OUTRIGGER CONTROLS – Independently controlled in-out-up and down, from superstructure cab and either side of carrier frame. Required sequence control arrangement eliminates unintentional outrigger actuation. To insure proper outrigger retraction sequence, front jack cylinder retracts first when master switch is activated from any control station.

COUNTERWEIGHT – 11,750 lb. (5330kg) turntable mounted, power installed and removed, hydraulically extended to working position and retracted to stowed or travel position. (14,000 lb. (6350kg) counterweight used without auxiliary hoist).

HYDRAULIC SYSTEM:

RESERVOIR – 315 gal. (1192 liters), all-steel welded construction with integral baffles, clean-out access and exterior oil sight level gauge.

FILTER – Return line type, full flow with by-pass protection and filter by-pass indicator, replaceable cartridge. 25 micron rating.

PUMPS – Six section, gear type driven by superstructure engine. Manual pump disconnect located on lower right side of superstructure. Combined capacity 349 GPM (1321 LPM) @ 2400 RPM.

CONTROL VALVES – Precision four way, double acting with integral load check, main and circuit relief valves. Six individual valve banks permit simultaneous independent control of five crane functions. Maximum system operating pressure 2500 PSI (176kg/cm²).

OIL COOLER – Full flow, fin and tube, oil to air.

POWER DISTRIBUTION – (Auxiliary hoist boost, inner mid telescope) (Swing) (Lift) (Lift boost, main hoist boost) (Outer mid telescope, auxiliary hoist) (Main hoist).

**Denotes optional equipment*

HOIST SPECIFICATIONS

| | | | |
|---|--|---|--|
| DESCRIPTION: Two speed and pull, planetary drive, power up and down with integral automatic brake. | | DESCRIPTION: Series parallel circuitry and two motors provide both high line pull and speed ranges. Power up and down, equal speed, planetary reduction with integral automatic brake. | |
| HOIST DATA | MAIN HOIST Gearmatic Model 44 (see note below) | | *AUXILIARY HOIST Grove Model H030B-26 |
| Drum Dimensions | 20 in. dia. (508mm) 26 in. length (660mm) 30 in. dia. flange (762mm) | | 16 in. dia. (406mm) 26 in. length (660mm) 24 in. dia. flange (610mm) |
| Performance: Max. Single Line Speed Max. Single Line Pull | Hi-Speed Range 360 FPM (109.7m/min) 14,000 lb. (6350kg) | Lo-Speed Range 180 FPM (54.9m/min) 28,000 lb. (12 700kg) | Hi-Speed Range 575 FPM (175.3m/min) 8,400 lb. (3810kg) |
| Drum Rope Capacity | **800 ft. of 1 in. dia. rope (244m of 25.4mm dia. rope) | | **1060 ft. of ¾ in. dia. rope (323.1m of 19mm) |
| Permissible Single Line Rope Pull (5:1 safety factor) | 1 in. (25mm) 18x19 class EIPS, WSC 20,400 lb. (9253kg) | | ¾ in. (19mm) 18x19 class EIPS, WSC 11,500 lb. (5216kg) |

**6th layer of rope not recommended for hoisting operations.

NOTE: The Gearmatic Model 44 hoist with controlled free fall is available as the optional main hoist with the same specifications as shown above.

SUPERSTRUCTURE ENGINE SPECIFICATIONS

| | | | |
|--------------------------------|---------------------------------------|--|--------------------------------------|
| MAKE & MODEL | GM6V-53N | * Cummins V555-C230 | *Caterpillar 3208 |
| TYPE | 6 Cylinder O.H.V. | 8 Cylinder O.H.V. | 8 Cylinder O.H.V. |
| BORE & STROKE | 3.875 in. x 4.5 in. (98mm x 114mm) | 4.625 in. x 4.125 in. (117mm x 105mm) | 4.5 in. x 5.0 in. (114mm x 127mm) |
| DISPLACEMENT | 318 cu. in. (5212cm ³) | 555 cu. in. (9096cm ³) | 636 cu. in. (10 424cm ³) |
| HORSEPOWER (NET) | 196 @ 2800 RPM | 199 @ 3000 RPM | 199 @ 2800 RPM |
| GOVERNED RPM | 2800 | 3000 | 2800 |
| TORQUE (NET) | 427 lb. ft. (59kg.m) @ 1500 RPM | 394 lb. ft. (54kg.m) @ 1800 RPM | 446 lb. ft. (62kg.m) @ 1400 RPM |
| ELECTRICAL SYSTEM | 12-volt neg. ground | 12-volt neg. ground | 12-volt neg. ground |
| COMBUSTION SYSTEM | 2-cycle w/blower | 4-cycle naturally aspirated | 4-cycle naturally aspirated |
| COOLING SYSTEM | Liquid | Liquid | Liquid |
| FUEL CAPACITY | 60 gal. (227 liters) | 60 gal. (227 liters) | 60 gal. (227 liters) |
| ALTERNATOR | 90 Amp. 12-volt | 90 Amp. 12-volt | 90 Amp. 12-volt |
| BATTERY | • (4) 475 CCA @ 0°F | • (4) 475 CCA @ 0°F | • (4) 475 CCA @ 0°F |
| AIR CLEANER | Dry type | Dry type | Dry type |
| HOURMETER | Yes (10,000 Hr.) | Yes (10,000 Hr.) | Yes (10,000 Hr.) |
| STARTING SYSTEM | 24-Volt | 24-volt | 24-volt |
| • CCA = Cold cranking amperage | | | |

NOTE: Performance data will vary plus or minus 10% due to variations in engine performance and operating conditions.

*Denotes optional equipment.

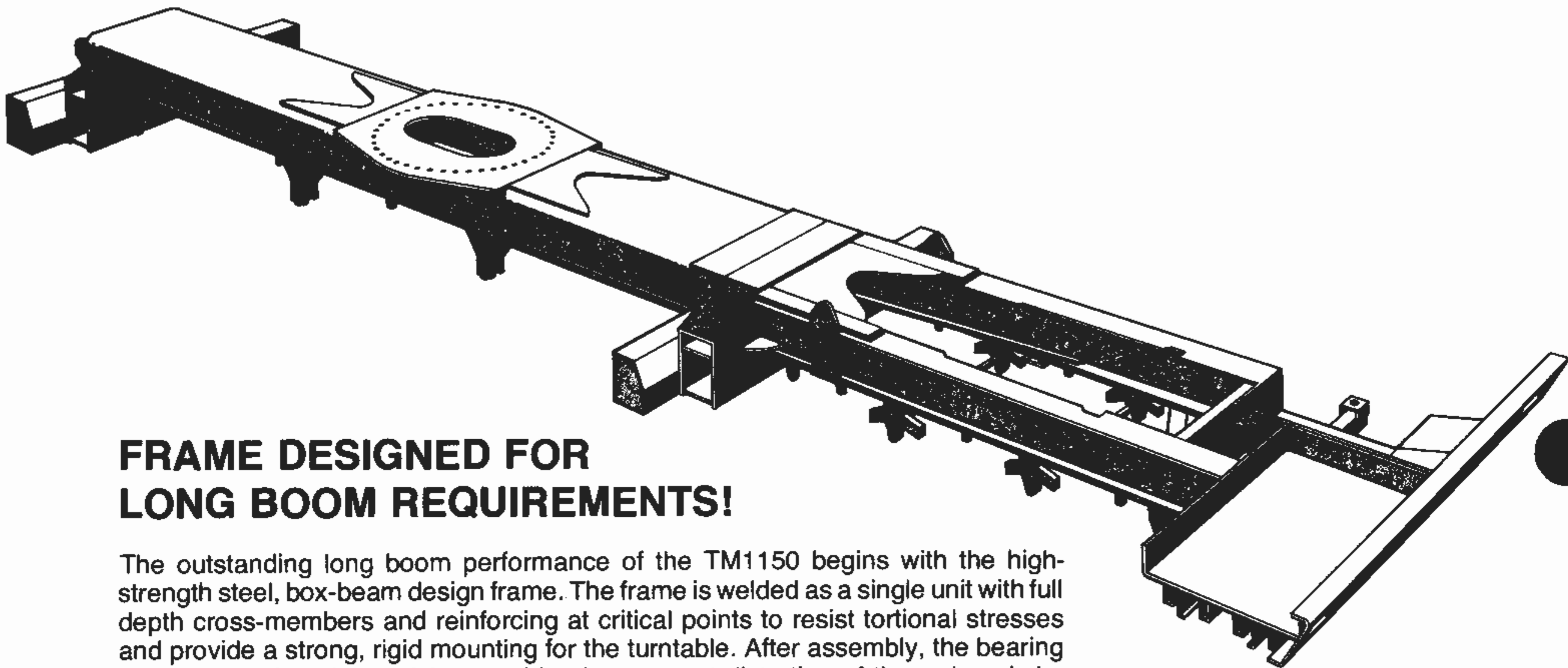

FRAME DESIGNED FOR LONG BOOM REQUIREMENTS!

The outstanding long boom performance of the TM1150 begins with the high-strength steel, box-beam design frame. The frame is welded as a single unit with full depth cross-members and reinforcing at critical points to resist torsional stresses and provide a strong, rigid mounting for the turntable. After assembly, the bearing mounting surface is precision machined to prevent distortion of the swing circle. Outrigger boxes are integral with the frame to provide additional strength and stability, especially in long boom operations.

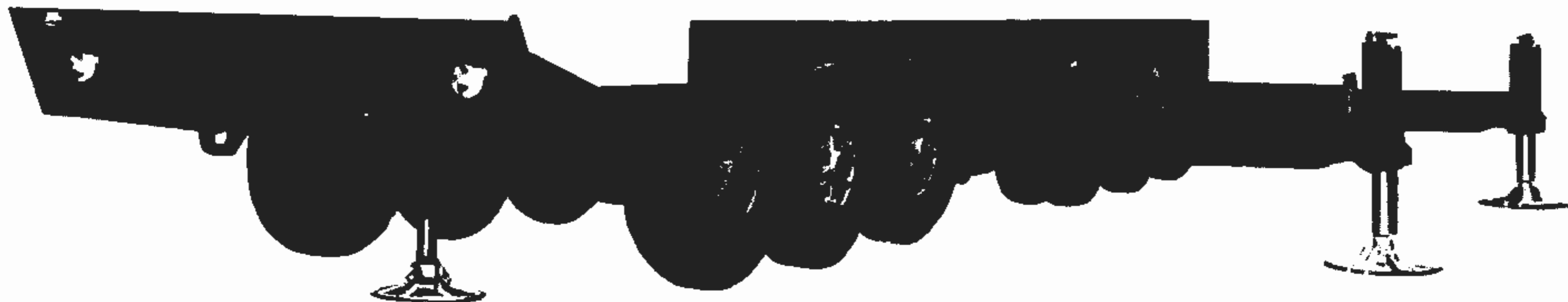

WIDE OUTRIGGER STANCE . . . QUICK-SET-UP . . . 360 DEGREE OPERATION!

Hydraulic double box two-stage telescoping beam outriggers extend to 27' (8.2m), providing the stability for high capacity lifts and long boom operation. Beams and jacks are independently controlled for quick set-up. Controls are located on either side of the chassis and in the superstructure cab, with a leveling bubble at each location. A fifth vertical jack, integral with forward frame members, provides the stability for 360 degree lifts and is standard equipment. All vertical jacks are equipped with holding valves, and those mounted on the beams are also equipped with the Grove Spin-lock† for positive locking of the jacks at any level.

† Patented Grove feature

25,000 lbs. @ 180' TIP HEIGHT
(11 340kg) (54.9m)

45,000 lbs. @ 149' TIP HEIGHT
(20 412kg) (45.4m)

66,800 lbs. @ 115' TIP HEIGHT
(30 300kg) (35m)

THE GROVE TRAPEZOIDAL BOOM[†]

The proven design for long reach high capacity performance!

232' tip height with 88' jib
jib power luffs to 45°
(70.7m with 26.8m jib)

POWER LUFFING JIB

Grove is the first U.S. manufacturer of hydraulic telescoping boom cranes to offer this feature. The jib consists of four, 14 foot (4.3m) inserts which are used in conjunction with the 32 ft. (9.8m) "Swingaway". The inserts may be used individually or in combination to provide jib lengths of 46', 60', 74' and 88' (14m, 18.3m, 22.6m and 26.8m).

Any jib length described above may be power-offset from 5° to 45° from the line of the main boom. Luffing action is controlled by the main hoist cable. Load placement with the power luffing jib is smooth and accurate due to the more precise control possible with the infinitely variable speed of the main hoist. The luffing action is ideal for close quarter full boom operations.

The Grove Trapezoidal Boom is the proven performer among high capacity long reach booms. More crane users have placed their trust in the Grove design than in any other . . . more than 95% of the 80-ton and over cranes sold in the U.S. are Groves. It's the boom that gives the user more reach, more long boom capacity and greater profitability for his investment.

The 4-section boom on the 1150 provides a tip height of 180' (54.9m) with the easily erected "Swingaway" in place. Boom sections are individually extended and retracted, riding on graphite impregnated nylatron wear pads. Dual elevation cylinders provide elevation from -3° to 80°. Elevation and telescoping cylinders are equipped with integral holding valves.

[†]Patented Grove feature

