

RUGGED • QUICK • DEPENDABLE

RT 755

**GE
LOWE**

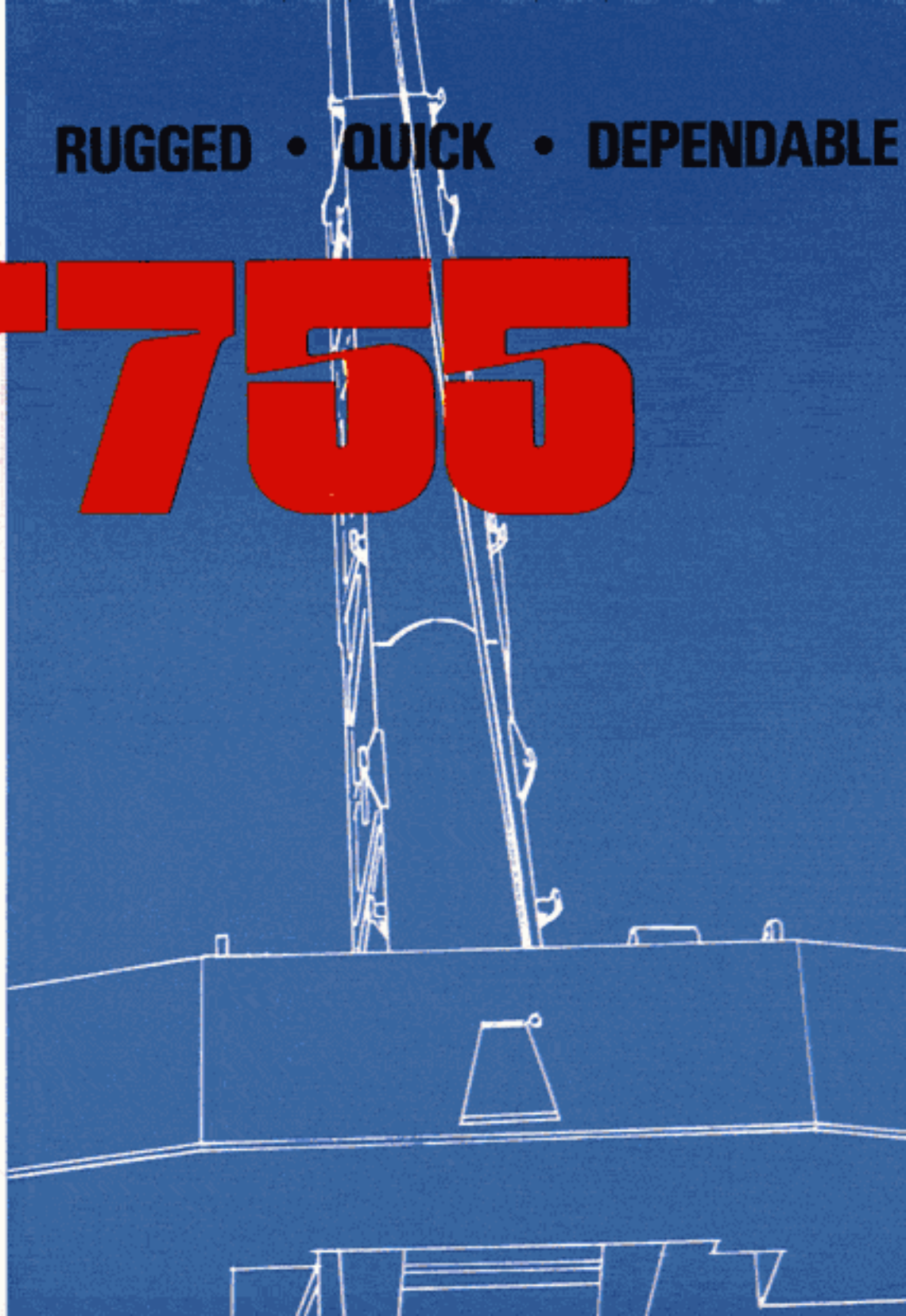

SUPERSTRUCTURE SPECIFICATIONS

BOOM — 34 ft. - 116 ft. (10.4 m - 35.4 m) total length, 3 section trapezoidal main boom consisting of base section and two full power sections to 84 ft. (25.6 m) and a 32 ft. (9.8 m) "swingaway" lattice boom extension to 116 ft. (35.4 m).

*35 ft. - 142 ft. (10.6 m-43.2 m) total length, 4-section trapezoidal main boom consisting of base section, two full power sections to 85 ft. (25.9 m), one power-pinned section to 110 ft. (33.5 m) and a 32 ft. (9.8 m) "swingaway" lattice boom extension to 142 ft. (43.2 m). Power is supplied by two 6 in. (152 mm) diameter bore 24 ft.-10-1/2 in. (7582) stroke, double-acting cylinders with pilot assist integral holding valves. Side adjustable wear pads prevent metal-to-metal contact of inner boom sections and permit ease of side boom alignment.

LATTICE BOOM EXTENSION — Standard 32 ft. (9.8m) rectangular, tubular lattice type "swingaway" boom extension stows alongside base boom section. Boom extension swings into position, attaches and is held to main boom nose by four corner pins. Single metallic 17.875 in. (454 mm) tread diameter sheave with removable pin type rope guard and rope dead-end.

***JIB** — 24 ft. (7.3 m) A-frame jib attaches to sheave shaft of 32 ft. (9.8 m) "swingaway" boom extension. Jib stows beneath "swingaway" alongside base boom section, or can be detached from the "swingaway" and held firmly in place on the base section when "swingaway" is used independently. Jib can be offset at 5°, 17° or 30°. Includes jib backstops, single rope self-equalizing suspension and removable pin-type rope guard. Jib has one 17.875 in. (454 mm) root diameter point sheave.

BOOM NOSE — Reinforced hi-strength steel construction. Four metallic load bearing sheaves, 17.875 in. (454 mm) diameter, mounted on heavy duty tapered roller bearings. Two metallic floating idler sheaves, 17.875 in. (454 mm) tread diameter mounted on anti-friction needle bearings. Removable pin-type rope guards for fast and easy reeving. Rope dead-ends on either side of boom nose. (Auxiliary boom nose is required to obtain 7 parts of line for certain international markets where 6:1 wire rope safety factor may be required.)

AUXILIARY BOOM NOSE — Removable. Single 17.875 in. (454 mm) metallic sheave, mounted to main boom nose for single part line work. Equipped with removable pin type rope guard.

BOOM ELEVATION — Dual 9 in. (229 mm) bore 109-5/16 in. (2.77 m) stroke, double acting hydraulic cylinders with integral holding valves. Elevation -4° to 76°. Combination controls for hand or foot operation.

SWING — Grove planetary speed reducer powered by a hydraulic high torque, low rpm orbit motor providing smooth/precise 360° continuous rotation. Equipped with Grove "glide swing", foot activated multiple disc swing brake for precision stopping. Electric/hydraulic swing park-

ing brake. *Hand operated 360° positive swing lock controlled from operator's cab. Externally driven sealed gear bearing. Precision machined mounting surface prevents distortion of swing circle bearing. Maximum swing speed is 2.6 rpm.

CAB — Turntable mounted on vibration and sound absorbing rubber grommets, full vision, all steel, fully enclosed, acoustically treated with tinted safety glass throughout. Removable front windshield and hinged skylight, sliding left side door and right side window for ventilation. Dash-mounted control levers, combination hand and foot controls for boom elevation and engine throttle, outrigger sight level bubble, electronic boom angle indicator with high and low angle presets and A/V warning, electric windshield wiper, air horn, door and window locks, domelight, dashlight, 2-3/4 lb. (1.25kg) dry type fire extinguisher, cab mounted worklights, 20,000 BTU diesel fuel heater, forced hot air defroster, boom elevation and swing warning system.

CONTROLS — Left of steering wheel are dash-mounted, hand-operated control levers for swing, boom telescope and rear steer; at right are control levers for boom elevation, *auxiliary hoist, main hoist and *free fall control. Foot operated controls include dynamic swing brake, boom elevation, service brake and engine throttle. Operator's right hand console includes transmission gear selection, high/low range selector, hand throttle, outrigger controls, sight level bubble, heater controls, console panel lights, engine start/stop. Additional dash-mounted controls include *electric manual oscillation lockout override, work-lights, master ignition and rear steer alignment indicator.

CAB INSTRUMENTATION — International gauges. Engine water temperature, fuel level, oil pressure, air pressure, tachometer, voltmeter. A/V warning for low air system pressure.

COUNTERWEIGHT — Removable, bolted to turntable mast, stationary. Weight dependent upon hoist configuration. (Refer to Axle Weight Distribution Chart.)

***LOAD MOMENT AND ANTI-TWO BLOCKING SYSTEM (KRUGER)** — Audio-visual warning in combination with Grove control lever lockout of: hoist-up, telescope-out and boom-down crane functions. Kruger LMI control console provides operator with selective display of boom length, radius and angle. *A separate anti-two blocking system can be obtained independent of the complete Kruger LMI, and is available with audio-visual warning only or audio-visual warning in combination with the Grove control lever lockout of: hoist-up, telescope-out and boom-down crane functions.

*Denotes optional equipment.

CHASSIS SPECIFICATIONS

MAIN FRAME — All welded parallel box beam construction with full depth longitudinals braced by cross members reinforced at critical points to resist torsional stresses and provide a strong, rigid lifting base. Precision machined bearing mounting surface prevents distortion of swing bearing. Front and rear combination lifting/towing and tie-down lugs are integral with main frame.

OUTRIGGERS — Front and rear hydraulic double-box integral with main frame; telescoping beams extend to 23 ft. (7.0 m) and retract to 10 ft 1 in. (3.1 m) by 3 in. (76 mm) diameter bore, 77-3/4 in (1.9 m) stroke double-acting cylinders. 20 in. (508 mm) stroke (21 in. [533 mm] with *spinlock), 6 in. (152 mm) diameter bore double-acting vertical jacks with integral check valves provide quick leveling on uneven terrain. Vertical jacks equipped with removable, stowable, lightweight, high strength 24 in. (610 mm) diameter steel floats. All outrigger controls located in operator's cab. Required sequence control arrangements eliminates unintentional outrigger actuation. In addition to standard integral holding valve and for added security, the exclusive Grove *spin-lock is offered which permits the outrigger vertical jack to be mechanically locked in any position throughout its stroke.

TRANSMISSION AND TORQUE CONVERTER — Remote-mounted full powershift transmission with 6 speeds forward and 6 speeds reverse with rear axle disconnect. Engine mounted torque converter, 1.82:1 stall ratio with PTO for hydraulic pumps.

SPEEDS — 6 forward and 6 reverse
(3 speeds - high range - 2-wheel drive)
(3 speeds - low range - 4-wheel drive)

AXLES — Front: planetary drive/steer type, mounted rigid to the frame. Total reduction ratio 26.1:1. Rear: planetary drive/steer type mounted to allow 0 in. to 10 in. (254 mm) oscillation for rough terrain negotiation. Total reduction ratio 26.1:1. No-spin rear axle.

HYDRAULIC OSCILLATION LOCKOUT — Automatic, full hydraulic on rear axle. Permits rear oscillation only with boom over front. Rear axle lockout assures a rigid lifting platform when lifting on-rubber over-the-side. *Manually activated electric override control is available.

STEERING — Front: power assist hydraulic; controlled by steering wheel. Dual steering cylinders. Rear: full hydraulic; tiller bar control. Dual steering cylinders. Independent front and rear steer control allows operator to choose mode of travel for optimum "on-the-move" maneuverability. Four modes of steering: independent front wheel steer, independent rear wheel steer, 4-wheel coordinated steer and 4-wheel crab steer.

SERVICE BRAKES — Full air on all four wheels. Size 20-1/4 in x 4 in. (514 mm x 102 mm) with a 36 sq. in. (232 cm²) chambers.

PARKING BRAKES — Spring set, air released emergency/parking brakes on both axles.

TIRES — 29.5 x 25-22 PR (E-3) earthmover type, tubeless.
*26.5 x 25-26 PR (E-3) earthmover type, tubeless.
*29.5 x 25-28 PR (E-3) earthmover type, tubeless.

***TOW WINCH** — Braden PD15 cab-controlled, tow winch (less rope and hook), front mounted. Single line pull 15,000 lbs. (6,804 kgs.); single line speed 58.9 FPM (17.9 m/min.). Drum rope storage capacity of 340 ft. (103.6 m) of 5/8 in diameter (16 mm) rope.

HYDRAULIC SYSTEM:—

RESERVOIR — 154 gallons (583 liters) capacity, all steel fabrication with internal baffles, clean out access, exterior oil sight level gauge.

FILTER — Tank mounted, return line replaceable cartridge with bypass protection and filter by-pass indicator. 25 micron rating.

PUMPS — Four main gear pumps, 146 GPM (553 LPM) combined capacity. Power steering 18.7 GPM (17.1 LPM). Pump disconnect lever operated from carrier deck.

CONTROL VALVES — Precision four-way double-acting with integral load holding, main circuit relief valves. Four individual valve banks permitting simultaneous independent control. Maximum operating pressure 2500 PSI (175.8 kg/cm²).

OIL COOLER — Full flow, fin and tube, oil to air.

POWER DISTRIBUTION — Main hoist, auxiliary hoist boost - 46 GPM (174.1 LPM) @ 2500 PSI (175.8 kg/cm²); auxiliary hoist, main hoist boost, lift, mid-telescope - 46 GPM (174.1 LPM) @ 2500 PSI (175.8 kg/cm²); lift boost, rear steer, fly telescope, outriggers - 26 GPM (98.4 LPM) @ 2500 PSI (175.8 kg/cm²); swing - 26 GPM (98.4 LPM) @ 2500 PSI (175.8 kg/cm²).

MISCELLANEOUS STANDARD EQUIPMENT — Complete light package, tool box and storage compartment, fenders, hookblock tie-down, ether injection cold starting aid, rear view mirror, 2-3/4 lb. (1.3 kg) dry type fire extinguisher, door and window locks, hoist drum rotation indicator, seat belt, rear wheel steer alignment indicator.

***MISCELLANEOUS OPTIONAL EQUIPMENT** — Tire inflation kit, automatic back-up alarm, front and/or rear pintle hooks.

*Denotes Optional Equipment.

the FRAME

EASY MANEUVERABILITY

Full power hydraulic steering with 4-steering modes permits 4-wheel coordinated, 4-wheel crabbing, 2-wheel (front & rear) steering for easier maneuvering in tight quarters. Grove's system of independent control for each axle permits a greater degree of maneuverability with greater ease for the operator.

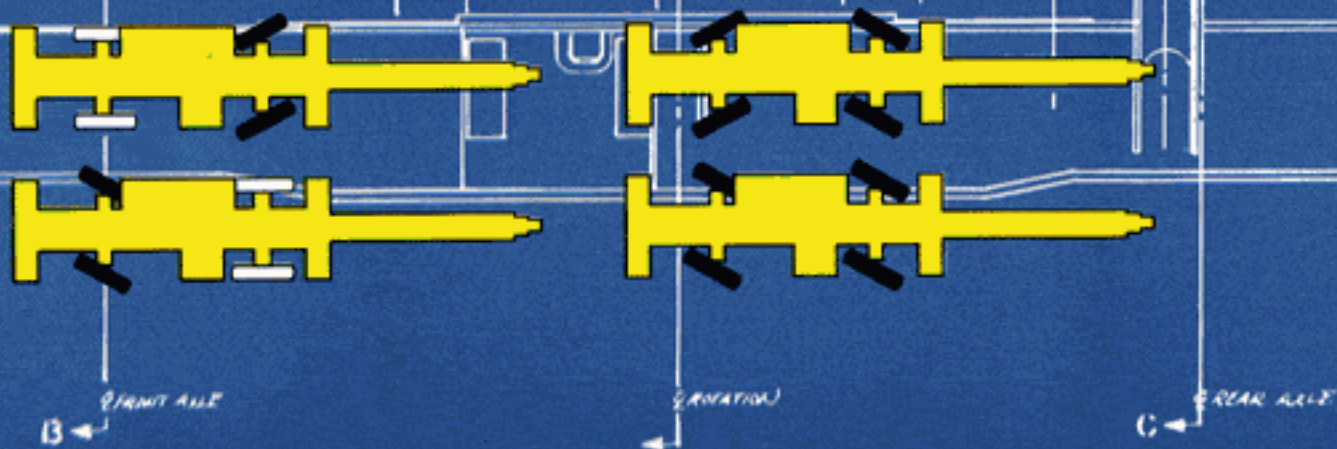

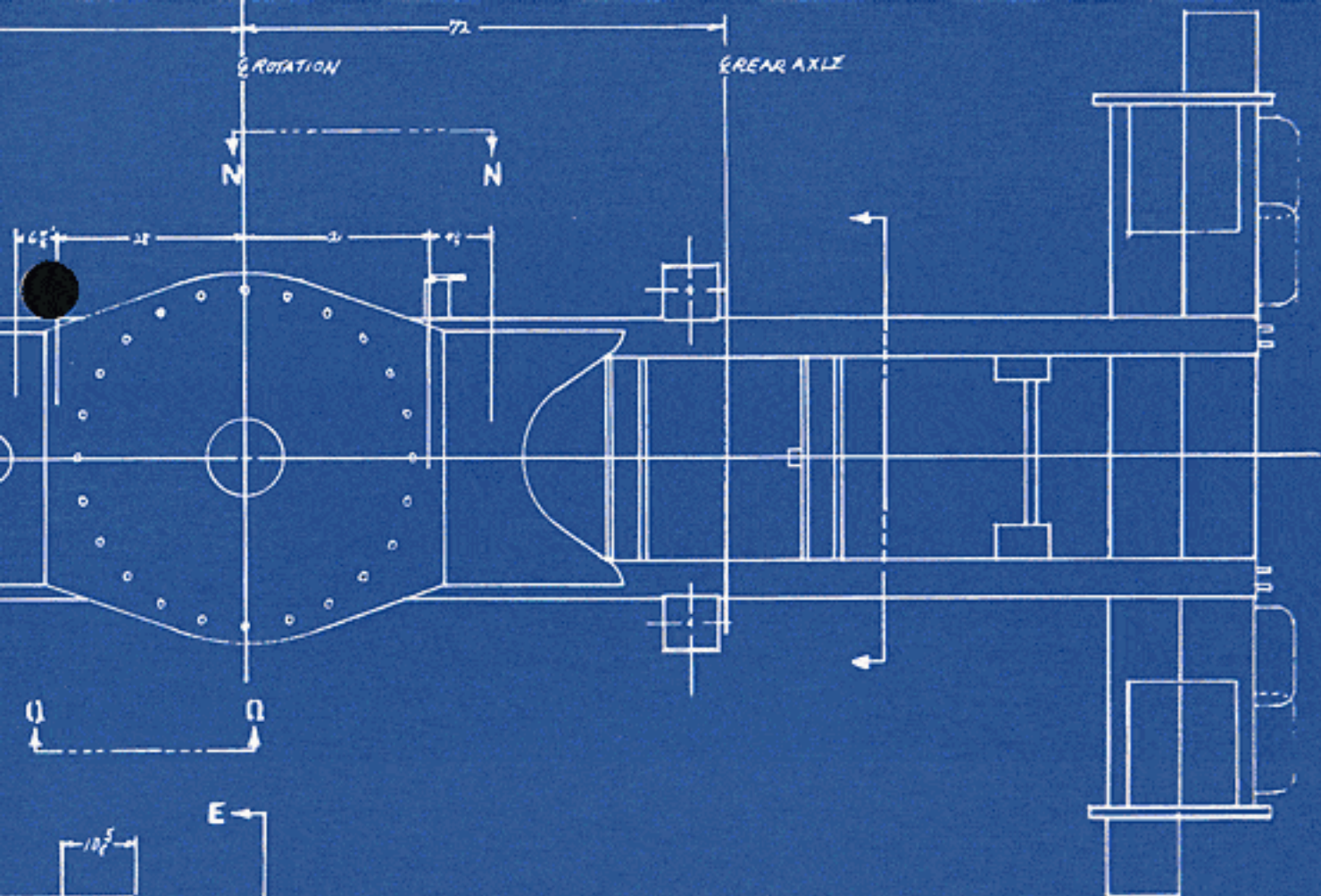

ENGINEERED FOR...
Strength & Agility

HOIST SPECIFICATIONS

Description: Series parallel circuitry and two motors provide both high line pull and speed ranges. Power up and down, equal speed, planetary reduction with integral automatic brake plus electronic hoist drum rotation indicator.			Description: Power up and down, equal speed, planetary reduction with integral automatic brake plus electronic hoist drum rotation indicator.				
HOIST DATA	MAIN HOIST Grove Model HO-30B-16	*AUXILIARY HOIST Grove Model HO-30B-16	*AUXILIARY HOIST Grove Model HO-15H-16B	*AUXILIARY HOIST (Controlled Free Fall) Gearmatic Model 25			
Drum Dimensions	16 in. diameter (406mm) 16 in. length (406mm) 24 in. flange diameter (610mm)	16 in. diameter (406mm) 16 in. length (406mm) 24 in. flange diameter (610mm)	12 in. diameter (305mm) 16 in. length (406mm) 17.5 in. flange diameter (445mm)	9 in. diameter (229mm) 13 in. length (303mm) 17.5 in. flange diameter (445mm)			
Performance:							
Max. Single Line Speed:	Hi-Speed Range	Lo-Speed Range	Hi-Speed Range	Lo-Speed Range	5/8 in. (16mm) Rope	1/2 in. (13mm) Rope	1/2 in. (13mm) Rope
Bare Drum	385 FPM (117.3m/min)	195 FPM (59.4m/min)	385 FPM (117.3m/min)	195 FPM (59.4m/min)	287 FPM (87.5m/min)	287 FPM (87.5m/min)	155 FPM (35m/min)
Mean Drum	460 FPM (140.2m/min)	230 FPM (70.1m/min)	460 FPM (140.2m/min)	230 FPM (70.1m/min)	327 FPM (99.7m/min)	340 FPM (103.6m/min)	202 FPM (61.6m/min)
Full Drum	525 FPM (160m/min)	265 FPM (80.8m/min)	525 FPM (160m/min)	265 FPM (80.8m/min)	379 FPM (115.5m/min)	383 FPM (116.7 m/min)	290 FPM (88.4m/min)
Max. Single Line Pull:							
Bare Drum	8,400 lbs. (3810kg)	16,800 lbs. (7620kg)	8,400 lbs. (3810kg)	16,800 lbs. (7620kg)	9,165 lbs. (4157kg)	9,165 lbs. (4157kg)	9,145 lbs. (4148kg)
Mean Drum	6,945 lbs. (3150kg)	13,890 lbs. (6301kg)	6,945 lbs. (3150kg)	13,890 lbs. (6301kg)	8,025 lbs. (3640kg)	7,730 lbs. (3560kg)	7,150 lbs. (3222kg)
Full Drum	6,125 lbs. (2778kg)	12,245 lbs. (5554kg)	6,125 lbs. (2778kg)	12,245 lbs. (5554kg)	6,930 lbs. (3143 kg)	6,890 lbs. (3125kg)	5,065 lbs. (2297kg)
Drum Rope Capacity + Max. Storage	650 ft. of 3/4 in. dia. rope (198m of 19mm)	650 ft. of 3/4 in. dia. rope (198m of 19mm)	650 ft. of 3/4 in. dia. rope (198m of 19mm)	650 ft. of 3/4 in. dia. rope (198m of 19mm)	480 ft. of 5/8 in. dia. rope (146.3m of 16mm)	720 ft. of 1/2 in. dia. rope (219.6m of 13mm)	680 ft. of 1/2 in. dia. rope (205.7m of 13mm)
++ Max. Usable	540 ft. of 3/4 in. dia. rope (166.6m of 19mm)	540 ft. of 3/4 in. dia. rope (166.6m of 19mm)	540 ft. of 3/4 in. dia. rope (166.6m of 19mm)	540 ft. of 3/4 in. dia. rope (166.6m of 19mm)	365 ft. of 5/8 in. dia. rope (111.2m of 16mm)	585 ft. of 1/2 in. dia. rope (178m of 13mm)	575 ft. of 1/2 in. dia. rope (168m of 13mm)
Permissible Single Line Rope Pull w/ 3.5:1 Safety Factor	3/4 in. (19mm) 6x41 class 14,605 lbs. (6625kg) 3/4 in. (19mm) 19x7 class 13,700 lbs. (6214kg)	3/4 in. (19mm) 6x41 class 14,605 lbs. (6625kg) 3/4 in. (19mm) 19x7 class 13,700 lbs. (6214kg)	3/4 in. (19mm) 6x41 class 14,605 lbs. (6625kg) 3/4 in. (19mm) 19x7 class 13,700 lbs. (6214kg)	3/4 in. (19mm) 6x41 class 14,605 lbs. (6625kg) 3/4 in. (19mm) 19x7 class 13,700 lbs. (6214kg)	5/8 in. (16mm) 6x41 class 9,165 lbs. (5339kg) 5/8 in. (16mm) 19x7 class 8,700 lbs. (3496kg)	1/2 in. (13mm) 6x37 class 7,600 lbs. (3447kg) 1/2 in. (13mm) 19x7 class 6,150 lbs. (2790kg)	1/2 in. (13mm) 6x37 class 7,600 lbs. (3447kg) 1/2 in. (13mm) 19x7 class 6,150 lbs. (2790kg)

*Denotes Optional Equipment.

+6th layer of rope not recommended for hoisting operations (5th layer for model HO15H-16B hoist; 9th layer for Gearmatic Model 25-SGECR).

++With wire rope minimum 1/2 in. (13mm) below top of drum flange.

19x7 is a non-spin rope intended for single line operation and is not recommended for multiple part reeving.

ENGINE SPECIFICATIONS

MAKE & MODEL	Detroit Diesel 6V-53N	*Cummins Diesel V555-C200	*Caterpillar 3208 Diesel
TYPE	6 Cylinder O.H.V.	8 Cylinder O.H.V.	8 Cylinder O.H.V.
BORE & STROKE	3.875 in. x 4.50 in. (98mm x 114mm)	4.625 in. x 4.125 in. (117mm x 105mm)	4.5 in. x 5.0 in. (114mm x 127mm)
DISPLACEMENT	318 cu.in. (5212cm ³)	555 cu.in. (9096cm ³)	636 cu.in. (10 424cm ³)
HORSEPOWER (NET)	170 @ 2500 RPM	180 @ 2600 RPM	178 @ 2600 RPM
GOVERNED RPM	2500	2600	2600
TORQUE (NET)	392 lbs. ft. (54kg.m) @ 1500 RPM	380 lbs. ft. (53kg.m) @ 1850 RPM	468 lbs. ft. (65kg.m) @ 1200 RPM
ELECTRICAL SYSTEM	12-Volt, Negative Ground	12-Volt, Negative Ground	12-Volt, Negative Ground
COMBUSTION SYSTEM	2 Cycle with blower	4 Cycle, Naturally Aspirated	4 Cycle, Naturally Aspirated
COOLING SYSTEM	Liquid	Liquid	Liquid
FUEL CAPACITY	60 Gallon (227 liters)	60 Gallon (227 liters)	60 Gallon (227 liters)
ALTERNATOR	65 Amp, 12-volt	58 Amp, 12-volt	55 Amp, 12-volt
BATTERY	• (2) 12 volt 825 CCA@ 0° F	• (2) 12 volt 825 CCA@ 0° F	• (2) 12 volt 825 CCA@ 0° F
AIR CLEANER	Dry Type	Dry Type	Dry Type
AIR COMPRESSOR	7.25 CFM	13.2 CFM	12 CFM
HOURMETER	Yes	Yes	Yes

*Denotes Optional Equipment

• CCA=Cold cranking amperage per battery.

AXLE WEIGHT DISTRIBUTION CHART

ITEM	POUNDS			KILOGRAMS		
	GVW	FRONT	REAR	GVW	FRONT	REAR
Basic standard machine to include: 34 ft. - 84 ft. (10.4-25.6m) 3-section trapezoidal main boom; 32 ft. (9.8m) swingaway section; HO 30B-16 main hoist with 500 ft. (152.4m) of 3/4 in. (19mm) diameter rope; GM6V-53N engine; 12,000 lb. (5443 kg) counterweight; 29.5x25-22PR tires.	84,887	39,554	45,333	38,505	17,942	20,563
ADD:						
Auxiliary boom nose	+200	+582	-382	+91	+264	-173
24 ft. (7.3m) A-frame jib (stowed)	+907	+1,003	-96	+411	+455	-44
55 ton hookblock	+1,100	+1,796	-696	+499	+815	-316
HO 30B-16 auxiliary hoist w/400 ft. (121.9m) of 3/4 in (19mm) rope	+483	-258	+741	+219	-117	+336
HO 15H-16B auxiliary hoist w/400 ft. (121.9m) of 1/2 in. (13mm) rope	+364	-163	+527	+165	-74	+239
Gearmatic Model 25 auxiliary hoist w/400 ft. (121.9m) of 1/2 in. (13mm) rope	+406	-173	+579	+184	-79	+263
SUBSTITUTE:						
35 ft. - 110 ft. (10.6-33.5m) 4 section trapezoidal main boom	+3,450	+3,765	-315	+1,565	+1,708	-143
Cummins V555 - C200 engine	+170	-45	+215	+77	-20	+97
Cat 3208 engine	-128	+34	-126	-58	+15	-73
29.5x25-28PR tires	+400	+200	+200	+182	+91	+91
26.5x25-26PR tires	-1,336	-668	-668	-606	-303	-303
● 11,350 lb (5148 kg) counterweight	11,350	-5,387	+16,737	5,148	-2,444	+7,592
● 10,250 lb (4649 kg) counterweight	10,250	-4,865	+15,115	4,649	-2,207	+6,856
● 13,000 lb (5897 kg) counterweight	13,000	-6,171	+19,171	5,897	-2,799	+8,696
● 12,350 lb (5602 kg) counterweight	12,350	-5,862	+18,212	5,602	-2,659	+8,261
REMOVE:						
HO 30B-16 main hoist w/500 ft. (152.4m) of 3/4 in. (19mm) diameter rope	-2,324	+775	-3,099	-1,054	+352	-1,406
32 ft. (9.8m) swingaway section	-2,100	-3,065	+965	-953	-1,390	+437
34 ft. -84 ft. (10.4-25.6m) 3 section trapezoidal main boom	-15,230	-19,930	+4,700	-6,908	-9,040	+2,132
34 ft. -84 ft. (10.4-25.6m) 3 section trapezoidal main boom and lift cylinders	-17,610	-22,252	+4,642	-7,988	-10,094	+2,106
Outrigger beams and jacks (front)	-2,837	-3,906	+1,069	-1,287	-1,772	+485
Outrigger beams and jacks (rear)	-2,837	+1,296	-4,133	-1,287	+588	-1,875
● 12,000 lb. (5443 kg) counterweight	-12,000	+5,696	-17,696	-5,433	+2,584	-8,027

- **NOTE:** Appropriate counterweight substitutions must be made depending on main and auxiliary hoist configuration specified.
- 12,000 lb. (5443 kg) counterweight used with 3 section main boom and no auxiliary hoist.
- 11,350 lb. (5148 kg) counterweight used with 3 section main boom and HO 15H-16B or Gearmatic Model 25 auxiliary hoist, or with 4 section main boom and HO 30B-16 auxiliary hoist.
- 10,250 lb. (4649 kg) counterweight used with 3 section main boom and HO 30B-16 auxiliary hoist.
- 13,000 lb. (5897 kg) counterweight used with 4 section main boom and no auxiliary hoist.
- 12,350 lb. (5602 kg) counterweight used with 4 section main boom and HO 15H-16B or Gearmatic Model 25 auxiliary hoist.

SPEED AND GRADEABILITY

Forward Drive	Transmission Range	Gear Shift	Maximum Speed		Gradeability @ Stall (%)	Tractive Effort at Stall	
			MPH	KM/H		LBS.	KG
4 Wheel Drive	Low	1st	1.4	2.3	128.1	71,134	32,266
4 Wheel Drive	Low	2nd	3.0	4.8	38.9	33,649	15,263
4 Wheel Drive	Low	3rd	7.8	12.6	12.1	12,330	5,593
2 Wheel Drive	High	1st	4.0	6.4	27.0	24,716	11,211
2 Wheel Drive	High	2nd	8.2	13.2	11.3	11,673	5,295
2 Wheel Drive	High	3rd	20.3	32.7	2.9	4,274	1,939

NOTE: All performance data is based upon standard machine and may vary plus or minus 10% due to variations in engine performance. Gradeability values above 45° are theoretical. Machine should be operated within the limits of engine crankcase design (15°-GM; 30°-CAT and Cummins).



RT755

When **TIME & AVAILABILITY** means **PROFIT**

When evaluating mobile cranes, you're looking for the best combination of performance, reliability, and profit-potential. Equipment owners or renters realize full well that no piece of equipment can meet those objectives if it's not available to work. At Grove, we have a commitment to see that your mobile hydraulic crane is built right, performs right, and to make it as convenient as possible to have it maintained right. More than ever, time on or off the work-site means money. You want your downtime to be a bare minimum, and the RT755 has been designed and built to help you fill that desire.

And, you'll appreciate the inherent Measurable Value of your Grove when you decide to trade up or sell. Historically, a Grove Crane brings a substantially higher resale price than competitive makes. It's logical for the NUMBER ONE crane to be in higher demand. It's simply added evidence of the lowest total cost in your Grove investment!