

GROVE

40 TON CAPACITY

36 TONS METRIC

GEAR PAD LOCATION

STATIC RADIUS

2. POSITION 89

R T 7 4 0



WORLD LEADER IN

HYDRAULIC CRANES



HIGH DUTY-CYCLE PERFORMANCE!

- 4 MULTIPLE, SIMULTANEOUS CRANING FUNCTIONS
- GROVE 2-SPEED HOISTS
- SMOOTH, SURE "GLIDESWING"
- PRECISION SWING BRAKE

EFFICIENCY-DESIGNED OPERATOR'S CAB

- FULL-VISION, FULLY ENCLOSED
- COMBINATION HAND/FOOT CONTROLS
- ACOUSTICALLY-TREATED; MOUNTED ON RUBBER GROMMETS
- STANDARDIZED LAYOUT MATCHES ANY OTHER GROVE CRANE

CONSTANT IMPROVEMENT AND ENGINEERING PROGRESS MAKE IT NECESSARY THAT WE RESERVE THE RIGHT TO MAKE SPECIFICATION, EQUIPMENT AND PRICE CHANGES WITHOUT NOTICE. ILLUSTRATIONS SHOWN MAY INCLUDE OPTIONAL EQUIPMENT AND ACCESSORIES AND MAY NOT INCLUDE ALL STANDARD EQUIPMENT. OPTIONAL EQUIPMENT IS DESIGNATED BY (*) IN SPECIFICATIONS FOLDER.

¹ Patented Grove feature



RT750



GROVE TRAPEZOIDAL BOOM!

- UP TO 166 FT. (50.6M) OF TIP HEIGHT
- STOWABLE "SWINGAWAY" AND A-FRAME JIB
- JIB OFFSETS TO 30°

TOP JOBSITE MANEUVERABILITY!

- 4-WHEEL DRIVE & STEERING
- 4 SEPARATE STEERING MODS
- REAR-AXLE OSCILLATION
- SUPERIOR "PICK-AND-CARRY" CAPACITIES

PERFORMANCE ENGINEERED

A NEW LEVEL OF EXCELLENCE

The total measure of a mobile hydraulic crane is how well it performs in a wide variety of jobsite situations – maximum lifts, long boom reach, close-quarter telescoping action, high duty-cycling, pick-and-carry, as well as precision load placement. On the job is where the simplified design and reliability of the Grove RT740 really shine – in terms of bottom line, total-performance ratings. This 40-tonner draws on a long line of rough terrain leaders with a respected record of profitable jobsite performance!



RT740

AN EXCLUSIVE GROVE TRAPEZOIDAL† BOOM WITH OPTIMUM STRENGTH-TO-WEIGHT RATIO FOR GREATER REACH AND LIFT CAPACITY!



66 ft. (50.6m) OF TIP HEIGHT WITH

"SWINGAWAY" & JIB!

JIB OFFSETS TO
5° - 17° - 30°



STABLE LIFTING
AT LONG RADII

A standard 32 ft. (9.7m) lattice boom extension stows alongside the base section, ready to be swung into position and pinned. An optional 24 ft. (7.3m) A-frame jib stows beneath the "Swingaway" and is held in place even when the extension is used independently. The result? — An "on board" tip-height potential of 166 ft. (50.6m) for valuable up-and-over jobsite reach!

The all-welded, reinforced frame creates a strong, rigid lifting base, augmented by a wide 23 ft. (7.0m) outrigger stance for impressive lifting capability at longboom reaches. The lift illustrated above involves a load of 1,800 lbs. (816.5kg) at approximately 95 ft. (29m) radius, using the RT740's extended power-pinned fly section.

† For a detailed description of the Grove Patented Trapezoidal Boom, refer to the inside back cover.

REACH & CAPACITY

TIP HEIGHTS

6,000 lbs.
(2720 kg)

165ft. - 24" A" FRAME JIB
(50.3m)

9,600 lbs.
(4355 kg)

142ft. - 32" SWINGAWAY
(43.3m)

19,500 lbs.
(8845 kg)

111ft. - MAIN BOOM
(33.8m)

TRAPEZOIDAL BOOM

GROVE LONG-REACH TRAPEZOIDAL BOOM

Backed by nearly ten years of superior jobsite performance, the Grove Trapezoidal Boom design has proved its value as an exclusive Grove advanced engineering accomplishment. Starting with very high strength steels, the design creates a deeper, wider, and lighter structure that permits lifting heavier loads to longer-boom reaches – and offers exceptional rigidity and resistance to long-reach vertical and lateral deflection. It's a prime example of Grove performance-engineering!



Dual, double-acting lift cylinders permit a maximum boom elevation of 76° as well as -4°. The negative angle facilitates boomhead reeving and the procedure for power-pinned fly extension and retraction – all for easier, faster set-up!

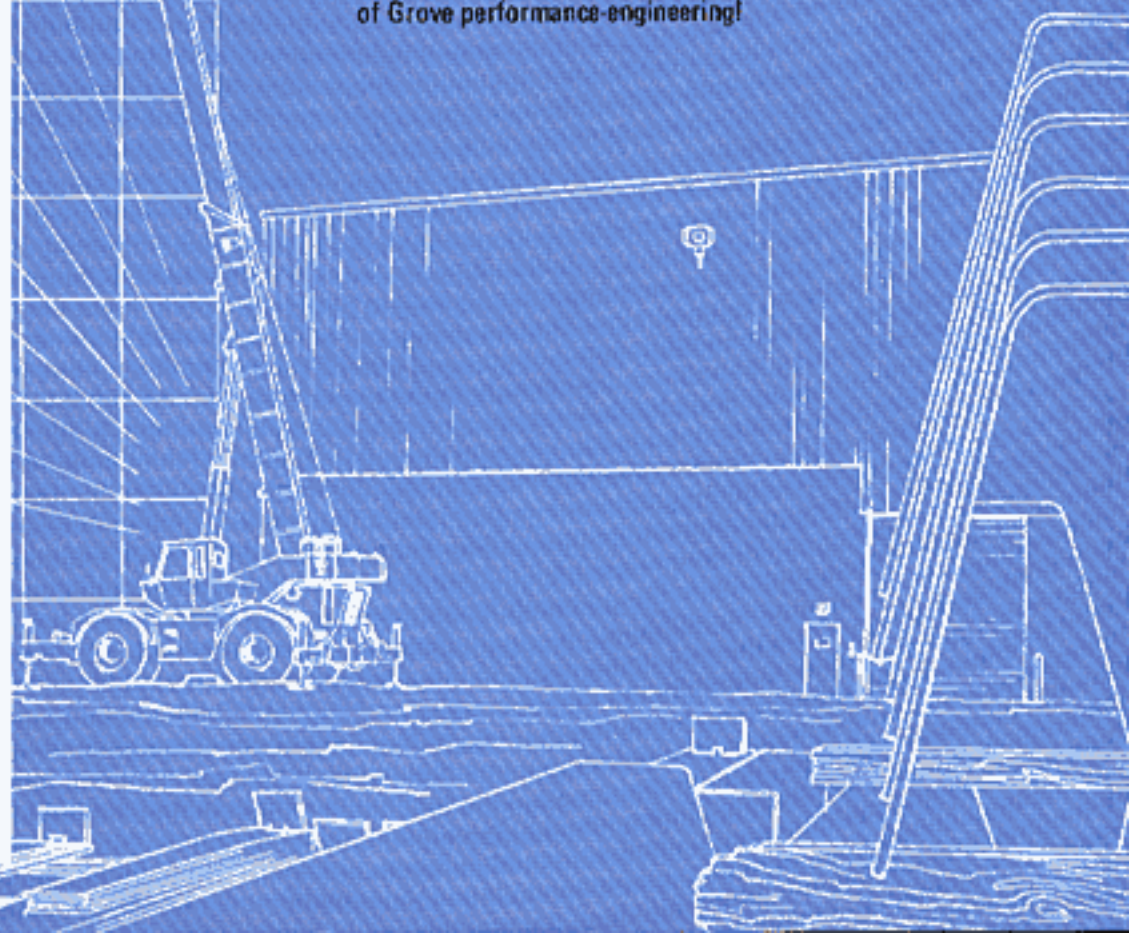

RT740

DIMENSIONS

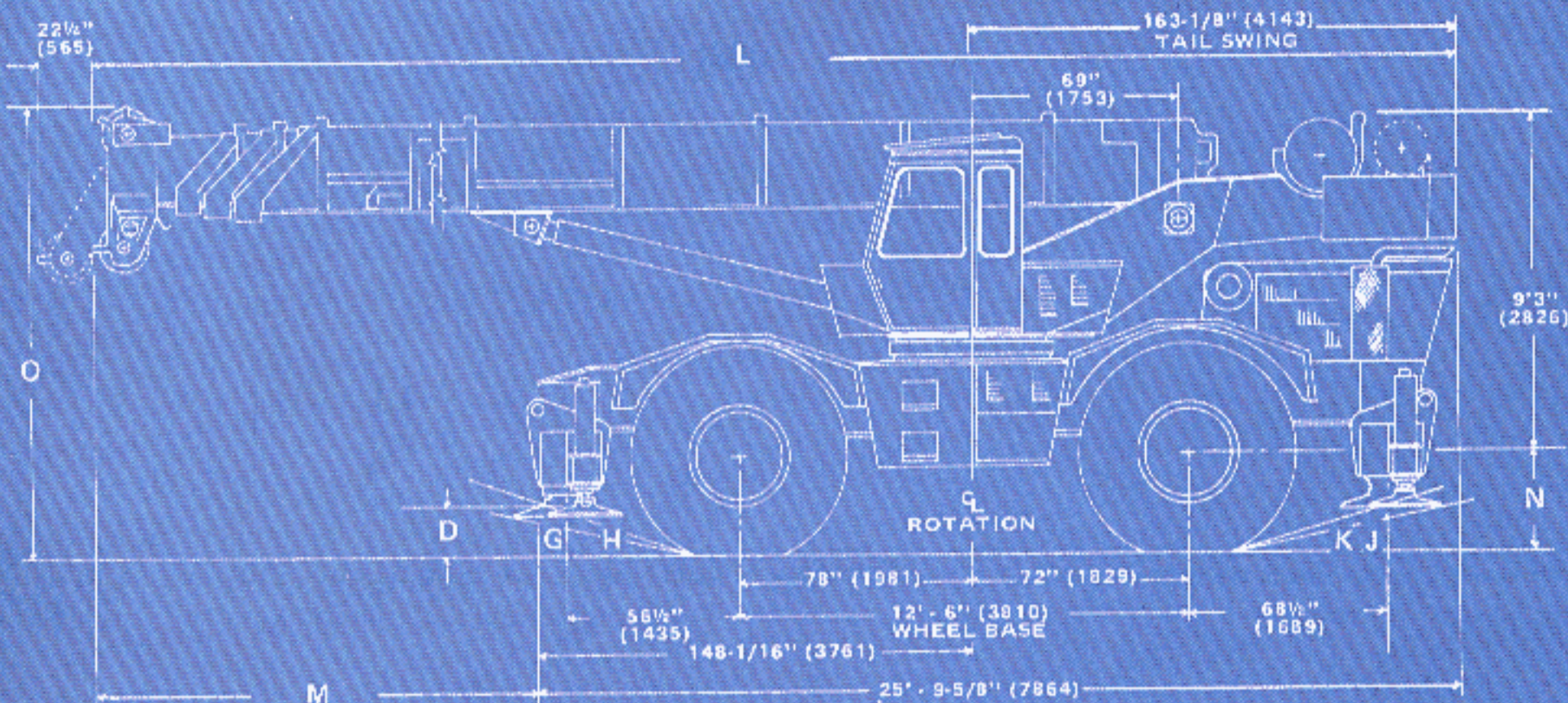

TIRE SIZE	A	B	C	D	E	F	G	H	J	K	N	O
21.00x25	70 in. (1778)	96-1/2 in. (2451)	10 ft. 3 in. (3124)	16-1/8 in. (410)	12-1/16 in. (306)	5-3/8 in. (137)	14°	9°	12°	8°	30-1/2 in. (775)	12 ft. 4-9/16 in. (3774)
26.5x25	67 in. (1702)	97-1/2 in. (2477)	10 ft. 8 in. (3251)	16-1/2 in. (419)	12-1/2 in. (318)	5-3/8 in. (137)	15°	10°	13°	8°	31 in. (787)	12 ft. 5 in. (3785)
29.5x25	66 in. (1676)	98-1/2 in. (2502)	10 ft. 11 in. (3327)	18-1/2 in. (470)	11-7/8 in. (302)	5-3/8 in. (137)	16°	11°	14°	9°	32-13/16 in. (833)	12 ft. 6-7/8 in. (3832)

BOOM LENGTH	L	M
33 ft.-112 ft. (10.0-33.9m)	41 ft. 3 in. (12,573)	15 ft. 5-3/8 in. (4709)
34 ft.-136 ft. (10.3-41.4m)	42 ft. 3-1/2 in. (12,891)	16 ft. 5-7/8 in. (5026)

() DIMENSIONS IN MILLIMETERS

TURNING RADIUS 23 ft. 4 in. (7112)
(4 WHEEL STEER)

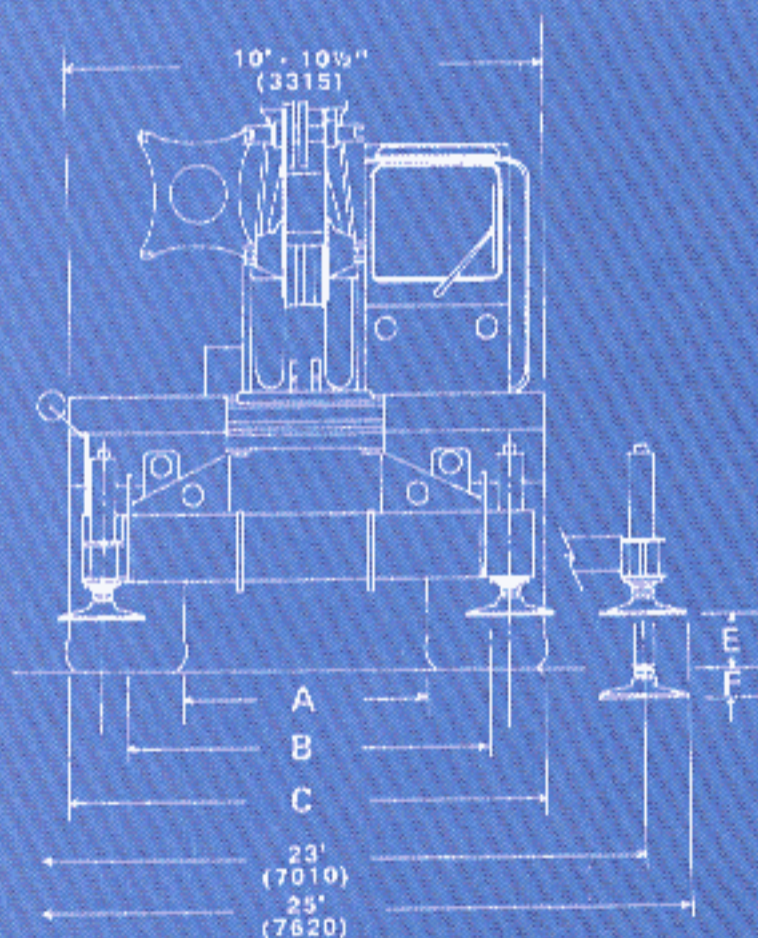

GROVE MANUFACTURING COMPANY

Division of Walter Kidde & Company, Inc.

KIDDE

SHADY GROVE, PA 17256

DEALER:

**HYDRAULIC
CRANES**

TITLE

**RT740 / ROUGH TERRAIN CRANE
4x4**

FORM NO.

SBRT740(5-80)-20M

RT740



GROVE MANUFACTURING COMPANY

Division of Walter Kidde & Company, Inc.

KIDDE

SHADY GROVE, PA 17256



CHASSIS SPECIFICATIONS

MAIN FRAME — All welded parallel box beam construction with full depth longitudinals braced by crossmembers reinforced at critical points to resist torsional stresses and provide a strong, rigid lifting base. Precision machined bearing mounting surface prevents distortion of swing bearing. Front and rear combination lifting/towing and tie-down lugs are integral with main frame.

OUTRIGGERS — Front and rear hydraulic double-box integral with main frame; telescoping beams extend to 23 ft. (7.0m) and retract to 11 ft. (3.35m) by 3 in. (76mm) diameter bore, 77-3/4 in. (1,975mm) stroke double-acting cylinders. 21 in. (533mm) stroke, 6 in. (152mm) diameter bore double-acting vertical jacks with integral check valves provide quick leveling on uneven terrain. Vertical jacks equipped with removable, stowable, lightweight, high strength 24 in. (610mm) diameter steel floats. All outrigger control located in operator's cab. Required sequence control arrangement eliminates unintentional outrigger actuation. In addition to the standard integral holding valve and for added security, the exclusive Grove *spin-lock is offered which permits the outrigger vertical jack to be mechanically locked in any position throughout its stroke.

TRANSMISSION & TORQUE CONVERTER — Remote-mounted full powershift transmission with 6 speeds forward and reverse with rear axle disconnect. Engine-mounted torque converter 1.82:1 stall ratio with PTO for hydraulic pumps.

SPEEDS — 6 forward and 6 reverse
3 speeds - High range — 2-wheel drive
3 speeds - Low range — 4-wheel drive

AXLES — Front: planetary drive/steer type mounted rigid to the frame. Total reduction ratio 26.6:1
Rear: planetary drive/steer type mounted to allow 0 in. to 10 in. (254mm) oscillation for rough terrain negotiation. Total reduction ratio 26.6:1. No-spin rear axle.

HYDRAULIC OSCILLATION LOCKOUTS — Automatic, full hydraulic on rear axle. Permits rear axle oscillation only with boom over front. Rear axle lockout assures a rigid lifting platform when lifting on-rubber over-the-side. *Manually activated electric override control.

STEERING — Front: power assist hydraulic; controlled by steering wheel. Dual steering cylinders.

Rear: full hydraulic; tiller bar control. Dual steering cylinders. Independent front and rear steer control allows operator to choose mode of travel for optimum "on the move" maneuverability. Four modes available are: independent front wheel steer, independent rear wheel steer, 4-wheel coordinated steer and 4-wheel crab steer.

SERVICE BRAKES — Full air on all four wheels. Size 20-1/4 in. x 4 in. (514mm x 102mm) with a total lining area of 560 in.² (4,258cm²).

PARKING BRAKES — Spring set, air released emergency/parking brakes on both axles.

TIRES — 21:00x25-24PR (E-3) earthmover type, tubeless.

*26.5x25-26PR (E-3) earthmover type, tubeless.

*29.5x25-22PR (E-3) earthmover type, tubeless.

*29.5x25-28PR (E-3) earthmover type, tubeless.

***TOW WINCH** — Braden PD15 cab-controlled tow winch (less rope and hook), front mounted. Single line pull - 15,000 lbs. (6,804kg); single line speed - 58.9 FPM (17.9m/mm). Drum rope storage capacity of 340 ft. (103.6m) of 5/8 in. (16mm) rope.

HYDRAULIC SYSTEM:

RESERVOIR — 154 gallon (583 liter) capacity, all steel fabrication with internal baffles, clean-out access, exterior oil sight level gauge.

FILTER — Tank mounted, return line replaceable cartridge with bypass protection and filter bypass indicator. 25 micron rating.

PUMPS — Four main gear pumps, 146 FPM (553 LPM) combined capacity. Power steering pump 18.7 GPM (71 LPM). Pump disconnect lever operated from carrier deck.

CONTROL VALVES — Precision four-way double-acting with integral load holding, main and circuit relief valves. Four individual valve banks permit simultaneous multiple function operation. Maximum operating pressure 2,500 PSI (175.8kg/cm²).

OIL COOLER — Full flow, fin and tube, oil to air.

POWER DISTRIBUTION — Main hoist, *auxiliary hoist boost - 46 GPM (174.1 LPM) @ 2,500 PSI (175.8kg/cm²); Main hoist boost, *auxiliary hoist, lift, mid-telescope - 46 GPM (174.1 LPM) @ 2,500 PSI (175.8kg/cm²); Lift boost, rear steer, fly telescope, outriggers - 26 GPM (98.4 LPM) @ 2,500 PSI (175.8kg/cm²); swing - 26 GPM (98.4 LPM) @ 2,500 PSI (175.8kg/cm²).

MISCELLANEOUS STANDARD EQUIPMENT — Complete light package, tool box and storage compartment, fenders, hookblock, tie-down, ether injection cold starting aid, rear view mirror, 2-3/4 lb. (1.3kg) dry type fire extinguisher, door and window locks, hoist drum rotation indicator, seat belt, rear wheel steer alignment indicator.

MISCELLANEOUS OPTIONAL EQUIPMENT — Tire inflation kit, automatic back-up alarm, front and/or rear pintle hooks.

*Dentoes optional equipment.

HOIST SPECIFICATIONS

Description: Series parallel circuitry and two motors provide both high line pull and speed ranges. Power up and down, equal speed, planetary reduction with integral automatic brake plus electronic hoist drum rotation indicator.		Description: Power up and down, equal speed, planetary reduction with integral automatic brake plus electronic hoist drum rotation indicator.		
HOIST DATA	MAIN HOIST Grove Model HO-30B-16	*AUXILIARY HOIST Grove Model HO-30B-16	*AUXILIARY HOIST Grove Model HO-15H-16B	*AUXILIARY HOIST (Controlled Free Fall) Gearmatic Model 25
Drum Dimensions	16 in. diameter (406mm) 16 in. length (406mm) 24 in. flange diameter (610mm)	16 in. diameter (406mm) 16 in. length (406mm) 24 in. flange diameter (610mm)	12 in. diameter (305mm) 16 in. length (406mm) 17.5 in. flange diameter (445mm)	9 in. diameter (229mm) 13 in. length (330mm) 17.5 in. flange diameter (445mm)
Performance:				
Max. Single Line Speed:	Hi-Speed Range Lo-Speed Range	Hi-Speed Range Lo-Speed Range	5/8 in. (16mm) Rope 1/2 in. (13mm) Rope	1/2 in. (13mm) Rope
Bare Drum	385 FPM (117.3m/min) 195 FPM (59.4m/min)	385 FPM (117.3m/min) 195 FPM (59.4m/min)	287 FPM (87.5m/min) 287 FPM (87.5m/min)	155 FPM (35m/min)
Mean Drum	460 FPM (140.2m/min) 230 FPM (70.1m/min)	460 FPM (140.2m/min) 230 FPM (70.1m/min)	327 FPM (99.7m/min) 340 FPM (103.6m/min)	202 FPM (61.6m/min)
Full Drum	525 FPM (160m/min) 265 FPM (80.8m/min)	525 FPM (160m/min) 265 FPM (80.8m/min)	379 FPM (115.5m/min) 383 FPM (116.7 m/min)	290 FPM (88.4m/min)
Max. Single Line Pull:				
Bare Drum	8,400 lbs. (3810kg) 16,800 lbs. (7620kg)	8,400 lbs. (3810kg) 16,800 lbs. (7620kg)	9,165 lbs. (4157kg) 9,165 lbs. (4157kg)	9,145 lbs. (4148kg)
Mean Drum	6,945 lbs. (3150kg) 13,890 lbs. (6301kg)	6,945 lbs. (3150kg) 13,890 lbs. (6301kg)	8,025 lbs. (3640kg) 7,730 lbs. (3560kg)	7,150 lbs. (3222kg)
Full Drum	6,125 lbs. (2778kg) 12,245 lbs. (5554kg)	6,125 lbs. (2778kg) 12,245 lbs. (5554kg)	6,930 lbs. (3143 kg) 6,890 lbs. (3125kg)	5,065 lbs. (2297kg)
Drum Rope Capacity				
+ Max. Storage	650 ft. of 3/4 in. dia. rope (198m of 19mm)	650 ft. of 3/4 in. dia. rope (198m of 19mm)	480 ft. of 5/8 in. dia. rope 720 ft. of 1/2 in. dia. rope (146.3m of 16mm) (219.6m of 13mm)	680 ft. of 1/2 in. dia. rope (205.7m of 13mm)
++ Max. Usable	540 ft. of 3/4 in. dia. rope (166.6m of 19mm)	540 ft. of 3/4 in. dia. rope (166.6m of 19mm)	365 ft. of 5/8 in. dia. rope 585 ft. of 1/2 in. dia. rope (111.2m of 16mm) (178m of 13mm)	575 ft. of 1/2 in. dia. rope (168m of 13mm)
Permissible Single Line Rope Pull w/ 3.5:1 Safety Factor	3/4 in. (19mm) 6x41 class 14,605 lbs. (6625kg) 3/4 in. (19mm) 19x7 class 13,700 lbs. (6214kg)	3/4 in. (19mm) 6x41 class 14,605 lbs. (6625kg) 3/4 in. (19mm) 19x7 class 13,700 lbs. (6214kg)	5/8 in. (16mm) 6x41 class 1/2 in. (13mm) 6x37 class 9,165 lbs. (5339kg) 7,600 lbs. (3447kg) 5/8 in. (16mm) 19x7 class 1/2 in. (13mm) 19x7 class 8,700 lbs. (3496kg) 6,150 lbs. (2790kg)	1/2 in. (13mm) 6x37 class 7,600 lbs. (3447kg) 1/2 in. (13mm) 19x7 class 6,150 lbs. (2790kg)

*Denotes Optional Equipment.

+6th layer of rope not recommended for hoisting operations (5th layer for model HO15H-16B hoist; 9th layer for Gearmatic Model 25-SGLCR).

++With wire rope minimum 1/2 in. (13mm) below top of drum flange.

19x7 is a non-spin rope intended for single line operation and is not recommended for multiple part reeving.

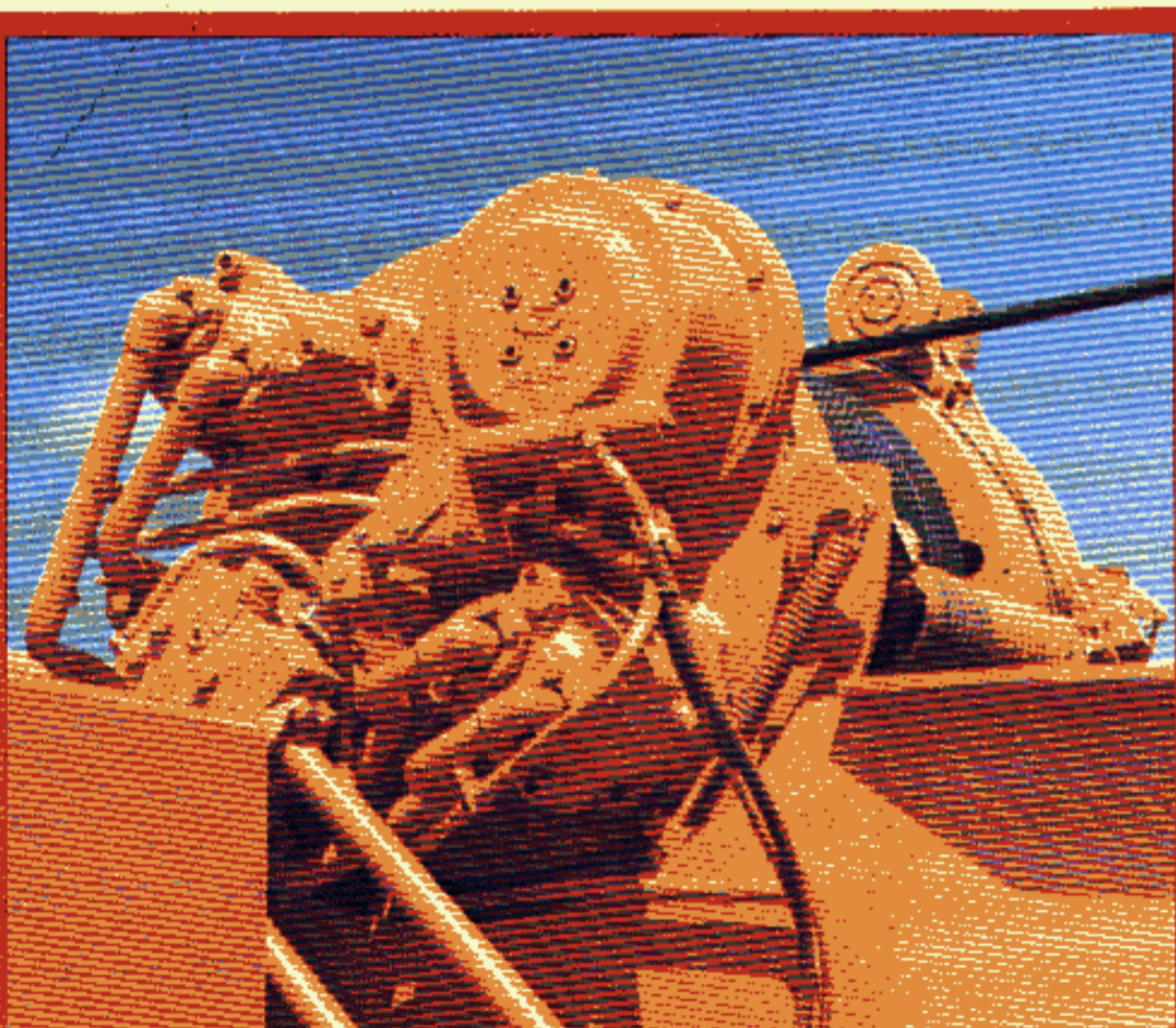



SUPERSTRUCTURE SPECIFICATIONS

BOOM — 33 ft.-112 ft. (10.0m-33.9m) total length; 3-section trapezoidal main boom consisting of base section and two full power sections to 80 ft. (24.2m) and a 32 ft. (9.8m) "swingaway" lattice boom extension to 112 ft. (33.9m).

*34 ft.-136 ft. (10.3m-41.4m) total length; 4-section trapezoidal main boom consisting of base section, two full power sections to 81 ft. (24.5m), power-pinned section to 104 ft. (31.7m) and a 32 ft. (9.8m) "swingaway" lattice boom extension to 136 ft. (41.4m). Power is supplied by two 5-1/2 in. (140mm) diameter bore 23 ft. 4-1/2 in. (7.125m) stroke double-acting cylinders with integral holding valves. Side adjustable wear pads prevent metal-to-metal contact of inner boom sections and permit ease of side boom alignment.

LATTICE BOOM EXTENSION — Standard 32 ft. (9.8m) lattice "swingaway" boom extension stows alongside base boom section. Boom extension swings into position, attaches and is held to main boom nose by four corner pins. Single metallic 17.875 in. (454mm) tread diameter sheave with removable, pin-type rope guard and rope dead-end lug.

JIB — 24 ft. (7.3m) A-frame jib attaches to sheave shaft of 32 ft. (9.8m) lattice "swingaway" boom extension. Jib stows beneath "swingaway" alongside base boom section, or can be detached from the "swingaway" and held firmly in place on the base section when "swingaway" is used independently. Jib can be offset at 5°, 17° and 30°. Includes jib backstops, single rope self-equalizing suspension and removable pin-type rope guard.

BOOM NOSE — Reinforced hi-strength steel construction. Three metallic load bearing sheaves, 17.875 in. (454mm) diameter, mounted on heavy duty tapered roller bearings. Two metallic floating idler sheaves, 17.875 in. (454mm) tread diameter mounted on anti-friction needle bearings. Removable pin-type rope guards for easy reeving. Rope dead ends on either side of boom nose. (Auxiliary boom nose is required to obtain 7 parts of line for certain international markets where 6:1 wire rope safety factor may be required.)

***AUXILIARY BOOM NOSE** — Removable, single metallic sheave, 17.875 in. (454mm) tread diameter, mounted to main boom nose for single part line work. Equipped with removable pin-type rope guard.

BOOM ELEVATION — Dual 8-1/4 in. (210mm) bore, 9 ft. 1-19/64 in. (2.776m) stroke, double-acting hydraulic cylinders with integral holding valves. Elevation -4° to 76°, combination controls for hand or foot operation.

SWING — Grove planetary speed reducer powered by a hydraulic high torque, low RPM orbit motor providing smooth/precise 360° continuous rotation. Equipped with Grove "glide swing" with foot activated multiple disc swing brake for precision stopping. Elec-

tric/hydraulic swing parking brake and two-position house lock. *Hand-operated 360° positive swing lock controlled from operator's cab. Externally driven sealed gear bearing. Precision machined mounting surface prevents distortion of swing circle bearing. Maximum speed 2.6 RPM.

CAB — Turntable mounted. Fully enclosed, all steel with acoustical treatment. Full vision with tinted safety glass throughout, removable front windshield and hinged skylight, sliding left side door and right side window for ventilation. Dash-mounted control levers, combination hand and foot controls for boom elevation and engine throttle, outrigger sight level bubble, electronic boom angle indicator with high and low angle presets and A/V warning, electric windshield wiper, air horn, door and window locks, domelight, dash-light, 2-3/4 lb. (1.2kg) dry type fire extinguisher, cab mounted worklights, 20,000 BTU diesel fuel heater, forced hot air defroster, boom elevation, swing warning system and circulating fan.

CONTROLS — Left of steering wheel are dash-mounted, hand-operated control levers for swing; boom telescope and rear steer; at right are control levers for boom elevation, *auxiliary hoist, main hoist and *free fall control. Foot-operated controls include dynamic swing brake, boom elevation, service brakes and engine throttle. Operator's right hand console includes transmission gear selection, high-low range selector, hand throttle, outrigger controls, sight level bubble, heater controls, console panel lights, engine start/stop. Additional dash-mounted controls include *electric manual oscillation lock-out override, worklights, master ignition and rear steer alignment indicator.

CAB INSTRUMENTATION — International gauges. Engine water temperature, fuel level, oil pressure, air pressure, tachometer, voltmeter, A/V warning for low air system pressure and parking brake.

COUNTERWEIGHT — Removable, bolted to turntable mast, stationary. Weight varies dependent on hoist configuration. (Refer to Axle Weight Distribution Chart.)

***LOAD MOMENT & ANTI-TWO BLOCK SYSTEM (KRUGER)** — Audio-visual warning in combination with Grove control lever lock-out of: hoist-up, telescope out and boom down crane functions. Kruger LMI control console provides operator with selective display of boom length radius and angle. *A separate anti-two block system can be obtained independent of the complete Kruger LMI, and is available with audio-visual warning only or audio-visual warning in combination with the Grove control lever lockout of: hoist-up, telescope out and boom down crane functions.

*Denotes optional equipment.



Human-Engineered OPERATOR'S COMPARTMENT

The efficiency-designed operator's cab features excellent all-around visibility and convenience of controls. It's mounted on vibration and sound-absorbing rubber grommets, and the interior is acoustically-treated to enhance operator comfort and efficiency. Levers and controls are standardized so that an operator familiar with any given Grove Crane, will be "at home" at the controls of the "740".

PRECISION DUTY-CYCLE LIFTING

Four main gear-type pumps with a combined capacity of 146 GPM (553 L/m) and precision four-way double-acting valves permit simultaneous, multi-function operation: a great operator assist — plus a smooth, sure, Grove "Glide Swing" and precision multiple disc swing brake give the RT740 outstanding duty-cycle lifting advantages.



OUTSTANDING JOBSITE MANEUVERABILITY

With boom over the front, the crane's rear axle oscillates up to 10 in. (254mm) for surefooted ground contact on rough terrain. Top maneuverability with four separate modes of steering, heavy-duty earthmover tires, and a great pick-and-carry potential combine to make this 40-tonner an outstanding performer on the rough terrain of construction jobsites.



4 SEPARATE STEERING MODES

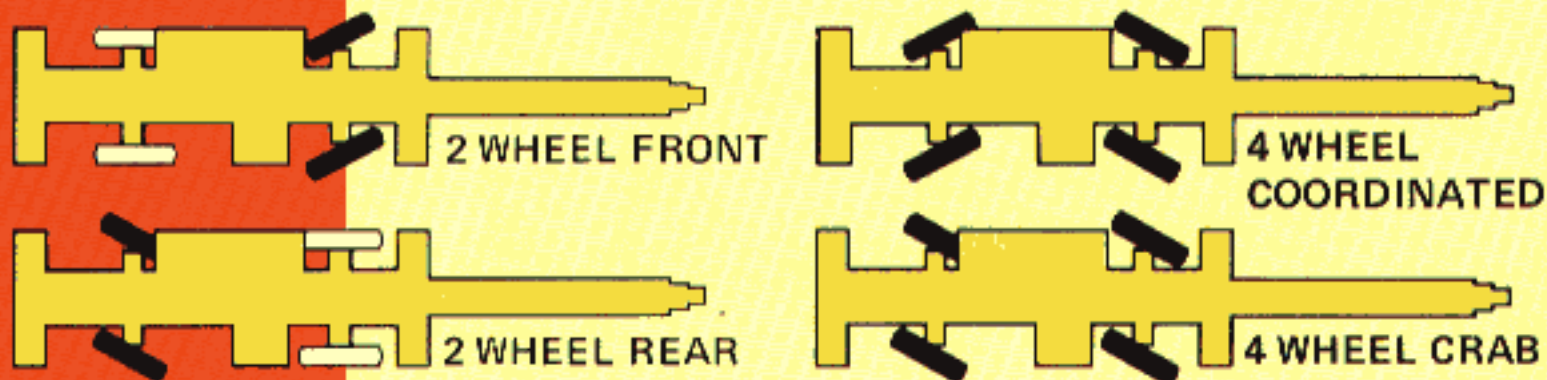

LIFT & SWING THROUGH A 360° CHART

The nearly-square outrigger stance of the RT740 produces a lifting capacity chart that, with outriggers set, is operationally 360°.

This is largely due to a strong, stable structure combining integral, double-box beams for the hydraulic outriggers with an all-welded reinforced frame built to resist torsional stresses and provide a rigid lifting base. Maximum outrigger spread is 23 feet (7.0m) on centers of vertical jacks. Exclusive Grove Spinlocks for the jacks are optional.

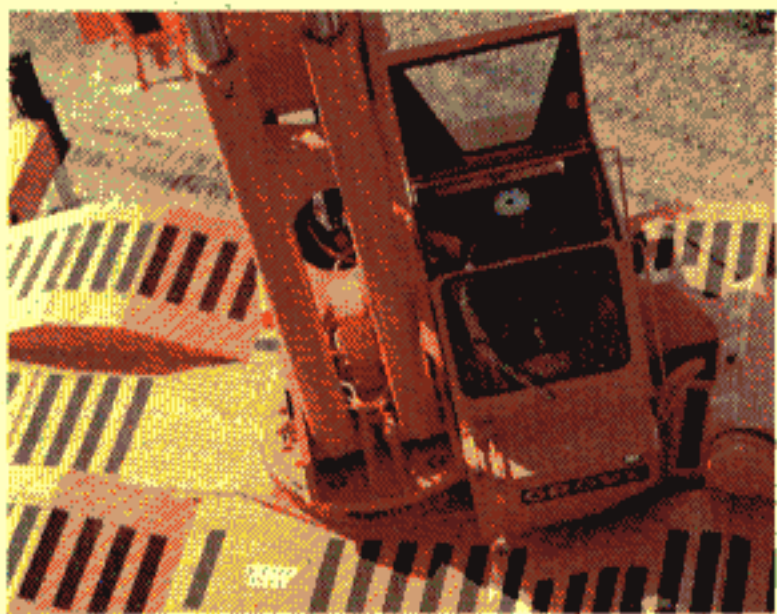

ENGINE SPECIFICATIONS

MAKE & MODEL TYPE	Detroit Diesel 6V-53N 6 cylinder O.H.V.	*Cummins Diesel V555-C200 8 cylinder O.H.V.	*Caterpillar 3208 Diesel 8 cylinder O.H.V.
BORE & STROKE	3.875 in. x 4.50 in. (98mm x 114mm)	4.625 in. x 4.125 in. (117mm x 105mm)	4.5 in. x 5.0 in. (114mm x 127mm)
DISPLACEMENT	318 cu. in. (5212cm ³)	555 cu. in. (9096cm ³)	636 cu. in. (10 424cm ³)
HORSEPOWER (NET)	170 @ 2500 RPM	180 @ 2600 RPM	178 @ 2600 RPM
GOVERNED RPM	2500	2600	2600
TORQUE (NET)	392 lbs. ft. (54kg.m) @ 1500 RPM	380 lbs. ft. (53kg.m) @ 1850 RPM	468 lbs. ft. (65kg.m) @ 1200 RPM
ELECTRICAL SYSTEM	12-Volt, Negative Ground	12-Volt, Negative Ground	12-Volt, Negative Ground
STARTING SYTEM	12-Volt	12-Volt	12 Volt
COMBUSTION SYSTEM	2 Cycle, with blower	4 Cycle, Naturally Aspirated	4 Cycle, Naturally Aspirated
COOLING SYSTEM	Liquid	Liquid	Liquid
FUEL CAPACITY	60 gallons (227 Liters)	60 gallons (227 Liters)	60 gallons (227 Liters)
ALTERNATOR	65 Amp, 12-volt	58 Amp, 12-volt	55 Amp, 12-volt
BATTERY	• (2) 12-volt 825 CCA @ 0°F	• (2) 12-volt 825 CCA @ 0°F	• (2) 12-volt 825 CCA @ 0°F
AIR CLEANER	Dry Type	Dry Type	Dry Type
AIR COMPRESSOR	7.25 CFM	13.2 CFM	12 CFM
HOURMETER	Yes	Yes	Yes

• CCA = Cold cranking amperage per battery

*Denotes Optional Equipment

AXLE WEIGHT DISTRIBUTION CHART

ITEM	POUNDS			KILOGRAMS		
	GROSS	FRONT	REAR	GROSS	FRONT	REAR
Basic standard machine to include: 33 ft. - 112 ft. (10.0-33.9m) 3-section trapezoidal main boom; 32 ft. (9.8m) swingaway section; Grove HO30B-16 main hoist with 450 ft. (137.2m) of 3/4 in. (19mm) diameter rope; GM6V-53N engine; • 9,000 lb. (4082kg) counterweight; 21.00x25-24PR tires	75,476	34,910	40,566	34,236	15,835	18,401
ADD:						
Auxiliary boom nose	+200	+569	-369	+91	+258	-167
24 ft. (7.3m) A-frame jib (stowed)	+907	+897	+10	+411	+407	+4
40 ton (36mt) hookblock	+915	+1,495	-580	+415	+678	-263
•• Grove HO15H-16B auxiliary hoist with 400 ft. (121.9m) of 5/8 in. (16mm) rope	+364	-177	+541	+165	-80	+245
•• Gearmatic Model 25 auxiliary hoist with 400 ft. (121.9m) of 5/8 in. (16mm) rope	+406	-187	+593	+184	-85	+269
••• Grove Model HO30B-16 auxiliary hoist with 400 ft. (121.9m) of 3/4 in. (19mm) rope	+483	-259	+742	+219	-117	+336
SUBSTITUTE:						
34 ft. - 104 ft. (10.3 - 41.4m) 4-section trapezoidal main boom	+2,700	+4,297	-1,597	+1,225	+1,949	-724
Cummins V555-C200 engine	+170	-45	+215	+77	-20	+98
Cat 3208 engine	-128	+34	-162	-58	+15	-73
26.5x25-26PR tires	+1,000	+500	+500	+454	+227	+227
29.5x25-22PR tires	+2,334	+1,167	+1,167	+1,058	+529	+529
29.5X25-28PR tires	+2,734	+1,367	+1,367	+1,240	+620	+620
REMOVE:						
Grove HO30B-16 main hoist with 450 ft. (137.2m) of 3/4 in. (19mm) diameter rope	-2,272	+665	-2,937	-1,030	+302	-1,332
32 ft. (9.8m) swingaway section	-1,937	-2,819	+882	-879	-1,279	+400
33 ft. - 112 ft. (10.0 - 33.9m) 3-section trapezoidal boom	-14,829	-18,925	+4,096	-6,726	-8,584	+1,858
33 ft. - 112 ft. (10.0 - 33.9m) 3-section trapezoidal boom & lift cylinders	-16,671	-20,693	+4,022	-7,562	-9,386	+1,824
Outrigger beams and jacks (front)	-2,637	-3,630	+993	-1,196	-1,646	+450
Outrigger beams and jacks (rear)	-2,637	+1,204	-3,841	-1,196	-1,646	+450
9,000 lb. (4,082kg) counterweight	-9,000	+4,080	-13,080	-4,082	+1,851	-5,933

NOTE: Appropriate counterweight substitutions must be made depending on main and auxiliary hoist configuration specified.

- 9,000 lb. (4082kg) counterweight used with HO30B-16 main hoist only.
- 8,350 lb. (3788kg) counterweight used with HO30B-16 main hoist and HO15H-16B or Gearmatic Model 25 auxiliary hoist.
- 7,250 lb. (3289kg) counterweight used with HO30B-16 main and auxiliary hoists.