

# GROVE® RT65S

SELF-PROPELLED  
**HYDRAULIC  
CRANE with  
TRAPEZOIDAL†  
BOOM**

**35** TON  
CAPACITY

30-TONS METRIC

Meets requirements of P.C.S.A. Standard No. 2

† Patented Grove Feature

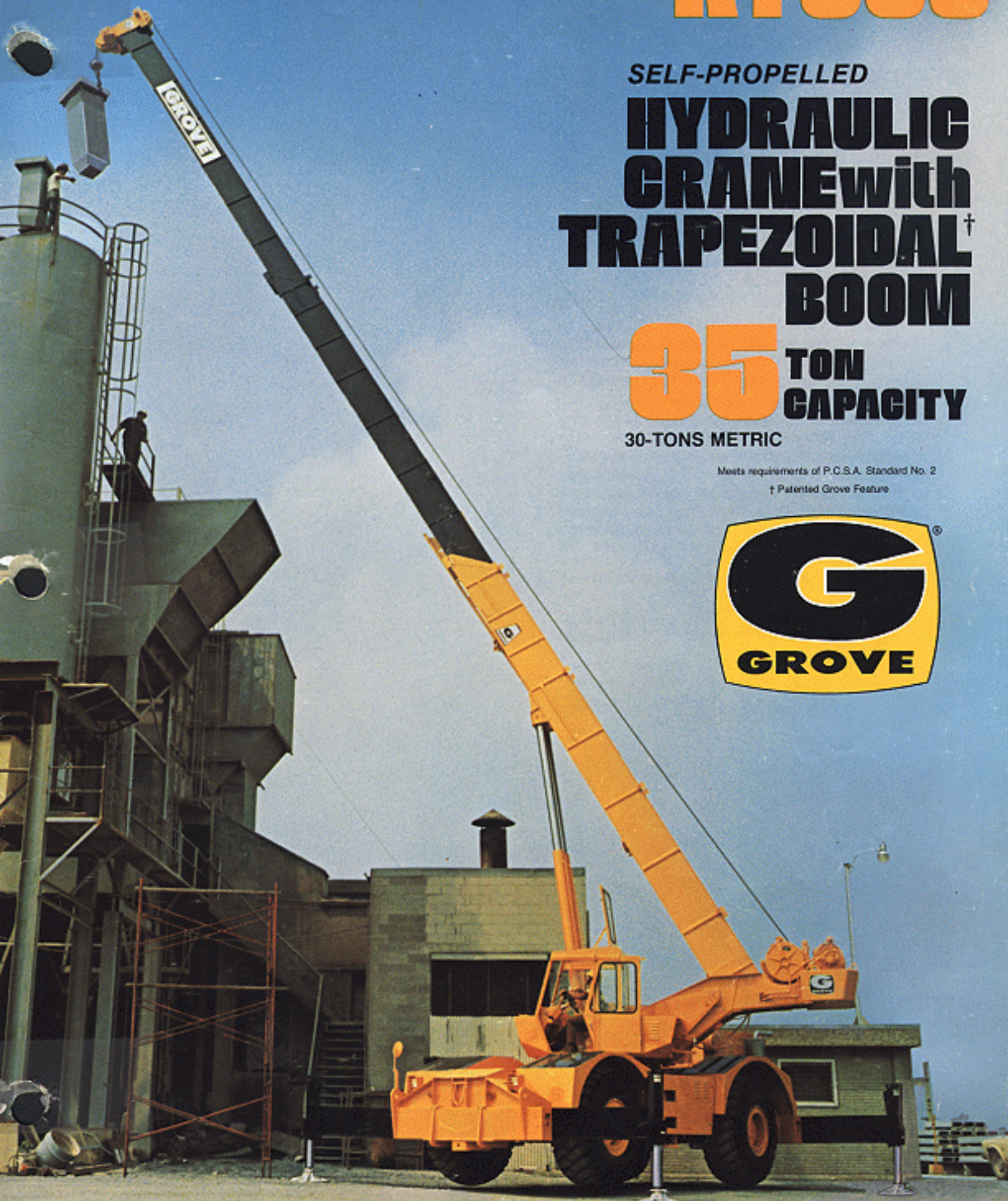

# THE GROVE<sup>®</sup> TRAPEZOIDAL<sup>†</sup> BOOM

A LONG  
REACH BOOM OF  
SUPERIOR STRENGTH  
AND CAPACITY

The Grove Trapezoidal Boom, a major engineering accomplishment in telescoping hydraulic boom design, represents the optimum strength-to-weight ratio for hydraulic crane operation. Compared to conventional booms, the Trapezoidal boom provides greater reach and tons greater capacity at full boom and at any working radii. The superior strength and rigidity are directly attributable to the trapezoidal design and the use of very high strength steels. This permits a deeper, wider and lighter boom with greater resistance to lateral and vertical deflection.

## "SWINGAWAY" LATTICE BOOM EXTENSION

The "Swingaway" lattice boom extension for the RT65S stows laterally along-side the boom base section and swings quickly into working position.

<sup>†</sup> Patented Grove Feature





# SPECIFICATIONS

**BOOM** – 33 ft. – 112 ft. (10.06m x 34.14m), 4-section boom; 2 full power trapezoidal sections to 80 ft. (24.38m) plus a 32 ft. (9.75m) "Swingaway" lattice extension. Integral check valves on each telescoping cylinder.  
 \*34 ft. – 136 ft. (10.36m x 41.45m), 5-section boom; 2 full power and 1 power pinned trapezoidal sections to 104 ft. (31.70m) plus a 32 ft. (9.75m) "Swingaway" lattice extension. Integral check valves on each telescoping cylinder.

**BOOM NOSE** – Three sheaves mounted on heavy duty tapered roller bearings. Removable pin type rope guards allow easy reeving. Rope dead ends on each side of the boom nose.

**BOOM ELEVATION** – Dual double-acting hydraulic cylinders with integral holding valves; elevation from -4° to 76°. Combination controls provided for hand or foot operation.

\***LOAD MOMENT AND ANTI-TWO BLOCK SYSTEM (KRUGER)** – Audio-visual warning in combination with Grove control lever lockout of: hoist up, boom telescope out, and boom down functions.

**SWING** – Ball bearing swing circle, 360° continuous rotation, Grove Planetary "Glide Swing" with foot operated disc swing brake, hand operated positive plunger type turntable lock. Swing speed 2.6 RPM. (Non-free swing optional).

**CAB** – Turntable-mounted on vibration and sound-absorbing rubber grommets, full vision, all steel, fully enclosed, acoustically treated, laminated safety glass windows throughout, removable windshield with storage provision, hinged tinted skylight, sliding left side door, sliding right side and rear vent windows. Full length control levers, fully adjustable operator's seat. Full engine instruments and controls. Combination hand and foot throttle. All crane superstructure and outrigger controls, sight leveling bubble, electronic boom angle indicator, propane heater, forced hot air defroster, electric windshield wiper, dome light, dash light, air horn, front cab mounted work lights, door and window locks, 2¾ lb. (1.25kg) dry type fire extinguisher.

**CAB INSTRUMENTATION** – Engine oil pressure gauge, engine water temperature gauge, voltmeter, electric fuel gauge, electric tachometer, air pressure gauge, transmission and torque converter oil temperature gauge.

**OUTRIGGERS** – Hydraulic double-box integral with main frame; telescoping beams, vertical jacks with integral check valves and mechanical spin locks on each vertical jack to secure outrigger jacks at any level. Beams extend to 21 ft. (6.40m) centerline to centerline, retract to 9 ft. 5 in. (2.87m). Independent or simultaneous control in-out-up-and-down. Outrigger controls in operator's cab. Sequence control arrangement eliminates accidental actuation. 24 in. dia. (610mm) aluminum floats with storage racks.

**MAIN FRAME** – All welded construction with full depth longitudinals braced by cross-members. Frame reinforced at critical points to insure a rigid turntable mounting. Front and rear lifting, towing, and tie down lugs are integral with the main frame.

**TRANSMISSION AND TORQUE CONVERTER** – Engine mounted converter, 1.82:1 stall ration with PTO for hydraulic pumps. Remote mounted full powershift transmission with rear axle disconnect.

**SPEEDS** – 6 forward and 6 reverse.

**AXLES** – Front: Planetary drive with dual steering cylinders mounted rigid to frame.

Rear: Planetary drive with dual steering cylinders mounted to allow 0 in. to 10 in. (254mm) oscillation.

**OSCILLATION LOCKOUTS** – Automatic hydraulic on rear axle. Allows oscillation only with boom over front.

**SERVICE BRAKES** – Full air on all four wheels. Size: 20 in. x 5 in. (508mm x 127mm) with 36 sq. in. (232cm<sup>2</sup>) chambers.

**PARKING BRAKES** – Front and rear axles equipped with "Fail Safe" spring set emergency and parking chambers.

**STEERING** – Front: Power assist hydraulic control.

Rear: Full hydraulic, tiller bar control. Independent front and rear steer control allows maximum "On the Move" maneuverability.

**TIRES** – 21:00 x 25 – 24 ply earth-mover type, tubeless.

\*26.5 x 25 – 26 ply wide base; earth-mover type, tubeless.

\*29.5 x 25 – 22 ply wide base; earth-mover type, tubeless.

**HYDRAULIC SYSTEM:**

**RESERVOIR** – 133 gallon (503 liter) capacity, all steel welded construction with integral baffles, clean-out access and exterior oil sight level.

**FILTER** – Full flow return line replaceable cartridge with by-pass protection and filter by-pass indicator. 25 Micron rating.

**PUMPS** – 4 main gear pumps, 146 GPM capacity (553 lpm). Power steering pump 18.7 GPM capacity (71 lpm). Pump disconnect lever operated from carrier deck.

**CONTROL VALVES** – Precision four-way double-acting with integral load check, main and circuit relief valves. Four individual valve banks permitting simultaneous independent control of four crane functions. Maximum operation pressure 2500 PSI (175.8kg/cm<sup>2</sup>).

**AIR COOLER** – Full flow, fin and tube, oil to air.

**POWER DISTRIBUTION** – (main hoist) (Boom elevation, mid telescope, main hoist boost, \*auxiliary hoist) (Fly telescope, rear steer, boom elevation boost) (Swing).

**MISCELLANEOUS STANDARD EQUIPMENT** – Complete light package, tool box and storagewell, fenders, hook-block tie down, ether injection cold starting aid, chassis mounted rear view mirror.

\*Denotes optional equipment

## HOIST SPECIFICATIONS

DESCRIPTION: Series parallel circuitry and two motors provide both high line pull and speed ranges. Power up and down, equal speed, planetary reduction with integral automatic brake.		DESCRIPTION: Power up and down, equal speed, planetary reduction with integral automatic brake.	
HOIST DATA	MAIN HOIST Grove Model 32S-1716A	*AUXILIARY HOIST Grove Model 15S-16A	*AUXILIARY HOIST (FREE FALL) Model 40 SGEGR
Drum Dimensions	16 in. dia. (406mm) 16 in. length (406mm) 24 in. dia. flange (610mm)	12 in. dia. (305mm) 16 in. length (406mm) 17.5 in. dia. flange (445mm)	9 in. dia. (229mm) 13 in. length (330mm) 17.5 in. dia. flange (445mm)
Performance: Max. Single Line Speed Max. Single Line Pull	<b>Hi-Speed Range</b> 525 FPM (160m/min) 8,400 lbs. (3810kg) <b>Lo-Speed Range</b> 265 FPM (80.8m/min) 16,800 lbs. (7620kg)	200 FPM (61m/min) 9165 lbs. (4157kg)	290 FPM (88.4m/min) 9,145 lbs. (4148kg)
Drum Rope Storage Capacity	▲650 ft. of ¾ in. dia. rope (198.1m of 19mm)	720 ft. of ½ in. dia. rope (219.5m of 13mm) 480 ft. of ⅝ in. dia. rope (146.3m of 16mm) <sup>1</sup>	675 ft. of ½ in. dia. rope (205.7m of 13mm)
Permissible Single Line Rope Pull	¾ in. (19mm) 6x41 class - 14,605 lbs. (6625kg) ¾ in. (19mm) 19x7 class - 13,700 lbs. (6214kg)	½ in. (13mm) 19x7 class - 6,150 lbs. (2790kg) ½ in. (13mm) 6x37 class - 7,200 lbs. (3266kg) ⅝ in. (16mm) 19x7 or 6x41 class - 7,680 lbs. (3484kg)	½ in. (13mm) 19x7 class - 6,150 lbs. (2790kg) ½ in. (13mm) 6x37 class - 7,200 lbs. (3266kg)

\*Denotes Optional Equipment

▲ 6th layer of rope not recommended for hoisting operations



# SPECIFICATIONS

## ENGINE SPECIFICATIONS

MAKE & MODEL	Detroit Diesel 6V-53N	*Cummins Diesel V555-C200	*Caterpillar 3208 Diesel
TYPE	6 Cylinder O.H.V.	8 Cylinder O.H.V.	8 Cylinder O.H.V.
BORE & STROKE	3.875 in. x 4.50 in. (98mm x 114mm)	4.625 in. x 4.125 in. (117mm x 105mm)	4.5 in. x 5.0 in. (114mm x 127mm)
DISPLACEMENT	318 cu.in. (5212cm <sup>3</sup> )	555 cu.in. (9096cm <sup>3</sup> )	636 cu.in. (10424cm <sup>3</sup> )
HORSEPOWER (NET)	173 @ 2500 RPM	176 @ 2600 RPM	178 @ 2600 RPM
GOVERNED RPM	2500	2600	2600
TORQUE (NET)	396 lbs. ft. @ 1500 RPM	391 lbs. ft. @ 1800 RPM	468 lbs. ft. @ 1200 RPM
ELECTRICAL SYSTEM	12-Volt, Negative Ground	12-Volt, Negative Ground	12-Volt, Negative Ground
COMBUSTION SYSTEM	2 Cycle with blower,	4 Cycle, Naturally Aspirated	4 Cycle, Naturally Aspirated
COOLING SYSTEM	Liquid	Liquid	Liquid
FUEL CAPACITY	60 Gallon (227 Liters)	60 Gallon (227 Liters)	60 Gallon (227 Liters)
ALTERNATOR	60 Amp, 12-volt	58 Amp, 12-volt	55 Amp, 12-volt
BATTERY	(2) 204 A.H., 12-volt	(2) 204 A.H., 12-volt	(2) 204 A.H., 12-volt
AIR CLEANER	Dry Type	Dry Type	Dry Type
AIR COMPRESSOR	7.25 CFM	13.2 CFM	12 CFM
HOURLY METER	Yes	Yes	Yes

\*Denotes Optional Equipment

## SPEED AND GRADEABILITY

Forward Drive	Transmission Range	Gear Shift	Maximum Speed		Gradeability @ Stall (%)	Tractive Effort At Stall	
			MPH	KM/H		LBS.	KGS.
4 Wheel Drive	Low	1st	2.1	3	72.8	45,033	20 427
4 Wheel Drive	Low	2nd	3.9	6	32.1	23,791	10 792
4 Wheel Drive	Low	3rd	10.0	16	9.9	8,706	3 949
2 Wheel Drive	High	1st	4.8	8	24.7	18,907	8 576
2 Wheel Drive	High	2nd	8.8	14	11.8	10,003	4 537
2 Wheel Drive	High	3rd	21.8	35	2.9	3,658	1 659

NOTE: All performance data is based on standard machine and may vary plus or minus 10% due to variations in engine performance.

## WORKING WEIGHTS

Standard Machine With	Total Weight		Axle Weight Distribution			
	Lbs.	Kg.	Front		Rear	
			Lbs.	Kg.	Lbs.	Kg.
33-112 Boom (10.06m - 34.14m)	67,250	30 504	34,178	15 503	33,072	15 001
34-136 Boom (10.36m - 41.45m)	69,290	31 429	37,697	17 099	31,593	14 330

## DIMENSIONS

TIRE SIZE	"A"	"B"	"C"	"D"	"E"	"F"
21.00 x 25	70 in. (1.78m)	96½ in. (2.45m)	10 ft. 3 in. (3.12m)	31 in. (787mm)	12 in. (305mm)	19 in. (483mm)
26.5 x 25	67 in. (1.70m)	97½ in. (2.48m)	10 ft. 8 in. (3.25m)	31 in. (787mm)	12¼ in. (311mm)	19 in. (483mm)
29.5 x 25	66 in. (1.68m)	98½ in. (2.50m)	10 ft. 11 in. (3.33m)	33 in. (838mm)	14¼ in. (362mm)	21 in. (533mm)

BOOM LENGTH	"G"	"H"
*33 ft. - 80 ft. (10.06m - 24.38m)	15 ft. 6 in. (4.72m)	41 ft. 2 in. (12.55m)
*34 ft. - 104 ft. (10.36m - 31.70m)	16 ft. 6 in. (5.03m)	42 ft. 2½ in. (12.85m)

\*32 foot (9.75m) extension stowed

FENDER WIDTH - 10 ft. 11 in. (3.33m)

TAIL SWING - 13 ft. 6 in. (4.11m)

TURNING RADIUS - 23 ft. 4 in. (7.11m)

OVERALL HEIGHT WITH STANDARD TIRES 11 ft. 10 in. (3.61m)

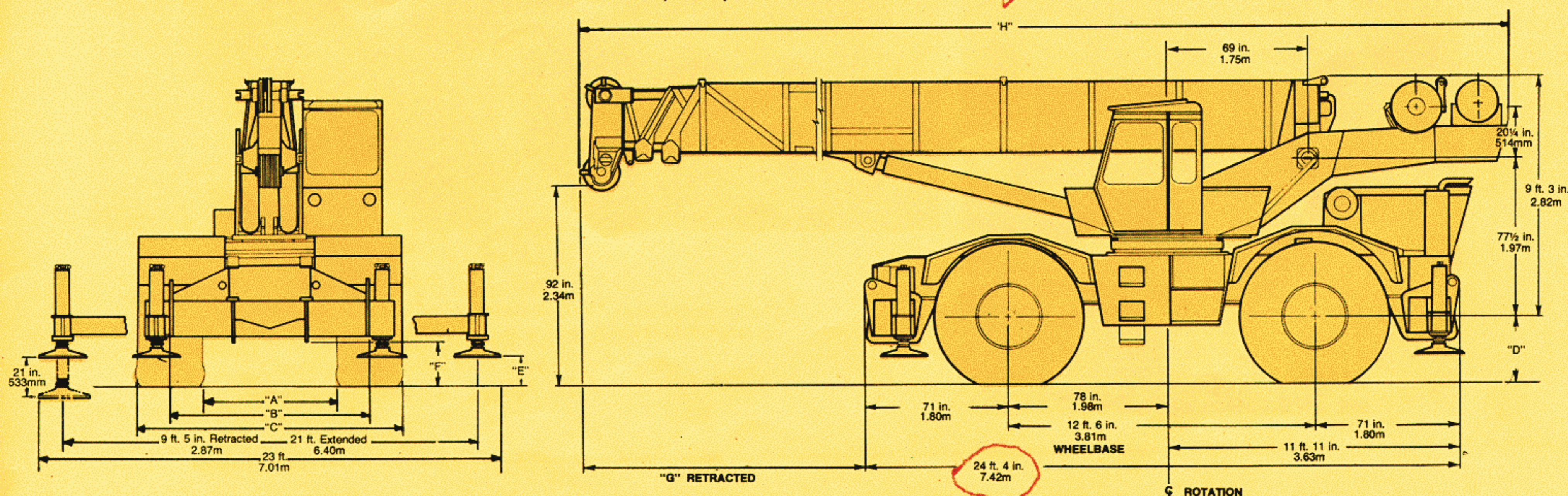

Constant improvement and engineering progress make it necessary that we reserve the right to make specification, equipment, and price changes without notice.

# FEATURES

**TWO SPEED HOIST†** . . . a Grove innovation which permits both high line pull and high line speed without changes in lagging or gearing. At the flick of the electropneumatic speedshift, the operator can change from maximum single line pull of 16,800 lbs. (7620kg) to top single line speed of 525 fpm (160.02m/min).

**EXCLUSIVE GROVE SCREW-LOCK†** permits the outrigger jacks to be locked in any position. Long thrust vertical jacks assure quick easy leveling on rough terrain. Jacks are fitted with integral check valves. Outriggers are of the double-box beam type and provide a spread of 21 feet (6.40m). Light weight aluminum floats are stored in compartments on each side of the chassis.

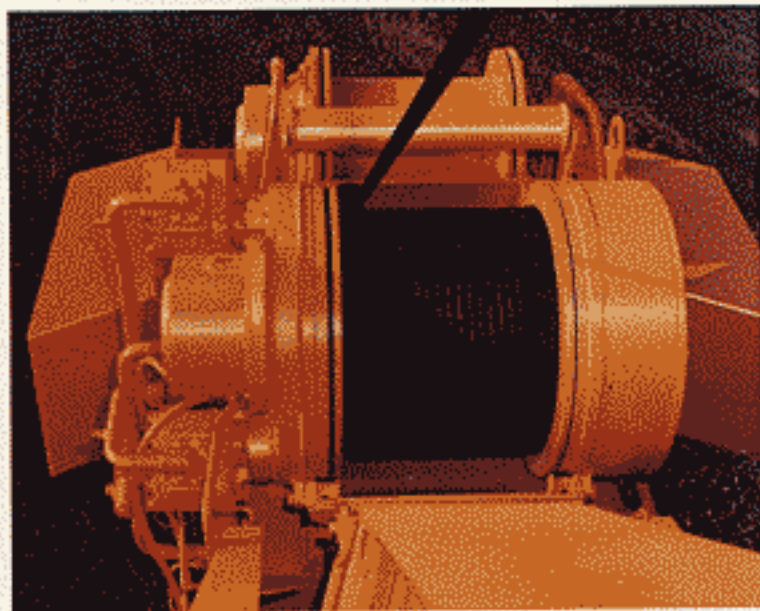

**CAB PROVIDES HIGH VISIBILITY AND CONVENIENCE . . .** The turntable mounted cab faces the operator towards the load at all times and controls are conveniently arranged to assure maximum ease in performing all crane functions. When the skylight is raised and the windshield removed, there is no overhead cross-member to interfere with the operator's view of the load.

**EASIER REEVING . . .** removable pin-type rope guards and negative boom angle permit quick and easy ground level reeving and work on hook block.

## OTHER FEATURES

**ALL-WELDED FRAME** of box-beam construction with full depth longitudinals, braced by cross-members and with integral outrigger boxes assures a strong rigid lifting platform.

**THE LOAD MOMENT AND ANTI-TWO BLOCK SYSTEM (optional)** measures critical operational factors relative to rated capacity and gives the operator a continuous visual display of conditions for the load.

An easy-to-read gauge indicates the approach of an overload or two-block condition and should overload or two-block occur, an audio-visual warning alerts the operator; the Grove "control lever lockout system" returns the control levers to neutral and permits the use of only those crane functions that will correct the condition.

**TOOL STORAGE** is provided in a large storage compartment located forward on the chassis.



† The Trapezoidal Boom, Two Speed Hoist, and Vertical Jack Lock are patented Grove features.