

RT620S SPECIFICATIONS



ENGINE SPECIFICATIONS

MAKE & MODEL	Cummins Diesel V-504C	*Detroit Diesel 4-53N	*Caterpillar Diesel 3208
TYPE	8 Cylinder OHV	4 Cylinder OHV	8 Cylinder OHV
BORE & STROKE	4.625 in. x 3.75 in. (117mm x 95mm)	3.875 in. x 4.50 in. (98mm x 114mm)	4.5 in. x 5.0 in. (114mm x 130mm)
DISPLACEMENT	504 cu. in. (8259cm ³)	212 cu. in. (3474cm ³)	636 cu. in. (10 422cm ³)
HORSEPOWER (NET)	142 @ 2600 RPM	109 @ 2800 RPM	122 @ 2500 RPM
GOVERNED RPM	2600 RPM	2800 RPM	2500 RPM
TORQUE (NET)	303 lbs. ft. (42kg.m) @ 1800 RPM	236 lbs. ft. (33kg.m) @ 1800 RPM	344 lbs. ft. (48kg.m) @ 1100 RPM
ELECTRICAL SYSTEM	12-volt, Negative Ground	12-volt, Negative Ground	12-volt, Negative Ground
COMBUSTION SYSTEM	4 Cycle, Naturally Aspirated	2 Cycle, w/blower	4 Cycle, Naturally Aspirated
COOLING SYSTEM	Liquid	Liquid	Liquid
FUEL CAPACITY	50 Gallons (189 liters)	50 Gallons (189 liters)	50 Gallons (189 liters)
ALTERNATOR	55 Amp, 12-volt	65 Amp, 12-volt	55 Amp, 12-volt
BATTERY	(2) 12-volt 1500 CCA @ 0°F	(1) 12-volt 825 CCA @ 0°F	(2) 12-volt 1500 CCA @ 0°F
AIR CLEANER	Dry Type	Dry Type	Dry Type
AIR COMPRESSOR	13.2 CFM (374 lpm)	7.25 CFM (205 lpm)	12 CFM (340 lpm)
HOURLY METER	Yes	Yes	Yes

*Denotes optional equipment

SPEED AND GRADEABILITY

Forward Drive	Transmission Range	Gear Shift	Maximum Speed		Max. Gradeability @ Stall %	Max. Tractive Effort At Stall	
			MPH	KM/H		LB.	KG.
4 Wheel Drive	Low	1st	2.7	4.3	87.3	32,515	14 749
4 Wheel Drive	Low	2nd	5.1	8.2	35.9	17,176	7791
4 Wheel Drive	Low	3rd	13.8	22.2	11.2	6,292	2854
2 Wheel Drive	High	1st	6.4	10.3	27.5	13,672	6202
2 Wheel Drive	High	2nd	12.1	19.5	13.1	7,210	3270
2 Wheel Drive	High	3rd	28.5	45.9	3.5	2,652	1203

NOTE: All performance data is based on standard machine and may vary plus or minus 10% due to variations in engine performance and vehicle weight.

WORKING WEIGHTS

Standard Machine With	Total Weight		Axle Weight Distribution			
	Lbs.	Kg.	Front		Rear	
			Lbs.	Kg.	Lbs.	Kg.
28-70 ft. (8.5m - 22.3m) boom	47,980	21 764	28,620	12 982	19,360	8782
*24-60 ft. (7.3m - 18.3m) boom	46,820	21 238	24,160	10 959	22,660	10 279
*24-78 ft. (7.3m - 23.7m) boom	48,425	21 966	27,400	12 429	21,025	9537

NOTE: Weights may vary plus or minus 3% due to manufacturing tolerances.

*Denotes optional equipment.

DIMENSIONS

TIRE SIZE	A	B	C	D	E	F ₁	F ₂
16:00 x 24	59 3/8 in. (1508mm)	77 1/2 in. (1969mm)	95 5/8 in. (2429mm)	13 1/2 in. (343mm)	26 in. (660mm)	23°	19°
*20.5 x 25	59 3/8 in. (1502mm)	81 1/8 in. (2061mm)	103 1/8 in. (2619mm)	14 1/4 in. (362mm)	26 13/16 in. (681mm)	21°	18°

*Denotes optional equipment

BOOM LENGTH	G	H	I
*24-60 ft. (7.3m - 18.3m)	11 ft. 2 1/2 in. (3416mm)	31 ft. 6 5/8 in. (9617mm)	8 ft. 8 1/4 in. (2648mm)
28-70 ft. (8.5m - 21.3m)	15 ft. 2 1/2 in. (4636mm)	35 ft. 6 5/8 in. (10 836mm)	8 ft. 9 5/16 in. (2675mm)
*24-78 ft. (7.3m - 23.7m)	11 ft. 1/4 in. (3359mm)	31 ft. 4 5/16 in. (9558mm)	8 ft. 8 1/4 in. (2648mm)

Tail Swing - 10 ft. 3 3/4 in. (3131mm)
Turning Radius - 15 ft. 10 in. (4826mm)

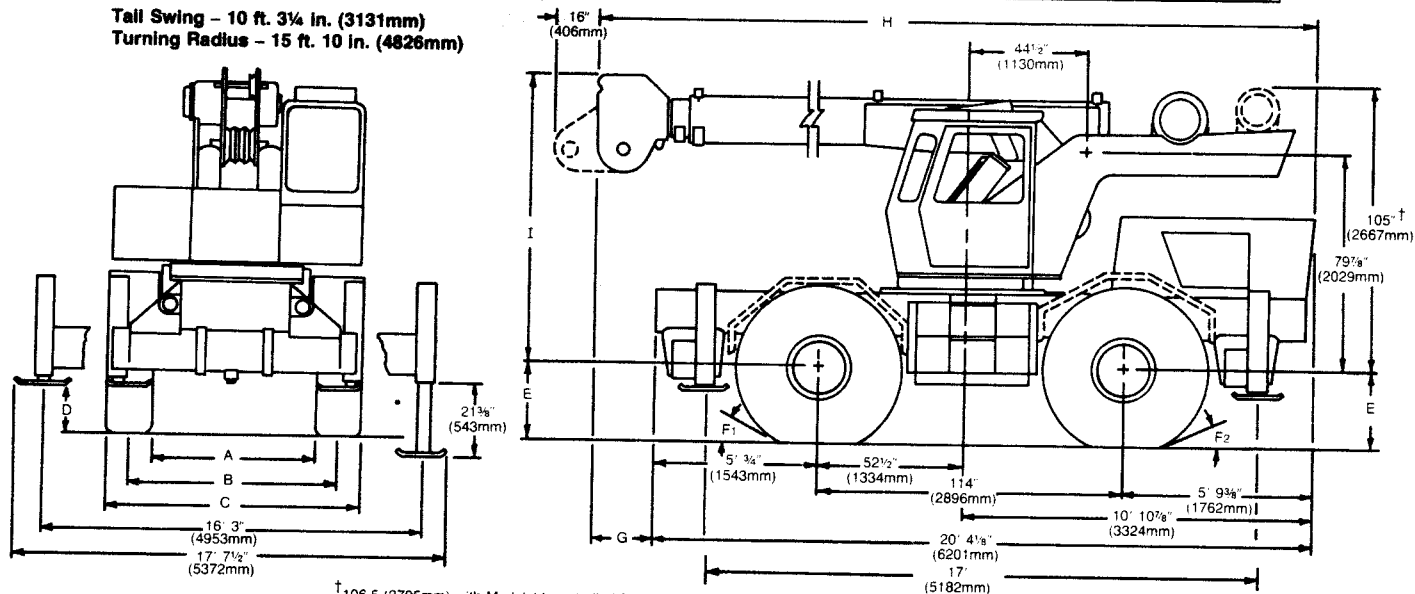

†106.5 (2705mm) with Model 11 controlled free fall hoist as auxiliary.



RT620S SPECIFICATIONS

BOOM – 28 ft. – 70 ft. (8.5m – 21.3m), 3 section, full power telescoping *24 ft. – 60 ft. (7.3m – 18.3m), 3 section, full power telescoping. *24 ft. – 78 ft. (7.3m – 23.8m), 4 section, power telescoping. Two full power sections to 60 ft. (18.3m) plus an 18' (5.5m) fly section power extended and retracted from pinned position. Pendulum boom angle indicator. Integral holding valves on each telescoping cylinder. Boom telescope sections are individually controlled and supported on graphite impregnated nylon wear pads. Side adjustable wear pads prevent metal-to-metal contact of inner boom sections.

BOOM NOSE – Three 1 1/4" tread dia. (286mm) sheaves mounted on heavy duty needle bearings. Removable pin type rope guards allow easy reeving. Rope dead ends on one side of boom nose. *(Single sheave 1 1/4" tread dia. (286mm) auxiliary boom nose mounted to main boom nose, with removable pin-type rope guard. For single part line work.)

BOOM ELEVATION – Dual 8 1/4" (210mm) bore double-acting cylinders with integral holding valves; 0° to 75° elevation.

***LOAD MOMENT AND ANTI-TWO BLOCK SYSTEM (KRUGER)** – Audio-visual warning in combination with automatic by-pass of: hoist up, boom telescope out, and boom down functions.

***JIBS** – 19 ft. (5.8m) "Stowaway" for 24 ft. – 60 ft. (7.3m – 18.3m) and 24 ft. – 78 ft. (7.3m – 23.8m) booms. 23 ft. (7.0m) "Stowaway" for 28 ft. – 70 ft. (8.5m – 21.3m) boom. All jibs have self-equalizing suspension and jib backstops.

SWING – Ball bearing swing circle, 360° continuous rotation. Grove planetary "Glide Swing" with foot-operated disc swing brake and cab-controlled positive (plunger type) turntable lock. Swing speed 3.1 RPM. (Non-free swing optional)

CAB – Turntable-mounted, full vision, all steel, fully enclosed with tinted, tempered glass throughout and hinged skylight: (windshield laminated). Left side door with lock, side sliding windows with locks. Full length control levers, fully adjustable operator's seat. Complete engine instrumentation and driving controls. Combination hand and foot throttle. All-crane super-structure and outrigger controls, 20,000 BTU diesel fuel heater, electric windshield wiper, domelight, front cab-mounted work lights, defroster fan, air horn, 3 1/2 lb. (1.7kg) dry-type fire extinguisher.

CAB INSTRUMENTATION – Engine oil pressure gauge, engine water temperature gauge, voltmeter, electric fuel gauge, air pressure gauge, transmission and torque converter oil temperature gauge, engine hourmeter, low air pressure visual warning. Hoist rotation indicator.

OUTRIGGERS – Hydraulic, double-box, integral with main frame; telescoping beams, enclosed vertical jacks with integral holding valves and mechanical pin locks. Independent or simultaneous control in-out-up-and-down. Out-rigger controls in operator's cab. Sequence control arrangement virtually eliminates accidental outrigger actuation.

MAIN FRAME – All-welded construction with full depth longitudinals braced by cross-members. Frame reinforced at critical points to insure a rigid turntable mounting.

TRANSMISSION AND TORQUE CONVERTER – Engine-mounted converter with PTO for hydraulic pumps. Remote mounted full powershift transmission with rear axle disconnect.

SPEEDS – 6 forward and 6 reverse.

AXLES – Front: Planetary drive/steer type mounted rigid to frame. Rear: Planetary drive/steer type mounted to allow 0 in. to 9.5 in. (0 – 241mm) oscillation. (No spin rear axle optional.)

OSCILLATION LOCKOUTS – Automatic hydraulic on rear axle. Allows oscillation only with boom over front.

SERVICE BRAKES – Full air on all four wheels. Size: 20 1/4 in. x 4 in. (514mm x 102mm). Total lining area: 644 sq. in. (415cm²).

PARKING BRAKES – Front and rear axles equipped with "Fail Safe" spring set emergency and parking chambers.

STEERING – Front: Full power assist hydraulic control. Rear: Full hydraulic, tiller bar control. Independent front and rear steer control allows maximum "on the move" maneuverability.

TIRES – 16:00 x 24 – 16 ply tubeless, heavy duty grader. *20.5 x 24 – 20 ply tubeless, high flotation earth mover.

***TOW WINCH** – Braden PD15 planetary, front-mounted, cab-controlled with 15,000 lb. (6804kg) single line pull and 145 FPM (44.2mpm) single line speed under full load (less rope and hook).

HYDRAULIC SYSTEM:

RESERVOIR – 82.6 gallon (312.6 liter) capacity, all-steel welded construction with integral baffles, clean out access and sight level gauge.

FILTER – Return line type with replaceable cartridge and by-pass protection 10 micron rating.

PUMPS – 3 main gear pumps, 112.5 GPM (426 lpm) combined capacity. Power steering pump 18.7 GPM (71 lpm) capacity. Pump disconnect lever operated from carrier deck.

CONTROL VALVES – Precision four-way double-acting with integral load check, main and circuit relief valves. Three individual valve banks permitting simultaneous independent control of three crane functions. Maximum operating pressure 2500 PSI. (175.8kg/cm²)

OIL COOLER – Full flow, fin and tube, oil to air.

POWER DISTRIBUTION – [Main hoist, *auxiliary hoist, 46.5 GPM (176 lpm)]; [Boom elevation, rear steer, mid telescope, main hoist boost, 39.5 GPM (149.5 lpm)]; [Fly telescope, outrigger, swing, 26.5 GPM (100.3 lpm)].

MISCELLANEOUS – Front storage well, hydraulic and fuel step tanks, protecto seal fuel cap, right side rear view mirror, full engine hood.

*Denotes optional equipment.

HOIST SPECIFICATIONS

DESCRIPTION: Power up and down, equal speed, planetary reduction with integral automatic brake and hoist drum rotation indicator.			
HOIST DATA	MAIN HOIST Grove Model 15H-16B	*AUXILIARY HOIST Grove Model 15S-11B	*MAIN OR AUXILIARY HOIST Gearmatic Model 11 SGEGR (Controlled Free Fall)
Drum Dimensions	12 in. dia. (305mm) 16 in. length (406mm) 17.5 in. dia. flange (445mm)	12 in. dia. (305mm) 11 in. length (279mm) 17.5 in. dia. flange (445mm)	9 in. dia. (229mm) 13 in. length (330mm) 17.5 in. dia. flange (445mm)
Performance: Max. Single Line Speed Max. Single Line Pull	355 FPM (108m/min) 9,165 lb. (4157kg)	200 FPM (61m/min) 9,165 lb. (4157kg)	290 FPM (88m/min) 9,145 lb. (4148kg)
Drum Rope Storage Capacity	**720 ft. of 1/2 in. dia. rope (219.5m of 13mm)	489 ft. of 1/2 in. dia. rope (149.1m of 13mm)	675 ft. of 1/2 in. dia. rope (206m of 13mm)
Permissible Single Line Rope Pull	1/2 in. (13mm) 6x37 class – 7,200 lb. (3266kg) 1/2 in. (13mm) 19x7 class – 6,150 lb. (2790kg)	1/2 in. (13mm) 6x37 class – 7,200 lb. (3266kg) 1/2 in. (13mm) 19x7 class – 6,150 lb. (2790kg)	1/2 in. (13mm) 6x37 class – 7,200 lb. (3266kg) 1/2 in. (13mm) 19x7 class – 6,150 lb. (2790kg)

*Denotes optional equipment

**6th layer of rope not recommended for hoisting operations.

GROVE®

FULL HYDRAULIC SELF-PROPELLED CRANE

RT6200 20 TON CAP.

RATED LIFTING CAPACITIES

ON OUTRIGGERS FULLY EXTENDED - 360°

ON RUBBER

24 ft. - 60 ft. BOOM

Radius in Feet	Boom Length in Feet						
	24	30	36	42	48	54	60
10	40,000	34,500	32,700	30,800			
12	32,000	32,000	31,000	30,000	28,000		
15	26,000	26,000	26,000	26,000	24,000	22,000	20,000
20	20,000	20,000	20,000	20,000	20,000	19,000	17,500
25		15,000	15,000	15,000	15,000	15,000	15,000
30			11,800	11,800	11,800	11,800	11,800
35				9,100	9,100	9,100	9,100
40					7,100	7,100	7,100
45						5,300	5,300
50						4,100	4,100
55							3,650

A6-829-002161A

PCSA CLASS
(10-71)

Radius in Feet	Over Front	Over Side
10	*30,000	19,500
12	24,600	14,800
15	16,500	9,800
20	11,200	6,350
25	7,200	3,860
30	5,250	2,680
35	3,660	1,650
40	2,780	550
45	2,100	
50	1,420	
55	940	

A6-829-000193A

All On Rubber Capacities are based on 16:00 x 24 tires and 80 PSI inflation pressure. Loads must be reduced for lower inflation pressures.

*For 30,000 lb. lifting capacity, maximum boom length is 42 ft.

28 ft. - 70 ft. BOOM

Radius in Feet	Boom Length in Feet							
	28	34	40	46	52	58	64	70
10	40,000	34,000	31,900	29,800				
12	32,000	31,000	30,000	29,800	27,800			
15	27,500	27,500	27,500	27,500	27,000	25,750	23,700	
20	21,250	21,250	21,000	21,000	20,750	20,500	20,400	20,250
25		15,500	15,500	15,500	15,500	15,500	15,000	15,000
30		11,700	11,700	11,700	11,700	11,700	11,700	11,700
35			8,650	8,650	8,650	8,650	8,650	8,650
40				6,650	6,650	6,650	6,650	6,650
45					5,250	5,250	5,250	5,250
50						4,250	4,250	4,250
55							3,460	3,460
60							2,760	2,760
65								2,180
66.5								1,970

A6-829-002162A

PCSA CLASS
(10-67)

Radius in Feet	Over Front	Over Side
10	30,000 (a)	19,500 (b)
12	24,500 (b)	14,800 (c)
15	16,600 (c)	9,800 (d)
20	10,300 (e)	5,450 (e)
25	6,650	3,660
30	4,850	2,300
35	3,380	1,330
40	2,680	470
45	1,525	
50	950	
55	635	

A6-829-000197(4)

Maximum Permissible Boom Length:
(a) 28 ft.
(b) 34 ft.
(c) 46 ft.
(d) 52 ft.
(e) 64 ft.

24 ft. - 78 ft. BOOM

Radius in Feet	Boom Length in Feet						
	24	30	36	42	48	54	60
10	40,000	34,500	32,700	30,800			
12	32,000	32,000	31,000	29,900	28,000		
15	26,000	26,000	26,000	25,500	24,000	22,000	20,000
20	20,000	20,000	20,000	20,000	20,000	19,000	17,500
25		13,000	13,000	13,000	13,000	13,000	13,000
30			10,800	10,800	10,800	10,800	10,800
35				8,200	8,200	8,200	8,200
40					6,100	6,100	6,400
45						4,300	4,500
50						2,800	3,200
60							1,600
65							1,300
70							1,300
74.8							1,175

A6-829-002163A

PCSA CLASS
(10-61)

Radius in Feet	Over Front	Over Side
10	30,000 (a)	18,000 (c)
12	24,500 (b)	13,500 (d)
15	16,500 (d)	8,000
20	9,500	4,500
25	6,400	2,900
30	4,250	1,200
35	2,675	600
40	1,500	350
45	950	
50	560	

A6-829-000201B

Use of manual fly section not recommended for on rubber lifting.

Maximum Permissible Boom Length:
(a) 24 ft.
(b) 30 ft.
(c) 36 ft.
(d) 48 ft.

NOTE: Capacities do not exceed 85% of tipping loads as determined by test in accordance with SAE recommended practice - Crane Load Stability Test Code - SAE J-765.

Capacities appearing in shaded area are based upon structural strength and machine stability should not be relied upon as the capacity limitation.
**Indicates maximum capacity of Extended Fly Section, regardless of boom length.

NOTES TO LIFTING CAPACITIES, SEE REVERSE SIDE

RANGE DIAGRAM 24 ft. - 60 ft. BOOM

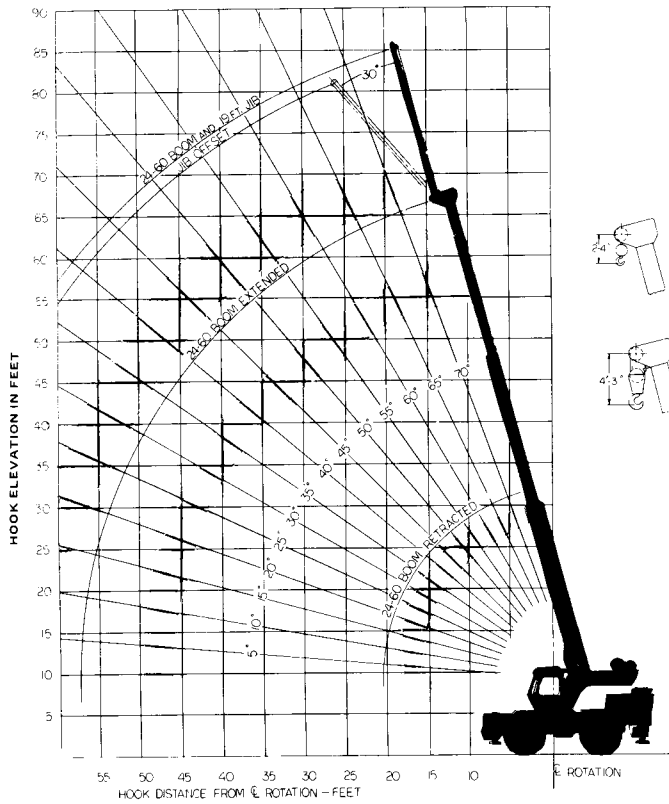

19 ft. JIB

MIN. BOOM ANGLE	NO OFFSET	MAX. OFFSET (30°)
75	6200	2600
70	5000	2400
65	4300	2300
60	3700	2150
55	3300	2100
50	2600	1650
45	2400	1500
40	2200	1460
30	1900	1200

A6-829-000194B

JIB CAPACITIES

23 ft. JIB

MIN. BOOM ANGLE	NO OFFSET	MAX. OFFSET (26°)
75	6400	3100
70	5150	2850
65	4350	2650
60	3700	2450
55	3300	2275
50	2950	2170
45	2650	2125
40	2550	2085
35	2475	2040
30	2400	2000
26	2300	1950

A6-829-000583C

NOTES TO LIFTING CAPACITIES

- Do not exceed any rated lifting capacity. Rated lifting capacities are based on freely suspended loads with the machine leveled and standing on a firm supporting surface. Ratings with outriggers are based on outriggers being extended to their maximum position and tires raised free of crane weight before extending the boom or lifting loads.
- Practical working loads for each particular job shall be established by the user depending on operating condition to include: the supporting surface, wind and other factors affecting stability, hazardous surroundings, experience of personnel, handling of load, etc. No attempt must be made to move a load horizontally on the ground in any direction.
- Operating radius is the horizontal distance from the axis of rotation before loading to the centerline of the vertical hoist line or tackle with loads applied.
- "On Rubber" lifting (if permitted) depends on proper tire inflation, capacity and condition. "On Rubber" loads may be transported at a maximum vehicle speed of 2.5 mi/hr (4 Km/hr) on a firm and level surface under conditions specified.
- Jibs may be used for single line lifting crane service only. Jib capacities are based on structural strength of jib or main boom. Jib loads must not exceed main boom lifting capacities for the actual operating radius.
- Operation is not intended or approved for any conditions outside of those shown hereon. Handling of personnel from the boom is not authorized except with equipment furnished and installed by Grove Manufacturing Company.
- For clamshell or concrete bucket operation, weight of bucket and load must not exceed 80% of rated lifting capacities.
- Power-telescoping boom sections must be extended equally at all times. Long cantilever booms can create a tipping condition when in extended and lowered position.
- The maximum load which may be telescoped is limited by hydraulic pressure, boom angle, boom lubrication, etc. It is safe to attempt to telescope any load within the limits of rated lifting capacity chart.
- With certain boom and hoist tackle combinations, maximum capacities may not be obtainable with standard cable lengths.
- With certain boom and load combinations, raising of load with boom lift cylinders may not be possible. Operational safety is not affected by this condition.
- Keep load handling devices a minimum of 12 inches (30 cm) below boom head when lowering or extending boom.
- If actual boom length and/or radius is between values listed, use lifting capacity for the next longer rated length and/or radius.
- All load handling devices and boom attachments are considered part of the load and suitable allowances must be made for their combined weights.
- Operation of this equipment in excess of rating charts or disregard of the instructions is hazardous and voids the warranty and manufacturer's liability.

Distributed by:



GROVE MANUFACTURING COMPANY

Division of Walter Kidde & Company, Inc.

KIDDE

Box 21, Shady Grove, Pennsylvania 17256

Printed in U.S.A.