



RT525B

Rough Terrain Hydraulic Crane/Capacity 25 Tons

SUPERSTRUCTURE SPECIFICATIONS

ANTI-TWO BLOCK SYSTEMS (KRUEGER "A2B", *"HAP" & *"HLAP")

- Basic "A2B" is an audio-visual (light/buzzer) warning system to alert operator to an impending two block condition. Hookblock or headache ball coming in contact with weight suspended from boom nose switch activates the audio-visual warning system on the display panel located within easy view of operator. *Optional to the basic "A2B" systems are Krueger "HAP" and "HLAP" anti-two block system. *HAP is the same as the basic system but further incorporates electronic boom angle display with low and high angle presets. *HLAP is the same as HAP but further incorporates selective electronic in-cab display of boom length in feet and meters. An additional option available to all anti-two block systems is Grove control lever lockout of: hoist up, telescope out and boom down crane function.

*LOAD MOMENT & ANTI-TWO BLOCK SYSTEM (KRUEGER "LMI")

- A load moment indicating and anti-two block system with audio-visual warning and control lever lock-out of: hoist up, telescope out and boom down crane functions. Dash mounted console displays relative load moment and also provides operator with selective electronic display of boom length and load radius in feet and meters and boom angle in degrees. Angle indicator has high and low "presets" with audio-visual warning system.

CAB - One-man turntable-mounted, fully enclosed with: tinted safety glass throughout, hinged skylight, sliding left side door and sliding right side window for ventilation, outrigger level indicator, windshield wiper, horn, door and

window locks, domelight, dashlight, 2-3/4 lbs. (1.25 kg) dry type fire extinguisher. Optional are: windshield washer, diesel or propane heaters with hot air defroster, manual skylight wiper, sound suppression, tachometer, seat belt, spotlight.

CONTROLS - Dash-mounted, hand-operated levers for swing, boom telescope, rear steer, boom elevation, *auxiliary hoist and main hoist. Foot-operated controls consist of swing brake, boom elevation, service brakes and engine throttle. Right hand console includes transmission gear selection, high-low range selection, engine hand throttle, outrigger controls, emergency parking brake, *heater controls, console panel light, engine start/stop.

INSTRUMENTATION - Engine oil pressure and water temperature (except Deutz Diesel), voltmeter, transmission/converter oil temperature and electric fuel gauge.

*Emergency steer indicator, *rear wheel alignment indicator, A/V warnings for low air system pressure, and *engine low oil pressure and high water temperature. (Cylinder head temperature gauge and V-belt failure indicator for optional air-cooled Deutz engine).

MAIN BOOM - 32-110 ft. (9.8-33.7m) total length; 3 section trapezoidal† full power synchronized main boom consisting of base section and 2 power sections to 80 ft. (24.4m) and a 30 ft. (9.3m) offsettable lattice extension to 110 ft. (33.7m). Boom extension is accomplished by a 7 in. (178mm) bore, double-acting telescope cylinder with integral holding valve which extends the mid-section. Fly section is then mechanically

extended by a leaf chain attached to the mid-section which ensures positive synchronization at all boom lengths. Boom length decals are provided on boom mid-section.

BOOM NOSE - Four sheaves, 13-3/4 in. (349mm) tread diameter, mounted on roller bearings. Two floating idler sheaves, 13-3/4 in. (349mm) tread diameter, mounted on bronze bushings.

***AUXILIARY BOOM NOSE** - Removable sheave, 13-3/4 in. (349mm) tread diameter, mounted to main boom nose for single line work.

LATTICE BOOM EXTENSION - Standard 30 ft. (9.3m) lattice "swingaway" boom extension stows alongside base boom section. Boom extension swings into position; attaches and is held to main boom nose with 4 corner pins. Swingaway can be offset 0°, 15° and 30° from main boom nose.

***TELESCOPIC LATTICE BOOM EXTENSION** - 30-54 ft. (9.3-16.4m) telescopic offsettable lattice extension in lieu of standard 30 ft. (9.3m) extension stows alongside base boom section. Can be offset 0°, 15° and 30° from main boom nose.

BOOM ELEVATION - Dual double-acting 8.25 in. (210mm) bore cylinders with integral holding valves provide elevation from -2-1/2° to 75°. Pendulum angle indicator provided on left side of boom. *(Electronic, in-cab boom angle indicator optional.)

SWING - Planetary drive, 360° continuous rotation. Equipped with Grove "glide swing" with foot-activated multiple disc swing brake for precision stopping. Hydraulic swing parking brake and two posi-

SUPERSTRUCTURE SPECIFICATIONS (continued)

tion hand operated house lock controlled from operator's cab. Swing bearing is bolted to superstructure and carrier.

COUNTERWEIGHT - Removable, bolted to turntable mast, stationary.

(Weight varies according to machine specifications).

MISCELLANEOUS STANDARD EQUIPMENT - 2-3/4 lb. (1.3 kg) dry type fire extinguisher, console and domelight, circulating air fan, hydraulic test panel, electric horn.

***MISCELLANEOUS OPTIONAL EQUIPMENT** - Cab spotlight, 360° beacon light, seat belt, tachometer, outrigger level indicator.

†Patented Grove feature or patent pending.
*Denotes optional equipment.

HOIST SPECIFICATIONS

DESCRIPTION: Power up and down, equal speed, planetary reduction with integral automatic brake. *Electronic drum rotation indicator optional.

HOIST DATA	MAIN HOIST GROVE MODEL HO15H-16B		*AUX. HOIST GROVE MODEL HO15S-11B	*AUXILIARY HOIST (CONTROLLED FREE FALL) GEARMATIC MODEL 25
DRUM DIMENSIONS	12 in. dia. (305mm) 16 in. length (406mm) 17.5 in. flange dia. (445mm)		12 in. dia. (305mm) 11 in. length (279mm) 17.5 in. flange dia. (445mm)	9 in. dia. (229mm) 13 in. length (330mm) 17.5 in. flange dia. (445mm)
PERFORMANCE:	1/2 in. (13mm) dia. rope		5/8 in. (16mm) dia. rope	
MAX. SINGLE LINE SPEED:				
BARE DRUM	287 FPM (87 m/min)	287 FPM (87 m/min)	154 FPM (47 m/min)	137 FPM (42 m/min)
MEAN DRUM	340 FPM (104 m/min)	327 FPM (100 m/min)	183 FPM (56 m/min)	180 FPM (55 m/min)
FULL DRUM	383 FPM (117 m/min)	379 FPM (116 m/min)	206 FPM (63 m/min)	238 FPM (73 m/min)
MAX. SINGLE LINE PULL				
BARE DRUM	8,800 lbs. (3992 kg)	8,710 lbs. (3951 kg)	8,800 lbs. (3992 kg)	9,070 lbs. (4114 kg)
MEAN DRUM	7,730 lbs. (3506 kg)	7,435 lbs. (3373 kg)	7,730 lbs. (3506 kg)	6,880 lbs. (2097 kg)
FULL DRUM	6,890 lbs. (3125 kg)	6,930 lbs. (3143 kg)	6,890 lbs. (3125 kg)	5,205 lbs. (1586 kg)
DRUM ROPE CAPACITY	720 ft. of 1/2 in. dia. rope (220m of 13mm)		480 ft. of 5/8 in. dia. rope (146m of 16mm)	
+MAX. STORAGE			485 ft. of 1/2 in. dia. rope (148m of 13mm)	
++MAX. USABLE	585 ft. of 1/2 in. dia. rope (178m of 13mm)		395 ft. of 1/2 in. dia. rope (120m of 13mm)	
PERMISSIBLE SINGLE LINE ROPE PULL W/ 3.5:1 SAFETY FACTOR	1/2 in. (13mm) 6x37 class 7600 lbs. (3447 kg)		5/8 in. (16mm) 6x37 class 7926 lbs. (3595 kg)	
			1/2 in. (13mm) 6x37 class 7600 lbs. (3447 kg)	
			1/2 in. (13mm) 19x7 class 6170 lbs. (2799 kg)	
			1/2 in. (13mm) 19x7 class 6170 lbs. (2799 kg)	

NOTES: *Denotes Optional Equipment.

+6th layer of rope not recommended for hoisting operations (5th layer for model HO15H-16B hoist with 5/8 in. (16mm) rope. 9th layer for Gearmatic Model 25 hoist).
++With wire rope minimum 1/2 in. (13mm) below top of drum flange (5 layers of rope on drum; 4 layers for Model HO15H-16B with 5/8 in. (13mm) dia. rope; 8th layer for Gearmatic Model 25).

19x7 is a non-spin rope intended for single line operation and is not recommended for multiple part reeving.

RT525B

CHASSIS SPECIFICATIONS

FRAME - All welded box-type construction reinforced at critical points to ensure a rigid turntable mounting. Front and rear combination lifting, towing and tie-down lugs are integral with main frame.

OUTRIGGERS - Front and rear hydraulic double-box type integral with the main frame. *Optional are the exclusive Grove *spin-locks which permit the outrigger vertical jacks to be positively locked in any position throughout their stroke.

TRANSMISSION AND TORQUE CONVERTER - Remote mounted powershift with rear axle disconnect for (4x2) high range drive. Converter is engine mounted with PTO drive for hydraulic pumps. Transmission has 6 forward and 6 reverse speed ranges; 3 speeds high range (4x2 drive), 3 speeds low range (4x4 drive).

AXLES/SUSPENSION - Front: Planetary drive/steer type mounted rigid to frame.

Rear: Planetary drive/steer type pivot mounted to allow 0-12 in. (0-305mm) oscillation. *Non-drive (4x2) rear axle available.

OSCILLATION LOCKOUTS - Automatic full hydraulic on rear axle permits oscillation only with boom centered over-the-front. Automatic rear axle lockout assures a rigid platform when lifting on-rubber over side.

SERVICE BRAKES - Dual braking system, air over hydraulic actuation on all 4 wheels. Size: 17-1/4 in. x 4 in. (438mm x 102mm). Total lining area 276 sq. in. (1781 cm²). *Air dryer minimizes moisture accumulation in the system for optimum braking efficiency.

PARKING BRAKE - Spring applied, air released cab-controlled parking brake mounted on front axle.

STEERING - Front: Power assist hydraulic, controlled by steering wheel.

Rear: Full hydraulic, tiller bar control *(Rear wheel steer indicator optional). Independent front and rear steer control allows operator to choose mode of travel for optimum maneuverability.

TIRES - 16:00 x 25 (28PR) earth-mover type, tubeless. *20.5 x 25 (24PR) earthmover type, tubeless. *14:00 x 24 (24PR) tube-type.

WHEELS - All steel, disc type.

***TOW WINCH** - Front mounted, cab-controlled by rear steer lever via selector valve (excludes rope and hook). Single line pull: 9,070 to 13,500 lbs. (4114 to 6124 kg); single line speed: 50 to 75 FPM (15-23 m/min); max. drum rope capacity: 340 ft. (104m) of 5/8 in. (16mm) diameter.

MISCELLANEOUS STANDARD EQUIPMENT - Air cleaner service indicator, front and rear mounted lifting lugs, front storage well, hourmeter.

***MISCELLANEOUS OPTIONAL EQUIPMENT** - Electronic back-up alarm, pintle hooks, dual rearview mirrors, ether injection cold start aid (less canister).

HYDRAULIC SYSTEM

PUMPS - 3-section, gear-type - Combined capacity 112.5 GPM (426 LPM). *Optional is a pump disconnect with engine-jogging switch. Separate power steer/brake pump 18.7 GPM (71 LPM).

RESERVOIR - 88 gallon (333 liter) with cleanout access, exterior sight level gauge and breather cap. Strap mounted to frame.

FILTER - Return line replaceable cartridge 25 micron with bypass protection and filter bypass indicator.

CONTROL VALVES - Four-way double-acting with integral relief valves. Three individual valve banks permit simultaneous independent control of three crane functions. Maximum operating pressure 2500 PSI (175.8 kg/cm²).

***OIL COOLER** - Full flow, fin and tube type, oil to air.

POWER DISTRIBUTION - [Main hoist - 39.5 GPM (150 LPM) at 2250 PSI (158.1 kg/cm²). [Main hoist boost, *auxiliary hoist, lift and telescope - 46.5 GPM (176 LPM) at 2500 PSI (175.8 kg/cm²). [Rear steer, swing, *tow winch and outriggers - 26.5 GPM (100 LPM) at 2250 PSI (158.1 kg/cm²).

†Patented Grove feature or patent pending.
*Denotes optional equipment

ENGINE SPECIFICATIONS

MAKE & MODEL	DETROIT DIESEL 8.2L	*DETROIT DIESEL 4-53N	*DEUTZ F6L912
TYPE	8 cyl. OHV, diesel	4 cyl. OHV, diesel	6 cyl. OHV, diesel
COMBUSTION	4 cycle, naturally aspirated	2 cycle, with blower	4 cycle, naturally aspirated
BORE & STROKE	4.25" x 4.41" (108 x 112mm)	3.875" x 4.50" (98 x 114mm)	3.94" x 4.72" (100 x 120mm)
DISPLACEMENT	500 cu. in. (8194 cm ³)	212 cu. in. (3474 cm ³)	345 cu. in. (5656 cm ³)
HORSEPOWER (GROSS)	130 @ 2800 RPM (97 KW)	136 @ 2800 RPM (101 KW)	121 @ 2650 RPM (90 KW)
TORQUE (GROSS)	318 ft. lb. @ 1000 RPM (44 kg/m)	282 ft. lb. @ 1800 RPM (39 kg/m)	265 ft. lb. @ 1500 RPM (37 kg/m)
COOLING SYSTEM	Liquid	Liquid	Air cooled
ALTERNATOR	90 AMP, 12 volt	90 AMP, 12 volt	90 AMP, 12 volt
BATTERY	(2) 625 CCA @ 0°F	(2) 625 CCA @ 0°F	(2) 625 CCA @ 0°F
AIR COMPRESSOR	12.5 CFM (354 LPM)	12 CFM (340 LPM)	7.5 CFM (212 LPM)
AIR CLEANER	2 stage, dry type	2 stage, dry type	2 stage, dry type
ELECTRICAL/STARTING SYSTEM	12/24 volt, negative ground	12/24 volt, negative ground	12/24 volt, negative ground
FUEL TANK	(1) 60 gal. (227 liter)	(1) 60 gal. (227 liter)	(1) 60 gal. (227 liter)
MAKE AND MODEL	*CUMMINS V378	*CATERPILLAR 3208	
TYPE	6 cyl. OHV, diesel	8 cyl. OHV, diesel	
COMBUSTION	4 cycle, naturally aspirated	4 cycle, naturally aspirated	
BORE & STROKE	4.625" x 3.75" (118 x 95mm)	4.5" x 5.0" (114 x 127mm)	
DISPLACEMENT	378 cu. in. (6915 cm ³)	636 cu. in. (10424 cm ³)	
HORSEPOWER (GROSS)	140 @ 2800 RPM (104 KW)	140 @ 2800 RPM (104 KW)	
TORQUE (GROSS)	280 ft. lb. @ 1900 RPM (39 kg/m)	315 ft. lb. @ 1400 RPM (44 kg/m)	
COOLING SYSTEM	Liquid	Liquid	
ALTERNATOR	90 AMP, 12 volt	90 AMP, 12 volt	
BATTERY	(4) 625 CCA @ 0°F	(4) 625 CCA @ 0°F	
AIR COMPRESSOR	13.2 CFM (374 LPM)	12 CFM (340 LPM)	
AIR CLEANER	2 stage, dry type	2 stage, dry type	
ELECTRICAL/STARTING SYSTEM	12/24 volt, negative ground	12/24 volt, negative ground	
FUEL TANK	(1) 60 gal. (227 liter)	(1) 60 gal. (227 liter)	

CCA = Cold cranking amperage per battery

*Denotes optional equipment

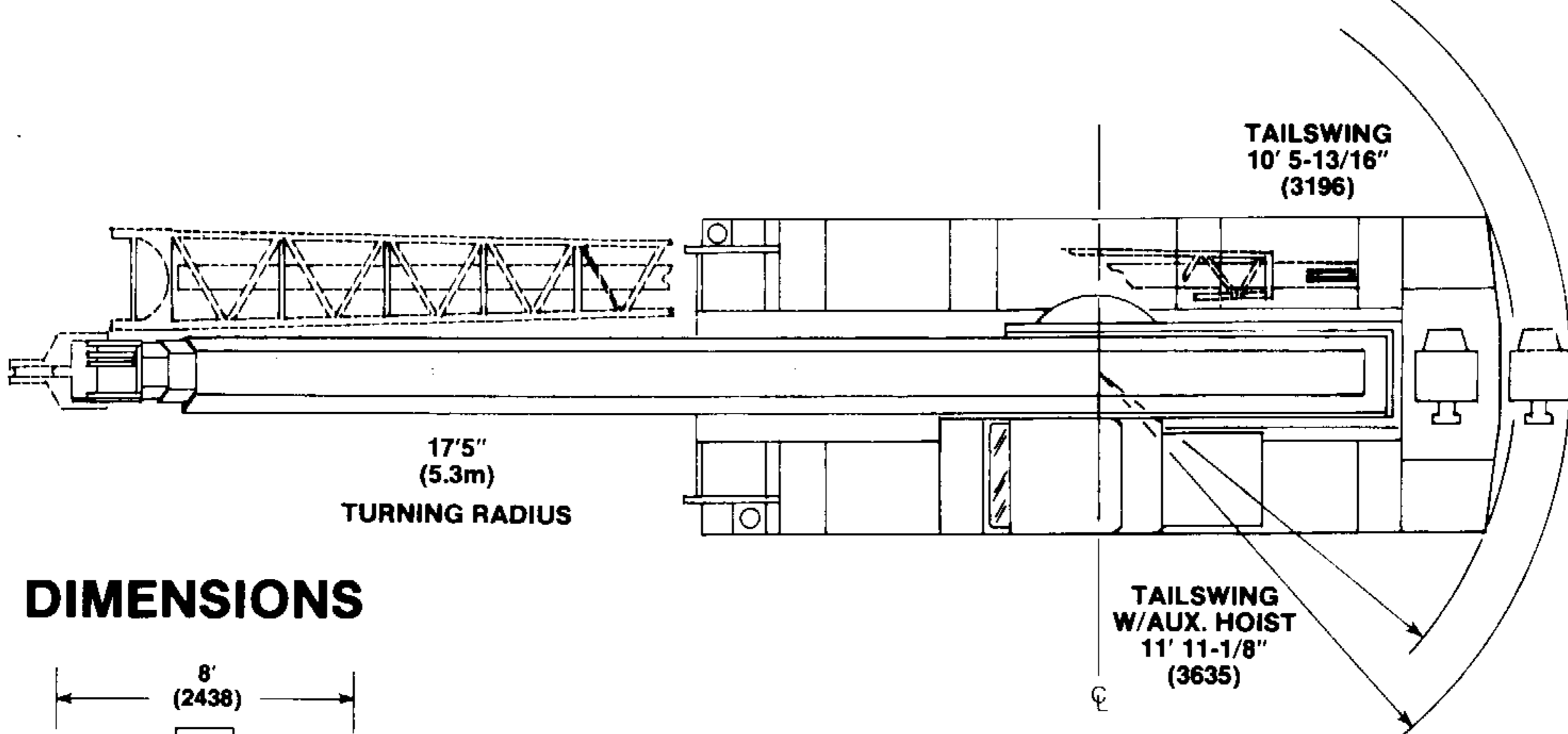

DIMENSIONS

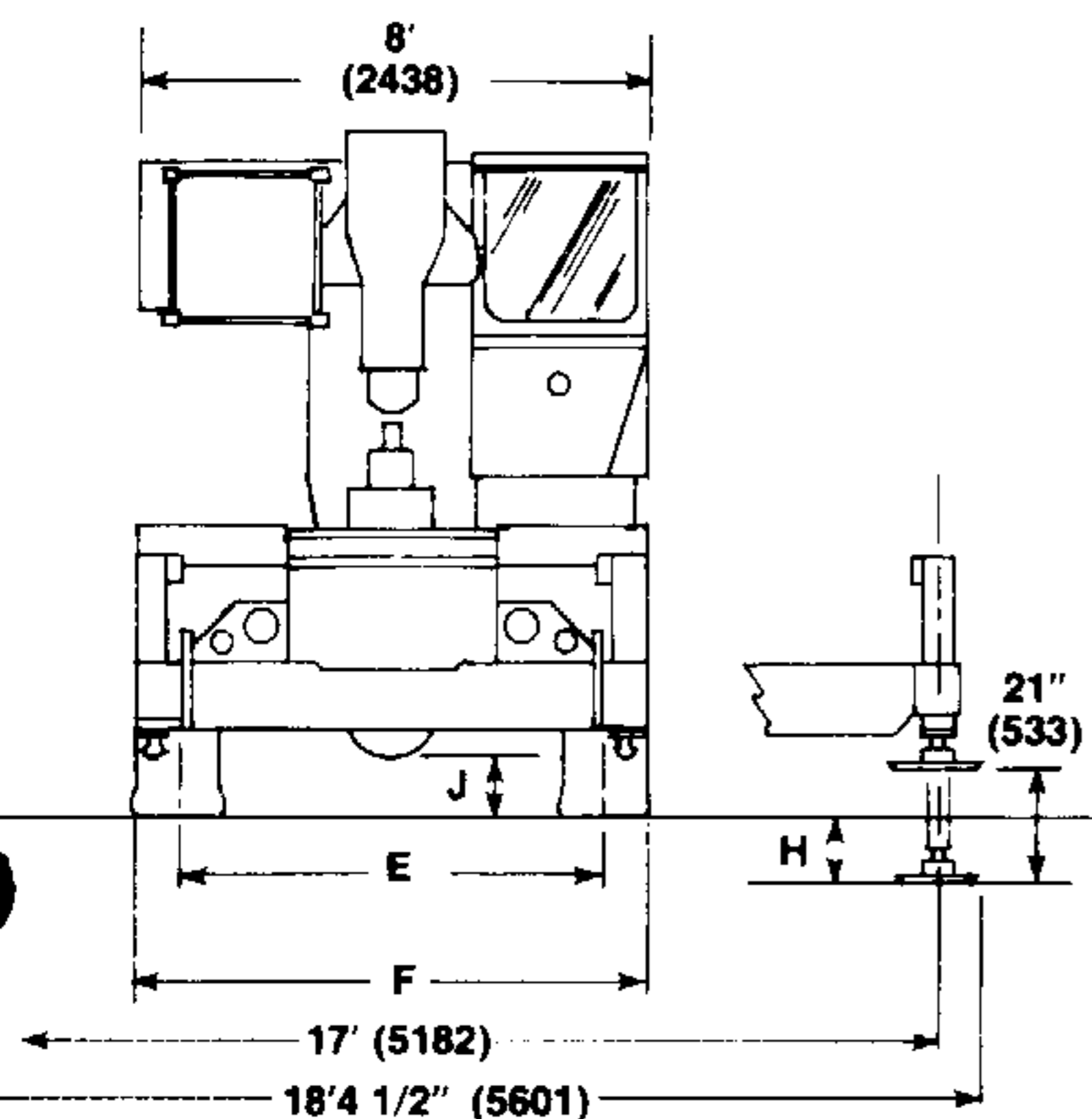

TIRE SIZE	MAIN HOIST		AUX. HOIST		D	E	F	G
	A GROVE	B GROVE	C GEARMATIC					
14.00x24	10'7 3/4" (3244)	10'11" (3327)	10'11 3/16" (3332)	2'15/16" (633)	79 1/2" (2019)	96" (2438)	10'9 5/8" (3292)	
16.00x25	10'9 3/4" (3296)	11'1" (3378)	11'1 3/16" (3383)	2'3" (686)	77 1/2" (1969)	96" (2438)	10'11 11/16" (3345)	
20.5x25	10'9 9/16" (3291)	11' 15/16" (3376)	11'1 1/16" (3379)	2'2 13/16" (681)	81 1/8" (2061)	105" (2667)	10'11 1/2" (3340)	

TIRE SIZE	H	J	K	L
14.00x24	5 5/8" (143)	1'5 1/4" (438)	22°	20°
16.00x25	3 9/16" (90)	1'7-5/16" (490)	24°	23°
20.5x25	3 3/4" (95)	1' 7-1/8" (485)	17°	16°

NOTE: Figures in () are in millimeters.

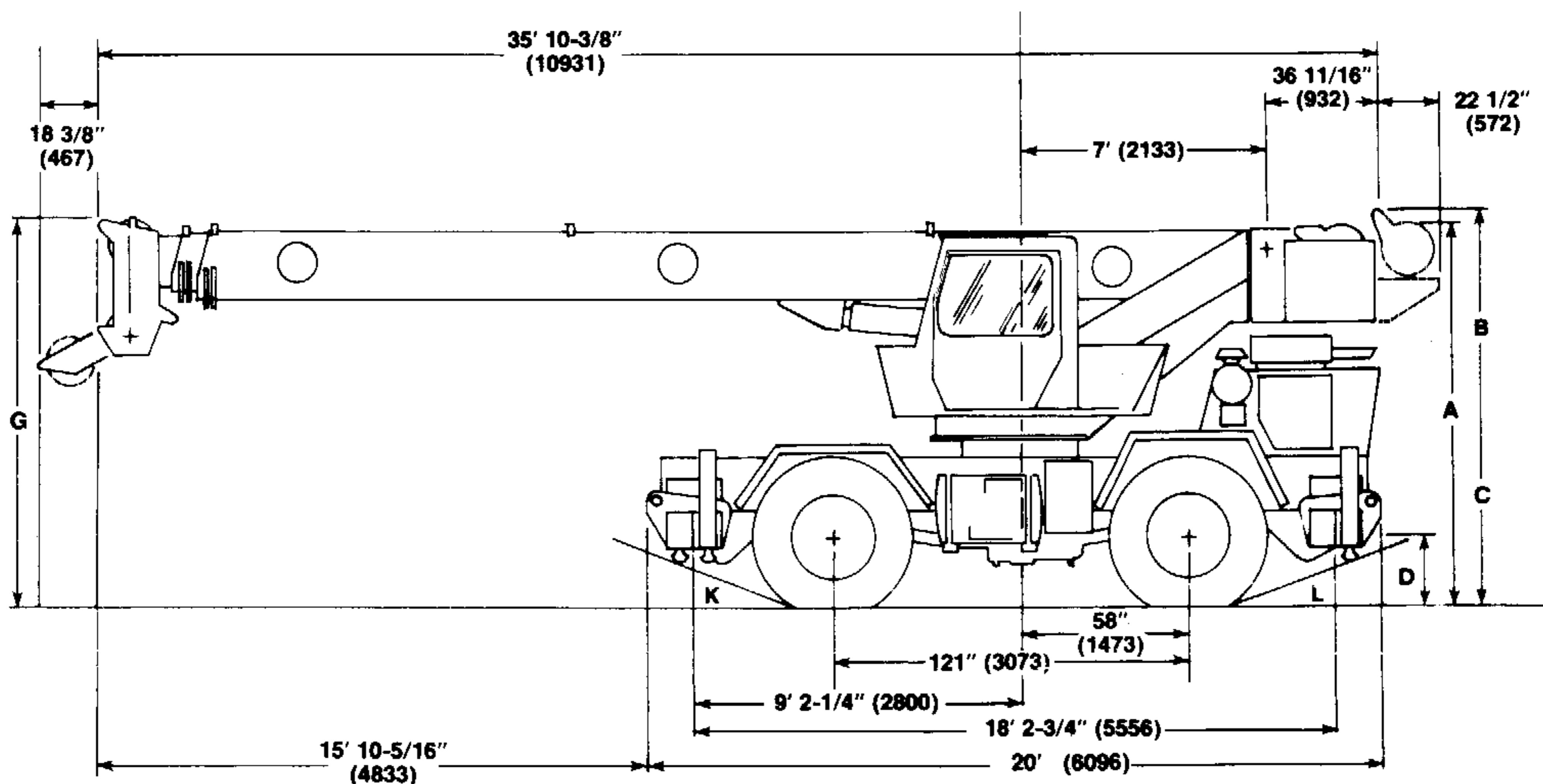

SPEED AND GRADEABILITY PERFORMANCE (WITH GM 8.2L ENGINE)

GEAR SHIFT	SPEED @ MAX. GOVERNED RPM				MAX. TRACTIVE EFFORT AND GRADEABILITY @ STALL					
	LOW RANGE (4x4)		HIGH RANGE (4x2)		LOW RANGE (4x4)			HIGH RANGE (4x2)		
	MPH	KM/HR	MPH	KM/HR	LBS	KG	% GRADE	LBS	KG	% GRADE
1st	2.4	3.9	5.8	9.3	40,428	18,338	124	16,263	7,377	36
2nd	5.1	8.2	12.0	19.3	18,633	8,452	35	7,469	3,388	14
3rd	11.2	18.0	23.2	58.7	8,031	3,643	10	3,213	1,457	3

NOTE: Performance data based on 54,300 lbs. (24,630 kg) GVW and standard SAE engine rating conditions using standard tires, transmission, engine, and axles. Performance data may vary plus or minus 10% due to variations in engine performance and vehicle weights. Machines should be operated within the limits of crank case design (30° - CAT, 20° - GM, DEUTZ, 40° - CUMMINS).

APPROXIMATE MACHINE WEIGHTS

CONFIGURATION	GVW	FRONT	REAR
w/80 ft. boom + 30 ft. Ext. (24.4m boom + 9.3m Ext.)	54,200 lbs. (24,585 kg)	26,600 lbs. (12,066 kg)	27,600 lbs. (12,519 kg)
w/80 ft. boom + 30 - 54 ft. Tele. Ext. (24.4m boom + 9.3m Ext.)	55,000 lbs. (24,948 kg)	27,700 lbs. (12,565 kg)	27,300 lbs. (12,383 kg)

NOTE: With boom lowered in travel position and with 20.5x25-24PR tires and fenders, standard engine, axles, counterweight, etc. Weights include maximum capacity hookblock suspended from boom and properly secured for travel. Weights can vary \pm 2% due to manufacturing tolerances, etc. Figures within parentheses () are metric.



GROVE MANUFACTURING COMPANY

Division of Kidde, Inc.

KIDDE

Shady Grove, Pennsylvania 17256-0021

Constant improvement and engineering progress makes it necessary that we reserve the right to make specification, equipment, and price changes without notice. Illustrations shown may include optional equipment and accessories and may not include all standard equipment.