



# RT515

15 TON CAPACITY  
25 ft. - 60 ft. BOOM

PCSA CLASS 12-79  
85% OF TIPPING

## RATED LIFTING CAPACITIES IN POUNDS

### ON OUTRIGGERS FULLY EXTENDED - 360°

Radius in Feet	Main Boom Length in Feet						
	25	30	36	42	48	54	60
12	30,000 (54.5)	30,000 (62)	30,000 (67.5)	30,000 (71)	30,000 (74)		
15	30,000 (45)	30,000 (55)	29,300 (62)	28,400 (66.5)	28,000 (70)	27,600 (73)	25,000 (75.5)
20	22,950 (23.5)	22,950 (41.5)	22,950 (52)	22,650 (59)	22,200 (63.5)	21,900 (67.5)	21,500 (70.5)
25		18,160 (23)	18,160 (41)	18,160 (50.5)	18,160 (56.5)	17,800 (61.5)	17,400 (65)
30	See Warning Note 16		13,020 (25.5)	13,020 (40.5)	13,020 (49)	13,020 (55)	13,020 (59.5)
35				10,020 (27.5)	10,020 (40)	10,020 (48)	10,020 (53.5)
40					7,910 (28.5)	7,910 (40)	7,910 (47)
45						6,560 (30)	6,560 (39.5)
50						5,510 (13.5)	5,510 (30)
55							4,590 (16.5)
Min. Boom Angle (deg.) for indicated length [No Load]							0
Max. Boom Length (ft.) at 0 deg. boom angle [No Load]							60.0

A6-829-003872 & -003404B

### 14.00x24 TIRES

Radius in Feet	Stationary Capacity	Stationary Capacity	Pick & Carry Cap. Up to 2.5 MPH
	Defined Arc (3) Over Front	360° Arc	Boom Centered (7) Over Front
10	30,000 (a)	20,510 (a)	23,330 (a)
12	23,360 (a)	15,100 (a)	22,310 (a)
15	19,610 (a)	11,470 (a)	16,430 (a)
20	13,280 (c)	6,540 (c)	12,670 (a)
25	9,500 (c)	4,310 (c)	9,500 (b)
30	7,090 (c)	3,030 (c)	6,460 (c)
35	5,540 (d)	2,170 (d)	5,330 (d)
40	4,290 (e)	1,550 (e)	4,290 (e)
45	3,360 (f)	1,260 (f)	3,360 (f)
50	2,640 (g)		2,640 (f)
55	1,990 (g)		1,990 (g)

A6-829-003983

### ON RUBBER TIRES

16.00x24

Radius in Feet	Stationary Capacity	
	Defined Arc (3) Over Front	360° Arc
10	30,000 (a)	21,950 (a)
12	26,240 (a)	16,250 (a)
15	22,110 (a)	11,600 (a)
20	13,840 (c)	6,930 (c)
25	9,650 (c)	4,510 (c)
30	7,240 (c)	3,170 (c)
35	5,720 (d)	2,280 (d)
40	4,410 (e)	1,630 (e)
45	3,440 (f)	1,080 (f)
50	2,800 (g)	
55	2,240 (g)	

### NOTES FOR RUBBER TIRES

1. Capacities do not apply to rubber tires.
2. Capacities are applicable to 14.00x24 tires.

### MAXIMUM PERMISSIBLE BOOM LENGTH:

- |              |            |
|--------------|------------|
| (a) 24.8 ft. | (e) 48 ft. |
| (b) 30 ft.   | (f) 54 ft. |
| (c) 36 ft.   | (g) 60 ft. |
| (d) 42 ft.   |            |

14:00x24  
16:00x24  
20.5x25

3. Defined Arc - Over Front
4. Capacities are applicable to 14.00x24 tires.
5. Capacities are applicable to 16.00x24 tires.
6. On rubber lifting operation, the boom should be engaged. When lifting, the boom should be reduced to the defined arc.
7. For pick and carry operation, the boom should be engaged. When lifting, the boom should be reduced to the defined arc.
8. Axle lockouts must be functioning (Reference lockout system).
9. All lifting dependent on tire inflation pressure and operation of crane.

### LIFTING CAPACITIES

#### GENERAL:

1. Rated loads as shown on lift chart pertain to this machine as originally manufactured and equipped. Modifications to the machine or use of optional equipment other than that specified can result in a reduction of capacity.
2. Construction equipment can be hazardous if improperly operated or maintained. Operation and maintenance of this machine shall be in compliance with the information in the operator's, parts, and safety manuals supplied with this machine. If these manuals are missing, order replacements from the manufacturer through the distributor.
3. The operator and other personnel associated with this machine shall fully acquaint themselves with the latest applicable American National Standards Institute (ANSI) Safety Standards for cranes.

#### SETUP:

1. The machine shall be leveled on a firm supporting surface. Depending on the nature of the supporting surface, it may be necessary to have structural supports under the outrigger floats or tires to spread the load to a larger bearing surface.
2. For outrigger operation, outriggers shall be fully extended with tires raised free of crane weight before operating the boom or lifting loads.
3. If machine is equipped with front jack cylinder, the front jack cylinder shall be set in accordance with written procedure.
4. If machine is equipped with extendable counterweight, the counterweight shall be fully extended before operation.
5. Tires shall be inflated to the recommended pressure before lifting on rubber.
6. With certain boom and hoist tackle combinations, maximum capacities may not be obtainable with standard cable lengths.

#### OPERATION:

1. Rated loads at rated radius shall not be exceeded. Do not tip the machine to determine allowable loads. For clamshell or concrete bucket operation, weight of bucket and load must not exceed 80% of rated lifting capacities.
2. Rated loads do not exceed 85% of the tipping load as determined by SAE Crane Stability Test Code J-765a.
3. Rated loads include the weight of hook block, slings and auxiliary lifting devices and their weights shall be subtracted from the listed ratings to obtain the net load to be lifted.
4. Load ratings are based on freely suspended loads. No attempt shall be made to move a load horizontally on the ground in any direction.
5. Rated loads do not account for wind on lifted load or boom. It is recommended when wind velocity is above 20 mph (32 km/h), rated loads and boom lengths shall be appropriately reduced.

### ON OUTRIGGERS FULLY EXTENDED - OVER FRONT

Radius in Feet	Main Boom Length in Feet						
	25	30	36	42	48	54	60
12	30,000 (54.5)	30,000 (62)	30,000 (67.5)	30,000 (71)	30,000 (74)		
15	30,000 (45)	30,000 (55)	29,300 (62)	28,400 (66.5)	28,000 (70)	27,600 (73)	25,000 (75.5)
20	22,950 (23.5)	22,950 (41.5)	22,950 (52)	22,650 (59)	22,200 (63.5)	21,900 (67.5)	21,500 (70.5)
25		18,350 (23)	18,350 (41)	18,350 (50.5)	18,300 (56.5)	17,800 (61.5)	17,400 (65)
30	See Warning Note 16		15,200 (25.5)	15,200 (40.5)	15,200 (49)	15,200 (55)	14,850 (59.5)
35				12,080 (27.5)	12,080 (40)	12,080 (48)	12,080 (53.5)
40					9,630 (28.5)	9,630 (40)	9,630 (47)
45						7,960 (30)	7,960 (39.5)
50						6,720 (13.5)	6,720 (30)
55							5,680 (16.5)
Min. Boom Angle (deg.) for indicated length [No Load]							0
Max. Boom Length (ft.) at 0 deg. boom angle [No Load]							60.0

NOTE: Boom Angles are in degrees.

A6-829-003869 & -003404B

# GROVE®

## FULL HYDRAULIC SELF-PROPELLED CRANE

IN POUNDS

### ON RUBBER CAPACITIES

16.00x25 TIRES

20.5x25 TIRES

Radius in Feet	Stationary Capacity		Pick & Carry Capacity Up to 2.5 MPH
	Defined Arc (3) Over Front	360° Arc	Boom Centered (7) Over Front
10	30,000 (a)	21,990 (a)	28,500 (a)
12	26,240 (a)	16,290 (a)	26,390 (a)
15	22,110 (a)	11,660 (a)	22,180 (a)
20	13,840 (c)	6,930 (c)	13,840 (a)
25	9,650 (c)	4,570 (c)	9,000 (b)
30	7,240 (c)	3,170 (c)	7,240 (c)
35	5,720 (d)	2,280 (d)	5,720 (d)
40	4,410 (e)	1,630 (e)	4,410 (e)
45	3,440 (f)	1,080 (f)	3,440 (f)
50	2,800 (g)		2,800 (f)
55	2,240 (g)		2,240 (g)

A6-829-003981

Radius in Feet	Stationary Capacity		Pick & Carry Capacity Up to 2.5 MPH
	Defined Arc (3) Over Front	360° Arc	Boom Centered (7) Over Front
10	30,000 (a)	21,520 (a)	28,300 (a)
12	26,000 (a)	15,920 (a)	25,210 (a)
15	21,900 (a)	11,520 (a)	20,180 (a)
20	13,670 (c)	7,010 (c)	13,670 (a)
25	9,950 (c)	4,620 (c)	7,860 (b)
30	7,410 (c)	3,190 (c)	6,290 (c)
35	5,670 (d)	2,240 (d)	5,060 (d)
40	4,370 (e)	1,610 (e)	4,060 (e)
45	3,440 (f)	1,120 (f)	3,290 (f)
50	2,770 (g)		2,720 (f)
55	2,150 (g)		2,150 (g)

A6-829-003979

### NOTES FOR RUBBER CAPACITIES

- Capacities do not exceed 85% of tipping loads as determined by test in accordance with SAE J-765.
- Capacities are applicable to machines equipped with:

14:00x24 (20 ply)  
16.00x25 (20 ply)  
20.5x25 (20 ply)

Cold Inflation  
115 PSI  
95 PSI  
80 PSI

2.5 MPH  
110 PSI  
80 PSI  
65 PSI

- Defined Arc - Over front includes  $\pm 6^\circ$  on either side of longitudinal centerline of machine.
- Capacities appearing above bold line are based on structural strength and tipping should not be relied upon as a capacity limitation.
- Capacities are applicable only with machine on a firm level surface.
- On rubber lifting with jib not permitted.
- For pick and carry operation, boom must be centered over front of machine and mechanical swing lock engaged. When handling loads in the structural range with capacities close to maximum ratings, travel should be reduced to creep speed.
- Axle lockouts must be functioning before lifting on rubber. (Check automatic lockout system for proper functioning: Refer to "Operation and Maintenance Manual" for description of a proper functioning axle lockout system).
- All lifting depends on proper tire inflation, capacity and condition. Capacities must be reduced for lower tire inflation pressures. See lifting capacity chart for tire used. Damaged tires are hazardous to safe operation of crane.

A6-829-003743

### LIFTING CAPACITY NOTES

Machine as originally manufactured with optional equipment other than as shown. Machine must be properly operated or maintained. Capacities must be in compliance with the standards supplied with this machine. User must consult the manufacturer through the distributor for more information. This machine shall fully acquaint user with the American Standards Institute (ANSI) standards. Depending on the nature of the structural supports under the machine and the bearing surface. Machine must be equipped with tires raised free of the ground. Front jack cylinder shall be set in the retracted position. At lift height, the counterweight shall be in the retracted position. Before lifting on rubber, maximum capacities may not be exceeded.

Do not tip the machine to the side during bucket operation, weight of loads and boom length shall be as determined by SAE Crane Capacity Chart. Do not use auxiliary lifting devices and do not attempt to obtain the net load to be lifted. No attempt shall be made to move the machine or boom. It is recommended that loads and boom lengths shall

- Rated loads are for lift crane service only.
- Do not operate at a radius or boom length where capacities are not listed. At these positions, the machine may overturn without any load on the hook.
- The maximum load which can be telescoped is not definable because of variations in loadings and crane maintenance, but it is safe to attempt retraction and extension within the limits of the capacity chart.
- When either boom length or radius or both are between values listed, the smallest load shown at either the next larger radius or boom length shall be used.
- For safe operation, the user shall make due allowances for his particular job conditions, such as: soft or uneven ground, out of level conditions, high winds, side loads, pendulum action, jerking or sudden stopping of loads, hazardous conditions, experience of personnel, two machine lifts, traveling with loads, electric wires, etc. Side pull on boom or jib is extremely dangerous.
- Power telescoping boom sections must be extended equally at all times.
- Handling of personnel from the boom is not authorized except with equipment furnished and installed by Grove Manufacturing Company.
- Keep load handling devices a minimum of 12 inches (30 cm) below boom head when lowering or extending boom.
- Loaded boom angles give an approximation of the operating radius at specified boom lengths. The boom angle before loading should be greater to account for deflection.
- Capacities appearing above bold line are based on structural strength and tipping should not be relied upon as a capacity limitation.
- Capacities for 25 ft. (7.5 m) boom length shall be lifted with the boom fully retracted. If boom is not fully retracted, capacities shall not exceed those shown for the 30 ft. (9.1 m) boom length.

#### DEFINITIONS:

- Operating Radius: Horizontal distance from a projection of the axis of rotation to the supporting surface before loading to the center of the vertical hoist line or tackle with load applied.
- Loaded Boom Angle (Shown in Parenthesis on Main Boom Capacity Chart): is the angle between the boom base section and the horizontal, after lifting the rated load at the rated radius.
- Working Area: Areas measured in a circular arc about the center line of rotation as shown on the working area diagram.
- Freely Suspended Load: Load hanging free with no direct external force applied except by the lift cable.
- Side Load: Horizontal force applied to the lifted load either on the ground or in the air.

# RT515

15 TON CAPACITY  
25 ft. - 60 ft. BOOM

PCSA CLASS 12-79  
85% OF TIPPING

## JIB CAPACITIES IN POUNDS

### 20 ft. "A" FRAME JIB

MAIN BOOM ANGLE	0° OFFSET		15° OFFSET		30° OFFSET	
	Radius (Ref) ft.	Cap. lbs.	Radius (Ref) ft.	Cap. lbs.	Radius (Ref) ft.	Cap. lbs.
75°	20.5	9,500	25.7	6,100	28.8	4,200
70	26.2	8,400	31.2	5,450	34.3	3,870
65	32.5	7,140	37.2	4,850	40.0	3,660
60	38.5	6,230	42.8	4,400	45.4	3,500
55	44.2	5,500	48.2	4,150	50.5	3,330
50	49.5	4,430	53.1	3,900	55.2	3,200
45	54.5	3,640	57.6	3,590	59.4	3,080
40	59.0	3,090	61.7	3,050	63.2	2,930
35	63.1	2,730	65.2	2,630	66.4	2,600
30	66.7	2,480	68.3	2,360	69.1	2,350

A6-829-004057B

### Notes for Jib Capacities

- All capacities are in pounds. 20 ft. jib may be used for double line lifting service. Capacities are based on structural strength of 20 ft. jib at a given main boom angle regardless of main boom length.
- WARNING:** Operation of machine with heavier loads than the capacities listed strictly prohibited. Machine tipping with jib occurs rapidly and without advance warning.
- Capacities listed are with fully extended outriggers only.
- WARNING:** Lifting on rubber with jib is prohibited.
- Reference radii listed are for fully extended main boom only.
- No load stability on outriggers with 20 foot jib installed.
  - Minimum boom angle for fully extended main boom = 0°.
  - Maximum boom length at 0° main boom angle = 80 ft.

### LIFTING AREA DIAGRAMS

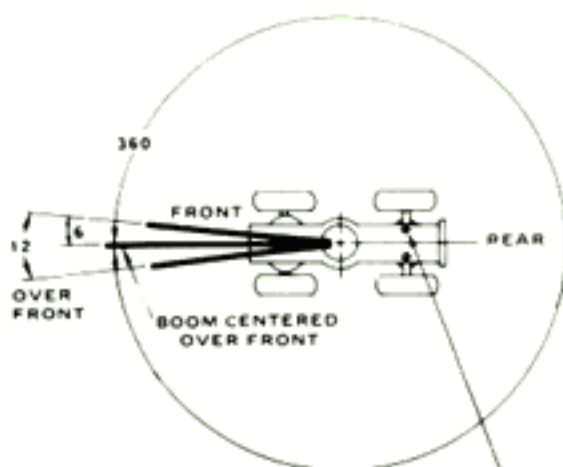

REAR AXLE OSCILLATION LOCKOUTS MUST BE SET TO MAINTAIN 360 CAPACITIES.

NOTE: BOLD LINES DETERMINE THE LIMITING POSITION OF ANY LOAD FOR OPERATION WITHIN ANY WORKING AREAS INDICATED

C6-829-003529



NOTE: BOLD LINES DETERMINE THE LIMITING POSITION OF ANY LOAD FOR OPERATION WITHIN WORKING AREAS INDICATED.

NOTE: OVER SIDE CAPACITIES CAN BE LIFTED IN THE OVER REAR AREA.

C6-829-001159

## RANGE DIAGRAM

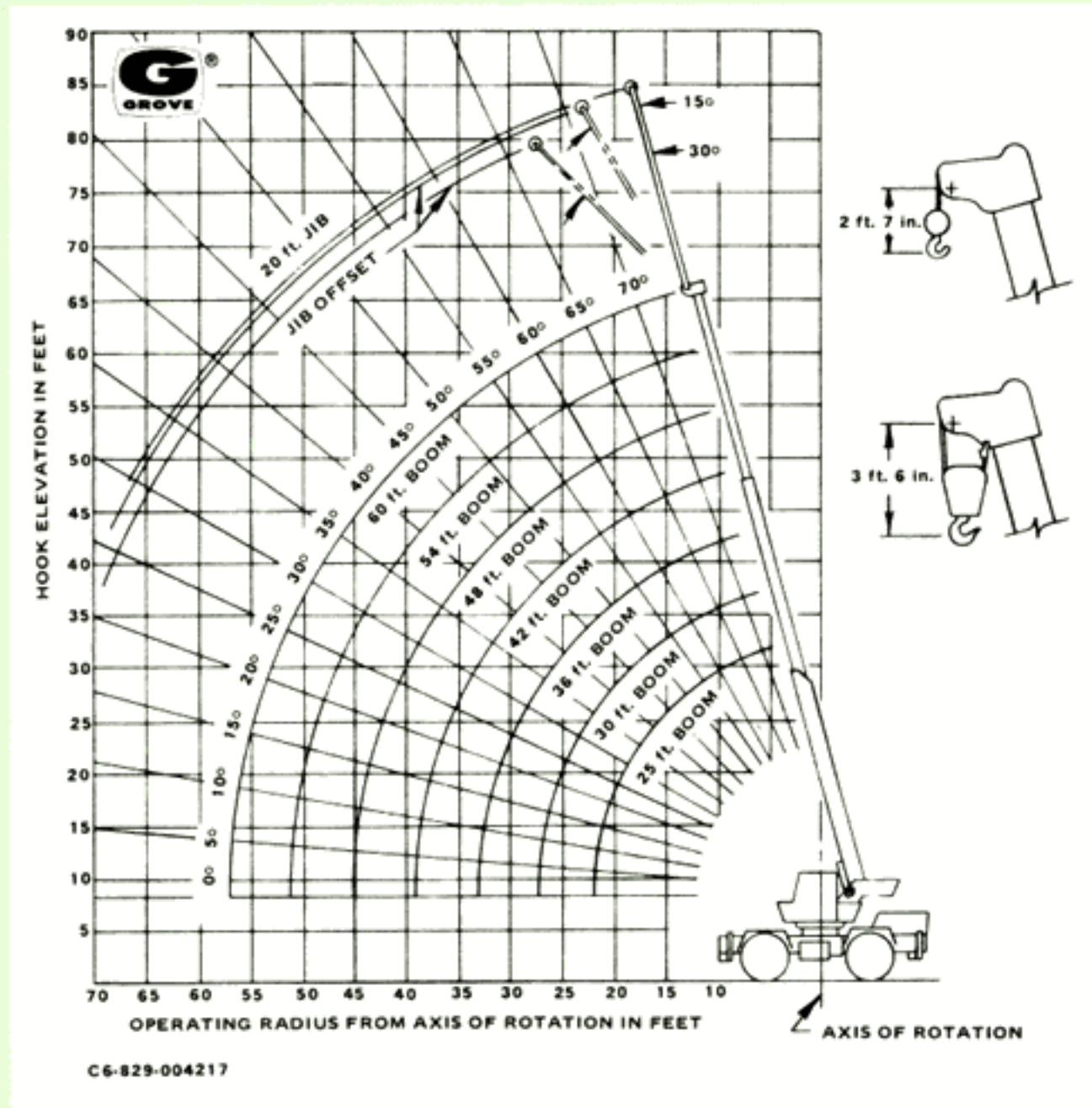

## WEIGHT REDUCTIONS FOR LOAD HANDLING DEVICES

20 Ft. A-Frame JIB	
25 ft. - 60 ft. BOOM	
STOWED . . . . .	248 lbs.
ERECTED . . . . .	1,375 lbs.

\*Reduction of main boom capacities.

HOOK BLOCKS	
22 Ton, 3 Sheave . . . . .	455 lbs.
15 Ton, 2 Sheave . . . . .	298 lbs.
12 Ton, 1 Sheave (15 7/8" OD) . . . . .	400 lbs.
12 Ton, 1 Sheave (12 1/8" OD) . . . . .	285 lbs.
Auxiliary Boom Head . . . . .	100 lbs.
5 Ton Headache Ball . . . . .	172 lbs.

NOTE: All Load Handling Devices and Boom Attachments are Considered Part of the Load and Suitable Allowances MUST BE MADE for Their Combined Weights. Weights are for Grove furnished equipment.



**GROVE MANUFACTURING COMPANY**

Division of Kidde, Inc.

**KIDDE**

Box 21, Shady Grove, Pennsylvania 17256

Phone: (717) 597-8121 Telex: 842308 Cable: GROVE MFG

**Distributed by:**