

# National

# N-80

## Articulating Crane



### From America's Truck-Mounted Hydraulic Crane Leader

- Crane Rating: 82,100 Foot-Pounds (11.4 Ton-Meters)
- Maximum Capacity: 14,400 Pounds (6.5 Metric Tons)
- Reach Above Truck Frame: 43 Feet 9 Inches (13.3 Meters)
- Reach Below Truck Frame: 30 Feet 7 Inches (9.3 Meters)
- Maximum Horizontal Reach: 38 Feet 4 Inches (11.7 Meters)

# National N-80 Articulating Crane

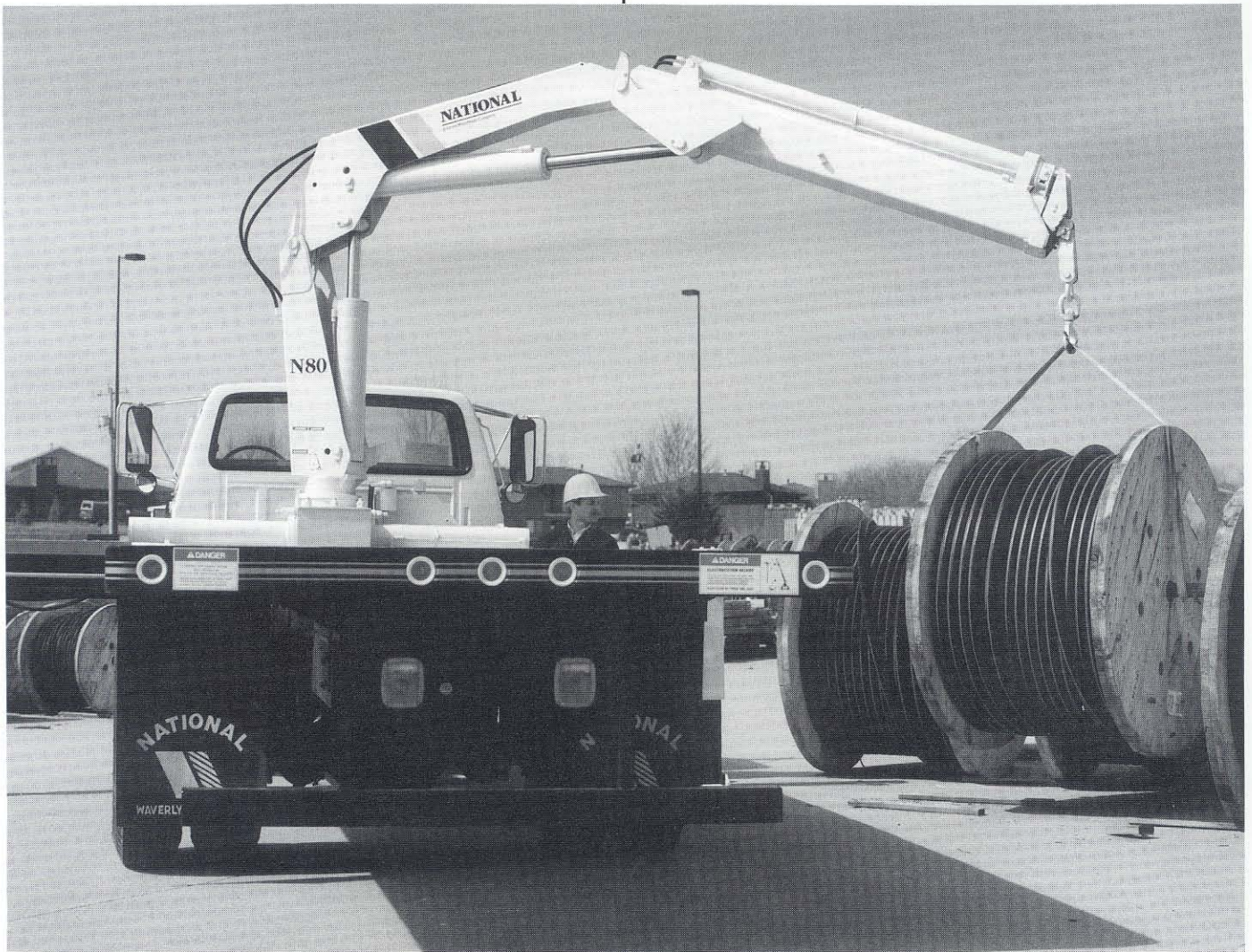

- 14,400-pound (6.5 MT) capacity
- 38'4" (11.7 m) horizontal reach
- 30'7" (9.3 m) reach below truck frame
- 20'3", 26'1" or 32'1" (6.2 m, 8 m or 9.8 m) all-hydraulic extension
- Proportional telescoping boom design
- Strong boom sections manufactured from low-alloy, high-strength steel
- Extra-large-diameter pins at pivots
- Hard chrome-plated cylinder shafts
- Clean design—hoses routed inside mast
- Extra-wide, fully-hydraulic outriggers

- Enclosed outrigger vertical cylinders
- Hydraulic overload protection is standard
- Rack-and-pinion rotation for precision and durability
- Dual waist-level controls
- Mounts on standard, single-axle trucks
- Improved three-point mounting alleviates truck frame stress
- 43'9" (13.3 m) working height personnel basket (optional)

# Why Buy the National N-80 Articulating Crane?

The N-80 exemplifies National's field-proven commitment to quality. Here are some sensible reasons to consider this compact yet rugged articulating crane for your materials and equipment handling requirements.

## Field-proven durability

- National has manufactured cranes since 1963. Over 90 percent of all Nationals ever produced are still in operation.

## More value for your investment

- Nationals consistently have the highest resale value in the industry.

## American-made

- All National parts are manufactured in America, and readily available, while service is easily obtained.

## Attention to quality

- With a National, you get more for each dollar you invest in a crane, because National never skimps on quality. Materials and components used in Nationals often cost more (because of their quality) than those found in competitive products.

## Rigid quality controls

- Each crane undergoes numerous quality inspections at each level of manufacture and assembly. No crane is shipped without a rigid final inspection.
- Component manufacturers are reviewed by National's senior management before they qualify as a supplier of parts.
- Inspections of incoming materials and components ensure that

purchased items meet National's standards.

- Material certifications are maintained and steel composition is regularly verified.
- All structural welders at National must pass AWS welder certifications.

## Industry-leading test program

- All National articulating cranes comply with ASME/ANSI (B30.22), AWS and OSHA standards.
- Each National prototype must pass the stringent test requirements of SAE J1063.
- National's test program subjects all prototypes to state-of-the-art stress coat and strain gauge testing, a procedure that measures metal deformation as small as one-millionth of an inch. These and other test procedures verify the structural integrity of National cranes.
- National Crane prototypes undergo life cycle tests, the toughest in the industry. They receive more punishment than most cranes encounter in a lifetime of on-the-job use. Every structural part of the crane is cycle-tested. Some components are operated through 60,000 cycles at full-capacity load. Testing requires thousands of working hours and takes months to complete.

## Responsive service and parts support

- Each National crane is backed by strong after-sale and service support. National's professional dealer network is worldwide. That means service

and repair resources are always nearby.

- The typical National dealer has been associated with National for well over a decade. He knows the product.
- Authorized National dealers maintain a parts-stocking program for your crane. When you need parts or service, your crane will be back on the job without undue delay or frustration.
- When a dealer cannot immediately supply a part for your crane, the factory can. National is committed to providing equipment replacement parts within 24 hours in over 90 percent of all breakdown rush orders.

## The National Service Center

- National maintains a fully equipped service center at the plant to handle factory crane mounting and special crane modifications or repairs. Most dealers can handle all but the most unusual or serious service/repair requirements.

## The National warranty

- National's warranty covers your crane against defects in materials and workmanship for one year from the date of shipment, subject to the conditions of the warranty.

## The N-80 offers these features:

- crane rating of 82,100 ft-lbs (11.4 t-m) and 14,400-pound (6.5 MT) lifting capability
- 43'9" (13.3 m) reach above truck frame

- 38'4" (11.7 m) horizontal reach
- 30'7" (9.3 m) reach below the truck frame
- Model 26M38 has two hydraulic extensions reaching to 26'1" (8 m) and two pull-out manual boom extensions to 38'4" (11.7 m)
- jib pins in place with the pin carried at the jib-tip
- booms constructed of high-strength, low-alloy steel
- hydraulic extension supplied by a two-stage cylinder
- boom nose or jib nose, equipped with swivel hook (rated for maximum crane capacity) with a safety latch, designed to accept all boom-tip options by a simple pin-on procedure
- counterbalance valves on the lift, fold and extend cylinders hold these cylinders in place until they are powered to move; they hold the cylinders in place in the event of hose failure and serve as overload relief valves to slowly lower the load in the event of an overload condition
- large-diameter, chrome-plated pins combined with composite bearings provide long life with reduced maintenance
- rack-and-pinion rotation for precision, durability and control
- wide all-hydraulic outriggers
- hose connections in hydraulic system use positive acting O-ring face seals to help eliminate leaks, minimize downtime and reduce maintenance costs

# The Basic National N-80 Articulating Crane

- all hoses routed internally where possible to protect against damage and enhance crane appearance
- control valve with low-effort, special metering spools allows precise control of all crane functions
- dual waist-level controls with identical operations of normal crane functions positioned on both sides of the machine
- mounts on standard, single-axle trucks
- three-point, clamp-on mount simplifies crane mounting, reduces crane and truck frame stress

**Caution:**  
Do not operate crane booms, jib extensions, any accessories or loads within 10 feet (3 m) of live power lines or other conductors of electricity • Jib and boom capacities shown are maximum for each section • Do not exceed capacities at reduced radii • Booms must be folded slightly to lift rated loads.

## **Built strong for reliability**

Though light in weight, the National N-80 is designed for tough materials-handling jobs. Extra-tough, high-strength, low-alloy steel gives it an exceptionally high strength-to-weight ratio.

Special counterbalance valves hold the lift, fold and extend cylinders in place in the event of hose failure, and serve as overload relief valves to slowly lower the load in the event of an overload condition.

Cylinder shafts are hard chrome-plated. High-pressure tubing is used wherever possible to reduce hose wear.

Where possible, the heavy-duty wire-braided hydraulic hoses are routed inside structural members for protection from bumps, twists, cuts and abrasions. National's special three-point mounting system absorbs loading flex, protecting the truck frame from excessive stress.

## **Heavy-duty hydraulics**

All N-80 couplings and fittings are of high quality. All hydraulic hoses, tubes and fittings have a 4:1 minimum safety factor on burst. All cylinders are double acting for smooth, positive control.

High-capacity, heavy-duty pumps are standard. An efficient, high-pressure vane pump produces full system pressure even at truck engine idle speed and maintains high efficiency throughout

its life. A two-bolt mounting flange can be integrally mounted to most PTOs to simplify mounting.

A specially-designed oil tank, with an oil level sight gauge, breather, magnetic plug and 10-micron external return line filter integrally mounted to the crane frame, reduces mounting time and space requirements. The oil tank is detachable for fast, easy maintenance.

## **Wide outriggers provide stability**

Standard, wide-span outriggers constructed from high-strength, low-alloy steel form a lightweight, stable base that can be set up quickly from either side of the truck. N-80 outriggers extend to 14' (4.3 m) horizontally and

25.5" (65.8 cm) vertically. Both horizontal and vertical extensions are powered hydraulically.

The wide outrigger span allows for lower truck chassis weight requirements and more payload capability—up to 13,200 pounds (6 MT)—on a minimum single-axle truck. Large 8" x 14" (20.3 cm x 35.6 cm) outrigger footpads help provide solid stability in soft or uneven ground conditions.

Outrigger vertical legs lock in place up or down by pilot-operated check valves. The vertical cylinders lock automatically when stowed, so they will not leak down in transit. The legs are removable for shipment and storage.

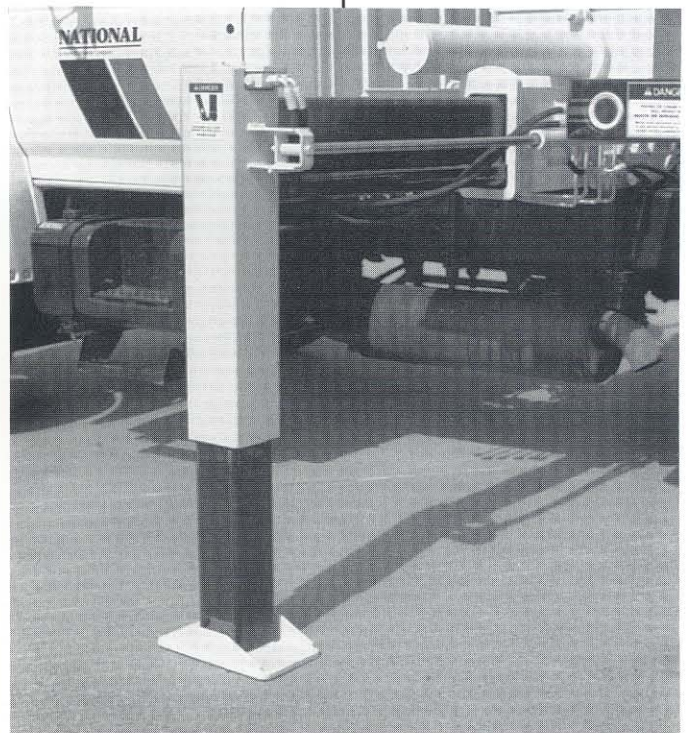

# National N-80 Reach/Capacity Data

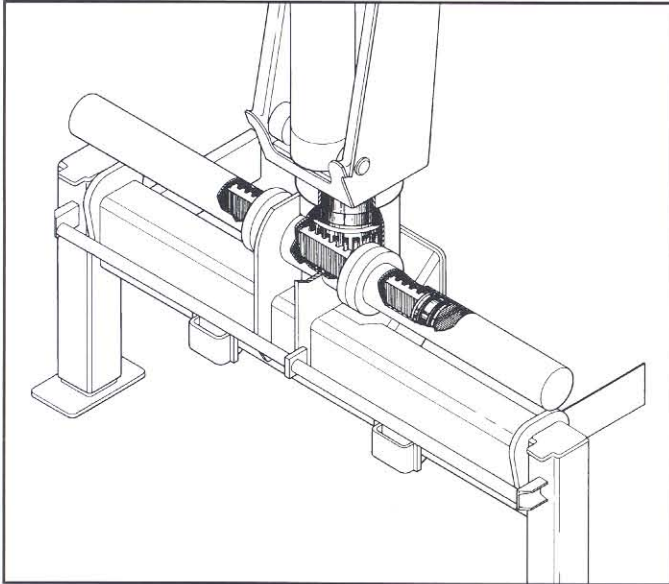

## Rack-and-pinion rotation

The N-80 gives you the smoothness, precision and control of rack-and-pinion rotation. National's rack-and-pinion system is simple, reliable and—because it has few parts—easy to maintain and service. Rack-and-pinion rotation also reduces the bulk of the crane frame above the truck, lowering the center of gravity for greater stability.

## Easy operation

The N-80 is equipped with dual waist-level controls with identical operation of normal crane functions. The operator can work the controls from either side of the crane while keeping the boom and load in full view at all times. The control knobs, illustrated with function symbols, operate the smooth, fine-metering, five-spool control valves with pinpoint accuracy. The boom can be worked and rotated simultaneously. You won't find a crane easier to operate. Additional valve banks for operating hydraulic accessories can be easily added.



## N-80 (Model 32M38) lift and reach capabilities

Lifting capacities shown at each length are maximum allowable loads, including the weight of any attached accessories.

Foot-pound rating at 14 ft. 5 in. (4.4 m): 78,500 (10.9 t-m)

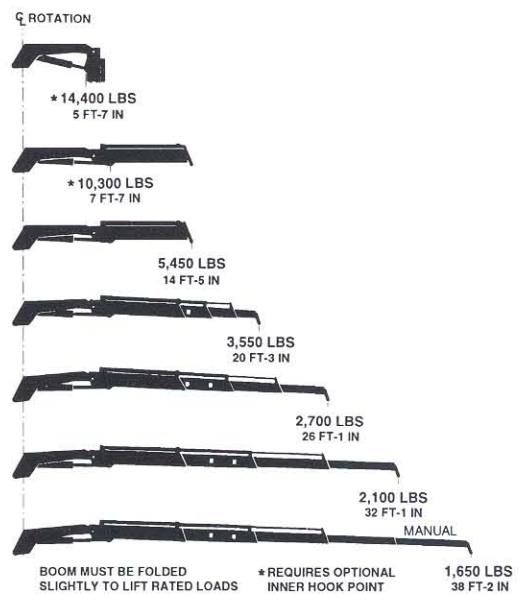

The N-80 is a "hook point" machine. Capacities shown on the capacity charts are maximum loads at specific hook points rather than at specific load radii or combinations of boom angles and boom lengths.

A load can be lifted on a National articulating crane if the load is within the capacity of the hook point and its arc about the inner boom position. If the load is within the capacity of the hook point being used to lift the load, it can be positioned anywhere the

hook arc permits by at least one crane function. All crane functions may not be able to move the load to all positions within the arc unless the position of the boom is at its best mechanical advantage. **Note: Always refer to the capacity chart (located near the operator's station) to determine what hook point will be used to lift the load. Never exceed the capacity of the hook point.**

# National N-80 Articulating Crane

## Model 20 (basic unit)

- hydraulic reservoir
- two hydraulic outriggers with hydraulic extension to 14' (4.3 m)
- frame, inner boom, outer boom with one hydraulic extension to 20'2" (6.1 m)
- 390-degree positive rack-and-pinion rotation
- five spool control valves
- identical dual controls
- boom cylinders have counterbalance valves with internal safety relief

valves to help protect against overload and hose failure

- manual truck throttle
- crane hook
- clamp-on mounting
- hydraulic vane-type pump

## Model 26

Like the basic unit (Model 20), but adds a second hydraulic extension. The hydraulic booms extend and retract under full load to 26' (7.9 m).

## Model 26M38

Like Model 26, but adds two optional manual extend sections which reach to 38'4" (11.7 m).

## Model 32

Like basic unit (Model 20), but with three hydraulic extensions to offer maximum reach of 31'11" (9.7 m).

## Model 32M38

Like Model 32, but adds an optional manual jib allowing extension to 38'4" (11.7 m).

## Special safety features

- boom cylinders have counterbalance valves with internal safety relief valves to help protect against overload and hose failure
- dual hydraulic controls with identical operations on each side
- double-acting cylinders
- pilot-operated outrigger check valves (standard)



## Technical Data

Working pressure .....	3,450 psi .....	238 bar
Pump capacity (vane-type pump).....	14 gallons/min. ....	53 liters/min.
Reservoir oil capacity .....	16.9 gallons.....	64 liters
Outrigger span.....	14' .....	4.3 m
Stowed height (above truck frame).....	6'11" .....	2.1 m
Model 32M38 weight (as shipped)* .....	4,750 lbs. ....	2,155 kg
Filter.....	10 micron replaceable (spin-on type) filter	
Rotation (non-continuous).....	390° .....	390°
Mounting space required.....	34" .....	86.4 cm
Mounting space required with optional winch.....	40" .....	101.6 cm
with optional reel.....	41.5" .....	105.4 cm
Boom rotation speed .....	10 degrees per second**	
Boom hydraulic extension/retraction speed.....	<i>(feet per second)</i> ..... <i>(meters per second)</i>	
Model 20 .....	0.60/0.7 fps** .....	0.18/0.22 mps**
Model 26 .....	1.2/1.4 fps** .....	0.36/0.44 mps**
Model 32 .....	0.7/0.7 fps** .....	0.22/0.22 mps**

**Note:** Contact the factory for continuous duty cycle applications.

\* Crane options will increase crane weight.

\*\* Approximate

# National N-80 Mounting Specifications

Mounting	Minimum Truck Specifications		
	180° Working Area	360° Working Area	Rear Mount
<p>It is essential that the truck used for mounting this crane meet the minimum requirements (shown below and at right) for capacity loads.</p>	<p><b>180° Working Area</b> This vehicle will permit lifting capacity loads in all areas around the rear of the vehicle in a 180° arc from outrigger to outrigger. No load should be lifted over the front of the vehicle unless extra stabilizing provisions are made, such as the addition of front stabilizers and/or extra weight in the truck bed.</p>	<p><b>360° Working Area</b> This vehicle will permit lifting capacity loads in all areas around the vehicle in a 360° arc. Caution should be employed when rotating from the rear to the front as the vehicle springs will compress and cause a change in the level of the vehicle. Always rotate loads slowly and smoothly to maximize control.</p>	<p><b>Rear Mount</b> The advantages of a rear-mount are: (1) the location of the crane allows the operator to effectively use the close-in working area to lift heavier capacity loads, and (2) it permits lifting capacity loads in a 360° arc. Caution should be employed when rotating from the rear to the front as the vehicle springs will compress and cause a change in the level of the vehicle. Always rotate loads slowly and smoothly to maximize control.</p>
Minimum wheelbase	207 in.	207 in.	196 in.
Rear of cab to rear axle	138 in.	138 in.	126 in.
Recommended axle rating (F)*	10,860 lbs. GAWR*	10,860 lbs. GAWR*	12,000 lbs. GAWR*
Recommended axle rating (R)*	19,000 lbs. GAWR	19,000 lbs. GAWR	34,000 lbs. GAWR
Working area	180°	360°	360°
Truck weight	11,100 lbs. (3)	13,100 lbs. (3)	16,500 lbs. (3)
Chassis weight front axle*	6,100 lbs. min.* 7,500 lbs. max.**	6,100 lbs. min.* 7,500 lbs. max.**	5,500 lbs. min. (3)*
Chassis weight rear axle*	5,000 lbs. min. (3)*	7,000 lbs. min. (3)*	11,000 lbs. min. (3)*
Frame: 50,000 PSI yield steel 110,000 PSI yield steel	15.9-in <sup>3</sup> Section Modulus 11.0-in <sup>3</sup> Section Modulus	15.9-in <sup>3</sup> Section Modulus 11.0-in <sup>3</sup> Section Modulus	00.0-in <sup>3</sup> Section Modulus 00.0-in <sup>3</sup> Section Modulus
Frame height	38 in. or less preferred		
Power take-off	70%-85% of engine speed. Minimum horsepower 33 at 1,500 rpm		
<p><b>Notes:</b></p> <p>(1) GAWR (Gross Axle Weight Rating) is dependent on all components of the vehicle (such as axles, tires, wheels, springs, brakes, steering and frame strength) meeting manufacturer's recommendations. <b>Always specify GAWR when purchasing trucks.</b></p> <p>(2) Minimum axle requirements may increase with use of diesel engines, longer wheelbase or service bodies. Contact the factory for further information.</p> <p>(3) Chassis weight includes the bed.</p> <p>(4) Diesel engines require variable speed governor.</p> <p>(5) Avoid electronic fuel-injected engines.</p>			
	<p>* If front or rear axle chassis weight is less than minimum, counterweight may be required to lift rated capacity loads to keep unit stable.</p> <p>** Maximum rating can be exceeded if GAWR is greater than 10,860 pounds. Crane options will reduce the maximum allowable front axle weight.</p>		

# National N-80 Options and Accessories

Every National is more than just a crane. It's part of a complete lifting system.

With the National Lifting System you can equip your N-80 to do more than lift or handle materials, you can equip your truck-mounted crane to perform the functions of a whole fleet of specialized vehicles, and at a fraction of the cost.

Because your N-80 can do so many jobs from start to finish, you save time, money and manpower on almost every job. You'll find that you can do more faster, and with less equipment. And that's money in your pocket.

Get the most from your National N-80. Make it more than just a crane by adding cost-efficient, hard-working accessories from the National Lifting System.

### Note:

*Weights of all accessories attached to the boom or loadline of the crane must be deducted from the effective lifting capacity.*

*Consult your dealer for specific accessory availability. Some accessories cannot be used in combination with other accessories and/or certain boom/jib combinations.*



### Remote Control

National offers a one-hand remote control for all crane models. Ideal for use where precise control and total load visibility are required, a remote control is a lightweight, easy-to-use way to add to your crane's versatility.

Fine metering and instant response mean operators can position loads or work platforms easily. A priority control valve, operated by a trigger on the remote control unit, regulates oil flow and provides fingertip speed control over all crane functions.

National's remote controls feature solid state circuitry and few working parts. They are designed for reliability.

Available in three models: Model MR4 controls the lift, turn, fold and extend functions. Model MR5 is the same as MR4, but accommodates an accessory. Model MR6 is the same as MR4, but adds two accessories.

#### Model MR4

#### Model MR5

(Requires one accessory valve section)

#### Model MR6

(Requires two accessory valve sections)

### Note:

Diesel engines require an electric shutoff.



### Radio Remote Control

National also offers a radio remote control for all crane models, eliminating handling and maintenance concerns that accompany cabled remotes. The coded FM signal operates to a range of approximately 400 feet (122 m) (varying with conditions).

#### Model MR4R

#### Model MR5R

#### Model MR6R

### Hydraulic Capacity Alert System

The Hydraulic Capacity Alert System (HCA) monitors lift cylinder pressure against the crane's constant pressure capacity chart. When the lift cylinder pressure reaches the maximum load moment, the system shuts down crane functions. Only load-relieving functions may then be operated.

#### Model HCA

### Intermediate Crane Hook Link

A load attachment link designed for installation on the outer boom section provides the capability of picking loads at 5'6" (1.7 m) and 7'7" (2.3 m). The winch option prevents the use of this option for lifting.

#### Model IL

### Winch

This extra-capacity, heavy-duty, planetary winch handles up to 4,400 pounds (1,996 kg) with a single part line block. Easy single pin attachment of boom-tip sheave head. Includes winch control and anti-two-block feature to prevent cable damage when winching up or extending the boom without paying out the winch cable. The winch option reduces the capacities by varying amounts and eliminates the inner hook point on the outer section boom. Requires 40" (101.6 cm) for mounting.

#### Model N8

#### Line pull

1st wrap .....4,400 lbs.  
2nd wrap.....4,400 lbs.  
3rd wrap .....4,400 lbs.

#### Speed

1st wrap .....31 ft./min.  
2nd wrap.....34 ft./min.  
3rd wrap .....37 ft./min.

#### Cable

95 ft. of 7/16" rotation resistant cable

#### Winch

7.5" diameter drum  
12" diameter flange, 6" wide drum, safety brake. OSHA required 18:1 ratio drum diameter to cable diameter.

#### Sheaves

Run on roller bearings with OSHA required 18:1 ratio sheave diameter to cable diameter.

#### Controls

Includes hydraulic control valve and hoses to winch.



### Accessory Control Valves

These additional control valves are required for the operation of hydraulic accessories. Complete with controls for both sides of your machine, hoses, quick couplers and piping to the end of the outer boom. Mounts easily on existing control panel. Available in two models: AH1 single function for rotator or auger and AH2 with two functions for grapple or clam bucket.

**Model AH1**  
**Model AH2**

### Hydraulic Reel

Provides hydraulic accessory lines at the end of the second hydraulic section. Comes complete with controls for both sides of the machine, reel, hose and quick couplers at the end of the second hydraulic section. Available in two models: RAH1 with single function for rotator and RAH2 with two functions for grapple or clam bucket. Requires 41.5" (105.4 cm) mounting space.

**Model RAH1**  
**Model RAH2**

### Caution:

**Do not operate crane, booms, any accessories or loads within 10 feet (3 m) of live power lines or other conductors of electricity • Jib and boom capacities shown are maximum for each section • Do not exceed capacities at reduced radii • Booms must be folded slightly to lift rated loads.**



### Pallet Fork

Turns your N-80 into a versatile, payload-packing fork lift. Great for delivering palletized materials right where you want them.

4,400 pounds (1,996 kg) capacity with adjustable throat and teeth. Handles most loads with ease. Available with hydraulic leveling or with a manual slide collar for leveling.

For extra versatility, specify a National hydraulic rotator.

Capacity .....4,400 lbs.  
at 20" center

Throat  
Opening .....41" to 65"  
adjustable

Tooth Length .....38.5"  
Tooth Width .....33.5" min. to  
57" max.  
(outside to  
outside)

Weight  
MKF .....350 lbs.  
HKF .....350 lbs.  
HKFR .....450 lbs.

### Model MKF

(Manual leveling, adjustable throat)

### Model HKF

(Hydraulic leveling, adjustable throat)  
Requires AH1 or RAH1

### Model HKFR

(Hydraulic leveling, adjustable throat with hydraulic rotator)  
Requires AH2 or RAH1

### Clam Bucket and Grapples

Turn your N-80 into more than a crane with National clam bucket or grapple attachments. The clam bucket can be used to load or move loose materials in 1/3 cubic yard (.25 m<sup>3</sup>) bites. The grapples, available in butt or bypassing type, will get a grasp on difficult handling jobs. Butt type handles up to 1/3 cord, bypassing will pick up 36" (91.4 cm) log or pipe. One person can install and remove bucket or grapples easily. Both come with hydraulic rotator and quick-connect fittings. Requires AH2 Accessory Control Valves.

	Clam	Butt Type	Bypassing
Capacity	.....1/3 yd. <sup>3</sup>	.....1/3 cord	.....36" log or pipe
Rotation	.....315°	.....315°	.....315°
Opening			
Max.	.....72"	.....72"	.....66"
Min.	.....30"	.....30"	.....6"
Weight	.....650 lbs.	.....650 lbs.	.....650 lbs.
Height			
Open	.....38"	.....38"	.....41"
Closed	.....58"	.....58"	.....54 1/2"
Width	.....36"	.....20"	.....Teeth Width
			Front 12"
			Back 20"
			(2, 3" wide teeth, 14" apart)

**Clam Bucket Model GPC**  
**Butt Grapple Model BTG**  
**Bypassing Grapple Model BPG**

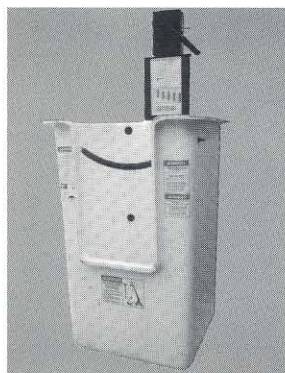

### One Person Basket

This strong, lightweight fiberglass basket with 300-pound (136 kg) capacity puts personnel where they need to be for tough maintenance and installation jobs. Gravity hung with swing lock. Available only with brake. Includes easy on-off body harness and

lanyard. Cannot be used simultaneously with winch or other boom tip options.  
Capacity .....300 lbs.  
Weight .....220 lbs.  
Dimensions .....22" x 22" x 42"  
Construction .....Fiberglass  
**Model B1-LY**

# National N-80

## Dimensional Specifications



### Hydraulic Auger

This popular accessory gives you digging depths to 4.5' (1.4 m) and flightings up to 18" (45.7 cm). It attaches easily, works fast and disconnects quickly. Requires AH1 Accessory Control Valve Group. The optional extension will provide a digging depth to 6.5' (2.0 m). Contact the factory for details.

Reach .....26' (7.9 m) or  
32' (9.8 m)  
Reduction .....4:1  
RPM.....69 rpm at 14 gpm  
(52.99 l/min)  
Pressure .....3,250 psi  
(224 bar)  
Pump.....14 gpm required  
Torque Output: 1,624 ft-lbs  
(0.2 t-m)  
Drive Weight ...205 lbs. (93 kg)  
Length.....48" (121.9 cm)  
overall  
Controls .....Requires AH1  
hydraulic control  
valve option

### Flighting and Weight

Flightings	Length	Weight
9" .....	30" double flighting	66 lbs.
12" .....	30" double flighting	78 lbs.
15" .....	30" flighting	92 lbs.
18" .....	30" flighting	123 lbs.

### Model AG

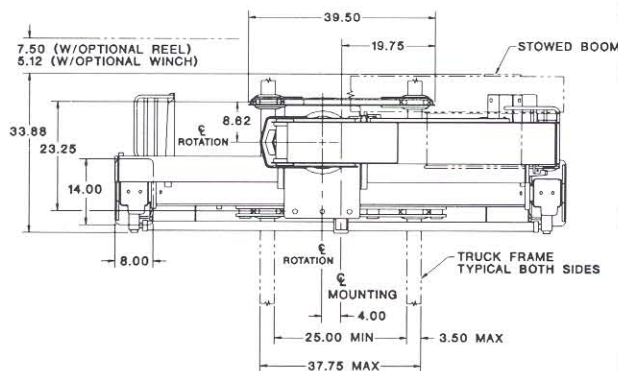
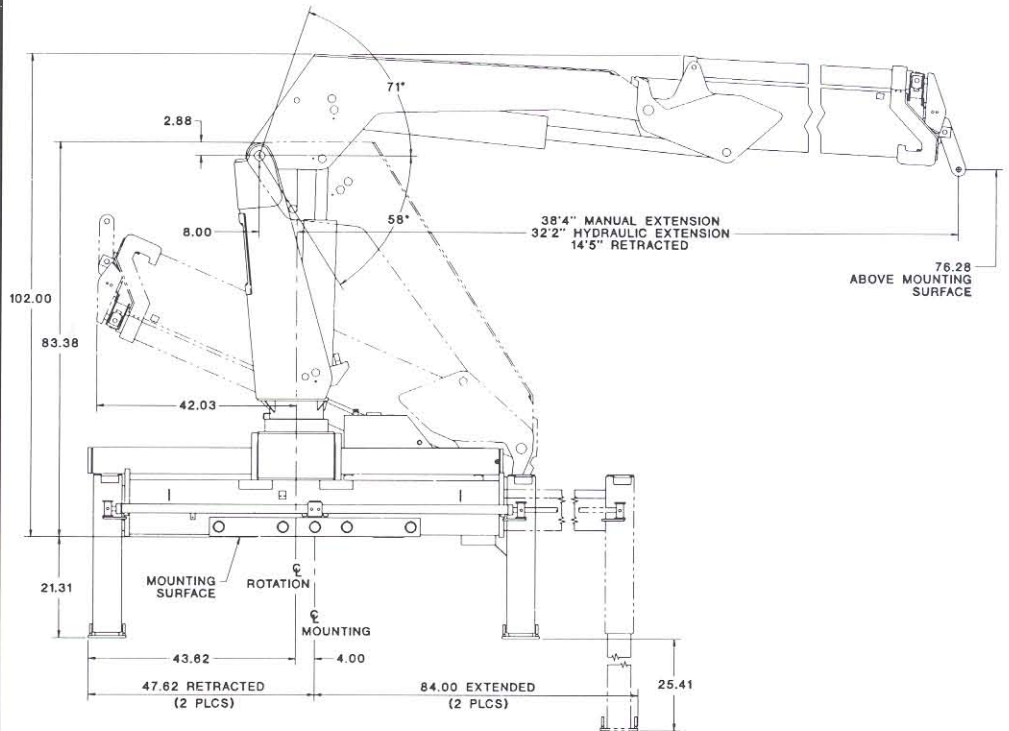

Rotation.....390° (non-continuous)  
Maximum Load Moment .....92,700 ft-lbs (12.8 t-m) at mounting surface  
Maximum Thrust Load.....19,170 lbs. (8.7 MT) at mounting surface  
Maximum Rotational Moment .....17,570 ft-lbs (2.4 t-m)

# National N-80 Proposal

Date: \_\_\_\_\_

Prepared for: \_\_\_\_\_

Submitted by: \_\_\_\_\_

(Firm Name)

(Address)

(City & State)

(Zip)

(Phone)

Signed: \_\_\_\_\_

### Description

N-80/20

N-80/26

N-80/26M32

N-80/26M38

N-80/32

N-80/32M38

### Options/Accessories

1. Optional Controls

MR4 Remote

MR4R Radio Remote

MR5 Remote

MR5R Radio Remote

MR6 Remote

MR6R Radio Remote

2. Auger

AG

3. Hydraulic Capacity Alert

HCA

4. Winch

N8

5. Intermediate Crane Hook Link

IL

6. Accessory Valves

AH1 Single Control

AH2 Dual Control

7. Hydraulic Reel

RAH1 Single Hydraulic Option

RAH2 Dual Hydraulic Option

8. Pallet Fork

MKF Manual Leveling

HKF Hydraulic Leveling

HKFR Hydraulic Leveling

with Hydraulic Rotator

9. Clam Bucket

GPC

10. Grapples

BTG Butt Type

BPG Bypassing

11. One Person Basket

B1-LY

12. Other \_\_\_\_\_

### Mounting

13. Installation:

Standard

Special

14. Stability:

180-degree

360-degree

15. Frame Reinforcing:

Weld

Bolt-Extra

16. Platform Bed:

\_\_\_\_\_ ft.

Wood  Steel

17. Weight in bed:

\_\_\_\_\_ lbs. (if required)

18. Chassis: \_\_\_\_\_

19. Rear Bumper Protection: \_\_\_\_\_

20. Back-up Alarm: \_\_\_\_\_

21. Freight: \_\_\_\_\_

This quotation will remain firm for \_\_\_\_\_ days.

Accepted by: \_\_\_\_\_

(Name)

(Title)

\$ \_\_\_\_\_  
Total Price

(Firm Name)

(Date)

# National N-80 Articulating Crane



**NATIONAL CRANE**  
A Grove Worldwide Company

General Offices: 11200 North 148th Street • Waverly, NE 68462 U.S.A.  
Phone: (402) 786-6300 • FAX: (402) 786-6363

**Your National Dealer:**

National Crane reserves the right to  
change designs, prices and specifications  
at any time without notice.