

# MODEL 36

6-7½ TON  
CAPACITY  
5.5-6.8 metric tons

## INDUSTRIAL YARD CRANE



- **LOW PROFILE** . . . only 8' (2.44m) high, the Grove Model 36 is ideal for close quarter operation, in plant or outside storage yard. Counterweight swing is only 4' (1.22m) and entirely within machine perimeter.
- **POWER-TELESCOPING BOOMS** . . . 3-boom lengths available – 20', 30' and 42' (6.1m, 9.14m and 12.8m) – providing up to 40' (12.2m) of horizontal reach and a maximum tip height of 49' (14.93m).
- **SWING** . . . 140°, 260°, or 360° continuous swing available.
- **PICK & CARRY CAPACITY** . . . 12,000 lbs. (5 443kg) over the front.
- **CARRY DECK** . . . 65 sq. ft. (6.04m<sup>2</sup>) front and side carry deck will accommodate many hard-to-handle shapes.



**HYDRAULIC  
CRANES**



MODEL 36

# SUPERSTRUCTURE SPECIFICATIONS

## STANDARD EQUIPMENT

**BOOM** - 14 ft. - 22 ft. (4.27m - 6.71m), 2-section, full power telescoping.

**BOOM HEAD** - Single sheave; root diameter 9 $\frac{1}{8}$ " (251mm); flange diameter 12" (305mm).

**BOOM ELEVATION** - Twin double-action cylinders (power up, power down) 7" diameter (178mm); integral holding valves; boom angle range: 0° to 75°; pendulum-type angle indicator.

**WINCH** - Braden Model PD10-77, power up and down, equal speed both directions; Planetary Drive with integral automatic brake; 125 ft. (38.1m) of  $\frac{1}{2}$  in. (13mm) cable; 6 x 25 EIPS, Type W construction. Drum: 9 $\frac{1}{2}$  in. (241mm) diameter, 1 $\frac{3}{4}$  in. (324mm) wide, 16 in. (406mm) flange diameter.

SINGLE LINE SPEEDS -	FULL LOAD	NO LOAD
Bare Drum	100 FPM (30.48MPM)	135 FPM (41.15MPM)
Mean Drum	120 FPM (36.58MPM)	165 FPM (50.29MPM)
Full Drum	160 FPM (48.77MPM)	220 FPM (67.06MPM)

**SINGLE LINE PULL** -  
 Bare Drum - 9,000 lbs. (4 082kg)  
 Mean Drum - 7,499 lbs. (3 402kg)  
 Full Drum - 5,625 lbs. (2 552kg)

**DRUM CAPACITY** - 490 ft. of  $\frac{1}{2}$  in. cable (149.35m of 13mm).

**BOOM SPEEDS** - Out, 16 seconds; in, 13 seconds; up, 22 seconds; down, 20 seconds.

**SWING** - 140° rotation, ball bearing swing circle, hydraulic motor powered; speed: 3 $\frac{3}{4}$  RPM. Non-free swing, automatic swing brake.

**HYDRAULIC PUMP** - 2-section; volumes calculated at 2400 RPM and 500 PSI (35.2 kg/cm<sup>2</sup>). Main section for craning functions: 44.5 GPM (168 LPM); second section for steering: 16 GPM (61 LPM). Total capacity: 60.5 GPM (229 LPM).

**CRANE CONTROLS** - Four-way double acting hydraulic valves; integral main by-pass for system relief; individual by-pass for circuit relief.

**OPERATING PRESSURE** - 2250 PSI (158 kg/cm<sup>2</sup>), crane functions; 1250 PSI (87.9 kg/cm<sup>2</sup>), steering.

**HYDRAULIC OIL RESERVOIR** - 50-gallon (189 liters) capacity with return line filter.

## SUPERSTRUCTURE - Optional equipment

**BOOMS** - 14 ft. - 30 ft. (4.27m - 9.14m), 3-section, full power; 18 ft. - 42 ft. (5.49m - 12.8m), 3-section, full power.

**JIB** - 14 ft. (4.27m) non-stowable.

**HOOK BLOCK** - 8-ton (7.2tm) single sheave with ball bearing swivel hook. 3-ton (2.7tm) overhaul ball and swivel hook.

**ROTATION** - 260° swing - similar to 140° swing with stops placed to permit 260° rotation. Standard option is 130° right and left from center over front, but requires optional outriggers. 360° continuous swing - includes hydraulic swivel to permit continuous rotation in either direction, also requires 4 outriggers.

**FLOODLIGHT, boom-mounted** - Unit swivel-mounted on base section of boom; off-on switch controlled from cab. 12V, 1000 candlepower.

# CHASSIS SPECIFICATIONS

## STANDARD EQUIPMENT

**FRAME** - High-strength steel, all-welded reinforced construction.

**CARRY-DECK** - Steel "Tread-Plate" welded to frame. Load area: 65 sq. ft. (6.04m<sup>2</sup>). Maximum loading: 125 lbs./sq. ft. (610 kg/m<sup>2</sup>). Combined hook and deck load not to exceed 12,000 lbs. (5 443kg).

ENGINE DATA	STANDARD
MAKE	Ford 300
TYPE	4-cycle gasoline
CYLINDERS	6
BORE & STROKE	4.00 x 3.98 in. (102mm x 101mm)
DISPLACEMENT	300 cu. in. (4916cm <sup>3</sup> )
NET H.P.	118 @ 2800 RPM
NET TORQUE	222 lbs. ft. @ 2800 RPM
GOVERNED RPM	2800
COOLING SYSTEM	Liquid, 26 qt. (24 liters) capacity
FUEL CAPACITY	50 gal. (189 liters) w/Protecto Cap
ELECTRICAL SYSTEM	12 volt
ALTERNATOR	30 amp
BATTERY	66 plate, 62 amp hr.

**TRANSMISSION** - Manual shift, 4 speeds forward and 4 reverse; helical gear, synchronized in top 3 speeds; spur gear provided in low. Dry type disc clutch.

**DRIVE SHAFT** - Heavy-duty industrial type with double universal joints.

**AXLES** - FRONT DRIVE AXLE, Hypoid single reduction, REAR STEER AXLE, wide-track; axle oscillation 0 to 10 in. (0 to 254mm).

**OSCILLATION LOCKOUTS** - Automatic on rear axle.

**STEERING** - Hydraulic, full power on rear wheels. Failsafe feature when power source is lost.

**BRAKES** - Service: power-assist hydraulic on front wheels. Drum and Shoe type, 156 sq. in. (1006cm<sup>2</sup>) lining. Drum diameter 16.5 in. x 5 in. (419mm x 127mm).  
 Parking: Mechanical, mounted on drive shaft. Hand lever controlled. Adjustment on hand lever.

**TIRES** - Front: (4) 10:00 x 20 - 12 ply

Rear: (2) 10:00 x 20 - 12 ply

**CHASSIS CONTROLS** - All basic controls with engine instruments, including hourmeter and electric fuel gauge.

**WEIGHT** - Basic machine: 22,510 lbs. (10 210kg)

14 ft. - 30 ft. (4.27m - 9.14m) boom add 1,100 lbs. (499kg)

18 ft. - 42 ft. (5.49m - 12.8m) boom add 2,300 lbs. (1 043kg)

Enclosed cab add 300 lbs. (136kg)

360° rotation add 100 lbs. (45kg)

Front outriggers add 1,850 lbs. (839kg)

Front and rear outriggers add 1,900 lbs. (862kg)

**WEIGHT DISTRIBUTION** - 12,400 lbs. (5 625kg) on front axle; 10,100 lbs. (4 581kg) on rear axle. (Boom and front outrigger weights affect front axle loading. If equipped with rear outriggers, rear counterweight is omitted.)

## PERFORMANCE - STANDARD ENGINE & TRANSMISSION

Axle ratio: 6.167:1 Auxiliary Gear Box: 2.41:1

Gear Range	Ratio	Speed (MPH)	Drawbar Pull (lbs.)	% Gradeability
1st	6.324:1	3.5 (5.6 KPH)	6,950 (3 152kg)	26.0
2nd	3.092:1	7.2 (11.6 KPH)	4,802 (2 178kg)	17.8
3rd	1.686:1	13.2 (21.2 KPH)	2,413 (1 094kg)	8.8
4th	1.000:1	22.2 (35.7 KPH)	1,248 (566kg)	4.4

**NOTE:** Speed and gradeability performance measured on concrete. Maximum drawbar pull and gradeability limited by torque required to slip wheels.

# DIMENSIONAL CHARTS

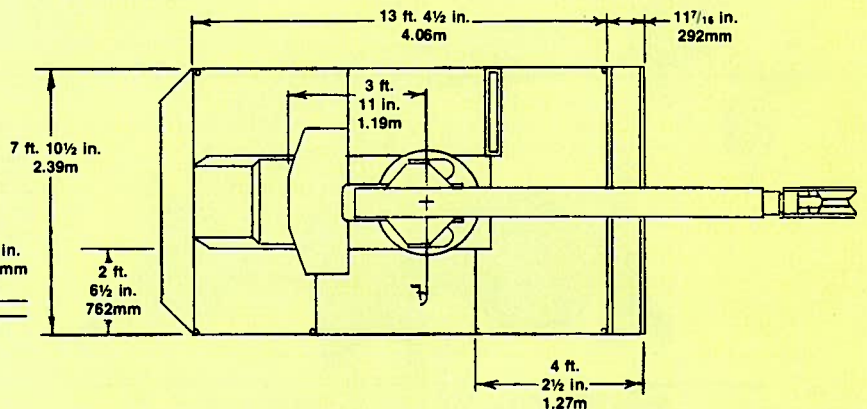
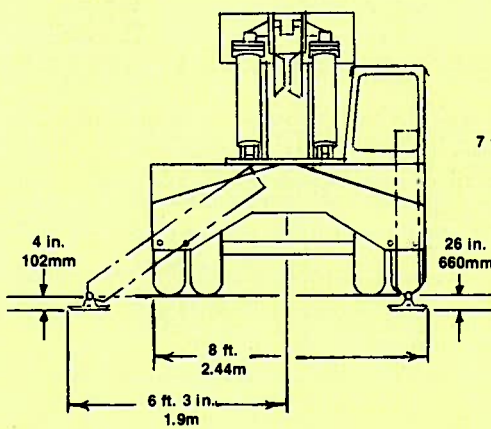
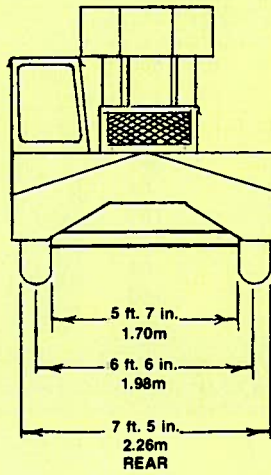
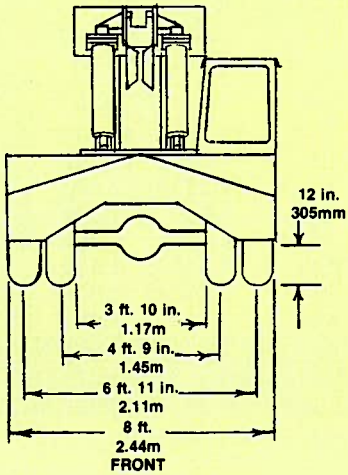
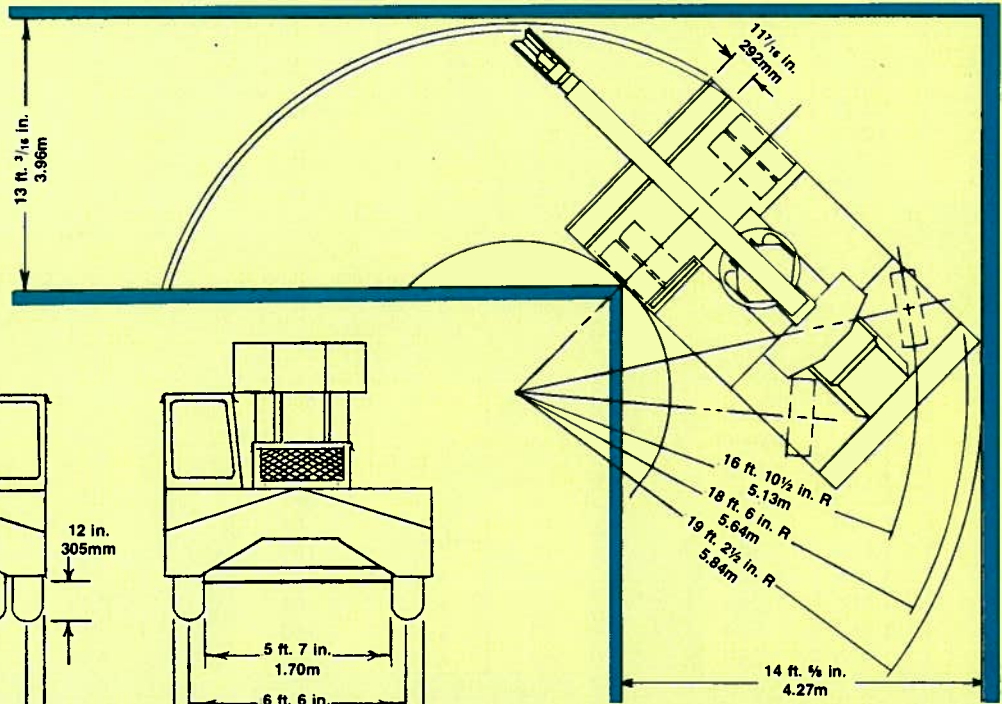
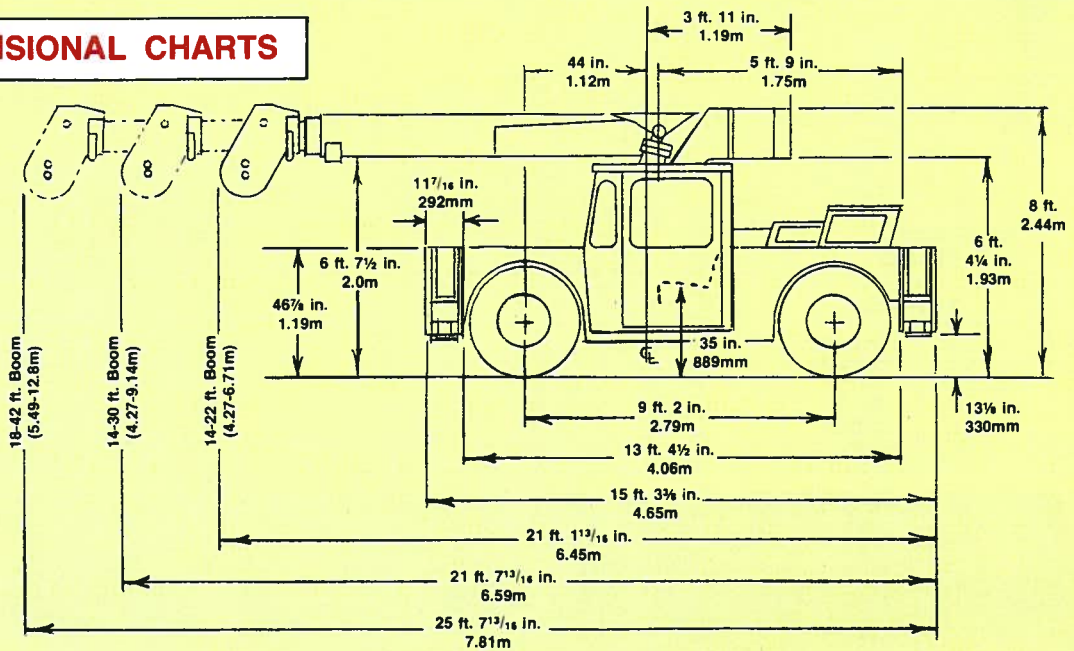



MODEL 36

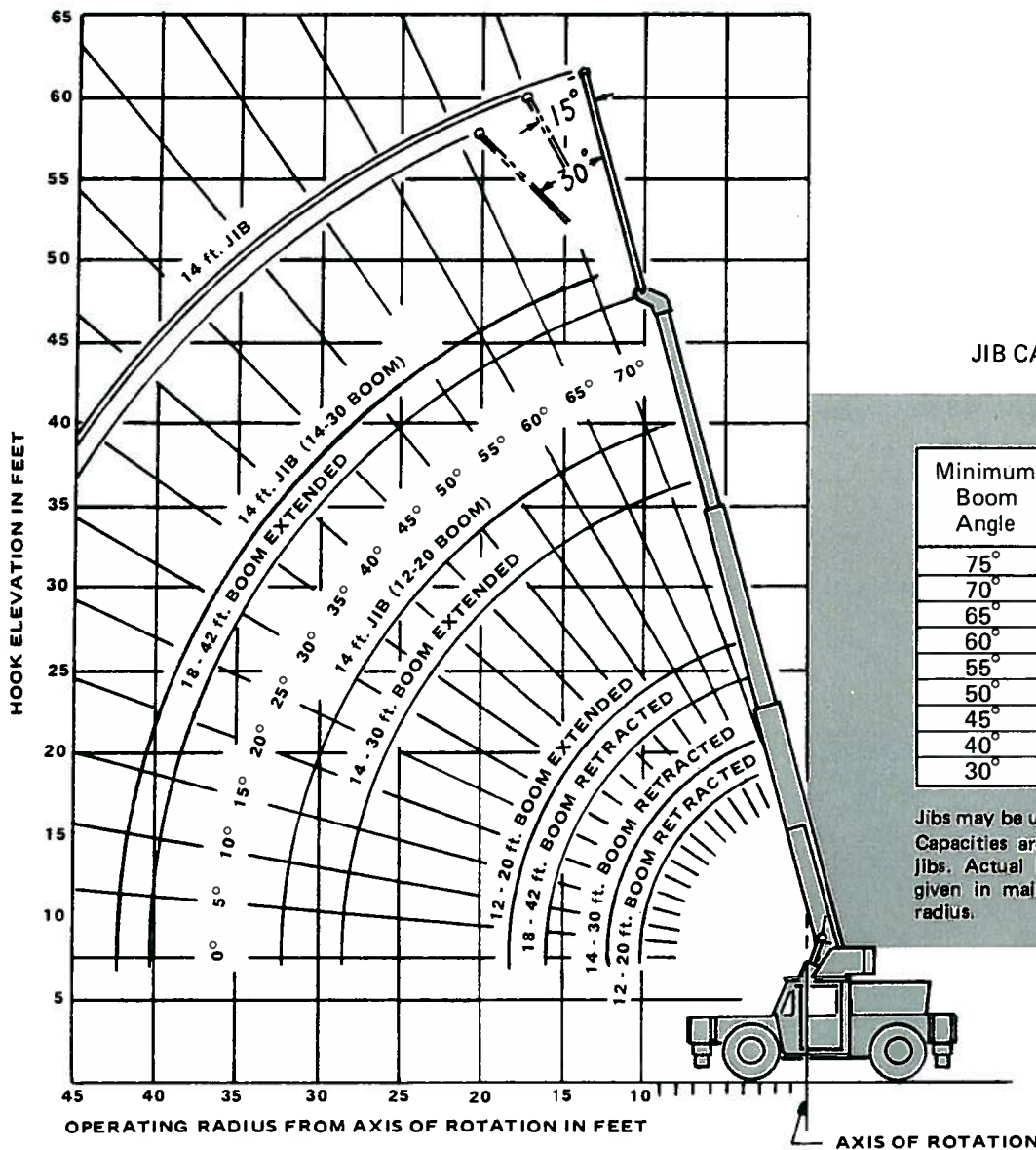

JIB CAPACITIES IN POUNDS

Minimum Boom Angle	No Offset	Maximum Offset (30°)
75°	6,200	2,600
70°	5,000	2,400
65°	4,300	2,300
60°	3,700	2,150
55°	3,300	2,100
50°	2,600	1,650
45°	2,400	1,500
40°	2,200	1,460
30°	1,900	1,200

Jibs may be used with single part line only. Capacities are based on structural strength of jibs. Actual loads must not exceed capacities given in main boom chart for same working radius.

**CHASSIS - Optional Equipment**

**ENGINE DATA**

**OPTIONAL**  
 MAKE ..... Detroit Diesel 3-53N  
 TYPE ..... 2-cycle diesel  
 CYLINDERS ..... 3  
 BORE & STROKE ..... 3.875 x 4.50 in. (98mm x 114mm)  
 DISPLACEMENT ..... 159 cu. in. (2606cm<sup>3</sup>)  
 NET H.P. .... 83 @ 2800 RPM  
 NET TORQUE ..... 156 lbs. ft. @ 2800 RPM  
 GOVERNED RPM ..... 2800  
 COOLING SYSTEM ..... Liquid, 28½ qt. (27 liters) capacity  
 FUEL CAPACITY ..... 50 gal. (189 liters) w/Protecto Cap  
 ELECTRICAL SYSTEM ..... 12 volt  
 ALTERNATOR ..... 55 amp  
 BATTERY ..... 150 plate, 204 amp hr.

**TRANSMISSION** - Power shift, forward-reverse with Torque Converter, manual speed selection; 4 speeds forward and 4 speeds reverse.

**LIMITED SLIP DIFFERENTIAL** - Same as standard except for limited slip feature.

**LP (Liquid Propane) GAS SYSTEM** - Liquid withdrawal.

**TIRES** - 9.00 x 20 - Michelin

**CAB** - Steel construction, fully-enclosed; weatherstripped, safety glass windows, windshield, skylight and left-hand door; electric windshield wiper and cab heater.

**DEFROSTER** - Electric fan.

**LIGHTS** - Group 1 - Head, tail, stop and back-up. Group 2 - Head, tail, stop, back-up, 4-way flasher and turn signal.

**PINTLE HOOK (Front)** - Flush-mounted.

**PINTLE HOOK (Rear)** - Flush-mounted.

**TOWING WINCH** - Front-mounted; 9,000 lbs. (4 082kg) capacity.

**OUTRIGGERS** - Hydraulic with integral safety holding valves. Oblique and vertical operation positions. Individually-controlled from Operator's position.

- (1) Front outriggers only - 140° swing
- (2) Front and rear outriggers - 260° swing
- (3) Front and rear outriggers - 360° swing

**CARRY-DECK POSTS** - Set of five.

**ELECTRONIC AUDIO BACK-UP ALARM**

Constant improvement and engineering progress make it necessary that we reserve the right to make specification, equipment, and price changes without notice.

## MODEL 36 RATED LIFTING CAPACITIES

### 14 ft. - 22 ft. BOOM

FRONT OUTRIGGERS  
FULLY SPREAD  
140° SWING

ON RUBBER  
140° SWING

Radius in Feet	On Rubber	
	Front	Side 70°
10	12,000	8,750
12	10,250	6,300
15	6,650	4,200
19	4,450	3,050

Radius in Feet	With Outriggers	
	Front	Side 70°
10	15,000	15,000
12	14,000	12,300
15	12,750	8,400
19	9,600	5,750

**PICK & CARRY**

**6 TON  
CAPACITY  
(5.5 metric tons)**

**WITH OUTRIGGERS**

**7½ TON  
CAPACITY  
(6.8 metric tons)**

### 14 ft. - 30 ft. BOOM

FRONT OUTRIGGERS  
FULLY SPREAD  
140° SWING

ON RUBBER  
140° SWING

Radius in Feet	On Rubber	
	Front	Side**
10	12,000	8,100
12	9,200	5,800
15	6,600	4,000
20	4,250	2,500
25	3,000	1,650
28	2,500	1,350

Radius in Feet	With Outriggers	
	Front	Side 70° *
10	15,000	15,000
12	14,000	12,000
15	12,750	8,400
20	9,000	5,400
25	6,200	3,800
28	5,100	3,200

FRONT & REAR OUTRIGGERS  
FULLY SPREAD  
260° & 360° SWING

Radius in Feet	With Outriggers	
	Front	360°*
10	15,000	15,000
12	14,000	14,000
15	12,750	12,750
20	9,000	7,000
25	6,200	4,800
28	5,100	4,000

### 18 ft. - 42 ft. BOOM

FRONT OUTRIGGERS  
FULLY SPREAD  
140° SWING

ON RUBBER  
140° SWING

Radius in Feet	On Rubber	
	Front	Side**
10	12,000 <sup>3</sup>	7,250
12	9,200	5,200
15	6,500	3,750
20	3,650	2,500
25	2,500	1,650
30	1,950	1,200
35	1,350	650
40	900	350

Radius in Feet	With Outriggers	
	Front	Side 70° *
10	15,000 <sup>1</sup>	12,000 <sup>3</sup>
12	14,000 <sup>2</sup>	8,650
15	12,000 <sup>3</sup>	5,100
20	9,000	3,700
25	6,200	2,800
30	4,450	2,100
35	3,200	1,500
40	2,300	1,000

FRONT & REAR OUTRIGGERS  
FULLY SPREAD  
260° & 360° SWING

Radius in Feet	With Outriggers	
	Front	360°*
10	15,000 <sup>1</sup>	15,000 <sup>1</sup>
12	14,000 <sup>2</sup>	14,000 <sup>2</sup>
15	12,000 <sup>3</sup>	12,000 <sup>3</sup>
20	9,000	7,000
25	6,200	4,800
30	4,450	3,500
35	3,200	2,600
40	2,300	1,900

- (1) For 15,000 lbs. lifting capacity - maximum boom length 30 ft.  
 (2) For 14,000 lbs. lifting capacity - maximum boom length 34 ft.  
 (3) For 12,000 lbs. lifting capacity - maximum boom length 38 ft.

#### NOTES TO LIFTING CAPACITIES Applies to All Above Load Charts

\*Outriggers required in spread position.  
 \*\*Capacities also applicable when outriggers are used vertically.  
 Capacities appearing above bold line are based on machinery strength and tipping should not be relied upon as a capacity limitation.

1. Rated lifting capacities, with or without outriggers, are the maximum loads covered by the manufacturer's warranty with the machine standing on a firm, level and uniform surface. Capacities do not exceed 85% of tipping.
2. For certain conditions, capacities are controlled by machinery strength. Machine tipping must not be relied upon as the capacity limitation.
3. The weights of all load-handling devices are considered part of the load lifted and suitable allowances for them should be made.



**EXCLUSIVE DUAL POSITION OUTRIGGERS** permit the oblique spread position for maximum stability or the vertical position for use where space is limited.

# THE WORLD'S MOST COMPLETE LINE OF HYDRAULIC INDUSTRIAL CRANES

**Capacities  
from  
2 through  
35 tons  
(1.8-31.8 metric tons)**



**MODEL 24**  
4/6-Ton Capacity  
3.6/5.4 metric tons



**MODEL 1012**  
15/17½-Ton Capacity  
13.6/15.9 metric tons

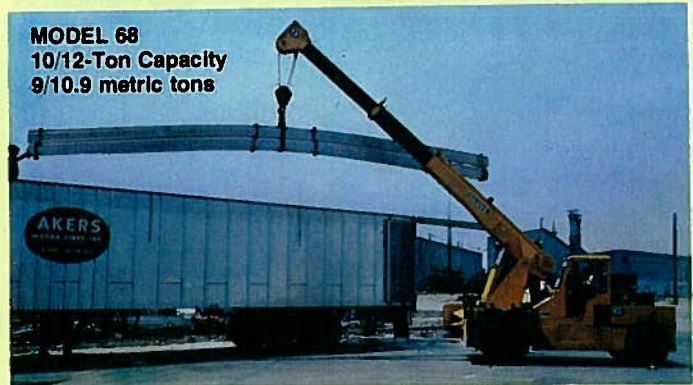

**MODEL 68**  
10/12-Ton Capacity  
9/10.9 metric tons



**STEVEDORE**  
2-Ton Capacity  
1.8 metric tons



**MODEL 2535**  
25/35-Ton Capacity  
22.7/31.7 metric tons



**INDUSTRIAL  
CRANES**

*Your Grove Distributor*

**GROVE MANUFACTURING COMPANY**  
A DIVISION OF WALTER KIDDE & COMPANY, INC.  
P. O. BOX 160/GREENCASTLE, PENNSYLVANIA 17225