

National Series 700B Proposal

Date: _____	
Prepared for: _____	

Submitted by: _____	

(Firm Name)	

(Address)	

(City & State)	

(Zip)	

(Phone)	
Signed: _____	

National reserves the right to change designs, prices, and specifications at any time without notice.	
Your National Dealer	

Description	Price
1. Series _____	\$ _____
2. Boom _____	_____
3. Jib _____	_____
4. Rear Stabilizers	_____
5. Front Stabilizers <input type="checkbox"/> Std. <input type="checkbox"/> Tilt <input type="checkbox"/> Single Front	_____
6. Line Block <input type="checkbox"/> 2 Part <input type="checkbox"/> 2 & 3 Part <input type="checkbox"/> 4 & 5 Part	_____
Accessories	_____
7. _____	_____
8. _____	_____
9. _____	_____
10. _____	_____
Mounting	_____
11. Installation: Behind Cab	_____
12. Installation: Rear Mounting (add to installation charge above)	_____
<input type="checkbox"/> Air Throttle	_____
<input type="checkbox"/> Rear Mounting Hydraulic Group	_____
<input type="checkbox"/> High-Tensile Torsion Box	_____
<input type="checkbox"/> Reverse Frame Conversion Kit	_____
<input type="checkbox"/> HO Outriggers	_____
13. Frame Reinforcement: <input type="checkbox"/> Weld <input type="checkbox"/> Bolt-Extra	_____
14. Platform Body _____ ft. <input type="checkbox"/> Wood <input type="checkbox"/> Steel	_____
15. Weight in bed _____ lbs. (if required)	_____
16. Boom rest: <input type="checkbox"/> Parallel <input type="checkbox"/> Low <input type="checkbox"/> Other	_____
17. 1,100-lb. front bumper (if required) _____	_____
18. Mount Stabilizers _____	_____
19. Chassis _____	_____
20. Rear Bumper Underride Protection <input type="checkbox"/> Ordered <input type="checkbox"/> No Ordered	_____
21. Freight _____	_____
This quotation will remain firm for _____ days.	
Accepted by: _____	\$ _____
(Name)	TOTAL PRICE
(Firm Name)	(Date)



NATIONAL CRANE
Subsidiary of Kidde, Inc.
KIDDE

General Offices: 11200 North 148th Street/Waverly, NE
68462/402/786-2240
Telex: 438061
Service Center: 701 N.W. 27th Street/Lincoln, NE 68528/402/474-2666

NATIONAL SERIES 700B

Truck-mounted Telescoping Cranes and Accessories
Maximum Vertical Reach: 120 Feet (36.6 Meters)
Maximum Capacity: 33,000 Pounds (15 Metric Tons)

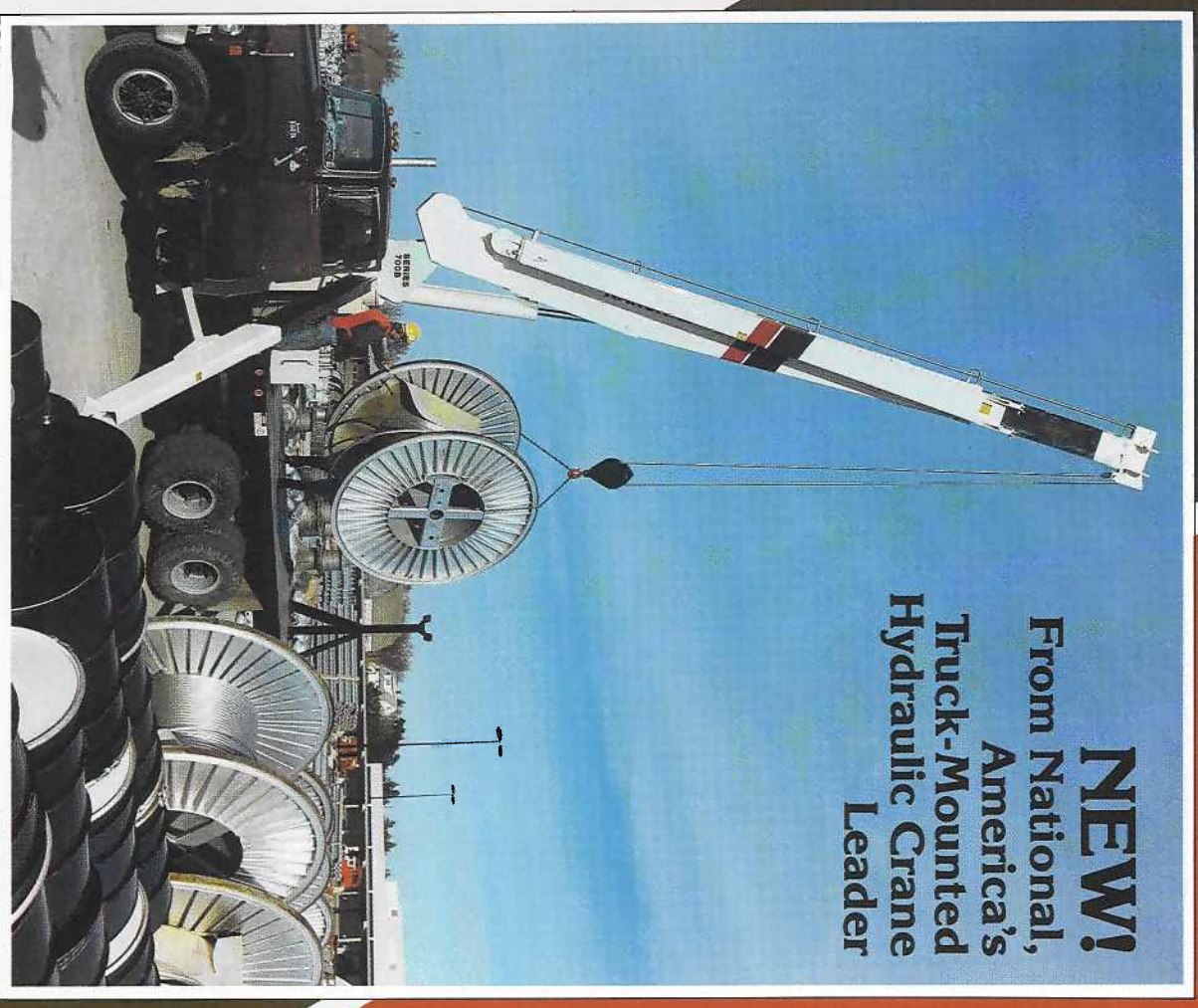

NEW!
From National,
America's
Truck-Mounted
Hydraulic Crane
Leader

NATIONAL SERIES 700B

An all NEW, high capacity, hydraulic telescoping crane from National

National is America's leading manufacturer of commercial truck-mounted telescoping and articulating cranes. We provide cranes for a wide range of jobs. Nationals are tough, durable, and dependable. And they are designed for ease of operation.

With a National, you are assured of a well-engineered, well-manufactured, and fully-tested machine designed for your applications. At National, we put quality first. Our commitment to product quality is our pledge to provide our customers with reliable products designed to provide years of service.

- Standard anti two block feature to prevent cable damage when winching up or extending the boom without paying out the winch cable
- Wide 18-foot outrigger span for stability
- Mounts on most standard, heavy-duty commercial trucks with the versatility of four mounting configurations
- Simple mounting: subbase to eliminate truck reinforcing and in some cases counterweight
- Boom pivot and hoist cylinder bearings provide longer life and lower maintenance
- Tall back rest at operator control station
- Standard tandem pump system isolates winch from other crane functions to provide independent operation capability
- Horn and stop switches at control stations
- Complete accessory line adds to versatility
- Boom access holes allow easy access to telescoping cylinder holding valves and plumbing for serviceability
- Precision machine level at both operating stations
- 60-gallon oil tank with sight gauge, breather, suction strainer, clean-out, and magnetic plug
- 33,000-pound capacity
- Long vertical reach—up to 120 foot high
- National's field-proven hydraulic four-section boom
- Higher capacities in normal operating areas
- National's industry-acclaimed box-section boom construction
- Large bolt-in wear pads in boom that last longer and are easier to replace
- Standard high-performance planetary winch with 9/16-inch diameter rotation resistant wire cable
- Dual controls in SAE recommended orientation; each with foot throttle
- Control rods supported by nylon bearings, promoting smooth operation and serviceability
- Planetary rotation gear box with a hydraulic release brake and a slip-through feature that helps protect the rotation system against damage from accidental side loading

National's anti two block system is standard on all National cranes (as of June 1, 1986). Photos in this brochure taken prior to that date may not show the crane equipped with the current standard anti two block protection system.

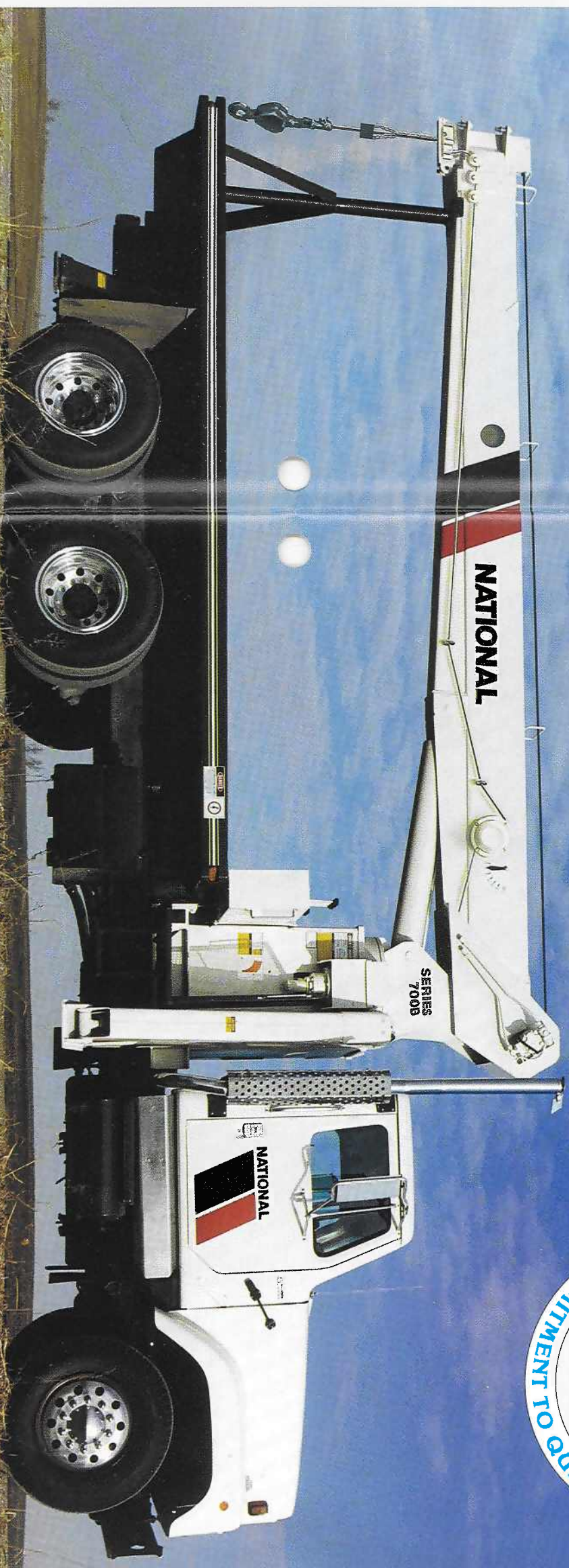

Strong Four-Plate Booms

Through computer aided design, National has removed weight from the Series 700B boom sections. We fabricate our telescoping boom sections from four high-strength steel members welded with perpendicular corners. This box-section construction lets us use thicker top and bottom plates for extra strength. The use of thinner side plates means increased capacity through lower boom weight. Only strong, low alloy steel is used in National booms. It is welded with automatic, low-hydrogen techniques for extra strong seams. Corner seams are ultrasonically tested for proper penetration.

The National Series 700B is equipped on all sides with large nylon wear pads impregnated with lubricants which provide a smooth, long-life operation. The wear resistance of the material used in the Series 700B pads is unexcelled by competitive models.

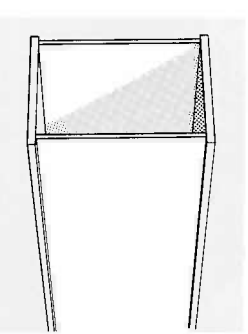

Caution
Do not operate crane booms, jib extensions, any accessories, or loads within 10 feet (3m) of live power lines. Do not exceed jib capacities at any reduced boom lengths.

Sequential Extension

National introduced sequential, full-load extension to the industry. Our boom sections interlock for sequential extension. The larger, stronger boom sections extend first for greater strength. National's patented locks are mechanical, not hydraulic. These field-proven locks provide reliability with no excessive noise or wasted hydraulic power. They are just one more example of how National know-how and attention to quality pays off in performance for you.



Dual Controls

Dual controls are standard on the Series 700B. The extra fine metering and low spool force give you smoother, more precise control. Crane controls are identical on each side with SAE recommended orientation of functions. That means you always work the same control with the same hand. Dual stations provide more efficient operations and

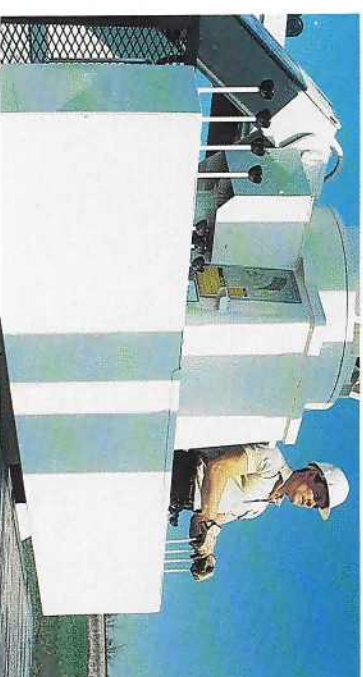

Direct Mounted Holding Valves

On the Series 700B all holding valves are mounted directly to the cylinders for added safety in the event of hose failure.

Anti Two Block

The 700B is equipped with a standard anti two block system. Two blocking occurs when the winch cable and attachments contact the underside of the boom or jib sheave case, whether by winching up or extending the boom without paying out the winch cable. When this



happens, the cable can be damaged by crimping or over-tensioning. The anti-two block attachment prevents cable damage by sensing the position of the winch cable end attachments with respect to the sheave case and shutting down the functions that can cause two blocking.

greater load visibility. Each station is equipped with kill and audible warning

switches. A system pressure gauge is standard. Foot throttles allow identical foot operation of engine speed from either side. Control rods are supported by nylon bearings, promoting smooth operation and reducing lubrication requirements.

High Performance Planetary Winch

Every 700B comes standard with a high performance planetary gear drive winch. A "Burst-of-Speed" feature for faster, more efficient pay-out and pick-up of unloaded cable is standard. The "Burst-of-Speed" winch circuitry increases line speed up to 60% over normal.

This high capacity winch features high line pull and fast, standard speed. For fine control, both brake and counter-balance valve are standard. The winch is filled with 9/16" rotation resistant wire cable to prevent spinning and twisting of the loadline. See the winch data chart on page nine for further information.

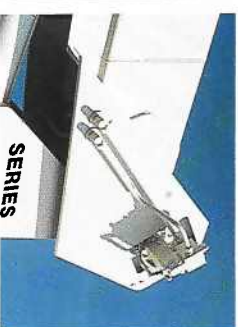

Positive Planetary Turret Rotation

The planetary rotation gearbox with a hydraulic release brake allows the gearbox to backdrive whenever excessive side load is applied to the boom, reducing shock loads on the upper and lower crane structure and gearbox. The turret drive is designed with extra heavy bearings below the drive pinion. The gearbox and rotation bearing mounting surfaces are precision machined after welding. This ensures consistent tooth alignment for smooth rotation and low wear, even under maximum loads. The entire turret glides smoothly on a low inertia ball bearing race. Rotation is 375° noncontinuous.

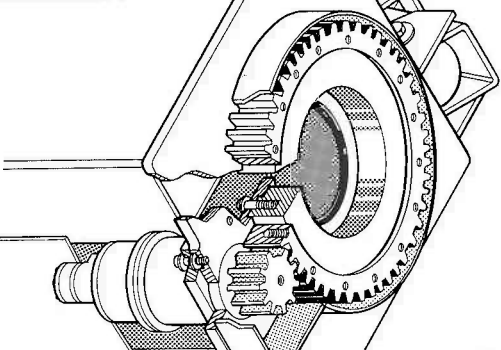

"A" Frame Stabilizers

The Series 700B is equipped with "A" frame rear stabilizers with a wide, ten-foot span for greater stability and lower counterweight requirements.



Wide Stance

We've given our Series 700B the industry-acclaimed National out-and-down outriggers for a consistently wide stance and better leveling on uneven ground. The outriggers retract smoothly, without binding under load, first moving up, then in. Their efficient design and wider span—18-foot (5.49m)—gives you solid stability. With less truck weight, you can carry larger payloads more economically. A precision-mounted level indicator aids the operator in leveling the unit during the set-up procedure.

Easy Service, Low Downtime

We designed the Series 700B for easy service and minimum downtime. Compare these features:

- Console cover for easy access to control valve
- Boom access ports for easy maintenance of cylinders and locks (note photo below)
- Rotation drive and brake located outside of frame for easy access and service
- 37° flare fittings used throughout to reduce the possibility of fluid leakage.
- Extra-capacity (60 gallons) oil reservoir to reduce heat buildup. Complete with standard clean-out, suction strainer and magnetic plug for easy maintenance, long life.



Unitized Mounting

Our unitized mount includes a one-piece, ten-inch deep subbase that extends along the frame and supports the crane and bed. It reduces counterweighting and increases stiffness and stability. Reinforcing is not required on trucks with 15.9 inch³ section modulus frames of 100,000 PSI minimum yield steel. The crane and unitized mount ship separately, then bolt together to form one solid integrated unit.

Lower Truck Requirements

We have engineered the Series 700B to lower your truck requirements. Our wider outrigger span, "A" frame rear stabilizers and unitized mount take the stress, not the truck. That means that the 700B can mount on trucks with lower axle ratings and still meet DOT and stability standards with ease. It all adds up to lower maintenance, lower costs and longer truck life for you.

National's "Out-and-Down" Stable Outriggers

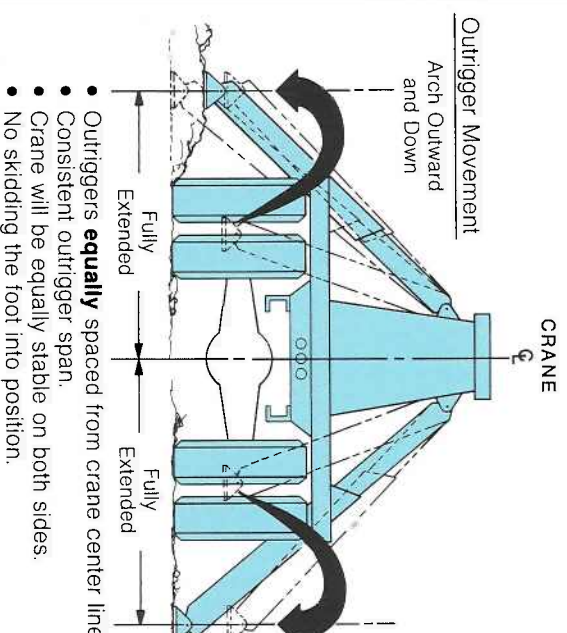

National Series 700B

National Warranty, Parts and Service

The National Testing Program

National Crane established its original product durability standards by carefully evaluating the performance of competitive machines. Taking the best performances from these tests, National engineers set their own standards **more than 50% higher!** This is the same testing program each National must pass today.

Before a new model is released for production manufacturing it is subjected to state-of-the-art testing. For example, a plastic-based "brittle lacquer" coating is applied to the boom. After loading the boom, test engineers inspect the coating for cracks. The special lacquer has virtually no elastic qualities, so stretching or deformation of the metal shows up in "fractures" of the coating, perpendicular to the direction of stretching.

This procedure indicates where engineers are to place strain gauges, tiny chips printed with electronic circuitry which expand or contract with changes in the metal. Minute changes in electrical resistance are

measured by a computerized strain gauge monitor and printed out for engineering studies. These strain gauges measure current fluctuations as small as one-millionth of an ohm—which measures metal deformation as small as one-millionth of an inch. After strain gauge testing, the prototype of each new model undergoes life-cycle testing. The crane is operated at full-load through a full life-cycle under close scrutiny. Outriggers, frames, and other components are loaded and rotated through a complete range of motion for the prescribed number of cycles.

More than 400 individual quality control inspections are made on each National crane during manufacture and assembly. National attention to testing ensures that each crane delivered to the field is as close to perfect as state-of-the-art technology permits.

The National Warranty

No product is better than its warranty. And no warranty is better than the company behind it.

We didn't get to be America's largest manufacturer of truck-mounted telescoping and articulating cranes by building less than the best. Or backing them with less than a comprehensive warranty.

Our warranty covers your crane against defects in materials or workmanship for **six full months** from the date of shipment, subject to the conditions of the warranty.

When you select a National crane, you're getting more than just a crane. You're getting a nationwide dealer warranty service network, strong warranty protection and our special concern for every product we make.

Read our warranty. Then, don't settle for less. For complete information, write National Warranty Service, Waverly, NE 68462.



The National Parts System

Authorized National Crane dealers maintain a parts supply to support the National cranes in each dealer's area. If a dealer cannot immediately supply a needed part, the factory can normally provide the part to the dealer within 48 hours on request. National's responsiveness to dealer

requests means that your crane will be back on the job fast. National maintains a highly trained Service and Parts staff to answer dealer service questions and expedite parts shipping.

The National Service Center

National Crane maintains a well-equipped service center where we do all our factory crane mounting. The central location of our Service Center makes it easy to return cranes for special modifications or extreme repairs. Most National dealers can perform all but the most unusual modifications or most serious repairs.

Should you need to return your crane to us for modification, warranty repair or other service, we will give it priority care and see it's returned as soon as possible.

NEW!

75-foot, fully-hydraulic, four-section boom now available!

The 700B is now available with National's field-proven, fully-hydraulic, four-section, 75-foot boom. National pioneered the design of four-section, fully hydraulic boom technology first offering it on the Series 800 telescoping crane in 1981.

When combined with the 35-foot side-stowing jib, the 775B reaches to a height of 120 feet. All boom sections extend and retract hydraulically for greater ease in handling. At the full 120 feet, the National 775B has a capacity of 2,600 pounds. With the jib stowed and the booms fully extended to 85 feet above the ground level, the 775B will lift 8,050 pounds. The unit's maximum capacity is 33,000 pounds.

The 775B is ideal for placing materials at job sites requiring more-than-typical reach. Like all Nationals, it can be used to load, transport, and unload materials. The one-step, sequential-extension boom saves time, effort, and money. It sets up fast at the job site. There is no need for the operator to leave the controls to set up the full boom length.

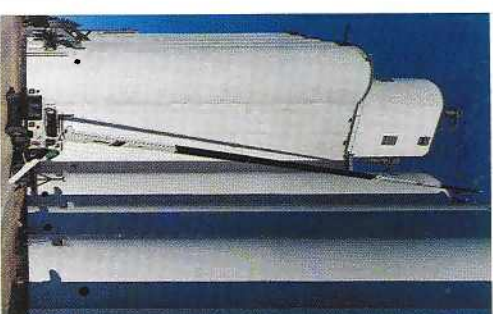

The 775B is comparatively lightweight. It requires only the basic truck mounting specifications for other 700B Series models.

The 775B's One-Step Feature:

- Fast job site set up
- No reduced capacities with booms retracted
- No need for the operator to leave the controls to set up the full boom length
- More reach
- Heavy-duty capacity
- Ability to accept jib options up to 120-foot height

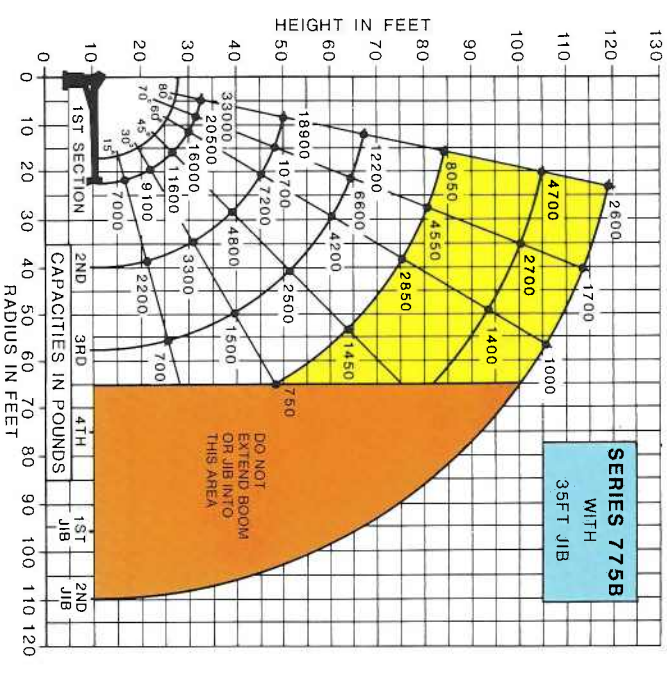

The capacities shown on this load rating chart will be reduced when the crane is equipped with jib and other boom-mounted accessories.

Do not exceed jib capacities at any reduced boom length.

Do not operate cranes or accessories within 10 feet (3m) of live power lines.

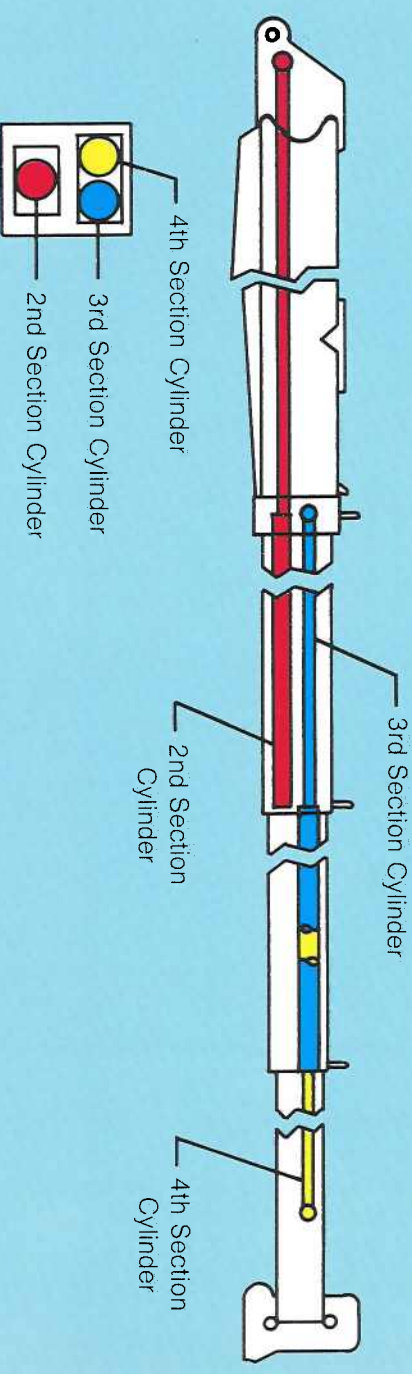

National Series 700B Booms and Jibs

Reaches to 120 feet

The National Series 700B is available with a choice of booms and jibs. One of these combinations is right for the work you do. Pick the telescoping boom you want, then add one of our jib options as a cost-efficient way to increase the capability and versatility of your Series

700B for long-reach, high capacity jobs.

The charts on this and the following page show the reaches and capacities of two popular Series 700B cranes. Your National dealer can provide information on other models.

Boom and Jib Combinations

- Telescoping Booms**
- Model 739B 22- to 39-foot two-section
 - Model 756B 22- to 56-foot three-section
 - Model 775B 22- to 75-foot four-section

- Jib Options (Side-Stowing)**
- 7FJ21 21-foot straight (for Models 739B, 756B)
 - 7FU35M 21- to 35-foot manual pull-out (for all 700B Models)

Do not operate cranes or accessories within 10 feet (3m) of live power lines.

- Load ratings shown on these charts are maximum allowable loads with the outriggers properly extended on a firm, level surface and the crane leveled and mounted on a factory-recommended truck.
- Always level the crane with the level indicator located on the crane frame.
- The operator must reduce loads to allow for factors such as wind, ground conditions, operating speeds and the effect of freely suspended loads.
- Overloading this crane may cause structural collapse or instability.
- Weights of any accessories attached to the boom or loadline must be deducted from the load chart capacities.
- Do not exceed jib capacities at any reduced boom lengths.

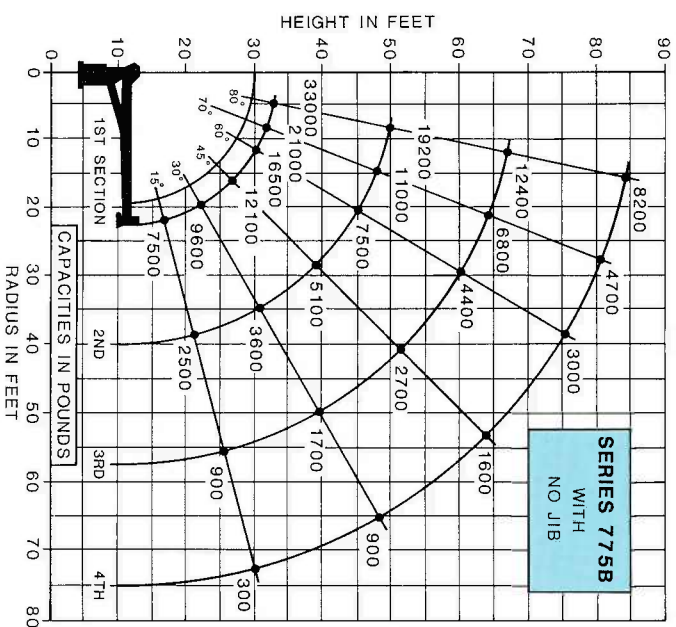

*Capacities shown are for the 775B with the load suspended; radius shown includes increase due to boom deflection. Capacities vary for cranes equipped with jibs or attachments. Consult factory for specific load rating information.

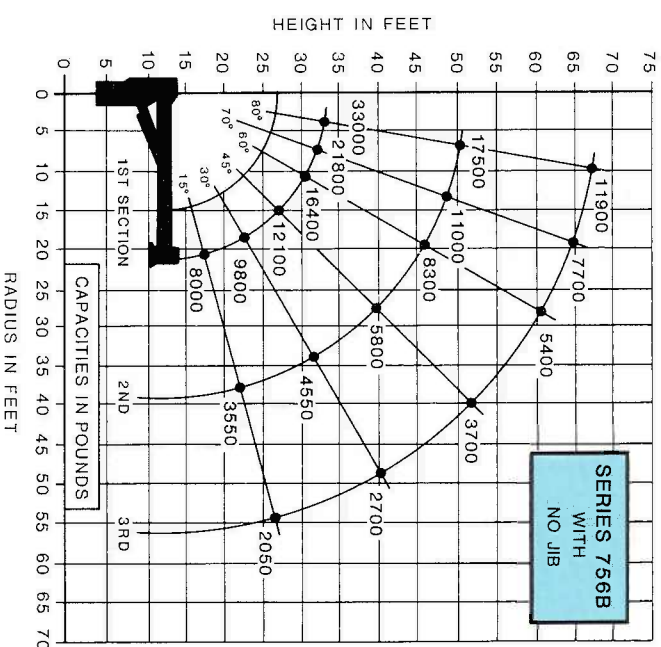

*Capacities shown are for the 756B with the load suspended; radius shown includes increase due to boom deflection. Capacities vary for cranes equipped with jibs or attachments. Consult factory for specific load rating information.

NATIONAL SERIES 700B WINCH DATA

CAUTION

- Do not deadhead lineblock against boom tip when extending boom.
- Keep at least three wraps of load line on drum at all times.
- Use only the specified cable on this machine.

Winch	Cable Supplied	Average Breaking Strength	Lift and Speed				
			1 Part Line	2 Part Line	3 Part Line	4 Part Line	5 Part Line
Standard Planetary Winch	Standard 9/16" diameter rotation resistant	35,000 lbs.	7,000 lbs. 150 fpm	14,000 lbs. 75 fpm	21,000 lbs. 50 fpm	28,000 lbs. 37 fpm	33,000 lbs. 30 fpm
			Data applies to all 700B booms				
With Optional Burst-of-Speed Feature**	Same as corresponding cable data shown above.	29,750 lbs.	7,500 lbs.* 150 fpm	15,000 lbs.* 75 fpm	22,500 lbs.* 50 fpm	30,000 lbs.* 37 fpm	33,000 lbs.* 30 fpm
			Data applies to all other Series 700B booms.				

All winch pulls and speeds are shown on the third layer (the fourth layer on 775B). Winch pulls would increase on the first and second layers. Winch line speeds would decrease on the first and second layers. Winch line pulls may be limited by the winch capacity or the cable safety factor. These are shown below.

Winch

With standard rotation resistant rope 10,200 pounds

With optional 6 x 25 IWRC rope 8,400 pounds

**This feature is available with either the standard or optional cable. Ratings are based on intermittent use. High cycle applications may require optional oil cooler.

Bare Drum Pull

Cable Pull 7,000 pounds

Allowable 8,400 pounds

Cranes are tough when they're in use, but they can be severely damaged during travel from job to job. The only way a crane can be protected from this type of wear and damage is a strong, solid, boom rest.

Boom Rests

- Add years to the life of your crane
- Reduce stress on the crane frame
- Protect rotation gear from transit damage
- Remove stress from truck frame
- Spread crane load more evenly
- Reduce maintenance and down time

In addition, boom rests are required to provide a positive way to immobilize your crane for transit.

National Crane supplies two heavy-duty boom rests for strong, sure protection of your crane. There is a quality National boom rest to fit your mounting configuration. All National Cranes must be fitted with a boom rest. All factory mounted cranes will be supplied with a boom rest.

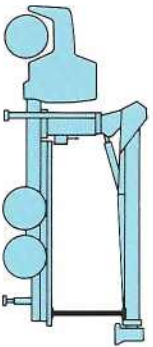

HORIZONTAL REAR BED MOUNT FOR GREATER LOAD SPACE

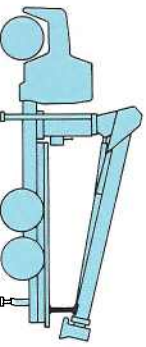

LOW-PROFILE REAR BED MOUNT FOR LOWER CENTER OF GRAVITY

Mounting Configurations

The versatility of the Series 700B can be enhanced by the mounting configurations described at the right. The configurations are based on an 85% stability factor. The complete unit must be installed in accordance with factory requirements and a test performed to determine actual stability and counterweight requirements since individual truck chassis vary.

Configuration 1 with Torsion Box

This configuration allows the installation of the 700B on a chassis with a small frame by using the standard subbase. In most cases, the chassis will not require reinforcing and the amount of counterweight required is minimized, increasing payload capabilities. Requires standard subbase, ASH rear stabilizers and usually concrete counterweight in the bed or subbase centered near the crane frame. Full capacity work area is rear 180° of vehicle from outrigger to outrigger.

Configuration 2 with Torsion Box

This mount requires front stabilizers for full capacity 360° around the truck. Front stabilizers give the machine a solid base, helping the operator control crane loads. Requires front and rear stabilizers, standard subbase with counterweight centered in the bed between the crane and the rear stabilizers. Counterweighting in this manner reduces the load induced on the front stabilizer when lifting over the front of the truck. Front stabilizers for this configuration require the following section modulus through the front suspension: 50,000 PSI-15 inch³ or 110,000 PSI-13 inch³. Extended front frame rails are recommended. Normally, a tapered front frame cannot be reinforced to these minimums. Please contact the factory.

Configuration 3 with Torsion Box

The advantages of a rear mounted Series 700B are: (1) location of the crane allows the operator to effectively use the close in working area to lift the heavier capacity loads; and (2) 360° stability at full rated load. A heavy-duty rear-mount torsion resisting subbase and hydraulic out-and-down outriggers are a necessity in this type of mount to keep the total weight of the unit to a minimum with full stability. Requires 8 HO outriggers behind cab and rear mount torsion box. 190-inch minimum distance required behind front and rear outriggers. Cab-over trucks may be used for rear mounted cranes.

Stable	180°	360°	360°
Gross Axle Weight Rating (GAWR), Front	12,000 lbs.	12,000 lbs.	12,000 lbs.
Gross Axle Weight Rating (GAWR), Rear	32,000 lbs.	32,000 lbs.	32,000 lbs.
Wheelbase (WB)	222 inches	222 inches	222 inches
Cab to axle/trunnion (CA/CT)	144 inches	144 inches	144 inches
Frame Section Modulus (SM) under crane 50,000 PSI or 110,000 PSI	32.0 inch ³ 15.9 inch ³	32.0 inch ³ 15.9 inch ³	32.0 inch ³ 15.9 inch ³
Frame Section Modulus (SM) over rear stabilizers 50,000 PSI or 110,000 PSI	15.0 inch ³ 13.0 inch ³	15.0 inch ³ 13.0 inch ³	32.0 inch ³ 15.9 inch ³
Stability Weight, Front *	6,900 lbs. minimum 7,200 lbs. maximum	6,900 lbs. minimum 7,200 lbs. maximum	7,800 lbs. minimum HO
Stability Weight, Rear *	11,200 lbs. minimum ASH	11,200 lbs. minimum ASH	7,500 lbs. minimum HO
Estimated Average Final Weight*	34,100 lbs.	34,100 lbs.	31,100 lbs.

NOTES:

- (1) GAWR means Gross Axle Weight Rating and is dependent on all components of the vehicle such as axles, tires, springs, frame, etc. meeting manufacturer's recommendations. **Always specify GAWR when purchasing trucks.**
- (2) Minimum axle requirements may increase with use of longer wheelbase, service bodies, diesel engines or front stabilizers.
- (3) Tandem axle trucks must be used for hauling larger payloads.
- (4) Diesel engines require variable speed governor and energize-to-run fuel solenoid for smooth crane operation.

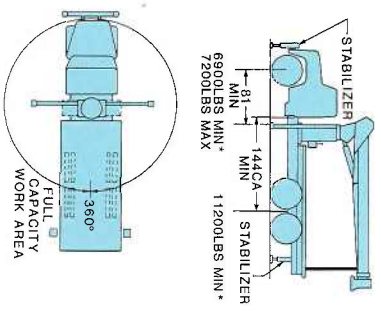
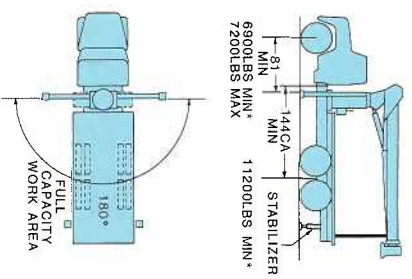

NOTE: Either dual or single front stabilizer can be used with this configuration.

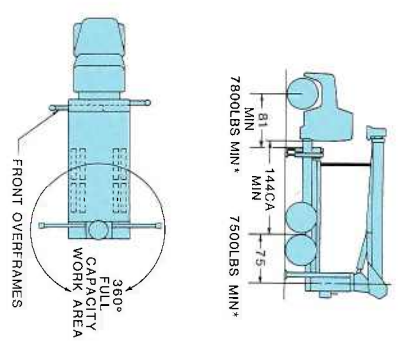

* Estimated axle scale weights prior to installation of crane and stabilizers and subbase if required for 85% stability.



National Series 700B Accessories

Every Series 700B is part of the National Lifting System.

The National Lifting System can equip your 700B to do more than just lift or handle materials. It lets you equip your truck-mounted crane to perform the functions of a whole fleet of specialized vehicles, and at a fraction of the cost.

Because your 700B can do so many jobs from start to finish, you save time, money, and manpower on almost every job you do. You'll find you can do more, faster, with less equipment. And that's money in your pocket!

Get the most from your National 700B. Make it more than just a crane with cost-efficient, hard-working accessories from the National Lift System.

Note: Weights of all accessories attached to the boom or loadline of the crane must be deducted from the effective lifting capacity.

Consult your dealer for specific accessory availability. Some accessories cannot be used in combination with other accessories and/or certain boom/jib combinations.

Caution
Do not operate crane booms, jib extensions, any accessories, or loads within 10 feet (3m) of live power lines. Do not exceed jib capacities at any reduced boom lengths.

Remote Control

National offers one-hand remote control for your Series 700B. Ideal for use where precise control and total load visibility are required.

Fine metering and instant response mean operators can position loads or work platforms easily.

National's remote controls are built with solid state circuitry and few working parts. They are designed for reliability. You will be impressed with the high operating speeds and modular design.

Available in two models: R4 with tilt, turn, telescope and winch functions, and R3 with tilt, turn, and telescope only. R3 should be used to control cranes from basket.

A priority control valve, operated by a trigger on the remote control unit, regulates oil flow and gives you fingertip speed control over all crane functions.

National's remote control is the lightweight, easy-to-use way to add extra versatility to your crane. Consult your dealer or the factory for availability.

Model R3
Tilt, turn and telescope

Model R4
Tilt, turn, telescope and winch



One Person Basket

Strong, lightweight fiberglass basket with 300-pound capacity puts personnel where you want them for tough maintenance and installation jobs. Optional dual basket bracket for two-basket operation on main boom.

(Note: Jib will accommodate only one basket.) Easy on-off. Safety belts included. With basket(s) attached to the crane, the crane must not be operated at a position where the crane load chart shows less than the following capacities:

- One fiberglass basket — 550 pounds
- Two fiberglass baskets — 1,110 pounds

Model B1
Model B1-L
With lock

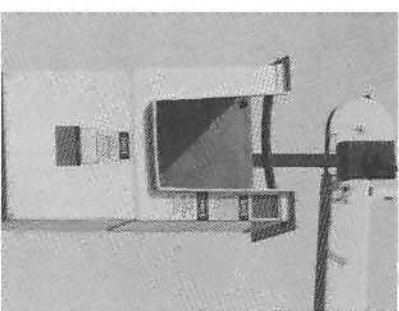

Personnel Platform

This extra strength 3 x 6-foot steel platform will carry up to 1,000 pounds and operate at working heights up to 90 feet. It is hydraulically self-leveling and protected by safety valves. Safety belts included. Fold down sides standard.

Optional manual rotator available for precise placement of the platform. Easy-to-operate crank rotates the platform through a dependable chain drive. Continuous rotation. Locks in position.

The personnel platform must not be operated in load rated areas where the load chart shows capacities less than 1,800 pounds on Model SLP and 1,900 pounds on Model SLP-R.

Model SLP
Model SLP-R

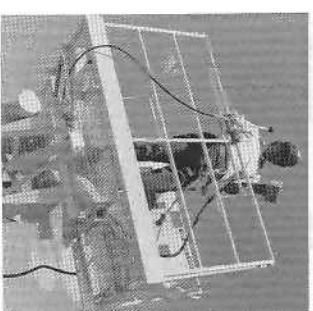

Two Person Basket

Extra capacity steel basket, swing-mounted to self-level. An adjustable, over-center, lever-operated friction brake for stability and locking.

Safety belts included. The basket must not be used in load-rated areas where the crane load chart shows capacities less than 950 pounds. The maximum capacity of the basket is 500 pounds.

Model BS-1

5-ft. yoke
Can be attached to 15-foot angling jib for additional reach.

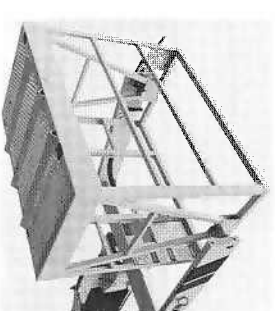

Stabilizers

We offer a complete range of front and rear stabilizers with hydraulic vertical and horizontal motion. All cylinders are fully enclosed for protection against dirt and on-the-job damage.

Stabilizers

Vertical Travel20"
Ground Penetration (38" Frame Height)8"
OperationAll-Hydraulic.....13"
Span10"

Cross-frame Outriggers

Extended Span15' 6"
Retracted Span7' 11"
Vertical Travel25"
Over-Frame18"
Under-Frame18"
Ground Penetration (38" Frame Height)10"
Mounting Space60"
Crane/Outrigger24"
Outrigger Only24"
MountingBehind cab at rear of chassis or both

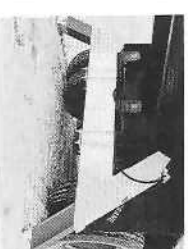

Rear Mounted
(Model ASH)

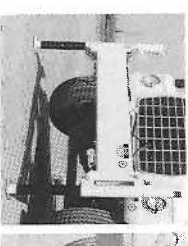

Front Mounted
(Model FSH-25 Fixed, SFO Fixed*, and Model FSHF-25 Folding)

*The SFO, a single front mounted hydraulic stabilizer, is not designed to lift the vehicle, but will provide stability for the vehicle after it has been leveled. The SFO has an 18" vertical stroke.

Loose Material

Clam Bucket
Increase the flexibility of your National crane with a National clam bucket. Use this versatile accessory to load or move up to ½ cubic yard of loose materials with each bite. Hooks easily to loadline, comes with 50 feet of hydraulic hose on automatic reel and quick-connect fittings. Extension hoses are required for use with jibs. Just position the load where you want it and open the bucket.

Model LMC



Pallet Fork

Turns your Series 700B into a versatile, payload-packing fork lift. Great for delivering palletized material right where you want it. 4,400 lbs. (1,814kg) capacity with adjustable throat and teeth. Handles most loads with ease.

Capacity:	4,400 lbs. at 20" center
Throat Opening: (adjustable)	41" to 65"
Tooth Length:	38"
Tooth Width: (outside to outside)	33.5" to 57" min. max.
Weight:	350 lbs.

Model MKF
(Manual leveling, adjustable throat)



Capacity Alert System

National offers two capacity alert options. The audible-visual capacity alert system is designed to alert the operator when he reaches a maximum capacity condition on the crane structure. This system activates the truck horn when the capacity load is exceeded on the main boom.

The hydraulic capacity alert system is a hydraulically operated, maximum capacity sensing device that is designed to stop all of the normal crane functions that cause overload when maximum capacity is exceeded on the main boom. Neither of these systems is applicable to jib and stability capacities.

Model AAS
(Audible capacity alert system)

Model HAS
(Hydraulic capacity alert system)

Three Pump System
This optional pump system provides three separate (or individual) hydraulic circuits for independent operation of winch, swing, and crane functions. The option increases productivity on high-cycle jobs and facilitates the ease of operation.

Hydraulic Oil Cooler
Automatic hydraulic device designed to cool the oil under continuous operation.
Model HOC

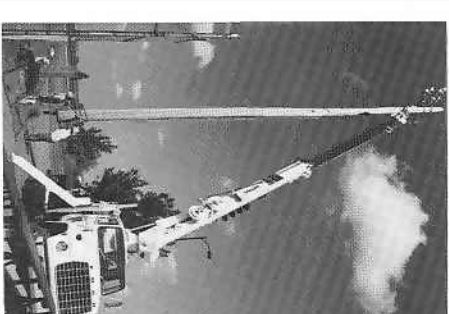

National Series 700B Specifications

General Construction

Low-alloy, high-tensile, and other steel including T-1, E-Ten, Stressproof and Hi-Yield are combined with special low-hydrogen welding techniques wherever advantageous. Standard color: painted National Ivory.

Frame:

Box construction for maximum strength and rigidity.

Turret:

Fabricated rigid structure, well-braced for stability. Line-bored and machined after welding to ensure proper alignment.

Rotation:

375° rotational force 220,000 in./lb. Turret rotation is by planetary gear motor and planetary gearbox driving a pinion. The turret rotates on a ball-bearing race. Spring-applied-hydraulic release brake provides positive, no-drift lateral positioning.

Sub-base:

Unitized box construction designed to increase torsional stiffness and reduce truck frame requirements. Standard sub-base is designed to fit on standard 34" wide truck frame and will accommodate an 18" stringerless bed. Attaches both to truck frame and crane frame. Total depth of sub-base is 10"

Outriggers:

"A" frame box-type, 18' span (center of pad at ground level) move out and down, will not bind when raising or lowering truck. Can be positioned to 9" below ground level on 38" truck frame height.

Tilt:

Double-acting hydraulic cylinder raises and lowers boom; butt-mounted safety holding valve prevents boom falling in event of hose failure. Heavy duty, long-life pivot bearings.

Boom:

Boxed construction; telescopes hydraulically in sequence under rated load on nylon plates impregnated with molybdenum disulfide for smooth, long-life operation. Boom cylinder and valves are easily serviced. Heavy-duty long-life pivot bearings.

Winch:

Hydraulic gear motor with planetary gear reduction brake and counterbalance valve for "power down" load lowering. 10,200 lbs. bare drum single-line pull available with 220 ft. of 9/16 inch, 17.5 ton breaking strength loadline. "Burst-of-Speed" control increases payout and pick-up of unloaded cable 60% over normal operating speed.

Pumps:

Two Vickers, high-pressure, high-speed balanced-vane, replaceable cartridge-type, providing 27 gpm to crane functions and 34 gpm to winch.

Cylinders:

Shaft packing: Polyurethane cup type. Shafts: HYield stress-relieved, chrome-plated. Piston sets: Polyurethane u-cups with glass-reinforced nylon bearings. Cylinder barrels: Microhones tubing and safety check valves.

Valves:

Four-way, spring-centered, spool type with low spool force and extra-fine metering notches. Independent relief valves protect hydraulic circuit against overload. Relief valves set at 2650 psi (3050 psi on winch system). Valves located for improved accessibility and easier service.

Hose:

All high-pressure hose is wire braid reinforced, having a minimum safety factor of 4 to 1.

Operating Speeds

Winch 3rd wrap: 150 fpm.
Boom up or down: 22-26 seconds; Boom out: 22 ft. to 56 ft., 70 seconds; Boom in: 56 ft. to 22 ft., 62 seconds.
Turn: 32-40 seconds. When using remote control, crane function speeds will be reduced by 40% to assure smooth operation. (Speeds above assume no load with 27 gpm oil flow on boom and 34 gpm on winch.)

Oil Tank Capacities:

60 gallon supply tank with breather, clean-out, suction strainers and removable magnetic plug

Capacity Alert Systems

Devices available to reduce possibility of operator error. See your dealer.

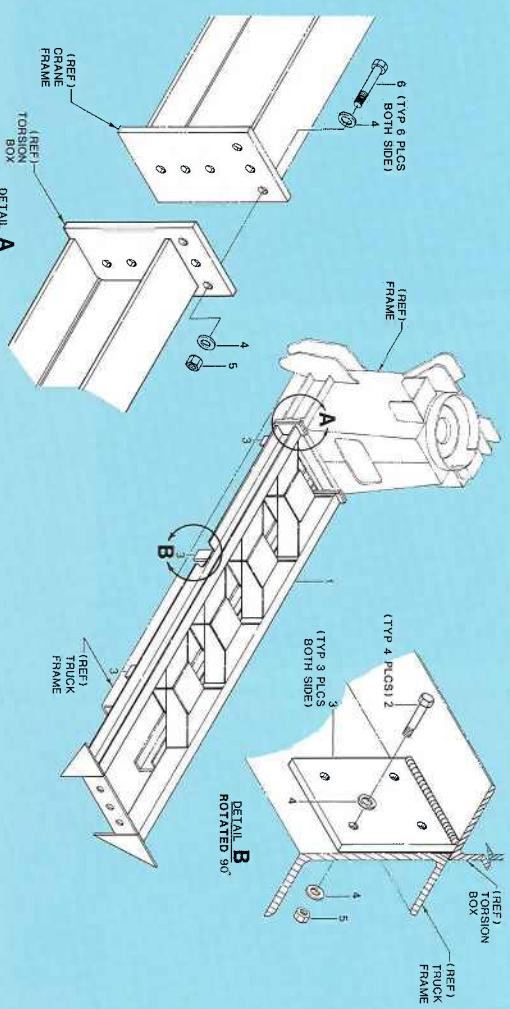

ROTATION

