

NATIONAL SERIES 600A

Truck-Mounted Telescoping Cranes and Accessories

Maximum Vertical Reach: 118 Feet (36 Meters)
Maximum Capacity: 25,000 Pounds (11.3 Metric Tons)

America's
Truck-Mounted
Hydraulic Crane
Leader

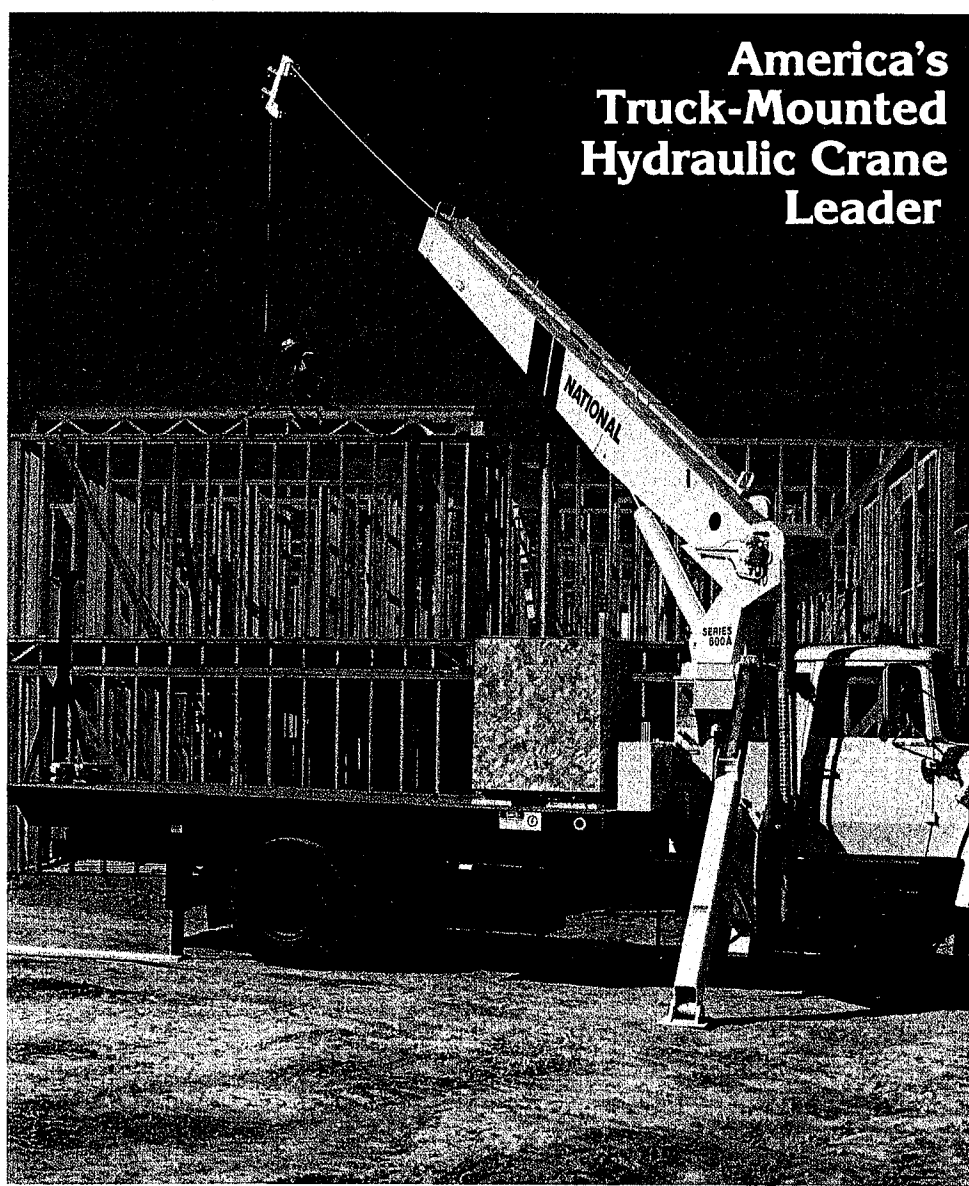

NATIONAL SERIES 600A

National is America's leading manufacturer of commercial truck-mounted telescoping and articulating cranes. We produce cranes for a wide range of jobs. Nationals are tough, durable, and dependable. And they are designed for ease of operation.

With a National, you are assured of a well-engineered, well-manufactured, and fully tested machine designed for your applications. At National, we put quality first. Our commitment to product quality is our pledge to provide our customers with reliable products designed to provide years of service.

Our Series 600A telescoping crane gives you everything you want and need in a tough, compact, 12½-ton-capacity crane. Consider these features:

- 12½-ton (12.2 MT) rated capacity
- Reaches up to 118 feet (36m) high
- Now available with 66-foot boom
- Higher capacity in normal operating areas
- Wide 18-foot (5.49m) outrigger span for greater stability
- Large bolt-in wear pads in boom last longer and are easier to replace
- Dual controls in SAE recommended orientation; each with foot throttle
- Control rods supported by nylon bearings, promoting smooth operation and serviceability
- Standard high-performance planetary winch with rotation resistant cable
- Standard anti two block feature to prevent cable damage when winching up or extending the boom without paying out the winch cable
- Planetary rotation gear box with a hydraulic release brake and slip-through feature that helps

protect the rotation system against damage from accidental side loading

- Outrigger location (behind operator) allows occasional 360° working area without front stabilizers when mounted on recommended truck
- Mounts on standard, single rear axle trucks with the versatility of five mounting configurations (Model 666A requires a tandem axle truck)
- Simple mounting; Subbase available to eliminate truck reinforcing and in many cases counterweight
- Boom pivot and hoist cylinder bearings provide longer life and lower maintenance
- Standard tandem pump system isolates winch from other crane functions to provide independent operation capability
- Horn and stop switches located at control stations
- Complete accessory line adds to versatility
- Boom access holes allow easy access to telescoping cylinder holding valves, and plumbing for serviceability
- Oil filter and control valves located externally for improved serviceability
- Precision machine level at both operating stations

National's anti two block system is standard on all National telescoping cranes (as of June 1, 1986). Photos in this brochure taken prior to that date may not show the crane equipped with the current standard anti two block protection system.

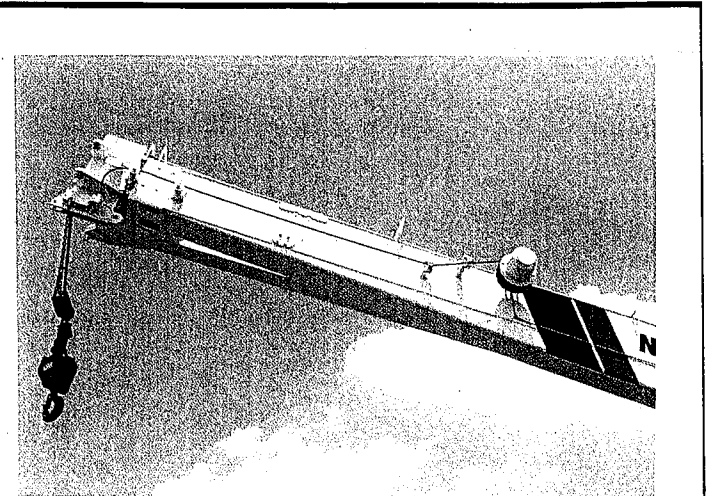
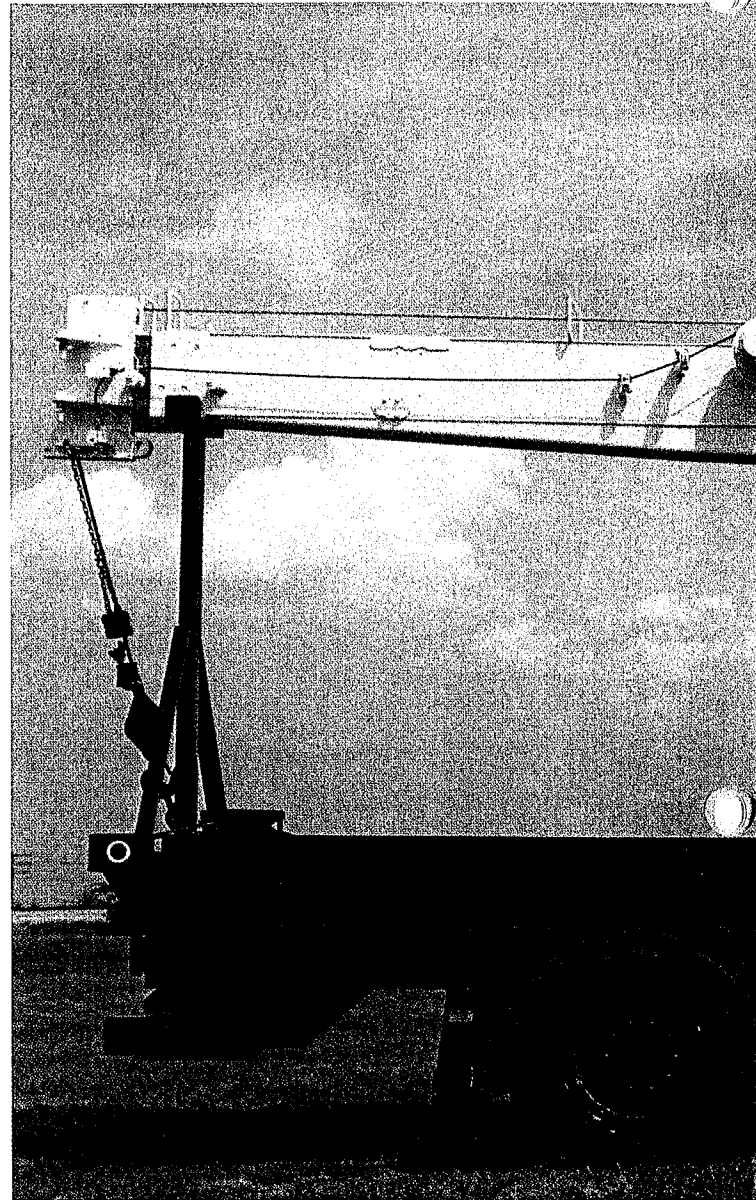

A Versatile, High-Capacity, Hydraulic Telescoping Crane from National



NATIONAL

**SERIES
600A**

The National Testing Program

National Crane established its original product durability standards by carefully evaluating the performance of competitive machines. Taking the best performances from these tests, National engineers set their own standards **more than 50% higher!** This is the same testing program each National must pass today.

Before a new model is released for production manufacturing it is subjected

to state-of-the-art testing. For example, a plastic-based "brittle lacquer" coating is applied to the boom. After loading the boom, test engineers inspect the coating for cracks. The special lacquer has virtually no elastic qualities, so stretching or deformation of the metal shows up in "fractures" of the coating, perpendicular to the direction of stretching.

This procedure indicates where engineers are to place strain gauges, tiny chips printed with electronic circuitry which expand or

contract with changes in the metal. Minute changes in electrical resistance are measured by a computerized strain gauge monitor and printed out for engineering studies: These strain gauges measure current fluctuations as small as one-millionth of an ohm—which measures metal deformation as small as one-millionth of an inch.

After strain gauge testing, the prototype of each new model undergoes life-cycle testing. The crane is operated at full-load through a full life-cycle under close

scrutiny. Outriggers, frames, and other components are loaded and rotated through a complete range of motion for the prescribed number of cycles.

More than 400 individual quality control inspections are made on each National crane during manufacture and assembly. National attention to testing ensures that each crane delivered to the field is as close to perfect as state-of-the-art technology permits.

National Series 600A

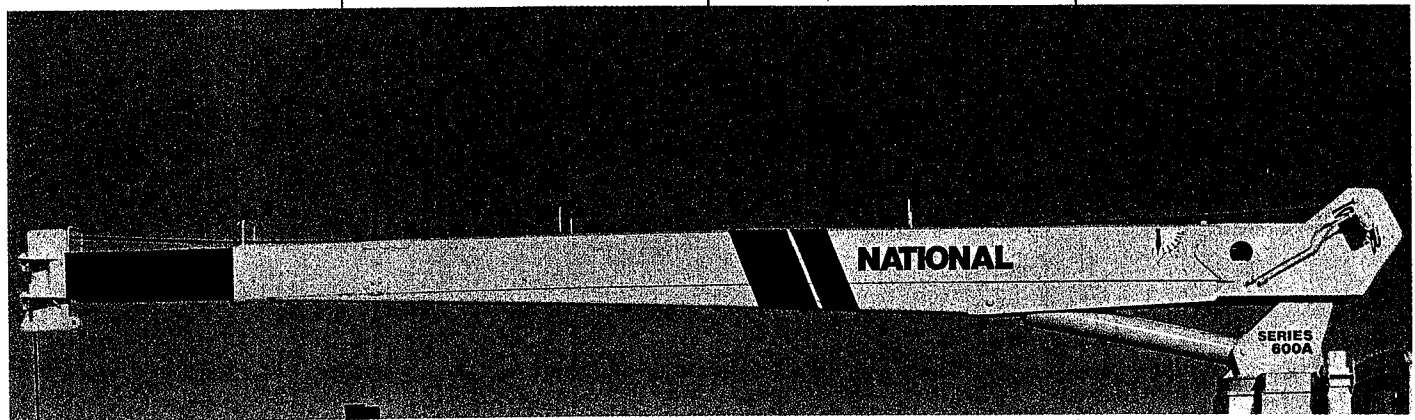

Strong Four-Plate Booms

Through computer aided design, National has removed weight from the Series 600A boom sections. We fabricate our telescoping boom sections from four high-strength steel members welded with perpendicular corners. This box-section construction lets us use thicker top and bottom plates for extra strength. The use of thinner side plates means increased capacity through lower boom weight. National has added this four-plate design to the first boom section of the 600A. Only strong, low alloy steel is used in National booms. It is welded with automatic, low-hydrogen techniques for extra strong seams. Corner seams are ultrasonically tested for proper penetration.

The National Series 600A is equipped on all sides with large nylon wear pads impregnated with lubricants which provide a smooth, long-life operation. The wear resistance of the material used in the Series 600A pads is unexcelled by competitive models.

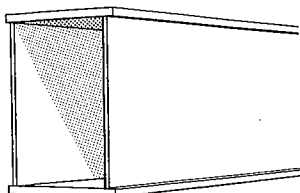

High Performance Planetary Winch

Every Series 600A comes standard with a high performance planetary gear drive winch. A "Burst-of-Speed" feature for faster, more efficient pay-out and pick-up of unloaded cable is optional. The "Burst-of-Speed" winch circuitry increases line speed up to 60% over normal.

This high capacity winch now has greater line pull and faster standard speed. For fine control, both brake and counter-balance valve are standard. The winch is filled with 9/16" diameter rotation resistant cable. See the winch data chart on page seven for further information.

Single Axle Mounting

Our wide outriggers mean the National Series 600A can be mounted on many single-axle trucks (Model 666A requires a tandem axle truck). Yet, it still meets DOT and stability standards with ease. The Series 600A crane is built to take most of the stress, not the truck. That's the kind of engineering that adds up to lower investment and longer truck life.

Less Weight

The new Series 600A is designed with wider outriggers to reduce the need for counterweight and to increase payload.

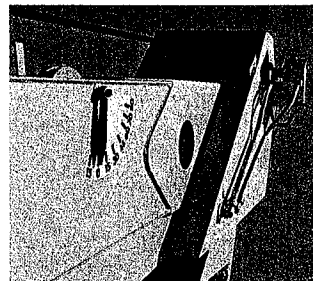

Anti Two Block

The 600A is equipped with a standard anti two block attachment. Two blocking occurs when the winch cable and attachments contact the underside of the boom sheave case, whether by winching up or extending the boom without paying out the winch cable. When this happens, the cable can be damaged by crimping or over-tensioning. The anti two block attachment prevents cable damage by sensing the position of the winch cable end attachments with respect to the sheave case and shutting down the functions that can cause two blocking.

Sequential Extension

National introduced sequential, full-load extension to the industry. Our boom sections interlock for sequential extension. The larger, stronger boom sections extend first for greater strength. National's patented locks are mechanical, not hydraulic. These field-proven locks provide reliability with no excessive noise or wasted hydraulic power. They are just one more example of how National know-how and attention to quality pays off in performance for you.

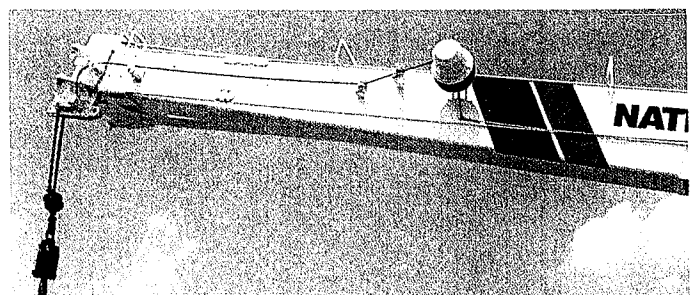
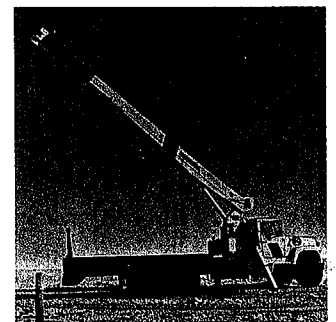

Positive Planetary Turret Rotation

The planetary rotation gearbox with a hydraulic release brake allows the gearbox to backdrive whenever excessive side load is applied to the boom, reducing shock loads on the upper and lower crane structure and gearbox. The turret drive is designed with extra heavy bearings below the drive pinion. The gearbox and rotation bearing mounting surfaces are precision machined after welding. This ensures consistent tooth alignment for smooth rotation and low wear, even under maximum loads. The entire turret glides smoothly on a low inertia ball bearing race. Rotation is 375° noncontinuous.

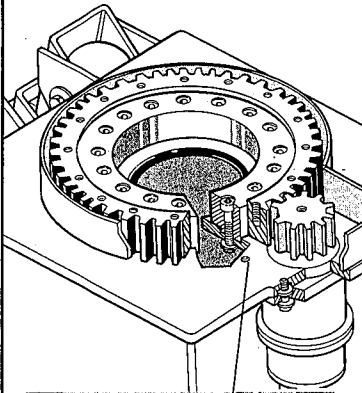

Dual Controls

Dual controls are standard on the Series 600A. The extra fine metering and low spool forces give you smoother, more precise control. Crane controls are identical on each side with SAE recommended orientation of functions. That means you always work the same control with the same hand. Dual stations provide more efficient operations and

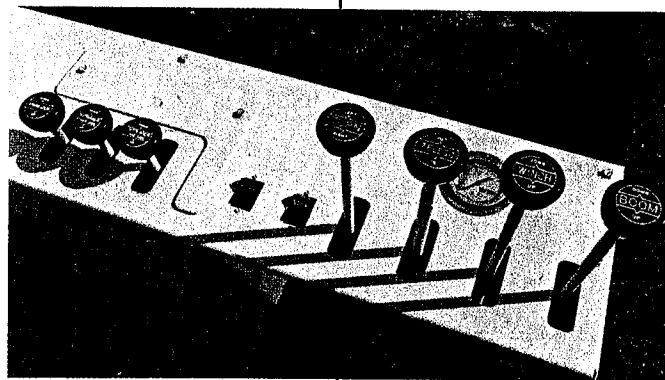

greater load visibility. Each station is equipped with kill and audible warning switches. A system pressure gauge is standard. Foot throttles allow identical foot operation of engine speed from either side. Control rods are supported by nylon bearings, promoting smooth operation and reducing lubrication requirements.

Wide Stance

We've given our new Series 600A the industry-acclaimed National out-and-down outriggers for a consistently wide stance and better leveling on uneven ground. The outriggers retract smoothly, without binding under load, first moving up,

then in. Their efficient design and wider span — 18-foot (5.49m) — gives you solid stability. With less truck weight, you can carry larger payloads more economically. A precision-mounted level indicator aids the operator in leveling the unit during the set-up procedure.

National's "Out-and-Down" Stable Outriggers

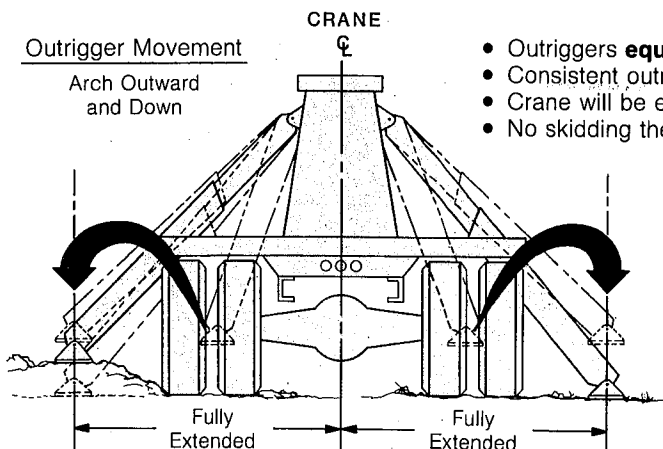

Easy Service, Low Downtime

We designed the new Series 600A with boom access holes for serviceability. The Series 600A frame allows easy access to control valves and plumbing for minor adjustments and fitting tightening. The complete console is easily removeable for major repair.

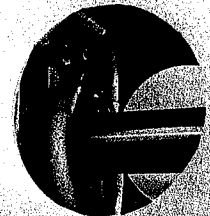

Compact Design

The National Series 600A is built tough, but compact, so it fits in just 46½ inches (1,163mm) of bed space. That leaves ample payload space, making your Series 600A even more versatile. The operator platforms are made with open-mesh expanded metal to keep dirt and mud buildup to a minimum.



National Series 600A Booms and Jibs

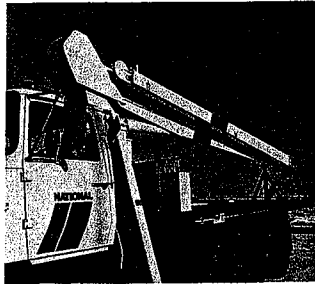

Heights to 118 feet (36m) available

The National Series 600A is available with a choice of booms and jibs. One of these combinations is right for your 12½-ton capacity lifting requirements. Select the telescoping boom you want, then add one of National's jib options as a cost-efficient way to increase the reach and versatility of your Series 600A.

The charts at right show the capacities of National's all new Series 600A telescoping cranes. Your National dealer can provide detailed information on the boom/jib combinations that are available on the 600A.

Boom and Jib Combinations

Telescoping Booms

- Model 638A: 15'8" to 38' (4.8m to 11.6m) three section
- Model 647A: 18'8" to 47' (5.7m to 14.3m) three section
- Model 656A: 21'8" to 56' (6.6m to 17.1m) three section
- Model 666A: 25' to 66' (7.6m to 20.1m) three section

Jib Options (side stowing)

- Model 6FJ15: 15' (4.6m) straight (for all models)
- Model 6FJ21: 21' (6.4m) straight (for Model 656A)
- Model 6FJ25: 25' (7.6m) straight (for Model 666A)
- Model 6FJ35M: 21' to 35' (6.4m to 10.7m) manual pull-out (for Models 656A, 666A)
- Model 6FJ42M: 25' to 42' (7.6m to 12.8m) manual pull-out (for Model 666A)

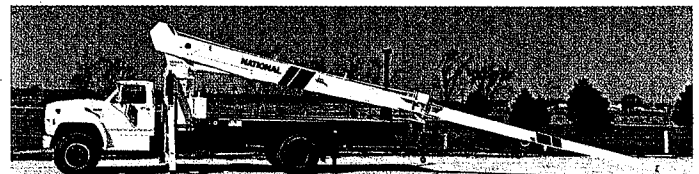
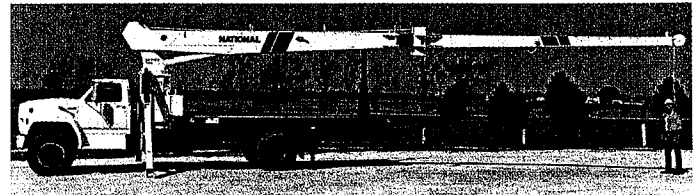
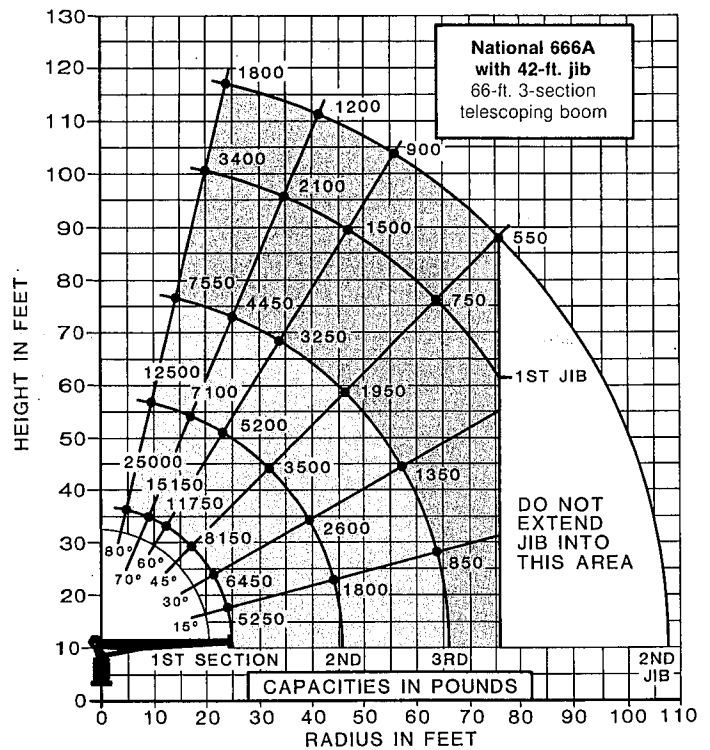

The sequence of photos above shows how a National jib folds out into working position.

Do not operate cranes or accessories within 10 feet (3m) of live power lines.

1. Load ratings shown on these charts are maximum allowable loads with the outriggers properly extended on a firm, level surface and the crane leveled and mounted on a factory-recommended truck.
2. Always level the crane with the level indicator located on the crane frame.
3. The operator must reduce loads to allow for factors such as wind, ground

conditions, operating speeds and the effect of freely suspended loads.

4. Overloading this crane may cause structural collapse or instability.
5. Weights of any accessories attached to the boom or loadline must be deducted from the load chart capacities.
6. Do not exceed jib capacities at any reduced boom lengths.

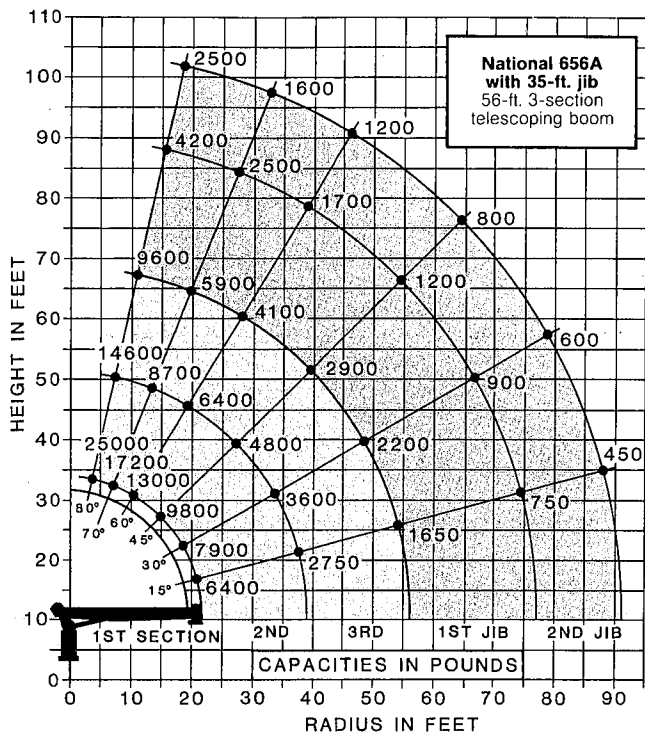

666A Capacity*

(Metric equivalents shown in parentheses)

Radius	All Booms Retracted	Second Section Extended	Third Section Extended
Maximum Capacity	25,000 lbs. (11,340kg.)		
8' (2.4m)	17,900 lbs. (8,119kg.)		
12' (3.7m)	12,600 lbs. (5,715kg.)	11,200 lbs. (5,080kg.)	
16' (4.9m)	9,700 lbs. (4,400kg.)	8,500 lbs. (3,855kg.)	7,700 lbs. (3,493kg.)
20' (6.1m)	7,600 lbs. (3,447kg.)	6,700 lbs. (3,039kg.)	6,550 lbs. (2,971kg.)
24' (7.3m)	5,700 lbs. (2,585kg.)	5,600 lbs. (2,540kg.)	5,250 lbs. (2,381kg.)
28' (8.5m)	4,700 lbs. (2,132kg.)		
32' (9.8m)	3,900 lbs. (1,769kg.)		
36' (11m)	3,300 lbs. (1,497kg.)		
40' (12.2m)	2,800 lbs. (1,270kg.)		
44' (13.4m)	2,150 lbs. (975kg.)		
48' (14.6m)	2,050 lbs. (930kg.)		
52' (15.9m)	1,850 lbs. (839kg.)		
56' (17.1m)	1,650 lbs. (748kg.)		
60' (18.3m)	1,400 lbs. (635kg.)		
64' (19.5m)	1,000 lbs. (454kg.)		

*Capacities shown are for the 666A with the load suspended, radius shown includes increase due to boom deflection. Capacities vary for cranes equipped with jibs or attachments. Consult factory for specific load rating information.

NATIONAL SERIES 600A WINCH DATA

CAUTION

Do not deadhead lineblock against boom tip when extending boom.
Keep at least three wraps of load line on drum at all times
Use only the specified cable on this machine.

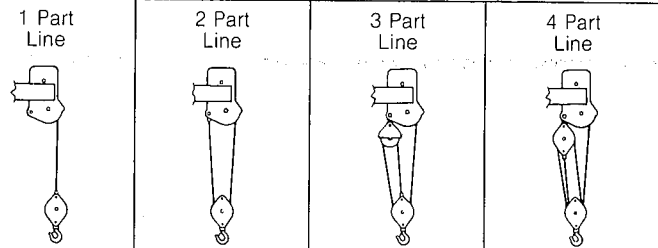

Winch	Cable Supplied	Average Breaking Strength	Lift and Speed	Lift and Speed	Lift and Speed	Lift and Speed
Standard Planetary Winch	Standard 9/16" diameter rotation resistant	35,000 lbs.	Data applies to all 600A booms.			
	Optional 9/16" diameter 6 x 25 IWRC	29,750 lbs.	7,000 lbs. 150 fpm	14,000 lbs. 75 fpm	21,000 lbs. 50 fpm	25,000 lbs. 37 fpm
			*Applicable to the 666A boom. †Applicable to all other Series 600A booms. Speeds shown are the same for all Series 600A booms.			
			7,500 lbs.* 8,400 lbs.† .150 fpm	16,800 lbs.* 16,800 lbs.† 75 fpm	25,000 lbs.* 25,000 lbs.† 50 fpm	
With Optional Burst-of-Speed Feature**	Same as corresponding cable data shown above.		3,000 lbs. 240 fpm	6,000 lbs. 120 fpm	9,000 lbs. 80 fpm	12,000 lbs. 60 fpm

All winch pulls and speeds are shown on the third layer (the fourth layer on 666A). Winch pulls would increase on the first and second layers. Winch line speeds would decrease on the first and second layers. Winch line pulls may be limited by the winch capacity or the cable safety factor. These are shown below:

Winch	Bare Drum Pull	Allowable Cable Pull
With standard rotation resistant rope	10,200 pounds	7,000 pounds
With optional 6 x 25 IWRC rope	10,200 pounds	8,400 pounds

**This feature is available with either the standard or optional cable. Ratings are based on intermittent use. High cycle applications may require optional oil cooler.

National Series 600A Truck Specifications

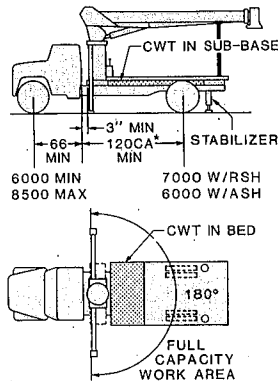
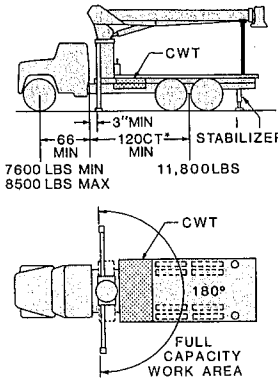
Mounting Configurations The versatility of the Series 600A can be enhanced by the mounting configurations described at the right. The configurations are based on the 656A with an 85% stability factor. The complete unit must be installed in accordance with factory requirements and a test performed to determine actual stability and counterweight requirements since individual truck chassis vary.	Configuration 1 with Torsion Box This configuration allows the installation of the 600A on a chassis with a small frame by using the standard subbase. In most cases, the chassis will not require reinforcing and the amount of counterweight required is minimized, increasing payload capabilities. Requires standard subbase, RSH rear stabilizers and usually concrete counterweight in the bed or subbase centered near the crane frame. Full capacity work area is rear 180° of vehicle from outrigger to outrigger.	Configuration 2 without Torsion Box This is the least expensive method of mounting and does not require using a subbase. However, it will require a tandem truck and in almost all cases counterweight will be needed in the bed. Requires rear stabilizers and a bed with concrete counterweight centered near the crane. Some minimum trucks also require a heavy front bumper.
Stable	180°	180°
Gross Axle Weight Rating (GAWR), Front	12,000 lbs.	12,000 lbs.
Gross Axle Weight Rating (GAWR), Rear	18,500 lbs. (34,000 for 666A)	34,000 lbs.
Wheelbase (WB)	184 inches on Models 638B, 647A; 210 inches on Models 647A, 656A; 232 inches on Model 666A	
Cab to axle/trunnion (CA/CT)	120 inches on Models 638A, 647A; 144 inches on Models 647A, 656A; 156 inches on Model 666A	
Frame Section Modulus (SM) under crane 50,000 PSI	18.0 inch ³	32.0 inch ³
-----or----- 110,000 PSI	13.3 inch ³	24.0 inch ³
Frame Section Modulus (SM) over rear stabilizers 50,000 PSI	15.0 inch ³	15.0 inch ³
-----or----- 110,000 PSI	13.0 inch ³	13.0 inch ³
Stability Weight, Front	6,000 lbs. minimum 8,500 lbs. maximum	7,600 lbs. minimum 8,500 lbs. maximum
Stability Weight, Rear	7,000 RSH	11,800 lbs. RSH
Estimated Average Final Weight	27,500 lbs.	33,500 lbs.
NOTES: (1) GAWR means Gross Axle Weight Rating and is dependent on all components of the vehicle such as axles, tires, springs, frame, etc. meeting manufacturer's recommendations. Always specify GAWR when purchasing trucks. (2) Minimum axle requirements may increase with use of longer wheelbase, service bodies, diesel engines or front stabilizers. (3) Tandem axle trucks must be used for hauling larger payloads. (4) Diesel engines require variable speed governor and energize-to-run fuel solenoid for smooth crane operation. (5) 666A requires 34,000 GAWRR and 48,000 GVWR.	 <p style="text-align: center;">*144CA MINIMUM FOR SERIES 647A and 656A</p>	 <p style="text-align: center;">CONTACT FACTORY FOR WEIGHT REQUIREMENTS *144CA MINIMUM FOR SERIES 647A and 656A</p>

Configuration 3 with Torsion Box

This mount requires front stabilizers and additional counterweight in the underside of the bed for full capacity 360° around the truck. Front stabilizers give the machine a solid base, helping the operator control crane loads. Requires front and rear stabilizers, standard subbase with counterweight centered in the bed between the crane and the rear stabilizers. Counterweighting in this manner reduces the load induced on the front stabilizer when lifting over the front of the truck. Front stabilizers for this configuration require the following section modulus through the front suspension: 50,000 PSI-15 inch³ or 110,000 PSI-13 inch³. Extended front frame rails are recommended. Normally, a tapered front frame cannot be reinforced to these minimums. Please contact the factory.

Configuration 4 with Torsion Box

The advantages of a rear mounted Series 600A are: (1) location of the crane allows the operator to effectively use the close in working area to lift the heavier capacity loads, (2) 360° solid stability at full rated load and (3) the front axle weight rating of the truck is lower than the standard behind the cab mounts. A heavy-duty rear-mount torsion resisting subbase and hydraulic out-and-down outriggers are a necessity in this type of mount to keep the total weight of the unit to a minimum with full stability. Requires 6 HO outriggers behind cab and rear mount torsion box. 190-inch minimum distance required behind front and rear outriggers. Cab-over trucks may be used for rear mounted cranes.

Configuration 5 with Torsion Box

This mount allows 360° stability at full capacity without the use of front stabilizers. It requires additional weight at the rear of the truck to reduce loading on the front axle when lifting over the front. Since the front tires are used as a stabilizing base, this mount is recommended only for the operator who **occasionally** lifts loads over the front of the vehicle. If loads are to be continually lifted around the front of the vehicle, front stabilizers are recommended to give this mount a firm base. Requires rear stabilizers and standard subbase with counterweight in subbase or underside of bed.

360°

12,000 lbs.

18,500 lbs. (34,000 for 666A)

18 inch³

13.3 inch³

15 inch³

13 inch³

6,000 lbs. minimum
8,500 lbs. maximum

8,500 lbs. RSH

29,000 lbs.

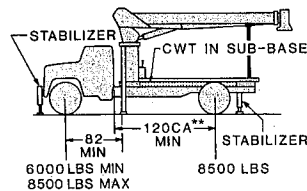

*144CA MINIMUM FOR SERIES 647A and 656A

360°

10,860 lbs.

34,000 lbs.

222 inches

144 inches

15 inch³

13.3 inch³

15 inch³

13.3 inch³

6,500 lbs.

6,500 lbs.

31,500 lbs.

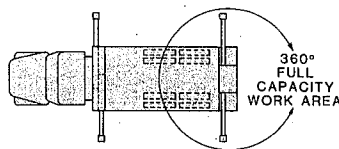
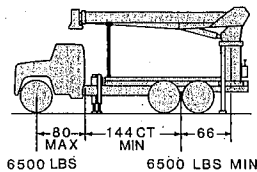

360°

12,000 lbs.

34,000 lbs.

Same as Configuration 1, 2, and 3

Same as Configuration 1, 2, and 3

18 inch³

12.3 inch³

15 inch³

13 inch³

6,000 lbs. minimum
8,500 lbs. maximum

10,000 lbs. RSH

30,000 lbs.

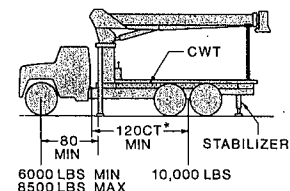

*144CT MINIMUM FOR SERIES 647A and 656A

*Estimated axle scale weights prior to installation of crane and stabilizers and subbase if required for 85% stability.

National Series 600A Boom Rests

National Warranty, Parts and Service

Cranes are tough when they're in use, but they can be severely damaged during travel from job to job. The only way a crane can be protected from this type of wear and damage is a strong, solid, boom rest.

Boom Rests

- Add years to the life of your crane
- Reduce stress on the crane frame
- Protect rotation gear from transit damage
- Remove stress from truck frame
- Spread crane load more evenly
- Reduce maintenance and down time

In addition, boom rests are required to provide a positive way to immobilize your crane for transit.

National Crane supplies five heavy-duty boom rests for strong, sure protection of your crane. There is a quality National boom rest to fit your mounting configuration. All National Cranes must be fitted with a boom rest. All factory mounted cranes will be supplied with a boom rest.

NOTE: Only shorter booms can be stowed forward.

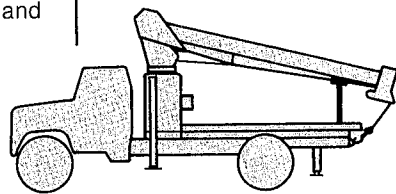

Low-profile rear bed mount for lower center of gravity

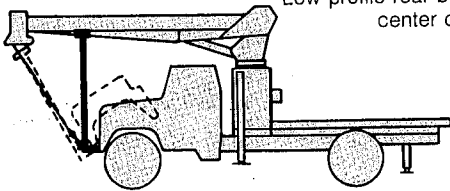

Front mount for trucks with tilting hoods

Larger Front Axle Rating Required.

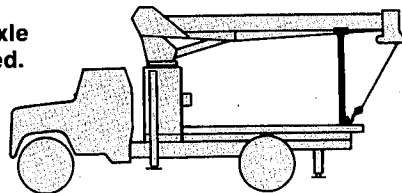

Horizontal rear bed mount for greater load space

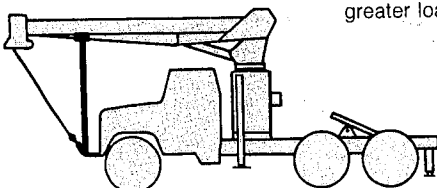

Tractor/trailer front mount

Larger Front Axle Rating Required.

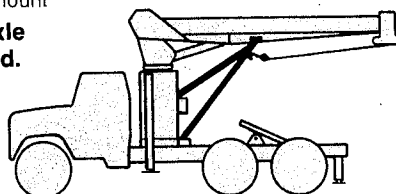

Tractor/trailer rear mount

The National Warranty

No product is better than its warranty. And no warranty is better than the company behind it.

We didn't get to be America's largest manufacturer of truck-mounted telescoping and articulating cranes by building less than the best. Or backing them with less than a comprehensive warranty.

Our warranty covers your crane against defects in materials or workmanship for **six full months** from the date of shipment, subject to the conditions of the warranty.

When you select a National crane, you're getting more than just a crane. You're getting a nationwide dealer warranty service network, strong warranty protection and our special concern for every product we make.

Read our warranty. Then, don't settle for less. For complete information, write National Warranty Service, Waverly, NE 68462.

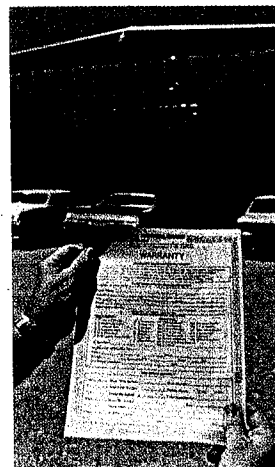

The National Parts System

Authorized National Crane dealers maintain a parts supply to support the National cranes in each dealer's area. If a dealer cannot immediately supply a needed part, the factory can normally provide the part to the dealer within 48 hours on request. National's responsiveness to dealer requests means that your crane will be back on the job fast. National maintains a highly trained Service and Parts staff to answer dealer service questions and expedite parts shipping.

The National Service Center

National maintains a well-equipped service center where we do all our factory crane mounting. The central location of our Service Center makes it easy to return cranes for special modifications or extreme repairs. Most National dealers can perform all but the most unusual modifications or most serious repairs.

Should you need to return your crane to us for modification, warranty repair or other service, we will give it priority care and see it's returned as soon as possible.

National Series 600A Accessories



Every Series 600A is part of the National Lifting System.

The National Lifting System can equip your 600A to do more than just lift or handle materials. It lets you equip your truck-mounted crane to perform the functions of a whole fleet of specialized vehicles, and at a fraction of the cost.

Because your 600A can do so many jobs from start to finish, you save time, money, and manpower on almost every job you do. You'll find you can do more, faster, with less equipment. And that's money in your pocket.

Get the most from your National 600A. Make it more than just a crane with cost-efficient, hard-working accessories from the National Lifting System.

Note:

Weights of all accessories attached to the boom or loadline of the crane must be deducted from the effective lifting capacity.

Consult your dealer for specific accessory availability. Some accessories cannot be used in combination with other accessories and/or certain boom/jib combinations.

**"Burst-of-Speed"
Planetary Winch Feature**

Enjoy the advantage of faster, more efficient pay-out and pick-up of unloaded cable with National's optional "Burst-of-Speed" high performance planetary gear drive winch. This control feature increases line speed up to 60% over normal. It is designed for intermittent use and may require optional oil cooler for high cycle applications. See the winch data chart on page 7 for further information.

Model B0S

Remote Control

National offers one-hand remote control for your Series 600A. Ideal for use where precise control and total load visibility are required.

Fine metering and instant response mean operators can position loads or work platforms easily.

National's remote controls are built with solid state circuitry and few working parts. They are designed for reliability. You will be impressed with the high operating speeds and modular design.

Available in two models: R4 with tilt, turn, telescope and winch functions, and R3 with tilt, turn, and telescope only. R3 should be used to control cranes from basket.

A priority control valve, operated by a trigger on the remote control unit, regulates oil flow and gives you fingertip speed control over all crane functions.

National's remote control is the lightweight, easy-to-use way to add extra versatility to your crane. Consult your dealer or the factory for availability.

Model R3

Tilt, turn and telescope

Model R4

Tilt, turn, telescope and winch

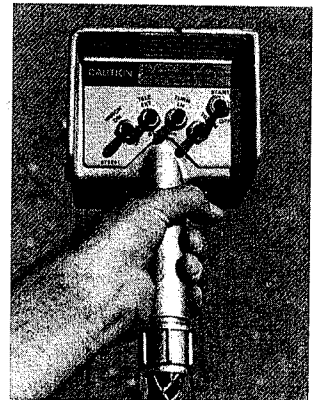

Do not operate cranes or accessories within 10 feet (3m) of live power lines.

(continued on page 12)

National Series 600A

Accessories (continued from page 11)

One Person Basket

Strong, lightweight fiberglass basket with 300-pound capacity puts personnel where you want them for tough maintenance and installation jobs. Optional dual basket bracket for two-basket operation on main boom. (Note: Jib will accommodate only one basket.) Easy on-off. Safety belts included. With basket(s) attached to the crane, the crane must not be operated at a position where the crane load chart shows less than the following capacities:

- One fiberglass basket — 550 pounds
- Two fiberglass baskets — 1,100 pounds

Model B1
Model B1-L
With lock

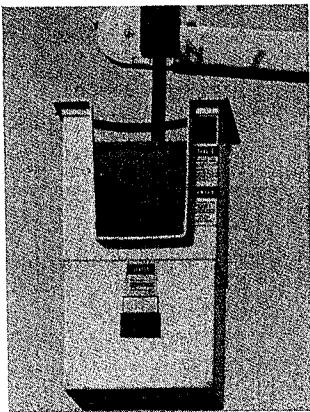

Personnel Platform

This extra strength 3 x 6-foot steel platform will carry up to 1,000 pounds and operate at working heights up to 80 feet. It is hydraulically self-leveling and protected by safety valves. Safety belts included. Fold down sides standard.

Optional manual rotator available for precise placement of the platform. Easy-to-operate crank rotates the platform through a dependable chain drive. Continuous rotation. Locks in position.

The personnel platform must not be operated in load rated areas where the load chart shows capacities less than 1,800 pounds on Model SLP and 1,900 pounds on Model SLPR.

Model SLP
Model SLPR



Pallet Fork

Turns your Series 600A into a versatile, payload-packing fork lift. Great for delivering palletized material right where you want it. 4,400 lbs. (1,814kg) capacity with adjustable throat and teeth. Handles most loads with ease.

Capacity: 4,400 lbs. at 20" center

Throat Opening: 41" to 65" (adjustable)

Tooth Length: 38"

Tooth Width: 33.5" to 57" (outside to min. max. outside)

Weight: 350 lbs.

Model MKF
(Manual leveling, adjustable throat)



Loose Material Clam Bucket

Increase the flexibility of your National crane with a National clam bucket. Use this versatile accessory to load or move up to 1/2 cubic yard of loose materials with each bite. Hooks easily to loadline, comes with 50 feet of hydraulic hose on automatic reel and quick-connect fittings. Extension hoses are required for use with jibs. Just position the load where you want it and open the bucket.

Model LMC

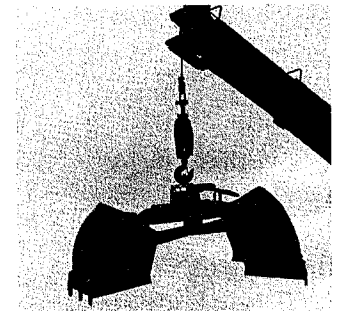

Caution

Do not operate crane booms, jib extensions, any accessories, or loads within 10 feet (3m) of live power lines. Do not exceed jib capacities at any reduced boom lengths.

Two Person Basket

Extra capacity steel basket, swing-mounted to self-level. An adjustable, over-center, lever-operated friction brake for stability and locking. Safety belts included. The basket must not be used in load-rated areas where the crane load chart shows capacities less than 950 pounds. The maximum capacity of the basket is 500 pounds.

Model BS-1
5-ft. yoke

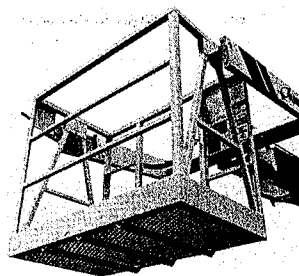

Hydraulic Oil Cooler

Automatic hydraulic device designed to cool the oil under continuous operation.

Model HOC

Three Pump System

This optional pump system provides three separate (or individual) hydraulic circuits for independent operation of winch, swing, and crane functions. The option increases productivity on high-cycle jobs and facilitates the ease of operation.

Stabilizers

We offer a complete range of front and rear stabilizers with hydraulic vertical and horizontal motion. All cylinders are fully enclosed for protection against dirt and on-the-job damage.

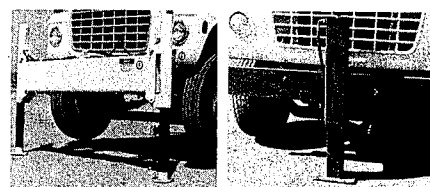
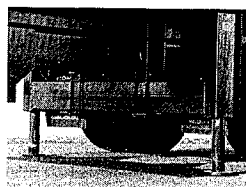
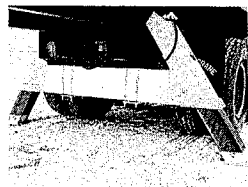

Stabilizers

Rear Mounted
(Models RSH-15/18/25)

Rear Mounted
(Model ASH)

Front Mounted
(Model FSH-25 Fixed, SFO Fixed*,
and Model FSHF-25 Folding)

Vertical Travel	15", 18" or 25"	20"	25"
Ground Penetration (38" Frame Height)	3", 6" or 13"	8"	13"
Operation	All-Hydraulic	All-Hydraulic	All-Hydraulic
Span	6' (RSH-15) 8' (RSH-18/25)	10'	8'

Controls

All stabilizers noted above can be operated from either crane control station

Cross-frame Outriggers

Extended Span	15' 6"
Retracted Span	7' 11"
Vertical Travel	
Over-Frame	25"
Under-Frame	18"
Ground Penetration (38" Frame Height)	10"
Mounting Space	
Crane/Outrigger	60"
Outrigger Only	24"
Mounting	Behind
	cab. at rear of
	chassis or both

*The SFO, a single front mounted hydraulic stabilizer, is not designed to lift the vehicle, but will provide stability for the vehicle after it has been leveled. The SFO has an 18" vertical stroke.

Hydraulic Tilting Pole Grab

This hydraulic tilting pole grab is the ideal companion accessory for your National self-stowing auger. It attaches to the end of the third boom section to steady poles and makes setting them faster and easier.

The pole grab will grip poles from 7- to 20 inches in diameter and tilts from 45° to 70° for precise placement. Tilt and grab functions are controlled by separate controls operating separate hydraulic cylinders. The unit pins easily and quickly in place. Comes complete with all controls, hoses, and hose feeder assembly.

Model PG



Two-Speed Self-Stowing Auger

Our 2-speed hydraulic auger locks onto the outer end of your second boom, giving you digging depths up to 12 ft. in a 38 ft. radius (with 56 ft. boom). When stowed, the unit locks to the first boom section, freeing the second and third for other work.

This heavy-duty auger gives you the choice of high speed/low torque or low speed/high torque digging. Selection of the proper mode for soil and digging conditions is easy and flightings are available up to 36 inches. All feed lines are fully protected and designed to work without kinking, twists or tension. (Not available with 66 ft. boom.)

Capacity Alert Systems

National offers two capacity alert options. The audible-visual capacity alert system is designed to alert the operator when he reaches a maximum capacity condition on the crane structure. This system activates the truck horn when the capacity load is exceeded on the main boom.

The hydraulic capacity alert system is a hydraulically operated, maximum capacity sensing device that is designed to stop all of the normal crane functions that cause overload when maximum capacity is exceeded on the main boom. Neither of these systems is applicable to jib and stability capacities.

Model AAS
(Audible capacity alert system)

Model HAS
(Hydraulic capacity alert system)

National Series 600A Specifications

General Construction:

Low-alloy, high-strength steel, including T-1, Ex-Ten. Stressproof, Hi-Yield, and other steels combined with special, low-hydrogen welding techniques wherever advantageous. Standard color: painted *National Ivory*.

Frame:

Box construction bolt-on truck frame mounting brackets and bolt-on subbase attachment. Rotation bearing, gearbox, and level indicator mounting surfaces are precision machined after welding to ensure accurate alignment and flat surfaces for prolonged life.

Turret:

Fabricated, rigid structure, well-braced for stability. The bearing surface is machined and the pin holes are bored after welding to ensure accurate alignment and flat surfaces for prolonged life.

Rotation:

375° noncontinuous. Rotational force 224,000 in./lbs. (670,000 in./lbs. breaking strength). Turret rotation is by hydraulic orbit motor and planetary gearbox driving a pinion. The turret rotates on a ball bearing race. Spring-applied hydraulic release brake provides positive, no-drift lateral positioning.

Outriggers:

"A" frame box-type 18-foot span (center of pad at ground level) moves out-and-down, will not bind when raising or lowering truck. Can be positioned to 8 inches below ground level when mounted on truck with a frame height of 38 inches. Outrigger cylinders are equipped with butt-mounted, safety check valves.

Lift:

Double-acting hydraulic cylinder raises and lowers the boom; butt-mounted,

safety holding valve prevents the boom from falling in the event of hose failure. Tough, field-tested bearings in tilt cylinder and boom pivot combined with micro-honed pins provide long life with reduced maintenance.

Boom:

Boxed construction. Telescopes hydraulically in sequence under rated load on nylon plates impregnated with molybdenum disulfide on all sides of boom, permitting maximum loads to be extended at greater radii. Holding valve prevents retraction except under power.

Controls:

Dual side, stand-up, with operator platform and foot accelerator identical on both sides. Simultaneous operation of load-line and other operations standard. Horn and stop switch on both sides. Controls easily removable for maintenance.

Winch

Hydraulic gear motor with planetary gear reduction, brake, and counterbalance valve for "power down", load lowering.* 10,000-pound bare drum, single line pull available with 280 feet (on 666A; 220 feet on all other booms) of 9/16" diameter, 35,000-pound breaking strength on the standard rotation resistant loadline. Optional 9/16" diameter, 29,750-pound breaking strength 6x25 IWRC loadline is available. Optional "Burst-of-Speed" control increases pay-out and pick-up of cable 60% over normal operating speed with maximum rated single line pull of 3,000 pounds.

*Because of ANSI safety factor requirements, the standard rotation resistant wire rope is rated at a 7,000-pound, 5:1, single line pull and the optional 6x25 IWRC wire rope is rated at an 8,400-pound, 3.5:1, single line pull.

Pump:

One Vickers, high-pressure, high speed, balanced vane, replaceable cartridge-type tandem pump independently providing 34 gpm to winch, and 23 gpm to crane for smooth, fast, simultaneous operation.

Cylinders:

Shaft packing: Polyurethane U-cup type. Shafts Hi-Yield, stress-relieved, chrome-plated. Piston sets: Polyurethane U-cup and rider construction. Cylinder barrels: Micro-honed tubing, butt-mounted, safety check valves.

Valves:

Four-way, spring-centered, spool-type with independent relief valves set at 2,550 psi (maximum 3,050 psi on winch system) to protect circuits against overload.

Hose:

All high-pressure hose is wire-braid reinforced, having a minimum safety factor of 4 to 1.

Operating Speeds:

Winch third layer speed: 150 fpm. Rotation 375°, 40-45 seconds. Boom up, -10° to 80°, 16 seconds. Boom down, 80° to -10°, 12 seconds. Boom extend: 53 fpm. Boom retract: 64 fpm. When using remote control, crane function speeds will be reduced by 50% to assure smooth operation. (Speeds above assume no load with 23 gpm oil flow on boom and 34 gpm on winch.)

Oil Tank Capacities:

60-gallon supply tank. Normally mounted on subframe. Sight gauge, breather, suction strainer, clean-out, and magnetic plug.

Filter:

10-micron, replaceable-cartridge, return-line filter. 100% filtration.

Capacity Alert Systems:

Devices available to reduce possibility of operator error. See your dealer.

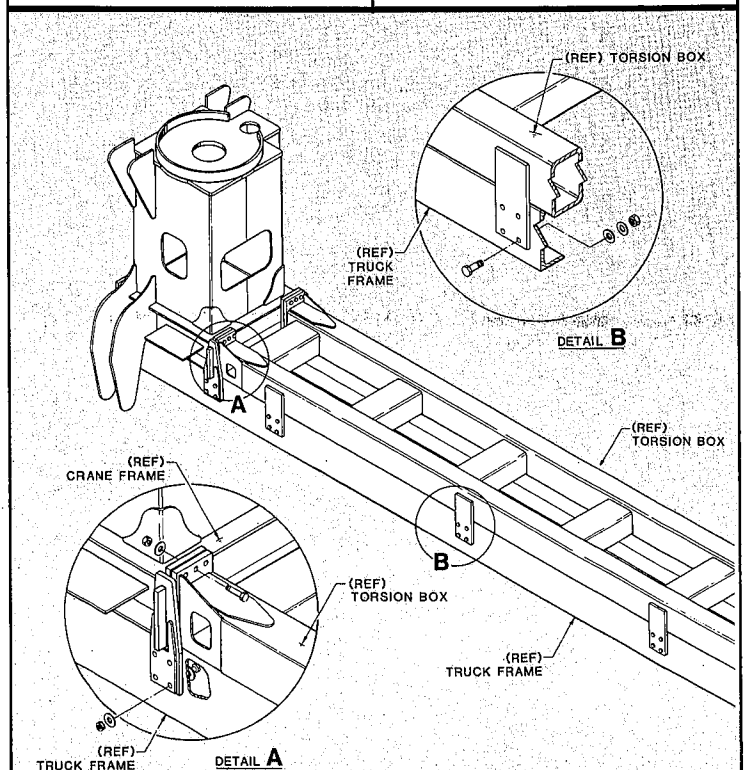

G. CENTER OF GRAVITY

Series	RL	EL	G	*Dry Weight	*W/Oil Weight
666A	25'	66'	60"	10,600 lbs.	11,000 lbs.
656A	21'8"	56'	47"	10,000 lbs.	10,400 lbs.
647A	18'8"	47'	37"	9,500 lbs.	9,900 lbs.
638A	15'8"	38'	30"	9,000 lbs.	9,400 lbs.

*Above weights do not include subbase or rear stabilizers.
 The standard subbase weight is 1,150 pounds.
 The rear stabilizer (RSH 18") weight is 550 pounds.
 The subbase dimension is: 34" wide by 216" long by 9" high.

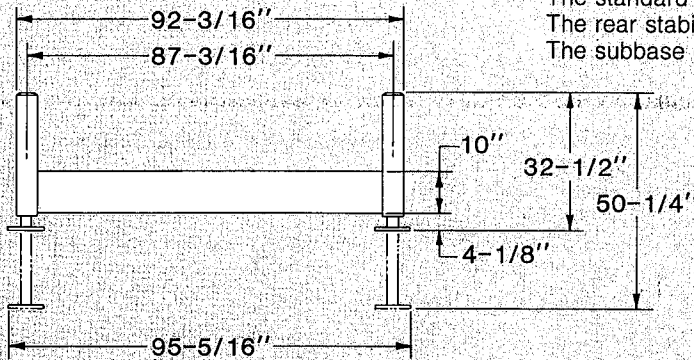

**REAR STABILIZER
(RSH 18")**

