

National Series 500B Buyer's Guide

Truck-Mounted Telescoping Cranes and Accessories

Maximum Height: 118 Feet (36 Meters)

Maximum Capacity: 25,000 Pounds (11.3 Metric Tons)

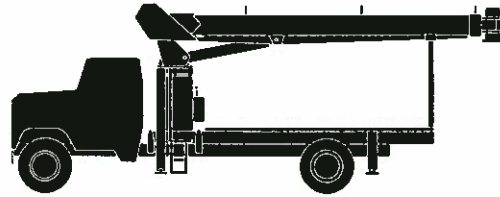

America's Truck-Mounted Hydraulic Crane Leader

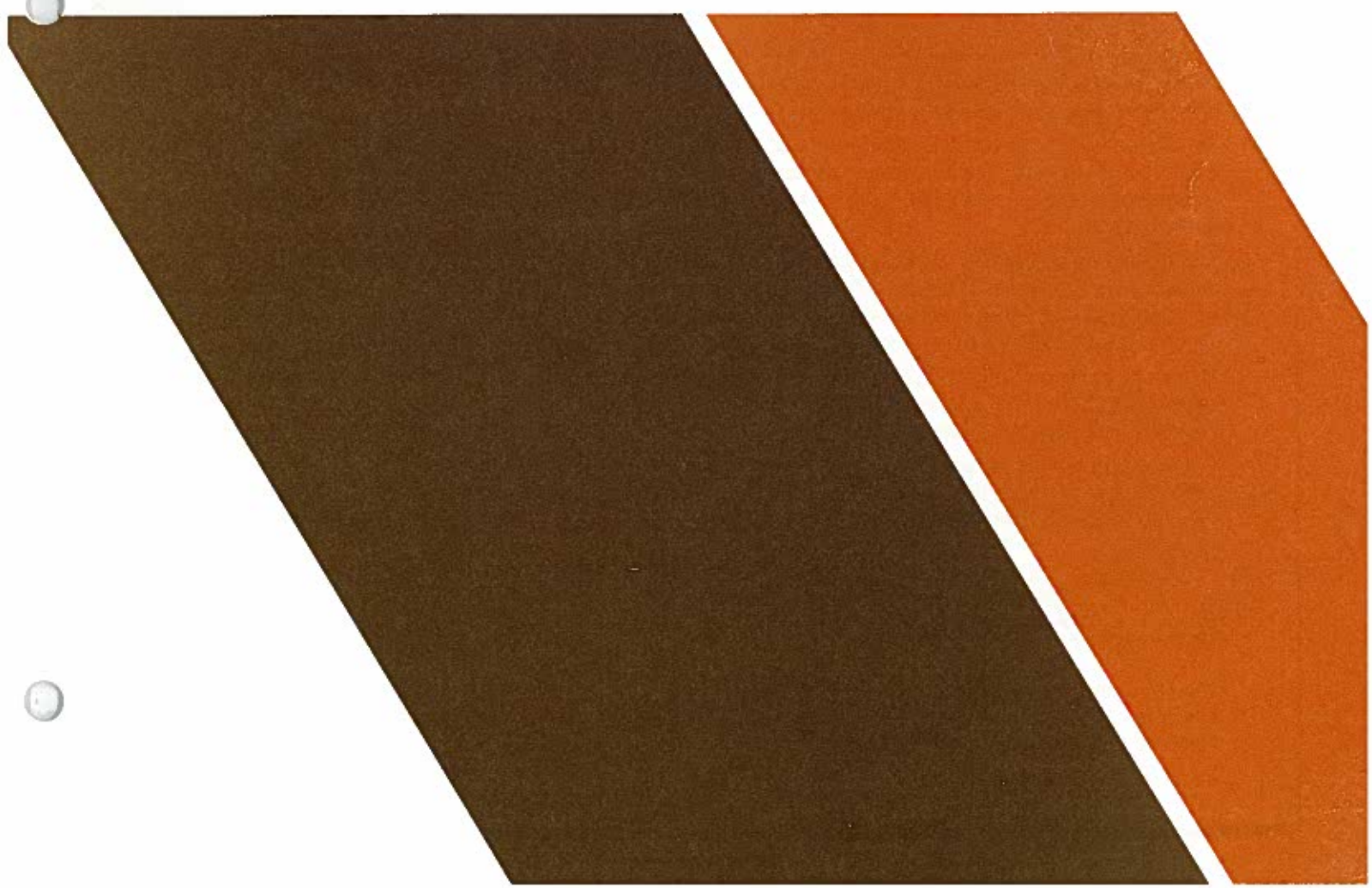

National Series 500B



Dear Crane User:

National Crane Corporation values your goodwill. We have developed our engineering, manufacturing, sales and service programs with you — our customer — in mind.

This Series 500B Buyer's Guide provides you with technical data and other considerations that will give you an informational base to make a sound and sensible buying decision. We encourage you to compare the technologies, capabilities and other benefits that National Crane offers against those of competitive manufacturers. We are confident that when you are equipped with all of the facts, National will be your brand of preference.

Our heavy-duty Series 500B offers a vertical reach of 118 feet, a rated capacity of 25,000 pounds, a wide choice of mounting configurations (many on single axle trucks), and a selection of jibs and other optional equipment.

National has been in business, manufacturing truck-mounted hydraulic telescoping and articulating cranes, for a full quarter-century. We have earned our reputation for quality through performance — through sound, sensible engineering and the manufacture of durable, user-oriented cranes that meet the most stringent on-the-job demands. The new Nationals combine time-proven strengths and exciting new technologies that afford greater vertical reach than ever before, and more lift, particularly in areas where capacity really counts.

Our cranes are subjected to the industry's most demanding testing program. Each crane undergoes quality inspections at all levels of the manufacturing and assembly process. We like to think that National's emphasis on quality is a key reason our cranes have, traditionally, retained the highest market value among comparable products year after year.

We offer strong warranty protection. Moreover, when you buy a National, you receive support from our outstanding network of dealers. Working with National, they are responsive to your parts and repair requirements. National's emphasis on customer service and responsiveness is unexcelled in the industry.

For these, and other reasons, National is touted as America's truck-mounted crane leader. We hope that you will take your cue from the some 17,000 demanding users who have purchased Nationals over the past 25-plus years. Read the information that follows carefully. I am confident that you will be impressed.

Sincerely,

Ted Urbanek
President
National Crane Corporation

A high-capacity, hydraulic telescoping crane from National



National Series 500B

The National Testing Program

National Crane established its original product durability standards by carefully evaluating the performance of competitive machines. Taking the best performances from these tests, National engineers set their own standards **more than 50% higher!** This is the same testing program each National must pass today.

Before a new model is released for production manufacturing it is subjected to state-of-the-art testing. For example, a plastic-based "brittle lacquer" coating is

applied to the crane. After loading, test engineers inspect the coating for cracks. The special lacquer has virtually no elastic qualities, so stretching or deformation of the metal shows up in "fractures" of the coating, perpendicular to the direction of stretching.

This procedure indicates where engineers are to place strain gauges, tiny chips printed with electronic circuitry which expand or contract with changes in the metal. Minute changes in electrical resistance are

measured by a computerized strain gauge monitor and printed out for engineering studies. Strain gauges measure metal deformation as small as one-millionth of an inch.

After strain gauge testing, the prototype of each new model undergoes life-cycle testing. The crane is operated at full-load through a full life-cycle under close scrutiny. Outriggers, frames, and other components are loaded and rotated through a complete range of motion for the prescribed number of cycles.

All components used on National cranes are subject to

a multi-level inspection program during manufacture and assembly. National's attention to testing ensures that each crane delivered to the field is ready for on-the-job action.



National Series 500B



National Crane, America's truck-mounted hydraulic crane leader, manufactures an extensive line of telescoping and articulating cranes. The **Series 500B**, a medium-to-heavy-duty telescoping crane, is the product of National's field-proven know-how and pacesetter new technologies. Here are some of the reasons that you should "think National" when buying a medium-to-heavy-duty telescoping crane to serve your lifting needs:

Why buy a National Series 500B?

- The Series 500B provides you with solid lifting power and extra-long hydraulic reach. The rated capacity is **25,000 pounds**. The 66-foot all-hydraulic boom reaches vertically to **76-feet** (and to **118-feet** with the optional 42-foot jib).
- The Series 500B offers you field-proven quality, backed by National's more than **25 years** of manufacturing excellence. Buy with confidence. Take your cue from the 17,000 demanding users who have put National cranes to the test over the past 25 years.
- Nationals are durable. Nearly 90% of all National cranes ever manufactured are working on the job today.
- The value of a National crane traditionally remains high year after year. The Series 500B is a solid, enduring, cost-efficient investment.
- All National cranes, including the 500B, are subjected to the industry's most rigorous, demanding testing.
- The Series 500B undergoes detailed inspections at all levels of manufacturing and assembly processes.
- All structural welders at National must pass AWS welder certifications.
- Component manufacturers are subjected to critical review by National's senior management before they can qualify as a supplier of National crane parts.
- Inspections of incoming material and components ensure that purchased items will perform as expected.
- Material certifications are maintained and steel composition is regularly verified.
- All tooling and instruments are calibrated and verified to ensure parts consistency.
- The Series 500B is backed by strong warranty protection (covering defects in materials and workmanship for **six months** from the date of shipment).
- When you purchase a 500B, you get committed sales and service support from National's professional, well-trained nationwide dealer network.
- You receive responsive parts and repair service from your authorized National dealer and the factory. If your dealer cannot immediately supply a needed part, the factory maintains a back-up program providing 24-hour parts shipping in 90% of all breakdown rush orders. Your needs are National's first concern.
- National's box-section boom design utilizes thicker top and bottom plates to enhance boom strength and thinner side plates to increase the crane capacity through lower boom weight.
- Proportional boom design provides more efficient boom weight distribution. This maximizes boom operational efficiency and allows higher capacities (particularly in normal working radii). The design permits minimum overlap to get the most reach with minimum retracted length for maneuverability. The use of cable (rather than chain) means longer service life and less maintenance.
- Large bolt-in wear pads are easier to replace and provide longer, more durable service.
- Control rods supported by nylon bearings permit smooth, low-maintenance operation of the crane.
- Rotation resistant cable provides tangle-free, multi-part loadline applications. It restricts wire rope spinning, resulting in better load control.
- National's standard anti-two-block system helps prevent cable damage when winching up or extending the boom without paying out the winch cable.
- The 500B's angle indicator is easy to read and readily visible. It allows the operator to determine the boom angle during crane operation.
- The standard tandem vane pump isolates the winch from other crane functions, providing independent operation capability. The vane pump is more efficient and less costly to repair than gear pumps used by some manufacturers.
- National's unique "tab and slot" shear plate mounting is a strong and secure method of mounting a crane to a truck.
- The pressure gauge on the operator's console permits the operator to monitor the hydraulic system pressure to ensure maximum performance.
- The 500B's operator's platform is positioned to give the operator excellent visibility of the load as well as convenient access to the truck bed.
- The 500B's rotation stop design eliminates the sudden stop on non-continuous rotation machines by gradually slowing the rotation of the boom.
- The aluminized hydraulic reservoir prevents the gathering of rust in the system, keeping the hydraulic oil clean.
- The outrigger and stabilizer hydraulic power is sufficient to allow the leveling of a fully-loaded truck and still not lock up in the air.
- The 500B provides a precise machine leveling indicator. The level bubble bracket is machined to be parallel with the turntable bearing to indicate whether the unit is level during crane operation.
- Labeled control knobs make it easy for the operator to determine the function of each control.
- Turret and winch rotation indicators allow the operator to readily determine that the winch drum is rotating and the degree of rotation at which the boom has been positioned.
- The turntable bearing full-circle bolt pattern provides longer bearing life due to uniform loads on the bearing.
- National's planetary rotation gear box design includes a hydraulic release brake and a "slip-through" feature that helps protect the rotation system against damage from accidental side loading.

These advantages plus National's heavy-duty A-frame out-and-down outriggers with an 18-foot span for stability, dual controls in SAE orientation, and the high-performance planetary winch make the Series 500B an excellent choice for your medium-to-heavy-duty lifting requirements.

National Series 500B

Strong Four-Plate Booms

Through computer aided design, National has improved the weight efficiency of the Series 500B boom sections. We fabricate our telescoping boom sections from four high-strength steel members welded with perpendicular corners. This box-section construction lets us use thicker top and bottom plates for extra strength. The use of thinner side plates means increased capacity through lower boom weight. Only strong, low-alloy steel is used in National booms. It is welded with automatic, low-hydrogen techniques for extra strong seams. Corner seams are ultrasonically tested for proper penetration.

The National Series 500B is equipped on all sides with large nylon wear pads impregnated with lubricants, providing a smooth, long-life operation. The wear resistance of the material used in the Series 500B pads is unexcelled by competitive models.

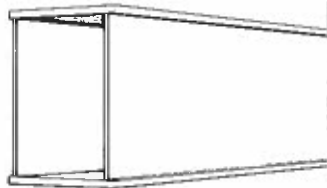

Proportional Boom Extension

Proportional (cable crowd) boom design (each boom section extends and retracts proportionally during the telescoping operation) provides more efficient boom weight distribution. This means smoother, more efficient boom operation and higher capacities for you. Since the system utilizes only one extend cylinder, hydraulic maintenance is minimized. Boom telescope cylinder is fully protected with a direct mount holding valve.



High Performance Planetary Winch

The 500B comes standard with a high-performance planetary gear drive winch. Anti-friction bearings are used throughout to maximize efficiency and seal life. A winch drum rotation indicator has been added. A "Burst-of-Speed" feature for faster, more efficient pay-out and pick-up of unloaded cable is optional. The "Burst-of-Speed" winch circuitry increases line speed up to 60% over normal.

This high-capacity winch has increased efficiency and, therefore, requires less horsepower and generates less heat. For fine control, both brake and counter-balance valves are standard. New winch covers improve visibility of drum and cable. The winch is filled with 9/16" diameter rotation resistant cable. See the winch data chart on page nine for further information.



Anti-Two-Block

The 500B is equipped with a standard anti-two-block system. Two blocking occurs when the winch cable and attachments contact the underside of the boom sheave case, whether by winching up or extending the boom without paying out the winch cable. When this happens, the cable can be damaged by crimping or over-tensioning. The anti-two-block system prevents cable damage by sensing the position of the winch cable end attachments with respect to the sheave case and shutting down the functions that can cause two-blocking.

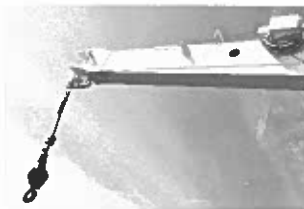

Single Axle Mounting

Our wide outriggers and stabilizers mean the National Series 500B can be mounted on many single-axle trucks. Yet, it still meets DOT and stability standards. The Series 500B crane, not the truck, is designed to take most of the stress. That adds up to lower investment and longer truck life.

Positive Planetary Turret Rotation

The planetary rotation gearbox with a hydraulic release brake allows the gearbox to backdrive whenever excessive side load is applied to the boom, reducing shock loads on the upper and lower crane structure and gearbox. The turret drive is designed with extra heavy bearings below the drive pinion. The gearbox and rotation bearing mounting surfaces are precision machined after welding. This ensures consistent tooth alignment for smooth rotation and low wear, even under maximum loads. The entire turret glides smoothly on a low inertia ball bearing race. Rotation is 375° non-continuous. The 500B is equipped with a turret rotation indicator to aid the operator in positioning loads.

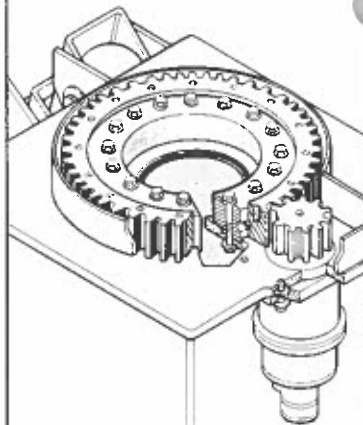

Dual Controls

Dual controls are standard on the Series 500B. The extra fine metering and low spool forces give you smoother, more precise control. Crane controls are identical on each side with SAE recommended orientation of functions. That means you always work the same control with the same hand. Dual stations provide more efficient operations and greater load visibility. Each station is equipped with kill and audible warning switches. A system pressure gauge is standard for easily checking pressures on all control functions. Foot throttles allow identical foot operation of engine speed from either side. Control rods are supported by nylon bearings, promoting smooth operation and reducing lubrication requirements.

Wide Stance

The Series 500B is equipped with National's field proven A-frame out-and-down outriggers for a consistently wide stance and efficient leveling on uneven ground. The outriggers retract

National's A-Frame "Out-and-Down" Stable Outriggers

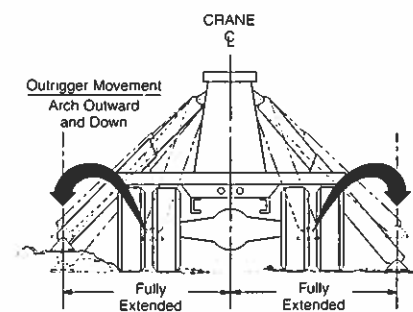

- Outriggers **equally** spaced from crane center line.
- Consistent outrigger span.
- No skidding the foot into position.



smoothly, without binding under load, first moving up, then in. Their efficient design and wider span — 18-foot (5.49m) — gives you solid stability. With less truck weight, you can carry larger payloads more economically. A precision-mounted level indicator aids the operator in leveling the unit during the set-up procedure.

Compact Design

The National Series 500B is built tough, but compact, so it fits in just 46½ inches (1,163mm) of bed space. That leaves ample payload space, making your Series 500B even more versatile. The operator platforms are made with open-mesh expanded metal to keep dirt and mud buildup to a minimum.

Easy Service, Low Downtime

We designed the new Series 500B with boom access holes for serviceability. The Series 500B frame allows easy access to control valves and plumbing for minor adjustments and fitting tightening. The complete console is easily removable for major repair. Access holes in boom sections allow viewing of extension system. The simplicity of boom design permits fast disassembly.

Warranty, Parts and Service

The National Warranty

National's warranty covers your crane against defects in materials or workmanship for **six full months** from the date of shipment, subject to the conditions of the warranty.

When you select a National crane, you're getting more than just a crane. You're getting a nationwide dealer warranty service network, strong warranty protection and our special concern for every product we make.

Read our warranty. Then, don't settle for less. For complete information, write National Warranty Service, Waverly, NE 68462.

The National Parts System

Authorized National Crane dealers maintain a parts supply to support the National cranes in each dealer's area. If a dealer cannot immediately supply a needed part, the factory maintains a back-up parts supply that provides 24-hour parts shipping in 90% of all breakdown rush orders. National's responsiveness to dealer requests means that your crane will be back on the job fast. National maintains a highly trained Service and Parts staff to answer dealer service questions and expedite parts shipping.

The National Service Center

National maintains a well-equipped service center where we do all our factory crane mounting. The central location of our Service Center makes it easy to return cranes for special modifications or extreme repairs. Most National dealers can perform all but the most unusual modifications or most serious repairs.

Should you need to return your crane to us for modification, warranty repair or other service, we will give it priority care and see it's returned as soon as possible.

National Series 500B Booms and Jibs

Boom and Jib Combinations

538B: 15'8" to 38' three section	
538B: 15'8" to 38' three section	5FJ15: 15' straight
538B: 15'8" to 38' three section	5FJ23M: 15' to 23' manual pull-out
547B: 18'8" to 47' three section	
547B: 18'8" to 47' three section	5FJ18: 18' straight
547B: 18'8" to 47' three section	5FJ29M: 18' to 29' manual pull-out
556B: 21'8" to 56' three section	
556B: 21'8" to 56' three section	5FJ21: 21' straight
556B: 21'8" to 56' three section	5FJ35M: 21' to 35' manual pull-out
566B: 26' to 66' three section	
566B: 26' to 66' three section	5FJ25: 25' straight
566B: 26' to 66' three section	5FJ42: 25' to 42' manual pull-out

The capacities shown will be reduced when accessories are attached to the boom or loadline.

Heights to 118 feet (36m) available

The National Series 500B is available with a choice of booms and jibs. One of these combinations is right for your 12½-ton capacity lifting requirements. Select the telescoping boom you want, then add one of National's jib options as a cost-efficient way to increase the reach and versatility of your Series 500B.

Do not operate cranes or accessories within 10 feet (3m) of live power lines.

1. Load ratings shown on these charts are maximum allowable loads with the outriggers properly extended on a firm, level surface and the crane leveled and mounted on a factory-recommended truck.

2. Always level the crane with the level indicator located on the crane frame.
3. The operator must reduce loads to allow for factors such as wind, ground conditions, operating speeds and the effect of freely suspended loads.
4. Overloading this crane may cause structural collapse or instability.

5. Weights of any accessories attached to the boom or loadline must be deducted from the load chart capacities.
6. Do not exceed jib capacities at any reduced boom lengths.

556B Capacity*

(Metric equivalents shown in parentheses)

Radius	All Booms Retracted	Second Section Extended	Third Section Extended
Maximum Capacity	25,000 lbs. (11,340kg.)		
8' (2.4m)	18,300 lbs. (8,300kg.)	15,200 lbs. (6,894kg.)	
12' (3.7m)	12,500 lbs. (5,670kg.)	10,800 lbs. (4,898kg.)	9,400 lbs. (4,263kg.)
16' (4.9m)	9,200 lbs. (4,173kg.)	8,150 lbs. (3,696kg.)	7,250 lbs. (3,288kg.)
20' (6.1m)	6,800 lbs. (3,084kg.)	6,650 lbs. (3,016kg.)	5,950 lbs. (2,698kg.)
24' (7.3m)		5,500 lbs. (2,494kg.)	4,950 lbs. (2,245kg.)
28' (8.5m)		4,650 lbs. (2,109kg.)	4,200 lbs. (1,905kg.)
32' (9.8m)		3,900 lbs. (1,769kg.)	3,600 lbs. (1,632kg.)
36' (11.0m)		3,150 lbs. (1,428kg.)	3,150 lbs. (1,428kg.)
40' (12.2m)			2,750 lbs. (1,247kg.)
44' (13.4m)			2,400 lbs. (1,088kg.)
48' (14.6m)			2,050 lbs. (929kg.)
52' (15.9m)			1,700 lbs. (771kg.)

*Capacities shown are for the 556B with the load suspended. Radius shown includes increase due to boom deflection. Capacities vary for cranes equipped with jibs or attachments. Consult factory for specific load rating information.

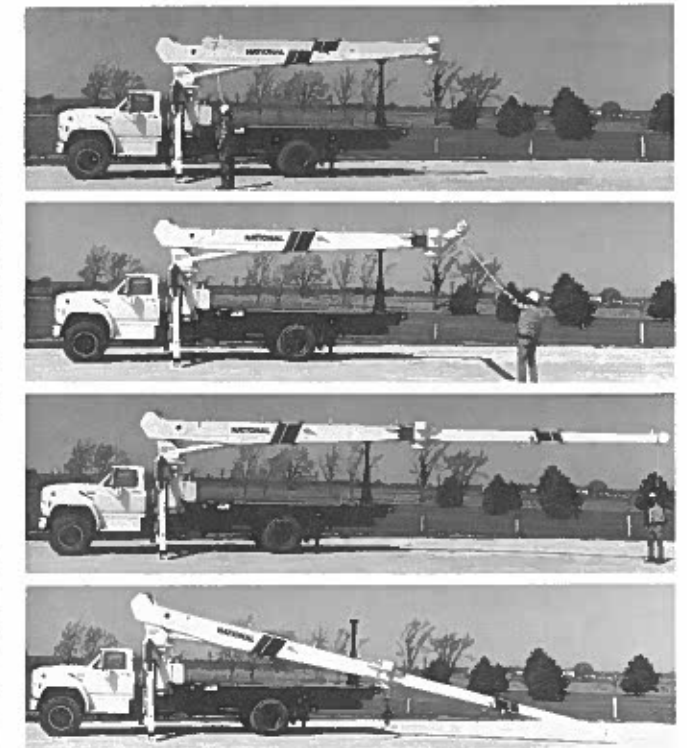

The sequence of photos above shows how a National jib folds out into working position.

National Series 500B Winch Data

CAUTION:

Do not deadhead lineblock against boom tip when extending boom.
Keep at least three wraps of loadline on drum at all times.
Use only the specified cable on this machine.

Winch	Cable Supplied	Average Breaking Strength	1 Part Line	2 Part Line	3 Part Line	4 Part Line
			Lift and Speed	Lift and Speed	Lift and Speed	Lift and Speed
Standard Planetary Winch	Standard 9/16" diameter rotation resistant	35,000 lbs.	Data applies to all 500B booms			
	Optional 9/16" diameter 6 x 25 IWRC	29,750 lbs.	*Applicable to the 500B boom. †Applicable to all other Series 500B booms. Speeds shown are the same for all Series 500B booms.			
With Optional Burst-of-Speed Feature	Same as corresponding cable data shown above.		3,000 lbs. 240 fpm	6,000 lbs. 120 fpm	9,000 lbs. 80 fpm	12,000 lbs. 60 fpm

All winch pulls and speeds are shown on the third layer (the fourth layer on 566B). Winch pulls would increase on the first and second layers. Winch line speeds would decrease on the first and second layers. Winch line pulls may be limited by the winch capacity or the cable safety factor. These are shown below:

Winch	Bare Drum Pull	Allowable Cable Pull
With standard rotation resistant rope	10,200 pounds	7,000 pounds
With optional 6 x 25 IWRC rope	10,200 pounds	8,400 pounds

**This feature is available with either the standard or optional cable. Ratings are based on intermittent use. High cycle applications may require optional oil cooler.

Note: Multiple part line block not included as standard equipment.

National Series 500B Load Rating Charts

The capacities shown below will be reduced when accessories are attached to the boom or loadline.

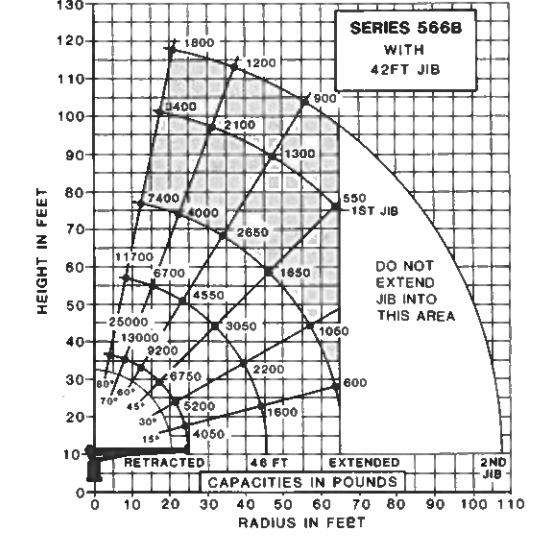
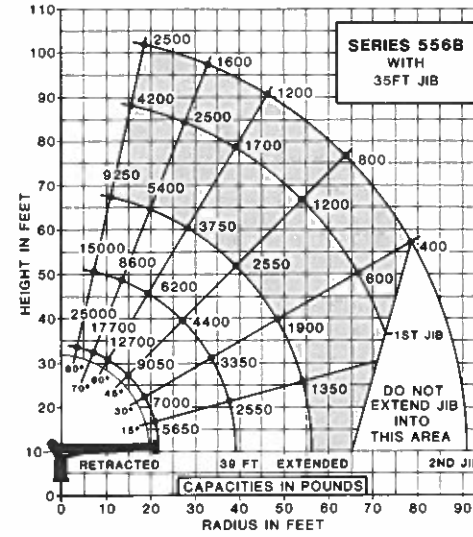
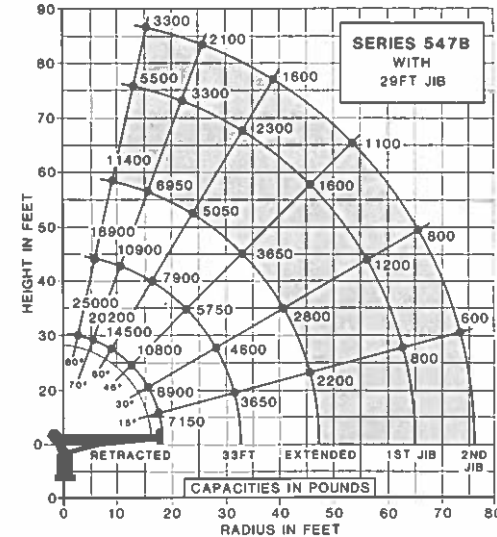
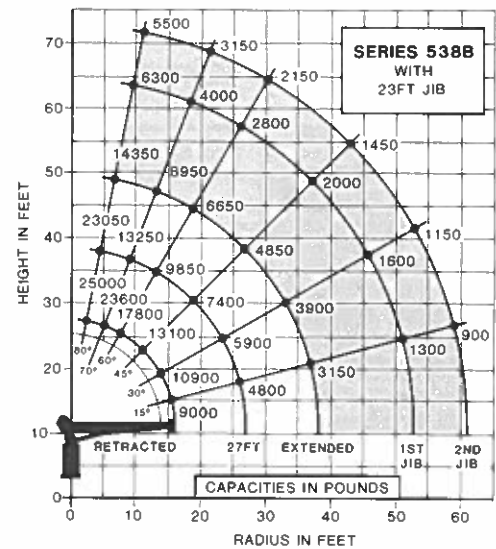
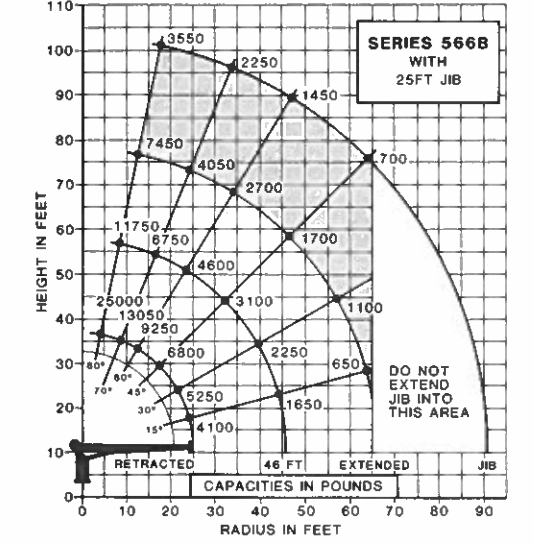
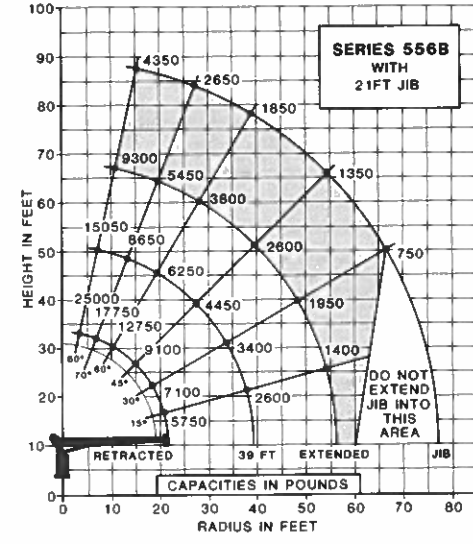
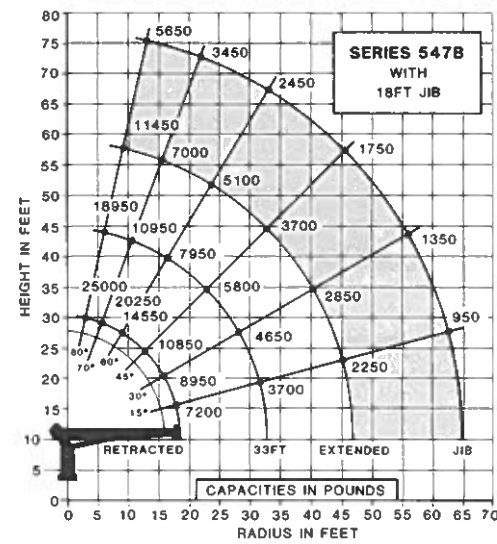
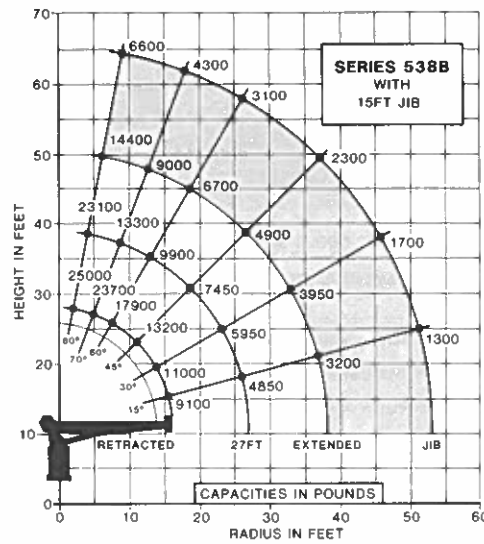
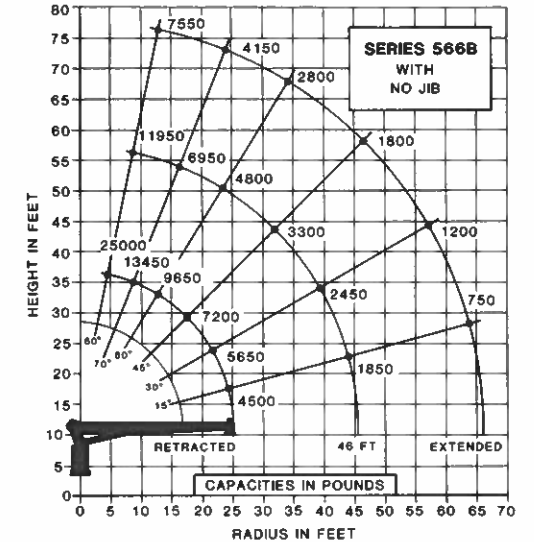
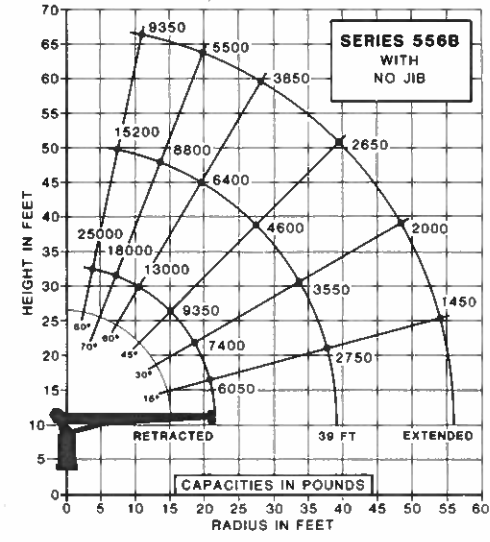
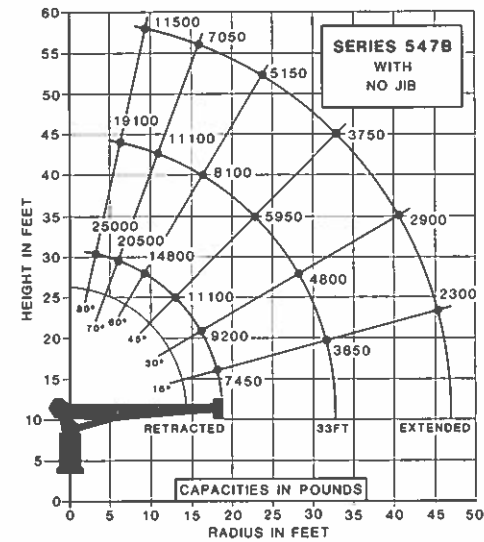
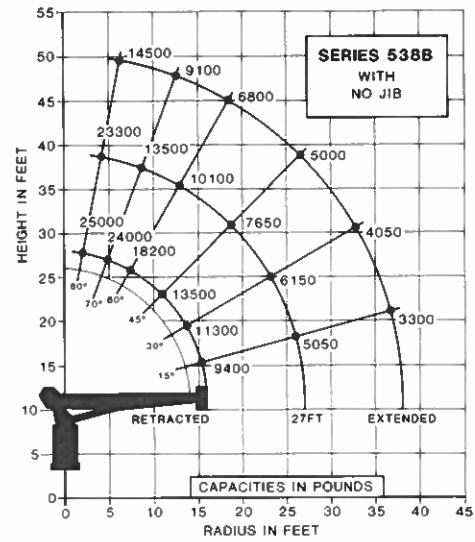

National Series 500B Truck Specifications

(Continued on next page)

Mounting Configurations The versatility of the Series 500B can be enhanced by the mounting configurations described at the right. The configurations are based on the 556B with an 85% stability factor. The complete unit must be installed in accordance with factory requirements and a test performed to determine actual stability and counterweight requirements since individual truck chassis vary.	Configuration 1 with Torsion Box This configuration allows the installation of the Series 500B on a chassis with a small frame by using the standard subbase. In most cases, the chassis will not require reinforcing and the amount of counterweight required is minimized, increasing payload capabilities. Requires standard subbase and RSH rear stabilizers. Full capacity work area is rear 180° of vehicle from outrigger to outrigger. (See Configuration 6 on following page for Series 566B.)	Configuration 2 without Torsion Box When a chassis has adequate frame strength this method allows installation without the use of the standard subbase. In some cases, if the truck is purchased above minimum specifications (such as with a diesel engine) and if the truck is equipped with a tandem axle, counterweight is not required. Requires RSH rear stabilizers and, usually, a bed with concrete counterweight centered near the crane. Some minimum trucks also require a heavy front bumper. Minimum single rear axle trucks will have little payload. (See Configuration 6 on following page for Series 566B.)	Configuration 3 with Torsion Box This mount requires a front stabilizer and additional counterweight in the underside of the bed for full capacity 360° around the truck. A front stabilizer gives the machine a solid base, helping the operator control crane loads. Requires front and rear stabilizers, standard subbase with counterweight centered in the bed between the crane and the rear stabilizers. Counterweighting in this manner reduces the load induced on the front stabilizer when lifting over the front of the truck. A front stabilizer for this configuration requires the following section modulus through the front suspension: ● 50,000 PSI-13.7 inch ³ ● 110,000 PSI-10.8 inch ³ Normally, a tapered front frame cannot be reinforced to these minimums. Please contact the factory. (See Configuration 6 on following page for Series 566B.)	Configuration 4 with Torsion Box The advantages of a rear mount Series 500B are: (1) allows the operator to effectively use the close-in working area to lift heavier loads; and (2) 360° solid stability at full rated load. A heavy-duty rear-mount subbase and hydraulic out-and-down outriggers are necessary to keep the total weight of the unit to a minimum with full stability. Requires 5HO outriggers behind cab, and a rear mount subbase. 205-inch minimum distance required between front and rear outriggers. Cab-over trucks may be used for rear mounted cranes but counterweight and a larger front axle weight rating may be required. (A rear mount configuration is not available for Series 566B.)	Configuration 5 with Torsion Box This mount allows 360° stability at full capacity without the use of a front stabilizer. It requires additional weight at the rear of the truck to reduce loading on the front axle when lifting over the front. Since the front tires are used as a stabilizing base, this mount is recommended only for the operator who occasionally lifts loads over the front of the vehicle. If loads are to be continually lifted around the front of the vehicle, a front stabilizer is recommended to give this mount a firm base. Requires rear stabilizers and standard subbase with counterweight in subbase or underside of bed. A front stabilizer for this configuration requires the following section modulus through the front suspension. ● 50,000 PSI-13.7 inch ³ ● 110,000 PSI-10.8 inch ³ Normally, a tapered front frame cannot be reinforced to these minimums. Please contact the factory. (See Configuration 6 on following page for Series 566B.)
Stable	180°	180°	360°	360°	360°
Gross Axle Weight Rating (GAWR), Front	10,860 lbs.	10,860 lbs.	10,860 lbs.	9,000 lbs.	10,860 lbs.
Gross Axle Weight Rating (GAWR), Rear	18,500 lbs.	18,500 lbs.	18,500 lbs.	34,000 lbs.	20,000 lbs.
Wheelbase (WB)	184 inches on Model 538B; 204 inches on Models 547B, 556B			222 inches	Same as Configuration 1, 2, and 3
Cab to axle/trunnion (CA/CT)	120 inches on Model 538B; 138 inches on Models 547B, 556B.*			144 inches	Same as Configuration 1, 2, and 3
Frame Section Modulus (SM) under crane					
50,000 PSI	13.7 inch ³	32.0 inch ³	13.7 inch ³	13.7 inch ³	13.7 inch ³
or					
110,000 PSI	10.8 inch ³	24.0 inch ³	10.8 inch ³	10.8 inch ³	10.8 inch ³
Frame Section Modulus (SM) over rear stabilizers					
50,000 PSI	13.7 inch ³	15.0 inch ³	13.7 inch ³	13.7 inch ³	13.7 inch ³
or					
110,000 PSI	10.8 inch ³	13.0 inch ³	10.8 inch ³	10.8 inch ³	10.8 inch ³
Stability Weight, Front**	5,500 lbs. minimum 6,500 lbs. maximum	6,000 lbs. minimum 6,500 lbs. maximum	5,200 lbs. minimum 6,200 lbs. maximum	6,000 lbs.	5,500 lbs. minimum 6,500 lbs. maximum
Stability Weight, Rear**	5,500 lbs. RSH	8,000 lbs. RSH	8,000 lbs. RSH	6,000 lbs.	9,000 lbs. RSH
Average Final Weight	25,000 lbs.	28,000 lbs.	27,500 lbs.	30,000 lbs.	28,500 lbs.
NOTES: (1) GAWR means Gross Axle Weight Rating and is dependent on all components of the vehicle, such as axles, tires, springs, frame, etc. meeting manufacturer's recommendations. Always specify GAWR when purchasing trucks. (2) Minimum axle requirements may increase with use of longer wheelbase, service bodies, diesel engines or front stabilizers. (3) Tandem axle trucks must be used for hauling larger payloads. (4) Diesel engines require variable speed governor and electric engine shut-off for smooth crane operation.	<p>*Longer CA required for 547B, 556B.</p>	<p>*Longer CA required for 547B, 556B.</p>	<p>*Longer CA required for 547B, 556B.</p>		<p>*Longer CA required for 547B, 556B.</p>
**Estimated axle scale weights prior to installation of crane and stabilizers and subbase if required for 85% stability.					

National Series 500B Truck Specifications (continued)

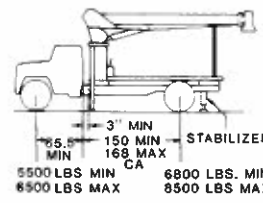
Mounting Configurations (Continued)	Configuration 6 (for 566B) with Torsion Box This configuration allows the installation of the Series 566B on a chassis with a small frame by using the standard subbase. In most cases, the chassis will not require reinforcing and the amount of counterweight required is minimized, increasing payload capabilities. Requires ASH rear stabilizers and subbase. Full capacity work area is rear 180° of vehicle from outrigger to outrigger. Truck frame must have or be capable of being reinforced to 10.8 inch ³ SM and 685,000 in. lb. RBM under the crane, spring hangar to spring hangar. It is easy to overload the truck axles when configuring this truck; consequently, careful consideration must be given to the effect of the weight of options, accessories, and payload on the truck axle loadings.
Stable	180°
Gross Axle Weight Rating (GAWR), Front	12,000 lbs.
Gross Axle Weight Rating (GAWR), Rear	20,000 lbs. (See note 6)
Wheelbase (WB)	216 inches
Cab to axle/trunnion (CA/CT)	150" minimum; 168" maximum
Frame Section Modulus (SM) under crane 50,000 PSI	13.7 inch ³
or 110,000 PSI	10.8 inch ³
Frame Section Modulus (SM) over rear stabilizers 50,000 PSI	13.7 inch ³
or 110,000 PSI	10.8 inch ³
Stability Weight, Front**	5,500 lbs. minimum 6,500 lbs. maximum
Stability Weight, Rear**	6,800 lbs. minimum ASH; 8,500 lbs. maximum ASH
Average Final Weight	29,500 lbs.
NOTES: (1) GAWR means Gross Axle Weight Rating and is dependent on all components of the vehicle, such as axles, tires, springs, frame, etc. meeting manufacturer's recommendations. Always specify GAWR when purchasing trucks. (2) Minimum axle requirements may increase with use of longer wheelbase, service bodies, diesel engines or front stabilizers. (3) Tandem axle trucks must be used for hauling larger payloads. (4) Diesel engines require variable speed governor and electric engine shut-off for smooth crane operation. (5) 566B requires 20,000 GAWRR and 32,000 GVWR. (6) Some states restrict single rear axle loads to 18,000 pounds.	 <p data-bbox="584 1884 1383 1925">**Estimated axle scale weights prior to installation of crane and stabilizers and subbase if required for 85% stability.</p>

National Series 500B Boom Rests

Cranes are tough when they're in use, but they can be severely damaged during travel from job to job. The only way a crane can be protected from this type of wear and damage is a strong, solid, boom rest.

Boom Rests

- Add years to the life of your crane
- Reduce stress on the crane frame
- Protect rotation gear from transit damage
- Remove stress from truck frame
- Spread crane load more evenly
- Reduce maintenance and down time

In addition, boom rests are required to provide a positive way to immobilize your crane for transit.

National Crane supplies four heavy-duty boom rests for strong, sure protection of your crane. There is a quality National boom rest to fit your mounting configuration. All National Cranes must be fitted with a boom rest. All factory mounted cranes will be supplied with a boom rest.
NOTE: Only shorter booms can be stowed forward.

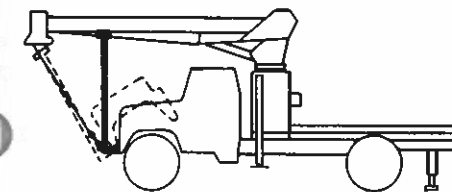

Front mount for trucks with lifting hoods.

Larger Front Axle Rating Required.

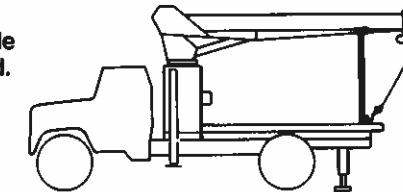

Horizontal rear bed mount for greater load space

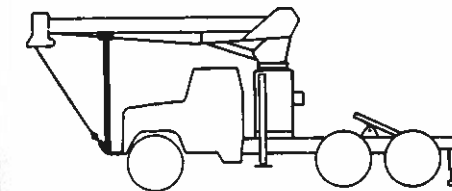

Tractor/trailer front mount

Larger Front Axle Rating Required.

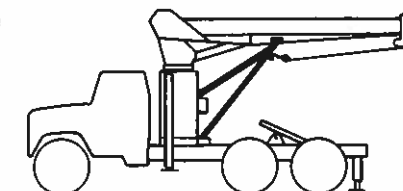

Tractor/trailer rear mount

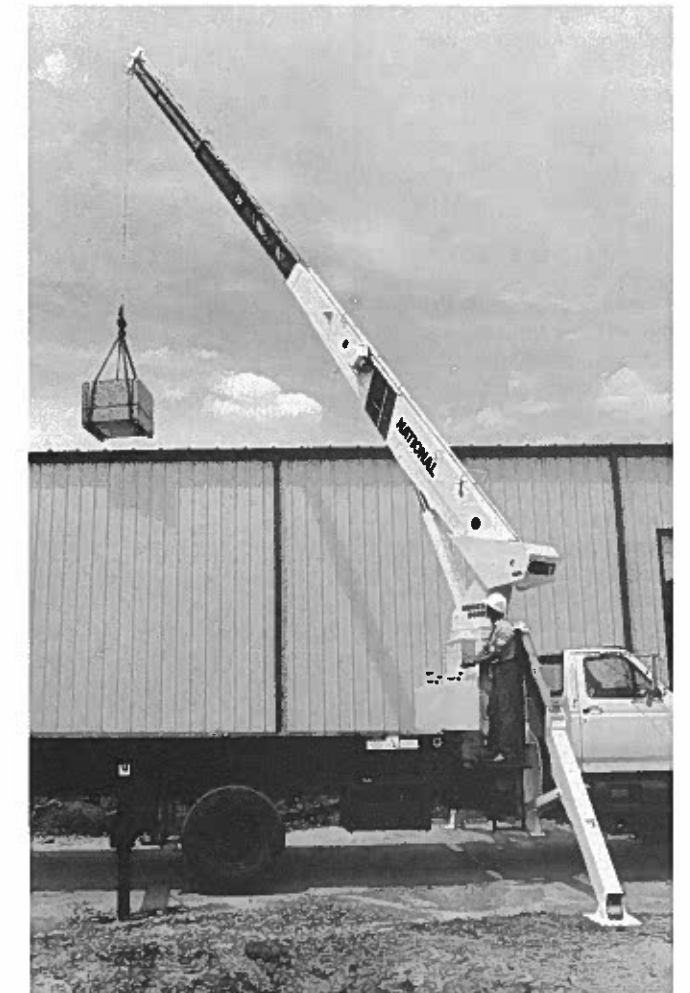

National Series 500B Accessories

Every Series 500B is part of the National Lifting System.

The National Lifting System can equip your 500B to do more than just lift or handle materials. It lets you equip your truck-mounted crane to perform the functions of a whole fleet of specialized vehicles, and at a fraction of the cost.

Because your 500B can do so many jobs from start to finish, you save time, money, and manpower on almost every job you do. You'll find you can do more, faster, with less equipment. And that's money in your pocket.

Get the most from your National 500B. Make it more than just a crane with cost-efficient, hard-working accessories from the National Lifting System.

Note:

Weights of all accessories attached to the boom or loadline of the crane must be deducted from the effective lifting capacity.

Consult your dealer for specific accessory availability. Some accessories cannot be used in combination with other accessories and/or certain boom/jib combinations.

"Burst-of-Speed" Planetary Winch Feature

Enjoy the advantage of faster, more efficient pay-out and pick-up of cable with National's optional "Burst-of-Speed" high performance planetary gear drive winch. This control feature increases line speed up to 60% over normal. It is designed for intermittent use and may require optional oil cooler for high cycle applications. See the winch data chart on page 9 for further information.

Model BOS

Remote Control

National offers one-hand remote control for your Series 500B. Ideal for use where precise control and total load visibility are required.

Fine metering and instant response mean operators can position loads or work platforms easily.

National's remote controls are built with solid state circuitry and few working parts. They are designed for reliability.

Available in two models: R4 with tilt, turn, telescope and winch functions, and R3 with tilt, turn, and telescope only. R3 should be used to control cranes from basket.

A priority control valve, operated by a trigger on the remote control unit, regulates oil flow and gives you fingertip speed control over all crane functions.

National's remote control is the lightweight, easy-to-use way to add extra versatility to your crane. Consult your dealer or the factory for availability.

Model R3

Tilt, turn and telescope

Model R4

Tilt, turn, telescope and winch



One Person Basket

Strong, lightweight fiberglass basket with 300-pound capacity puts personnel where you want them for tough maintenance and installation jobs. Optional dual basket bracket for two-basket operation on main boom. (Note: Jib will accommodate only one basket.) Easy on-off. Safety belts included. With basket(s) attached to the crane, the crane must not be operated at a position where the crane load chart shows less than the following capacities:

- One fiberglass basket — 550 pounds
- Two fiberglass baskets — 1,100 pounds

Model B1

Model B1-L

With lock

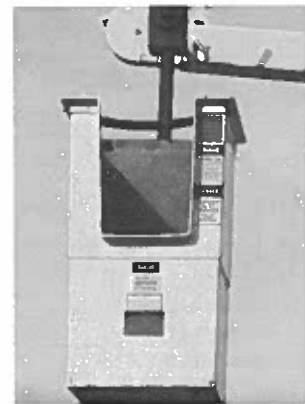

Three Pump System

This optional pump system provides three separate (or individual) hydraulic circuits for independent operation of winch, swing, and crane functions. The option increases productivity on high-cycle jobs and facilitates the ease of operation.

Hydraulic Oil Cooler

High duty cycle applications may require this option, which is designed to automatically cool the hydraulic oil.

Model HOC

Two Person Basket

Extra capacity steel basket, swing-mounted to self-level. An adjustable, over-center lever-operated friction brake for stability and locking. Safety belts included. The basket must not be used in load-rated areas where the crane load chart shows capacities less than 1,150 pounds. The maximum capacity of the basket is 500 pounds.

Model BS-1

5-ft. yoke



Caution

Do not operate crane booms, jib extensions, any accessories, or loads within 10 feet (3m) of live power lines or other electrified sources. Do not exceed jib capacities at any reduced boom lengths.

Stabilizers

We offer a complete range of front and rear stabilizers with hydraulic vertical and horizontal motion. All cylinders are fully enclosed for protection against dirt and on-the-job damage.

Stabilizers

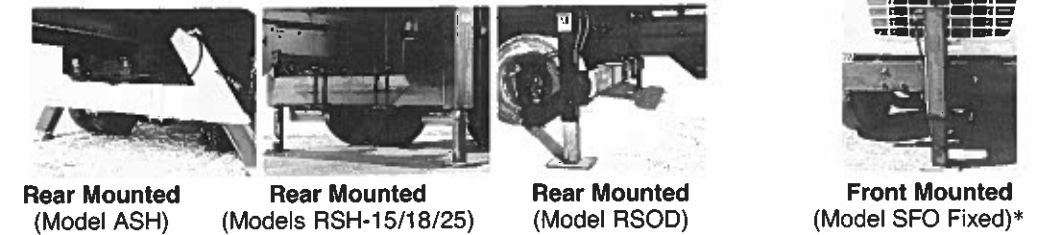

Vertical Travel	20"	15", 18" or 25"	25.5"	25"
Ground Penetration (38" Frame Height)	8"	3", 6" or 13"	10"	13"
Operation	All-Hydraulic	All-Hydraulic	All-Hydraulic	All-Hydraulic
Span	10'	6' (RSH-15) 8' (RSH-18/25)	14'	
Controls	All stabilizers noted above can be operated from either crane control station			

*The SFO, a single front mounted hydraulic stabilizer, is not designed to lift the vehicle, but will provide stability for the vehicle after it has been leveled. The SFO has a 25" vertical stroke.

Pallet Fork

Turns your Series 500B into a versatile, payload-packing fork lift. Great for delivering palletted material right where you want it. 4,400 lbs. (1,996kg) capacity with adjustable throat and teeth. Handles most loads with ease.

Capacity:	4,400 lbs. at 20" center
Throat Opening: (adjustable)	41" to 65"
Tooth Length:	38"
Tooth Width: (outside to outside)	33.5" to 57" min. max.
Weight:	350 lbs.

Model MKF

(Manual leveling, adjustable throat)

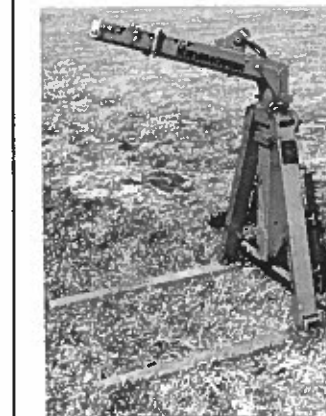

Cross-Frane Outriggers

Extended Span	15'6"
Retracted Span	7'11"
Vertical Travel	
Over-Frame	25"
Under-Frame	18"
Ground Penetration (38" Frame Height)	10"
Mounting Space	
Crane/Outrigger	60"
Outrigger Only	24"
Mounting	Behind cab at rear of chassis or both

Model 5HO

Capacity Alert System

National offers two capacity alert options. The audible-visual capacity alert system is designed to alert the operator when he reaches a maximum capacity condition on the crane structure. This system activates the truck horn when the capacity load is exceeded on the main boom.

The hydraulic capacity alert system is a hydraulically operated, maximum capacity sensing device that is designed to stop all of the normal crane functions that cause overload when maximum capacity is exceeded on the main boom. Neither of these system is applicable to jib and stability capacities.

Model AAS

(Audible capacity alert system)

Model HAS

(Hydraulic capacity alert system)

Loose Material Clam Bucket

Increase the flexibility of your National crane with a National clam bucket. Use this versatile accessory to load or move up to 2/3 cubic yard of loose materials with each bite. Hooks easily to loadline, comes with 50 feet of hydraulic hose on automatic reel and quick-connect fittings. Extension hoses are required for use with jibs. Just position the load where you want it and open the bucket.

Model LMC

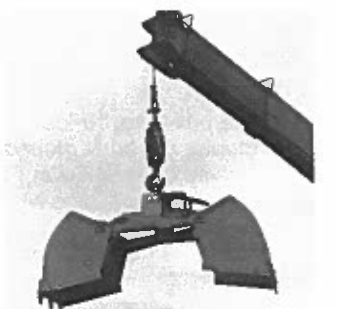

National Series 500B Specifications

General Construction

Low-alloy, high-strength steel, including T-1, Ex-Ten, Stressproof and Hi-Yield and other steels combined with special, low-hydrogen welding techniques wherever advantageous. Standard color: painted *National Ivory*.

Frame:

Box construction bolt-on truck frame mounting brackets and bolt-on subbase attachment. Rotation bearing, gearbox, and level indicator mounting surfaces are precision machined after welding to ensure accurate alignment and flat surfaces for prolonged life.

Turret:

Fabricated, rigid structure, well-braced for stability. The bearing surface is machined and the pin holes are bored after welding to ensure accurate alignment and flat surfaces for prolonged life.

Rotation:

375° noncontinuous. Rotational force 224,000 in./lbs. (670,000 in./lbs. breaking strength). Turret rotation is by hydraulic orbit motor and planetary gearbox driving a pinion. The turret rotates on a ball-bearing race. Spring-applied-hydraulic release brake provides positive, no-drift lateral positioning.

Outriggers:

"A" frame box-type, 18-foot span (center of pad at ground level) moves out-and-down, will not bind when raising or lowering truck. Can be positioned to 8 inches below ground level when mounted on truck with a frame height of 38 inches. Outrigger cylinders are equipped with butt-mounted, safety check valves.

Lift:

Double-acting hydraulic cylinder raises and lowers the boom; butt-mounted, safety holding valve prevents the boom from falling in the event

of hose failure. Tough, field-tested bearings in lift cylinder and boom pivot combined with micro-honed pins provide long life with reduced maintenance.

Boom:

Boxed construction. Telescopes hydraulically proportionally on nylon plates impregnated with molybdenum disulfide on all sides of boom, permitting maximum loads to be extended at greater radii. Holding valve prevents retraction except under power.

Controls:

Dual side, stand-up, with operator platform and foot accelerator identical on both sides. Simultaneous operation of load-line and other operations standard. Horn and stop switch on both sides. Controls easily removable for maintenance.

Winch:

Hydraulic gear motor with planetary gear reduction brake, and counterbalance valve for "power down" load lowering. 10,200-pound bare drum, single line pull available with 220 feet of 9/16" diameter, 35,000-pound* breaking strength on the standard rotation resistant loadline. Optional 9/16" diameter, 29,750-pound* breaking strength 6/25 IWRC loadline is available. Optional "Burst-of-Speed" control increases pay-out and pick-up of unloaded cable 60% over normal operating speed with maximum rated single line pull of 3,000 pounds.

*Because of ANSI safety factor requirements, the standard rotation resistant wire rope is rated at a 7,000-pound, 5:1, single line pull and the optional 6x25 IWRC wire rope is rated at an 8,400-pound, 3.5:1, single line pull.

Pump:

One Vickers, high-pressure, high-speed, balanced-vane, replaceable cartridge-type tandem pump independently providing 35 gpm to winch, and 23 gpm to crane for smooth, fast, simultaneous operation.

Cylinders:

Shaft packing: Polyurethane U-cup type. Shafts: Hi-Yield, stress-relieved, chrome-plated. Piston sets: Polyurethane U-cup and rider construction. Cylinder barrels: Micro-honed tubing, butt-mounted, safety check valves.

Valves:

Four-way, spring-centered, spool type with independent relief valves set at 2,350 psi (maximum 3,050 psi on winch system) to protect circuits against overload.

Hose:

All high-pressure hose is wire-braid reinforced, having a minimum safety factor of 4 to 1.

Operating Speeds:

Winch third layer speed: 150 fpm. Rotation 375°, 40-45 seconds. Boom up, -10° to 80°, 16 seconds. Boom down, 80° to -10°, 12 seconds. Boom extend: 56 fpm. Boom retract: 52 fpm. When using remote control, crane function speeds will be reduced by 50% to assure smooth operation. (Speeds above assume no load with 23 gpm oil flow on boom and 34 gpm on winch.)

Oil Tank Capacities:

60-gallon supply tank. Normally mounted on subframe. Sight gauge, breather, suction strainer, clean-out, and magnetic plug.

Filter:

10-micron, replaceable-cartridge, return-line filter. 100% filtration.

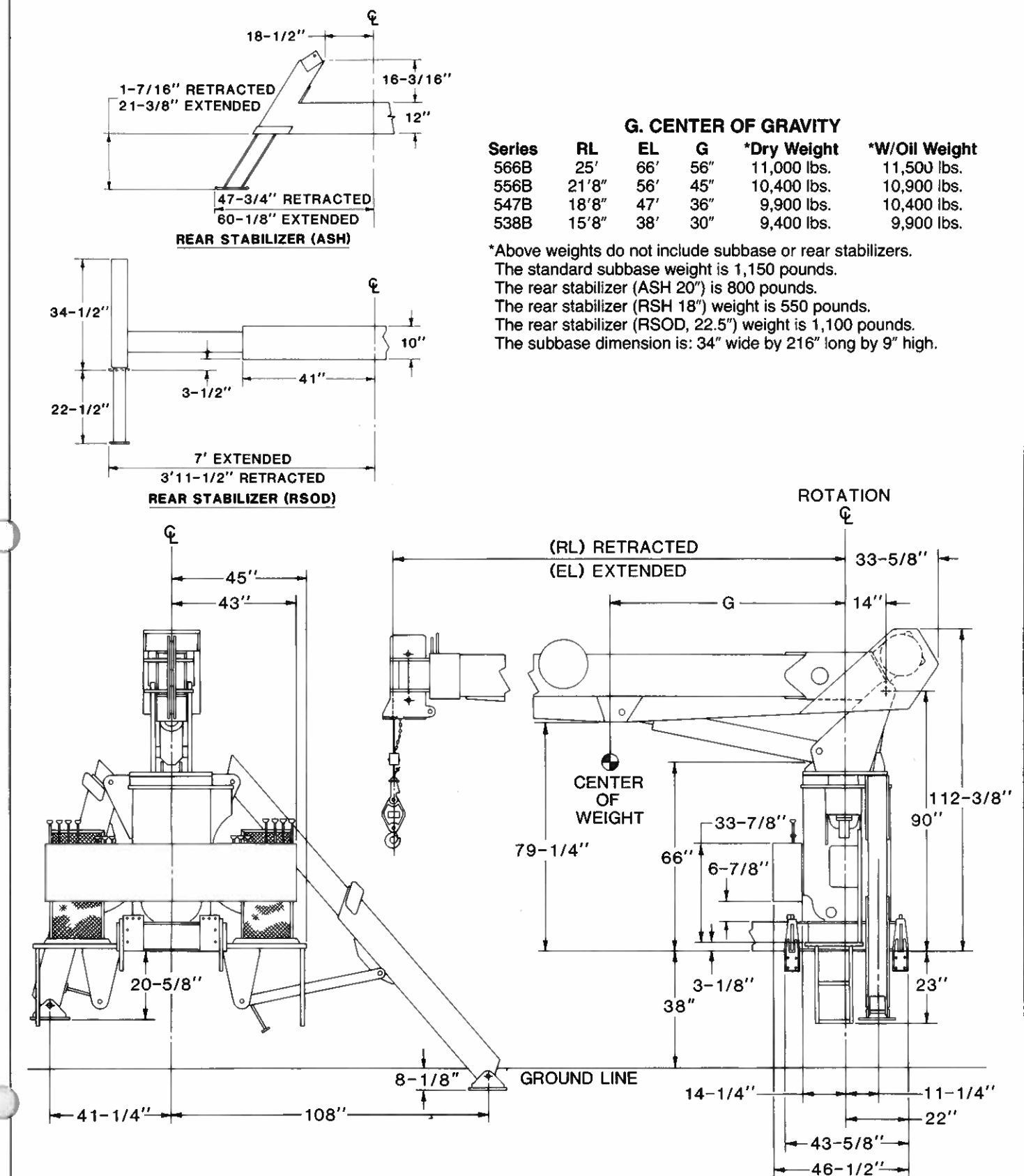
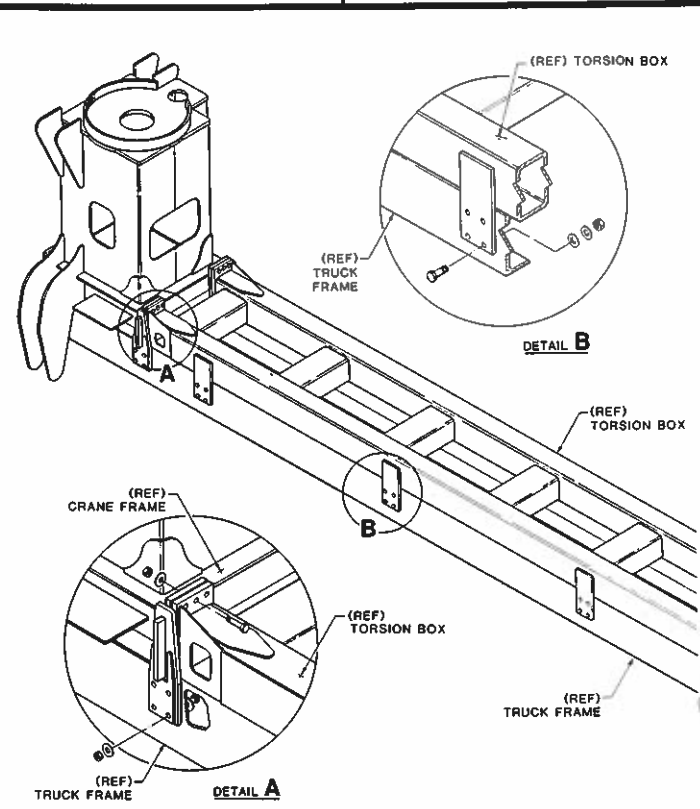

Series	G. CENTER OF GRAVITY				
	RL	EL	G	*Dry Weight	*W/Oil Weight
566B	25'	66'	56"	11,000 lbs.	11,500 lbs.
556B	21'8"	56'	45"	10,400 lbs.	10,900 lbs.
547B	18'8"	47'	36"	9,900 lbs.	10,400 lbs.
538B	15'8"	38'	30"	9,400 lbs.	9,900 lbs.

*Above weights do not include subbase or rear stabilizers. The standard subbase weight is 1,150 pounds. The rear stabilizer (ASH 20") is 800 pounds. The rear stabilizer (RSH 18") weight is 550 pounds. The rear stabilizer (RSOD, 22.5") weight is 1,100 pounds. The subbase dimension is: 34" wide by 216" long by 9" high.

National Series 500B Proposal

	Description	Price
Date: _____	1. Series _____	\$ _____
Prepared for: _____	2. Boom _____	_____
_____	3. Jib _____	_____
_____	4. Rear Stabilizers <input type="checkbox"/> ASH <input type="checkbox"/> RSH 18" <input type="checkbox"/> RSOD	_____
Submitted by: _____	5. Front Stabilizer <input type="checkbox"/> SFO	_____
_____	6. Line Block <input type="checkbox"/> 2 Part <input type="checkbox"/> 3 Part <input type="checkbox"/> 4 Part	_____
(Firm Name)	Accessories	
_____	7. "Burst-of-Speed" Planetary Winch Feature	_____
_____	8. _____	_____
(Address)	9. _____	_____
_____	Mounting	
(City & State)	10. Installation: Behind Cab	_____
_____	(Deduct if no torsion box required)	(_____)
(Zip)	11. Installation: Rear Mounting (add to installation charge above)	_____
_____	<input type="checkbox"/> Air Throttle	_____
(Phone)	<input type="checkbox"/> Rear Mounting Hydraulic Group	_____
Signed: _____	<input type="checkbox"/> Heavy-duty Torsion Box	_____
_____	<input type="checkbox"/> Reserve Frame Conversion Kit	_____
	<input type="checkbox"/> HO Outriggers	_____
	12. Frame Reinforcement: <input type="checkbox"/> Weld <input type="checkbox"/> Bolt-Extra	_____
	13. Platform Body _____ft. <input type="checkbox"/> Wood <input type="checkbox"/> Steel	_____
	14. Weight in bed _____lbs. (if required)	_____
	15. Boom rest: <input type="checkbox"/> Parallel <input type="checkbox"/> Other	_____
	16. Mount Stabilizers (Rear) _____	_____
	17. Mount Stabilizers (Front) _____	_____
	18. Chassis _____	_____
	19. Rear Bumper Underride Protection <input type="checkbox"/> Ordered <input type="checkbox"/> Not Ordered _____	_____
	20. Freight _____	_____
	This quotation will remain firm for _____ days.	
	Accepted by: _____	\$ _____
	(Name)	TOTAL PRICE
	_____	_____
	(Firm Name)	(Date)

National reserves the right to change designs, prices, and specifications at any time without notice.

Your National Dealer



General Offices: 11200 North 148th Street/Waverly, NE 68462
Phone: 402/786-6300; Telex: 438061; Fax: 402/786-6363