

Krupp Hydraulic All-Terrain Crane
140 GMT-AT
165 ton Capacity



Superstructure Specifications

Boom

48 ft – 152 ft 4-section boom,
1 base + 3 power sections
(with remote lock-out system)

Telescoping cycle:

1. section 90 sec.
2. section 80 sec.
3. section 52 sec.

High speed:

1. section 50 sec.
2. section 44 sec.
3. section 30 sec.

*) Jibs

41/66 ft 2 stage swing-away
lattice extension

38 – 118 ft lattice extension + inserts
(for straight or off-set use)

46 – 126,6 ft power luffing jib

Main Hoist

Axial piston motor with planetary gear
and fail-safe brake

Single line pull max.: 22.050 lbs

Single line speed max.: 525 ft/min

Drum diameter: 22"

Rope diameter: 1"

Rope length: 985 ft

*) Auxiliary Hoist

Data identical with main hoist

Hook Blocks

90 ton

*) 155, 35 ton

Boom Elevation

Hydraulic cylinder with integral
holding valve, boom angle

from -1.2 to +82.2 degrees

Elevation cycle: 120 sec.

High speed: 65 sec.

Swing Gear

Axial piston motor with planetary
gear, holding and service brake,

2 swing speeds,

each 0 – 1,6 rpm variable

Engine

6 cyl. Daimler Benz OM 366 LA,
water-cooled, 195 hp at 2300 rpm

Tank capacity: 105-gal. diesel

Hydraulic system

3 separate circuits: 2 axial piston
pumps with integrated infinitely
variable speed and load control,
1 3-section axial piston pump. Oil cooler.

Tank capacity: 400 gal. hydraulic oil

Control system

Infinite variation of all crane motions by
hydraulic pilot circuit, dead-man
position

Counterweight

46.300 lbs, in 6 sections, hydraulically
removable

Operator's cab

Full vision, aluminium, safety glass, fully
adjustable operator's seat with

hydraulic suspension, diesel engine
coolant heaters and ventilation system,
optional stationary heaters, complete
engine instrumentation and crane
operating controls

Safety installations

Hoist limit switch, lock valves, pressure
relief valves. Hoist drum rotation
indicator

*) Electronic load moment safety device
with automatic cut-out and indicators
for load moment and working radius,
lowering limit switch

*) Optional items

Carrier Specifications

Chassis

Krupp heavy-duty 6-axle carrier welded
box-type frame from high-tensile steel

Engine

12 cyl. Daimler Benz OM 424,
water-cooled, 420 hp at 2300 rpm
Tank capacity: 210 gal.

Transmission

Allison 5-speed automatic gear-box
transfer case, 2 speed with
differential lock

Axles

- | | |
|------------------|---------------|
| 1. steering axle | 4. rigid axle |
| 2. driven | 5. driven |
| steering axle | steering axle |
| 3. steering axle | 6. driven |
| | steering axle |

driven axles = planetary axles
transverse differential lock on all
drive axles

5. axle with interaxle differential
lock

Suspension

1. – 6. axle hydropneumatic suspension
system and axle lock-outs

2 way automatic suspension range, i.e.
+6"/-6" and +4"/-8"

Tyres

12 tyres 16.0 – 25

*) 20.5 – 25

Steering

ZF dual-circuit hydraulic
power steering

Brakes

Service brake:
pneumatic dual-circuit acting on all
wheels

Permanent brake:
retarder of Allison automatic
transmission

Auxiliary brake:
pneumatically operated spring-loaded
brake, acting on 2nd to 6th axle

Driver's cab

Aluminium, three-man-design with bunk,
safety glass, adjustable hydraulically
suspended seats, diesel engine coolant
heaters and ventilation system, optional
stationary heaters, and driving controls

Outriggers

Independent horizontal and vertical
hydraulic motion of each beam.

Control on each side of chassis.

Sight level device.

Electrical equipment

Three-phase alternator 28 V/55 A
2 batteries 12 V/170 Ah

Performance

Travelling speeds: max. 45 mph
min. 0.1 mph

Gradeability: 48%

Turning radius: 46 ft

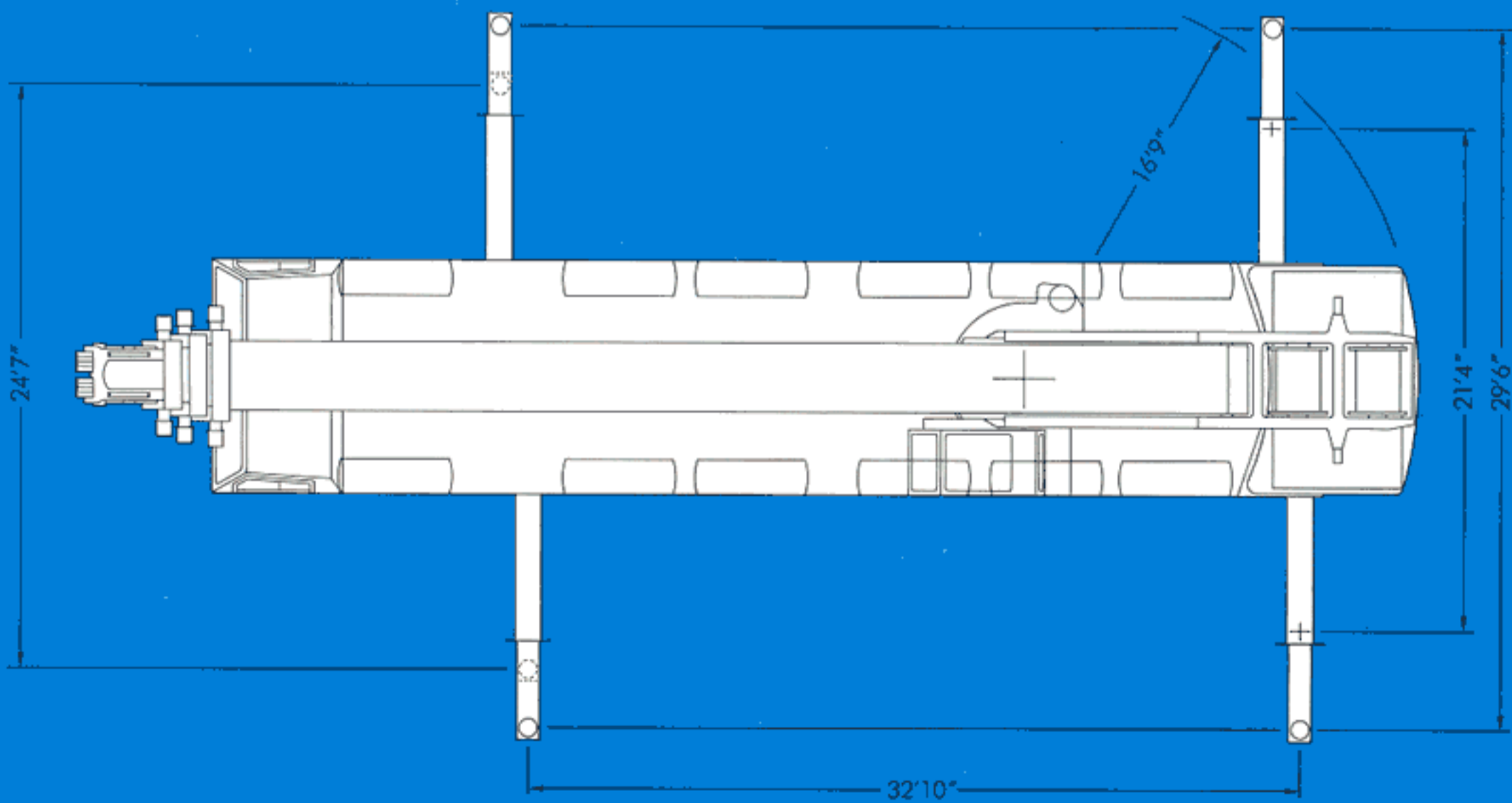
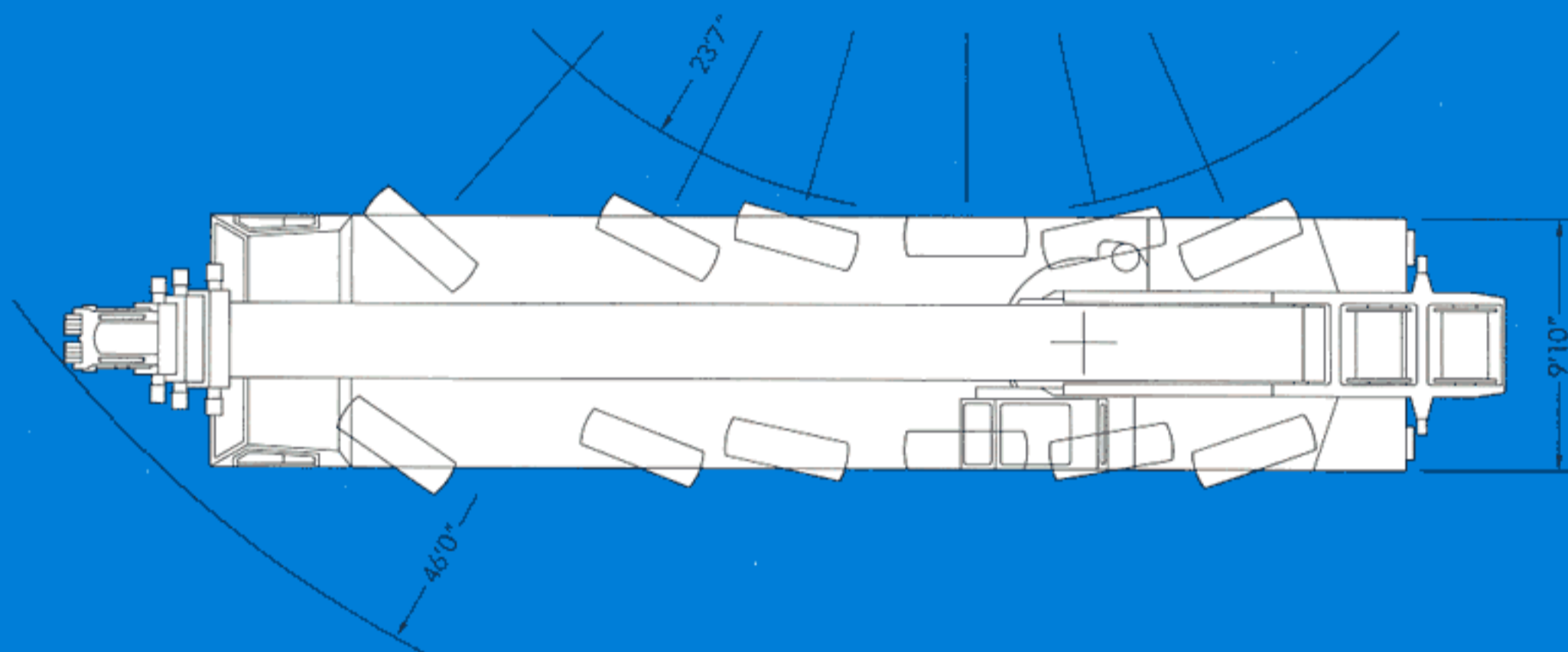
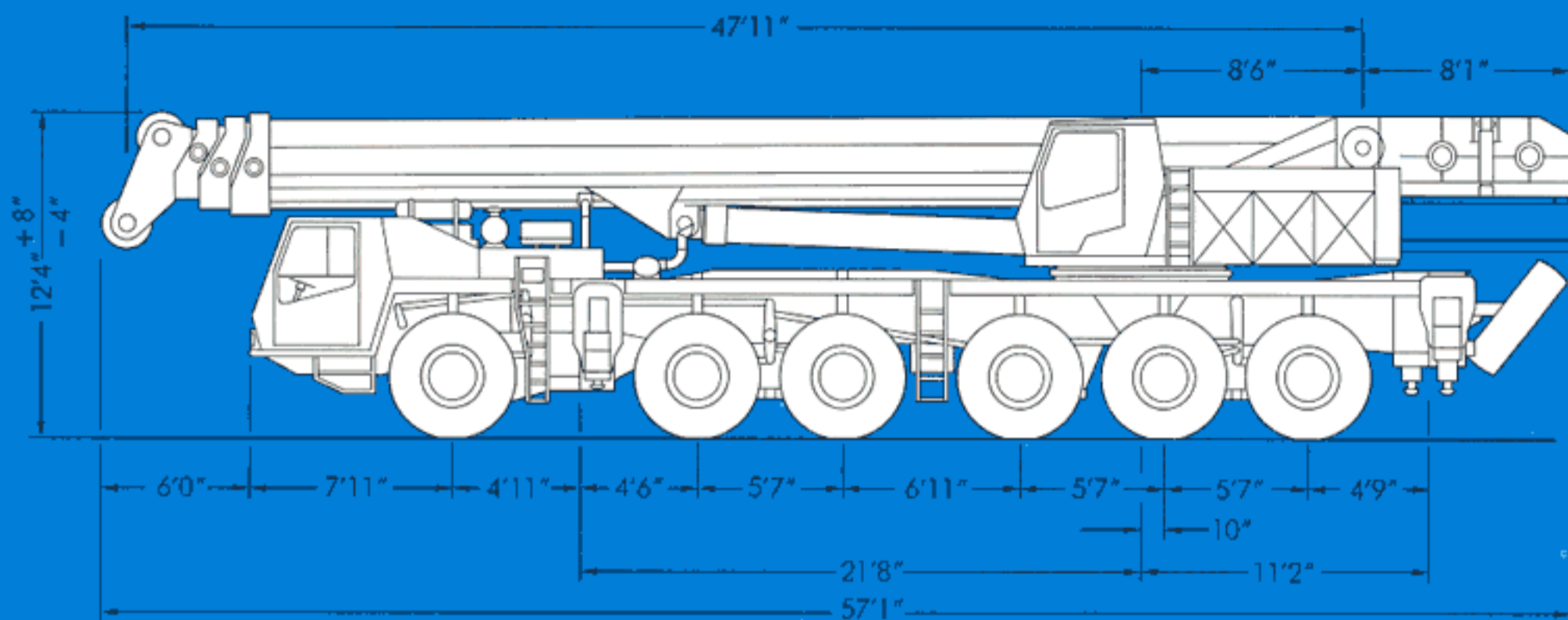

Lifting capacities in 1000 lbs on outriggers

360° Main boom

Counterweight 46.300 lbs

Radius (ft)	Boom length (ft)						
	48'0"			83'0"		117'0"	152'0"
10	330.0	284.4	227.6	185.1	185.1	94.8	
15	250.9	224.2	181.8	184.5	175.4	94.8	
20	186.7	182.7	150.4	167.6	146.9	94.8	43.0
25	128.0	144.8	126.9	139.9	123.4	91.7	43.0
30	88.1	109.5	108.8	106.3	106.1	83.5	43.0
35	67.0	81.7	91.6	79.7	89.3	76.4	43.0
40				60.6	70.6	69.2	43.0
45				48.3	57.5	60.3	43.0
50				39.6	46.6	50.8	41.8
55				32.6	38.7	42.5	39.9
60						26.5	33.4
65				21.3	28.2	30.6	34.3
70				17.6	23.7	26.8	30.4
75						23.3	26.8
80						20.0	23.5
85						17.3	20.6
90						14.8	18.1
95						12.6	16.0
100						10.7	14.1
105						9.0	12.3
110							10.8
115							9.5
120							8.3
125							6.9
130							5.9
135	B 1	B		B			4.9

Notes for lifting capacities

Rated loads do not exceed 85 % of tipping load with the machine properly levelled on firm ground.

360° duties – on outriggers fully extended, other than noted above.

Note counterweight required as listed in relevant lifting capacity columns.

For safe crane operation due allowance must be made to compensate for high winds, side load, pendulum action and other hazardous conditions. No side pull permitted.

Hook blocks, slings and/or boom attachments are considered part of the load, and

their weight must be deducted from the rated lifting capacity to determine the net load.

Lifting capacities are based on boom sections locked by remote control.

Consult crane manual to determine weight reduction for load handling devices and boom attachments.

Operate crane strictly in compliance with operator's manual.

B: Outrigger base 24'7"
 B 1: Outrigger base 24'7"/21'4"
 *: Section 2 extended
 *): Section 2 and 3 extended

Load capacities above bold line are based on structural strength and tipping must not be relied upon as a limitation of lifting capacity. Rated loads must not be exceeded.

**360° Main boom
with 41/66 ft 2-stage
swing-away lattice extension**
Counterweight 39.680 lbs

Radius (ft)	Boom length (ft)									
	48	48	83	83	117	152	114 + 41	146 + 41	146 + 66	
10	282.3	227.6	185.1	185.1	94.8					
15	224.0	181.2	184.5	175.4	94.8					
20	182.5	149.2	167.6	146.0	94.8	43.0	26.4			
25	140.5	126.9	137.0	123.8	91.7	43.0	26.4			
30	103.1	108.8	98.6	105.3	83.5	43.0	26.4	20.9		
35	76.6	88.0	73.7	85.6	76.1	43.0	26.0	20.9	13.6	
40			55.8	66.3	67.8	43.0	25.1	20.9	13.6	
45			44.2	53.7	56.9	43.0	23.4	20.9	13.6	
50			35.8	44.2	47.5	42.0	21.9	20.9	13.6	
55			29.1	36.7	39.7	40.1	20.4	20.6	13.6	
60			23.6	30.7	33.8	37.0	19.2	19.9	13.6	
65			19.0	25.7	29.6	32.1	18.2	19.9	13.6	
70			15.4	21.6	25.1	28.1	17.0	18.0	13.6	
75					21.3	24.6	15.9	17.1	13.4	
80					18.2	21.5	15.0	16.3	13.1	
85					15.3	18.9	14.3	15.6	12.6	
90					13.1	16.5	13.7	15.0	12.0	
95					11.1	14.4	12.9	14.4	11.5	
100					9.3	12.7	12.1	13.6	11.1	
105					7.7	11.0	11.4	12.1	10.8	
110							9.5	10.9	10.7	10.2
115							8.1	10.4	9.4	9.9
120							6.8	9.9	8.2	9.3
125							5.6	9.4	7.1	8.3
130							4.8	8.9	6.0	7.3
135								8.1	5.0	6.2
140	B		B							5.3

Counterweight 22.050 lbs

Radius (ft)	Boom length (ft)											
	48	48	48	83	83	82*	117	117*)	152	114 + 41	146 + 41	146 + 66
10	323.4	280.0	227.6	185.1	185.1	138.9	94.8	61.7				
15	236.2	220.4	181.8	184.5	174.8	130.5	94.8	61.7				
20	154.1	169.0	150.4	165.3	145.9	111.8	94.8	61.4	43.0	26.4		
25	94.1	120.5	124.9	116.7	122.1	97.4	91.7	56.5	43.0	26.4		
30	64.3	81.5	97.6	78.3	93.1	85.5	83.5	51.6	43.0	26.4	20.9	
35	47.2	60.2	72.0	57.6	70.6	74.6	72.5	47.6	43.0	26.0	20.9	13.6
40				42.6	53.9	61.2	57.2	43.5	43.0	25.1	20.9	13.6
45				32.9	43.2	50.1	45.9	40.8	43.0	23.4	20.9	13.6
50				25.3	34.9	41.6	38.1	37.8	39.8	21.9	20.9	13.6
55				19.6	28.4	34.9	31.9	35.2	34.8	20.4	20.6	13.6
60				15.3	23.3	29.6	26.5	32.8	29.3	19.2	19.9	13.6
65				11.5	18.8	25.4	21.3	29.1	25.7	18.2	19.0	13.6
70				8.2	15.2	21.8	17.6	25.4	22.2	17.0	18.0	13.6
75							14.5	22.2	18.7	15.9	17.1	13.4
80							11.9	19.4	15.4	15.0	16.2	13.1
85							9.4	16.9	12.7	14.3	15.0	12.5
90							7.5	14.8	10.9	13.7	13.1	12.0
95							5.7	12.9	9.3	12.9	11.0	11.5
100								11.2	7.5	12.1	9.2	10.7
105								9.6	5.7	11.4	7.9	9.2
110									4.9	10.2	6.4	7.9
115										9.1		6.6
120										8.0		
125										6.9		
130	B1	B		B						5.9		

Hook elevation diagram

Main boom

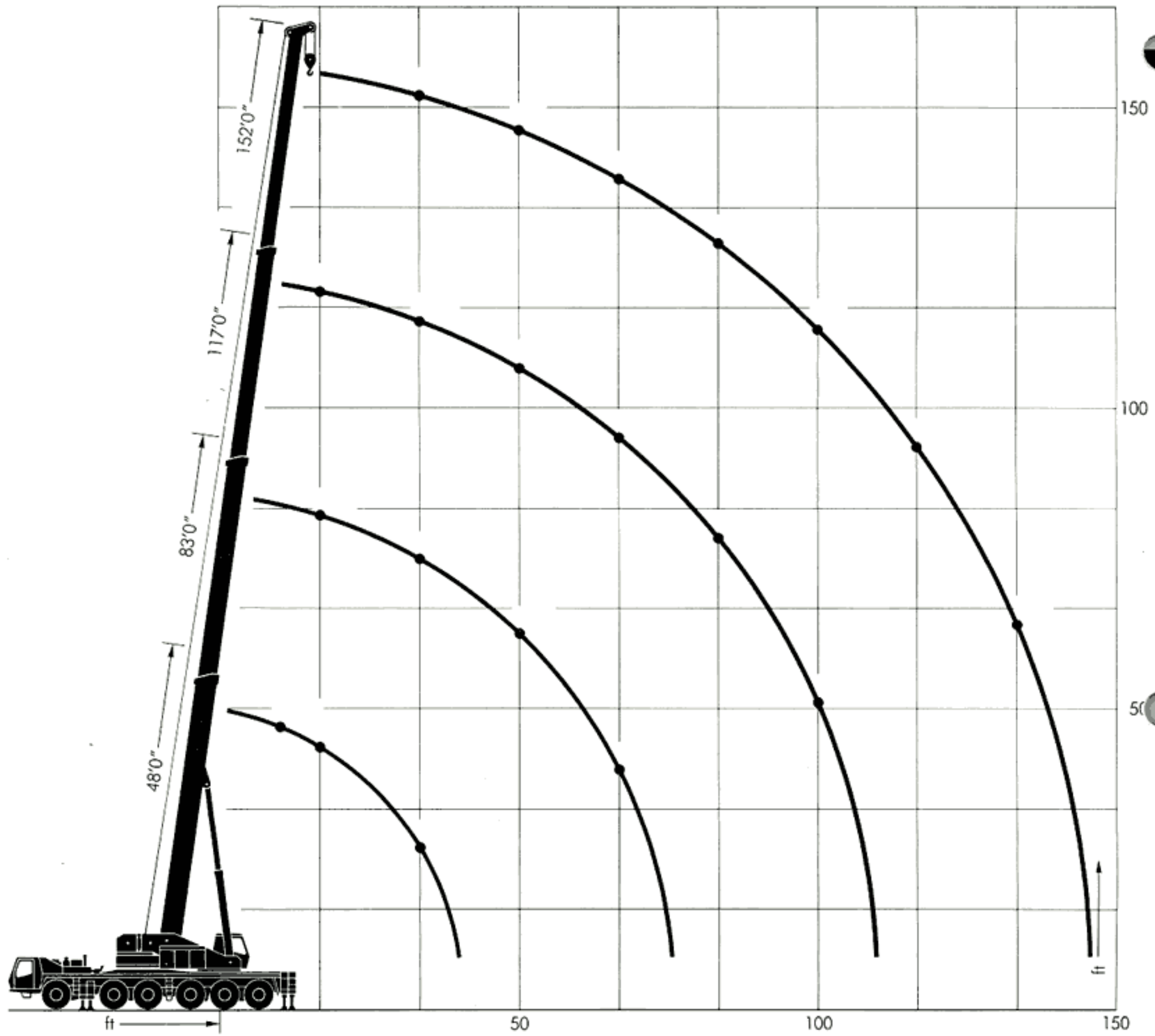

Hooks

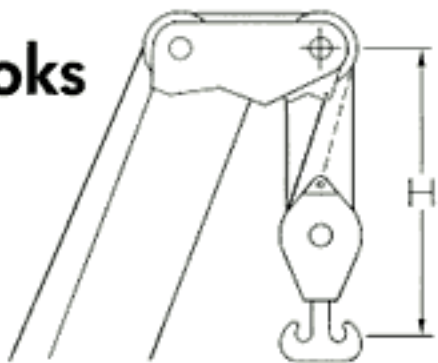

Capacity	ton	155	90	35
Sheaves		8	4	1
Distance H	ft	7'6"	7'6"	5'10"
Weight	ton	2.2	1.2	0.6

Hook elevation diagram

Power luffing jib

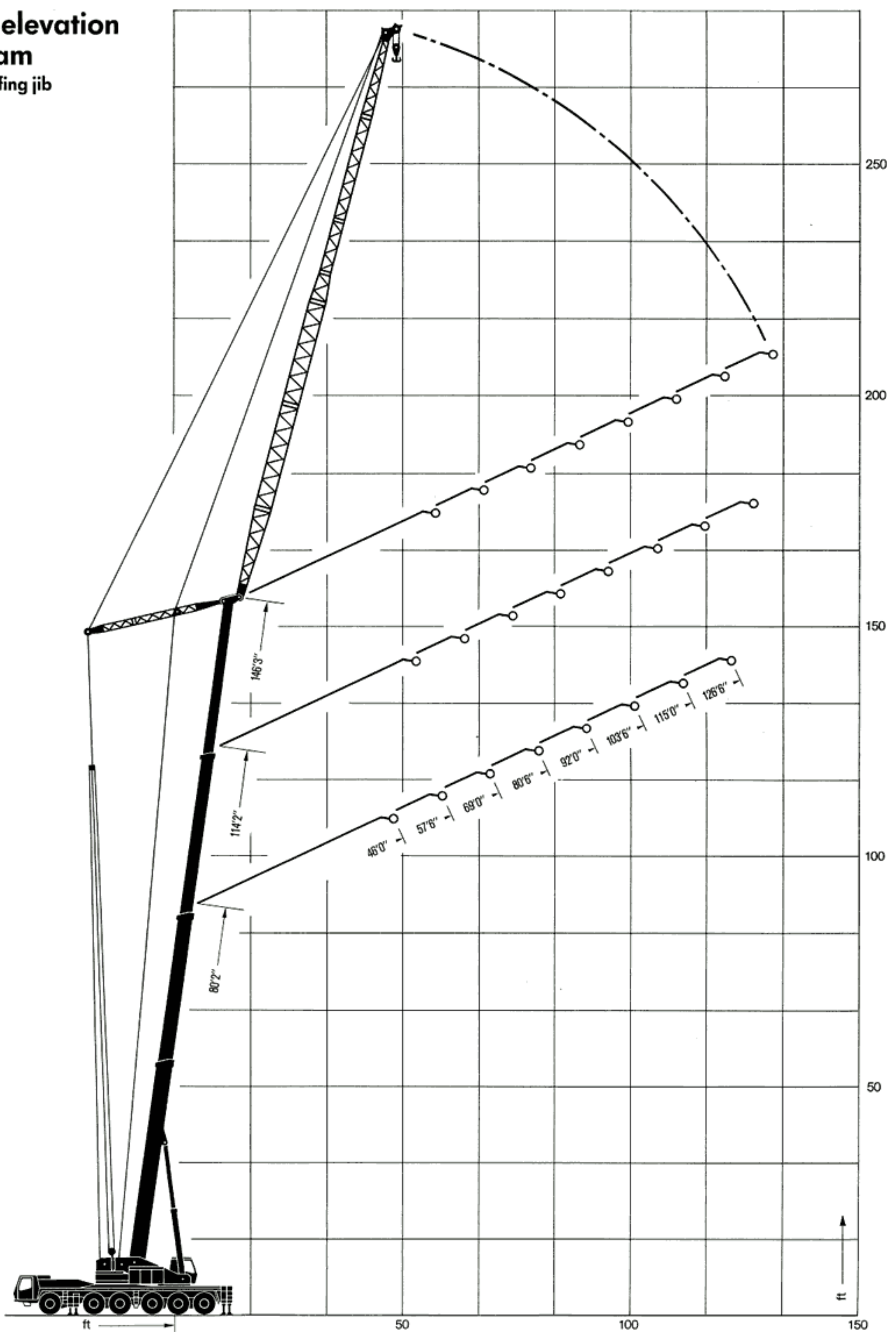

Lifting capacities in 1000 lbs on outriggers

360° Power luffing jib

Counterweight 46,300 lbs

	Radius	Jib length (ft)							
	(ft)	46'0"	57'6"	69'0"	80'6"	92'0"	103'6"	115'0"	126'6"
Boom length 80'2"	30	78.2	66.1						
	35	77.0	66.1	56.0					
	40	73.7	65.6	56.0	46.5	38.8			
	45	65.4	61.4	56.0	46.5	38.8	33.9		
	50		55.8	54.0	46.5	38.8	33.9	29.1	24.6
	55			49.9	46.0	38.8	33.9	29.1	24.6
	60			44.4	44.4	38.8	33.9	29.1	24.6
	65			40.2	40.2	38.8	33.9	29.1	24.4
	70				36.7	36.1	33.9	28.3	23.1
	75				33.8	33.1	32.6	27.0	21.8
	80					30.3	30.3	25.4	20.6
	85					28.3	28.1	23.9	19.2
	90						26.1	22.3	18.0
	95						24.3	20.9	16.9
	100							19.5	15.7
	105								14.7
	110								13.7
	Boom length 114'2"	35	39.0						
40		39.0	32.6						
45		39.0	32.6	27.5	23.5				
50		39.0	32.6	27.5	23.5	20.5			
55			32.6	27.5	23.5	20.5	17.4		
60			32.6	27.5	23.5	20.5	17.4	15.0	12.7
65				27.5	23.5	20.5	17.4	15.0	12.7
70				27.5	23.5	20.5	17.4	15.0	12.7
75					23.5	20.5	17.4	15.0	12.7
80						20.5	17.4	15.0	12.7
85						20.5	17.4	15.0	12.7
90						20.5	17.4	15.0	12.7
95							17.4	15.0	12.7
100							17.4	15.0	12.7
105							17.4	15.0	12.7
110							15.0	12.7	
115								12.7	
120								12.7	
125								12.7	
Boom length 146'3"	45	18.3	15.2						
	50	18.3	15.2	12.7					
	55	18.3	15.2	12.7	10.5				
	60	18.3	15.2	12.7	10.5	8.5	7.2		
	65		15.2	12.7	10.5	8.5	7.2	5.9	
	70			12.7	10.5	8.5	7.2	5.9	4.8
	75			12.7	10.5	8.5	7.2	5.9	4.8
	80				10.5	8.5	7.2	5.9	4.8
	85				10.5	8.5	7.2	5.9	4.8
	90					8.5	7.2	5.9	4.8
	95					8.5	7.2	5.9	4.8
	100						7.2	5.9	4.8
	105						7.2	5.9	4.8
	110						7.2	5.9	4.8
	115							5.9	4.8
120							5.9	4.8	
125								4.8	
130								4.8	

Outrigger base 29'6"

Rated loads do not exceed 75% of tipping load.

Lifting capacities are based on boom sections locked by remote control.





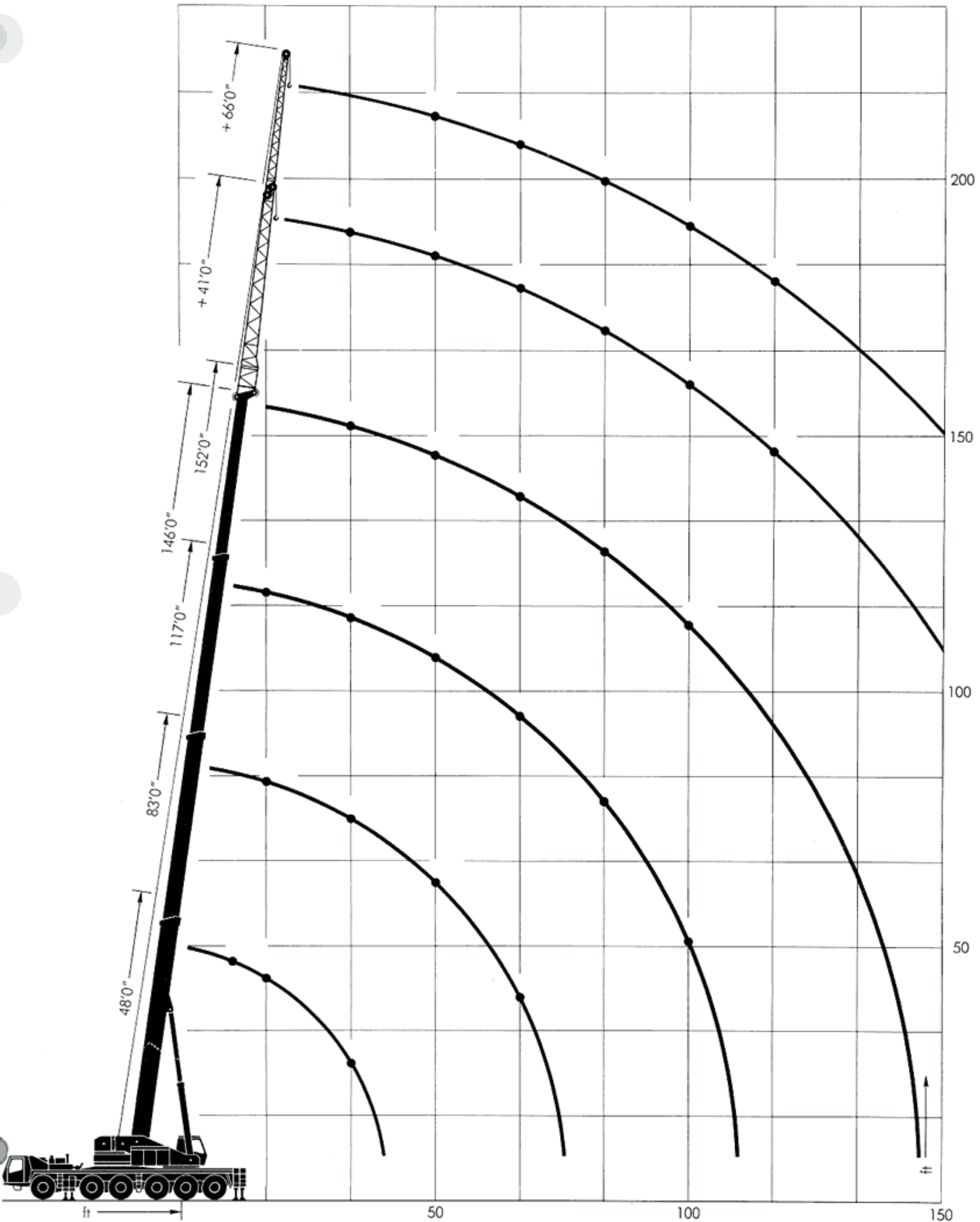



Hook elevation diagram

Main boom + 2-stage swing away lattice extension



Krupp Hydraulic Mobile Cranes

Product Range

Truck Cranes	Max. lifting capacity	Max. hook height
100 GMT 	120 ton	220 ft*
180 GMT 	250 ton	320 ft*
250 GMT 	365 ton	345 ft*
350 GMT 	450 ton	365 ft*
500 GMT 	600 ton	430 ft*
All-Terrain Cranes		
25 GMT-AT 	25 ton	122 ft
35 GMT-AT 	35 ton	129 ft
70 GMT-AT 	80 ton	178 ft
140 GMT-AT 	165 ton	296 ft*

* incl. power luffing jib

Krupp Industries Inc.
1370 Washington Pike
Bridgeville, Pa. 15017/USA

Telephone (412) 221-7041
Telex 6818083
Telefax (412) 221-7684

Krupp Canada Inc.
98 Columbus Street
Pointe Claire, Que. H9R 4K4/Canada

Telephone (514) 694-4740
Telex 05-822881
Telefax (514) 694-5280

Subject to technical modifications without notice