

# National Series 11000



**An extra-heavy-duty telescoping crane from National,  
America's truck-mounted hydraulic crane leader**

- Maximum Capacity: 56,000 Pounds (25.4 Metric Tons)
- Maximum Vertical Reach: 151 Feet (46.0 Meters)

## Why buy the ALL NEW National Series 1100 Telescoping crane?

### Here are some excellent reasons...

- The Series 1100 is the premier crane of its class in the commercial truck-mounted industry.
- The Series 1100 has a rated capacity of 56,000 pounds (25.4 MT).
- The Series 1100 has extra-long vertical reach—to 104 feet (31.7 m) under hydraulic power.
- With the 48-foot (14.6 m) jib, the 1195 reaches up to a vertical height of 151 feet (46.0 m).
- The PAT Model DS150 Load Moment Indicator (LMI) is standard on the Series 1100. The LMI provides the operator with a continuous reading of the crane's capacity as it moves through the motions required to make a lift. When the load capacity is approached, a caution light illuminates on the console. When the capacity is reached, an audio/visual alarm alerts the operator to take corrective action and the LMI deactivates functions that could contribute to an overload. The system automatically adjusts when overloads are relieved, allowing the use of all crane functions to resume.
- Standard and rear-mount dual operator controls offer the ultimate in fine metering and low spool force. The stand-up operator stations leave the truck bed free for payload.
- A split (two-piece) removable front console cover allows easy access to valves and wiring.

### And here are even more...

#### Field-proven durability

- National has manufactured cranes since 1963. Over 90% of all Nationals ever manufactured are still in operation, performing the jobs for which they were originally designed.

#### Attention to quality

- National never skimps on quality. The materials and components used in the manufacture of National cranes often cost more—sometimes significantly more—than those found in competitive products. When you buy a National, you get more for each dollar that you invest in your crane.

#### Industry-leading test program

- Each prototype model must pass the stringent test requirements of SAE J1063.
- National's test program subjects all prototype cranes to state-of-the-art stress coat and strain gauge testing, a procedure that measures metal deformation as small as one-millionth of an inch. These and the test procedures noted below verify the structural integrity of the cranes National manufactures.
- Prototype cranes must undergo National's life-cycle tests, the toughest in the industry. They receive more punishment than most cranes encounter in a lifetime of rigorous, on-the-job use. Every structural part of the crane is cycle tested.

Some components are operated through 60,000 cycles at full capacity load. The process requires thousands of working hours and takes months to complete.

- Boom corner seam welds on all Nationals are ultrasonically tested to verify proper boom weld penetration.

#### Rigid quality controls

- Each Series 1100 undergoes numerous quality inspections at all levels of manufacture and assembly. No crane is shipped without a rigid final inspection.
- Component manufacturers are subjected to critical review by National's senior management before they can qualify as a supplier of National parts.
- Inspections of incoming materials and components ensure that purchased items will meet National's demanding specifications.
- Material certifications are maintained and steel composition is regularly verified.
- All structural welders at National must pass AWS Welder certifications.
- All tooling and instruments used in the manufacture of National cranes are calibrated and verified to ensure parts consistency.

#### More value for your investment

- Nationals consistently have the highest resale value in the industry. You will realize a greater return on your crane investment when you trade or sell your used National.

## Uncompromising Standards Unequaled Performance

#### Responsive service

- Each Series 1100 is backed by strong after-sale and service support. National's professional dealer network is worldwide. That means service and repair resources are always near, wherever you may be operating your National.
- The typical National dealer has been associated with National for more than 11 years. He knows the product.
- Authorized National dealers maintain a parts stocking program for your crane. That means when your Series 1100 needs parts or service, it will be back on the job without undue frustration or delay.
- When a dealer cannot immediately supply a part for your Series 1100, the factory can. National is committed to providing 24-hour parts shipping in 92% of all breakdown rush orders.

#### Efficient boom design

- Computer-aided design allows the crane to achieve higher lifting capacities by maximizing the weight efficiency of Series 1100 booms.

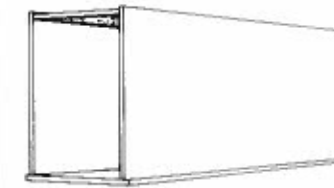

- The boom sections are fabricated from four high-strength steel members welded with perpendicular corners. This "Box-section" design utilizes thicker top and bottom plates to enhance boom strength and thinner side



plates to increase the crane capacity through lower boom weight.

- Only high strength, low-alloy steel is used in boom fabrication.
- Welds are made with automatic, low hydrogen techniques to ensure strong fatigue-resistant seams.
- Large bolt-in wear pads impregnated with lubri-

cants provide a smooth, long-life operation and are easy to replace. The wear resistance of the material used in Series 1100 pads is unexcelled by competitive models.

#### Stronger, more efficient sheaves

- The sheaves on the Series 1100 consist of iron, not plastic (as is used for the sheaves of most competi-

tive cranes). Iron sheaves afford greater strength and longer wear, resist flange chipping, and help prevent core damage to the wire rope.

- Two lower sheaves in the sheave case allow for four-part reaving (with optional block) without attaching additional equipment at the end of the boom.

## National Series 1100



### Four-section proportional boom extension system

- The Series 1100's four-section proportional boom, pioneered by National, sets up fast, provides extra-long hydraulic reach, and affords heavy-duty lifting power.
- Dual high load-carrying cables cycle the fourth stage boom. All other sections are supported by the hydraulic cylinder. Redundant cable sets are used for durability and reliability. The internal bearings and cable require no lubrication.
- Proportional (cable crowd) boom design (each boom extends and retracts proportionally during the telescoping operation) provides more efficient boom weight distribution, maximizing boom operational efficiency and allows higher capacities, particularly in normal working radii.
- The design permits minimum overlap to get the most reach with minimum retracted length. It reduces boom overhang (when the boom is stowed) and allows increased truck maneuverability.
- There are no fittings, tubes, or hoses inside the booms, and since the system utilizes only one extend cylinder, hydraulic maintenance is minimized.

### Direct mount holding valves

- On the Series 1100, all load-carrying cylinders are equipped with a direct mount holding valve for protection in the event of hose failure. The quiet, smooth and stable new boom cylinder holding valve ensures precise load placement with the boom.

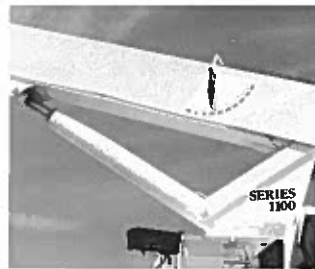

### National-manufactured cylinders

- Because National controls the manufacture of its own lift, outrigger, and stabilizer cylinders and the packing used as the seals, standardization is ensured and seal replacements fit properly.



### High performance planetary winch

- The standard high-performance gear drive winch increases efficiency, requires less horsepower, and generates less heat.

- The Series 1100 winch is powered by a premium, high-efficiency orbit (geroller) motor instead of the typical gear motor used on competitive cranes. The orbit motor used with National's high-performance winch, allows for extra-smooth control, up or down, even under maximum load.
- Anti-friction roller bearings have replaced bronze bushings, and spring-loaded lip seals have replaced O-rings to reduce leaks and maximize winch efficiency.
- A "Burst-of-Speed" feature for faster, more efficient pay-out and pick-up of unloaded cable is standard. A "Burst-of-Speed" winch circuitry increases line speed up to 60% over normal.
- The high capacity winch used on the Series 1100 features high line pull and fast standard speed (see winch data chart on page 9).
- Standard brake and counterbalance valves provide fine control.
- The winch cover permits visibility of the drum and cable.
- Die-drawn rotation-resistant wire rope (cable) is standard on the Series 1100. Even under full load, die-drawn wire rope minimizes spinning and twisting. Lifting operations are more precise and no time is wasted untangling the line. Die-drawn cable has a longer usable life span.



### Anti-Two-Block/Load Moment Indicator System

National's Anti-Two-Block (ATB) and Load Moment Indicator (LMI) share common components and work together to comprise a dual-purpose protection system that is standard on the Series 1100.

- Two blocking occurs when the winch cable and attachments contact the underside of the boom or jib sheave case, whether by winching up or extending the boom without paying out the winch cable. When this happens, the cable can be damaged by crimping or over-tensioning. The anti-two-block attachment helps prevent cable damage by sensing the position of the winch cable end attachments with respect to the sheave case and shuts down the functions that can cause two-blocking.

- The state-of-the-art PAT DS150 Load Moment Indicator offers a console display of boom length and angle, load on the hook, and available load capacity that can be lifted.



These features provide the operator with a continuous reading of the crane's capacity as it moves through the motions required to make a lift. An "Info Run" feature directs the operator to the console controls/functions and reminds the operator to perform basic machine set-up checks. A "swing arm" allows the console to be used at either operator station. A keyed override is provided for system operations in the event of emergency boom position. The system automatically adjusts when overloads are relieved to allow for the use of all functions. When a load capacity is approached, a caution light is illuminated on the console. When a capacity is reached, a red warning light and horn are activated, and the LMI halts crane movement to prevent overload. It allows only the use of functions that will relieve the overload condition (i.e., boom up, winch down, telescope in.)

## National Series 1100

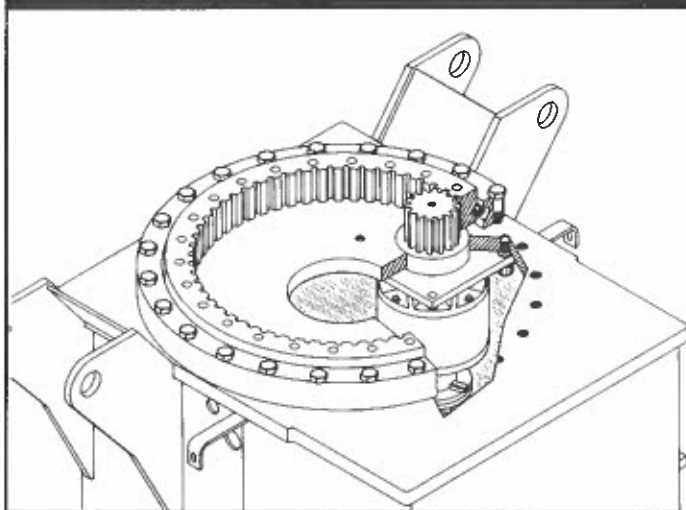

### Positive planetary turret rotation

- The planetary rotation gearbox with a hydraulic release brake and a slip-through feature allows the gearbox to backdrive when excessive side load is applied to the boom, reducing shock loads on the upper and lower crane structure and gearbox. This feature helps protect the rotation system against damage from accidental side loading.
- The turret drive is designed with extra-heavy bearings below the drive pinion. The turntable bearing full-circle bolt pattern extends the bearing life due to uniform loads on the bearing.
- The gearbox and rotation bearing mounting surfaces are precision-machined after welding to ensure consistent tooth alignment for smooth rotation and low wear, even under maximum loads.
- The entire turret glides smoothly on a low-inertia ball bearing race.
- Rotation is 375° non-continuous. The rotation stop design eliminates the sudden stop on non-continuous rotation machines by gradually slowing the rotation of the boom.

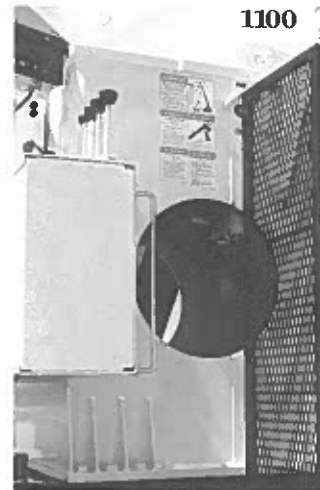

1100

### Smooth, "operator friendly" crane controls

- Dual controls are standard on the Series 1100. Identical crane function controls are located on each side of the crane. The controls are in an SAE recommended orientation of functions. That means that you always work the same control with the same hand.
- Dual stations provide more efficient operation of the crane and allow greater load visibility.
- Control rods supported by nylon bearings permit smooth operation of the crane and reduce lubrication requirements.
- National's control valves are custom manufactured



- to maximize the efficiency of each crane function. They afford the ultimate in fine metering and low spool force. The operator can winch a capacity load up or down in small increments of distance and can control all crane functions precisely and smoothly.
- The main control valve and the lift cylinder holding valve are designed to complement one another, minimizing boom bounce and hydraulic noise.
  - Labeled knobs make it easy for the operator to determine the function of each control.
  - The pressure gauge on the console permits the operator to monitor the hydraulic system pressure to ensure maximum performance.
  - The Series 1100 provides a precise leveling indicator at each control station.

- The level bubble brackets are machined to be parallel with the turntable bearing to properly level the unit prior to operation.
- A foot throttle, horn, and stop switch are located at each control station.
  - The operator's stations are positioned to allow easy reading of the angle indicator showing the boom angle during operation.
  - The platforms are located to give the operator excellent visibility of the load as well as convenient access to the bed. They are designed with open-mesh expanded metal to minimize dirt and mud buildup.
  - Extra high back rests at operator control stations aid in operator control and comfort.

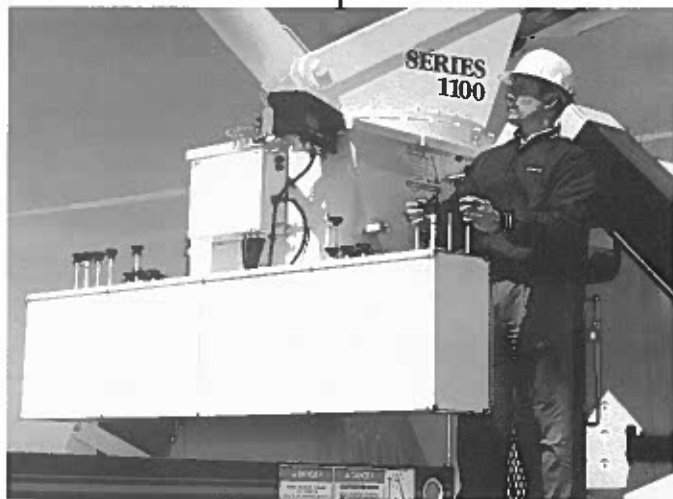

### National's "Out-and-Down" Stable Outriggers

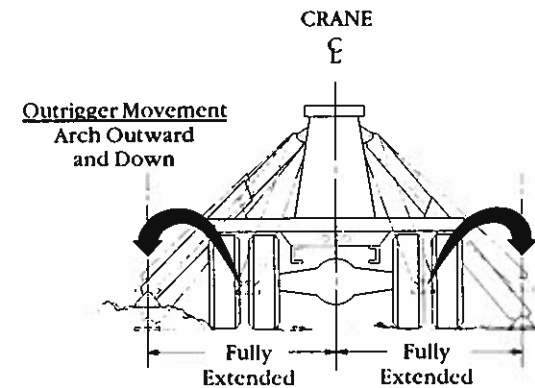

- Outriggers equally spaced from crane center line.
- Consistent outrigger span.
- Crane will be equally stable on both sides.
- No skidding the foot into position.



### Solid, reliable stability

- Wide 23-foot (7 m) span A-frame out-and-down outriggers provide stable, efficient leveling, even on uneven ground. Large 18 by 18 inch outrigger pads are standard.
- The outriggers retract smoothly without binding under load, first moving up, then in.
- With less truck weight you can carry larger payloads more economically.
- The Series 1100 is equipped with out-and-down rear hydraulic stabilizers with a 14-foot (4.3 m) span. Horizontal extension is controlled by

one cylinder. The vertical-down motion is controlled by two cylinders acting independently.



- Series 1100 stabilizers are designed to lift and level—or lower—a loaded truck without sticking or binding. Hoses are routed along the beam to prevent hose damage during operation of the crane.
- Stabilizer foot pad size is 8 x 14 inches. Leg travel is 25 1/2 inches, permitting good penetration with maximum ground clearance.
- A precision-mounted level indicator aids the operator in leveling the unit during the set-up procedure.

### Unitized mounting

- National's unitized mount includes a one-piece, 8 3/4 inch deep subbase that extends along the frame and supports the

- crane and bed. It reduces counterweighting and increases stiffness and stability.
- Reinforcing is not required on trucks with 15.9 inch (26.0 inch for 360° stability) section modulus frames of 110,000 psi minimum yield steel. The crane and subbase ship separately, then bolt together to form one solid integrated unit.

### Lower truck requirements

- The Series 1100 is engineered to lower your truck requirements. The wide outrigger span, out-and-down rear stabilizers, and unitized mount take the stress (and not the truck).
- That means that the Series 1100 can mount on trucks with lower axle ratings and still meet DOT and stability standards with ease. It all adds up to lower maintenance, lower costs, and longer truck life for you.
- The Series 1100 with subbase mounts on most standard, heavy-duty commercial trucks without requiring counterweight in most cases.

### Heavy-duty hydraulic system

- A standard high-pressure, high-speed balanced vane replaceable triple pump provides three separate (or individual) hydraulic circuits for independent operation of winch, swing, and crane functions. This increases productivity on high-cycle jobs while facilitating ease of operation. The vane pump is more efficient and less costly to repair than the gear pumps used by some competitors.
- Control valve spools are hard, chrome-plated for

long life and resistance to corrosion. All spools are selected and hone-fitted for minimum internal leakage and maximum load-holding ability.

### Versatile accessories

- A selection of boom/jib combinations (see the following section) allows you to tailor your Series 1100 to your job requirements.
- A complete accessory line adds to the versatility of the Series 1100. See page 14 for details.

### Easy service, low downtime

- The console cover allows easy access to control valves.
- Boom pivot and lift cylinder bearings provide longer life and lower maintenance.
- Boom access holes provide easy access to wear pads and holding valve for easy maintenance.
- The rotation drive and the brake are located inside the frame. A large access hole allows easy access for service.
- O-ring face seal fittings are used on all high pressure circuits to minimize fluid leakage.
- All pins are chromed to inhibit rust and allow easy removal.
- Greaseless bearings are used throughout to reduce maintenance.
- Extra-capacity (75 gallon) oil reservoir with sight gauge, breather, suction strainer, clean-out, and magnetic plug reduces heat buildup and keeps the hydraulic oil clean, ensuring ease of maintenance and long life. The aluminized reservoir prevents the gathering of rust in the system.

# National Series 1100 Booms and Jibs

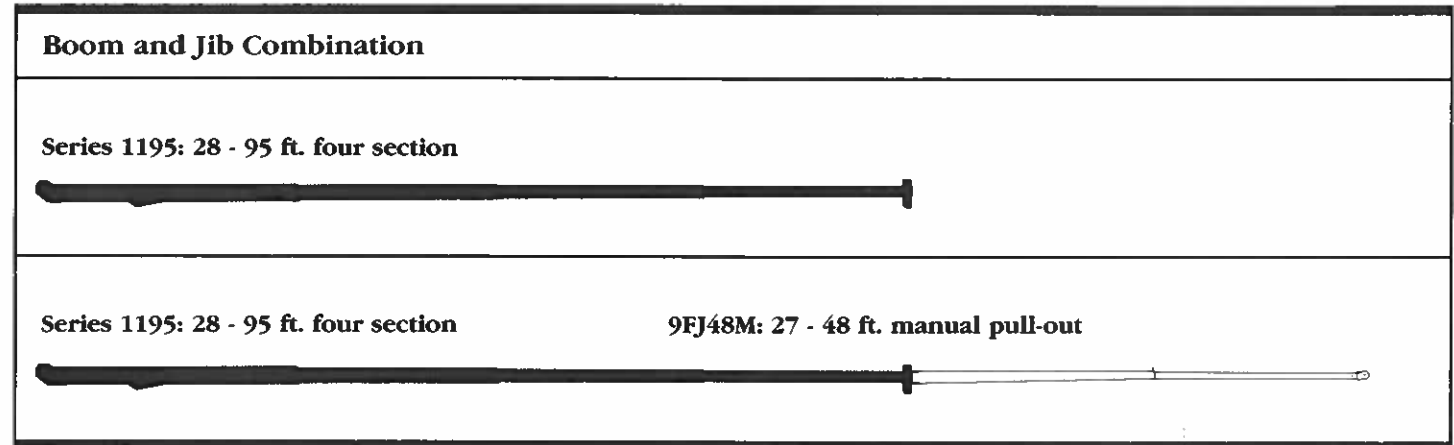

**Reaches to 151 feet**  
The Series 1100 is currently available in the two configurations shown above.

1. The Series 1100 with the 28-95 ft. four section boom.

2. Same as above with optional side-stowing jib: Model 9FJ48M, 27-48 ft. manual pull-out.

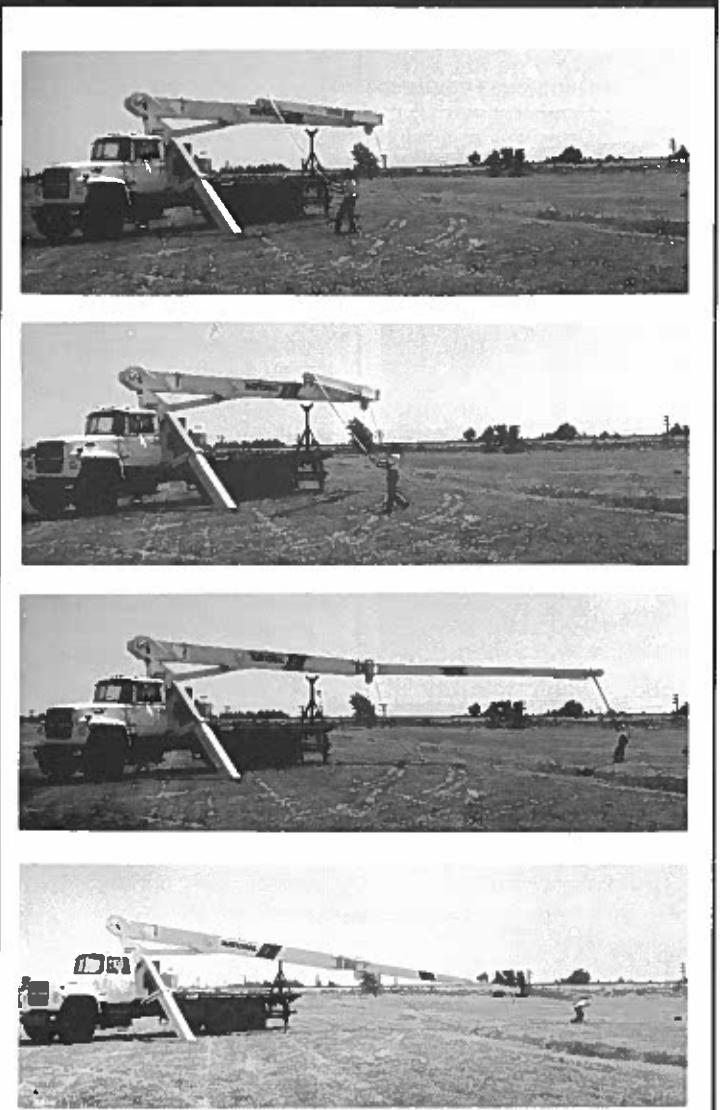

This sequence of photos shows how a National jib folds out into a working position.

# National Series 1100 Winch Data

National Series 1100 Winch Data			1 Part Line	2 Part Line	3 Part Line	4 Part Line	5 Part Line	6 Part Line	7 Part Line
<b>Caution</b>									
<ul style="list-style-type: none"> <li>Do not deadhead lineblock against boom tip when extending boom.</li> <li>Keep at least three wraps of loadline on drum at all times.</li> <li>Use only 9/16" diameter rotation resistant cable with 38,500 pounds breaking strength on this machine.</li> <li>Maximum capacity with "Burst-of-Speed" is 3,000 pounds on single part line.</li> </ul>									
Winch	Cable Supplied	Average Breaking Strength	Lift and Speed	Lift and Speed	Lift and Speed	Lift and Speed	Lift and Speed	Lift and Speed	Lift and Speed
Standard Planetary Winch	9/16" diameter rotation resistant 18 x 19 IWRC	38,500 lbs.	7,700 lbs. 164 fpm	15,400 lbs. 82 fpm	23,100 lbs. 55 fpm	30,800 lbs. 41 fpm	38,500 lbs. 33 fpm	46,200 lbs. 27 fpm	53,900 lbs.* 23 fpm
	optional 9/16" diameter 6 x 25 IWRC cable	33,600 lbs.	7,700 lbs. 164 fpm	15,400 lbs. 82 fpm	23,100 lbs. 55 fpm	30,800 lbs. 41 fpm	38,500 lbs. 33 fpm	46,200 lbs. 27 fpm	56,000 lbs. 23 fpm
with "Burst-of-Speed" Feature	Same as corresponding cable data shown above		3,000 lbs. 265 fpm	6,000 lbs. 133 fpm	9,000 lbs. 88 fpm	12,000 lbs. 66 fpm	15,000 lbs. 53 fpm	18,000 lbs. 44 fpm	21,000 lbs. 37 fpm

All winch pulls and speeds are shown on the fourth layer. Winch line pulls would increase on the first, second and third layers. Winch line speed would decrease on the first, second, and third layers. Winch line pulls may be limited by the winch capacity or the cable safety factor. These are shown below:

Winch	Bare Drum Pull	Allowable Cable Pull
With standard rotation resistant rope.....	10,000 pounds.....	7,700 pounds
With optional 6 x 25 IWRC rope .....	10,000 pounds.....	9,600 pounds

\* 56,000 pound load requires optional 9/16" diameter 6 x 25 IWRC cable.

- |  |   |  |  |
|--|---|--|--|
| <p><b>Do not operate crane booms, jib extensions, any accessories, or loads within 10 feet (3 m) of live power lines or other conductors of electricity.</b></p> | <p>1. Load ratings shown on these charts are maximum allowable loads with the outriggers properly extended on a firm, level surface and the crane leveled and mounted on a factory-recommended truck.</p> <p>2. Always level the crane with the level indicator located on the crane frame.</p> | <p>3. The operator must reduce loads to allow for factors such as wind, ground conditions, operating speeds and the effect of freely suspended loads.</p> <p>4. Overloading this crane may cause structural collapse or instability.</p> | <p>5. Weights of any accessories attached to the boom or loadline must be deducted from the load chart capacities.</p> <p>6. Do not exceed jib capacities at any reduced boom lengths.</p> |
|--|---|--|--|

# National Series 1100 Load Rating Charts

The capacities shown will be reduced when accessories are attached to the boom or loadline.

**Note:** Rated loads do not exceed 85% of the tipping load. Structural strength ratings in the chart below are shaded.

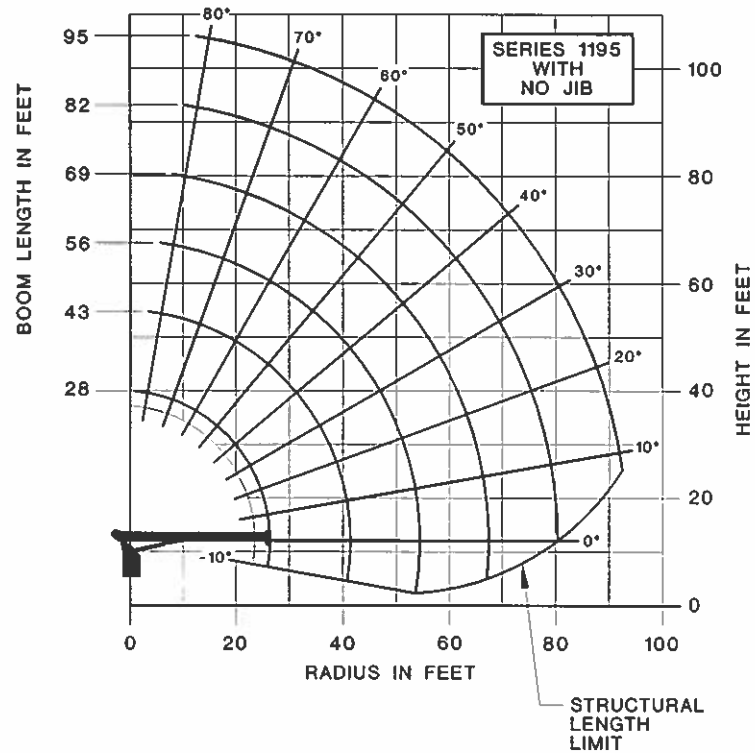

LMI OPERATING CODE SWITCH	
SWITCH POSITION	OPERATING MODE
01	MAIN BOOM - NO JIB STOWED
11	MAN BASKET ON MAIN BOOM

- NOTE:
- CAPACITIES DO NOT EXCEED 85% STABILITY.
  - SHADED AREAS ARE STRUCTURALLY LIMITED CAPACITIES.

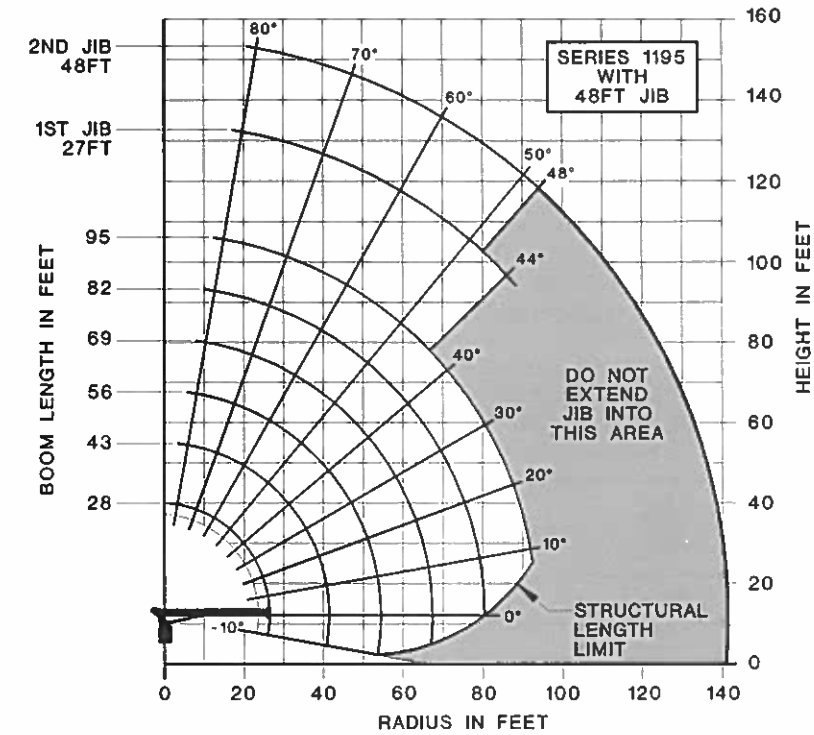

LMI OPERATING CODE SWITCH	
SWITCH POSITION	OPERATING MODE
01	MAIN BOOM - NO JIB STOWED
02	MAIN BOOM - JIB STOWED
03	27 FT TELE JIB
04	48 FT TELE JIB
11	MAN BASKET ON MAIN BOOM
12	MAN BASKET ON 27 FT TELE JIB
13	MAN BASKET ON 48 FT TELE JIB

- NOTE:
- OPERATE WITH JIB BY RADIUS, WHEN MAIN BOOM IS FULLY EXTENDED. IF NECESSARY INCREASE BOOM ANGLE TO MAINTAIN LOADED RADIUS.
  - OPERATE WITH JIB BY BOOM ANGLE WHEN MAIN BOOM IS NOT FULLY EXTENDED. DO NOT EXCEED RATED JIB CAPACITIES AT ANY REDUCED BOOM LENGTHS.
  - CAPACITIES DO NOT EXCEED 85% STABILITY.
  - SHADED AREAS ARE STRUCTURALLY LIMITED CAPACITIES.

LOAD RATINGS												LOADLINE EQUIPMENT DEDUCT		
LOAD RADIUS (FEET)	LOADED BOOM ANGLE	28FT BOOM (LBS)	LOADED BOOM ANGLE	43FT BOOM (LBS)	LOADED BOOM ANGLE	58FT BOOM (LBS)	LOADED BOOM ANGLE	69FT BOOM (LBS)	LOADED BOOM ANGLE	82FT BOOM (LBS)	LOADED BOOM ANGLE	95FT BOOM (LBS)		
5	78.5	53,900*												
8	71.5	40,300												
10	67	33,700	78	30,600										
12	62.5	28,900	73.5	26,200	78	24,000								
14	57.5	25,400	70.5	23,000	76	21,000	79	18,000						
16	52	22,400	67.5	20,400	73.5	18,700	77.5	17,000	80	14,500				
20	40	17,700	61.5	16,700	69	15,300	74	13,900	77	12,500	79	10,200		
25	17.5	11,900	53	13,500	63.5	12,400	69.5	11,400	73.5	10,600	76	8,000		
30			43.5	11,000	57.5	10,400	65	9,800	69.5	9,900	73	8,000		
35			32	8,800	50.5	8,800	60	8,200	66	7,500	70	7,000		
40			15.5	8,200	44	7,500	55	7,100	62	6,900	66.5	6,100		
45					35.5	6,100	50	5,950	58	6,850	63	6,300		
50					24.5	4,900	43.5	4,950	53.5	4,750	59.5	4,800		
55							37	4,100	48.5	4,000	56	4,000		
60							28.5	3,350	43.5	3,400	52	3,400		
65							18.5	2,600	37.5	2,800	47.5	2,850		
70									31	2,300	43	2,350		
75									22.5	1,900	38	1,950		
80											32.5	1,550		
85											26	1,250		
90											16.5	950		
90	0	6,200	0	2,900	0	1,450	0	850						

\* 56,000 pound load requires optional 9/16" diameter 6 x 25 IWRC cable.

LOAD RATINGS														LOADLINE EQUIPMENT DEDUCT			
LOAD RADIUS (FEET)	LOADED BOOM ANGLE	28FT BOOM (LBS)	LOADED BOOM ANGLE	43FT BOOM (LBS)	LOADED BOOM ANGLE	58FT BOOM (LBS)	LOADED BOOM ANGLE	69FT BOOM (LBS)	LOADED BOOM ANGLE	82FT BOOM (LBS)	LOADED BOOM ANGLE	95FT BOOM (LBS)	LOAD RADIUS (FEET)	LOADED BOOM ANGLE	27FT JIB (LBS)	LOADED BOOM ANGLE	48FT JIB (LBS)
5	78.5	53,900*											30	77.5	6,200	80	3,200
8	71.5	40,300											35	75.5	4,800	78.5	3,050
10	67	33,700	78	30,100									40	73	4,350	76.5	2,850
12	62.5	28,900	73.5	25,800	76	23,700							45	70.5	3,900	74.5	2,850
14	57.5	24,800	70.5	22,800	76	20,700							50	68	3,500	72.5	2,450
16	52	21,800	67.5	20,000	73.5	18,400	77.5	16,700	80	14,300			55	65.5	3,050	70.5	2,300
20	40	17,100	61.5	16,300	69	15,000	74	13,900	77	12,300	79	10,000	60	62.5	2,550	68	2,160
25	17.5	11,200	53	13,100	63.5	12,100	69.5	11,100	73.5	10,300	76	8,800	65	60	2,100	66	2,000
30			43.5	10,800	57.5	10,100	65	8,300	69.5	8,700	73	7,800	70	57	1,750	64	1,860
35			32	8,400	50.5	8,500	60	7,900	66	7,300	70	6,800	75	53.5	1,400	61.5	1,600
40			15.5	5,800	44	7,200	55	6,800	62	6,400	66.5	5,900	80	50.5	1,100	59	1,350
45					35.5	5,800	50	5,650	58	5,450	63	5,100	85	47	800	58	1,150
50					24.5	4,800	43.5	4,650	53.5	4,550	59.5	4,400	90	44	600	53.5	950
55							37	3,800	48.5	3,800	56	3,800	95			50.5	750
60							28.5	3,050	43.5	3,200	52	3,200	100			48	600
65							18.5	2,300	37.5	2,600	47.5	2,650					
70									31	2,100	43	2,150					
75									22.5	1,700	38	1,750					
80											32.5	1,350					
85											26	1,050					
90											16.5	750					
90	0	6,200	0	2,500	0	1,150	0	350									
ADD TO CAPACITIES WHEN NO JIB STOWED (LBS)		600		400		300		300		200		200					

\* 56,000 pound load requires optional 9/16" diameter 6 x 25 IWRC cable.

# National Series 1100 Truck Specifications

	Configuration 1 with Torsion Box	Configuration 2 with Torsion Box
<b>Mounting Configurations</b> The versatility of the Series 1100 can be enhanced by the mounting configurations described at the right. The configurations are based on the Series 1100 with an 85% stability factor. The complete unit must be installed in accordance with factory requirements and a test performed to determine actual stability and counterweight requirements since individual truck chassis vary.	This configuration is the least expensive mounting method for the Series 1100. This mount, with the crane mounted behind the truck cab, requires the least weight of all mounts for stability, thus, you can haul larger payloads on your truck. It requires standard subbase and rear (RSOD) stabilizers.	This mount requires front stabilizers to give the machine full capacity 360° around the truck. Care must be taken in the selection of the truck. It must meet the minimum requirements shown below. The front stabilizer gives the machine a solid base, helping the operator control the loads precisely. Requires front and rear down-and-out stabilizers and a subbase. The truck frame must be made from 110,000 psi steel. See "Truck Frame and Mounting Bolt Requirements for Front Stabilizer" statement on page 13. Contact the factory for details.
Stable	180°	360°
Gross Axle Weight Rating (GAWR), front	18,000 lbs.	18,000 lbs.
Gross Axle Weight Rating (GAWR), rear	34,000 lbs.	34,000 lbs.
Wheelbase (WB)	246 inches	246 inches
Cab to axle/trunnion (CA/CT)	168 inches	168 inches
Frame Section Modulus (SM) under crane 50,000 PSI or	35.0 inch <sup>3</sup>	Not applicable (see note above)
----- 110,000 PSI	15.9 inch <sup>3</sup>	26.0 inch <sup>3</sup>
Frame Section Modulus (SM) over rear stabilizers: 50,000 PSI or	17.0 inch <sup>3</sup>	Not applicable (see note above)
----- 110,000 PSI	13.0 inch <sup>3</sup>	13.0 inch <sup>3</sup>
Stability Weight, Front	7,900 lbs. minimum*	7,900 lbs. minimum; 10,760 lbs. maximum*
Stability Weight, Rear	9,700 lbs. minimum, RSOD*	9,700 lbs. minimum, RSOD*
Estimated Average Final Weight	40,600 lbs.	40,600 lbs.
<b>NOTES:</b> (1) GAWR means Gross Axle Weight Rating and is dependent on all components of the vehicle such as axles, tires, springs, frame, etc. meeting manufacturer's recommendations. Always specify GAWR when purchasing trucks. (2) Minimum axle requirements may increase with use of longer wheelbase, service bodies, diesel engines or front stabilizers. (3) Diesel engines require variable speed governor and energize-to-run fuel solenoid for smooth crane operation.		
	* Estimated axle scale weights prior to installation of crane, stabilizers and subbase for 85% stability.	

# Warranty, Parts and Service

Configuration 3 with Torsion Box
The advantages of this rear-mounted Series 1100 are: (1) the operator can effectively use the close-in work area to lift heavier loads; and (2) 360° stability at full-rated load. Hydraulic out-and-down outriggers located behind the cab are necessary to keep the total weight of the unit to a minimum with full stability. This configuration requires front over frame outriggers, single rear outrigger and heavy-duty rear-mount subbase. Counterweight may be required to ensure stability. Contact the factory for details.
360°
16,000 lbs.
34,000 lbs.
246 inches
168 inches
35.0 inch <sup>3</sup>
----- 15.9 inch <sup>3</sup>
35.0 inch <sup>3</sup>
----- 15.9 inch <sup>3</sup>
9,250 lbs. minimum
8,550 lbs. minimum; 10,250 lbs. maximum*
42,600 lbs.

## Truck Frame and Mounting Bolt Requirements for Front Stabilizer

An extended frame truck must be used. Contact factory for details. Details for mounting a stabilizer on an extended frame truck are included in that installation instruction.

The truck frame must have adequate strength from under the crane frame through the front suspension to the bumper assembly for front stabilizer installation. A truck frame yield strength of 110,000 psi is required.

The following diagram shows the required section modulus at various stations along the front end of the truck frame for a standard behind-the-cab mount.

Note in the sample cross-section that the truck frame top flange width is decreased in the engine compartment area.

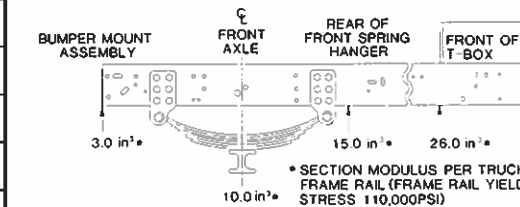

Extended Truck Frame

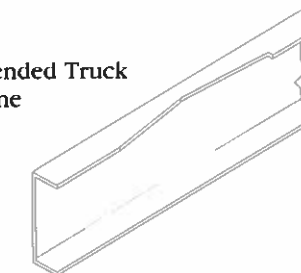

**Note:**  
Integral front frame extension is required for SFO (single front-mounted stabilizer) to provide 360° stability.

## The National Warranty

The National Warranty covers your crane against defects in materials and workmanship for six months from the date of shipment, subject to the conditions of the warranty.

When you purchase a National crane, you have—along with strong warranty protection and National's long-standing commitment to quality—access to our nationwide dealer warranty service network. Questions concerning the National warranty should be directed to:

National Warranty Service;  
11200 North 148th Street;  
Waverly, NE 68462.

## The National Parts System

Authorized National Crane dealers stock an inventory of parts to support the National cranes in their areas. If your dealer cannot immediately supply a needed part, the factory maintains a back-up program providing 24-hour parts shipping in 92% of all breakdown rush orders. National's responsiveness to dealer parts orders means that your crane will be back on the job without needless delay. National maintains a trained Service and Parts staff to answer dealer service questions and expedite parts shipping.

## The National Service Center

National maintains a fully equipped Service Center at its Waverly, Nebraska plant. Here, we do all factory crane mounting and handle special crane modifications or repairs. Most National dealers can accommodate all but the most unusual modifications or serious repairs. The Service Center gives each crane requiring repair, modification, or other service, priority attention to ensure that it's back on the job as soon as possible.

## National Series 1100 Accessories

Every Series 1100 is part of the National Lifting System, a select choice of accessories that add versatility to your crane. With National accessories you can tailor your crane to handle your specific job requirements. In many instances, a truck-mounted crane equipped with accessories can eliminate your need for other specialized equipment.

Because your Series 1100 affords such versatility, you save time, money, and manpower. You can do more, faster, with less equipment. National accessories are, thus, cost-efficient options.

### Note:

Weights of all accessories attached to the boom or loadline of the crane must be deducted from the effective lifting capacity. Consult your National dealer for specific accessory availability. Some accessories cannot be used in combination with other accessories and/or certain boom/jib combinations.

### Caution:

Do not operate crane booms, jib extensions, any accessories, or loads within 10 feet (3 m) of live power lines or other conductors of electricity. Do not exceed jib capacities at any reduced boom lengths.



### Remote Control

National offers one-hand remote control for your Series 1100. Ideal for use where precise control and total load visibility are required.

Fine metering and instant response mean operators can position loads or work platforms easily.

National's remote controls are built with solid state circuitry and few moving parts. They are designed for reliability. You will be impressed with the high operating speeds and modular design.

Available in two models: R4 with tilt, turn, telescope and winch functions, and R3 with tilt, turn, and telescope only. R3 is to be used to control cranes from basket.

A priority control valve, operated by a trigger on the remote control unit, regulates oil flow and gives you fingertip speed control over all crane functions.

National's remote control is the lightweight, easy-to-use way to add extra versatility to your crane. Consult your dealer or the factory for availability.

#### Model R3

Tilt, turn and telescope

#### Model R4

Tilt, turn, telescope and winch



### Radio Remote Control

National also offers a radio remote control for all crane models, eliminating handling and maintenance concerns that accompany cabled remotes. Coded FM signal operates to a range of approximately 400 feet (varying with conditions).

#### Model R3

Tilt, turn, telescope

#### Model R4BR

Tilt, turn, telescope and winch

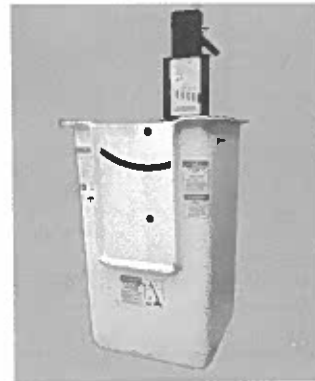

### One Person Basket

Strong, lightweight fiberglass basket puts personnel where you want them for tough maintenance and installation jobs. Optional dual basket bracket for two-basket operation on main boom. Easy on-off. Body belts included.

#### Model B1-L

With lock



### Heavy-duty Personnel Basket

New high-capacity steel personnel basket provides safety loops to secure up to four passengers. Dimensions are 72" x 42" x 42". This basket is ideal for lifting personnel with tools or materials to aboveground jobsites. A new fast-attachment system allows fast, easy pinning of basket to the boom. The gravity-leveling basket has a new, secure disc-brake locking system.

#### Model BSA-1

### Note:

Personnel basket/platform operation limits vary based on the crane configuration and platform/basket type. Refer to Owner's Manual for complete details and operation restrictions.

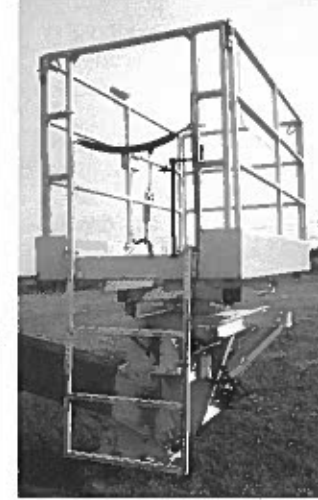

### Personnel Platform

This extra strength 3 x 6-foot steel platform will operate at working heights up to 108 feet (32.8 m). It is hydraulically self-leveling and protected by safety valves. Body belts included. Fold down sides standard.

Optional manual rotator available for precise placement of the platform. Easy-to-operate crank rotates the platform through a dependable chain drive. Continuous rotation. Locks in position.

The personnel platform can be used with angling jib for additional reach.

#### Model SLP

#### Model SLPR

### Hydraulic Oil Cooler

Automatic hydraulic device designed to cool the oil under high-cycle operation.

#### Model HOC

### Stabilizers

We offer a complete range of front and rear stabilizers with hydraulic vertical and horizontal motion. All cylinders are fully enclosed for protection against dirt and on-the-job damage.

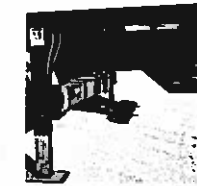

Rear Mounted  
(Model RSOD)

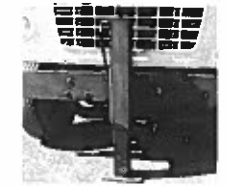

Front Mounted\*  
(Model SFO Fixed)



Rear Mounted  
(Model SRO)

### Stabilizers

Vertical Travel.....	25 1/2"	25"	25"
Ground Penetration (38" Frame Height).....	10"	13"	8"
Operation .....	All-Hydraulic	All-Hydraulic	All-Hydraulic
Span .....	14'	Single	Single
Controls .....	All stabilizers indicated can be operated from either control station.		

### Cross-frame Outriggers

Extended Span .....	17'4"
Retracted Span .....	7'5"
Vertical Travel.....	24'5"
Ground Penetration (38" Frame Height) .....	14"



Cross-frame outrigger for behind-cab use with rear-mount crane.

\* The SFO is a single front-mounted hydraulic stabilizer. It is not designed to lift the vehicle, but will provide stability for the vehicle after it has been leveled. Model SFO requires an extended chassis frame.

### Pallet Fork

Turns your Series 1100 into a versatile, payload-packing fork lift. Great for delivering palletized material right where you want it. 4,400 lbs. (1,996 kg) capacity with adjustable throat and teeth. Handles most loads with ease.

Capacity:	4,400 lbs. at 20" center
Throat Opening: (adjustable)	41" to 65"
Tooth Length:	38"
Tooth Width: (outside to outside)	33.5" to 37" min. max.
Weight:	350 lbs.

### Model MKF

(Manual leveling, adjustable throat)



### Loose Material Clam Bucket

Increase the flexibility of your Series 1100 with a National clam bucket. Use this versatile accessory to load or move up to 2/3 cubic yard of loose materials with each bite. Hooks easily to loadline, comes with hydraulic hose on automatic reel and quick-connect fittings. Extension hoses are required for use with jibs. Just position the load where you want it and open the bucket.

### Model LMC

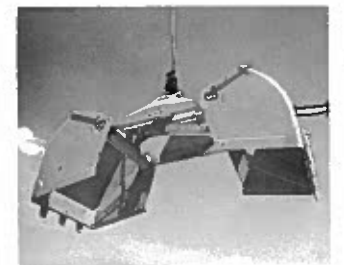



# National Series 1100 Specifications

## General Construction:

Low-alloy, high tensile, and other steel including T-1, Ex-Ten, Stressproof and Hi-Yield are combined with special low-hydrogen welding techniques wherever advantageous. Standard color: Painted National Ivory.

## Frame:

Box construction for maximum strength and rigidity.

## Turret:

Fabricated rigid structure, well-braced for stability. Line-bored and machined after welding to ensure proper alignment.

## Rotation:

375° rotational force 450,000 in./lb. Turret rotation is by hydraulic orbit motor and planetary gearbox driving a pinion. The turret rotates on a ball-bearing race. Spring-applied-hydraulic release brake provides positive, no-drift lateral positioning.

## Subbase:

Unitized box construction designed to increase torsional stiffness and reduce truck frame requirements. Standard subbase is designed to fit on standard 34" wide truck frame and will accommodate a 20' stringerless bed. Attaches both to truck frame and crane frame. Total depth of subbase is 8 3/4".

## Outriggers:

"A" frame box-type, 23' span (center of pad at ground level) move out and down, will not bind when raising or lowering truck. Can be positioned to 9" below ground level on 38" truck frame height.

## Tilt:

Double-acting hydraulic cylinder raises and lowers boom; butt-mounted safety holding valve prevents boom falling in event of hose failure. Heavy-duty, long-life pivot bearings.

## Boom:

Boxed construction; telescopes proportionally under rated load on nylon plates impregnated with molybdenum disulfide for smooth, long-life operation. Boom cylinder and valves are easily serviced. Heavy-duty, long-life pivot bearings.

## Winch:

Hydraulic geroller motor with planetary gear reduction brake and counterbalance valve for "power down" load lowering. 10,000 lbs. bare drum single-line pull available with 320 ft. of 9/16 inch, 19.25 ton breaking strength loadline. "Burst-of-Speed" control increases payout and pick-up of unloaded cable 60% over normal operating speed.

## Pumps:

Triple Vickers, high pressure, high-speed balanced-vane, replaceable cartridge-type, providing 23 gpm to crane functions, 8 gpm to rotation, and 34 gpm to winch.

## Cylinders:

Shaft packing: Polyurethane cup type. Shafts: HiYield stress-relieved, chrome-plated. Piston sets: Polyurethane u-cups with glass-reinforced nylon bearings. Cylinder barrels: Microhoned tubing and safety check valves.

## Valves:

Four-way, spring-centered, spool type with low spool force and extra-fine metering notches. Independent relief valves protect hydraulic circuit against overload. Relief valves set at: 3200 psi on crane functions; 2500 psi on rotation system, and 3050 psi on winch system. Valves located for improved accessibility and ease of service.

## Hose:

All high-pressure hose is wire braid reinforced, having a minimum safety factor of 4 to 1.

## Operating Speeds:

Winch 3rd wrap: 150 fpm. Boom up and down: 27-31 seconds. Boom out: 28 ft. to 95 ft. in 98 seconds. Boom in: 95 ft. to 28 ft. in 91 seconds. Turn: 50 seconds. When using remote control, crane function speeds will be reduced by 40% to assure smooth operation. (Speeds above are nominal values and may vary, they assume no load with 23 gpm oil flow on boom, 8 gpm on rotation and 34 gpm on winch.)

## Oil Tank Capacities:

75 gallon supply tank with breather, clean-out, suction strainers and removable magnetic plug.

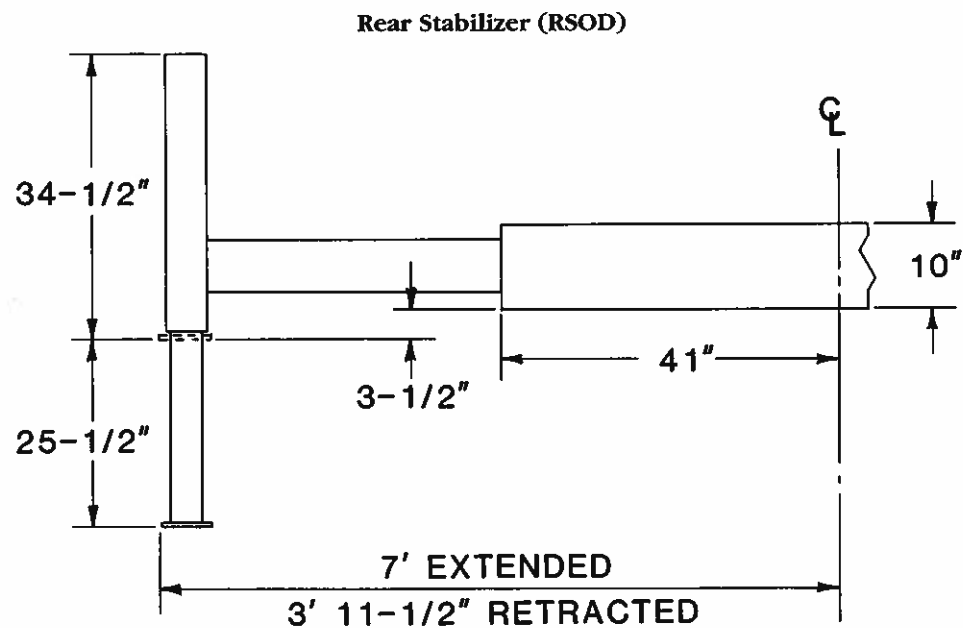

# National Boom Rests

Cranes are tough when they're in use, but they can be severely damaged during travel from job to job. The only way a crane can be protected from this type of wear and damage is a strong, solid boom rest.

## Boom Rests

- Add years to the life of your crane
- Reduce stress on the crane frame
- Protect rotation gear from transit damage
- Remove stress from truck frame
- Spread crane load more evenly
- Reduce maintenance and downtime

In addition, boom rests are required to provide a positive way to immobilize your crane for transit.

National Crane supplies two heavy-duty boom rests for strong, sure protection of your crane. There is a quality National boom rest to fit your mounting configuration. All National Cranes must be fitted with a boom rest. All factory mounted cranes will be supplied with a boom rest.

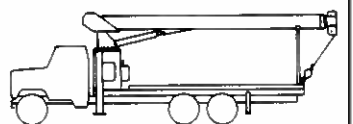

Horizontal rear bed mount for greater load space

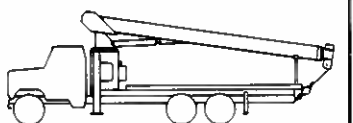

Low-profile rear bed mount for lower center of gravity

## DIMENSIONAL SPECIFICATION

MOUNTINGS	SERIES	RETRACTED LENGTH	EXTENDED LENGTH	G	DRY* WT/LB	WITH OIL* WT/LB
STANDARD MOUNT	1195	28 FT	95 FT	98°	20,800*	21,600*
REAR MOUNT	1195	28 FT	95 FT	117°	24,350**	25,150**

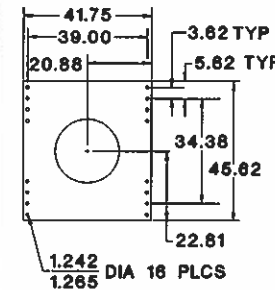

\* WEIGHT INCLUDES ALL ITEMS EXCEPT RSOD (1400#). BOOM FULLY RETRACTED.

\*\* WEIGHT INCLUDES ALL ITEMS INCLUDING COMPLETE HO OUTRIGGERS AND SRO. BOOM FULLY RETRACTED.

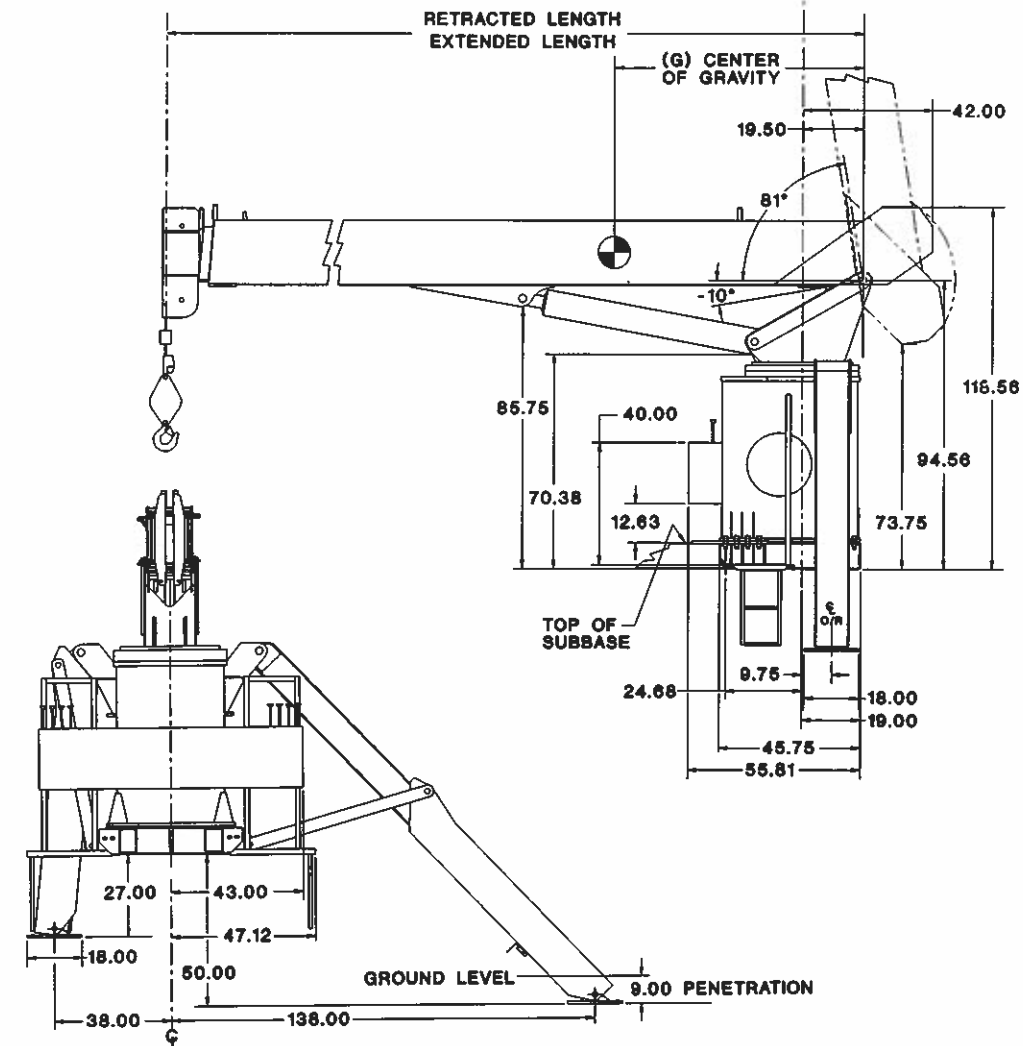
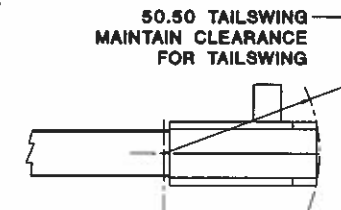

# National Series 1100 Proposal

Date: _____	Description	Price
Prepared for: _____	1. Series _____	\$ _____
_____	2. Boom _____	_____
_____	3. Jib _____	_____
Submitted by: _____	4. Rear Stabilizers: <input type="checkbox"/> RSOD <input type="checkbox"/> HO	_____
_____	5. Front Stabilizers: <input type="checkbox"/> SFO	_____
(Firm Name) _____	6. Line Block: <input type="checkbox"/> 2-3 Part <input type="checkbox"/> 4 Part <input type="checkbox"/> 5 Part <input type="checkbox"/> 6 Part <input type="checkbox"/> 7 Part	_____
(Address) _____	Accessories	_____
_____	7. _____	_____
(City & State) _____	8. _____	_____
(Zip) _____	9. _____	_____
(Phone) _____	10. _____	_____
Signed: _____	Mounting	_____
_____	11. Installation: Behind Cab <input type="checkbox"/> Std. <input type="checkbox"/> Special	_____
_____	12. Installation: Rear Mounting (add to installation charge above)	_____
	<input type="checkbox"/> Air Throttle	_____
	<input type="checkbox"/> Rear Mounting Hydraulic Group	_____
	<input type="checkbox"/> Heavy-duty Rear Mount Subbase	_____
	13. Frame Reinforcement: <input type="checkbox"/> Weld <input type="checkbox"/> Bolt Extra	_____
	14. Platform Body _____ ft. <input type="checkbox"/> Wood <input type="checkbox"/> Steel	_____
	15. Weight in bed _____ lbs. (if required)	_____
	16. Boom Rest: <input type="checkbox"/> Parallel <input type="checkbox"/> Low <input type="checkbox"/> Other	_____
	17. Mount SFO	_____
	18. Mount Stabilizers	_____
	19. Chassis	_____
	20. Rear Bumper Underride Protection <input type="checkbox"/> Ordered <input type="checkbox"/> Not Ordered	_____
	21. Freight	_____
	This quotation will remain firm for _____ days.	_____
	Accepted by _____	\$ _____
	(Name)	Total Price
	_____	_____
	(Firm Name)	(Date)



# National Series 1100 Telescoping Crane

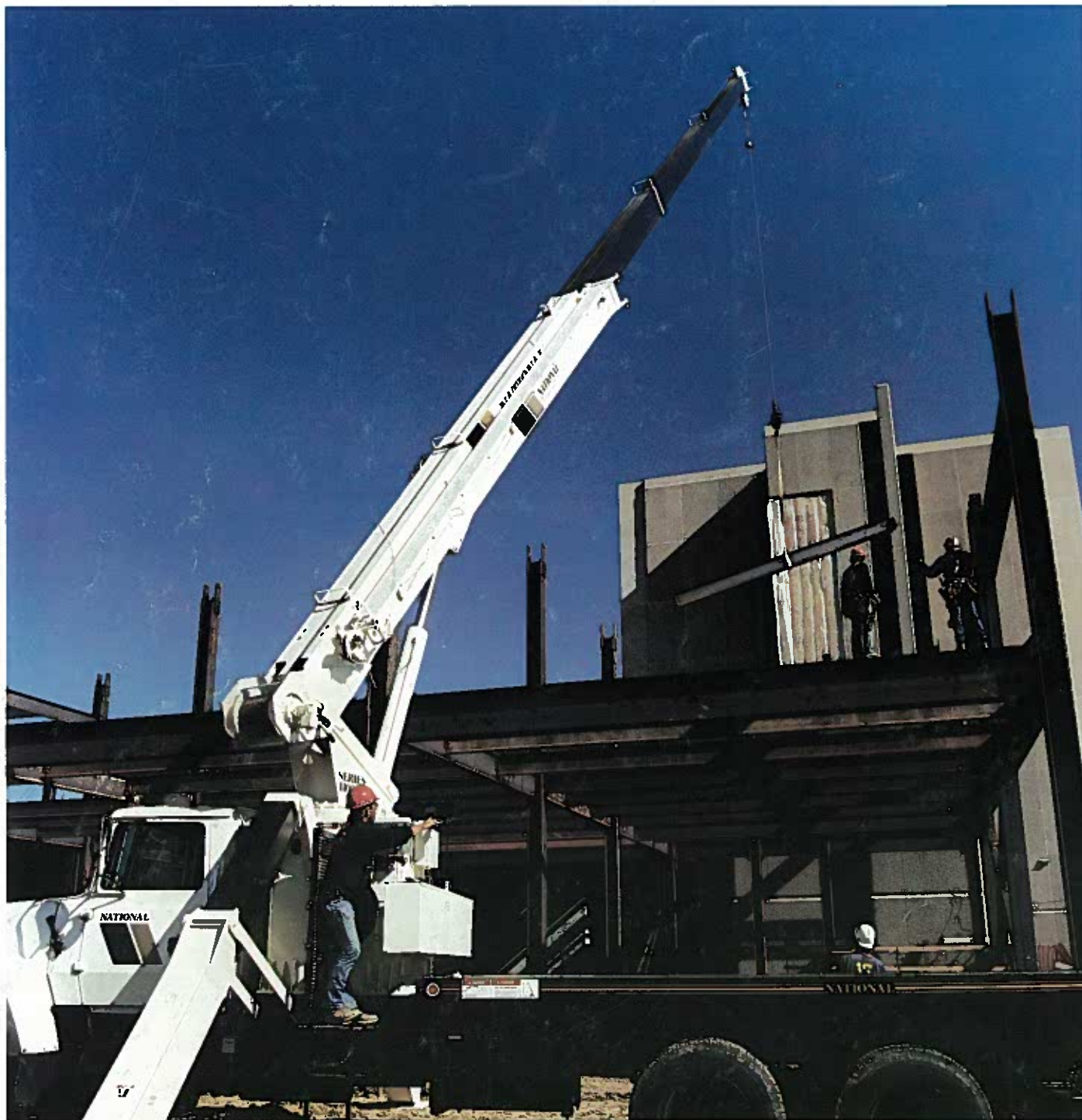

**NATIONAL CRANE**  
A Grove Worldwide Company

General Offices: 11200 North 148th Street • Waverly, NE 68462 U.S.A.  
Phone: (402) 786-6300 • FAX: (402) 786-6363

**Your National Dealer:**

National Crane reserves the right to  
change designs, prices and specifications  
at any time without notice.