

Krupp Hydraulic Truck-mounted Crane
100 GMT
120 ton Capacity



Superstructure Specifications

Boom

42'0" - 137'0" 4-section full power boom
Telescoping cycle:

1. section 65 sec.
2. section 72 sec.
3. section 47 sec.

High speed:

1. section 47 sec.
2. section 46 sec.
3. section 31 sec.

*) Jibs

38'0" swing-away lattice extension
and inserts

58'0" offsetable lattice extension
(15° and 30°)

82'0" power luffing jib

Main Hoist

Axial piston motor with planetary gear
and fail-safe brake

Single line pull max.: 16,800 lbs

Single line speed max.: 417 fpm

Drum diameter: 20"

Rope diameter: 3/4"

Rope length: 850 ft

*) Auxiliary Hoist

Axial piston motor with planetary gear
and fail-safe brake

Single line pull max.: 16,800 lbs

Single line speed max.: 417 fpm

Drum diameter: 20"

Rope diameter: 3/4"

Rope length: 850 ft

Hook Blocks

65 ton

*) 120, 35, 15 ton

and 9 ton single hook

Boom Elevation

Hydraulic cylinder with integral
holding valve, boom angle

from -1.5 to +82.0 degrees

Elevation cycle: 83 sec.

High speed: 45 sec.

Swing Gear

Axial piston motor with planetary gear,
holding and service brake,
swing speed 0 - 2.5 rpm variable

Engine

6 cyl. Daimler Benz OM 352 A

water-cooled, 139 hp at 2300 rpm

Tank capacity: 50 gal. diesel

Hydraulic system

3 separate circuits: 2 axial piston pumps
with integrated infinitely variable speed
and load control,

1 axial piston pump. *) Oil cooler.

Tank capacity: 350 gal. hydraulic oil

Control system

Infinite variation of all crane-motions by
hydraulic pilot circuit, dead-man-position

Counterweight

29,760 lbs, in 3 sections, hydraulically
removable

Operator's cab

Full vision, all steel, safety glass,
fully adjustable operator's seat
with hydraulic suspension,
independent heating and ventilation,
complete engine instrumentation
and crane operating controls.

Safety installations

Hoist limit switch, lock valves, pressure
relief valves.

*) Electronic load moment safety device
with automatic cut-out and indicators
for load moment and working radius,
lowering limit switch.

Carrier specifications

Chassis

Krupp heavy-duty 5-axle carrier, welded
box-type frame from high tensile steel

Engine

12 cyl. Daimler Benz OM 404,
water-cooled, 420 hp at 2400 rpm

Tank capacity: 150 gal.

Transmission

Allison 5 speed automatic gear-box
MAN transfer case, 2 speed with
differential lock

Axles

- | | |
|-------------------------|----------------|
| 1. driven steering axle | 4. driven axle |
| 2. steering axle | 5. driven axle |
| 3. steering axle | |
- driven axles = planetary axles
4. + 5. axle with interaxle
differential lock

Suspension

1. and 2. axle parabolic leaf springs
3. - 5. axle hydropneumatic suspension
system and axle lock-outs

Tyres

14 tyres 14.00 - 24 PR 22

4th and 5th axle dual tyres

Steering

ZF semi-integral ball-nut hydraulic
power steering

Brakes

Service brake:

pneumatic dual-circuit acting on all
wheels

Permanent brake:

retarder of Allison automatic
transmission

Auxiliary brake:

pneumatically operated spring-loaded
brake acting on 1st to 3rd axle

Driver's cab

All-steel, two-man-design with bunk,
safety glass, adjustable hydraulically
suspended seats, independent heating
and ventilation. Complete instrumen-
tation and driving controls.

Outriggers

Independent horizontal and vertical
hydraulic motion of each beam.

Control on each side of chassis.

Sight level device.

Electrical equipment

Three-phase alternator 24 V/55 A

2 batteries 12 V/180 Ah

Performance

Travelling speeds: max. 42 mph
min. 0.1 mph

Gradeability: 50%

Turning radius: 54 ft

*) Optional items

Dimensions

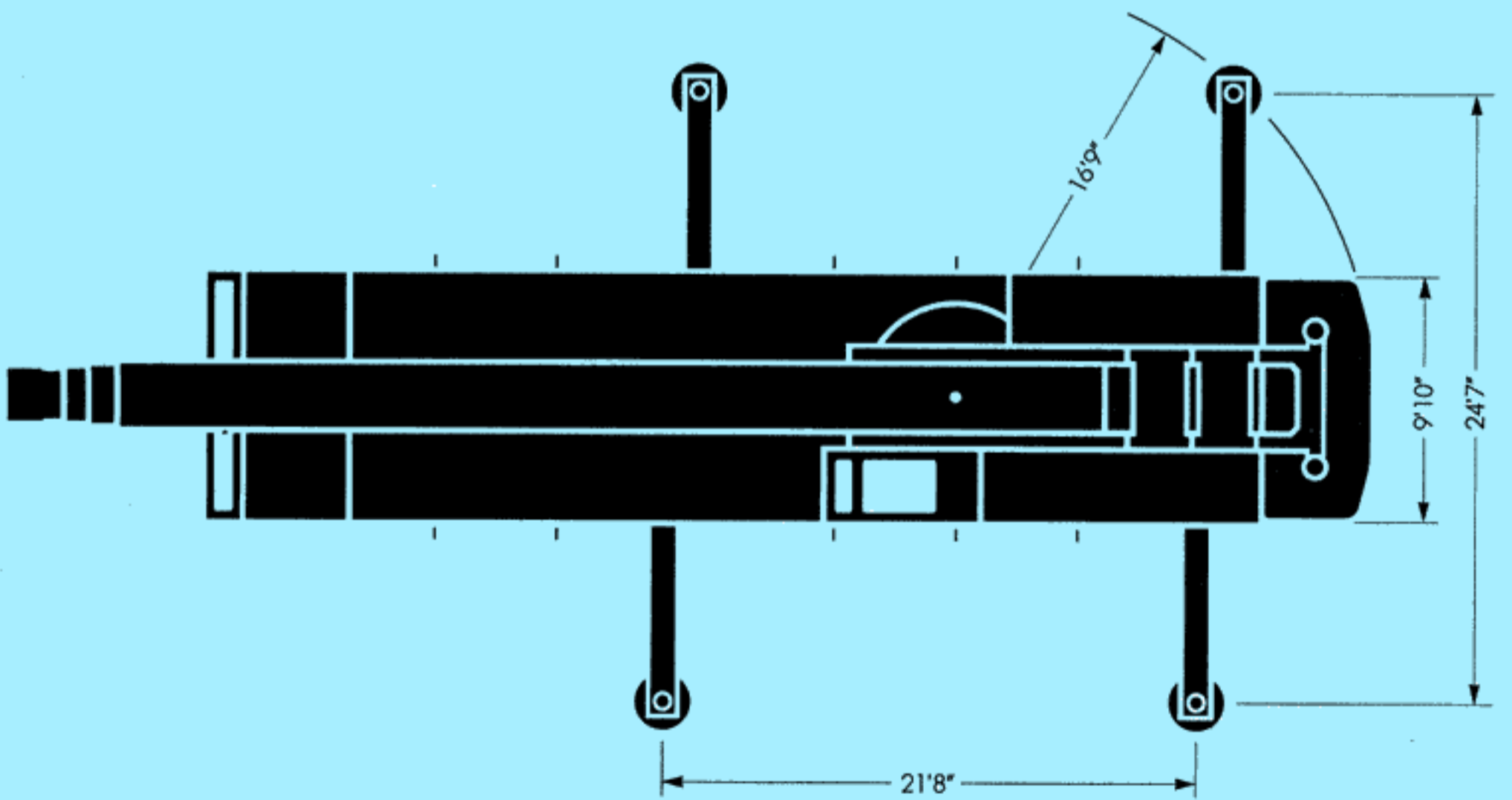
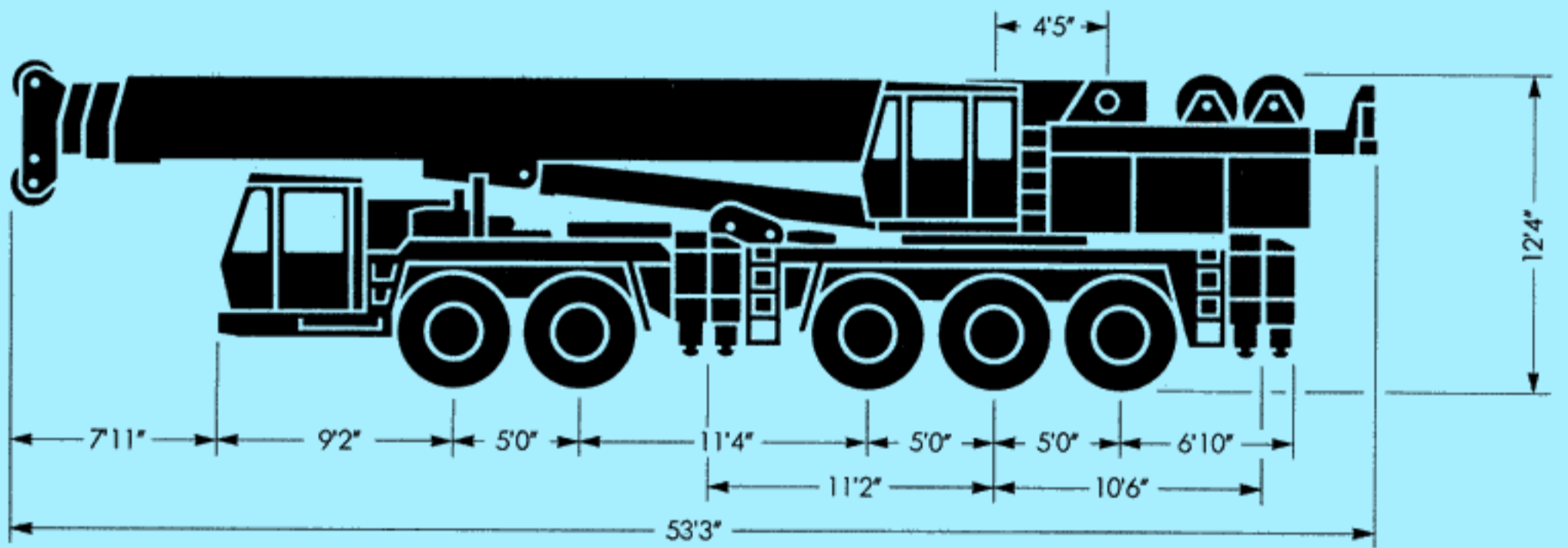

Lifting capacities in 1000 lbs

Main boom + swing-away extension

| Radius (ft) | Boom length (ft) | | | | | | | | | | | |
|----------------|---------------------------|-------|------|---------|-------|------|--------|------|--------|------|---------|--|
| | 42'0" | | | 74'0"*) | | | 105'0" | | 137'0" | | + 38'0" | |
| | Hook height max. (ft) | | | | | | | | | | | |
| | 45'0" | | | 77'0" | | | 108'0" | | 140'0" | | 178'0" | |
| | Counterweight in 1000 lbs | | | | | | | | | | | |
| | 29.7 | 7.7 | 29.7 | 29.7 | 7.7 | 29.7 | 29.7 | 7.7 | 29.7 | 7.7 | 29.7 | |
| | A | A | F | A | A | F | A | A | A | A | A | |
| 10 | 240.8 | 180.3 | | 143.3 | 132.3 | | | | | | | |
| 11 | 230.0 | 170.2 | | 143.3 | 132.3 | | | | | | | |
| 12 | 218.6 | 160.7 | | 143.3 | 132.3 | | | | | | | |
| 13 | 206.5 | 152.2 | | 143.3 | 132.3 | | | | | | | |
| 14 | 193.2 | 141.0 | | 143.3 | 127.1 | | | | | | | |
| 15 | 180.8 | 130.1 | 37.0 | 143.3 | 121.4 | 37.0 | 72.8 | 66.1 | | | | |
| 20 | 139.0 | 92.8 | 29.5 | 136.8 | 91.1 | 29.5 | 72.8 | 66.1 | 40.8 | 37.5 | | |
| 25 | 107.6 | 70.5 | 22.5 | 105.9 | 69.2 | 22.5 | 72.1 | 60.7 | 40.8 | 37.5 | | |
| 30 | 85.5 | 55.1 | 17.2 | 84.0 | 54.7 | 17.2 | 63.0 | 50.5 | 40.8 | 37.5 | 16.5 | |
| 35 | 67.2 | 43.4 | 13.2 | 67.6 | 43.2 | 13.2 | 55.0 | 42.6 | 40.8 | 35.6 | 16.5 | |
| 40 | | | | 53.3 | 33.1 | 10.2 | 48.9 | 32.9 | 39.3 | 31.5 | 16.5 | |
| 45 | | | | 43.1 | 25.5 | 7.6 | 42.5 | 25.5 | 35.1 | 27.8 | 16.0 | |
| 50 | | | | 35.4 | 20.0 | 5.0 | 35.1 | 20.1 | 30.8 | 23.2 | 15.2 | |
| 55 | | | | 29.5 | 15.6 | | 29.5 | 15.6 | 27.5 | 18.9 | 14.0 | |
| 60 | | | | 24.5 | 12.3 | | 24.9 | 12.3 | 25.1 | 15.5 | 13.1 | |
| 65 | | | | 21.0 | 9.6 | | 21.1 | 9.6 | 22.8 | 12.6 | 12.4 | |
| 70 | | | | | | | 17.7 | 7.3 | 20.5 | 10.2 | 11.5 | |
| 75 | | | | | | | 15.0 | 5.4 | 18.1 | 8.5 | 10.7 | |
| 80 | | | | | | | 12.6 | 3.8 | 16.1 | 6.8 | 10.0 | |
| 85 | | | | | | | 10.9 | 2.3 | 14.0 | 5.4 | 9.1 | |
| 90 | | | | | | | 9.1 | | 12.3 | 4.1 | 8.4 | |
| 95 | | | | | | | 7.5 | | 10.6 | 3.1 | 7.8 | |
| 100 | | | | | | | | | 9.3 | | 7.1 | |
| 105 | | | | | | | | | 7.9 | | 6.1 | |
| 110 | | | | | | | | | 6.9 | | 5.6 | |
| 115 | | | | | | | | | 5.9 | | 4.9 | |
| 120 | | | | | | | | | 4.9 | | 4.1 | |
| 125 | | | | | | | | | 3.9 | | 3.4 | |
| 130 | | | | | | | | | 3.3 | | 2.7 | |

*) 74 ft boom – section 1 and 2 equally extended

A Crane on outriggers 360°

F Crane free on wheels over rear ± 10°

Load capacities above bold line are based on structural strength, and tipping must not be relied upon as a limitation of lifting capacity.

Rated loads must not be exceeded.

Notes for lifting capacities

Rated loads do not exceed 85% of tipping load with the machine properly levelled on firm ground.

360° duties – on outriggers fully extended, other than noted above (coloured lifting range).

Note counterweight required as listed in relevant lifting capacity columns.

For safe crane operation due allowance must be made to compensate for high

winds, side load, pendulum action and other hazardous conditions. No side pull permitted.

Hook blocks, slings and/or boom attachments are considered part of the load, and their weight must be deducted from the rated lifting capacity to determine the net load.

Lattice extension (straight / off-set)

| Radius | Boom length (ft) | | |
|--------|---------------------------|--------|--------|
| | 137'0" + 57'0" = 194'0" | | |
| | Hook height max. (ft) | | |
| | 196'0" | 192'0" | 185'0" |
| | Off-set angle | | |
| | 0° | 15° | 30° |
| | Counterweight in 1000 lbs | | |
| | 29.7 | | |
| (ft) | A | | |
| 35 | 11.5 | | |
| 40 | 11.5 | | |
| 45 | 11.4 | | |
| 50 | 10.8 | | |
| 55 | 10.3 | 5.4 | |
| 60 | 9.7 | 5.3 | |
| 65 | 9.1 | 5.1 | 4.2 |
| 70 | 8.6 | 4.9 | 3.9 |
| 75 | 7.8 | 4.8 | 3.8 |
| 80 | 6.6 | 4.6 | 3.6 |
| 85 | 5.4 | 4.3 | 3.5 |
| 90 | 4.3 | 4.1 | 3.4 |
| 95 | 3.4 | 4.0 | 3.2 |
| 100 | | 3.8 | 3.1 |
| 105 | | 3.1 | 3.0 |
| 110 | | | 2.9 |

Boom must be fully extended when lifting with the 3rd (power pinned) boom section or with the swing-away extension.

Consult crane manual to determine weight reduction for load handling devices and boom attachments.

Operate crane strictly in compliance with operator's manual.

360° Power luffing jib

Counterweight 29.760 lbs

| Main boom ft | Radius ft | Jib length (ft) | | |
|-----------------|--------------|-----------------|-------|-------|
| | | 49'0" | 66'0" | 82'0" |
| 42 | 25 | 33.1 | | |
| | 30 | 32.4 | 24.4 | |
| | 35 | 26.6 | 23.9 | 16.3 |
| | 40 | 22.4 | 23.3 | 15.4 |
| | 45 | 18.6 | 19.8 | 14.5 |
| | 50 | | 17.3 | 13.8 |
| | 55 | | | 13.2 |
| | 60 | | | 12.5 |
| | 65 | | | 11.2 |
| | 70 | | | 9.8 |
| 74 | 25 | 33.1 | | |
| | 30 | 33.1 | | |
| | 35 | 30.4 | 24.2 | |
| | 40 | 25.1 | 23.8 | 16.0 |
| | 45 | 21.0 | 22.1 | 15.1 |
| | 50 | | 18.8 | 14.2 |
| | 55 | | 16.5 | 13.6 |
| | 60 | | 14.5 | 12.9 |
| | 65 | | 12.8 | 12.2 |
| | 70 | | | 10.7 |
| 105 | 35 | 30.3 | | |
| | 40 | 27.0 | 20.5 | 14.0 |
| | 45 | 23.8 | 20.0 | 13.5 |
| | 50 | 20.1 | 19.4 | 13.2 |
| | 55 | | 18.2 | 12.8 |
| | 60 | | 16.1 | 12.3 |
| | 65 | | 13.9 | 11.9 |
| | 70 | | 11.9 | 11.5 |
| | 75 | | | 10.9 |
| | 137 | 35 | 14.1 | |
| 40 | | 13.0 | 12.4 | |
| 45 | | 11.6 | 11.3 | 8.8 |
| 50 | | 10.1 | 10.0 | 8.6 |
| 55 | | 8.7 | 9.0 | 8.4 |
| 60 | | | 8.0 | 8.1 |
| 65 | | | 7.2 | 7.4 |
| 70 | | | 6.2 | 6.5 |
| 75 | | | | 5.9 |
| 80 | | | | 5.3 |
| 85 | | | 4.5 | |

Hook elevation diagram

Main boom + extension and extension (straight / off-set)

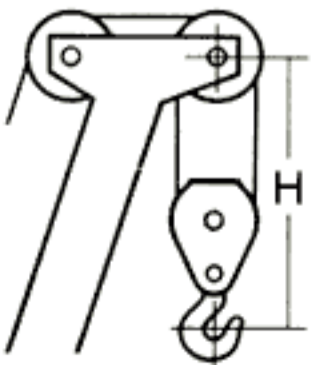
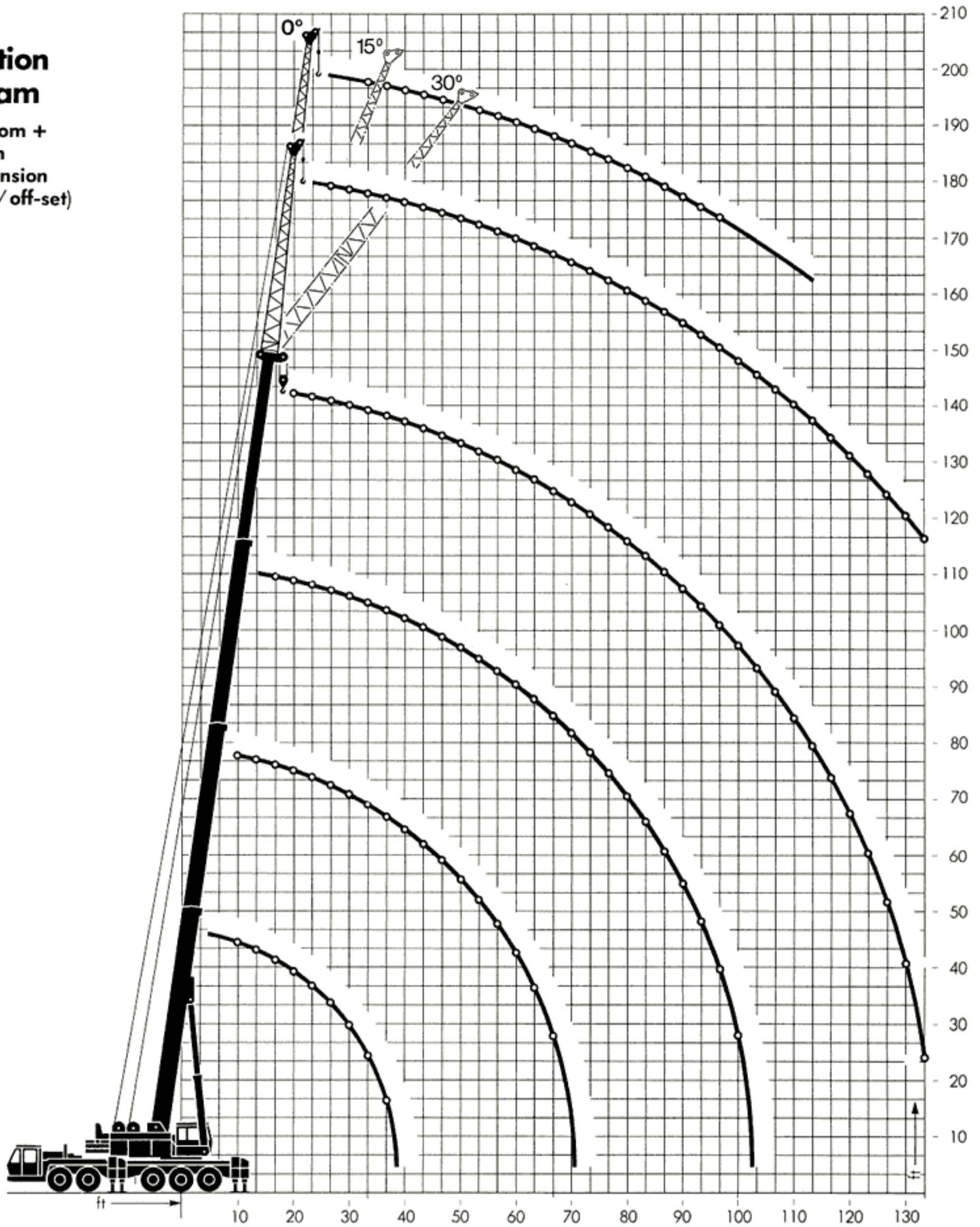

Hooks

| | | | | | | |
|------------|-----|-----|-----|------|------|-------|
| Capacity | ton | 120 | 65 | 35 | 15 | 9 |
| Sheaves | | 9 | 5 | 3 | 1 | 0 |
| Distance H | ft | 76" | 73" | 67" | 59" | 8'10" |
| Weight | ton | 1.0 | 0.9 | 0.42 | 0.31 | 0.29 |





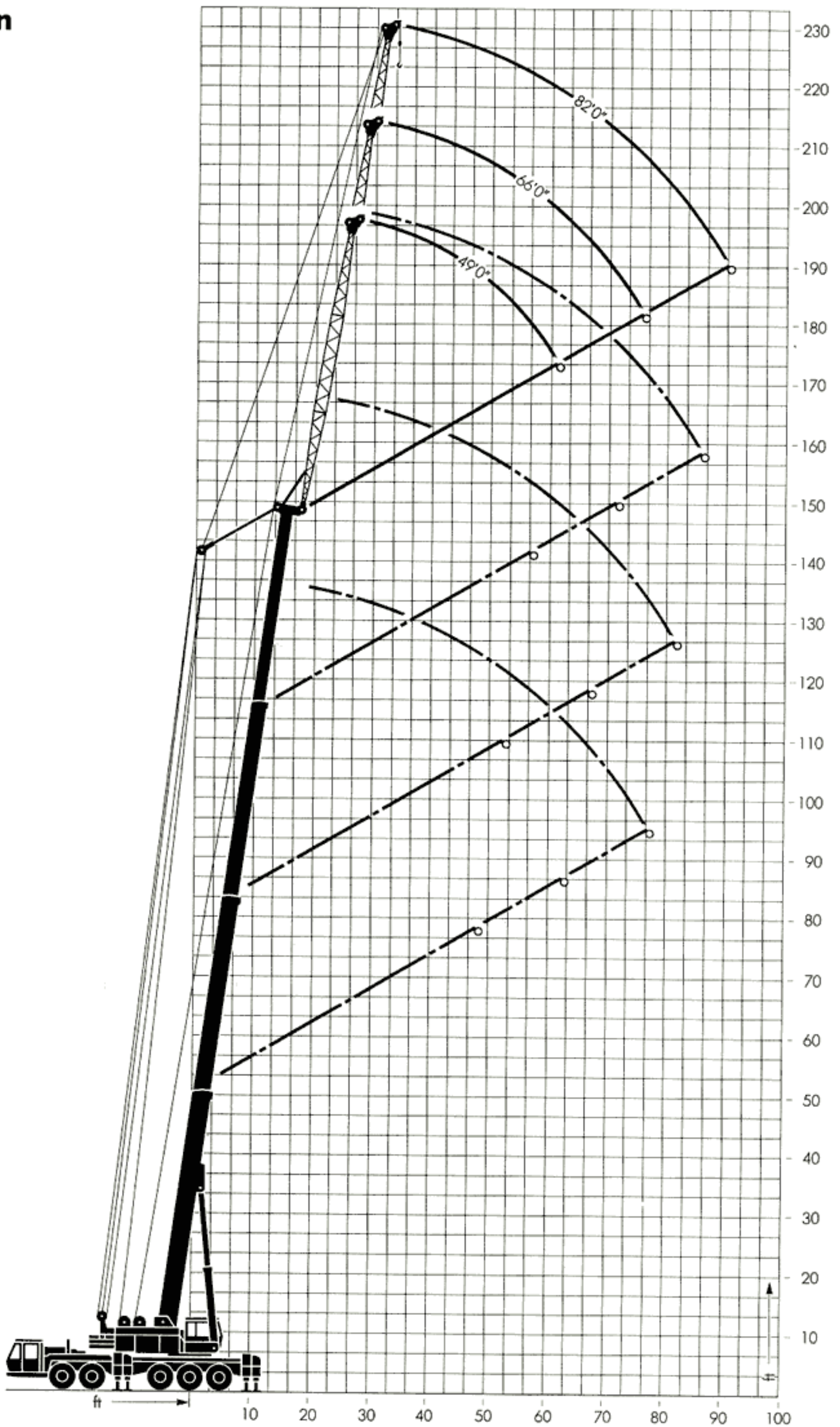



Hook elevation diagram

Power luffing jib



Krupp Hydraulic Mobile Cranes

Product Range

| Truck Cranes | | Max. lifting capacity | Max. hook height |
|---------------------------|--|-----------------------|------------------|
| 100 GMT |  | 120 ton | 220 ft* |
| 180 GMT |  | 250 ton | 320 ft* |
| 250 GMT |  | 365 ton | 345 ft* |
| 350 GMT |  | 450 ton | 365 ft* |
| 500 GMT |  | 600 ton | 430 ft* |
| All-Terrain Cranes | | | |
| 25 GMT-AT |  | 25 ton | 122 ft |
| 35 GMT-AT |  | 35 ton | 129 ft |
| 70 GMT-AT |  | 80 ton | 178 ft |
| 140 GMT-AT |  | 165 ton | 296 ft* |

* incl. power luffing jib



KRUPP INDUSTRIES, INC.
CONSTRUCTION EQUIPMENT GROUP

MAIN OFFICE
210 Vandale Drive
(Pittsburgh) Houston, PA 15342
Telephone: 412-746-9360
Telefax: 412-746-9350

BRANCH OFFICE
240 N. Norwood
Houston, Texas 77011
Telephone: 713-926-1100
Telefax: 713-926-0989

Subject to technical modifications without notice