

# Manitowoc

## MLC165/MLC165-1

### Luffing Jib Operator Manual

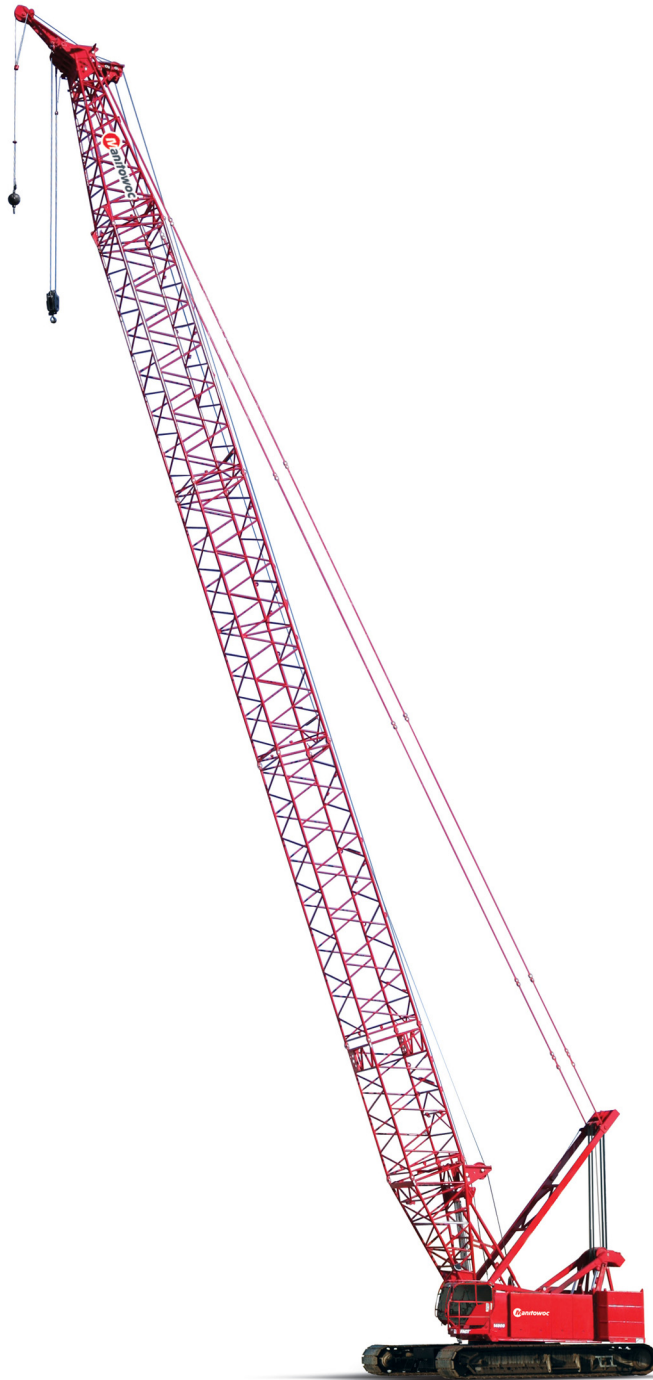

Grove

Manitowoc

National Crane

Potain







# OPERATOR MANUAL

This manual has been prepared for and is considered part of:

**MLC165/MLC165-1**

Luffing Jib Model Number

**XXXXXRef**

Luffing Jib Serial Number

This manual is divided into the following sections:



<b>SECTION 1</b>	<b>INTRODUCTION</b>
<b>SECTION 2</b>	<b>SAFETY INFORMATION</b>
<b>SECTION 3</b>	<b>OPERATING CONTROLS AND PROCEDURES</b>
<b>SECTION 4</b>	<b>SETUP AND INSTALLATION</b>
<b>SECTION 5</b>	<b>LUBRICATION</b>
<b>SECTION 6</b>	<b>MAINTENANCE PROCEDURES</b>

## NOTICE

The serial number of the crane and applicable attachments (for example, a luffing jib or MAX-ER®) is the only method a Manitowoc dealer or the Manitowoc Crane Care Lattice Team has of providing the correct parts and service information.

The serial number is located on a crane identification plate attached to the operator cab and each attachment. Refer to the Nameplate and Decal Assembly Drawing in Section 2 of this manual for the exact location of the crane identification plate.

**Always furnish serial number of crane and its attachments** when ordering parts or discussing service problems with a Manitowoc dealer or the Manitowoc Crane Care Lattice Team.

	 <b>WARNING</b>
	<p><b>To prevent death or serious injury:</b></p> <ul style="list-style-type: none"><li>• Avoid unsafe operation and maintenance.</li><li>• Crane and attachments must be operated and maintained by trained and experienced personnel. Manitowoc is not responsible for qualifying these personnel.</li><li>• Do not operate or work on crane or attachments without first reading and understanding instructions contained in the manuals supplied with crane and applicable attachments.</li><li>• Store crane manuals in the operator cab.</li><li>• If crane manuals are missing from the cab, contact a Manitowoc dealer for new ones.</li></ul>

***THE ORIGINAL LANGUAGE OF THIS PUBLICATION IS ENGLISH***



See end of this manual for Alphabetical Index

<b>SECTION 1</b> .....	<b>Introduction</b>	
Crane Data .....		1-1
Crane Weights .....		1-1
Crane/Attachment Identification .....		1-1
Change of Ownership Registration .....		1-1
Manitowoc Dealer .....		1-1
Crane Orientation .....		1-1
Identification and Location of Components .....		1-3
English and Metric Conversions .....		1-4
Direct Conversion .....		1-4
Inverse Conversion .....		1-4
<b>SECTION 2</b> .....	<b>Safety Information</b>	
Safety .....		2-1
<b>SECTION 3</b> .....	<b>Operating Controls And Procedures</b>	
Standard Hand Signals for Controlling Crane Operations .....		3-2
General Operation .....		3-6
Luffing Jib Operating Controls .....		3-6
1 – RCL/RCI Display .....		3-6
2a – Main Display - Information Screen .....		3-6
2b – Main Display—Fault Screens .....		3-7
3 – Limit Bypass Switch .....		3-9
4 – Boom Hoist Park Switch (Drum 4) .....		3-9
5a – Luffing Hoist Park Switch (Drum 3) .....		3-9
5b – Luffing Hoist Park Switch (Drum 1) .....		3-9
6 – Luffing Hoist Control .....		3-9
7 – Boom Hoist Control .....		3-9
8 – Mechanical Boom Angle Indicator .....		3-9
9 – Mechanical Crane Level .....		3-9
10 – Wind Speed Transmitter .....		3-10
11 – Position Light .....		3-10
Operating Precautions .....		3-10
Leaving Crane Unattended .....		3-10
Wind Conditions .....		3-10
<b>SECTION 4</b> .....	<b>Setup And Installation</b>	
General Setup and Installation .....		4-1
Crane Orientation .....		4-1
Accessing Parts .....		4-2
Crane Weights .....		4-2
Shipping Data .....		4-2
Operating Controls .....		4-2
Counterweight Requirement .....		4-2
Blocked Crawlers .....		4-2
Jib Assembly Drawings .....		4-2
Luffing Jib Raising Procedure .....		4-2
Identifying Jib Components .....		4-2
Handling Components .....		4-2
Retaining Connecting Pins .....		4-2
Pin and Connecting Hole Cleanliness .....		4-3
Cable Cleanliness .....		4-3
Connecting/Disconnecting Electric Cables .....		4-3
Assist Crane Requirements .....		4-3
Shipping Crane Components .....		4-5
Preparing Crane for Luffing Jib .....		4-7

Lower Boom . . . . .	4-7
Prepare Boom for Jib . . . . .	4-7
Installing Luffing Jib . . . . .	4-9
Install Jib Stop Strut Assembly . . . . .	4-9
Install Jib Butt . . . . .	4-9
Install Jib Inserts and Top . . . . .	4-11
Connect Jib Stop Control Cable . . . . .	4-11
Install Main Strut . . . . .	4-13
Install Jib Pendants . . . . .	4-13
Install Backstay Pendants . . . . .	4-13
Install Luffing Hoist Wire Rope . . . . .	4-15
Raise Main Strut and Connect Backstay Pendants . . . . .	4-17
Connect Jib Pendants to Jib Strut . . . . .	4-19
Install Jib Load Line . . . . .	4-20
Connect Electric Cords and Adjust Electronic Devices . . . . .	4-20
Pre-Raising Checks . . . . .	4-21
Raising Boom and Jib . . . . .	4-23
Preliminary Raising Procedure . . . . .	4-23
Raising Procedure . . . . .	4-25
Lowering Boom and Jib . . . . .	4-27
Lowering Procedure . . . . .	4-27
Final Lowering Procedure . . . . .	4-28
Lowering Jib Strut and Main Strut . . . . .	4-28
Removing Jib . . . . .	4-29
Wire Rope Installation . . . . .	4-30
Wire Rope Storage . . . . .	4-30
Removing Wire Rope from Shipping Reel . . . . .	4-30
Seizing and Cutting Wire Rope . . . . .	4-30
Anchoring Wire Rope to Drum . . . . .	4-31
Winding Wire Rope onto Drum . . . . .	4-32
Anchoring Wire Rope to Wedge Socket . . . . .	4-35
Anchoring Wire Rope to Button Socket . . . . .	4-35
Breaking in Wire Rope . . . . .	4-37
Pad Eye Usage for Wire Rope Reeving . . . . .	4-37
General . . . . .	4-37
Safety . . . . .	4-37
Load Line Reeving . . . . .	4-39
Load Block Identification . . . . .	4-39
Wire Rope Specifications . . . . .	4-39
Wire Rope Installation . . . . .	4-39
Dead End Locations . . . . .	4-39
Guide Sheaves and Drums . . . . .	4-39
Load Block Reeving . . . . .	4-39

**SECTION 5 . . . . . Lubrication**

Lubrication . . . . .	5-1
Lube and Coolant Product Guide . . . . .	5-1

**SECTION 6 . . . . . Maintenance Procedures**

General Maintenance . . . . .	6-1
Boom and Luffing Jib Angle Indicator . . . . .	6-1
Automatic Boom Stop . . . . .	6-3
Automatic Boom Stop Maintenance . . . . .	6-3
Automatic Boom Stop Adjustment . . . . .	6-5
Automatic Boom Stop Actuator Rod Replacement . . . . .	6-5
Physical Boom Stop . . . . .	6-7
Physical Boom Stop Angles . . . . .	6-7

Physical Boom Stop Operation .....6-7  
Physical Boom Stop Adjustment .....6-7  
Jib Stop .....6-9  
    Jib Stop Angles .....6-9  
    Jib Stop Maintenance .....6-9  
    Jib Stop Pre-Erection Checks .....6-9  
    Jib Stop Operational Checks .....6-9  
    Jib Stop Actuator Rod Replacement .....6-10  
Block-Up Limit .....6-13  
    Block-Up Limit Operation .....6-13  
    Disconnecting Block-Up Limit Switches .....6-15  
    Disconnecting Wind Speed Controller .....6-15  
    Removing Luffing Jib .....6-15  
    Block-Up Limit Maintenance .....6-17  
    Block-Up Limit Adjustment .....6-17

Reference Only

*THIS PAGE INTENTIONALLY LEFT BLANK*

# SECTION 1 INTRODUCTION

## TABLE OF CONTENTS

Crane Data .....	1-1
Crane Weights .....	1-1
Crane/Attachment Identification .....	1-1
Change of Ownership Registration .....	1-1
Manitowoc Dealer .....	1-1
Crane Orientation .....	1-1
Identification and Location of Components .....	1-3
English and Metric Conversions .....	1-4
Direct Conversion .....	1-4
Inverse Conversion .....	1-4

Reference Only

*THIS PAGE INTENTIONALLY LEFT BLANK*

## SECTION 1 INTRODUCTION

### CRANE DATA

See the end of this section for crane data specific to your crane:

- Basic Specifications
- EC Declaration (if applicable)

### CRANE WEIGHTS

See the end of this section for crane and luffing jib weights.

### CRANE/ATTACHMENT IDENTIFICATION

An identification plate is attached to the outside of the operator cab (see [Figure 1-1](#)) and to the attachments (i.e. luffing jibs) available for this crane.

The crane or attachment model and serial number are etched into the plate.

For the exact location of the identification plates on your crane and attachments, refer to the Nameplates and Decals Drawing in Section 2 of this manual.

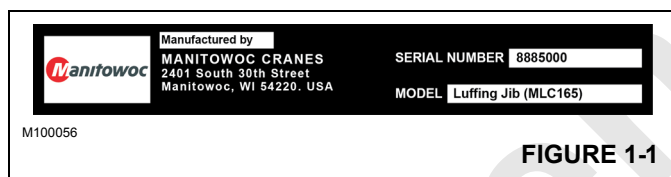

FIGURE 1-1

### CHANGE OF OWNERSHIP REGISTRATION

If you are the new owner of a Manitowoc crane, please register it with the Manitowoc Crane Care Lattice Team so we can contact you if the need arises.

1. Go to [www.manitowoccranes.com](http://www.manitowoccranes.com)
2. Go to Service > Manitowoc Crane Care > Service Information > Change of Ownership Form.
3. Complete the form.

### MANITOWOC DEALER

For questions about this manual or the MLC165 crane, contact your Manitowoc dealer. If you do not know the contact information for your dealer, locate the Manitowoc dealer nearest you, as follows:

1. Go to [www.manitowoccranes.com](http://www.manitowoccranes.com)
2. Go to Dealer Locator.
3. Follow the on-screen prompts to locate your Manitowoc dealer.

### CRANE ORIENTATION

The terms RIGHT, LEFT, FRONT, and REAR used in this manual refer to the operator's right, left, front, and rear sides when seated in the operator cab ([Figure 1-2](#)).

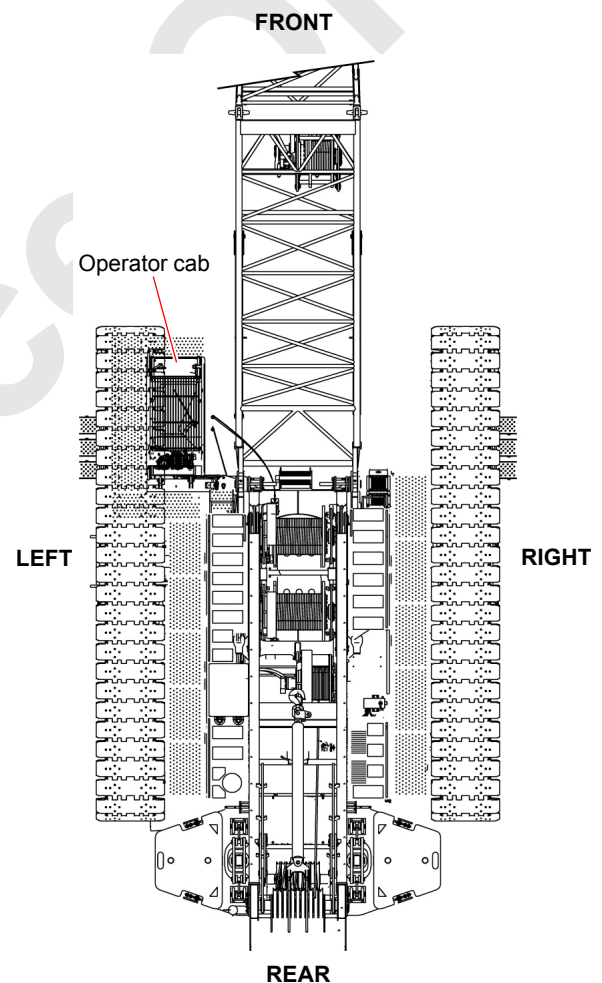

M100057

FIGURE 1-2

*THIS PAGE INTENTIONALLY LEFT BLANK*

Reference Only



IDENTIFICATION AND LOCATION OF COMPONENTS

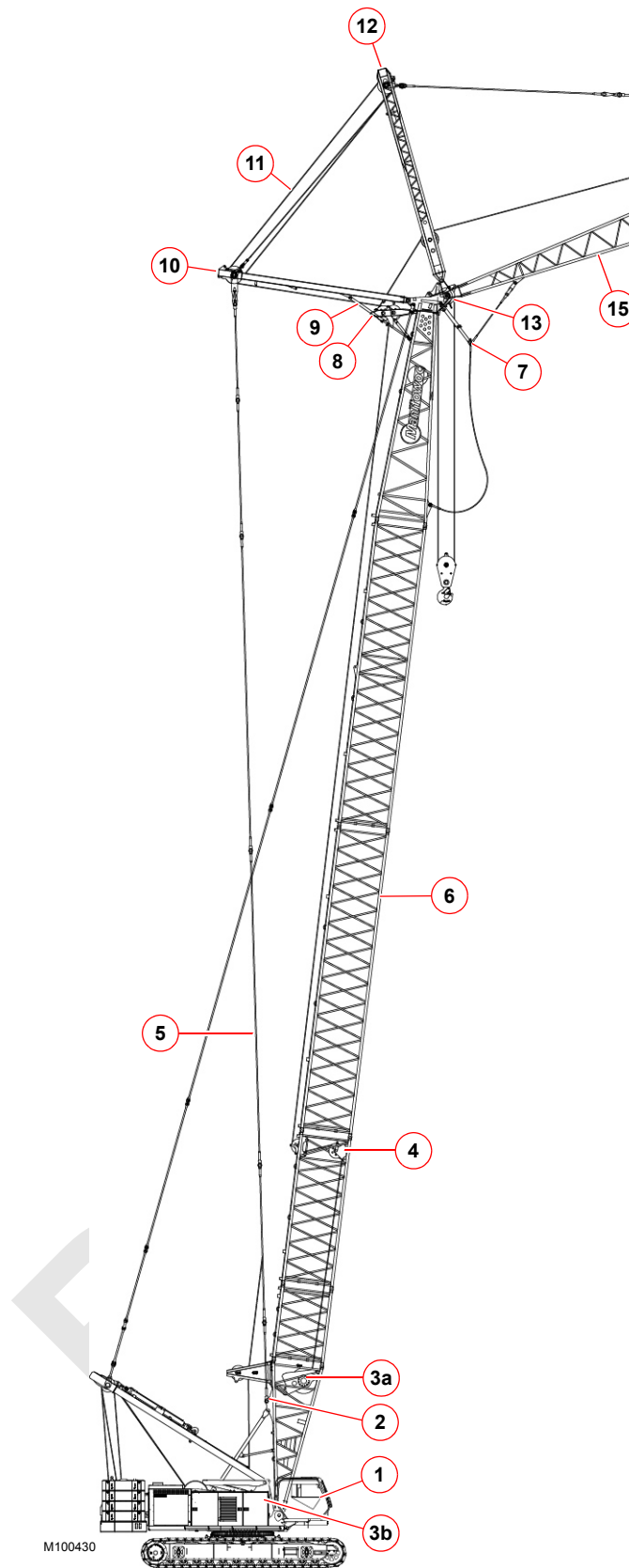

Item	Description
1	MLC165 Crane
2	Backstay Pendant Lug (2)
3a	Luffing Hoist or Auxiliary Load Drum (Optional)
3b	Front Load Drum or Luffing Hoist
4	Wire Rope Guides (Luffing Hoist)
5	Backstay Pendants
6	#74 Boom
7	Jib Stop (Physical)
8	Wire Rope Guide (Boom Top)
9	Main Strut Stops
10	Main Strut
11	Luffing Hoist Wire Rope
12	Jib Strut
13	Lower Boom Point
14	Jib Pendants
15	Jib Butt
16	Jib Inserts
17	Jib Top
18	Wire Rope Guide
19	Jib Stop Winch
20	Jib Point with Roller
21	Load Block (1 or 2 Sheaves)
22	Hook and Weight Ball

**NOTE** See MLC165 Crane Operator Manual for identification of crane and boom components.

FIGURE 1-3

## ENGLISH AND METRIC CONVERSIONS

## Inverse Conversion

## Direct Conversion

MULTIPLY (x) known value by conversion factor to obtain equivalent value in desired units. For example, 12 ft is converted to meters (m) as follows:

$$12 \text{ ft} \times 0.3048 = 3,6576 \text{ m}$$

DIVIDE (÷) known value by conversion factor to obtain equivalent value in desired units. For example, 3,6576 m is converted to feet as follows:

$$3,6576 \text{ m} \div 0.3048 = 12$$

To Convert	Symbol	Application	To	Symbol	Multiply By
<b>AREA</b>					
Square Inch	in <sup>2</sup>	Filter Area Clutch Contact	Square Centimeter	cm <sup>2</sup>	6.4516
Square Foot	ft <sup>2</sup>	Ground Contact	Square Meter	m <sup>2</sup>	0.0929
<b>FORCE</b>					
Pound Force	lb	Pedal Effort	KiloNewton Newton	kN N	0.00445 4.4482
Pound Force	lb	Line Pull	KiloNewton	kN	0.00445
Pound Force Per Inch	lb/in.	Spring Force	Newton per millimeter	Nmm	0.1751
Pound Force Per Foot	lb/ft		Newton per meter	Nm	14.5939
<b>LENGTH</b>					
Inch	in.	Adjustments	Millimeter	mm	25.4000
Foot	ft	Outline Dimensions	Meter	m	0.3048
Mile	miles	Travel Distance	Kilometer	km	1.6093
<b>POWER</b>					
Horsepower	hp	Engine	Kilowatt	kW	0.7457
<b>PRESSURE</b>					
Pound/Sq. In.	psi	Hydraulic & Air	Bar		0.0689
<b>TEMPERATURE</b>					
Degrees Fahrenheit	°F	Oil, Air, and so on	Degrees Centigrade	°C	°F - 32 ÷ 1.8
Degrees Centigrade	°C		Degrees Fahrenheit	°F	°C x 1.8 + 32
<b>TORQUE</b>					
Inch Pound	in lb	Bolt Torque	Newton Meter	Nm	0.1129
Foot Pound	ft lb		Newton Meter	Nm	1.3558
<b>VELOCITY</b>					
Miles Per Hour	mph	Vehicle Speed	Kilometers Per Hour	km/h	1.6093
Miles Per Hour	mph	Wind Speed	Meters Per Second	m/s	0.4470
Feet Per Minute	fpm	Line Speed	Meters Per Minute	m/min	0.3048
<b>VOLUME</b>					
Cubic Yard	yd <sup>3</sup>	Bucket Capacity	Cubic Meter	m <sup>3</sup>	0.7646
Cubic Foot	ft <sup>3</sup>		Cubic Meter	m <sup>3</sup>	0.0283
Cubic Inch	in <sup>3</sup>	Pump Displacement	Cubic Centimeter	cm <sup>3</sup>	16.3871
<b>VOLUME (LIQUID)</b>					

To Convert	Symbol	Application	To	Symbol	Multiply By
Ounce	oz	Fluid Capacities	Milliliter	mL	29.5735
Pint	pt		Liter	L	0.4732
Quart	qt		Liter	L	0.9464
Gallon	gal		Liter	L	3.7854
Gallon Per Minute	gpm	Pump Flow	Liters Per Minute	L/min	3.7854
WEIGHT					
Pound	lb	Unit/Component	Kilogram	kg	0.4536
Ton (2,000 lb.)	USt	Load Ratings	Metric Ton	t	0.9072
Ton (2,000 lb.)	USt		Kilogram	kg	907.1847

*THIS PAGE INTENTIONALLY LEFT BLANK*

Reference Only

**SECTION 2  
SAFETY INFORMATION**

**TABLE OF CONTENTS**

Safety .....2-1

Reference Only

*THIS PAGE INTENTIONALLY LEFT BLANK*

## SECTION 2

### SAFETY INFORMATION

#### SAFETY

Read and become thoroughly familiar with the safety information in Section 2 of the MLC165 Crane Operator Manual.

Reference Only

*THIS PAGE INTENTIONALLY LEFT BLANK*



## SECTION 3

### OPERATING CONTROLS AND PROCEDURES

#### TABLE OF CONTENTS

Standard Hand Signals for Controlling Crane Operations .....	3-2
General Operation .....	3-6
Luffing Jib Operating Controls .....	3-6
1 – RCL/RCI Display .....	3-6
Boom Angle .....	3-6
Luffing Jib Angle .....	3-6
2a – Main Display - Information Screen .....	3-6
Boom to Luffing Jib Angle .....	3-7
Wind Speed .....	3-7
2b – Main Display—Fault Screens .....	3-7
Boom Max Up Limit .....	3-7
Block-Up Limit .....	3-7
Jib Max Up 1 Limit .....	3-7
Jib Max Up 2 Limit .....	3-7
Jib Max Down 1 Limit .....	3-8
Jib Max Down 2 Limit .....	3-8
3 – Limit Bypass Switch .....	3-9
Luffing Jib Setup Mode .....	3-9
4 – Boom Hoist Park Switch (Drum 4) .....	3-9
5a – Luffing Hoist Park Switch (Drum 3) .....	3-9
5b – Luffing Hoist Park Switch (Drum 1) .....	3-9
6 – Luffing Hoist Control .....	3-9
7 – Boom Hoist Control .....	3-9
8 – Mechanical Boom Angle Indicator .....	3-9
9 – Mechanical Crane Level .....	3-9
10 – Wind Speed Transmitter .....	3-10
11 – Position Light .....	3-10
Operating Precautions .....	3-10
Leaving Crane Unattended .....	3-10
Wind Conditions .....	3-10

*THIS PAGE INTENTIONALLY LEFT BLANK*

**SECTION 3  
OPERATING CONTROLS AND PROCEDURES**



Reference Only

*THIS SECTION STARTS ON THE NEXT PAGE*

### STANDARD HAND SIGNALS FOR CONTROLLING CRANE OPERATIONS

The following standard hand signals comply with ASME B30.5-2014.

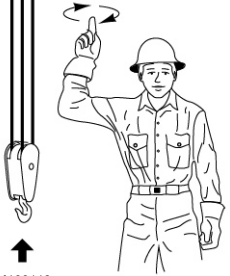
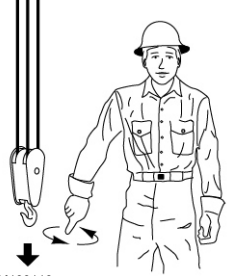
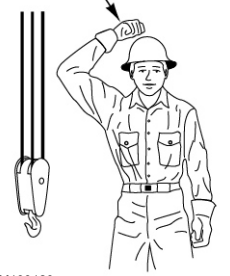
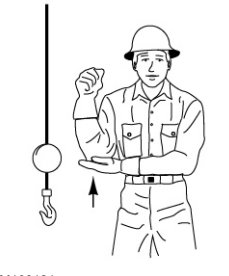
Table 3-1 Standard Hand Signals for Controlling Crane Operations

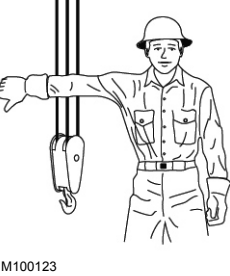
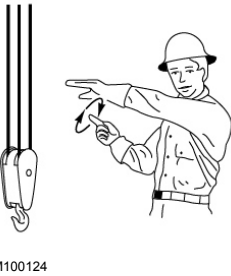
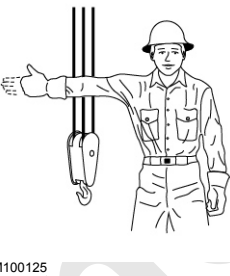
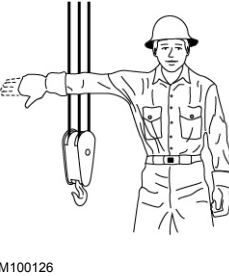
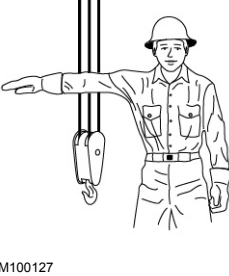
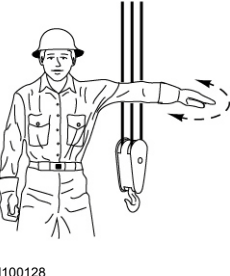
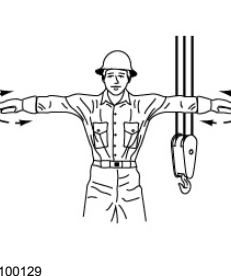
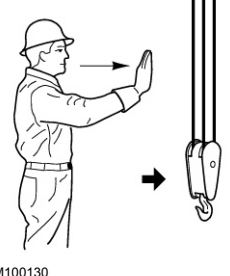
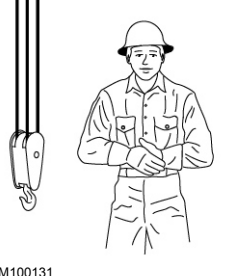
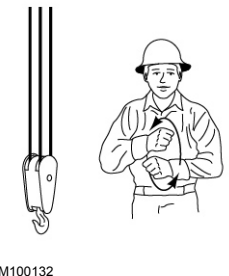
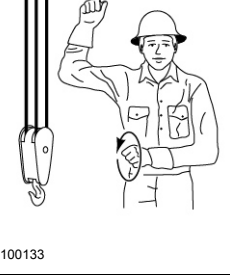
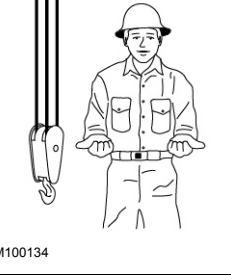
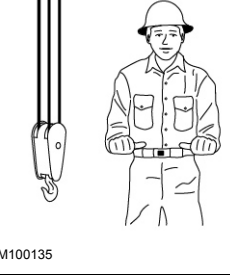
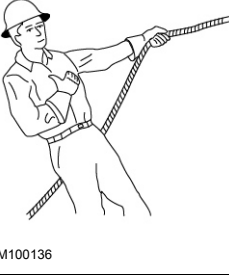
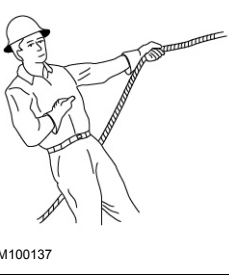
1	2	3	4	5
 <p>M100118</p>	 <p>M100119</p>	 <p>M100120</p>	 <p>M100121</p>	 <p>M100122</p>
6	7	8	9	10
 <p>M100123</p>	 <p>M100124</p>	 <p>M100125</p>	 <p>M100126</p>	 <p>M100127</p>
11	12	13	14	15
 <p>M100128</p>	 <p>M100129</p>	 <p>M100130</p>	 <p>M100131</p>	 <p>M100132</p>
16	17	18	19	20
 <p>M100133</p>	 <p>M100134</p>	 <p>M100135</p>	 <p>M100136</p>	 <p>M100137</p>

Reprinted from ASME B30.5-2014, by permission of the American Society of Mechanical Engineers. All Rights Reserved.

Item	Description
1	<b>HOIST</b> —With forearm vertical, forefinger pointing up, move hand in small horizontal circles.
2	<b>LOWER</b> —With arm extended downward, forefinger pointing down, move hand in small horizontal circles.
3	<b>USE MAIN HOIST</b> —Tap fist on head. Then use regular signals.
4	<b>USE WHIPLINE (Auxiliary Hoist)</b> —Tap elbow with one hand. Then use regular signals.
5	<b>RAISE BOOM</b> —Arm extended, fingers closed, thumb pointing upward.
6	<b>LOWER BOOM</b> —Arm extended, fingers closed, thumb pointing downward.
7	<b>MOVE SLOWLY</b> —Use one hand to give any motion signal and place other hand motionless in front of hand giving the motion signal (hoist slowly shown as an example).
8	<b>RAISE BOOM &amp; LOWER LOAD</b> —With arm extended, thumb pointing up, flex fingers in and out as long as load movement is desired.
9	<b>LOWER BOOM &amp; RAISE LOAD</b> —With arm extended, thumb pointing down, flex fingers in and out as long as load movement is desired.
10	<b>SWING</b> —Arm extended, point with finger in direction of swing of boom.
11	<b>STOP</b> —Arm extended, palm down, move arm back and forth horizontally.
12	<b>EMERGENCY STOP</b> —Both arms extended, palms down, move arms back and forth horizontally.
13	<b>TRAVEL</b> —Arm extended forward, hand open and slightly raised, make pushing motion in direction of travel.
14	<b>DOG EVERYTHING</b> —Clasp hands in front of body.
15	<b>TRAVEL (Both Tracks)</b> —Use both fists in front of body, making a circular motion about each other, indicating direction of travel forward or backward. (For Land Cranes Only).
16	<b>TRAVEL (One Track)</b> —Lock the track on side indicated by raised fist. Travel opposite track in direction indicated by circular motion of other fist, rotated vertically in front of body. (For Land Cranes Only).
17	<b>EXTEND BOOM (Telescoping Booms)</b> —Both fists in front of body with thumbs pointing outward.
18	<b>RETRACT BOOM (Telescoping Boom)</b> —Both fists in front of body with thumbs pointing toward each other.
19	<b>EXTEND BOOM (Telescoping Boom)</b> —One Hand Signal. One fist in front of chest with thumb tapping chest.
20	<b>RETRACT BOOM (Telescoping Boom)</b> —One hand signal. One fist in front of chest, thumb pointing outward and heel of fist tapping chest.

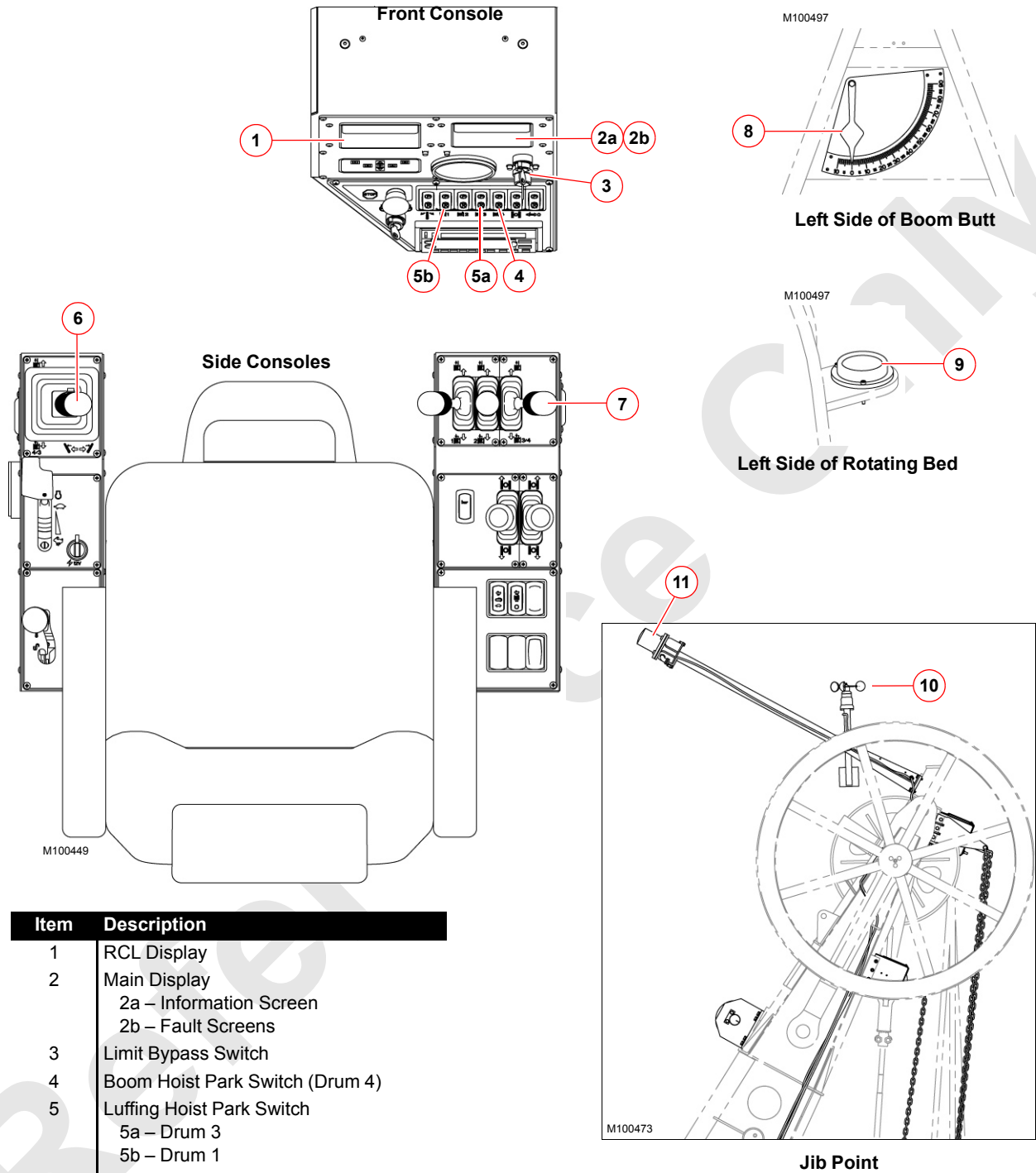

Item	Description
1	RCL Display
2	Main Display
2a	Information Screen
2b	Fault Screens
3	Limit Bypass Switch
4	Boom Hoist Park Switch (Drum 4)
5	Luffing Hoist Park Switch
5a	Drum 3
5b	Drum 1
6	Luffing Hoist Control (see <a href="#">Figure 3-2</a> )
7	Boom Hoist Control (see <a href="#">Figure 3-2</a> )
8	Mechanical Boom Angle Indicator
9	Mechanical Level
10	Wind Speed Transmitter
11	Position Light

FIGURE 3-1

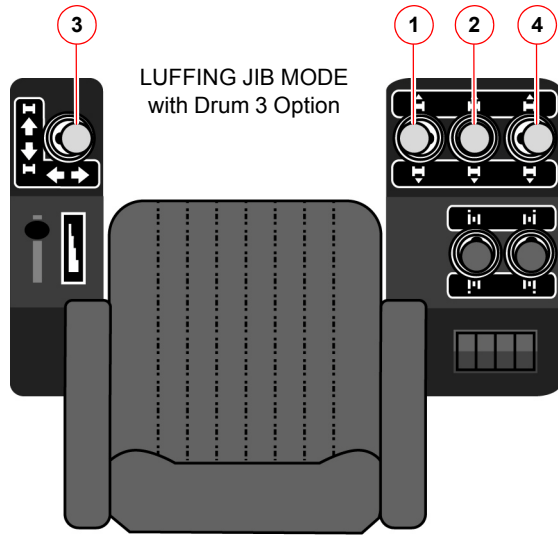

LUFFING JIB MODE with Drum 3 Option

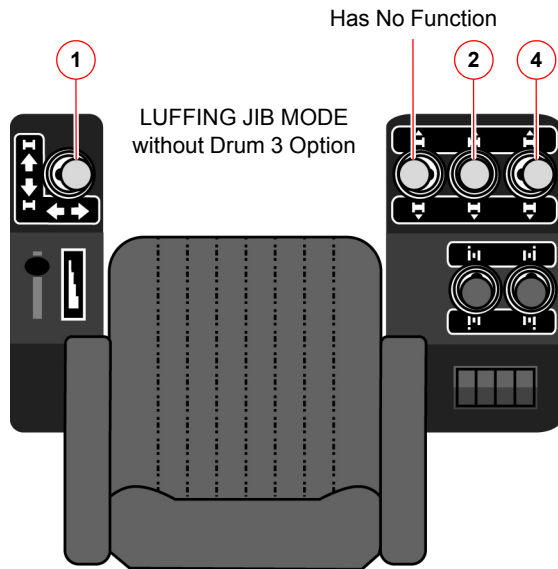

LUFFING JIB MODE without Drum 3 Option

Has No Function

M100324a

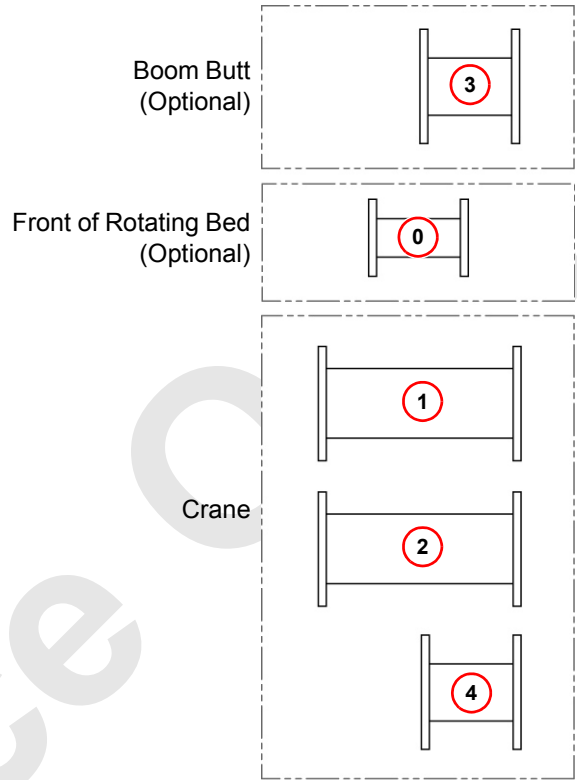

M100324b

**DRUM IDENTIFICATION**

Drum	Description
1	Front Load Drum or Luffing Hoist
2	Rear Load Drum
3	Luffing Hoist or Auxiliary Load Drum
4	Boom Hoist

**HANDLE-TO-DRUM IDENTIFICATION**

Handle	Description
1	Controls Drum 1
2	Controls Drum 2
3	Controls Drum 3
4	Controls Drum 4

**NOTE** When Drum 3 is not installed, Drum 1 is used as the luffing hoist.

When Drum 3 is installed, Drum 3 must be used as the luffing hoist.

Drum 1 cannot be used as the luffing hoist when Drum 3 is installed.

**FIGURE 3-2**

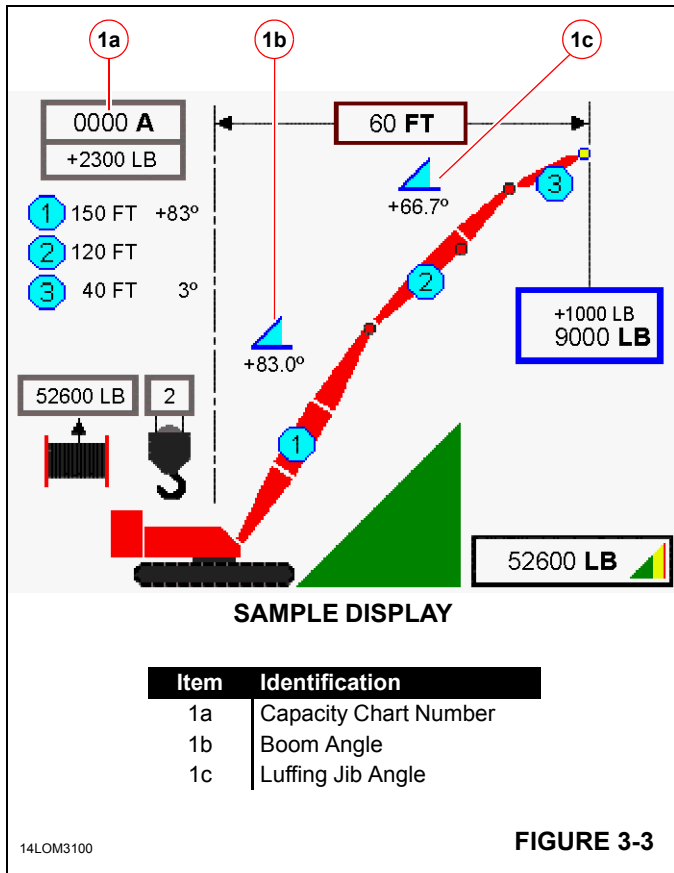

FIGURE 3-3

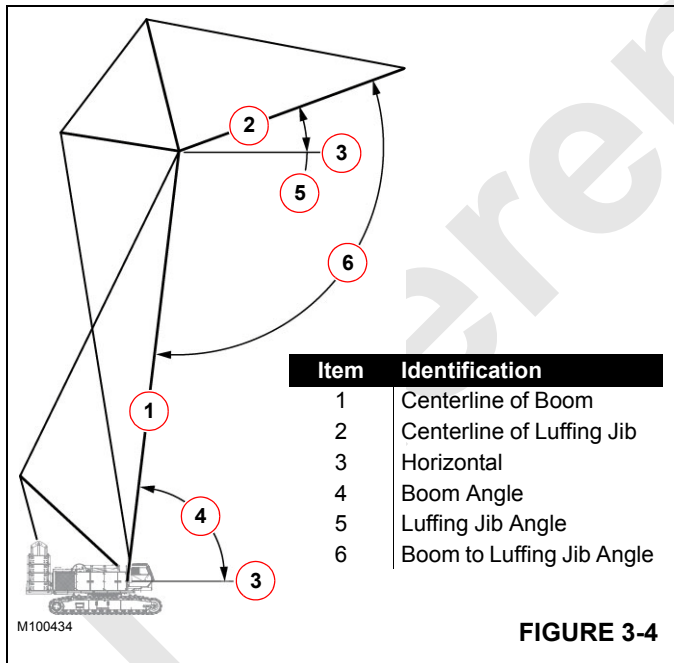

FIGURE 3-4

**GENERAL OPERATION**

The instructions in this section supplement the operating control instructions in the Crane Operator Manual. This section has two purposes:

- To familiarize qualified operators with the location of the controls used for luffing jib operation.
- To alert operators to important safety information.



**Prevent Death or Serious Injury to Personnel!**

Luffing jib attachment must be installed and operated by experienced personnel trained in erection and operation of construction cranes. These personnel shall read, understand, and comply with instructions in this manual, in the Luffing Jib Assembly Drawings, in the Liftcrane Luffing Jib Capacity Charts, and in the Crane Operator Manual.

**LUFFING JIB OPERATING CONTROLS**

See [Figure 3-1](#) on [page 3-4](#) for the location of the following controls.

**1 – RCL/RCI Display**

Read and become thoroughly familiar with the Rated Capacity Limiter/Rated Capacity Indicator Manual (F2259) provided with your crane. The manual is stored in the operator cab.

To operate in LUFFING JIB mode, operator must select the desired Liftcrane Luffing Jib Capacity Chart (Item 1a, [Figure 3-3](#)) in the RCL/RCI configuration screen.

See the Luffing Jib Operator Information Manual in the crane cab for a complete list of luffing jib capacity charts for your crane.

The RCL/RCI working screen shows all capacity related information required to operate the crane and luffing jib, to include the following:

**Boom Angle**

Item 1b, [Figure 3-3](#)

Shows the angle between the center line of boom and horizontal position (Item 4, [Figure 3-4](#)). Monitor angle when raising the boom to the operating angle.

**Luffing Jib Angle**

Item 1c, [Figure 3-3](#)

Shows the angle between the center line of the jib and horizontal (Item 5, [Figure 3-4](#)). Monitor this angle when raising and lowering the luffing jib during operation.

**2a – Main Display - Information Screen**

The main display shows information required to operate the crane and luffing jib. Read and become thoroughly familiar



with the Main Display Manual (F2260) provided with your crane. The manual is stored in the operator cab.

### Boom to Luffing Jib Angle

Shows the angle between the center line of the boom and the center line of the luffing jib (Item 6, [Figure 3-4](#)).

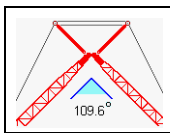

Monitor this angle when raising and lowering the boom and jib from and to the ground.

### Wind Speed

Shows the steady wind speed and the maximum gust wind speed at the luffing jib point ([Wind Conditions](#) on [page 3-10](#)).

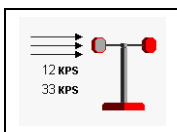

## 2b – Main Display—Fault Screens

The main display shows the following fault screens if the faults are activated during operation.



### WARNING

#### Falling Boom/Jib Hazard!

Do not raise boom above specified maximum angle. Boom and jib could be pulled over backwards.

### Boom Max Up Limit

This limit stops the boom hoist when the boom is raised to the maximum angle.

- 82.7° for boom without luffing jib
- 88.0° for boom with luffing jib



To correct the fault once it is activated, lower the boom.

The boom max up limit angle must be adjusted each time the luffing jib is installed or removed. See Section 6 in this manual for the adjustment procedure.



### WARNING

#### Two-Blocking Hazard!

If it is necessary to hoist a load above the block-up limit, do so slowly with extreme caution to prevent two-blocking.

Do not hoist load above minimum block clearance given in Range Diagram (see Capacity Chart Manual).

Do not use limit bypass switch to lower boom or luffing jib after block-up limit is contacted—two-blocking could occur, causing load to fall.

### Block-Up Limit

This limit stops the boom and luffing hoists in the down direction and the load hoists in the up direction if a load is hoisted to close to the jib point.

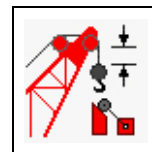

To correct the fault once it is activated, operate the boom and luffing hoists in the up direction and operate the load hoists in the down direction.

The limit bypass switch must be turned to the **bypass position** before a load can be hoisted above the limit.

### Jib Max Up 1 Limit

This limit stops the luffing jib when the boom to jib angle is 168° (max working angle).

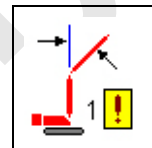

The limit bypass switch must be turned to the bypass position to allow the jib to be raised an additional 3° to the Jib Max Up 2 limit.

To correct the fault once it is activated, lower the luffing jib.



### WARNING

#### Falling Boom/Jib Hazard!

Do not raise luffing jib above Maximum Up 2 limit. Boom and luffing jib could be pulled over backwards.

Make sure luffing jib limits are enabled for normal operation (bypass switch turned counterclockwise).

### Jib Max Up 2 Limit

This limit stops the luffing jib when the boom to luffing jib angle is 171° (max angle).

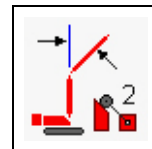

The luffing jib cannot be lowered after the Jib Max Up 2 Limit is contacted until the limit switch is reset.

When the limit is contacted, operation will stop and the jib up prompt (shown at right) will appear on the main display.

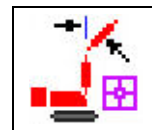

Once the prompt appears, release the control handle to off and press the confirm button (shown at right) to reset the limit switch. The luffing jib can then be lowered.



**Jib Max Down 1 Limit**

This limit turns on the fault alarm to alert the operator that the jib is near the Jib Max Down 2 Limit.

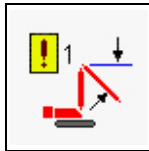

This occurs when the boom to jib angle is 60°.

To correct the fault once it is activated, raise the luffing jib.

**Jib Max Down 2 Limit**

This limit stops the luffing jib when the boom to luffing jib angle is 57°.

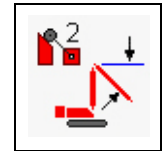

The luffing jib cannot be raised after the Jib Max Down 2 Limit is contacted until the limit switch is reset.

When the limit is contacted, operation will stop and the jib down prompt (shown at right) will appear on the main display.



Once the prompt appears, release the control handle to **off** and press the confirm button (shown at right) to reset the limit switch. The luffing jib can then be raised.



**WARNING**

**Falling Boom/Jib Hazard!**

Do not lower luffing jib below Jib Max Down 2 Limit. Structural damage will result, possibly causing boom and luffing jib to collapse.

**Table 3-2 Bypassable Limit Identification**

Limit	Limit Bypass Switch (3) (momentary key switch)		Limit Bypass Switch (3) (momentary key switch) Luffing Jib Setup Mode On <sup>1</sup>		External Override Switch <sup>2</sup>
	Non-CE	CE <sup>3</sup>	Non-CE	CE <sup>3</sup>	CE <sup>3</sup>
Boom Max Up	No	No	No	No	No
Block Up (each drum)	Yes	Yes <sup>6</sup>	Yes	Yes	No
Minimum Bail (each drum)	Yes	No	No	No	No
Jib Max Up 1	Yes	No	Yes	Yes	No
Jib Max Up 2	Yes	No	Yes <sup>4</sup>	Yes <sup>4</sup>	No
Jib Max Down 1	Yes	No	Yes	Yes	No
Jib Max Down 2	Yes <sup>5</sup>	No	Yes <sup>5</sup>	No	No
Mast Too Far Forward	No	No	No	No	No
Boom Limiter <sup>8</sup>	Yes	Yes	No	No	No
Swing Limiter <sup>8</sup>	No	No	No	No	No
Rated Capacity Indicator/Limiter	Yes	Yes <sup>6</sup>	Yes	Yes <sup>6</sup>	Yes <sup>7</sup>

<sup>1</sup> Use only for rigging. See procedure for enabling [Luffing Jib Setup Mode](#) on [page 3-9](#).

<sup>2</sup> See RCL/RCI Manual.

<sup>3</sup> CE = Cranes that comply with European requirements. Cranes meeting European requirements are equipped an RCL/RCI External Override Switch located outside the operator cab (see RCL/RCI Manual).

<sup>4</sup> Only when boom is below 50°.

<sup>5</sup> When this limit is contacted, operation will stop and you will not be able to continue lowering luffing jib. See Jib Max Down 2 on [page 3-8](#) for detailed instructions.

<sup>6</sup> Only if boom or luffing jib is below allowable angle given in Capacity Chart (while raising or lowering boom and luffing jib from or to ground level).

<sup>7</sup> When the external bypass is in override, the speed of the crane functions is limited to 25% of their maximum speed for movements that increase load.

<sup>8</sup> Cranes equipped with boom or swing motion limiter.

### 3 – Limit Bypass Switch

The Limit Bypass Switch bypasses preset limits ([Table 3-2](#)). To bypass the limits for luffing jib setup, enable the Luffing Jib Setup Mode.

#### Luffing Jib Setup Mode

1. Enter the function mode screen in the main display ([Figure 3-5](#)).

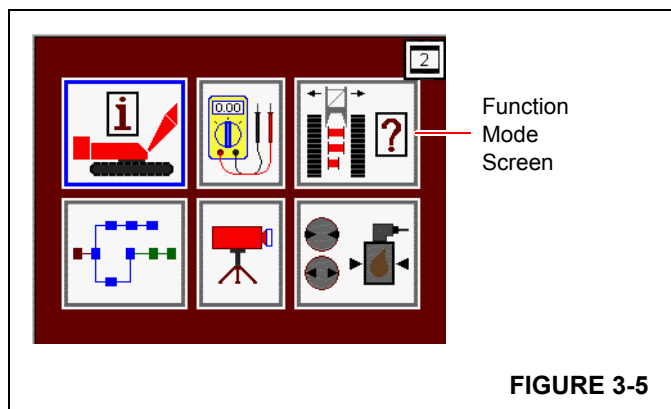

FIGURE 3-5

2. Scroll to and enter the setup mode screen ([Figure 3-6](#)).

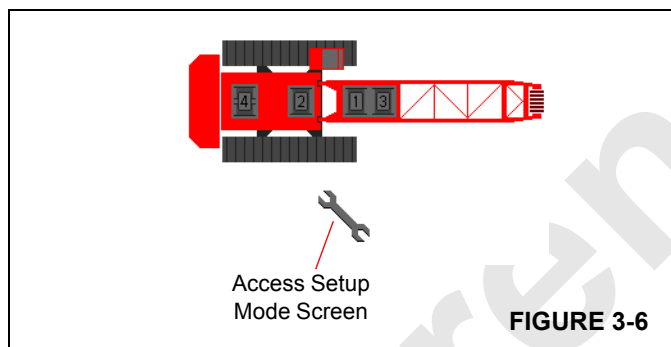

FIGURE 3-6

3. The screen shown in [Figure 3-7](#) will appear.

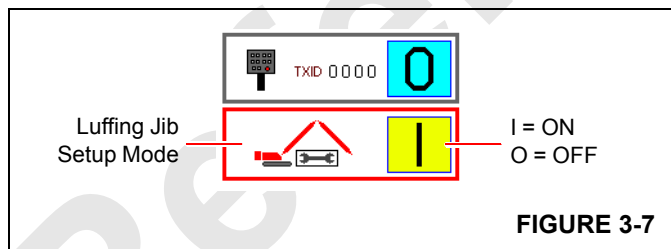

FIGURE 3-7

4. Turn the luffing jib setup mode on (or off when done with luffing jib setup).
5. Rotate limit bypass switch (3) clockwise and release it. The limits will remain bypassed for 9-10 seconds.
6. Move the desired control handle (luffing hoist, boom hoist, load drum) in the required direction. The limits will remain bypassed for as long as the handle is moved in either direction.

7. The limits will remain bypassed for 9-10 seconds after the control handle(s) is returned to off.

**NOTE** When the luffing jib setup mode is on, the crane setup fault is turned on and the alarm in the cab sounds intermittently.

### 4 – Boom Hoist Park Switch (Drum 4)

#### 5a – Luffing Hoist Park Switch (Drum 3)

#### 5b – Luffing Hoist Park Switch (Drum 1)

#### 6 – Luffing Hoist Control

#### 7 – Boom Hoist Control

See the Operating Controls in Section 3 of the Crane Operator Manual for operation of these controls.

**NOTE** Drum 3 is optional. Drum 1 is used for the luffing hoist when Drum 3 is not provided.

### 8 – Mechanical Boom Angle Indicator

Shows the angle of the boom in degrees above horizontal. The indicator is visible through the right side cab window.

The boom angle is also shown on the RCL/RCI working screen (Item 1b, [Figure 3-3](#)).

### 9 – Mechanical Crane Level

#### Figure 3-8

Shows crane levelness from front to rear and from side to side. The level is visible through the right side cab window.

### **! WARNING** Tipping Hazard!

Unless otherwise specified in the Liftcrane Luffing Jib Capacity Chart, all crane operations must be performed with crane **level** to within 1% of grade in all directions—1 ft in 100 ft (0.3 m in 30 m)—otherwise, crane could tip.

Centered bubble indicates level. One half of bubble off center indicates approximately 1/2° out of level.

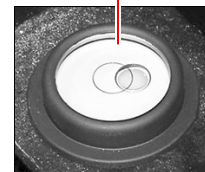

P2361

FIGURE 3-8

## 10 – Wind Speed Transmitter

### [Figure 3-1](#)

Sends wind speed information from the jib point to the main display information screen.

## 11 – Position Light

### [Figure 3-1](#)

This red strobe light shows the position of the jib point. The light is controlled by a switch in the crane cab.

## OPERATING PRECAUTIONS

- Read and comply with the instructions in the Liftcrane Luffing Jib Capacity Charts provided with your luffing jib attachment. Do not operate beyond the limits given in the capacity charts.
  - Make sure the proper counterweight is installed on the crane.
  - Read and comply with the instructions in this manual and in the Crane Operator Manual.
  - Read and comply with the Maximum Allowable Travel Specifications in the Luffing Jib Capacity Chart Manual.
  - Read and comply with the RCL/RCI Manual supplied with your crane.
  - Make sure the luffing jib attachment is installed properly. Read and comply with the instructions in Section 4.
  - Make sure all safety devices—block-up limits, boom angle indicator, boom and jib stops, RCL/RCI—are installed and operating properly.
  - Make sure the proper Liftcrane Luffing Jib Capacity Chart is selected in the RCL/RCI configuration screen.
  - Raise and lower the attachment as instructed in Section 4.
  - Perform all operations with the crane on a firm, level, uniformly supporting surface.
  - Operate all crane functions slowly and smoothly. Avoid sudden starts and stops which could side load or shock load the attachment.
- Do not operate, to include raising the boom and luffing jib from ground level, if the wind exceeds the allowable limits. Contact your local weather station for wind velocity.

## LEAVING CRANE UNATTENDED

When left unattended, the crane must be parked as instructed in Section 3 of the Crane Operator Manual.

## WIND CONDITIONS

Wind adversely affects the crane's lifting capacity and stability. The result can be loss of control over the load and crane, even if the load is within the crane's capacity.



### WARNING

#### Tipping Crane Hazard!

Judgment and experience of qualified operators, job planners, and supervisors must be used to compensate for affect of wind on lifted load and boom by reducing ratings or operating speeds, or a combination of both.

Failing to observe this precaution can cause crane to tip or boom and jib to collapse. Death or serious injury to personnel can result.

Wind speed (including wind gusts) must be monitored by job planners and supervisors.

Wind speed at the boom or jib point can be greater than wind speed at ground level. Also, be aware that the larger the sail area of the load, the greater the wind's affect on the load.

As a general rule, ratings and operating speeds must be reduced when:

**Wind causes load to swing forward past allowable operating radius or sideways past either boom hinge pin.**

For wind conditions specific to this crane, see the Wind Conditions Chart at end of this section or, if applicable, see the wind conditions in the capacity charts provided with your crane and luffing jib.

## SECTION 4

### SET-UP AND INSTALLATION

#### TABLE OF CONTENTS

General Setup and Installation . . . . .	4-1
Crane Orientation . . . . .	4-1
Accessing Parts . . . . .	4-2
Crane Weights . . . . .	4-2
Shipping Data . . . . .	4-2
Operating Controls . . . . .	4-2
Counterweight Requirement . . . . .	4-2
Blocked Crawlers . . . . .	4-2
Jib Assembly Drawings . . . . .	4-2
Luffing Jib Raising Procedure . . . . .	4-2
Identifying Jib Components . . . . .	4-2
Handling Components . . . . .	4-2
Retaining Connecting Pins . . . . .	4-2
Pin and Connecting Hole Cleanliness . . . . .	4-3
Cable Cleanliness . . . . .	4-3
Connecting/Disconnecting Electric Cables . . . . .	4-3
Assist Crane Requirements . . . . .	4-3
Shipping Crane Components . . . . .	4-5
Preparing Crane for Luffing Jib . . . . .	4-7
Lower Boom . . . . .	4-7
Prepare Boom for Jib . . . . .	4-7
Installing Luffing Jib . . . . .	4-9
Install Jib Stop Strut Assembly . . . . .	4-9
Install Jib Butt . . . . .	4-9
Install Jib Inserts and Top . . . . .	4-11
Connect Jib Stop Control Cable . . . . .	4-11
Install Main Strut . . . . .	4-13
Install Jib Pendants . . . . .	4-13
Install Backstay Pendants . . . . .	4-13
Install Luffing Hoist Wire Rope . . . . .	4-15
Raise Main Strut and Connect Backstay Pendants . . . . .	4-17
Connect Jib Pendants to Jib Strut . . . . .	4-19
Install Jib Load Line . . . . .	4-20
Connect Electric Cords and Adjust Electronic Devices . . . . .	4-20
Pre-Raising Checks . . . . .	4-21
Raising Boom and Jib . . . . .	4-23
Preliminary Raising Procedure . . . . .	4-23
Raising Procedure . . . . .	4-25
Lowering Boom and Jib . . . . .	4-27
Lowering Procedure . . . . .	4-27
Final Lowering Procedure . . . . .	4-28
Lowering Jib Strut and Main Strut . . . . .	4-28
Removing Jib . . . . .	4-29
Wire Rope Installation . . . . .	4-30
Wire Rope Storage . . . . .	4-30
Removing Wire Rope from Shipping Reel . . . . .	4-30
Seizing and Cutting Wire Rope . . . . .	4-30
Anchoring Wire Rope to Drum . . . . .	4-31
Winding Wire Rope onto Drum . . . . .	4-32
Anchoring Wire Rope to Wedge Socket . . . . .	4-35
Anchoring Wire Rope to Button Socket . . . . .	4-35

Breaking in Wire Rope . . . . .	4-37
Pad Eye Usage for Wire Rope Reeving . . . . .	4-37
General . . . . .	4-37
Safety . . . . .	4-37
Load Line Reeving . . . . .	4-39
Load Block Identification . . . . .	4-39
Wire Rope Specifications . . . . .	4-39
Wire Rope Installation . . . . .	4-39
Dead End Locations . . . . .	4-39
Guide Sheaves and Drums . . . . .	4-39
Load Block Reeving . . . . .	4-39

Reference Only

## SECTION 4

### SETUP AND INSTALLATION



#### WARNING

##### Avoid Death or Serious injury!

Read and understand instructions in this section before attempting to install or remove luffing jib.

##### Moving Parts/Pinch Points!

Avoid death or crushing injury during crane assembly and disassembly.

- Take every precaution to prevent injury when working near moving parts.
- Maintain communication between operator and assemblers to avoid accidents.

#### KEEP UNAUTHORIZED PERSONNEL WELL CLEAR OF CRANE

##### Falling Load Hazard!

To prevent lifting equipment from failing and load from dropping, crane owner/user shall verify the following prior to each lift:

- All lifting equipment (shackles, hooks, slings, blocks) has been properly maintained and is safe for use.
- All lifting equipment has a capacity equal to or greater than load to be lifted.

#### GENERAL SETUP AND INSTALLATION

This section contains installation and removal instructions for the #135 Luffing Jib on the Model MLC165 Crane.

The luffing jib must be installed, operated, and removed by experienced personnel trained in the operation and erection of construction cranes. These personnel must read, understand, and comply with the instructions in this section, in the Luffing Jib Assembly Drawing at the end of this section, and in the Liftcrane Luffing Jib Capacity Charts provided with the attachment.

Contact your Manitowoc dealer for a detailed explanation of any procedure you do not fully understand.

The installation and removal area must be firm, level, and free of ground and overhead obstructions.

*Level = 1% of grade or 1 ft (0,3 m) in 100 ft (30,5 m)*

The area selected must be large enough to accommodate the crane, the selected boom and jib lengths, and movement of an assist crane.

See the Luffing Jib Assembly Drawing at the end of this section for:

- Maximum combined boom and luffing jib length
- Minimum boom length for use with a luffing jib

#### CRANE ORIENTATION

The terms RIGHT, LEFT, FRONT, and REAR used in this section refer to the operator's right, left, front, and rear sides when seated in the operator cab looking forward.

## ACCESSING PARTS

Many parts of the crane, boom, and jib cannot be reached from the ground. Take necessary precautions to prevent falling off the crane, the boom, or the jib during installation and removal.

**Owner/user shall provide approved ladders or personnel hoists so workers can safely access those areas of crane, boom, and jib that cannot be reached from ground. Adhere to local, state, and federal regulations for handling personnel.**

Optional boom ladders (stored in boom butt) are available from Manitowoc. If your crane has ladders see Section 4 of the Crane Operator Manual for instructions.

## CRANE WEIGHTS

For component weights, refer to Section 1.

## SHIPPING DATA

For shipping data (outline dimensions and weights) refer to the MLC165 Product Guide at the end of Section 1.

## OPERATING CONTROLS

Become thoroughly familiar with the location and function of all operating controls provided for the crane and luffing jib. Read and understand the instructions in Section 3 and in Section 3 of the Crane Operator Manual.

## COUNTERWEIGHT REQUIREMENT

See the applicable Liftcrane Luffing Jib Capacity Chart for counterweight requirements when operating with the luffing jib.



### WARNING

#### Tipping Hazard!

Prevent crane from tipping. Do not operate crane until proper counterweight is installed.

## BLOCKED CRAWLERS

To prevent the crane from tipping or structural damage to the attachment, **some boom and jib combinations must be raised and lowered over blocked crawlers**. See the Liftcrane Luffing Jib Capacity Chart and Luffing Jib Raising Procedure Chart for blocked crawler requirements. Also see the Capacity Chart Information folio in the Luffing Jib Capacity Chart Manual for blocking instructions.



### DANGER

#### Tipping Hazard!

Prevent crane from tipping or structural damage to attachment. Do not attempt to raise or lower boom and jib from or to ground until crawlers are blocked.

## JIB ASSEMBLY DRAWINGS

See the Luffing Jib Assembly Drawing at the end of this section. The boom and luffing jib components (butts, inserts, tops, pendants, straps) must be assembled in proper sequence according to the drawing.

## LUFFING JIB RAISING PROCEDURE

See the Luffing Jib Raising (and Lowering) Procedure at the end of this section. The procedure contains critical raising and lowering information. **Read and thoroughly understand procedure before attempting to raise or lower boom and luffing jib.**

## IDENTIFYING JIB COMPONENTS

The jib sections are marked for proper identification ([Figure 4-1](#), View A).

The pendants are marked for proper identification ([Figure 4-1](#), View B).

## HANDLING COMPONENTS

Handle boom and jib components with care to avoid damaging lacing and chords.

**Lift against chords only, never against lacing.**

Nylon slings should be used to handle components. If wire rope or chain slings are used, protective covering (such as sections of rubber tire) must be used between the slings and the component.

## RETAINING CONNECTING PINS

Connecting pins are retained in various ways:

- Snap pins
- Quick-release pins
- Cotter pins
- Keeper plates with cap screws and lock washers

**Do not operate crane until all connecting pins are installed and properly retained.**



Item	Description
1	Boom or Jib Chord
2	Boom or Jib Number
3	Manitowoc Manufacturing Code
4	Manitowoc Part Number
5	Pendant
5a	Aluminum Tag (if equipped)
6	Manitowoc Purchase Order Number
7	Manufacturer's Number
8	Wire Rope Type
9	Diameter
10	Length

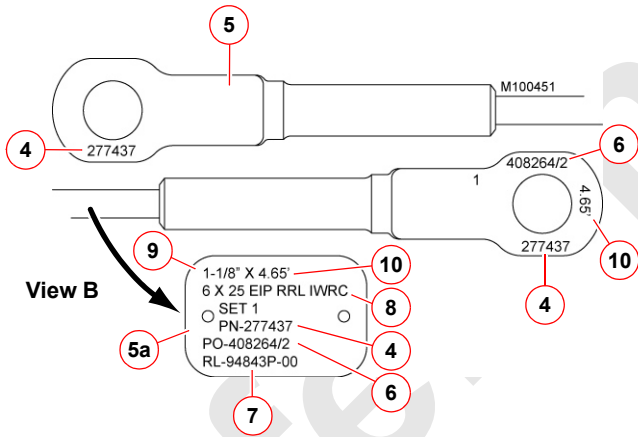
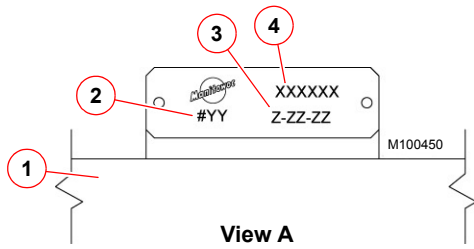

FIGURE 4-1

### PIN AND CONNECTING HOLE CLEANLINESS

To prevent dirt from damaging closely machined surfaces of pins and connecting holes:

- Thoroughly clean all pins and connecting holes.
- Apply a light coat of grease to all pins and connecting holes.

### CABLE CLEANLINESS

To prevent dirt from damaging the electric connectors:

- Thoroughly clean the electric connectors before connecting them.
- Thoroughly clean the dust caps before attaching them to cables.
- Do not drag the electric cable connectors or the electric cables on the ground.
- Apply a light coat of silicone lubricant to the threads of all dust caps, and connectors to help in preventing the threads from seizing.

### CONNECTING/DISCONNECTING ELECTRIC CABLES

Always STOP ENGINE before performing connecting and disconnecting electric cables. The potential for operating faults or damage to the electric components exists if the engine is not stopped.

### ASSIST CRANE REQUIREMENTS

An assist crane is required for jib installation and removal.

The jib butt and struts are shipped as an assembled unit. This assembly weighs approximately 9,870 lb (4 477 kg) and is the heaviest weight to be lifted. Size the assist crane accordingly.

*THIS PAGE INTENTIONALLY LEFT BLANK*

## SHIPPING CRANE COMPONENTS

It is the owner/user's responsibility to ensure:

- That all trailer loads comply with local, state, and federal transportation requirements.
- ***That all crane components are properly blocked and secured so they cannot shift or fall off trailers.***

To avoid damage to components:

- Use nylon tie-downs to secure components ([Figure 4-2, View A](#)).
- If chain tie-downs are used, install protective covering (such as sections of rubber tire) between the chain and the component being secured ([Figure 4-2, View B](#)).
- When securing boom and jib sections, wrap the tie-downs over the chords—never over the lacings. Keep the tie-downs as close to the blocking as possible (View A) to prevent bending the chords.

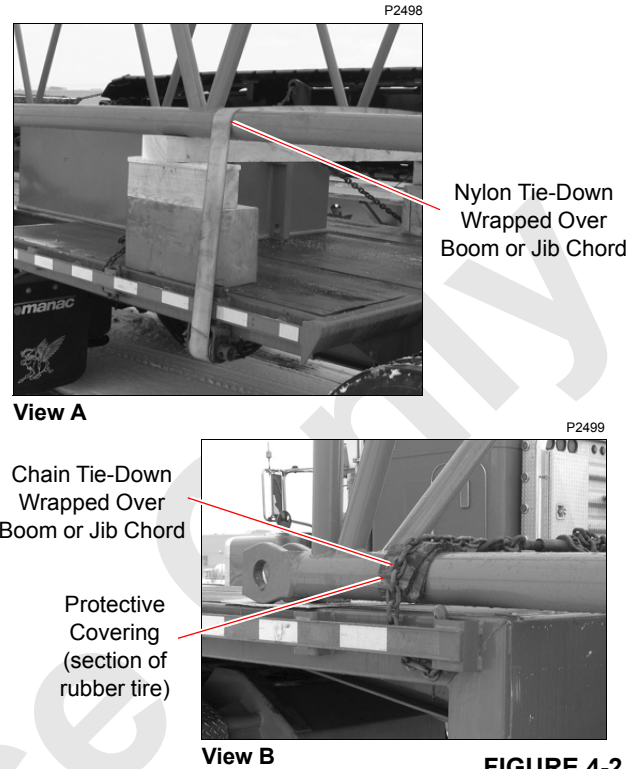

**NOTE** The Model MLC165 boom top wire rope guide shown. The Model MLC165-1 boom top wire rope guide has holes in the shafts to which the clamps are fastened.

Item	Description
1	Blocking (if required)
2	Load Block
3	Blocking
4	Sheave Clusters
5	Wire Rope Guide (Boom Top)
6	Wire Rope Guide (Boom Butt)

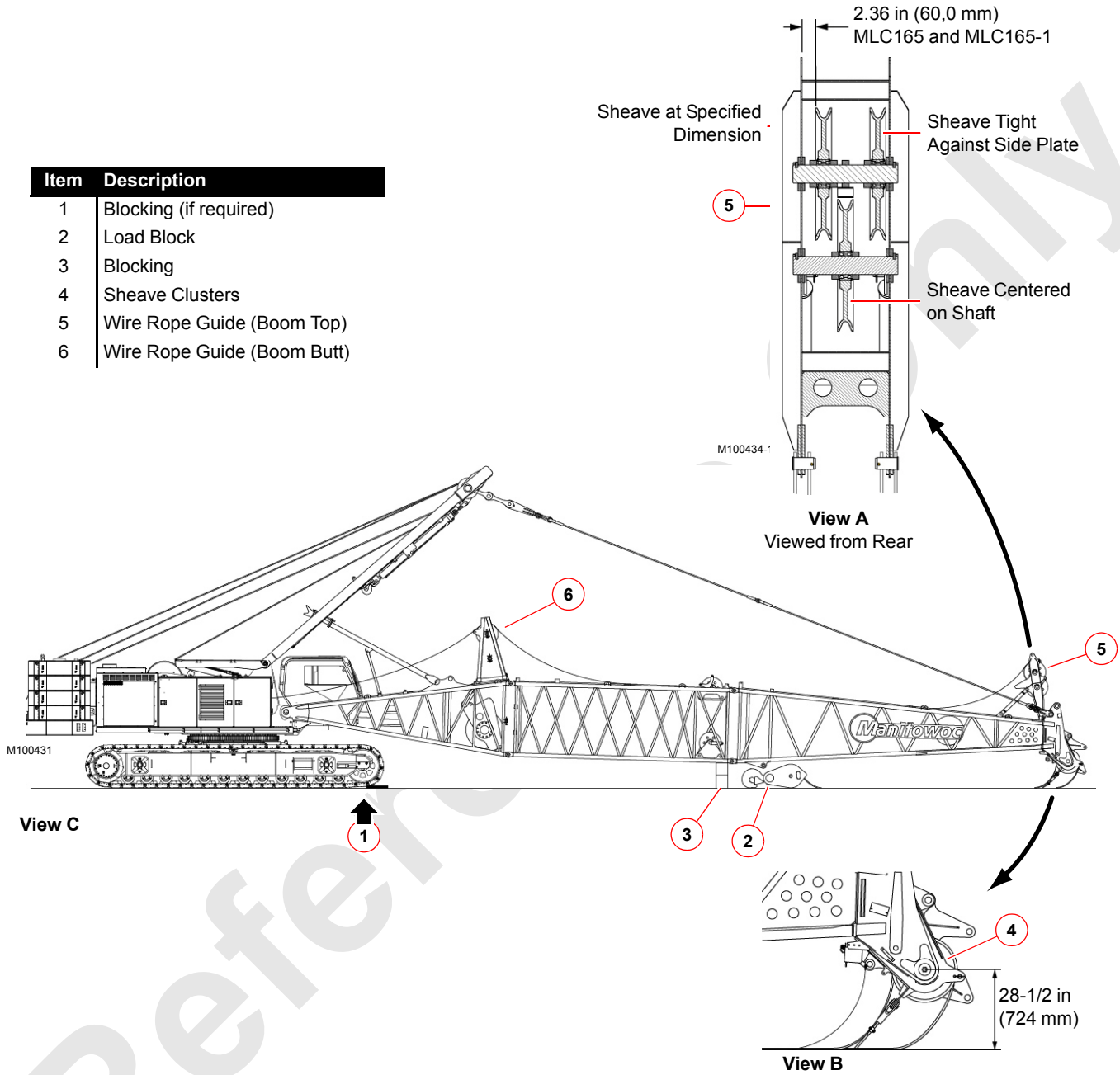

FIGURE 4-3

## PREPARING CRANE FOR LUFFING JIB

The instructions in this section assume that the crane and the boom are already fully assembled.

### Lower Boom

See [Figure 4-3](#)

1. Adjust the automatic boom stop to the specified angle for operation with a luffing jib. See Section 6 for adjustment procedure.
2. If blocking is required to raise and lower the luffing jib per the Luffing Jib Raising (and lowering) Procedure chart at the end of this section, proceed as follows:
  - a. Position the crawlers so the front crawler rollers are under the boom end of the upperworks.
  - b. Travel the front crawler rollers onto blocking (1).  
See the Capacity Chart Information folio in the Luffing Jib Capacity Chart Manual for blocking instructions.



### WARNING

#### Tipping Hazard!

Prevent the crane from tipping or structural failure of components:

- Raise and lower all boom and luffing jib combinations over the blocked front crawler rollers unless otherwise specified in the Luffing Jib Raising (and lowering) Procedure Chart at the end of this section.
3. Swing the boom slightly to either side of center and lower load block (2) and the hook and weight ball (if equipped) onto the ground.
  4. Swing the boom in-line with the crawlers and lower the boom onto blocking (3) so the centerline of the lower boom point is at the dimension given in View B.

This position will allow the luffing jib be installed horizontally on blocking approximately 4 in (102 mm) high.

## Prepare Boom for Jib

See [Figure 4-3](#)

1. Disconnect the required load lines and remove and store the hook and weight ball and/or the load block from the boom point.
2. Remove the fixed jib or the upper boom point, if equipped. See the procedures in Section 4 of the Crane Operator Manual.
3. Change the boom length as necessary to meet job requirements.
4. Check that all boom inserts and pendants are assembled in proper sequence according to the Boom Assembly Drawing in Section 4 of the Crane Operator Manual.
5. Remove sheave clusters (4), as required, from the lower boom point and replace them with spacers. See the procedure in Section 4 of the Crane Operator Manual.

For luffing jib operation with the lower boom point completely removed, the bolt and all spacers must also be removed.



### WARNING

#### Tipping Crane Hazard!

Do not attempt to raise more boom than specified when lower boom point sheave clusters are installed, otherwise rear of crane will tip forward.

6. Raise boom top wire rope guide (5) to the operating position. See the procedure in Section 4 of the Crane Operator Manual.

**NOTE** The boom top wire rope guide sheaves must be positioned as shown in View A.

7. Add or remove crane counterweight to comply with the applicable capacity chart. See the procedure in Section 4 of the Crane Operator Manual.

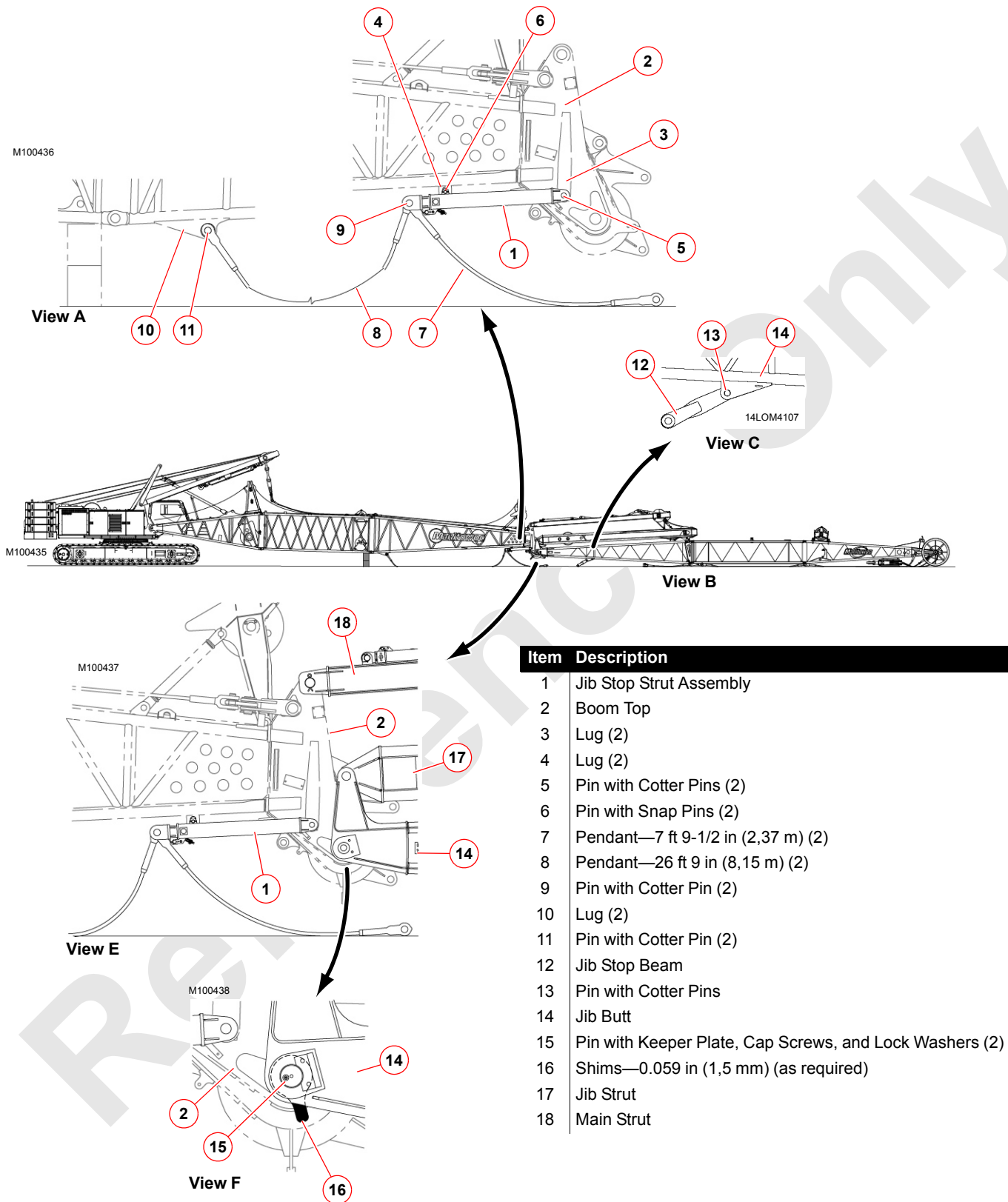

FIGURE 4-4

## INSTALLING LUFFING JIB

### Install Jib Stop Strut Assembly

See [Figure 4-4](#), View A

1. Lift jib stop strut assembly (1) into position under boom top (2) using a fork-lift truck.
2. Pin the jib stop strut assembly to boom top lugs (3 and 4) with pins (5 and 6).
3. Pin pendants (7 and 8) to the jib stop strut with pins (9).
4. Pin the other end of pendants (8) to lugs (10) on the underside of the boom top with pins (11).
5. Stretch pendants (7) along the ground toward the jib butt. These pendants will be connected to jib stop beam (12, View C) when the jib is raised.

### Install Jib Butt

See [Figure 4-4](#)

**NOTE** The jib butt, jib adapter, and jib strut are shipped as an assembled unit.

1. If not already installed, pin jib stop beam (12, View C) to jib butt (14) with pins (13).
2. Lift jib butt (14) into position at the end of boom top (2).
3. Pin the jib butt to the boom top lugs with pins (15) and keeper plates (View F).

As the pins are installed, install an equal number of shims (16, View F) on the outboard side of both boom top lugs **so jib butt is centered on boom top**.

4. Lower the jib butt onto blocking. Adjust the blocking so the centerline of the jib butt is horizontal to the ground.
5. Apply several shots of grease to both pins (15).

Item	Description
1	Jib Butt
2	Jib Insert—20 ft (6,1 m) Shown
3	Jib Adapter (ships attached to jib butt)
4	Pin with Cotter Pins
5	Jib Top

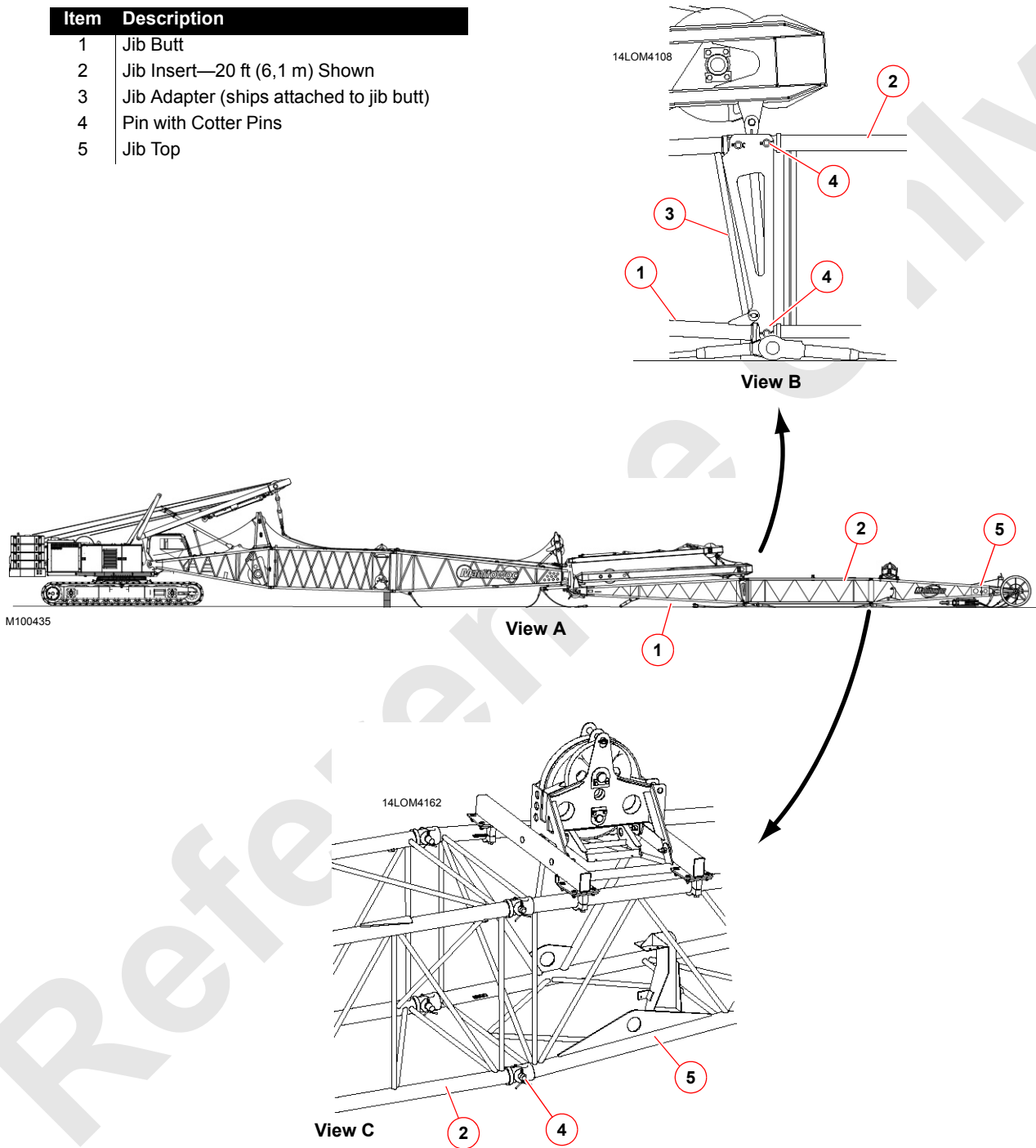

FIGURE 4-5



### Install Jib Inserts and Top

See [Figure 4-5](#)

1. Determine the jib length required for the lift to be made.
2. Using pins (4), pin the inserts and the jib top to the butt **in proper sequence—shortest inserts nearest butt** (see Luffing Jib Assembly drawing).
  - The long tapered end of pins (4) must be pointed in.
  - Block the sections so they are horizontal as assembly progresses.

### Connect Jib Stop Control Cable

See [Figure 4-6](#)

1. Pay out control cable (4, View A) from hand winch (2) on the jib top.
2. Connect control cable (4, View B) from the hand winch to cable extension (6) in the jib butt with shackle (5).
3. Route cable (6, View D) through sheave (7) on jib stop (1).
4. Connect control cable (6, View C) to cable (8) with shackle (5).
5. Pay out the control cable until it is resting on the bottom lacings of the jib sections.
6. The jib stop pins are spring engaged.

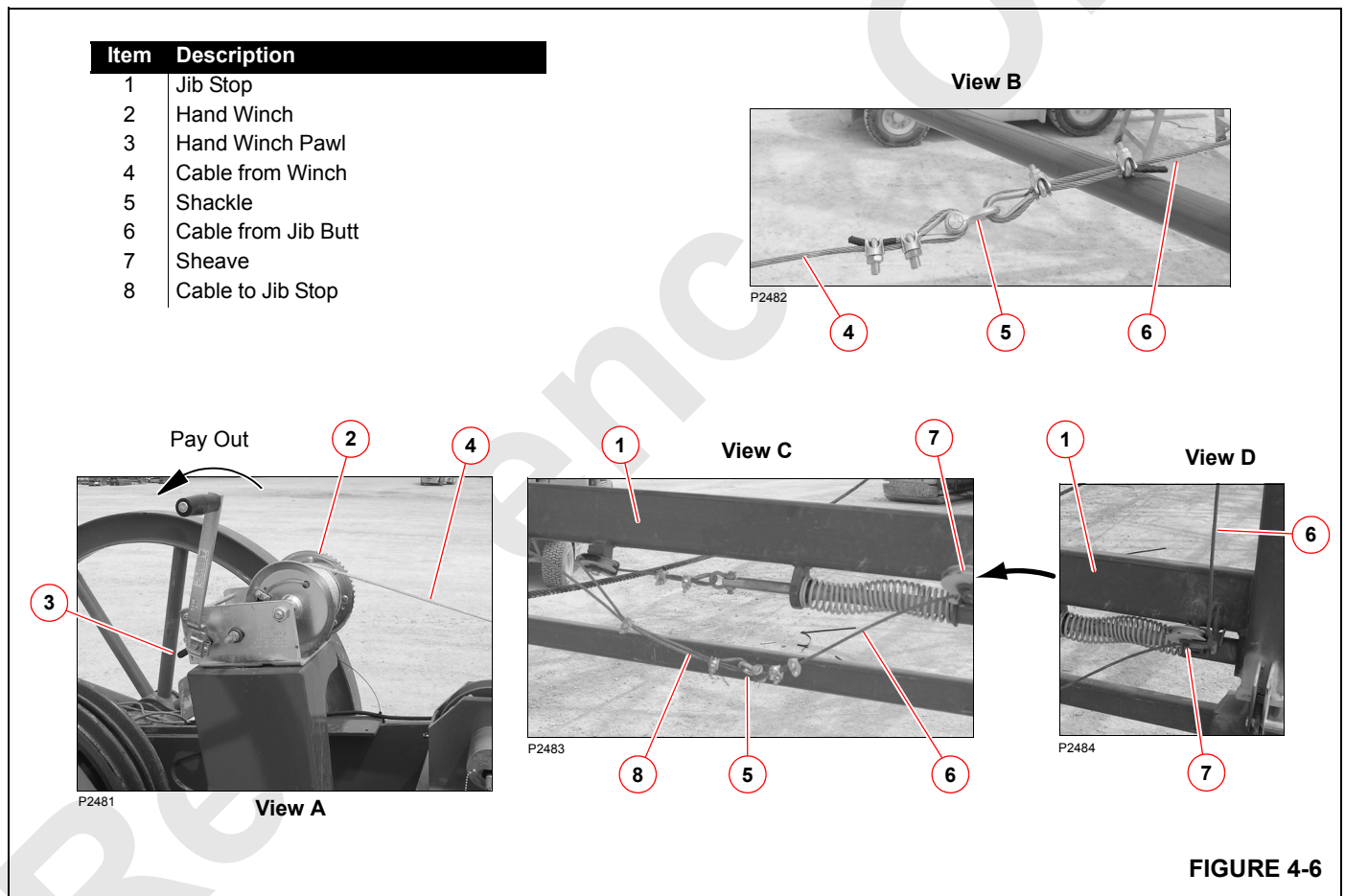

Item	Description
1	Basic Jib Pendants
2	Pendant Link
3	Main Strut
4	Jib Strut
5	Not Used
6a	Strut Support (erecting)
6b	Strut Support (stored)
7	Strut Support Pins
8	Jib Insert Pendant (install with jib inserts)
9	Jib Insert Pendant Link
10	Jib Butt
11	Main Strut Pin
12	Boom Top
13	Backstay Lug
14	Backstay Pendant
15	Boom Butt Wire Rope Guide
16	Jib Top
17	Pendant Link Pin
18	Pendant Link
19	Jib Top Pendant
20	Basic Backstay Pendant

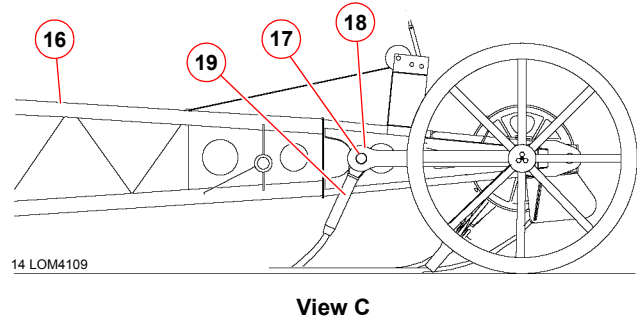
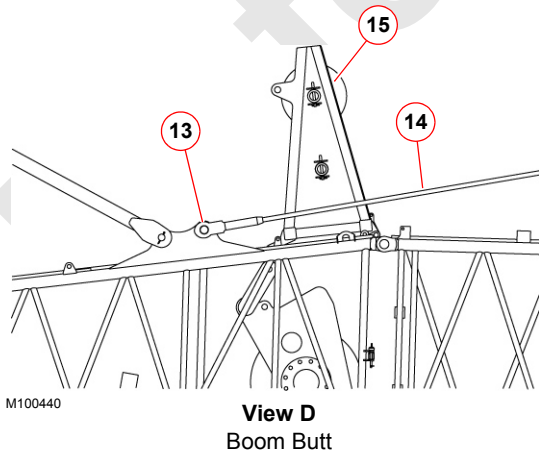
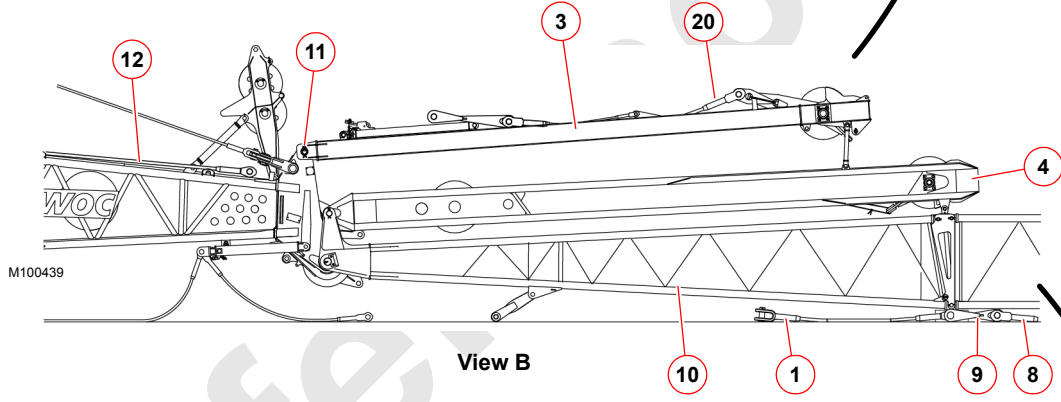
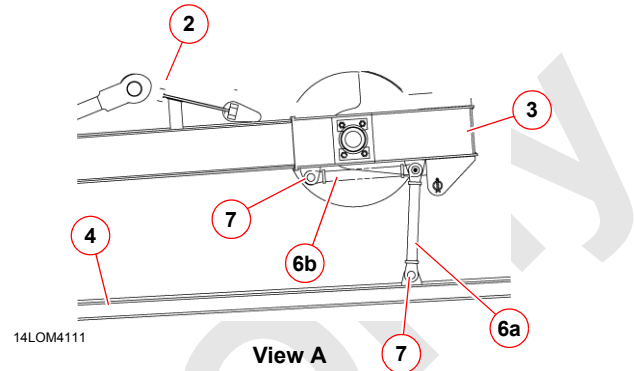

FIGURE 4-7

## Install Main Strut

See [Figure 4-7](#)

1. Make sure the main strut is positioned so pendant link (2, View A) faces up.
2. Pin main strut (3) to the lugs on boom top (12, View B) with pins (11).
3. Attach the main strut to the jib strut with strut supports (6a, View A).

## Install Jib Pendants

[Figure 4-7](#)

**NOTE** The jib pendants are shipped from Manitowoc in the coiled position and attached to fork-lift pallets.

If desired at disassembly, the jib pendants can be disconnected and left on top of the jib sections for shipping. This practice allows the jib to be reassembled faster.

It is the owner/user's responsibility to securely attach the pendants to the jib sections so the pendants cannot fall off the jib sections during transport.



### **WARNING** Falling Jib Hazard!

Jib pendants must be installed in same sequence as inserts—shortest inserts and pendants nearest butt.

Pendants are furnished in matched sets of two and must be installed in matched sets—pendant on one side of jib insert must match pendant on opposite side of jib insert. ***Failing to observe this precaution will cause jib to twist excessively when boom is raised. Structural damage to jib will occur.***

1. Pin basic jib pendants (19) to pendant links (18, View C) on jib top with pins (17).
2. While working toward the jib butt, continue to assemble and pin the required jib pendants on the ground alongside the jib.

3. If required, install pendant links (9, View B) between the last set of insert pendants (8) and basic jib pendants (1).

**NOTE** Pendant links (9) are required only for jib lengths 70 to 100 ft (21,34 to 30,48 m).

## Install Backstay Pendants

See [Figure 4-7](#)

**NOTE** The backstay pendants are shipped from Manitowoc in the coiled position and attached to fork-lift pallets.

If desired at disassembly, the backstay pendants can be disconnected and left on top of the boom sections for shipping. This practice allows the jib to be reassembled faster.

It is the owner/user's responsibility to securely attach the pendants to the boom sections so the pendants cannot fall off the boom sections during transport.



### **WARNING** Falling Boom Hazard!

Backstay pendants and links must be installed in sequence shown in Luffing Jib Assembly Drawing.

Pendants are furnished in matched sets of two and must be installed in matched sets—pendant on one side of boom insert must match pendant on opposite side of boom insert. ***Failing to observe this precaution will cause jib struts to twist excessively when boom is raised. Structural damage to jib or boom will occur.***

1. Assemble backstay pendants (14) and links in the proper sequence starting at backstay lugs (13, View D) on the jib butt.
2. Lay the pendants along the top of boom while working toward the boom top. Pull the pendants as tight as possible along the boom.

14LOM4161

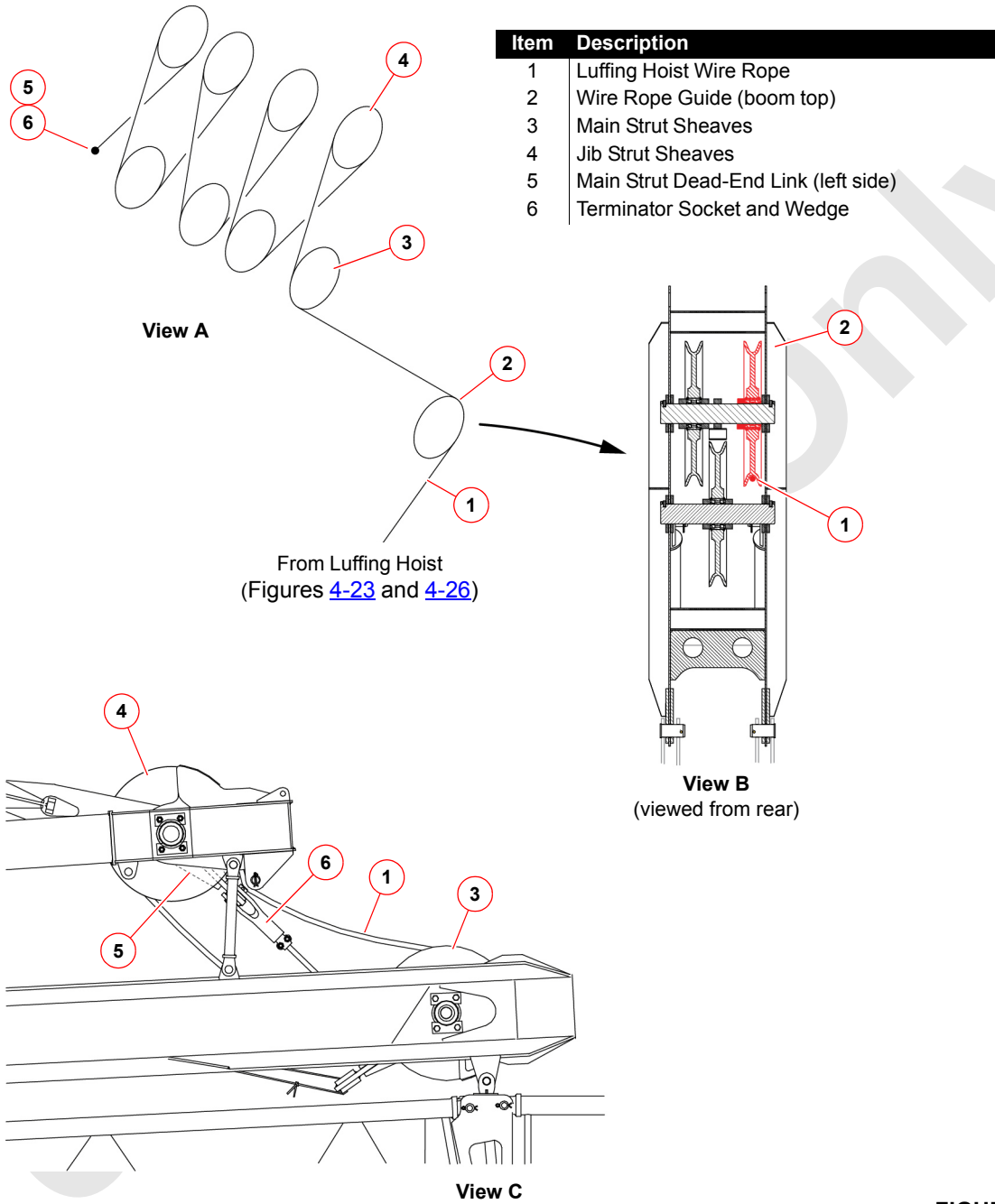

FIGURE 4-8

## Install Luffing Hoist Wire Rope

See [Figure 4-8](#)

1. Route luffing hoist wire rope (1, View A) from the luffing hoist around guide sheave (2) on the boom top (View B).
2. Route the wire rope around main strut sheaves (3) and jib strut sheaves (4, View A).

3. Anchor the free end of luffing hoist wire rope (1, View C) to left side dead-end link (5) on the main strut with socket and wedge (6).

See the Luffing Jib Assembly Drawing at the end of this section for recommended luffing hoist wire ropes.

See the Wire Rope Installation topic in this section for instructions on installing wire rope on a drum and for anchoring it to a wedge socket.

Reference Only

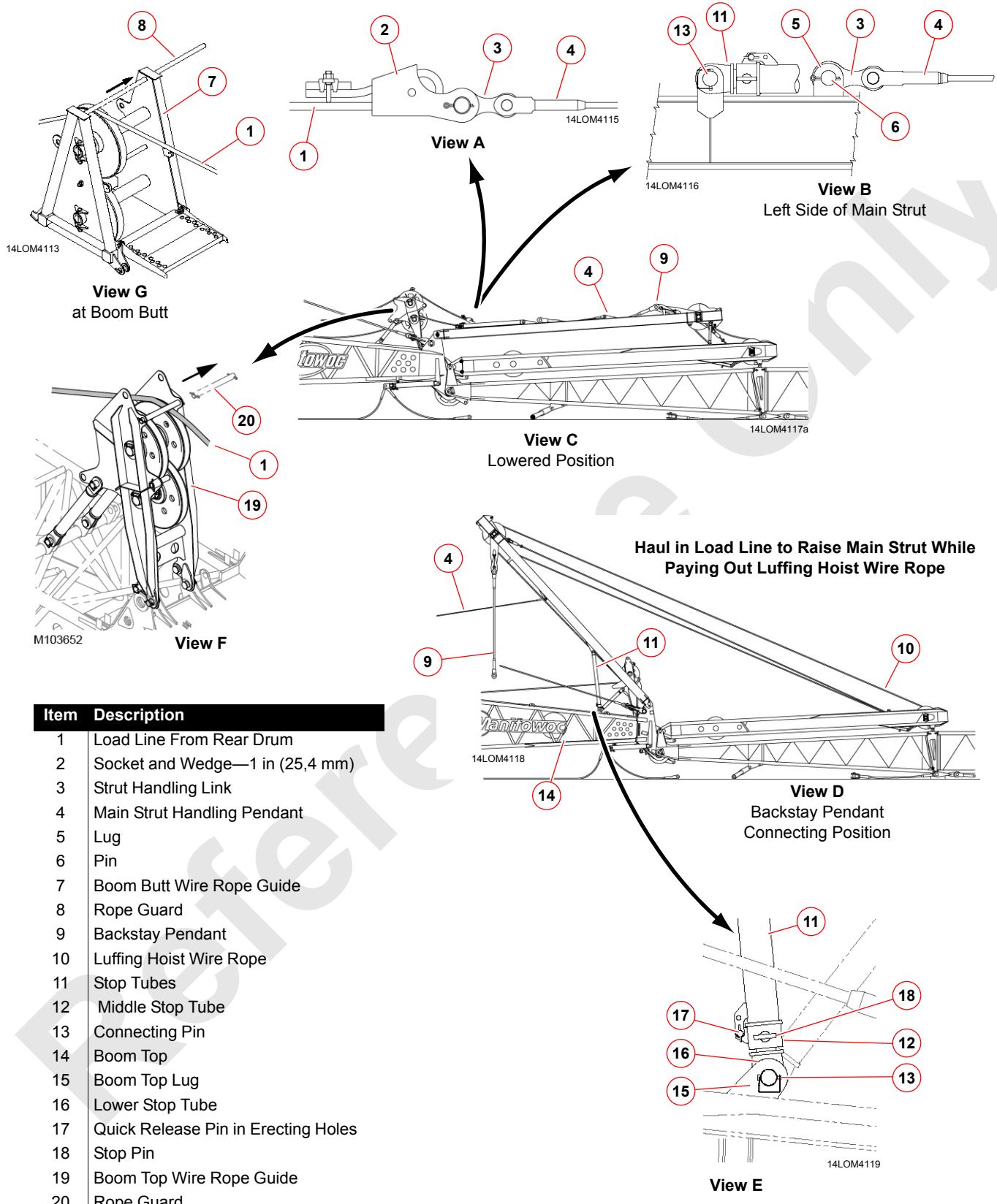

Item	Description
1	Load Line From Rear Drum
2	Socket and Wedge—1 in (25,4 mm)
3	Strut Handling Link
4	Main Strut Handling Pendant
5	Lug
6	Pin
7	Boom Butt Wire Rope Guide
8	Rope Guard
9	Backstay Pendant
10	Luffing Hoist Wire Rope
11	Stop Tubes
12	Middle Stop Tube
13	Connecting Pin
14	Boom Top
15	Boom Top Lug
16	Lower Stop Tube
17	Quick Release Pin in Erecting Holes
18	Stop Pin
19	Boom Top Wire Rope Guide
20	Rope Guard

FIGURE 4-9

## Raise Main Strut and Connect Backstay Pendants

See [Figure 4-9](#)



### WARNING

#### Moving Part Hazard!

Do not stand on boom top or jib butt while main strut is being raised or lowered.

Wait until main strut is stopped and supported by load line or luffing hoist wire rope before climbing onto boom top or jib butt when connecting and disconnecting strut stop tubes.

1. Unpin strut handling link (3, View B) from storage lugs (5) on the main strut.
2. Remove pins (13, View B).
3. Guide load line (1, View G) from the rear drum over the upper sheave in wire rope guide (7) on the boom butt.  
**Temporarily remove rope guard (8) or it will be damaged.**
4. Continue to guide load line (1, View F) over the left-upper sheave in the boom top wire rope guide (19).  
**Temporarily remove rope guard (20) or it will be damaged.**
5. Connect socket and wedge (2, View A) to load line (1) from the rear drum (this is same socket and wedge used to anchor load line at jib point).
6. Pin the socket and wedge to strut handling link (3, View A).
7. Haul in the load line just enough to support the main strut. Then, unpin the strut supports from the jib strut and pin the supports in storage position ([Figure 4-7](#), View A).

8. Slowly haul in the load line while paying out the luffing hoist wire rope to raise the main strut.

### CAUTION

#### Jib Strut Damage!

Do not allow luffing hoist wire rope to tension until main strut is near vertical. Jib strut could be damaged.

9. Tighten the luffing hoist wire rope as the main strut nears vertical so the strut moves smoothly past vertical.
10. Continue to haul in the load line and pay out the luffing hoist wire rope to lower the main strut to the rear (View D).  
**Keep load line slacker than luffing hoist wire rope so jib strut is not over tensioned.**
11. Stop lowering the main strut when the holes in lower stop tubes (16, View E) line up with the holes in lugs (15) on the boom top.
12. Pin the lower stop tubes (16, View E) to the lugs (15) on the boom top with pins (13).
13. Unpin the socket and wedge from the strut handling link and pin the link and pendant to the storage lugs on the main strut (View A).
14. Remove the socket and wedge (2, View A) from the rear drum load line and reinstall it at the jib point.
15. Pin basic backstay pendants (9, View D) from the main strut to the backstay pendants or links on the boom top (see Luffing Jib Assembly Drawing at end of this section for details).
16. Leave quick-release pins (17, View E) in the erecting holes.
17. Remove stop pin (18, View E) from both middle stop tubes (12).



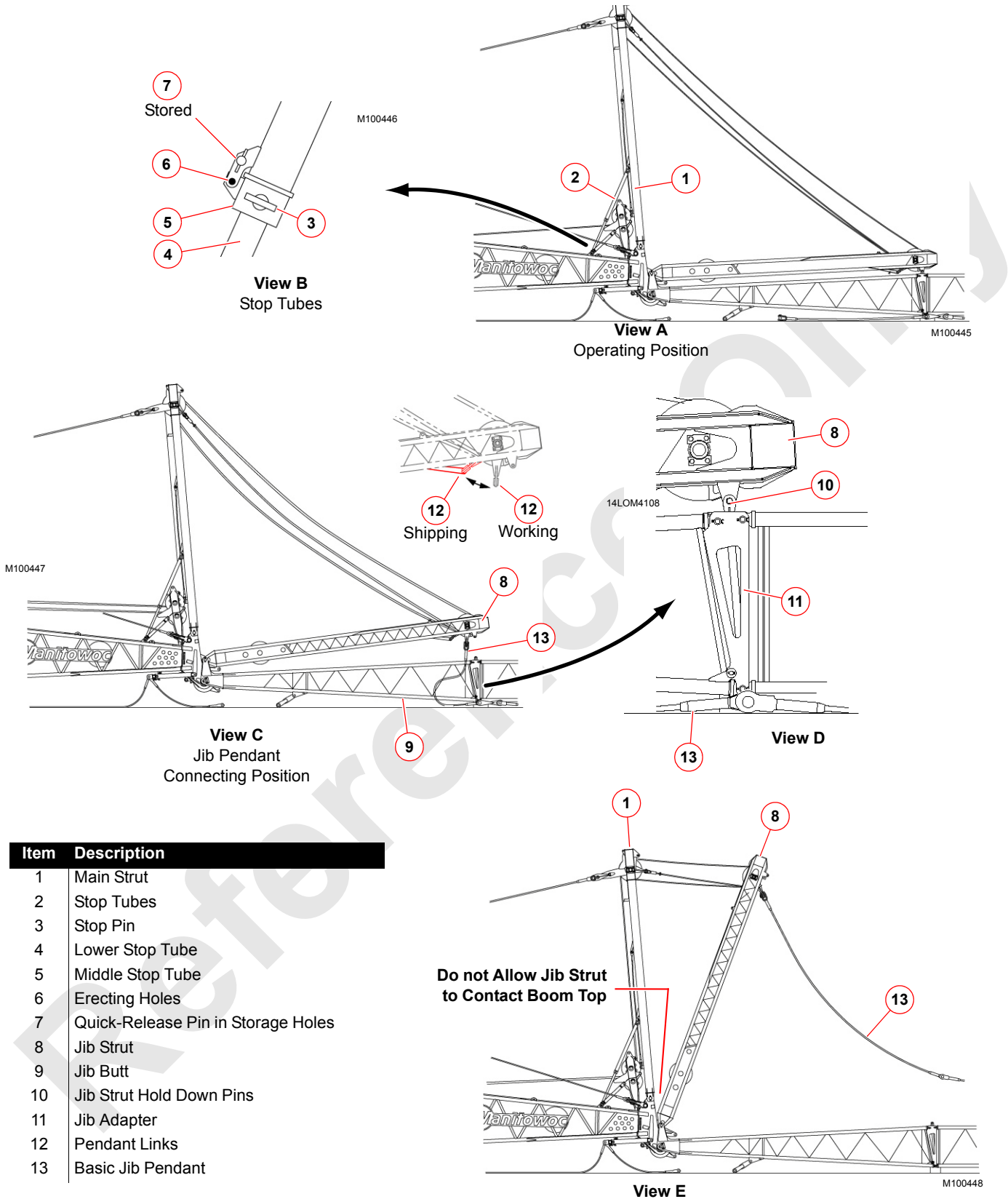

Item	Description
1	Main Strut
2	Stop Tubes
3	Stop Pin
4	Lower Stop Tube
5	Middle Stop Tube
6	Erecting Holes
7	Quick-Release Pin in Storage Holes
8	Jib Strut
9	Jib Butt
10	Jib Strut Hold Down Pins
11	Jib Adapter
12	Pendant Links
13	Basic Jib Pendant

FIGURE 4-10



See [Figure 4-10](#), View B

18. Slowly haul in the luffing hoist wire rope until the holes in both middle stop tubes (5) line up with the upper holes in both lower stop tubes (4).
19. Install stop pin (3) in both middle stop tubes (5).
20. Remove quick-release pins (7) from erecting holes (6) and install them in the storage holes.

### Connect Jib Pendants to Jib Strut

See [Figure 4-10](#)

1. Luff up or down as required, to loosen hold-down pins (10, View D) in the hold-down lugs.
2. Remove hold-down pins (10).
3. Luff up until jib strut (8, View C) is approximately 3 ft (1 m) above the jib butt.

4. Store hold down pins (10) in the hold-down lugs on adapter (11).
5. Lower pendant links (12, View C) from the shipping position to the working position.
6. Pin basic jib pendants (13, View C) to pendant links (12) on the jib strut.
7. Luff up to raise the jib strut until the jib pendants are just slightly above the top of the jib and stop (View E).

Guide the pendants while luffing up to prevent the pendants and connectors from striking the side of the jib.

---

#### CAUTION

##### Jib Strut Damage!

Do not allow jib strut to come into contact with boom top when luffing up. Jib strut damage could occur.

---

## INSTALL BOOM LOAD LINE

Depending on boom and jib length, it may be possible to handle loads from the lower boom point when equipped with a luffing jib. Keep in mind, however, that the weight of the load block, the load line, the slings, and other rigging hanging from the lower boom point must be deducted from the luffing jib capacities (see capacity charts for limitations).

1. If required for the boom and jib length in use, remove the lower boom point sheaves. See Luffing Jib Raising Procedure Chart for sheave removal requirements. See Section 4 of the Crane Operator Manual for removal instructions).
1. Determine the parts of line required for the job and size the load block accordingly.
2. Route the load line from the desired drum through the proper guide sheaves on the boom (see Section 4 of the Crane Operator Manual for details).
3. Reeve the load line through the lower boom point and load block sheaves and anchor the load line to the dead end (see Section 4 of the Crane Operator Manual for details).
4. Install the block-up limit for the lower boom point (see Section 4 of the Crane Operator Manual for details).

## INSTALL JIB LOAD LINE

The jib can be operated with up to 4-parts of load line over the jib point.

Install the load block or the hook and weight ball after the boom and jib are raised to the required boom to luffing jib angle.

1. Route the load line from the desired drum through the proper guide sheaves in the boom, in the jib strut, and in the jib point (see the Guide Sheaves and Drum topic on [page 4-39](#)).
2. Pull the load line approximately 20 ft (6,1 m) past the end of the jib and lay the load line on the ground.
3. Securely tie off the load line to the jib point using owner furnished slings.
4. Install the load block or the hook and weight ball after the boom and jib have been jack-knifed into position just prior to raising the jib point rollers off the ground.

5. Determine the parts of load line required for the job and size the load block accordingly (see the Wire Rope Specifications topic on [page 4-39](#)).

### CAUTION

#### Run-Away Wire Rope!

For long boom and short jib combinations, wire rope on boom side of attachment can overhaul unsecured wire rope on jib side. This could cause personnel injuries and damage to equipment. Securely tie off load line to jib before raising attachment.

6. Reeve the load line through the required jib point sheaves and anchor the load line at dead end on the jib, the load block, or on the hook and weight ball (see the Load Line Reeving topic on [page 4-39](#)).
7. Install the block-up limit for the jib point (see the assembly drawing at the end of this section).
8. Install the wind speed indicator assembly on the jib top (see the assembly drawing at the end of this section).
9. Install the position light on the jib top (see the assembly drawing at the end of this section).

## CONNECT ELECTRIC CORDS AND ADJUST ELECTRONIC DEVICES

1. Connect the electrical cords to the respective controllers and switches (see the assembly drawing at the end of this section):
  - Maximum jib stop limit switch on boom top
  - Minimum jib stop limit switch on boom top
  - Load sensing sheave on jib point
  - Block-up limit switches
  - Wind speed indicator
  - Position light
2. Adjust the electronic devices as instructed in Section 6:
  - Jib stop limit switches
  - Jib and boom block-up limit switches
  - Boom stop limit switch (set at 87° for boom with luffing jib)

## PRE-RAISING CHECKS

Make the following checks and correct any defects before raising the attachment.

- ❑ Crane on a firm, level, uniformly supporting surface.
- ❑ Boom and luffing jib assembled according to instructions in this section and in assembly drawings at end of this section.
- ❑ Proper counterweight installed per the Liftcrane Luffing Jib Capacities Chart being used.
- ❑ Crawlers blocked (if required for boom and jib length being raised).
- ❑ Boom and jib inserts installed in proper sequence according to assembly drawings.
- ❑ Boom, jib, backstay, and jib stop pendants installed in proper sequence according to assembly drawings.
- ❑ All connecting pins installed and properly secured.
- ❑ Main strut raised and main strut stop tubes pinned in operating position.
- ❑ Boom and luffing hoist wire rope anchored properly to drums, spooled tightly onto drums, and engaged with proper sheaves. Make sure rope guard pins, bars, or rollers are installed to retain wire rope in sheaves.
- ❑ Lower boom point sheaves removed (if required for boom and jib length in use).
- ❑ Load lines anchored properly to drums, spooled tightly onto drums, and engaged with proper sheaves. Make sure rope guard pins, bars, or rollers are installed to retain wire rope in sheaves.
- ❑ All blocking, tools, and other items removed from boom and jib.
- ❑ All blocking, tools, and other items removed from jib point roller path area.
- ❑ Pendants not hooked alongside boom and jib. **Guide pendant connectors clear of wire rope guides and boom and jib chords as boom and jib are raised.**
- ❑ All safety devices installed, electric cables connected, and limits adjusted (see appropriate adjustments in Section 6):
  - RCL/RCI (rated capacity limiter/indicator)
  - Automatic boom stop (must be adjusted to proper angle for luffing jib operation)
  - Automatic jib stops
  - Jib and boom block-up limits
- ❑ Luffing Jib Raising Procedure (at end of this section) read and thoroughly understood.
- ❑ Raising procedure in this section read and thoroughly understood.
- ❑ Wind within allowable limits for raising boom and jib.
- ❑ All lube points greased (see Lubrication Guide in Section 5).
- ❑ Proper Liftcrane Luffing Jib Capacity Chart selected in RCL/RCI configuration screen and displayed in working screen.
- ❑ All unnecessary personnel cleared from area.

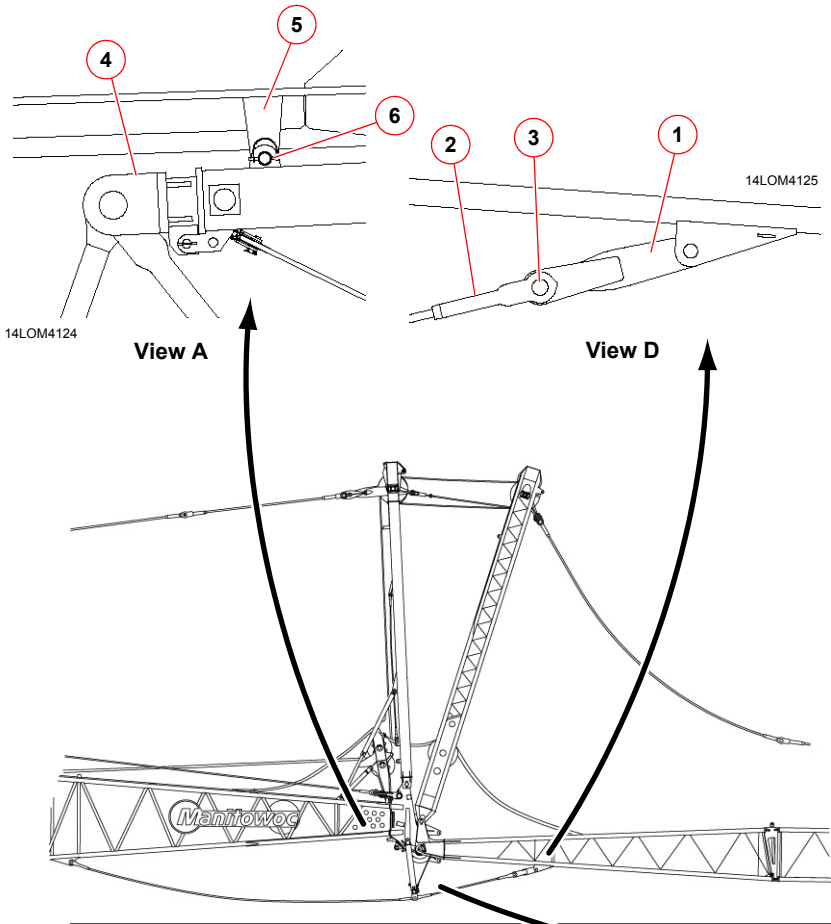

Item	Description
1	Jib Stop Beam
2	7 ft 9.5 in (2,37 m) Jib Stop Pendants
3	Pin
4	Jib Stop Strut (stored)
5	Boom Top Lug
6	Pins
7	Pin Storage Hole
8a	Quick-Release Pin (installed)
8b	Quick-Release Pin (stored)
9	Inner Strut
10	Outer Strut
11	Jib Stop Strut Pin (engaged)
12	Inner Strut (fully extended)

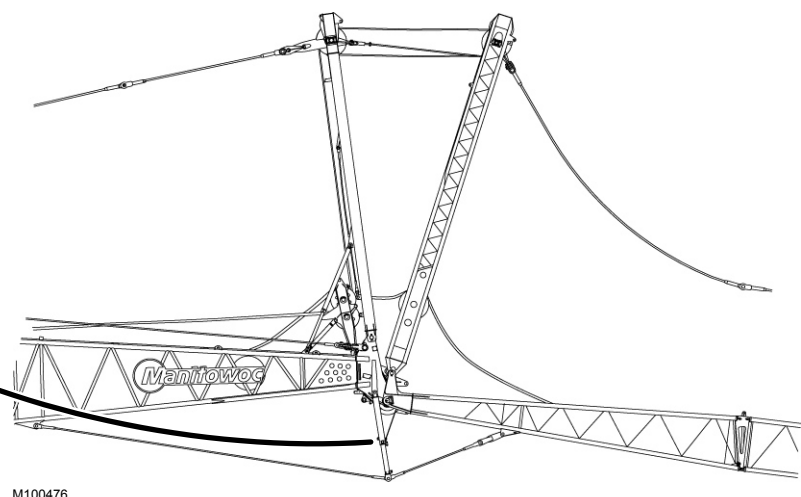
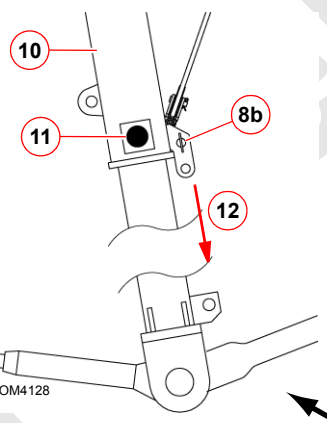
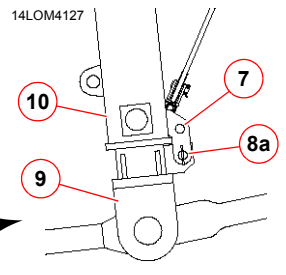
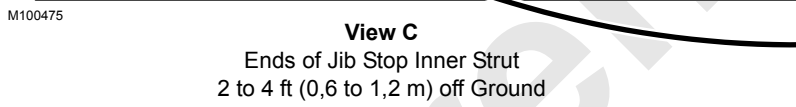

View E Boom to Jib Angle Approximately 168° **FIGURE 4-11**

## RAISING BOOM AND JIB



### WARNING

#### Falling Boom And Jib Hazard!

Select appropriate LUFFING JIB chart in RCL/RCI configuration screen. Operating in any other mode with luffing jib attached is prohibited.

Luffing jib limits are disabled when LUFFING JIB chart is not selected. Boom and jib could be pulled over backwards.



### DANGER

#### Moving Part Hazard!

Warn all personnel to stand clear of jib point rollers while raising boom and jib.

Death or severe crushing injuries will occur if personnel come into contact with rollers.

## Preliminary Raising Procedure

See [Figure 4-11](#)

- Using the hand winch on the left side of the jib top ([Figure 4-6](#), View A), slacken the jib stop control cable until it rests on the bottom lacings of the jib.  
***Jib stop inner strut will not extend properly and pins will not engage if control cable is tight.***
- Support jib stop strut (4, View A) with a fork-lift truck so it cannot fall and remove pins (6) holding the strut in the stored position.

- Lower the jib stop strut to the operating position (View B). Store pins (6, View A) in boom top lugs (5).
- Slowly boom up until the ends of jib stop inner strut (9, View B) are 2 to 4 ft (0,6 to 1,2 m) off the ground (View C).
- Pin jib stop pendants (2, View D) to jib stop beam (1) with pins (3).
- Stand to side of jib stop strut*** and remove quick-release pin (8a, View B) from both sides of the jib stop strut.

***Inner strut will extend slightly when this step is performed.***

- Store quick-release pins (8b, View F) in the storage holes (7, View B) on outer strut (10).
- Slowly boom up until the jib stop inner strut is fully extended (View E). The boom to luffing jib angle will be approximately 168°.

Jib stop strut pins (11, View F) should engage automatically when the inner strut is fully extended. ***Do not raise boom any higher until both pins are engaged.***

- NOTE** The outer ends of the jib stop strut pins (11, View F) are painted white (or other contrasting color) to make the pins more visible from the ground.
- Check that the jib stop control cable is slack: pay out the cable until it rests on the bottom lacings of the jib. ***Jib stop control cable must be slack at all times during luffing jib operation; otherwise, pins may disengage or cable may break.***

Numbered Step Correspond to Raising Procedure Steps

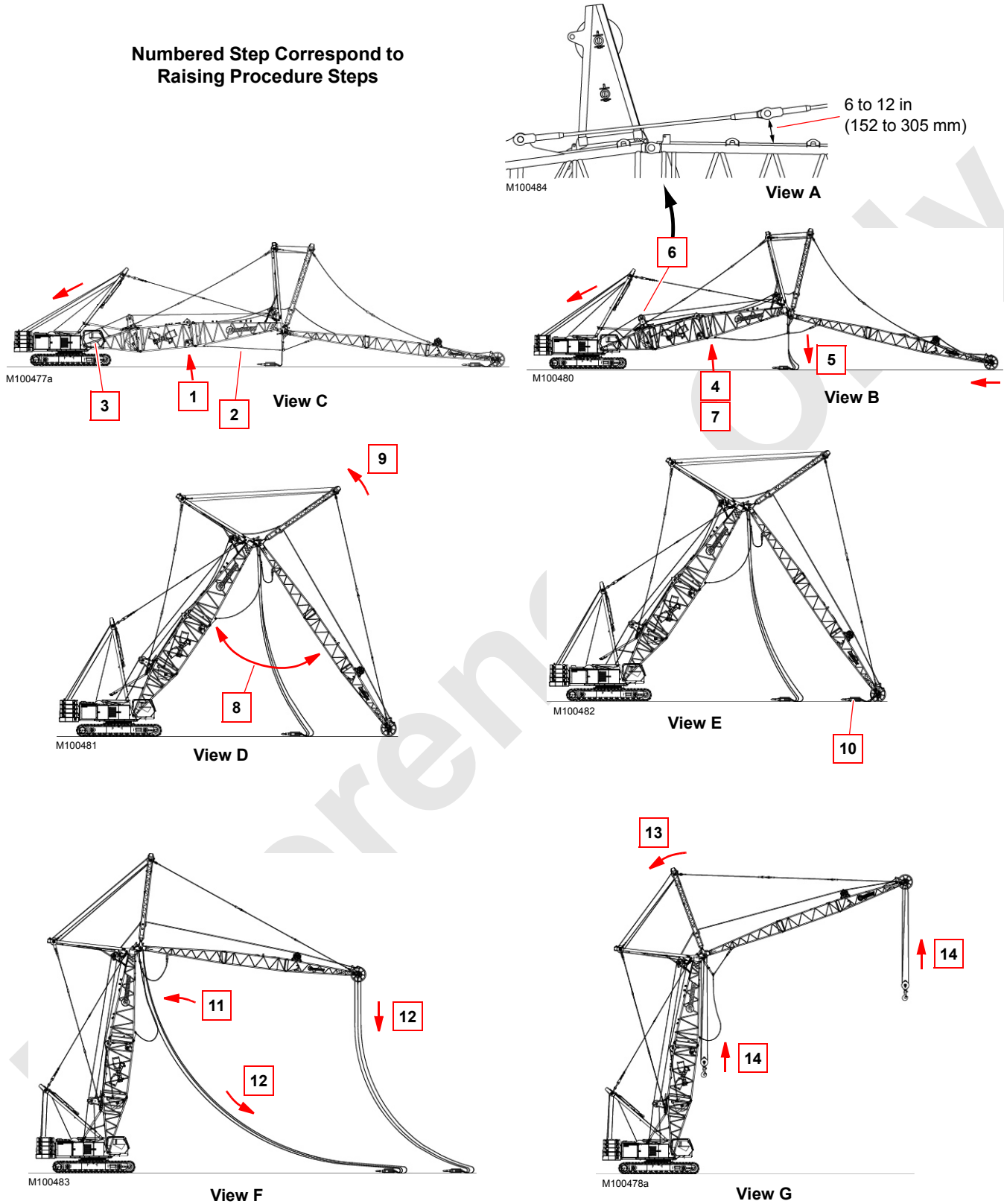

FIGURE 4-12

## Raising Procedure

The item numbers in [Figure 4-12](#) correspond to the numbered steps in the following procedure.



### WARNING

#### Tipping Hazard!

Determine BOOM TO LUFFING JIB ANGLE that boom and jib must be positioned at before jib can be raised (see Raising Procedure Chart). Crane will tip or structural damage will result if specified angle is not adhered to.

Monitor angle on digital display as boom and jib are raised.

### CAUTION

#### Structural Hazard!

Avoid possible structural damage to boom and jib from side loading as boom and jib are raised:

Disengage swing lock and release swing brake until boom and jib have been raised to required boom to luffing jib angle.

It is normal for the following fault limits to come on during the raising procedure:

- BLOCK UP fault will go off once the boom and luffing jib are raised and the load lines/block-up limit chains are hanging freely.
  - MAX UP fault will go off once the boom to luffing jib angle is less than 168°.
1. Determine the boom to luffing jib angle that the boom and jib must be raised to before the jib can be raised (see Luffing Jib Raising Procedure Chart).
  2. Perform the Preliminary Raising Procedure on [page 4-23](#).
  3. Disengage the swing lock and the release swing brake.
  4. Slowly boom up. The jib point rollers will roll along the ground as the boom and jib rise.
  5. Pay out the load lines as the boom is raised and the jib point rolls along the ground.



### WARNING

#### Tipping Crane Hazard!

Do not lift load blocks or hook and weight balls from ground until boom has been raised to desired operating angle and jib has been positioned at required operating radius. Crane could tip.

6. The jib and backstay pendants will tighten as the boom and jib rise.

Operator: watch the backstay pendants along the left side of the boom. Luff up and down, as required, while the boom and jib rise so the backstay pendant connectors nearest you remain 6 to 12 in (152 to 305 mm) above the boom chord. It will be necessary to use the limit bypass switch to luff down if the BLOCK UP fault is activated.



### WARNING

#### Tipping Hazard!

Do not allow jib and backstay pendants to become too tight during raising steps. Crane will tip or structural damage will result.

Do not allow jib and backstay pendants to become too slack during raising steps. Pendant connectors will bounce against boom and jib inserts, possibly resulting in damage.

7. Slowly continue with the Raising Procedure steps [4](#) – [6](#).
8. Stop raising when the boom and jib have been positioned at the required boom to luffing jib angle or the jib is vertical, whichever occurs first. **Monitor this angle on display screen.**
9. Slowly luff up until the jib and backstay pendants start to go into tension and stop.
10. Boom up to raise the jib point rollers clear of the ground, apply the swing brake, and install the load blocks or hook and weight balls at the jib point.



### WARNING

#### Falling Load Hazard!

Load line going up boom can overhaul load line going down jib. Do not untie load line from jib until load block or hook and hook and weight ball have been installed. Load line can fall off boom if this precaution is not followed.

11. Slowly raise the boom and jib to the desired boom angle. The luffing jib can be operated with the boom at one of six angles (see capacity chart for boom angles).
12. Pay out the load lines as the boom and jib are raised.
13. Position the jib at the required operating radius.
14. Lift the load blocks and/or the hook and weight balls to desired position.



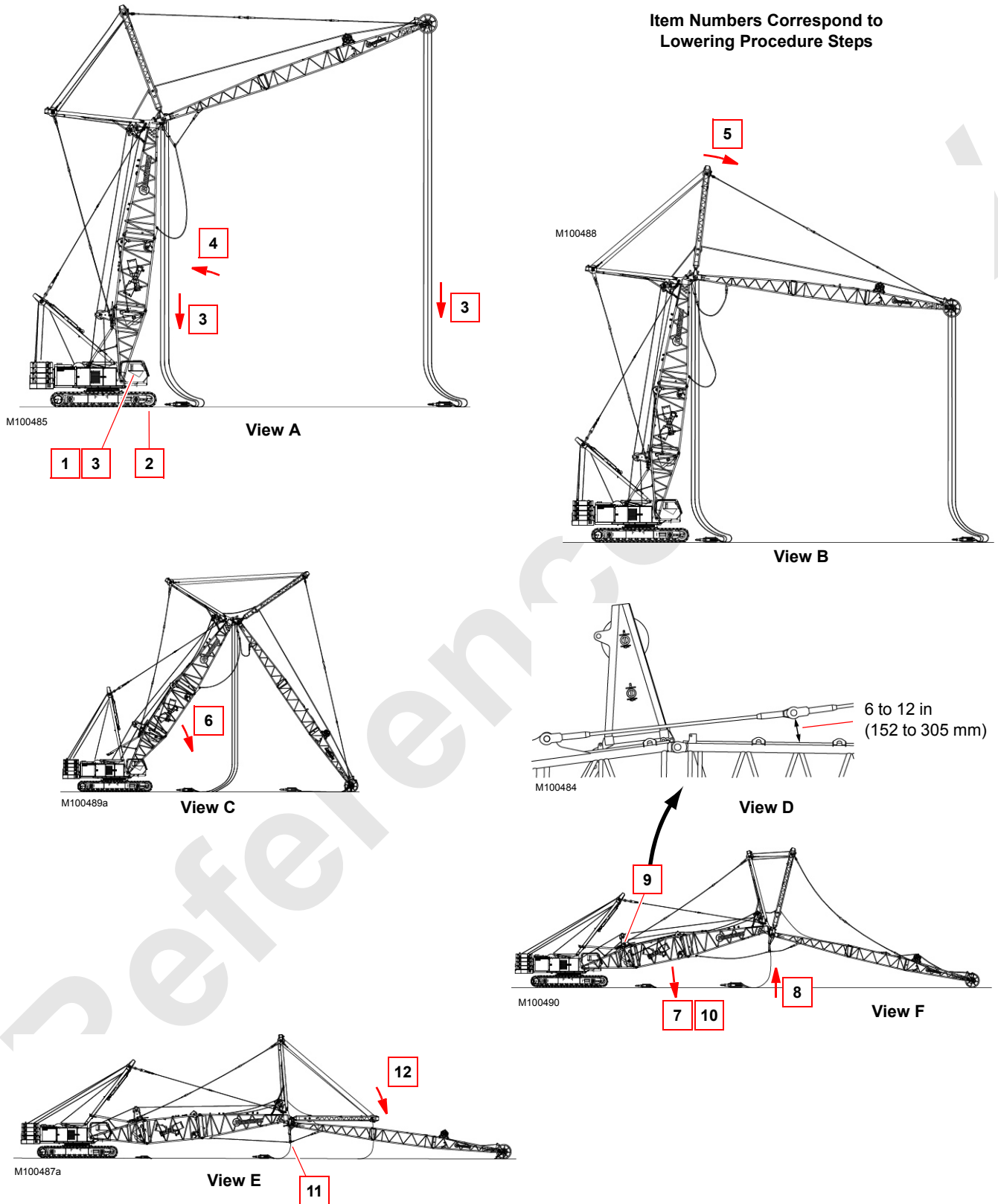

FIGURE 4-13



## LOWERING BOOM AND JIB



### WARNING

#### Falling Boom And Jib Hazard!

Select appropriate Liftcrane Luffing Jib Capacity Chart in RCL/RCI configuration screen. Operating in any other mode with luffing jib attached is prohibited.

Luffing jib limits are disabled when luffing jib chart is not selected. Boom and jib could be pulled over backwards.



### DANGER

#### Moving Part Hazard!

Warn all personnel to stand clear of jib point rollers while lowering boom and jib.

*Death or severe crushing injuries will occur if personnel come into contact with rollers.*

## Lowering Procedure

The item numbers in [Figure 4-13](#) correspond to the numbered steps in the following procedure.

**NOTE** It is normal for the BLOCK UP and the MAX UP fault to come on during the lowering procedure.

1. If blocking is required to lower the luffing jib per the Luffing Jib Raising (and lowering) Procedure at the end of this section, proceed as follows:
  - a. Position the crawlers so the front crawler rollers are under the boom end of the upperworks.
  - b. Travel the front crawler rollers onto blocking.  
See the Capacity Chart Information folio in the Luffing Jib Capacity Chart Manual for blocking instructions.



### WARNING

#### Tipping Hazard!

Prevent the crane from tipping or structural failure of components:

- Raise and lower all boom and luffing jib combinations over the blocked front crawler rollers unless otherwise specified in the Luffing Jib Raising (and lowering) Procedure Chart at the end of this section.
2. Swing the boom and jib slightly to either side of center and lower the load blocks and/or the hook and weight

balls onto the ground. Then swing the boom and jib in-line with the crawlers and apply the swing brake.



### WARNING

#### Tipping Crane Hazard!

Lower all load blocks and/or hook and weight balls onto ground before lowering boom and jib. Crane could tip if this step is not performed.

3. Raise the boom to a minimum angle of 85°.
4. Position the jib at the required boom to luffing jib angle (see Luffing Jib Raising Procedure Chart for angle).



### DANGER

#### Tipping Crane Hazard!

Do not lower boom and jib to ground until boom has been positioned at minimum boom angle of 85° and jib has been positioned at specified boom to luffing jib angle. Crane will tip.

### CAUTION

#### Boom or Jib Damage!

Avoid possible structural damage to boom and jib from side loading as boom and jib are lowered:

Disengage swing lock and release swing brake when jib point rollers contact ground.

### CAUTION

#### Boom or Jib Damage!

Do not under any condition allow boom to jib luffing angle to become less than 60°.

5. Slowly lower the boom until the jib point rollers contact the ground.

Depending on the boom and jib combination, the jib may be hanging vertical when the rollers contact ground. If this happens, raise the jib (luff up) until the jib is a few degrees forward of vertical.

It will be necessary to use the limit bypass switch to boom down if the BLOCK UP fault is activated.

6. Release the swing brake, disengage the swing lock, and continue to lower the boom slowly.

The jib point rollers will roll along the ground as the boom and jib are jack-knifed into position.

7. Haul in the load lines as the boom and jib are lowered.

**WARNING****Tipping Hazard!**

Do not allow jib and backstay pendants to become too tight during lowering steps. Crane will tip or structural damage will result.

Do not allow jib and backstay pendants to become too slack during lowering steps. Pendant connectors will bounce against boom and jib inserts, possibly resulting in damage.

8. The jib and backstay pendants will slacken as the boom and jib lower.

Operator: watch backstay pendants along the left side of boom. Luff up and down, as required, while the boom and jib lower so the backstay pendant connectors nearest you remain 6 to 12 in (152 to 305 mm) above the boom chord.

Use the limit bypass switch to luff down if the BLOCK UP fault is activated.

9. Continue lowering until the jib stop pendants start to go into tension (approximately 168° boom to jib angle). **Monitor this angle on display screens.**

**CAUTION****Jib Stop Damage!**

Once jib stop pendants start to go into tension, do not lower boom any farther until jack-knife lowering step [10](#), is performed. Damage to jib stop struts or pendants will result if struts are over tensioned.

10. Retract and store the jib stop struts. Perform the Final Lowering Procedure on [page 4-28](#).
11. The jib struts and main struts can now be lowered, if required. See Lowering Jib Strut and Main Strut topic on [page 4-28](#).

**Final Lowering Procedure**

See [Figure 4-11](#)

Perform the following steps once the boom and jib have been lowered to the point that the jib stop pendants start to go into tension (approximately 168° boom to jib angle).

1. Disengage the jib stop strut pins with the hand winch on left side of jib top ([Figure 4-6](#), View A).

**NOTE** The outer end of the jib stop strut pins are painted white (or other contrasting color) to make the pins more visible from the ground.

2. Slowly lower the boom to retract the jib stop inner strut.  
Use the limit bypass switch to boom down if the BLOCK UP or the MAX UP fault is activated.
3. Stop lowering the boom when the jib stop inner strut is fully retracted (View B).
4. Remove both quick-release pins (8b, View F) from the storage holes (7) and install pins (8a, View B) to connect the jib stop inner strut to the outer strut in the retracted position.
5. Unpin both jib stop pendants (2, View D) from jib stop beam (1) and lower the pendants to the ground.
6. Rotate jib stop strut (4, View A) rearward and pin it to the boom top for storage.
7. Lower the boom top onto blocking so the center of the lower boom point shaft is at the dimension shown in [Figure 4-3](#), View B.
8. Lower the jib strut and the main strut if required.

**Lowering Jib Strut and Main Strut****WARNING****Moving Part Hazard!**

Do not stand on boom top or jib butt while main strut is being raised or lowered.

Wait until main strut is stopped and supported by load line or luffing hoist wire rope before climbing onto boom top or jib butt when connecting and disconnecting strut stop tubes.

See [Figure 4-10](#)

1. Luff down to lower the jib strut (8, View C) to approximately 2 ft (0,6 m) above the top of the jib and stop (View C).  
Guide the pendants while luffing down so the pendants and connectors do not strike the side of the jib.
2. Unpin basic jib pendants (13, View C) from pendant links (12) on the jib strut. Lower the pendants to the ground.
3. Rotate pendant links (12, View C) as close to the underside of the jib strut as possible and tie the links to the strut with owner furnish slings, wire, or rope.

4. Remove hold-down pins (10, View D) from the stored position in the hold-down lugs on the jib adapter.
5. Pay out the luffing hoist wire rope as required to lower jib strut (8, View D) to the hold-down pin position.
6. Pin the jib strut to hold-down lugs (View D).
7. Remove quick-release pins (7, View B) from the storage holes in the main strut stop tubes and install both quick-release pins in erecting holes (6). It may be necessary to luff up or down slightly to align the holes.
8. Remove both stop pins (3, View B). It may be necessary to luff up or down slightly to loosen the pins.

See [Figure 4-9](#)

9. Pay out the luffing hoist wire rope to lower the main strut until the holes in middle stop tubes (12, View E) line up with the bottom holes in lower stop tubes (16).
10. Install stop pins (18, View E) to connect middle stop tubes (12) to lower stop tubes (16).
11. Unpin basic backstay pendants (9, View D) on the main strut from the backstay pendants or links on the boom. Lower the pendants onto the boom top.
12. Remove the load block or the hook and weight ball from rear drum load line (if attached).
13. Guide load line (1, View G) from the rear drum over the upper sheave in wire rope guide (7) on the boom butt.

**Temporarily remove rope guard (8) or it will be damaged.**

14. Continue to guide the load line (1, View F) over the left-upper sheave in the boom top wire rope guide (19).

**Temporarily remove rope guard (20) or it will be damaged.**

15. Remove the socket and wedge from the jib point and attach it to the load line from the rear drum (View A).
16. Unpin strut handling link (3, View B) and pendant (4) from the storage lugs on the main strut.
17. Pin the socket and wedge on load line from rear drum to strut handling link (3, View A).
18. Haul in the rear drum load line so the load line and strut handling pendant are just slightly slack.

**Keep load line slacker than luffing hoist wire rope so jib strut is not over tensioned.**

19. Unpin lower stop tubes (16, View E) from the lugs on the boom top. It may be necessary to luff up or down to loosen the pins.
20. Slowly pay out the load line while hauling in the luffing hoist wire rope to raise the main strut to vertical.

21. Tighten the load line as the main strut nears vertical so the strut moves smoothly forward past vertical.
22. Continue to lower the main strut to approximately 3 ft (1 m) above the jib strut.

See [Figure 4-7](#), View A

23. Unpin strut supports (6b) from the storage position and allow them to hang vertically. Slowly pay out the load line to lower the strut supports to the lugs on the jib strut.

24. Pin the strut supports (6a) to lugs on the jib strut.

See [Figure 4-9](#)

25. Pin strut stop tubes (11, View B) to the main strut.
26. Unpin strut handling link (3, View A) from socket and wedge (2) and pin the link and pendant to the storage lugs on the main strut (View B).

27. Remove the socket and wedge from rear drum load line and store.

## Removing Jib

Removing the jib is the opposite of installing it. The luffing jib butt and jib strut can be removed and shipped as an assembled unit.

**NOTE** The automatic boom stop must be reset to 81.7° for operation without the luffing jib (see Automatic Boom Stop topic in section 6).

Remove and store the wind speed indicator assembly and the position light so they are not damaged during shipping.



## WARNING

### Collapsing Boom/Jib Hazard!

Improper disassembly of boom and jib sections can cause boom or jib to collapse onto personnel removing connecting pins.

Death or serious injury can result if precautions listed below are not taken:

- Lower boom/jib so boom and jib points are supported on blocking on ground.
- Slacken rigging—do not attempt to remove connecting pins while boom or jib is supported by rigging.
- Block below both ends of each boom or jib section before removing connecting pins.
- Stand on outside of boom or jib sections when removing connecting pins. Never work under or inside boom or jib sections. Use care not to damage lacing and chords as pins are knocked out.

## WIRE ROPE INSTALLATION

**NOTE** The wire rope manufacturer's recommendations take precedence over the information in this section.

### Wire Rope Storage

Store the wire rope in coils or on reels off the ground or floor in a clean and dry indoor location. If outdoor storage is necessary, the wire rope must be covered with a protective wrapper. Keep the wire rope away from acids, fumes, and other corrosives. Keep the wire rope away from heat that can dry out the lubricant. For extended storage periods, lubricate the wire rope and perform the periodic inspection given in this section at least monthly.

### Removing Wire Rope from Shipping Reel

#### CAUTION!

##### Wire Rope Damage!

Shipping reel must rotate when wire rope is unwound. Attempting to remove wire rope from a stationary reel can result in a "kinked" wire rope and wire rope will be ruined.

1. Mount the wire rope shipping reel on a shaft supported at both ends by jacks or blocks as shown in [Figure 4-14](#).

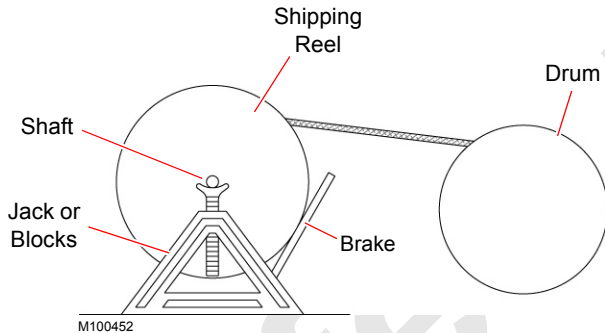

FIGURE 4-14

2. Provide a brake at the shipping reel ([Figure 4-15](#)) so the wire rope can be wound tightly onto the drum.

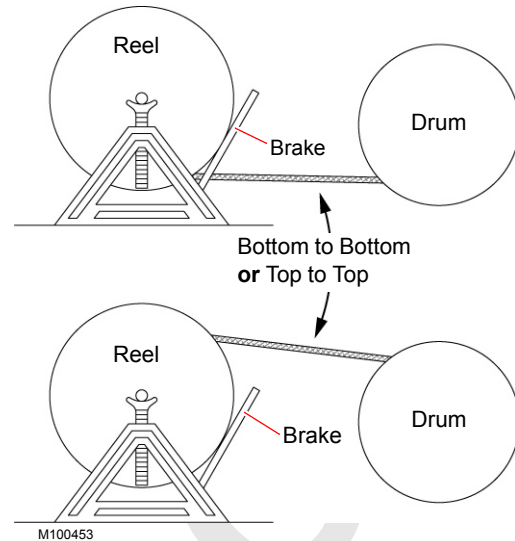

FIGURE 4-15

3. **Avoid a reverse bend when winding wire rope onto drum.** Wind wire rope from the top of the reel to the top of the drum or from the bottom of the reel to the bottom of the drum as shown in [Figure 4-15](#).
4. Avoid dragging the wire rope in dirt or around objects that can scrape, nick, cut, or crush the wire rope.

### Seizing and Cutting Wire Rope

Apply tight seizings of annealed wire to the ends of all wire rope. If not done, the rope wires and strands may slacken. This action will result in overloading of some strands and underloading of others. Bird caging and breakage of the wire rope can occur.

Before cutting wire rope, apply seizings on both sides of the point where the cut will be made. Then cut the wire rope with a torch, rope cutter, or abrasive cut-off wheel.

See [Figure 4-16](#) for:

- The number of seizings to be applied to the ends of the wire rope and to both sides of the point where a cut will be made.
- The proper application method. Each seizing should be one rope diameter long.

Wire Rope Type	Seizings Required
Preformed	1
Non-preformed	3

Place free end of seizing wire in valley between two stands. Then wind seizing wire over free end as shown. Finally, twist and pull two ends of seizing wire together until seizing is tight.

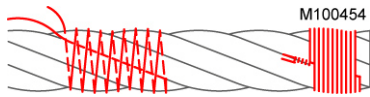

View A—Rope Diameter 1 in (26 mm) and Larger

Wind seizing wire around wire rope as shown. Then twist two ends of seizing wire together at center of seizing. Alternately twist and pull ends until seizing is tight.

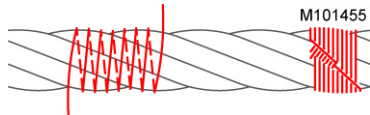

View B—Rope Diameter Smaller than 1 in (26 mm)

A925

FIGURE 4-16

### Anchoring Wire Rope to Drum

See [Figure 4-17](#)

Use the correct keeper plates for the size of wire rope being used. See the Luffing Hoist and Drum Shaft Drawings in the Parts Manual for your crane for the correct part numbers.

1. Loosely fasten the keeper plates to the drum flange.
- NOTE** Apply Loctite™ 271 to the bolt threads.
2. Route the wire rope from the drum through the hole in the drum flange.
  3. Route the wire under the keeper plates.
  4. Tighten the bolts to 295 ft-lb (400 Nm).

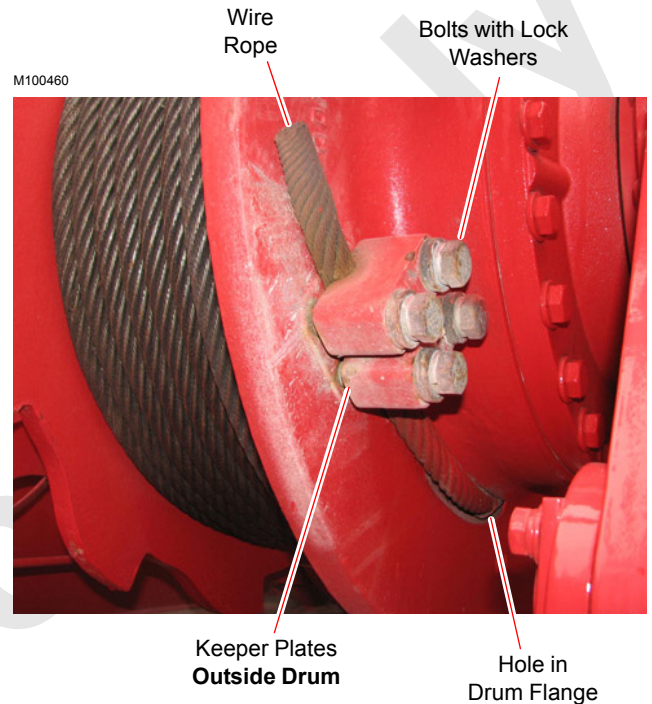

FIGURE 4-17



## Winding Wire Rope onto Drum

See [Figure 4-18](#)

See the Drum and Lagging Chart in the Capacity Chart Manual for the correct size of drum laggings, if used.

See the Wire Rope Specifications Chart in the Capacity Chart Manual for the correct type, size, and amount of wire rope to be installed on the load drums.

See the Boom and/or Luffing Jib Assembly Drawing at end of this section for the correct type, size, and amount of wire rope to be installed on the boom hoist drum or the luffing hoist drum.

1. Carefully inspect the drums and all rope guides, rollers, and sheaves for defects that can cause the wire rope to wear or be cut. If the defects cannot be fixed, replace the faulty parts.

2. Apply tension to the wire rope as it is wound slowly onto the drum.

The first wrap must be tight against the drum flange for approximately three-fourths of the drum diameter ([Figure 4-18](#), View A).

3. Tap the adjacent wraps against each other with a soft metal or wooden mallet.

Use extreme care not to put twists or turns in the wire rope; allow the rope to assume its natural lay.

### CAUTION!

#### Wire Rope Damage!

Voids or spaced wraps in first layer (View B) will permit movement and a wedging action with subsequent layers. Wedging action will cause crushing and abrasion of wire rope.

Never allow wire rope to “cross wind” on drums.

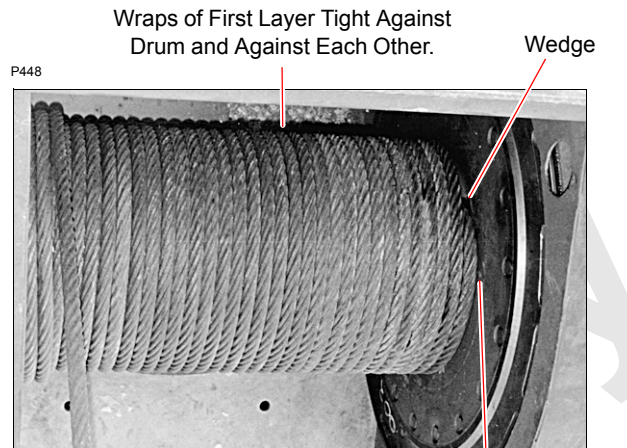

View A

First Wrap Tight Against Flange for 3/4 of Diameter.

Voids and Loose Wraps in First Layer Cause Severe Wear of Wire Rope.

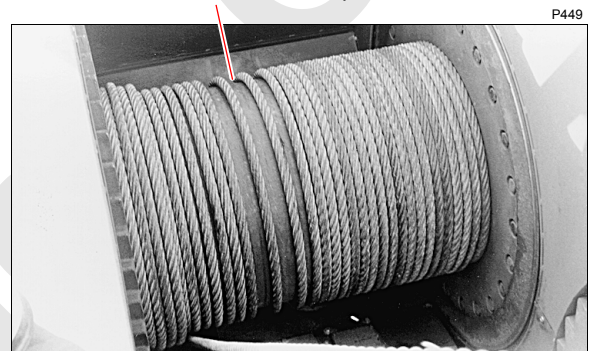

View B

FIGURE 4-18

Reference Only

*THIS PAGE INTENTIONALLY LEFT BLANK*

<b>TL (Tail Length)</b>
<b>Standard 6 to 8 Strand Wire Rope</b>
Minimum of 6 rope diameters, but not less than 6 in (152 mm).
<b>Rotation Resistant Wire Rope</b>
Minimum of 20 rope diameters, but not less than 6 in (152 mm).

T (Rope Clip Nut Torque)

inch (mm)	Wire Rope/Clip Size			
	7/8 (22,23)	1 (25,4)	1-1/8 (28,58)	1-1/4 (31,75)
<b>Torque</b>				
* ft/lb (kN/m)	225 (0,30)	225 (0,30)	225 (0,30)	360 (0,49)

\* Tightening torque values shown are based on threads being clean, dry and free of lubrication.

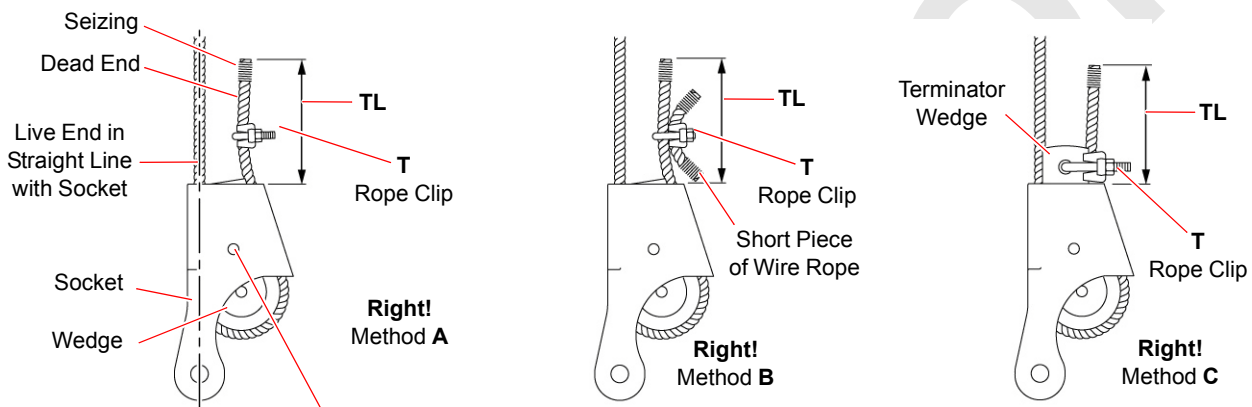

**Do not reinstall any shipping material** (bolt, plastic strap, or wire) in hole of wedge or socket after assembling.

M100457

**ALL ARE DANGEROUS AND PROHIBITED!**

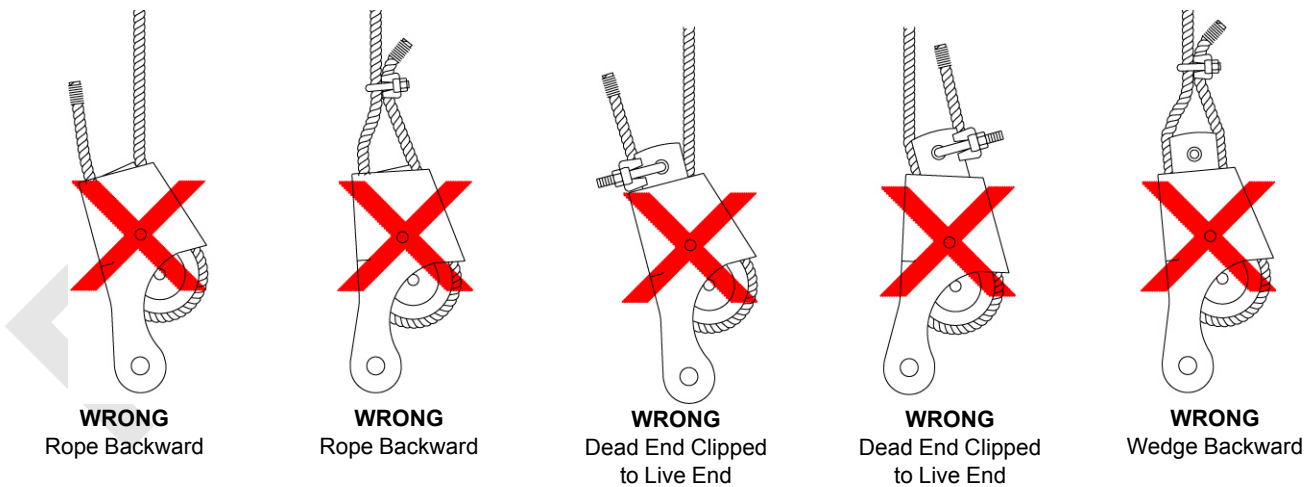

M100457

FIGURE 4-19



## Anchoring Wire Rope to Wedge Socket

**! WARNING**  
**Falling Load Hazard!**

- Inspect all parts prior to use. Do not use parts that are cracked or otherwise defective.
- Remove minor nicks, burrs, or rough edges from socket, wedge, or pin by lightly grinding. Do not reduce original dimensions by more than 10%.
- Do not reinstall shipping material (bolt, plastic strap or wire) in hole of wedge or socket after assembling. Discard these materials because they can prevent wedge from tightening in socket.
- Only use a wedge and socket which are correct size for wire rope being used. Do not mix and match parts from one assembly with parts from another assembly.
- Terminator™ socket and wedge has “go” and “no go” holes to check for proper rope size.
- Attach wire rope clip to dead end of wire rope after assembling wire rope to wedge and socket.
- If dead end of wire rope is welded, seize end of wire rope and cut off weld before assembling to wedge and socket. Weld will not allow strands of wire rope to adjust around bend of wedge, resulting in high strands and wavy rope. This condition can seriously weaken attachment.

See [Figure 4-19](#)

1. Assemble the wire rope and the wedge to the socket so the live end of the wire rope is in a straight line with the socket pin hole. Do not assemble WRONG as shown.
2. Allow the dead end of the wire rope to extend past the end of the socket the amount shown.
3. Allow the wire rope to assume its natural lay.
4. Pull against the wedge and live end of the wire rope enough to tighten the wedge in the socket.
5. Use a brass hammer to seat the wedge and wire rope as deep into socket as possible.
6. Attach a wire rope clip to the dead end of the wire rope using one of the RIGHT methods shown. The rope clip

will aid in preventing the wire rope from being pulled out of the socket.

**NOTE** Use Right Method A only if the wire rope clip is small enough to be securely tightened to the dead end. Right Method C is only for use with a Terminator wedge socket.

7. After the socket is pinned in place, hoist the load slowly so the wedge seats tightly. Do not shock load socket and wedge.

**! WARNING**  
**Falling Load Hazard!**

Wire rope can break if following precaution is not observed:

- Do not attach dead end of wire rope to live end of wire rope with wire rope clip. Wire rope clip will transfer load from live side of wire rope to dead end, seriously weakening attachment.

## Anchoring Wire Rope to Button Socket

See [Figure 4-20](#)

1. Remove the pin from the socket.
2. Install the button end of load line in the socket.
3. Pin the socket to the anchor point.
4. Securely tighten the locking screw.

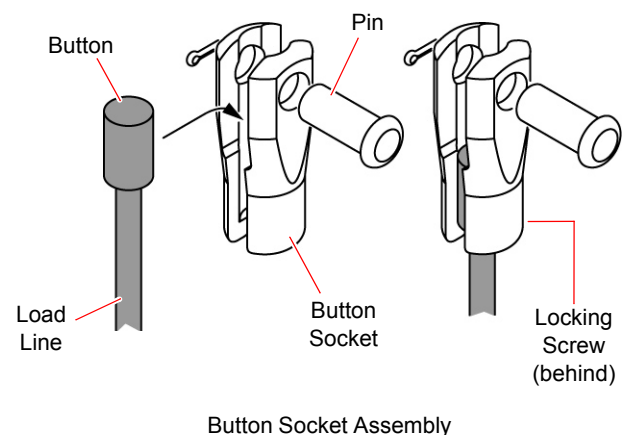

M100459

**FIGURE 4-20**

M100461  
M100462  
M100463

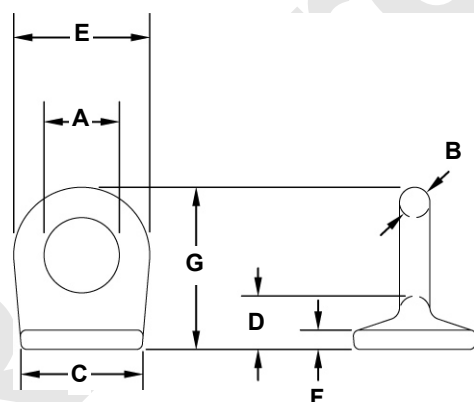
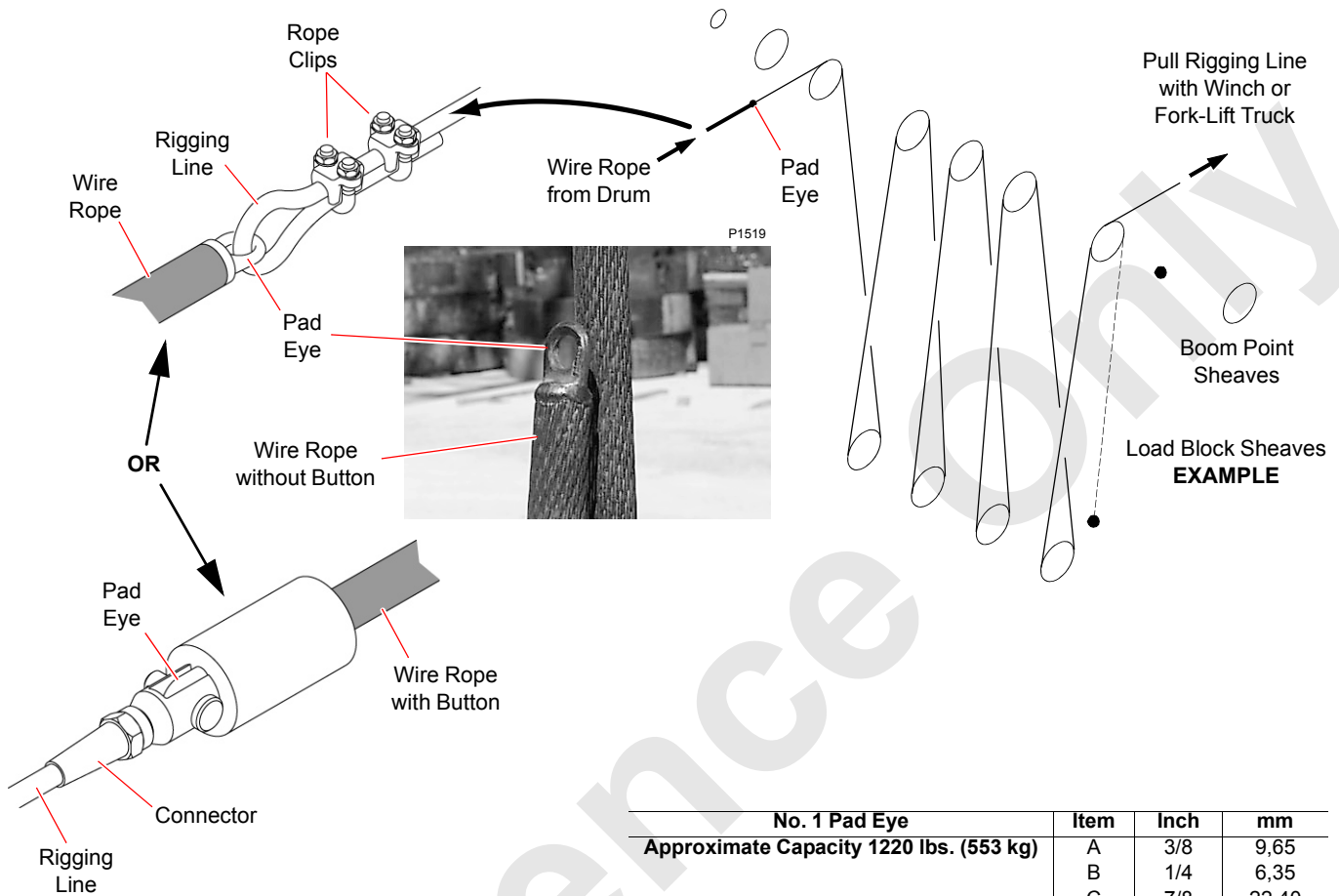

No. 1 Pad Eye			
Item	Inch	mm	
<b>Approximate Capacity 1220 lbs. (553 kg)</b>			
A	3/8	9,65	
B	1/4	6,35	
C	7/8	22,40	
D	13/32	10,40	
E	7/8	22,40	
F	1/8	3,30	
G	1-1/32	25,40	

No. 1.5 Pad Eye			
Item	Inch	mm	
<b>Approximate Capacity 1220 lbs. (553 kg)</b>			
A	5/8	16,00	
B	1/4	6,35	
C	1	25,40	
D	7/16	11,18	
E	1-1/8	28,70	
F	1/16	4,06	
G	1-5/16	33,27	

No. 2 Pad Eye			
Item	Inch	mm	
<b>Approximate Capacity 2600 lbs. (1179 kg)</b>			
A	3/4	19,05	
B	3/8	9,65	
C	1-1/16	26,92	
D	1/2	12,70	
E	1-1/2	38,10	
F	3/16	4,83	
G	1-5/8	41,26	

FIGURE 4-21

## Breaking in Wire Rope

After installing a new wire rope, break it in by operating it several times under light load at reduced speed. This practice allows the wire rope to form its natural lay and the strands to seat properly.

**NOTE** The wire rope will stretch during the break-in period, reducing the wire rope's diameter as the strands compact around the core.

The dead wraps of wire rope on the drum can become slack during operation, even if the utmost care is used during installation of the wire rope. This slackening is caused by the normal stretch that occurs in a new wire rope under tension and periodically throughout the wire rope's life from release of the load.

When slackness is noted, tightly wind the dead wraps of wire rope onto the drum. If left uncorrected, a wedging action with subsequent layers will occur, and the resultant abrasion may cause broken wires in the dead wraps.

## PAD EYE USAGE FOR WIRE ROPE REEVING

See [Figure 4-21](#)

### General

Some rotation-resistant wire rope supplied by Manitowoc is equipped with a No. 1.5 pad eye welded to the leading end of the wire rope or to the button on the end of the wire rope.

A rigging line can be attached to the pad eye to make it easier to reeve the load block.

### Safety

1. For the No. 1.5 pad eye, do not exceed 1,000 lb (4,45 kN) single line pull.
2. Make sure the rigging line and attaching hardware (clips and rope connectors) are rated for at least 1,000 lb (4,45 kN) line pull.
3. Inspect the pad eye prior to each use, replace if:
  - Any original dimensions have changed
  - Cracks or breaks exist in the metal or weld



### WARNING

#### Flying Part Hazard!

Pad eye on end of wire rope has been provided **for reeving purposes only**. Any other use is neither intended nor approved.

Pad eye can break and fly apart with considerable force if it is overloaded, not used properly, or not maintained properly.

14LOM4145

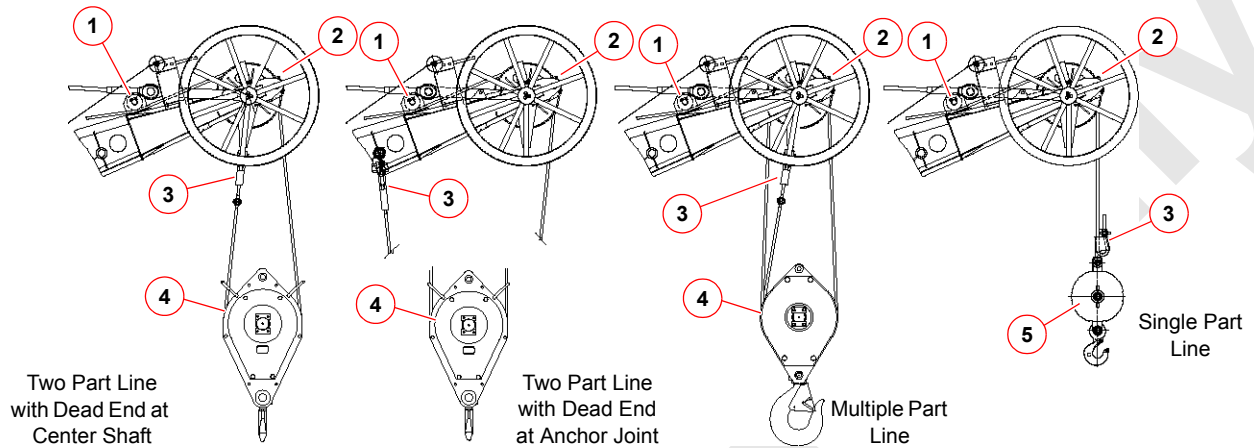

**WARNING**

**Avoid Death or Serious Injury!**

If you are using a load block that can be stood up vertically for reeving, exercise care, as the potential for tipping exists. Potential causes of tipping are unstable work area, boom or jib movement, and the reeving process.

If work area is unstable, lay load block flat on side plate.

Item	Description
1	Load Sensing Sheave
2	Luffing Jib Point
3	Dead End
4	Load Block
5	Hook and Weight Ball

FIGURE 4-22

## LOAD LINE REEVING

---



### WARNING

#### Falling Load Hazard!

Use only a load block or hook and weight ball with a capacity equal to or greater than load to be handled.

Load block can fail if overloaded, allowing load to fall.

---

### Load Block Identification

See the Luffing Jib Assembly Drawing at the end of this section for a complete list of load blocks and hook and weight balls available for use with the luffing jib.

### Wire Rope Specifications

See the Wire Rope Specifications Chart in the Capacity Chart Manual for the following load block reeving information:

- Parts of line required to handle desired load
- Wire rope length required for various boom lengths and parts of line
- Maximum spooling capacity of load hoists

### Wire Rope Installation

See the Wire Rope Installation topic on [page 4-30](#) of this section for instructions on:

- Installing wire rope on drums

- Anchoring wire rope to drums

See Wire Rope Lubrication in Section 5.

### Dead End Locations

See Figure [4-22](#) for the dead end locations.

### Guide Sheaves and Drums

See Figures [4-23](#) through [4-26](#) for identification of the load drums and the guide sheaves, and for proper rope routing up the boom and jib.

To ensure proper fleet angles, the wire rope must be routed as shown. **Wire rope can be damaged if not properly routed up the boom and jib.**

Once the wire rope is routed through the guide sheaves install all rope guard pins, bars, and rollers to retain the wire rope on the sheaves. **Wire rope and sheaves can be damaged if rope is not properly retained on sheaves.**

### Load Block Reeving

See Figures [4-23](#) through [4-26](#) for reeving diagrams. Reeving the load block in any manner other than shown can result in excessive block twist.

---

### CAUTION

#### Wire Rope Damage!

Do not hoist load block closer to boom point than shown on Range Diagram in Capacity Chart Manual. Improper fleet angle or contact with other parts can damage wire rope.

---

**Wire Rope Routing WITH DRUM 3 Option**

- Drum 3 to Luffing Jib Struts (see Luffing Jib Assembly Drawing for Reeving)
- Front Drum to Luffing Jib Point
- Rear Drum to Lower Boom Point OR Not Used

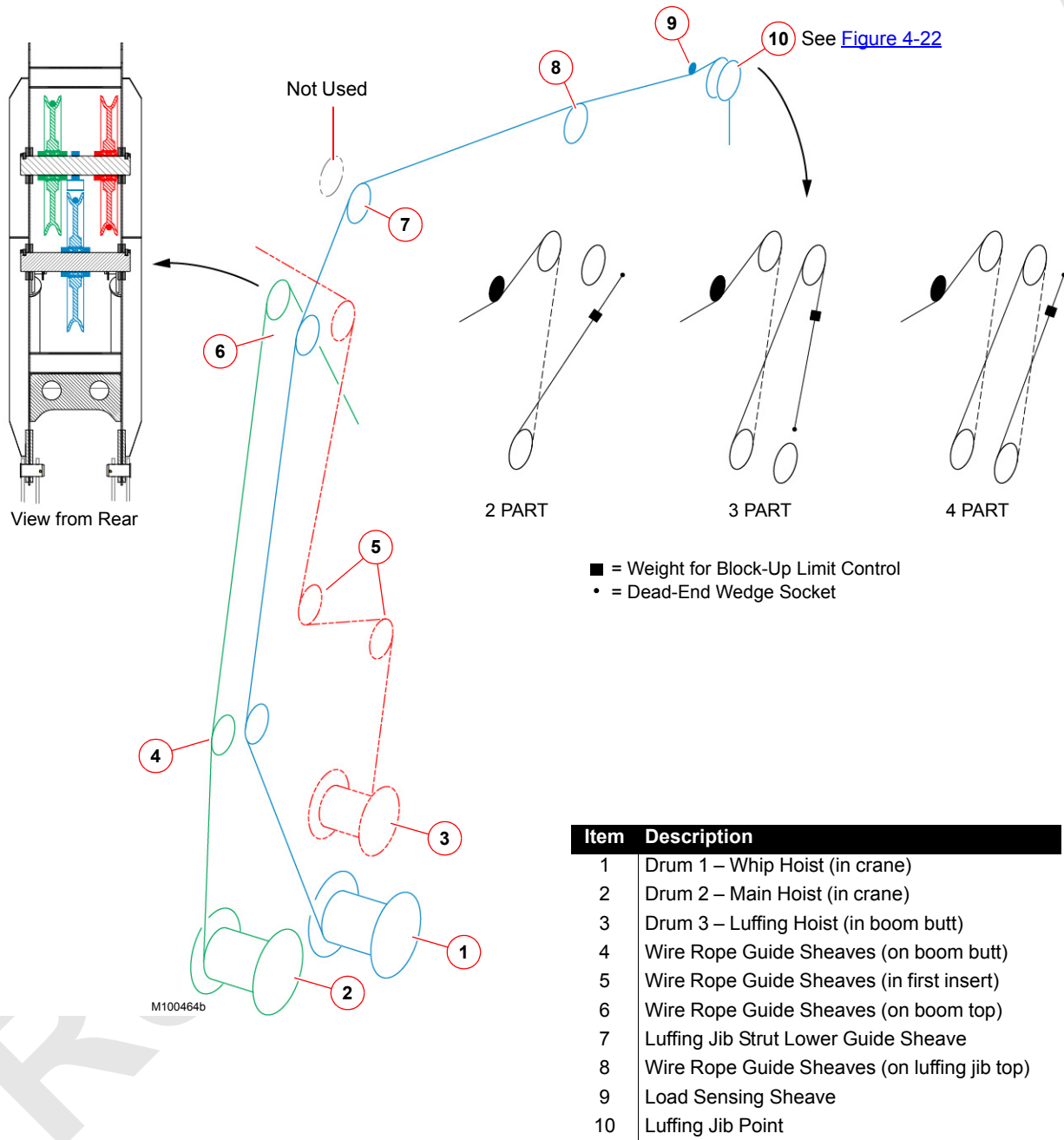

FIGURE 4-23

**Wire Rope Routing WITH DRUM 3 Option**

- Drum 3 to Luffing Jib Struts (see Luffing Jib Assembly Drawing for Reeving)
- Front Drum Not Used
- Rear Drum to Luffing Jib Point (over luffing jib strut UPPER guide sheave)

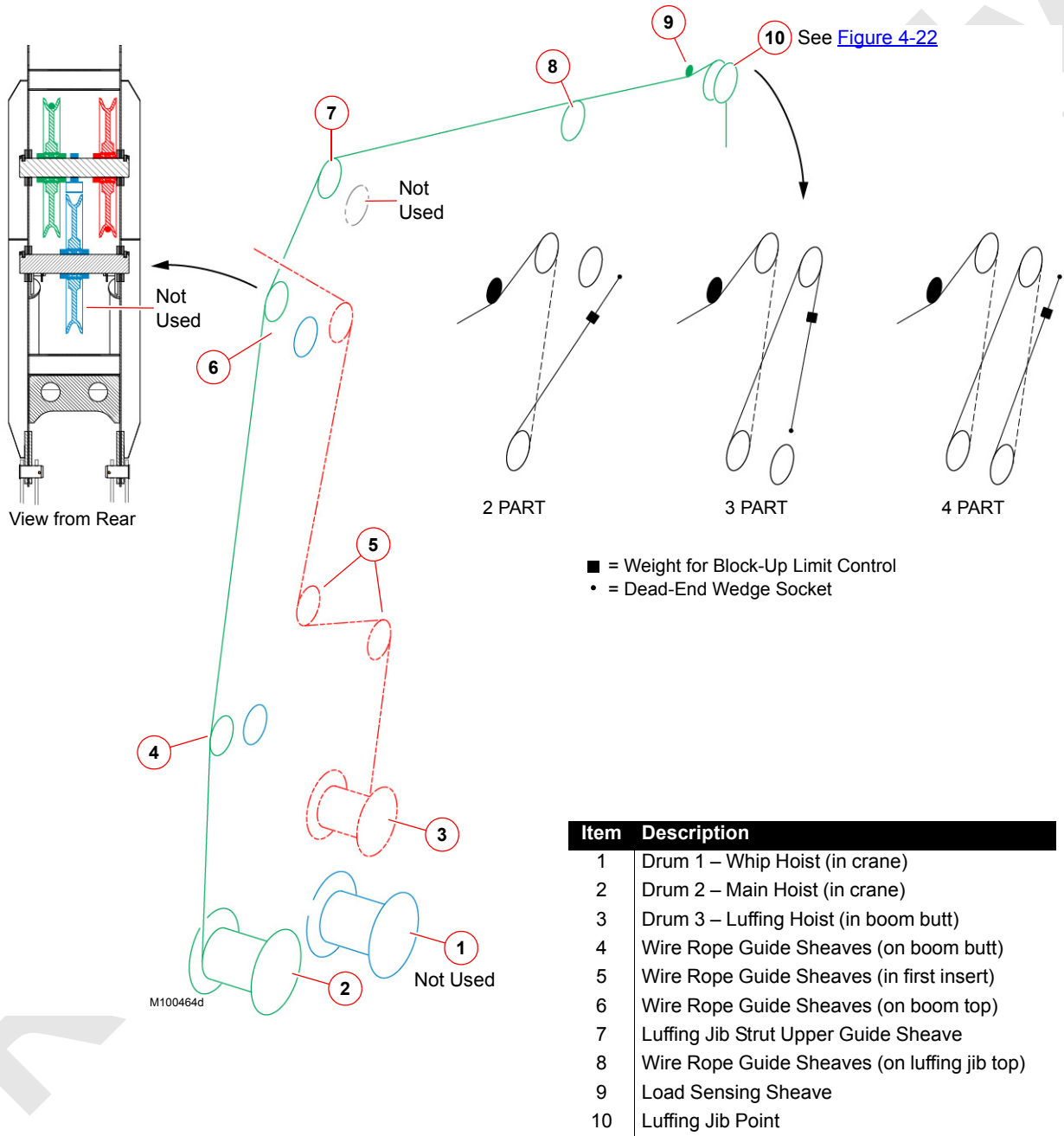

FIGURE 4-24

**Wire Rope Routing WITH DRUM 3 Option**

- Drum 3 to Luffing Jib Struts (see Luffing Jib Assembly Drawing for Reeving)
- Front Drum Not Used
- Rear Drum to Luffing Jib Point (over luffing jib strut LOWER guide sheave)

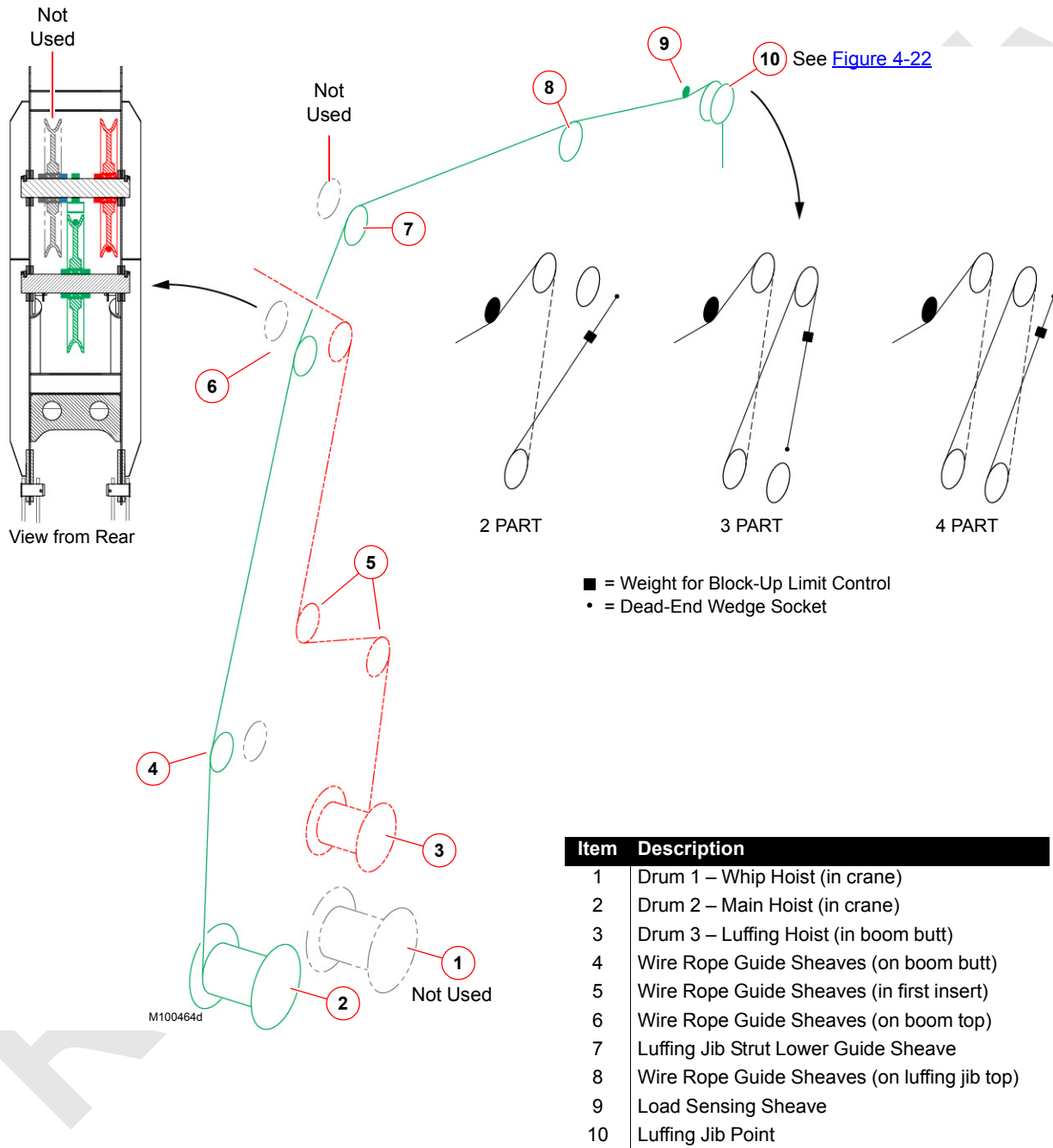

FIGURE 4-25



**Wire Rope Routing WITHOUT DRUM 3 Option**

- Front Drum to Luffing Jib Struts (see Luffing Jib Assembly Drawing for Reeving)
- Rear Drum to Luffing Jib Point

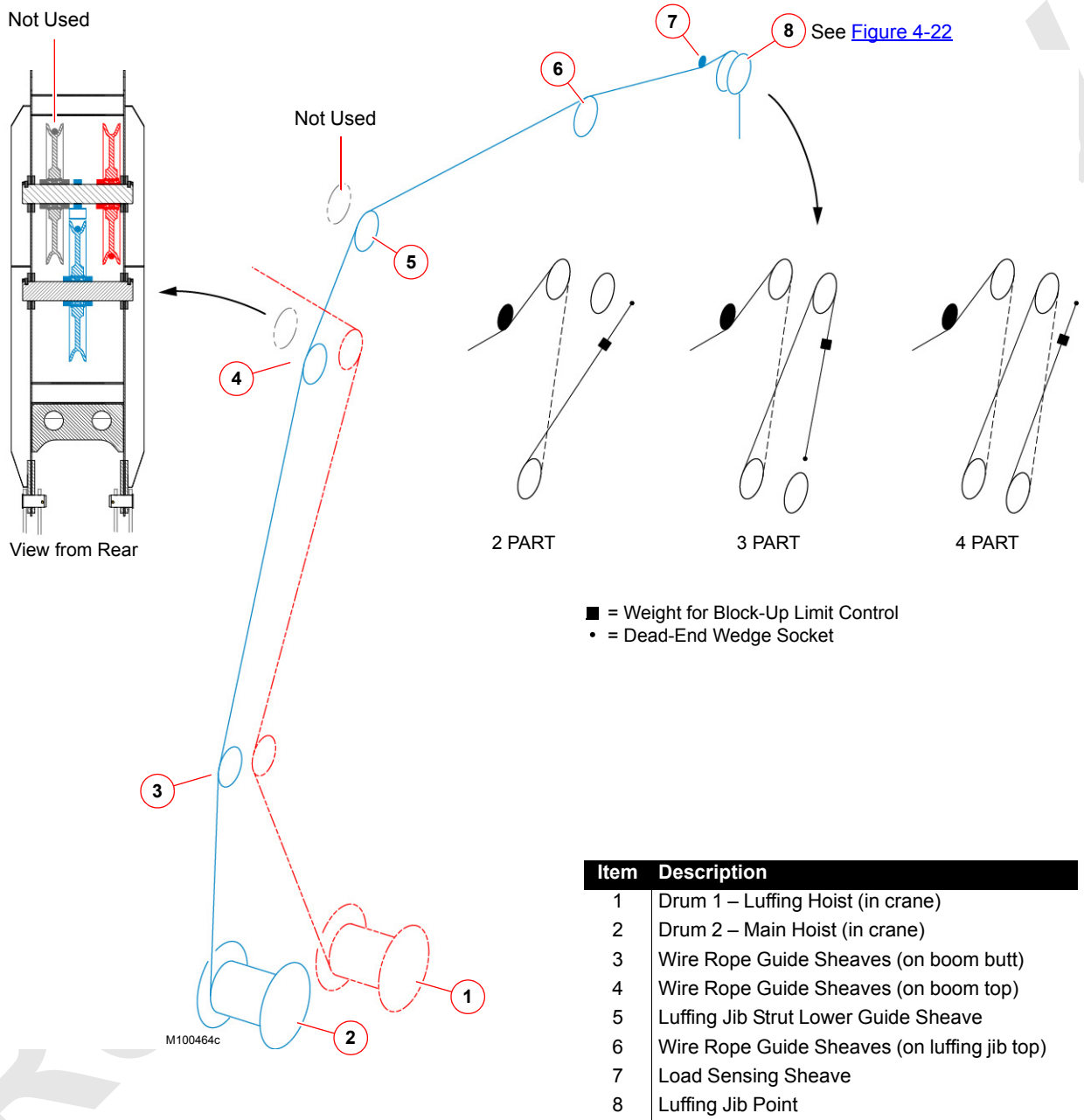

FIGURE 4-26

*THIS PAGE INTENTIONALLY LEFT BLANK*

# SECTION 5 LUBRICATION

## TABLE OF CONTENTS

Lubrication . . . . .	5-1
Lube and Coolant Product Guide . . . . .	5-1

Reference Only

*THIS PAGE INTENTIONALLY LEFT BLANK*

## SECTION 5 LUBRICATION

### LUBRICATION

See F2261 at the end of this section.

### LUBE AND COOLANT PRODUCT GUIDE

See the publication at the end of this section.

Reference Only

*THIS PAGE INTENTIONALLY LEFT BLANK*

## SECTION 6

### MAINTENANCE PROCEDURES

#### TABLE OF CONTENTS

General Maintenance .....	6-1
Boom and Luffing Jib Angle Indicator .....	6-1
Automatic Boom Stop .....	6-3
Automatic Boom Stop Maintenance .....	6-3
Automatic Boom Stop Adjustment .....	6-5
Automatic Boom Stop Actuator Rod Replacement .....	6-5
Physical Boom Stop .....	6-7
Physical Boom Stop Angles .....	6-7
Physical Boom Stop Operation .....	6-7
Physical Boom Stop Adjustment .....	6-7
Jib Stop .....	6-9
Jib Stop Angles .....	6-9
Jib Stop Maintenance .....	6-9
Jib Stop Pre-Erection Checks .....	6-9
Jib Max Up 2 Limit Check .....	6-9
Jib Max Down 2 Limit Check .....	6-9
Jib Stop Operational Checks .....	6-9
Jib Stop Actuator Rod Replacement .....	6-10
Block-Up Limit .....	6-13
Block-Up Limit Operation .....	6-13
Disconnecting Block-Up Limit Switches .....	6-15
Disconnecting Wind Speed Controller .....	6-15
Removing Luffing Jib .....	6-15
Block-Up Limit Maintenance .....	6-17
Block-Up Limit Adjustment .....	6-17

*THIS PAGE INTENTIONALLY LEFT BLANK*



## SECTION 6 MAINTENANCE PROCEDURES

### GENERAL MAINTENANCE

This section contains maintenance and adjustment instructions for the limit devices used with the luffing jib attachment.

For maintenance and inspection of the following components, see the Service Manual supplied with your crane:

- Wire Rope and Pendants
- Load Block and Weight Ball
- Boom and Jib

### BOOM AND LUFFING JIB ANGLE INDICATOR

See [Figure 6-1](#)

An angle sensor (3) is located inside the controller (2) mounted on the boom top and on the luffing jib top (1).

The boom and luffing jib angles are calibrated automatically by the crane's programmable controller as part of the load calibration procedure for the Rated Capacity Limiter/Indicator (RCL/RCI). Refer to the RCL/RCI Operation Manual for instructions.

When installing a new sensor (3), mount it in the controller at the specified angle.

Connect the electric wires from the sensor (3) to the specified terminals on the printed circuit board in the bottom of the controller.

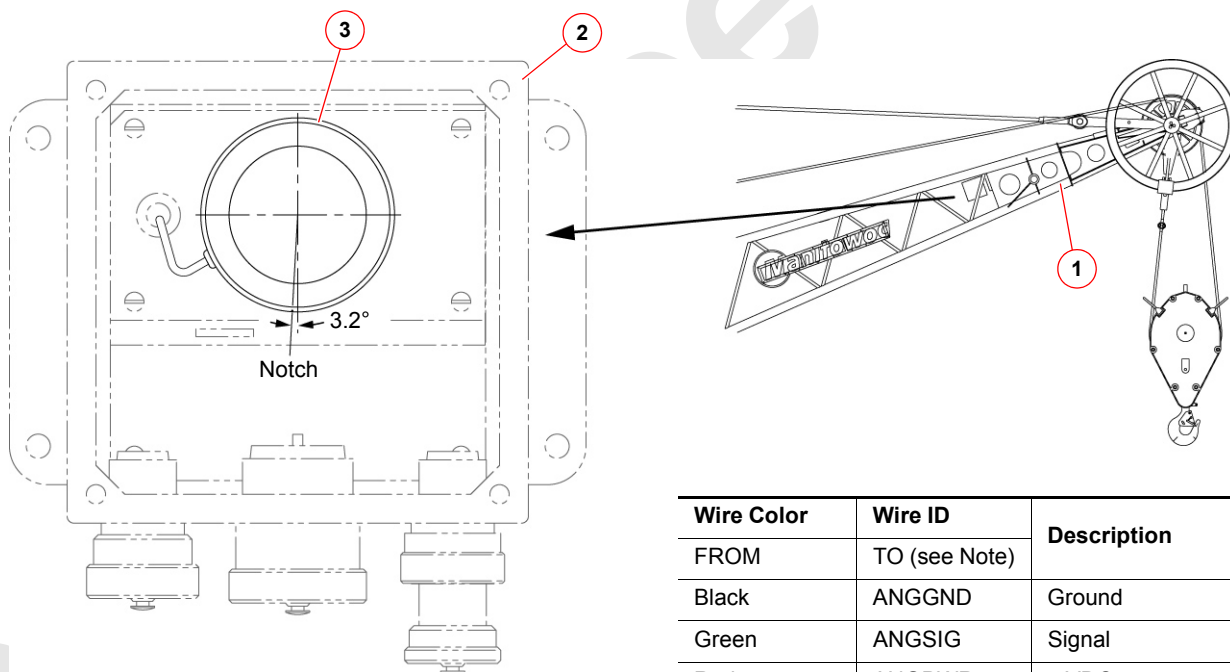

Item	Description
1	Luffing Jib Top
2	Controller
3	Sensor

Wire Color	Wire ID	Description
FROM	TO (see Note)	
Black	ANGGND	Ground
Green	ANGSIG	Signal
Red	ANGPWR	5 VDC
White	Not Used	

**NOTE** Wires go to terminals on printed circuit board in bottom of controller.

FIGURE 6-1

*THIS PAGE INTENTIONALLY LEFT BLANK*

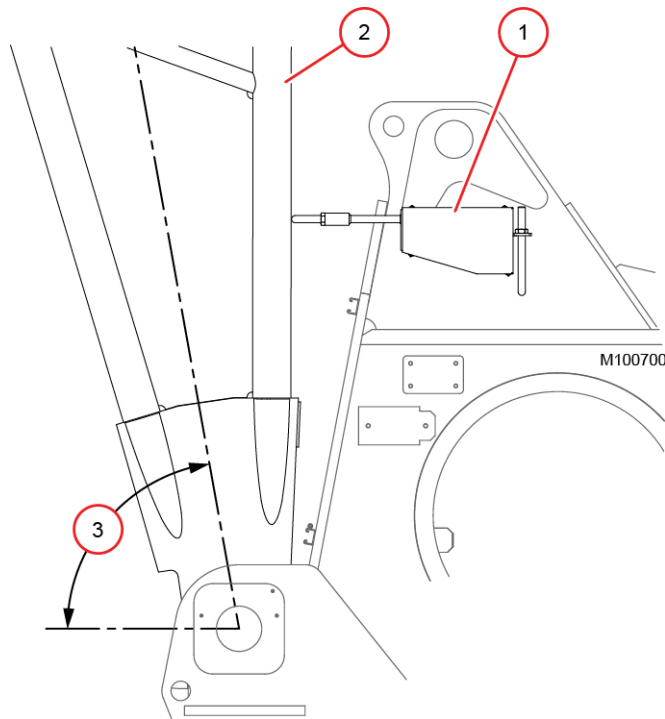

Item	Description
1	Limit Switch Assembly
2	Boom Butt
3	Maximum boom angle: 82.7° without Luffing Jib 88.0° with Luffing Jib

FIGURE 6-2

## AUTOMATIC BOOM STOP

The automatic boom stop limit switch assembly (1, [Figure 6-2](#)) automatically stops the boom (2) and applies the boom hoist brake if the boom is raised to the maximum boom angle (3).



### WARNING

#### Falling Attachment Hazard

Do not operate the crane unless the automatic boom stop is properly adjusted and operational. Do not adjust the maximum operating angle higher than specified. The boom could be pulled over backwards or collapse, causing death or serious injury.

When the maximum boom angle is reached, the fault alarm comes on and the boom maximum up icon appears in the information screen of the main display.

To correct the fault once it is activated, lower the boom. The fault cannot be bypassed.



### Automatic Boom Stop Maintenance

At least once weekly, check that the automatic boom stop stops the boom at the specified maximum boom angle. If it doesn't, replace any worn or damaged parts and/or adjust the automatic boom stop.

The automatic boom stop angle must be readjusted each time the luffing jib is installed or removed.

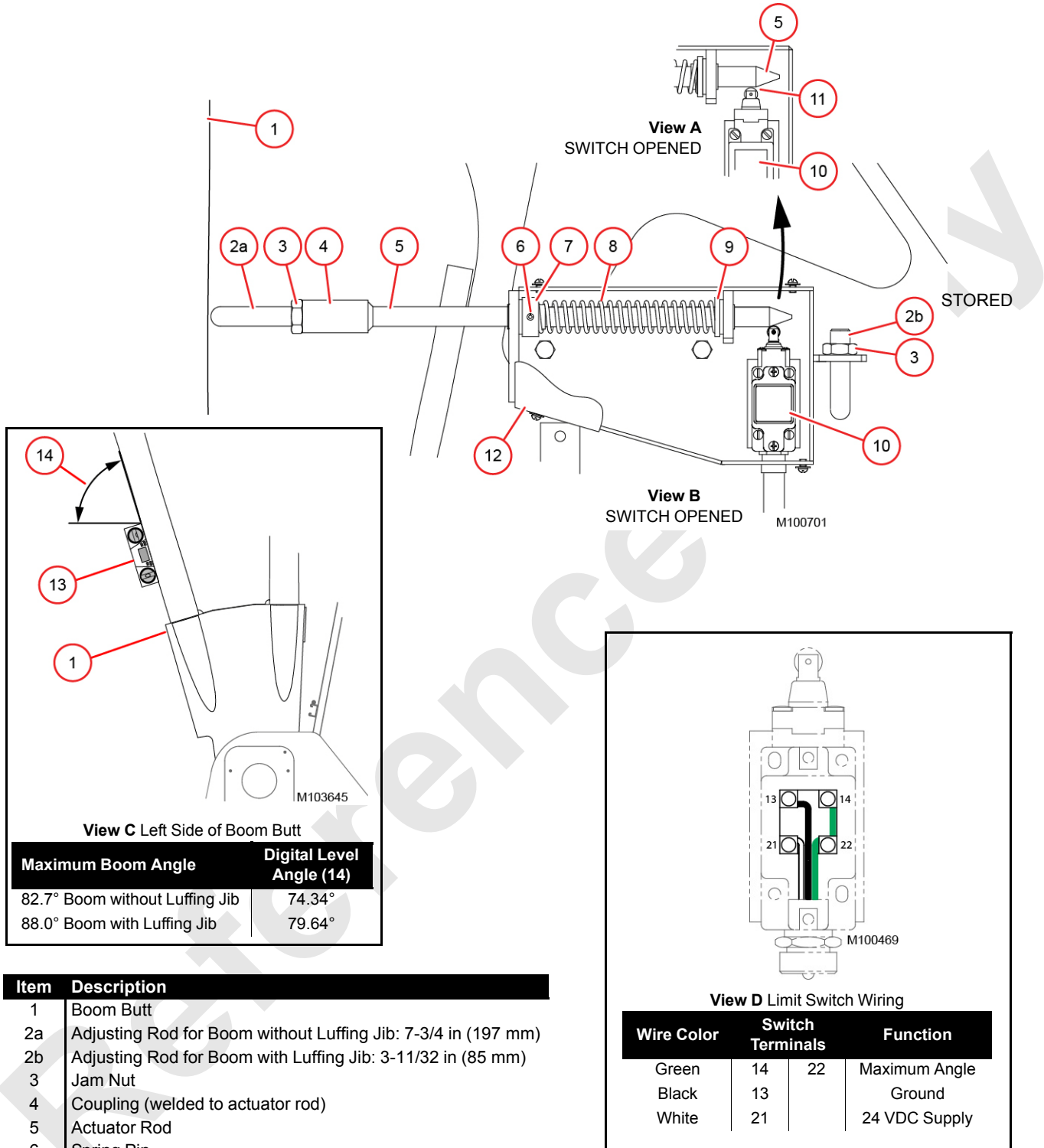

FIGURE 6-3

## Automatic Boom Stop Adjustment

See [Figure 6-3](#) for the following procedure.

The limit switch for the automatic boom stop was set at the factory and should not require periodic adjustment. Adjustment is necessary when:

- Parts are replaced
- The boom is operated with luffing jib removed
- The boom is operated with luffing jib installed

The following procedure assumes that the Rated Capacity Limiter/Indicator (RCL/RCI) is installed and properly calibrated.

During the following procedure, the boom angle is monitored on the RCL/RCI working screen and on a digital protractor-level (13, View C).

1. Park the crane on a firm level surface or level the crane by blocking under the crawlers.
2. Check that the proper adjusting rod (2a or 2b) is installed:
  - Rod (2a) for boom without luffing jib
  - Rod (2b) for boom with luffing jib
3. Boom up slowly while monitoring the boom angle on the RCL/RCI working screen.
4. Stop booming up when the boom reaches the specified maximum boom angle given in the table for View C.
 

Verify the boom angle with an accurate digital protractor-level (13) placed on the boom butt bottom chord as shown in View C. The specified digital level angle (14) should appear on the protractor-level.

  - If the boom stops at the specified angle, further adjustment is not needed.
  - If the boom stops before reaching the specified angle, go to step 5.
  - If the boom reaches the specified angle before it stops, go to step 6.
5. If the boom stops before reaching the specified angle:
  - a. Loosen the jam nut (3, View B).
  - b. Turn the adjusting rod (2a or 2b) all the way into the coupling (4).
  - c. Boom up slowly until the boom reaches the specified angle and stop.
  - d. Turn the adjusting rod (2a or 2b) out against the boom butt (1) until the limit switch (10) "CLICKS" open.
  - e. Tighten the jam nut (3).
6. If the boom reaches the specified angle before it stops:
  - a. Boom up slowly until the boom reaches the specified angle and stop.
  - b. Loosen the jam nut (3, View B).
  - c. Turn the adjusting rod (2a or 2b) out against the boom butt (1) until the limit switch (10) "CLICKS" open.
  - d. Tighten the jam nut (3).
7. Check that the actuator rod (6) over-travels the limit switch as shown in View A.
8. Boom down and then back up. The boom must stop at the specified maximum boom angle.
9. If the boom fails to stop, repeat [step 3](#) through [step 8](#).

## Automatic Boom Stop Actuator Rod Replacement

See [Figure 6-3](#) for the following procedure.

1. Park the crane on a firm level surface or level the crane by blocking under the crawlers.
2. Remove the damaged or incorrect actuator rod (5).
3. Slide the spring washers (7 and 9) and spring (8) over the new actuator rod (5) while sliding the new actuator rod into the bracket assembly.
4. Position the actuator rod (5) so the tapered end just contacts the roller on limit switch (10). The actuator rod must not depress the limit switch roller.
5. Drill a 1/4 in (6 mm) hole through the spring washer (9) and the actuator rod (5).
6. Install the spring pin (6).
7. Install the proper adjusting rod (2a or 2b) and perform Automatic Boom Stop Adjustment procedure.

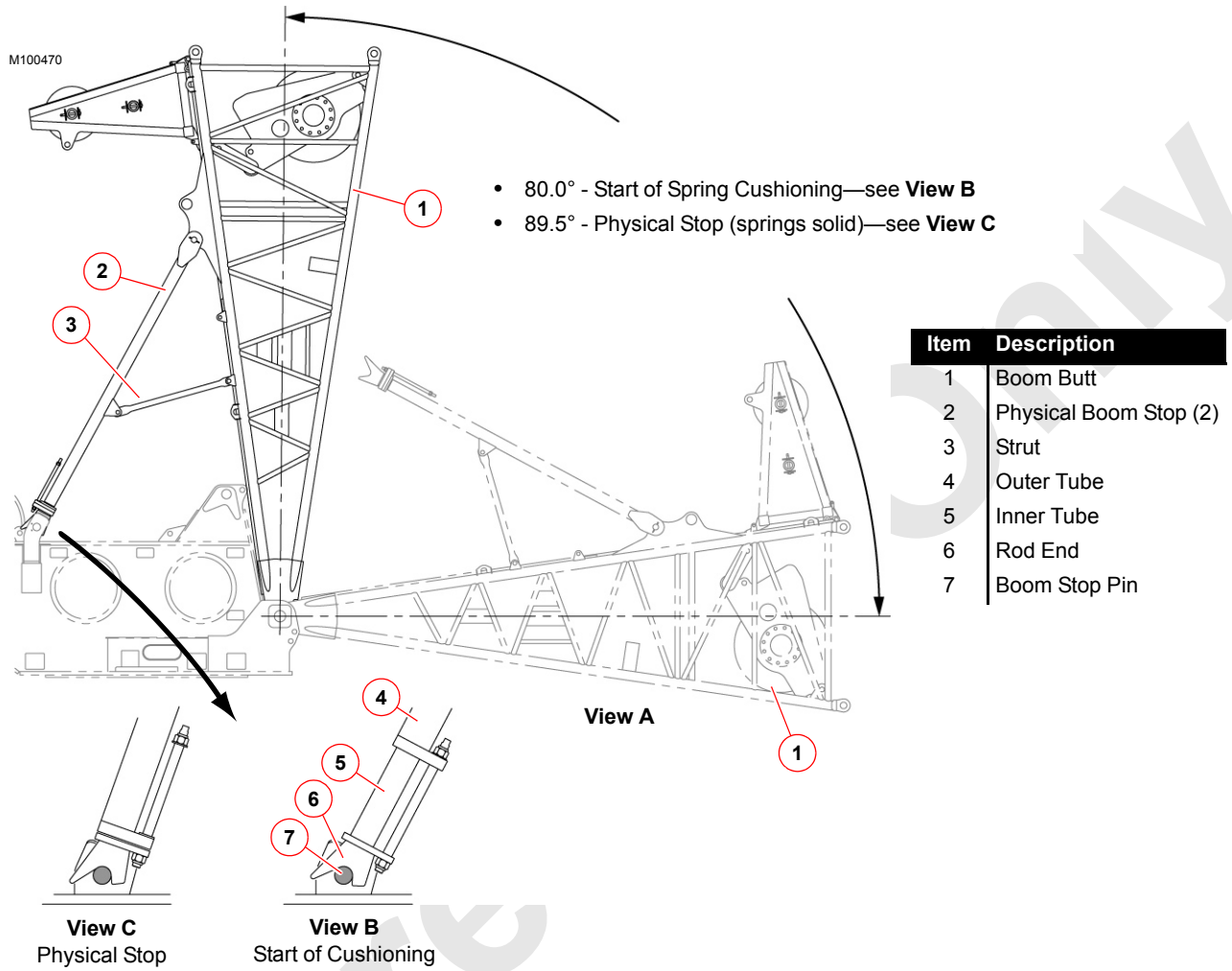

FIGURE 6-4

## PHYSICAL BOOM STOP

See [Figure 6-4](#)



### WARNING

#### Collapsing Boom Hazard!

Physical boom stops must be installed for all crane operations.

Physical boom stops do not automatically stop boom at maximum operating angle.

Automatic boom stop must be installed and properly adjusted.

---

### Physical Boom Stop Angles

Physical boom stops (2, View A) serve the following purposes:

- Assist in stopping the boom smoothly at any angle above 80°.

- Assist in preventing the boom rigging from pulling the boom back when traveling or setting loads with the boom at any angle above 80°.
- Assist in moving the boom forward when lowering the boom from any angle above 80°.
- Provide a physical stop at 89.5°.

### Physical Boom Stop Operation

- When the boom is raised to 80°, the springs in the boom stop tubes start to compress (View B).
- As the boom is raised higher, spring compression increases to exert greater force against the boom.
- If for any reason the boom is raised to 89.5°, the boom stop springs fully compress to provide a physical stop (View C).

### Physical Boom Stop Adjustment

Struts (3) have slotted ends that do not require adjustment.

Item	Description	Deactivated	Activated
<b>D1</b>	Edge of Actuator Rod to Edge of Limit Switch Housing	15.18 in (385,6 mm)	14.91 in (378,7 mm)
<b>D2</b>	Edge of Actuator Rod to Front Edge of Jib Stop Mounting Bracket	6.07 in (154,2 mm)	5.84 in (148,4 mm)

Item	Description
<b>A1</b>	Jib Max Up 2 Angle = 171°
<b>A2</b>	Jib Max Down 2 Angle = 57°

Item	Description
1	Limit Switch - Max Up 2
1a	Actuator Rod
2	Limit Switch - Max Down 2
2a	Actuator Rod
3	Luffing Jib Butt
4	Boom Top
5	Boom Top Controller

Only

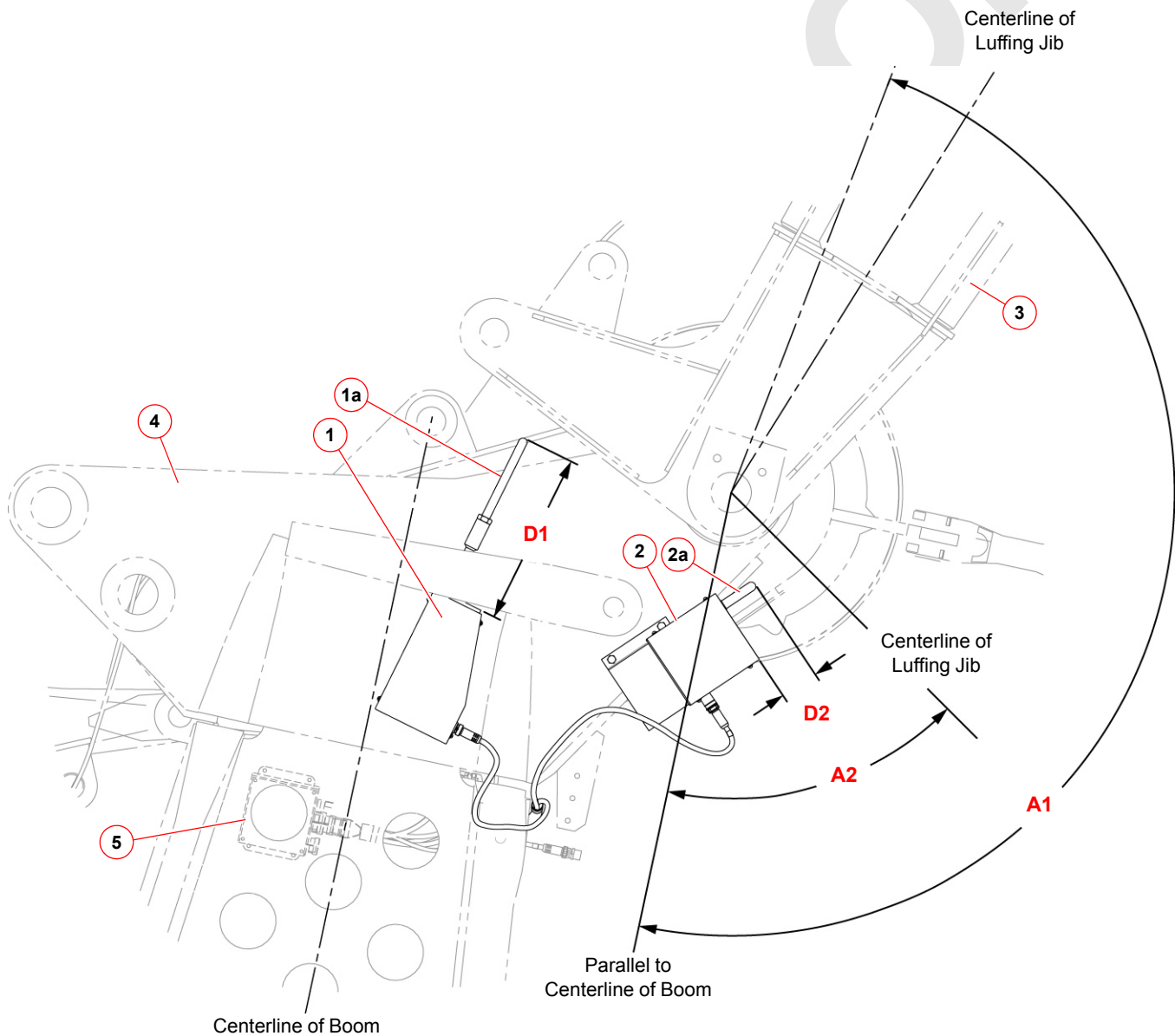

FIGURE 6-5



## JIB STOP

See [Figure 6-5](#)



### WARNING

#### Falling Attachment Hazard!

Do not operate crane unless luffing jib stops are properly adjusted and operational.

Operating luffing jib above Jib Max Up 2 Limit or below Jib Max Down 2 Limit is neither intended nor approved. Luffing jib can be pulled over backwards or collapse.

## Jib Stop Angles

The luffing jib attachment is equipped with two limits in both directions which automatically stop the luffing hoist and apply its brake when the luffing jib is raised or lowered to the following angles:

**NOTE** The luffing jib angles given in this section can vary plus or minus 1°.

- **Jib Max Up 1** (maximum working angle) – 168° boom to luffing jib angle. This is a programmed limit controlled by the crane's programmable controller in conjunction with signals from the boom and jib angle sensors.  
This limit can be bypassed, allowing the luffing jib to be raised an additional 3° to the Jib Max Up 2 limit.
- **Jib Max Up 2** (maximum angle limit) – 171° boom to luffing jib angle. This limit is controlled by limit switch (1).
- **Jib Max Down 1** (minimum working angle) – 60° boom to luffing jib angle. This is a programmed limit controlled by the crane's programmable controller in conjunction with signals from the jib angle sensor.
- **Jib Max Down 2** (minimum angle limit) – 57° minimum limit switch is provided as a backup to stop the luffing jib if the programmed minimum limit fails. This limit is controlled by limit switch (2).

## Jib Stop Maintenance

At least once weekly, and each time the attachment is erected, check that the luffing jib stops at the specified angles.

## Jib Stop Pre-Erection Checks

To ensure proper operation of the luffing jib stops:

- The luffing jib stop limit switches must be mounted properly.
- The electric cables from the jib stop limit switch must be connected to the proper receptacles in boom top controller (5). See the wiring diagram on [page 6-14](#).

- The luffing jib angles must be properly calibrated. See the RCL/RCI Operation Manual for instructions.

### Jib Max Up 2 Limit Check

Perform the following steps with the boom and luffing jib on the ground:

1. Check Dimension **D1** and if necessary, adjust actuator rod (1a) to obtain the specified deactivated dimension.

Perform the remaining steps with the engine running and the required Luffing Jib Capacity Chart selected in the RCL/RCI configuration screen.

2. Push actuator rod (1a) in to activated Dimension **D1** and hold. Listen for the limit switch to “click” open.
3. Pull the luffing jib control handle back.

The luffing hoist must not turn in the up direction and the Jib Max Up 2 fault must come on.

### Jib Max Down 2 Limit Check

Perform the following steps with the boom and luffing jib on the ground:

1. Check Dimension **D2** and if necessary, adjust the position of the limit switch housing to obtain the specified deactivated dimension.

Perform the remaining steps with the engine running and the required Luffing Jib Capacity Chart selected in the RCL/RCI configuration screen.

2. Push actuator rod (2a) in to activated Dimension **D2** and hold. Listen for the limit switch to “click” open.
3. Push the luffing jib handle forward.

The luffing hoist must not turn in the down direction and the Jib Max Down 2 fault must come on.

## Jib Stop Operational Checks

Make the following operational checks after the boom and jib are raised.

1. Travel the crane onto a firm level surface or level the crane by blocking under the crawlers.
2. Raise the boom and luffing jib until the boom is at 80°.
3. Monitor the BOOM TO LUFFING JIB ANGLE on the main display information screen while performing the remaining steps.
4. SLOWLY raise the luffing jib.
5. The luffing hoist must stop and be inoperable in the up direction when the boom to luffing jib angle is 168°.
6. The fault alarm should come on indicating that the Jib Max Up 1 angle has been reached.

7. Turn the limit bypass key switch clockwise to bypass the Jib Max Up 1 angle.

**WARNING****Falling Attachment Hazard!**

Watch that physical jib stop pendants do not become tight before Jib Max Up 2 limit switch is activated.

Jib can be pulled over backwards or collapse.

8. SLOWLY raise the luffing jib past the Jib Max Up 1 limit.
9. The luffing hoist must stop and be inoperable in up direction when the boom to luffing jib angle is 171°.
10. The fault alarm should come on indicating the Jib Max Up 2 limit has been reached.

***Troubleshoot the system if the jib up limits do not operate properly.***

11. SLOWLY lower the luffing jib.
12. The luffing hoist must stop and be inoperable when the boom to luffing jib angle is 60°.
13. The fault alarm should come on indicating the Jib Max Down 1 angle has been reached.
14. Turn the limit bypass key switch clockwise to bypass the Jib Max Down 1 angle and continue to lower the luffing jib.

15. The luffing hoist must stop and be inoperable in down direction when boom to luffing jib angle is 57°.

16. The fault alarm should come on indicating the Jib Max Down 2 angle has been reached.

***Troubleshoot the system if the jib down limits do not operate properly.***

**Jib Stop Actuator Rod Replacement**

See [Figure 6-6](#)

1. If equipped, remove adjusting rod (1) and lock nut (2).
2. Remove damaged actuator rod (3a or 3b).
3. Slide spring washers (5 and 7) and spring (6) over new actuator rod (3a or 3b) while sliding the actuator rod into the limit switch bracket.
4. Position actuator rod (3a or 3b) so the tapered end of the rod just touches limit switch (6) roller (View A). **The actuator rod must not depress the limit switch roller.**
5. Drill a 1/4 in (6,35 mm) hole through spring washer (5) and actuator rod (3a or 3b).
6. Install dowel pin (4).
7. If equipped, install adjusting rod (1) and lock nut (2). Adjust the rod to deactivated Dimension **D1** ([Figure 6-5](#)).

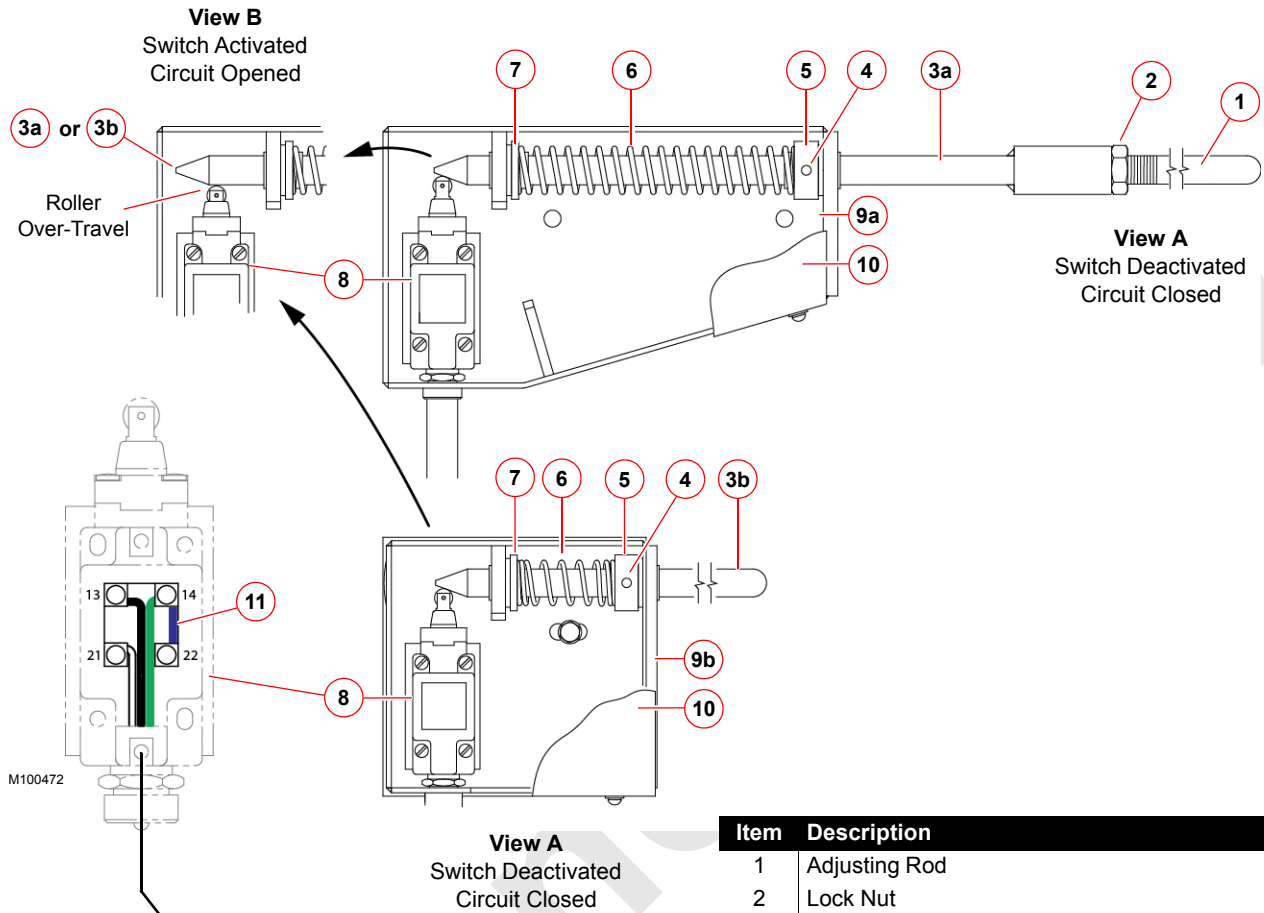

**Limit Switch Wiring**

Wire ID	Switch Terminals		Function
1 (green)	22	14	Max Angle
2 (black)		13	GND
3 (white)	21		28 VDC Supply

Item	Description
1	Adjusting Rod
2	Lock Nut
3a	Actuator Rod (Jib Max Up 2 Limit Switch)
3b	Actuator Rod (Jib Min Down 2 Limit Switch)
4	Spring Washer
5	Dowel Pin 1/4 in (6,35 mm) Diameter
6	Spring
7	Spring Washer
8	Limit Switch
9a	Limit Switch Assembly—Jib Max Up 2 Limit
9b	Limit Switch Assembly—Jib Max Down 2 Limit
10	Cover
11	Jumper Wire (Blue)

FIGURE 6-6

M100473

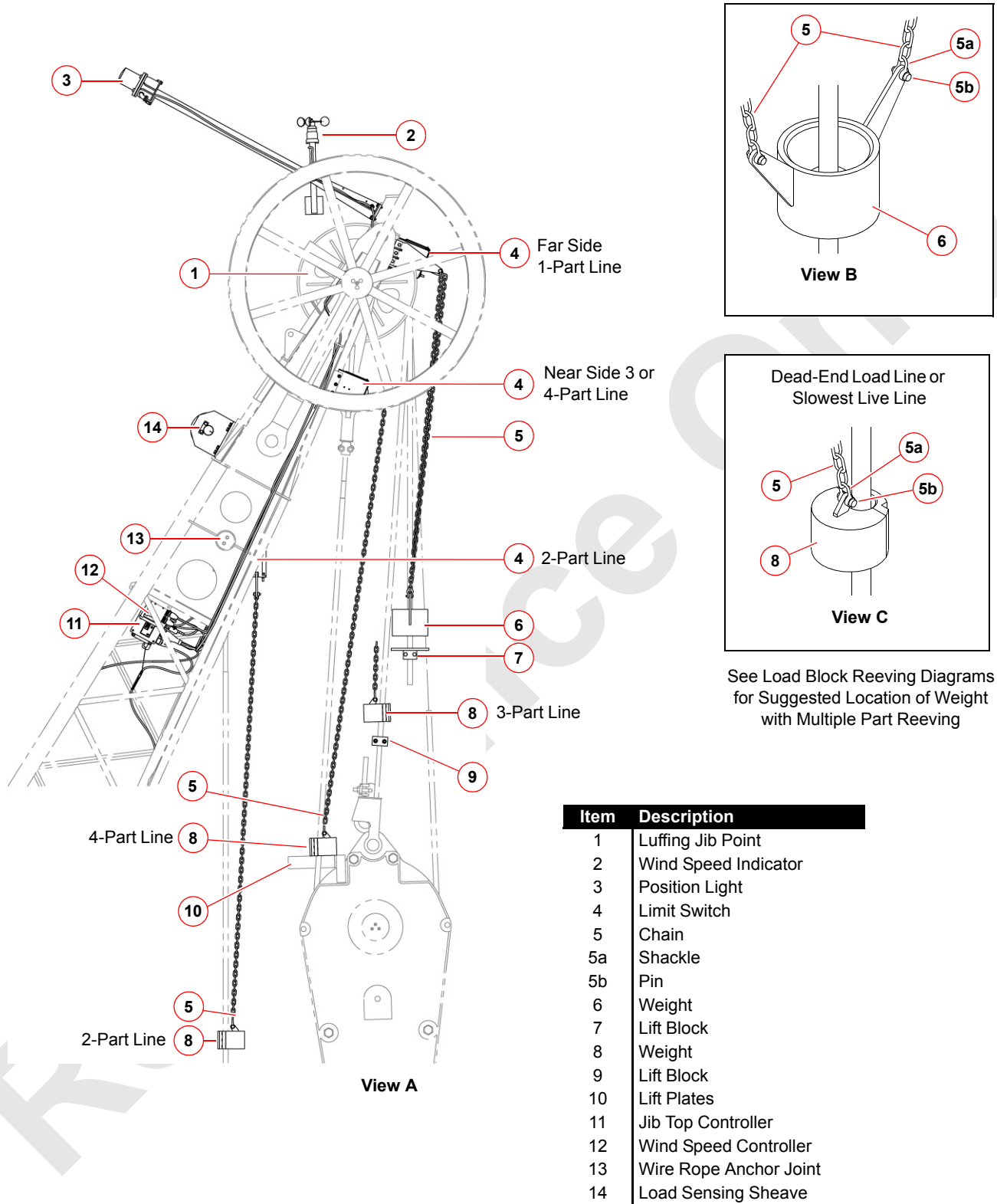

FIGURE 6-7

## BLOCK-UP LIMIT

---



### WARNING

#### Two-Blocking Hazard!

Block-up limit control is a protective device designed only to assist operator in preventing a two-blocking condition; any other use is neither intended nor approved.

Block-up limit control may not prevent two-blocking when load is hoisted at maximum single line speed. Operator must determine fastest line speed that allows block-up limit control to function properly and, thereafter, not exceed that line speed.

---

### Block-Up Limit Operation

The block-up limit control (also called anti two-block device) is a two-blocking prevention device which automatically stops the load drum from hoisting and the luffing jib from lowering when the load is hoisted a predetermined distance from the luffing jib point.

DEFINITION: Two-blocking is the unsafe condition in which the load block or the weight ball contacts the sheave assembly from which either is suspended.

**Two-blocking can result in failure of sheaves and wire rope, possibly causing load to fall.**

The block-up limit system consists of the following components ([Figure 6-7](#)):

- Jib top controller
- Normally closed limit switch assembly fastened at the locations shown
- Weight freely suspended by chain from each limit switch actuating lever (weight encircles load line as shown)
- Lift block fastened to the load line or lift plates fastened to the load block
- Cable reel in the jib butt (not shown) which allows the cable to be lengthened or shortened to meet varying jib lengths

To ensure proper operation of the components in the luffing jib point, the electric cables must be connected properly ([Figure 6-8](#)).

For identification and location of the block-up limit components in the boom, see the Operator and Service Manuals supplied with the crane.

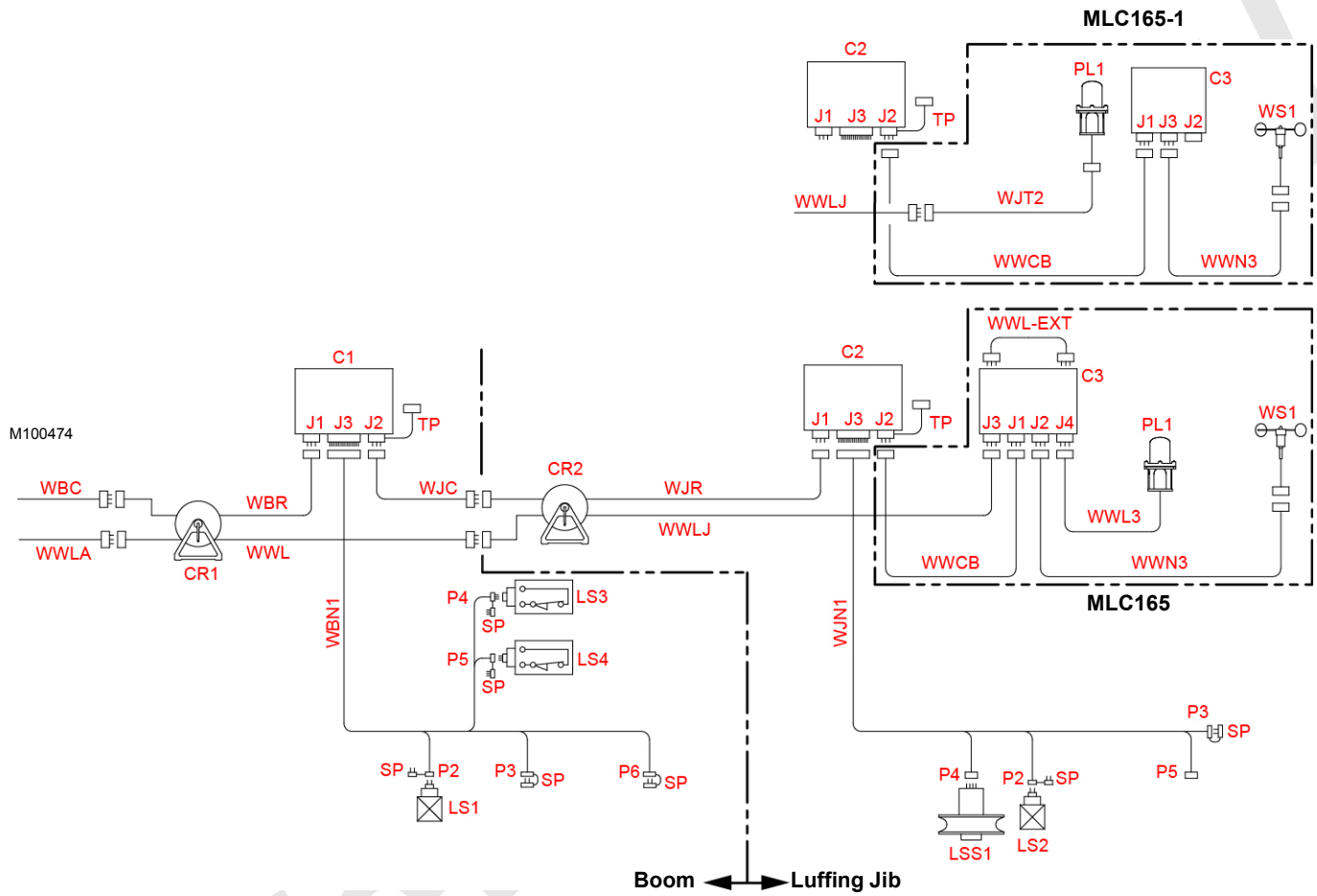

FIGURE 6-8

Legend for [Figure 6-8](#)

Item	Description	Item	Description
<b>SEALING CAPS</b>		<b>LIMIT SWITCHES</b>	
1	Dust Cap	LS1	Block-Up, Lower Boom Point
<b>CABLES</b>		LS2	Block-Up, Luffing Jib Point
WBC	From Engine Node	LS3	Max Up 2 Limit, Luffing Jib
WWLA	From Cab	LS4	Max Down 2 Limit, Luffing Jib
WBR	From Boom Butt Cable Reel	<b>LOAD SHEAVES</b>	
WWL	From Boom Butt Cable Reel	LSS1	Load Sensing Sheave, Luffing Jib Point)
WWL-EXT	Cranes without Wind Speed Controller	<b>PLUGS, BOOM</b>	
WJC	To Luffing Jib Butt Cable Reel	P2	Block-Up Limit Switch, Lower Boom Point
WBN1	To Boom Top	P3	Not Used
WJR	From Luffing Jib Butt Cable Reel	P4	Max Up Limit 2, Luffing Jib
WJT2	From Position Light (MLC165-1 only)	P5	Max Down Limit 2, Luffing Jib
WWLJ	From Luffing Jib Butt Cable Reel	P6	Not Used
WJN1	To Luffing Jib Top	<b>PLUGS, LUFFING JIB</b>	
WWCB	To Wind Speed Controller	P2	Block-Up Limit Switch, Lower Luffing Jib Point
WWL3	To Jib Top Position Light	P3	Not Used
WWN3	To Jib Top Wind Speed Indicator	P4	Load Sensing Sheave, Luffing Jib Point
<b>CABLE REELS</b>		P5	Not Used
CR1	Boom Butt	<b>PLUGS, SHORTING/TERMINATING</b>	
CR2	Luffing Jib Butt	SP	Plug, Shorting
<b>CONTROLLERS</b>		TP	Plug, Terminating
C1	Boom Top	<b>WIND SPEED INDICATOR</b>	
C2	Luffing Jib Top	WS1	Wind Speed Indicator, Luffing Jib Top
C3	Wind Speed		
<b>LIGHTS</b>			
PL1	Position Light, Luffing Jib Top		

**Failing to perform the following steps when disconnecting components will prevent the load drums from hoisting and the boom and luffing jib from lowering. Also, the fault alarm will come on.**

## Disconnecting Block-Up Limit Switches

See [Figure 6-8](#)

- To ensure proper operation, connect a shorting plug (SP) to the end of any electric cable that is disconnect from a limit switch (LS1, 2, 3, or 4).
- Always connect sealing caps to the ends of cables, to receptacles, and to shorting plugs that are not being used.

## Disconnecting Wind Speed Controller

See [Figure 6-8](#)

Connect terminating plug (TP) to receptacle (J2) if electric cable WWCB is disconnected from jib top controller (C2).

## Removing Luffing Jib

See [Figure 6-8](#)

- Disconnect electric cables (WJC and WWL) from the luffing jib cable reel (CR2)
- Reconnect the electric cables to the proper receptacles in the boom top. See the Electric Control Assembly, Boom Wiring and Limits at the end of Section 4.
- If necessary, connect terminating plug (TP) to receptacle (J2) in boom top controller (C1).
- Disconnect electric cable (WJR) from luffing jib top controller (C2).
- Disconnect electric cable (WWLJ) from wind speed controller (C3) for the MLC165 or from electric cable (WJT2) for the MLC165-1.
- Connect sealing caps to the ends of all disconnected cables and receptacles.
- Coil the electric cables onto jib butt cable reel (CR2).

A1007

Limit Switch Wiring	
Wire	Switch Terminals
Black	21
White	22

Item	Description
1	Limit Switch
2	Cover
3	Shaft
4	Limit Switch Lever
5	Roller
6	Actuating Lever
7	Grease Fitting
8	Adjusting Screw
9	Enclosure
10	Spring
11	Set Screw
12	Elbow with Cord Griper
13	From Jib Node Controller

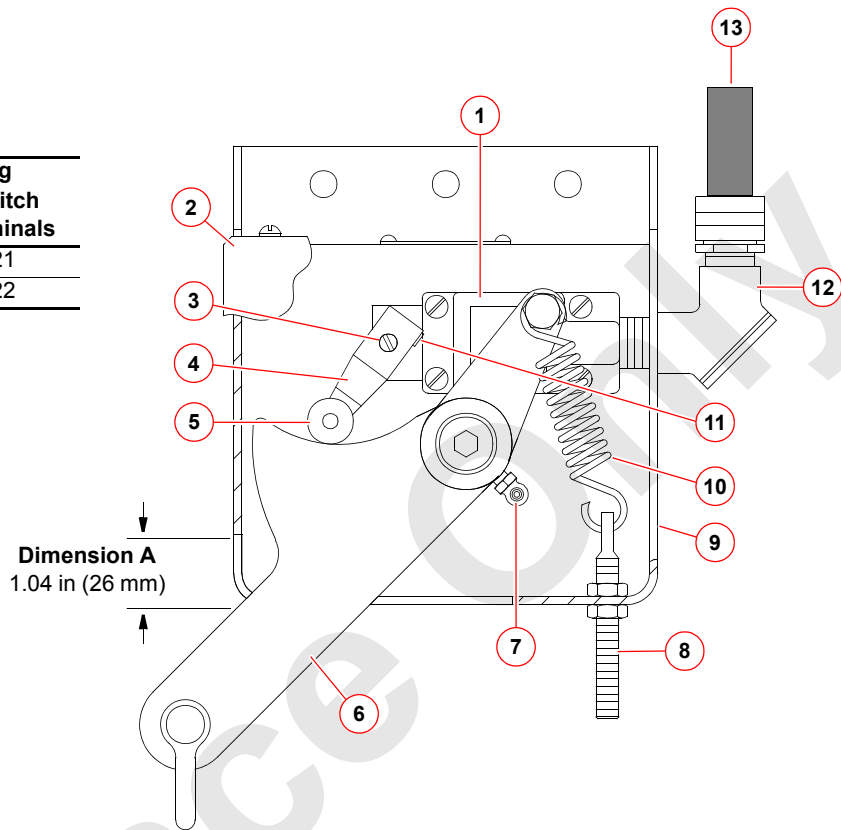

FIGURE 6-9



## Block-Up Limit Maintenance

### CAUTION

#### Prevent Damage!

To prevent two-blocking from occurring, do not operate crane until cause for improper operation and all hazardous conditions have been found and corrected.

**At least once weekly**, inspect and test the block-up limit switches.

1. Lower the boom onto blocking at ground level and carefully inspect the following items:
  - a. Inspect each limit switch lever and actuating lever (Figure 6-9) for freedom of movement. Apply one-half shot of grease to the fitting in the actuating lever. Wipe away any excess grease.
  - b. Inspect each weight (Figure 6-7) for freedom of movement on the load line.
  - c. Inspect each weight, each chain, each shackle, and each connecting pin (Figure 6-7) for excessive or abnormal wear. Make certain cotter pins for shackles are installed and spread.
  - d. Inspect the entire length of the electric cables for damage.
  - e. Check that the electric cables are clear of all moving parts on the boom and the luffing jib and that the cables are securely fastened to the boom and jib with clips or nylon straps.
  - f. Check that all electric cables, shorting plugs, and terminating plugs are securely fastened (Figure 6-8).
2. Test the block-up limit controls for proper operation using either of the following methods:
  - a. **BOOM AND LUFFING JIB LOWERED:**  
Manually lift each weight—**one at a time**—while the engine is running. The load drum should not operate in up direction and the boom and luffing hoists should not operate in the down direction.

### CAUTION

#### Avoid Sheave Damage!

Use extreme care when testing block-up limit controls when boom and jib are raised.

If block-up limit control fails to stop load, immediately stop load by moving drum control handle to off or by applying drum working brake; otherwise, two-blocking may occur.

- b. **BOOM AND LUFFING JIB RAISED:**

**Slowly** hoist each load block and weight ball—**one at a time**—against the corresponding weight. When the chain goes slack, the corresponding load drum should stop hoisting and the boom and luffing hoists should not operate in down the direction.

## Block-Up Limit Adjustment

See Figure 6-9

Lower the boom and luffing jib onto blocking at ground level and adjust each limit switch as follows:

1. Adjust spring (10) tension so there is enough force to lift the weight of the chain and rotate actuating lever (6) up when the weight is lifted.
2. Loosen setscrew (11) in limit switch lever (4) so the lever is free to rotate.
3. Manually lift the weight to allow actuating lever (6) to rotate up.
4. Hold lever (6) at Dimension A.
5. Hold roller (5) on limit switch lever (4) against actuating lever (6) while performing step 6.
6. Turn limit switch shaft (3) **CLOCKWISE only enough to "click" limit switch open and hold**. Then securely tighten setscrew (11) in the limit switch lever.
7. Test the limit switch for proper operation (see Maintenance topic).
8. Repeat the adjustment steps until the limit switch operates properly.

*THIS PAGE INTENTIONALLY LEFT BLANK*

## ALPHABETICAL INDEX

Accessing Parts . . . . .	4-2
Assist Crane Requirements . . . . .	4-3
Automatic Boom Stop . . . . .	6-3
Blocked Crawlers . . . . .	4-2
Block-Up Limit . . . . .	6-13
Boom and Luffing Jib Angle Indicator . . . . .	6-1
Cable Cleanliness . . . . .	4-3
Change of Ownership Registration . . . . .	1-1
Connect Electric Cords and Adjust Electronic Devices . . . . .	4-20
Connecting/Disconnecting Electric Cables . . . . .	4-3
Counterweight Requirement . . . . .	4-2
Crane Data . . . . .	1-1
Crane Orientation . . . . .	1-1
Crane Orientation . . . . .	4-1
Crane Weights . . . . .	1-1
Crane Weights . . . . .	4-2
Crane/Attachment Identification . . . . .	1-1
English and Metric Conversions . . . . .	1-4
General Maintenance . . . . .	6-1
General Operation . . . . .	3-6
General Setup and Installation . . . . .	4-1
Handling Components . . . . .	4-2
Identification and Location of Components . . . . .	1-3
Identifying Jib Components . . . . .	4-2
Install Jib Load Line . . . . .	4-20
Installing Luffing Jib . . . . .	4-9
Introduction . . . . .	1-1
Jib Assembly Drawings . . . . .	4-2
Jib Stop . . . . .	6-9
Leaving Crane Unattended . . . . .	3-10
Load Line Reeving . . . . .	4-39
Lowering Boom and Jib . . . . .	4-27
Lube and Coolant Product Guide . . . . .	5-1
Lubrication . . . . .	5-1
Lubrication . . . . .	5-1
Luffing Jib Operating Controls . . . . .	3-6
Luffing Jib Raising Procedure . . . . .	4-2
Maintenance Procedures . . . . .	6-1
Manitowoc Dealer . . . . .	1-1
Operating Controls And Procedures . . . . .	3-1
Operating Controls . . . . .	4-2
Operating Precautions . . . . .	3-10
Pad Eye Usage for Wire Rope Reeving . . . . .	4-37
Physical Boom Stop . . . . .	6-7
Pin and Connecting Hole Cleanliness . . . . .	4-3
Preparing Crane for Luffing Jib . . . . .	4-7
Pre-Raising Checks . . . . .	4-21
Raising Boom and Jib . . . . .	4-23
Retaining Connecting Pins . . . . .	4-2
Safety Information . . . . .	2-1
Safety . . . . .	2-1
Setup And Installation . . . . .	4-1
Shipping Crane Components . . . . .	4-5
Shipping Data . . . . .	4-2
Standard Hand Signals for Controlling Crane Operations . . . . .	3-2

Wind Conditions ..... 3-10  
Wire Rope Installation ..... 4-30

Reference Only

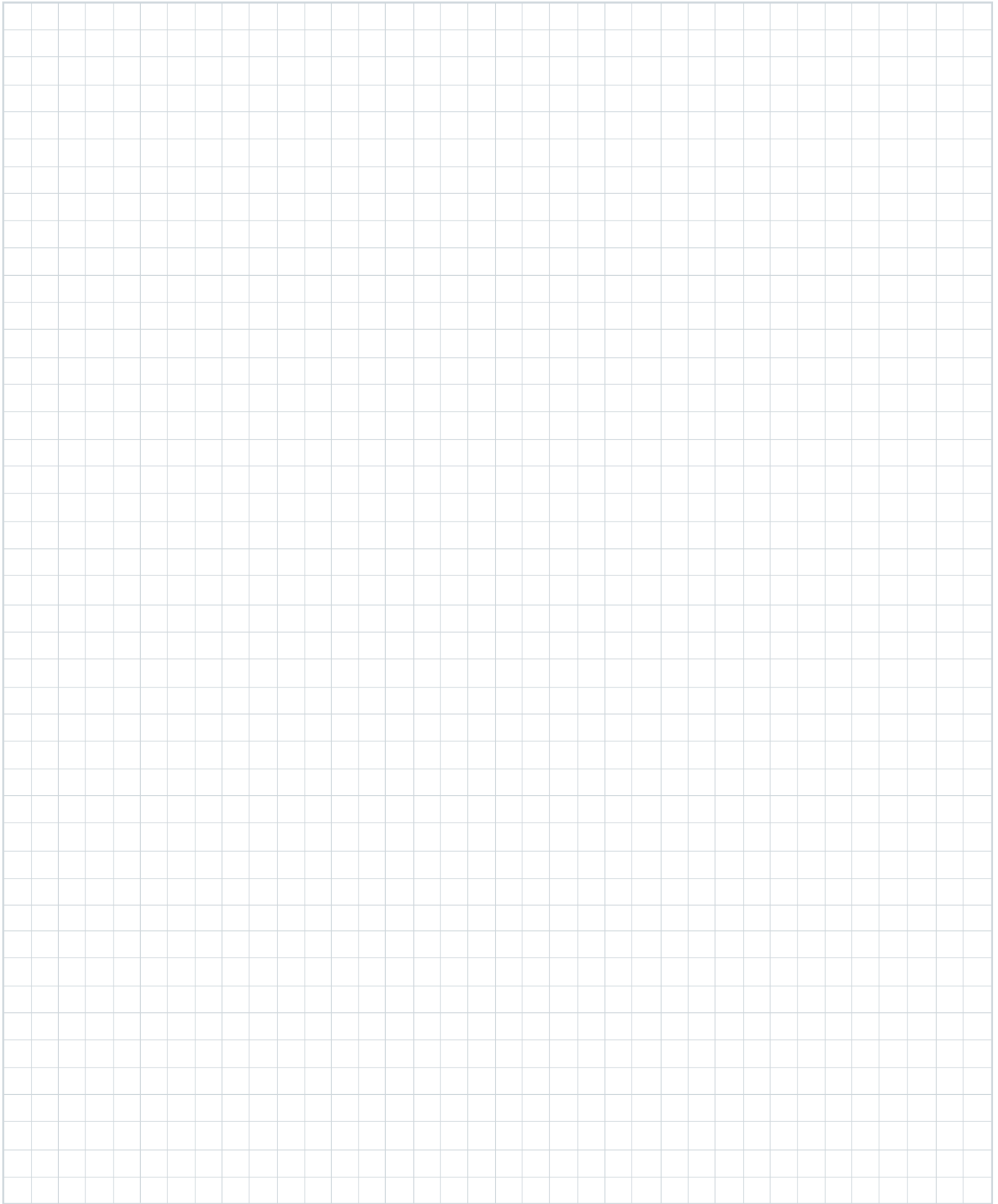

Grove

Manitowoc

National Crane

Potain

