

## MDT 249 J12

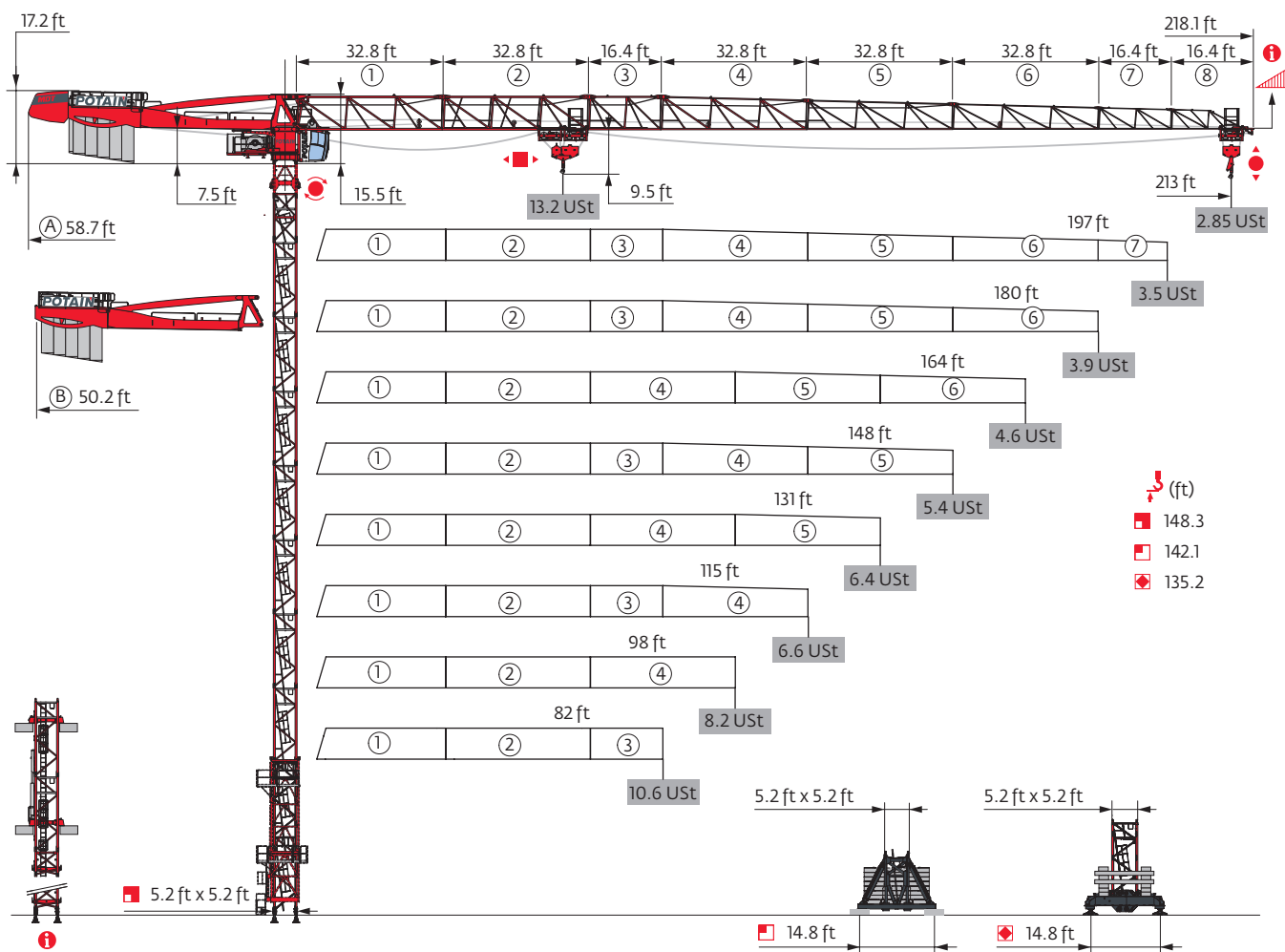

Potain Plus



Power Control

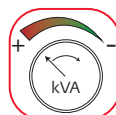

Top Site



Anti-collision systems

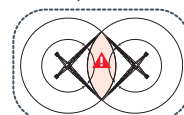

Mast - Reactions

5.2 ft City - P 42A									
Height (ft)	82	98	115	131	148	164	180	197	213
Height (ft)	147	147	147	141.7	147	147	147	136.2	136.2
Height + P <sub>+</sub> (ft)	147	147	147	141.7	147	147	147	136.2	136.2
Access Height (ft)	10.9 ft	0	0	0	1	0	0	0	2
	16.4 ft	7	7	7	6	7	7	5	5
	32.8 ft	1	1	1	1	1	1	1	1
F2 (Ust)	● 153	152	149	148	149	147	148	144	144
	■ 117	117	123	111	128	130	138	115	124
F3 (Ust)	● 119	117	112	111	103	101	101	97	97
	■ 83	82	87	73	89	91	97	75	83

5.2 ft City - S 41A									
Height (ft)	82	98	115	131	148	164	180	197	213
Height (ft)	141.1	141.1	141.1	141.1	141.1	141.1	135.5	130.2	135.5
Height + P <sub>+</sub> (ft)	141.1	141.1	141.1	141.1	141.1	141.1	135.5	130.2	135.5
Access Height (ft)	10.9 ft	0	0	0	0	0	1	2	1
	16.4 ft	8	8	8	8	8	7	6	7
		8	8	8	8	8	7	6	7
F1 (Ust)	● 88	86	88	88	87	87	89	87	89
	■ 71	71	73	72	74	74	74	71	77

5.2 ft City - ZD 463									
Height (ft)	82	98	115	131	148	164	180	197	213
Height (ft)	134.2	134.2	134.2	134.2	134.2	134.2	128.6	123.4	128.6
Height + P <sub>+</sub> (ft)	134.2	134.2	134.2	134.2	134.2	134.2	128.6	123.4	128.6
Access Height (ft)	10.9 ft	0	0	0	0	0	1	2	1
	16.4 ft	8	8	8	8	8	7	6	7
F1 (Ust)	● 85	83	84	84	84	83	85	83	86
	■ 67	67	68	68	68	69	69	65	72

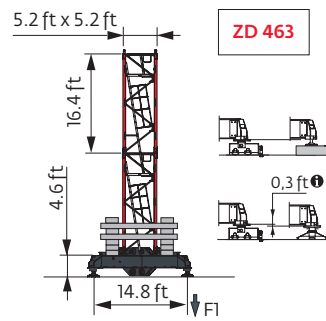
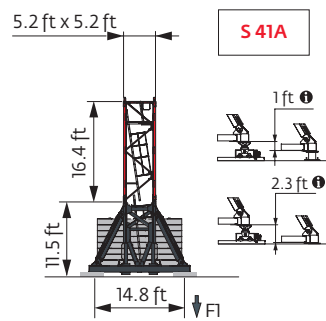
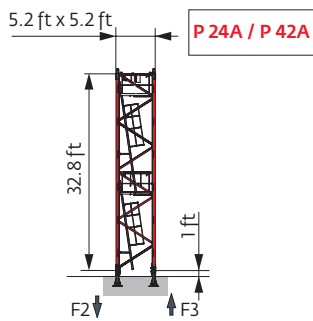

Note: When "ASCE" is noted in this data sheet it is referring to 115 mph Wind Zone, Exposure B, Design Wind Speed = 98 mph. See back cover for design wind speed calculations.

Motorized accesses: adapted mast compositions, base ballast and reactions.

Other mast compositions - Please consult us

**5.2 ft - P 42A**

Δ (ft)	82	98	115	131	148	164	180	197	213
(ft)	148.3	142.7	142.7	142.7	142.7	142.7	142.7	131.9	131.9
/ P <sub>r</sub> (ft)	148.3	142.7	142.7	142.7	142.7	142.7	142.7	131.9	131.9
	6.6 ft	1	1	1	1	1	1	1	1
	10.9 ft	1	2	2	2	2	2	1	1
	16.4 ft	6	5	5	5	5	5	5	5
	32.8 ft	1	1	1	1	1	1	1	1
F2 (Ust)	● 158	152	149	152	149	147	148	143	144
	■ 137	127	133	129	138	139	147	120	128
F3 (Ust)	● 123	117	112	114	103	102	101	97	97
	■ 102	91	96	91	98	100	107	80	88

**5.2 ft - S 41A**

Δ (ft)	82	98	115	131	148	164	180	197	213
(ft)	136.8	136.8	136.8	136.8	136.8	142.1	131.2	131.2	131.2
/ P <sub>r</sub> (ft)	136.8	136.8	136.8	136.8	136.8	142.1	131.2	131.2	131.2
	6.6 ft	1	1	1	1	1	1	1	1
	10.9 ft	2	2	2	2	1	0	0	0
	16.4 ft	6	6	6	6	6	7	7	7
F1 (Ust)	● 90	86	88	88	88	90	88	89	89
	■ 76	73	76	75	76	81	76	76	78

**5.2 ft - ZD 463**

Δ (ft)	82	98	115	131	148	164	180	197	213
(ft)	135.2	135.2	129.9	129.9	135.2	135.2	129.9	124.3	124.3
/ P <sub>r</sub> (ft)	135.2	135.2	129.9	129.9	135.2	135.2	129.9	124.3	124.3
	6.6 ft	1	1	1	1	1	1	1	1
	10.9 ft	1	1	2	2	1	1	2	0
	16.4 ft	7	7	6	6	7	7	6	7
F1 (Ust)	● 88	86	84	84	87	86	88	85	85
	■ 74	72	70	69	75	75	76	70	73

Anchorage



Base ballast

**⚙️ (USt) / 5.2 ft City - S 41A - 🚧**

▽\Δ\ (ft)	82	98	115	131	148	164	180	197	213
141.1	99.2	99.2	99.2	99.2	92.6	92.6			
135.5	99.2	92.6	92.6	92.6	86	86	92.6		92.6
130.2	92.6	92.6	92.6	86	79.4	79.4	86	92.6	86
113.8	79.4	72.8	72.8	72.8	66.1	66.1	72.8	72.8	72.8
97.4	66.1	66.1	59.5	66.1	59.5	52.9	52.9	59.5	66.1
81	66.1	59.5	52.9	59.5	52.9	52.9	46.3	52.9	66.1
64.6	66.1	59.5	52.9	59.5	52.9	52.9	46.3	52.9	59.5

**⚙️ (USt) / 5.2 ft City - ZD 463 - 🚧**

▽\Δ\ (ft)	82	98	115	131	148	164	180	197	213
134.2	93.7	88.2	88.2	88.2	82.7	82.7			
128.6	88.2	88.2	82.7	82.7	77.2	77.2	82.7		82.7
123.4	82.7	82.7	82.7	77.2	71.7	71.7	77.2	77.2	77.2
107	66.1	66.1	66.1	66.1	55.1	55.1	60.6	60.6	66.1
90.6	66.1	60.6	55.1	60.6	55.1	49.6	44.1	55.1	60.6
74.2	66.1	55.1	49.6	55.1	55.1	49.6	44.1	49.6	60.6
57.7	66.1	55.1	49.6	55.1	55.1	49.6	44.1	49.6	60.6

**⚙️ (USt) / 5.2 ft - S 41A - 🚧**

▽\Δ\ (ft)	82	98	115	131	148	164	180	197	213
142.1						99.2			
136.8	105.8	99.2	99.2	99.2	92.6	92.6			
131.2	99.2	92.6	92.6	92.6	86	86	92.6	92.6	92.6
114.8	79.4	79.4	79.4	79.4	72.8	72.8	72.8	79.4	72.8
98.4	66.1	66.1	66.1	66.1	59.5	59.5	59.5	59.5	66.1
82	66.1	59.5	52.9	59.5	52.9	52.9	46.3	59.5	66.1
65.6	66.1	59.5	52.9	52.9	52.9	52.9	46.3	52.9	66.1

**⚙️ (USt) / 5.2 ft - ZD 463 - 🚧**

▽\Δ\ (ft)	82	98	115	131	148	164	180	197	213
135.2	99.2	93.7			88.2	88.2			
129.9	93.7	88.2	88.2	88.2	82.7	82.7	88.2		
124.3	88.2	82.7	82.7	82.7	77.2	77.2	82.7	82.7	82.7
107.9	71.7	71.7	66.1	66.1	60.6	60.6	66.1	66.1	66.1
91.5	66.1	60.6	55.1	60.6	49.6	55.1	49.6	55.1	60.6
75.1	66.1	55.1	49.6	55.1	49.6	49.6	44.1	49.6	60.6
58.7	66.1	55.1	49.6	49.6	49.6	49.6	44.1	49.6	60.6

Load curves



(ft)		49	56	66	72	82	89	98	105	115	121	131	138	148	154	164	171	180	187	197	203	213	ft
<b>213</b>	10 → 53 94 - 102	13.2	12.4	10.2	9.1	7.8	7.1	6.6	6.4	5.7	5.4	4.9	4.6	4.3	4	3.7	3.6	3.3	3.2	3	2.85	2.7	USt
	10 → 54 97 - 105	13.2	12.7	10.6	9.4	8.1	7.4	6.6	6.6	6	5.6	5.1	4.9	4.5	4.3	4	3.8	3.5	3.4	3.2	3	2.85	USt <b>P+</b>
<b>197</b>	10 → 56 101 - 108	13.2	13.2	11.1	9.9	8.5	7.8	6.8	6.6	6.2	5.8	5.3	5	4.6	4.4	4.1	3.9	3.6	3.5	3.3			USt
	10 → 58 105 - 113	13.2	13.2	11.5	10.3	8.9	8.1	7.2	6.6	6.5	6.1	5.6	5.3	4.9	4.7	4.3	4.1	3.9	3.7	3.5			USt <b>P+</b>
<b>180</b>	10 → 56 101 - 109	13.2	13.2	11.1	9.9	8.5	7.8	6.9	6.6	6.2	5.8	5.3	5	4.6	4.4	4.1	3.9	3.6					USt
	10 → 58 106 - 115	13.2	13.2	11.6	10.4	9	8.2	7.2	6.7	6.6	6.2	5.6	5.3	4.9	4.7	4.4	4.2	3.9					USt <b>P+</b>
<b>164</b>	10 → 59 106 - 113	13.2	13.2	11.7	10.4	9	8.2	7.2	6.7	6.5	6.1	5.6	5.3	4.9	4.6	4.3							USt
	10 → 61 111 - 120	13.2	13.2	12.2	11	9.5	8.7	7.7	7.1	6.6	6.5	6	5.6	5.2	5	4.6							USt <b>P+</b>
<b>148</b>	10 → 61 109 - 118	13.2	13.2	12.1	10.8	9.3	8.5	7.5	6.9	6.6	6.4	5.8	5.5	5.1									USt
	10 → 64 116 - 125	13.2	13.2	12.8	11.4	9.9	9.1	8	7.4	6.7	6.6	6.2	5.9	5.4									USt <b>P+</b>
<b>131</b>	10 → 62 111 - 120	13.2	13.2	12.4	11.1	9.6	8.7	7.7	7.1	6.6	6.5	6											USt
	10 → 65 118 - 128	13.2	13.2	13.1	11.8	10.2	9.3	8.2	7.6	6.9	6.6	6.4											USt <b>P+</b>
<b>115</b>	10 → 60 107 - 115	13.2	13.2	11.8	10.6	9.1	8.3	7.3	6.8	6.6													USt
	10 → 63 114 - 115	13.2	13.2	12.6	11.3	9.7	8.9	7.9	7.3	6.6													USt <b>P+</b>
<b>98</b>	10 → 61	13.2	13.2	12.2	10.9	9.4	8.6	7.5															USt
	10 → 64	13.2	13.2	13	11.6	10.1	9.2	8.1															USt <b>P+</b>
<b>82</b>	10 → 63	13.2	13.2	12.6	11.3	9.7																	USt
	10 → 67	13.2	13.2	13.2	12.2	10.5																	USt <b>P+</b>

$\text{USt} = \text{USt} - 0.63 \text{ USt max.}$



(ft)		49	56	66	72	82	89	98	105	115	121	131	138	148	154	164	171	180	187	197	203	213	ft	
<b>213</b>	8 → 53 95 - 97	13.2	12.5	10.3	9.2	7.9	7.2	6.5	6	5.4	5	4.5	4.3	3.9	3.7	3.4	3.2	2.95	2.8	2.6	2.5	2.3	USt	
	8 → 54 98 - 100	13.2	12.8	10.6	9.5	8.2	7.5	6.6	6.3	5.6	5.3	4.8	4.5	4.1	3.9	3.6	3.4	3.2	3	2.8	2.7	2.5	USt <b>P+</b>	
<b>197</b>	8 → 57 102 - 104	13.2	13.2	11.1	10	8.6	7.8	6.9	6.5	5.9	5.5	5	4.7	4.3	4.1	3.7	3.5	3.3	3.1	2.9			USt	
	8 → 58 106 - 108	13.2	13.2	11.6	10.4	9	8.2	7.2	6.7	6.2	5.8	5.3	5	4.6	4.3	4	3.8	3.5	3.4	3.2			USt <b>P+</b>	
<b>180</b>	8 → 57 102 - 104	13.2	13.2	11.2	10	8.6	7.9	6.9	6.6	5.9	5.5	5	4.7	4.3	4.1	3.8	3.6	3.3					USt	
	8 → 59 107 - 109	13.2	13.2	11.7	10.5	9	8.3	7.3	6.8	6.2	5.8	5.3	5	4.6	4.4	4	3.8	3.6					USt <b>P+</b>	
<b>164</b>	8 → 59 106 - 109	13.2	13.2	11.7	10.5	9	8.3	7.3	6.7	6.2	5.8	5.3	5	4.5	4.3	4							USt	
	8 → 61 112 - 115	13.2	13.2	12.3	11	9.5	8.7	7.7	7.2	6.6	6.2	5.6	5.3	4.9	4.6	4.3							USt <b>P+</b>	
<b>148</b>	8 → 61 110 - 112	13.2	13.2	12.2	10.9	9.4	8.6	7.6	7	6.4	6	5.5	5.2	4.7									USt	
	8 → 64 117 - 119	13.2	13.2	12.8	11.5	10	9.1	8.1	7.5	6.7	6.5	5.9	5.6	5.1									USt <b>P+</b>	
<b>131</b>	8 → 62 112 - 115	13.2	13.2	12.5	11.2	9.6	8.8	7.8	7.2	6.6	6.2	5.6											USt	
	8 → 65 119 - 122	13.2	13.2	13.2	11.8	10.2	9.4	8.3	7.7	6.9	6.6	6.1											USt <b>P+</b>	
<b>115</b>	8 → 60 108 - 110	13.2	13.2	11.9	10.6	9.2	8.4	7.4	6.8	6.3													USt	
	8 → 63	13.2	13.2	12.6	11.3	9.8	9	7.9	7.4	6.6													USt <b>P+</b>	
<b>98</b>	8 → 61	13.2	13.2	12.2	11	9.4	8.6	7.6															USt	
	8 → 65	13.2	13.2	13	11.7	10.1	9.3	8.2																USt <b>P+</b>
<b>82</b>	8 → 63	13.2	13.2	12.7	11.4	9.8																	USt	
	8 → 67	13.2	13.2	13.2	12.2	10.6																	USt <b>P+</b>	

$\text{USt} = \text{USt} - 0.18 \text{ USt max.}$

Jib weight & counter-jib ballast

(lb) (+/- 5%)									
	10,141 lb	3,373 lb	(lb)	6,768 lb	3,373 lb	(lb)			
<b>213 ft</b>	27,761	26,985	27,961	5	1	54,079	7	2	54,123
<b>197 ft</b>	27,090	26,381	27,247	5	1	54,079	7	2	54,123
<b>180 ft</b>	26,420	25,710	26,577	5	0	50,706	7	1	50,750
<b>164 ft</b>	24,562	23,852	24,718	4	2	47,311	6	2	47,355
<b>148 ft</b>	24,877	24,167	25,033	4	2	47,311	6	2	47,355
<b>131 ft</b>	23,089	22,379	23,246	4	1	43,938	6	1	43,982
<b>115 ft</b>	22,824	22,115	22,981	4	0	40,565	5	2	40,587
<b>98 ft</b>	20,723	20,014	20,880	3	2	37,170	5	1	37,214
<b>82 ft</b>	19,557	18,847	19,714	3	1	33,797	4	2	33,819

CBS - 10,141 lb

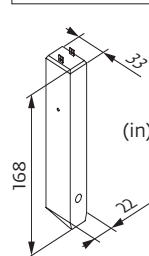

CBU - 6,768 lb

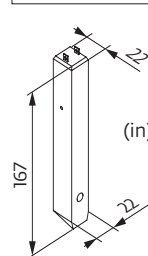

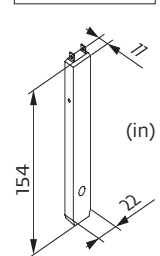

CBY - 3,373 lb





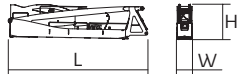
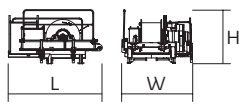
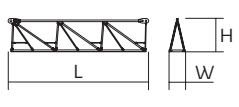
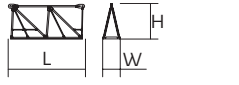
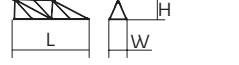

Dimensions and weight

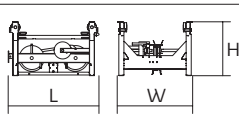
Slewing crane part:  213 ft -  50 LVF

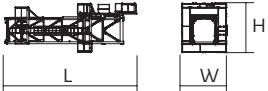
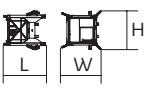
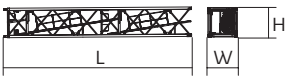
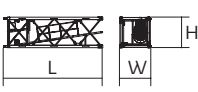

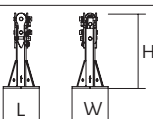
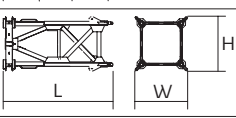
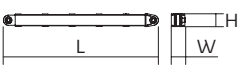
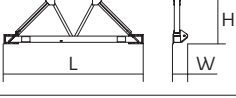
Slewing crane part		L (ft)	W (ft)	H (ft)	lb (+/- 5%)
Counter-jib		36.1	3.8	8.1	19,213
		36.1	3.8	8.1	18,629
Towerhead + cab		15.6	7.5	8.4	17,372
Hoisting winch (+ rope)		10.6	8.1	6.2	6,945
		10.6	10.8	5.8	9,235
Jib section		35.5	5.6	9	7,959
Jib section		33.8	3.9	7.9	5,335
		33.5	3.9	7.8	3,439
		33.6	3.9	6.9	2,723
		33.4	3.9	6	1,753
Jib section		17.3	3.9	7.8	2,116
		16.7	3.9	5	683
Jib section		16.7	3.9	4.6	485
Trolley		6.1	5	3.4	882
Pulley block		3.9	1.4	7.6	1,003
Trolley		5.2	5	3.2	463
Trolley		5.6	5	3	540
		6.1	5	3.2	520
Pulley block		5.4	0.7	5.8	992
		3.6	0.9	5.3	584

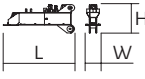
Crane tower	L (ft)	W (ft)	H (ft)	lb (+/- 5%)
Telescopic cage T 41 	5.2 ft	35.6	12.3	13.5 15,653
K40/K40-2 	5.2 ft	7.3	6.9	6.8 2,932
K 447E KM 447E KM 449E 	5.2 ft	33.5 33.5 33.5	5.3 5.3 5.3	5.3 5.3 5.3 7,474 7,088 8,830
K 447A KMT 447A K 449A KMT 449A 	5.2 ft	17.1 17.1 17.1 17.1	5.5 5.5 5.5 5.5	5.3 5.3 5.3 5.3 4,079 3,847 4,916 4,696
K 447C KMT 447C 	5.2 ft	11.3 11.6	5.5 5.5	5.3 5.3 2,998 2,976
Fixing angles 	P 24A / P 42A	1.8	1.8	3.8 529
Basic mast unit 	S 41A	11.9	6.4	6.8 7,132
Struts 	S 41A	10.4	0.9	0.8 816
Half-bearer 	S 41A	16.7	2	5.8 2,315
Cross girder 	ZD 463	25.1	3.8	4.5 7,904
1/2 Cross girder 	ZD 463	11.2	2.3	4.4 3,649

Mechanisms

480 V - 60 Hz											hp	kW			
	50 LVF 30 Optima	fpm	105	135	185	267	54	71	97	135	50	37	1,106 ft		
		USt	6.6	5	3.3	1.1	13.2	9.9	6.6	2.5					
	90 HPL™ 30	fpm	176	228	326	469	723	90	120	172	244	361	90	66	2,434 ft
		USt	6.6	5	3.3	1.7	0.2	13.2	9.9	6.6	3.3	0.9			
	6 DVF 4 Optima	fpm	0 → 164 (13.2 USt) 0 → 328 (6.6 USt) 0 → 394 (3.3 USt)								5.5	4			
	RVF 162 Optima+	rpm					0 → 0.9				2 x 7.5	2 x 5.5			

480 V (+6% -10%) 60 Hz	50 LVF: 58 → 38 kVA	
	90 HPL™: 90 → 54 kVA	

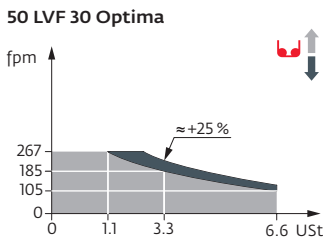

These mast combinations meet the EN 14439 and ASME B30.3-2016 specifications for “out of service” wind conditions, provided the illustrated wind speed matches the required design wind speed for the location of the tower crane. The “out of service” design wind speed was determined in accordance with ASCE 7-10, Figure 26.5-1A. The wind velocity, used for this configuration was 98 mph (158 kph), which represents a nominal design 3-second wind gust at 33 ft (10 m) above ground for Exposure B category. A factor of 0.85 was applied to the 700-year ultimate design wind speed of 115 mph (185 kph), per ASCE 37-02, with the assumption that this crane is considered a temporary structure used during a construction period of 2 years or less.

- Jib elevation
- Standard equipment
- Options
- Potain Plus function: Plus load curves
- Hook heights with Plus load curves
- Reactions in service
- Reactions out of service
- Total ballast weight
- Jib weight
- Lorry 44 ft
- Container High Cube 40 ft, and/or Flat Rack 20 ft
- Hoisting
- Trolleying
- Slewing
- Travelling
- Required power
- Power Control Function: wind speeds adapted to the available power
- Consult us

This commercial document is not legally binding. For any technical information, please refer to the corresponding instructions.

