

MDLT 1109

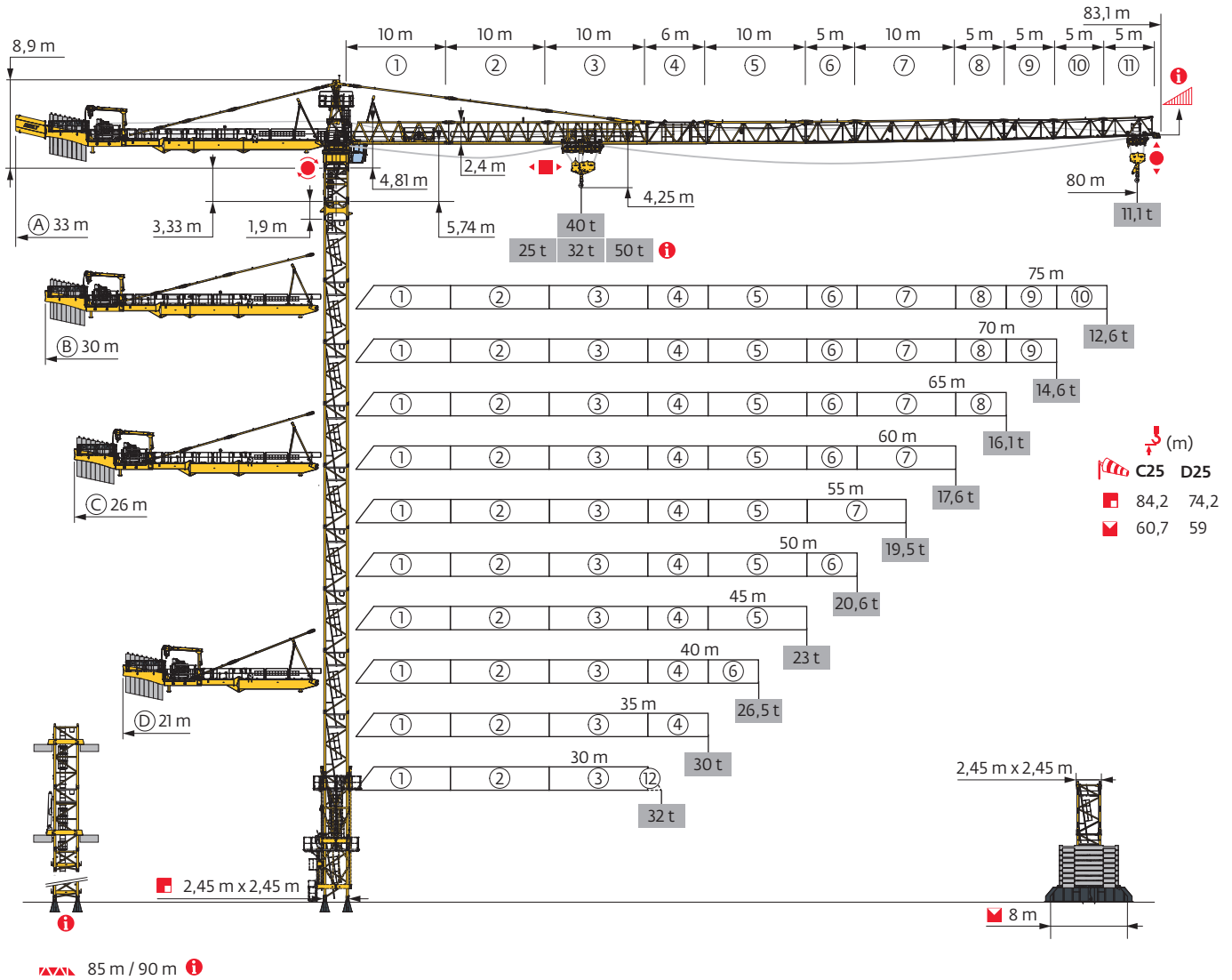

85 m / 90 m

Potain Plus



Power Control

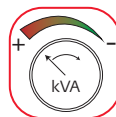

Top Site

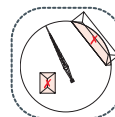

Top Tracing 3

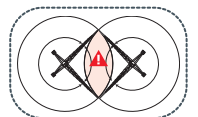

Mât - Réactions / Mast - Reaktionskräfte / Mast - Reactions / Mástil - Reacciones / Torre - Reazioni
 Tramo - Reações / Реакция опор мачты

| 2,45 m - P 854A - C25 | | | | | | | | | | | |
|---|--------|-----|-----|-----|-----|-----|-----|-----|-----|-----|-----|
| AVAN (m) | 30 | 35 | 40 | 45 | 50 | 55 | 60 | 65 | 70 | 75 | 80 |
| ↕ (m) | 64 | 64 | 64 | 64 | 64 | 64 | 64 | 64 | 64 | 64 | 64 |
| ↕/P* (m) | i | | | | | | | | | | |
|  | 3,33 m | 1 | 1 | 1 | 1 | 1 | 1 | 1 | 1 | 1 | 1 |
| | 1,9 m | 1 | 1 | 1 | 1 | 1 | 1 | 1 | 1 | 1 | 1 |
| | 5 m | 12 | 12 | 12 | 12 | 12 | 12 | 12 | 12 | 12 | 12 |
| F2 (t) | ● | 349 | 373 | 375 | 370 | 376 | 374 | 374 | 388 | 367 | 366 |
| | ■ | 366 | 357 | 350 | 362 | 361 | 367 | 370 | 382 | 374 | 396 |
| F3 (t) | ● | 230 | 247 | 245 | 242 | 265 | 261 | 258 | 270 | 248 | 245 |
| | ■ | 267 | 250 | 240 | 254 | 250 | 255 | 254 | 267 | 256 | 278 |
| ↕ (m) D25 | 64 | 64 | 64 | 64 | 64 | 64 | 64 | 64 | 64 | 64 | 64 |
| ↕/P* (m) D25 | i | | | | | | | | | | |

| 2,45 m - P 880A - C25 | | | | | | | | | | | |
|---|--------|------|------|------|------|------|------|------|------|------|------|
| AVAN (m) | 30 | 35 | 40 | 45 | 50 | 55 | 60 | 65 | 70 | 75 | 80 |
| ↕ (m) | 84,2 | 79,2 | 79,2 | 79,2 | 79,2 | 82,6 | 82,6 | 80,9 | 79,2 | 77,6 | 75,9 |
| ↕/P* (m) | i | | | | | | | | | | |
|  | 3,33 m | 1 | 1 | 1 | 1 | 1 | 1 | 1 | 1 | 1 | 1 |
| | 1,9 m | 1 | 1 | 1 | 1 | 1 | 1 | 1 | 1 | 1 | 1 |
| | 3,33 m | 0 | 0 | 0 | 0 | 0 | 1 | 1 | 2 | 0 | 1 |
| | 5 m | 16 | 15 | 15 | 15 | 15 | 15 | 15 | 14 | 15 | 14 |
| F2 (t) | ● | 440 | 448 | 452 | 444 | 446 | 457 | 455 | 451 | 453 | 423 |
| | ■ | 730 | 643 | 642 | 647 | 646 | 723 | 721 | 711 | 649 | 635 |
| F3 (t) | ● | 291 | 296 | 294 | 291 | 289 | 313 | 310 | 287 | 313 | 288 |
| | ■ | 601 | 510 | 504 | 513 | 509 | 580 | 575 | 568 | 509 | 480 |
| ↕ (m) D25 | 74,2 | 74,2 | 74,2 | 74,2 | 74,2 | 74,2 | 74,2 | 72,6 | 72,6 | 72,6 | 70,9 |
| ↕/P* (m) D25 | i | | | | | | | | | | |

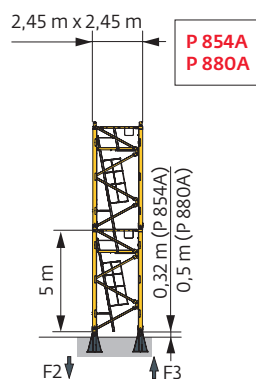

i Accès motorisés : compositions de mât, de lest de base et réactions adaptées. / Motorisierter Zugang vom : Mastzusammensetzung, Grundballast und Reaktionskräfte sind angepasst. / Motorized accesses: adapted mast composition, base ballast and reactions. / Acceso a cabina con elevador: Adaptación de composición de mástil, lastre de base y reacciones. / Accessi motorizzati: composizioni elementi torre, zavorre di base e reazioni aggiornate. / Acessos motorizados: composições de coluna, lastro da base e reações adaptadas. / Лифты : адаптированная композиция мачты, базовый балласт и нагрузки.

Pour toute demande spécifique merci de nous consulter. / Für jede spezielle Anfrage, bitte bei uns rückfragen.
 For any special request, please consult us. / Para toda pregunta específica, gracias por consultarnos.
 Per qualsiasi domanda specifica, vi preghiamo di contattarci. / Queiram por favor contactar-nos para qualquer esclarecimento técnico adicional.
 В случае нестандартных вопросов, пожалуйста, консультируйтесь с нами.

2,45 m - ZY 854 - C25

| ΔΔΔΔ (m) | 30 | 35 | 40 | 45 | 50 | 55 | 60 | 65 | 70 | 75 | 80 |
|--------------------------|--------|------|-----|------|-----|------|-----|-----|------|------|------|
| h (m) | 60,7 | 42,3 | 39 | 40,7 | 39 | 42,3 | 44 | 39 | 37,3 | 52,3 | 55,7 |
| h/P ₊ (m) | | | | | | | | | | | |
| | 3,33 m | 1 | 1 | 1 | 1 | 1 | 1 | 1 | 1 | 1 | 1 |
| | 1,9 m | 1 | 1 | 1 | 1 | 1 | 1 | 1 | 1 | 1 | 1 |
| | 3,33 m | 0 | 2 | 1 | 0 | 1 | 2 | 1 | 1 | 2 | 0 |
| | 5 m | 11 | 6 | 6 | 7 | 6 | 6 | 7 | 6 | 5 | 8 |
| Fl (t) | ● 197 | 176 | 174 | 173 | 173 | 176 | 182 | 182 | 186 | 207 | 212 |
| | ■ 164 | 146 | 151 | 148 | 152 | 154 | 159 | 162 | 169 | 178 | 183 |
| h (m) D25 | 59 | 42,3 | 39 | 40,7 | 39 | 42,3 | 44 | 39 | 37,3 | 52,3 | 55,7 |
| h/P ₊ (m) D25 | | | | | | | | | | | |

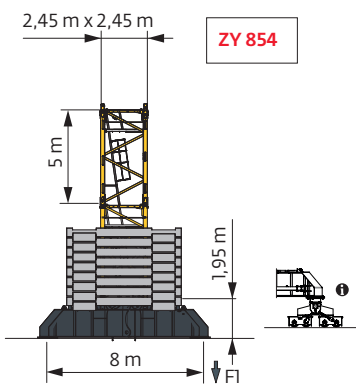

Ancrages / Verankerungen / Anchorages / Anclajes / Ancoraggi
 Ancoragem / нкрепа

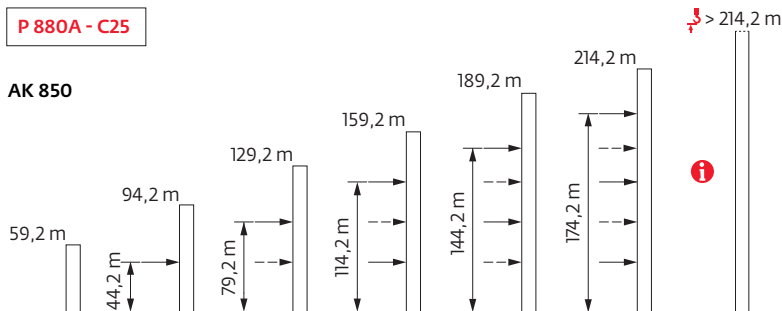
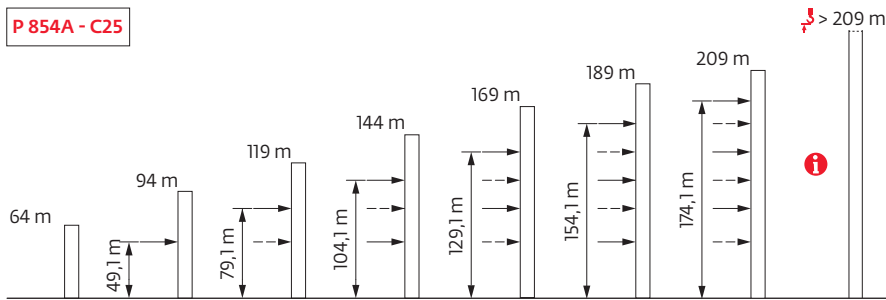

Lest de base / Grundballast / Base ballast / Lastre de base / Zavorra di base
 Lastro da base / Базовый Балласт

| ▲≡(t) / ▣ 2,45 m - ZY 854 - ▣ - C25 | | | | | | | | | | | |
|-------------------------------------|-----|-----|-----|-----|-----|-----|-----|-----|-----|-----|-----|
| ▲▼▲ (m) | 30 | 35 | 40 | 45 | 50 | 55 | 60 | 65 | 70 | 75 | 80 |
| 60,7 | 156 | | | | | | | | | | |
| 55,7 | 144 | | | | | | | | | | 216 |
| 52,3 | 132 | | | | | | | | | 204 | 216 |
| 44 | 108 | | | | | | 144 | | | 192 | 204 |
| 42,3 | 108 | 132 | | | | 132 | 132 | | | 192 | 204 |
| 40,7 | 108 | 132 | | 132 | | 132 | 132 | | | 192 | 204 |
| 39 | 108 | 132 | 132 | 132 | 132 | 132 | 132 | 168 | | 192 | 192 |
| 37,3 | 108 | 132 | 132 | 132 | 132 | 132 | 132 | 168 | 180 | 192 | 192 |
| 32,3 | 108 | 132 | 132 | 132 | 132 | 132 | 132 | 168 | 180 | 180 | 192 |
| 27,3 | 108 | 132 | 132 | 132 | 132 | 132 | 132 | 156 | 180 | 180 | 180 |
| 22,3 | 108 | 132 | 132 | 132 | 132 | 132 | 132 | 156 | 180 | 180 | 180 |
| 17,3 | 108 | 132 | 132 | 132 | 132 | 132 | 132 | 156 | 180 | 180 | 180 |

Courbes de charges / Lastkurven / Load curves / Curvas de cargas / Curve di carico
 Curvas de carga / Кривые нагрузок



| | | (m) | | | | | | | | | | | | | | | | | | | | | |
|----|------------|-------------------------------------|----|----|----|----|---|----|----|----|----|----|----|----|----|----|----|----|----|----|----|---|--|
| | | 22 | 25 | 30 | 35 | 40 | 45 | 47 | 50 | 52 | 55 | 57 | 60 | 62 | 65 | 67 | 70 | 72 | 75 | 77 | 80 | m | |
| 80 | 4,7 → 23,3 | 40 36,9 30,1 25,2 21,5 | | | | | 20 19,5 18,2 17,4 16,3 15,7 14,8 14,2 13,5 13 12,3 11,9 11,4 11 10,5 t | | | | | | | | | | | | | | | | |
| | 4,7 → 23,3 | 40 37 30,2 25,4 21,8 | | | | | 20 19,7 18,5 17,7 16,7 16,1 15,2 14,7 13,9 13,5 12,9 12,5 11,9 11,6 11,1 t P+ | | | | | | | | | | | | | | | | |
| 75 | 4,7 → 24,3 | 40 38,7 31,6 26,5 22,7 | | | | | 20 20 19,1 18,3 17,2 16,5 15,6 15 14,2 13,7 13 12,6 12 t | | | | | | | | | | | | | | | | |
| | 4,7 → 24,3 | 40 38,7 31,7 26,7 23 20,1 | | | | | 20 19,4 18,6 17,5 16,9 16 15,4 14,7 14,2 13,6 13,2 12,6 t P+ | | | | | | | | | | | | | | | | |
| 70 | 4,7 → 25,8 | 40 40 33,8 28,4 24,4 21,3 20,2 | | | | | 20 19,6 18,4 17,7 16,7 16,1 15,2 14,7 14 t | | | | | | | | | | | | | | | | |
| | 4,7 → 25,8 | 40 40 34 28,7 24,8 21,7 20,7 | | | | | 20 20 18,9 18,2 17,2 16,6 15,8 15,3 14,6 t P+ | | | | | | | | | | | | | | | | |
| 65 | 4,7 → 26,2 | 40 40 34,4 28,9 24,8 21,6 20,6 | | | | | 20 19,9 18,7 18 17 16,4 15,5 t | | | | | | | | | | | | | | | | |
| | 4,7 → 26,2 | 40 40 34,6 29,2 25,3 22,1 21,1 | | | | | 20 20 19,1 18,4 17,5 16,9 16,1 t P+ | | | | | | | | | | | | | | | | |
| 60 | 4,7 → 26,2 | 40 40 34,4 29 24,9 21,7 20,6 | | | | | 20 19,9 18,7 18 17 t | | | | | | | | | | | | | | | | |
| | 4,7 → 26,2 | 40 40 34,5 29,2 25,2 22,1 21 | | | | | 20 20 19,1 18,4 17,6 t P+ | | | | | | | | | | | | | | | | |
| 55 | 4,7 → 26,5 | 40 40 34,9 29,4 25,2 22 20,9 | | | | | 20 20 19 t | | | | | | | | | | | | | | | | |
| | 4,7 → 26,5 | 40 40 35 29,5 25,4 22,2 21,1 | | | | | 20 20 19,5 t P+ | | | | | | | | | | | | | | | | |
| 50 | 4,7 → 27,3 | 40 40 36 30,4 26,1 22,8 21,6 20,1 | | | | | t | | | | | | | | | | | | | | | | |
| | 4,7 → 27,3 | 40 40 36,2 30,7 26,5 23,2 22,1 20,6 | | | | | t P+ | | | | | | | | | | | | | | | | |
| 45 | 4,7 → 27 | 40 40 35,7 30 25,8 22,5 | | | | | t | | | | | | | | | | | | | | | | |
| | 4,7 → 27,1 | 40 40 35,9 30,4 26,3 23 | | | | | t P+ | | | | | | | | | | | | | | | | |
| 40 | 4,7 → 27,7 | 40 40 36,6 30,8 26,5 | | | | | t | | | | | | | | | | | | | | | | |
| | 4,7 → 27,7 | 40 40 36,6 30,8 26,5 | | | | | t P+ | | | | | | | | | | | | | | | | |
| 35 | 4,7 → 27 | 40 40 35,6 30 | | | | | t | | | | | | | | | | | | | | | | |
| | 4,7 → 27 | 40 40 35,6 30 | | | | | t P+ | | | | | | | | | | | | | | | | |
| 30 | 4,7 → 24,5 | 40 39,2 32 | | | | | t | | | | | | | | | | | | | | | | |
| | 4,7 → 24,5 | 40 39,2 32 | | | | | t P+ | | | | | | | | | | | | | | | | |

$W_{40} = W_{20} - 1,91 \text{ t max.}$



| | | (m) | | | | | | | | | | | | | | | | | | | | | |
|----|------------|-------------------------------------|----|----|----|----|--|----|----|----|----|----|----|----|----|----|----|----|----|----|----|---|--|
| | | 22 | 25 | 30 | 35 | 40 | 45 | 47 | 50 | 52 | 55 | 57 | 60 | 62 | 65 | 67 | 70 | 72 | 75 | 77 | 80 | m | |
| 80 | 3,8 → 23,3 | 40 36,9 30 25,1 21,4 | | | | | 19 18,1 16,7 16 14,9 14,2 13,3 12,7 12 11,5 10,8 10,4 9,9 9,5 9 t | | | | | | | | | | | | | | | | |
| | 3,8 → 23,3 | 40 37 30,3 25,4 21,7 | | | | | 19,3 18,4 17,1 16,4 15,3 14,7 13,8 13,3 12,6 12,1 11,5 11,1 10,5 10,2 9,7 t P+ | | | | | | | | | | | | | | | | |
| 75 | 3,8 → 24,1 | 40 38,4 31,3 26,2 22,4 | | | | | 20 19 17,6 16,8 15,7 15 14,1 13,5 12,7 12,2 11,5 11,1 10,5 t | | | | | | | | | | | | | | | | |
| | 3,8 → 24,1 | 40 38,5 31,4 26,4 22,6 | | | | | 20 19,2 17,9 17,1 16 15,4 14,5 14 13,2 12,7 12,1 11,7 11,1 t P+ | | | | | | | | | | | | | | | | |
| 70 | 3,8 → 25,5 | 40 40 33,4 28 24 20,8 | | | | | 20 18,8 18 16,8 16,1 15,1 14,5 13,6 13,1 12,4 t | | | | | | | | | | | | | | | | |
| | 3,8 → 25,5 | 40 40 33,5 28,1 24,1 21 20,3 | | | | | 19,1 18,3 17,2 16,5 15,5 15 14,2 13,7 13 t P+ | | | | | | | | | | | | | | | | |
| 65 | 3,8 → 26 | 40 40 34,1 28,7 24,6 21,4 20,3 | | | | | 19,4 18,5 17,3 16,6 15,6 15 14,1 t | | | | | | | | | | | | | | | | |
| | 3,8 → 26 | 40 40 34,2 28,8 24,8 21,6 20,6 | | | | | 19,6 18,8 17,7 17 16,1 15,5 14,7 t P+ | | | | | | | | | | | | | | | | |
| 60 | 3,8 → 26,1 | 40 40 34,2 28,7 24,6 21,5 20,4 | | | | | 19,4 18,5 17,3 16,6 15,6 t | | | | | | | | | | | | | | | | |
| | 3,8 → 26,1 | 40 40 34,3 28,9 24,9 21,7 20,6 | | | | | 19,7 18,9 17,8 17,1 16,2 t P+ | | | | | | | | | | | | | | | | |
| 55 | 3,8 → 26,5 | 40 40 34,9 29,4 25,2 22 20,9 | | | | | 19,9 19 17,8 t | | | | | | | | | | | | | | | | |
| | 3,8 → 26,6 | 40 40 35 29,5 25,4 22,2 21,2 | | | | | 20 19,3 18,3 t P+ | | | | | | | | | | | | | | | | |
| 50 | 3,8 → 27,3 | 40 40 36 30,4 26,1 22,8 21,6 20,1 | | | | | t | | | | | | | | | | | | | | | | |
| | 3,8 → 27,3 | 40 40 36,2 30,7 26,5 23,2 22,1 20,6 | | | | | t P+ | | | | | | | | | | | | | | | | |
| 45 | 3,8 → 27 | 40 40 35,7 30 25,8 22,5 | | | | | t | | | | | | | | | | | | | | | | |
| | 3,8 → 27,1 | 40 40 35,9 30,4 26,3 23 | | | | | t P+ | | | | | | | | | | | | | | | | |
| 40 | 3,8 → 27,7 | 40 40 36,6 30,8 26,5 | | | | | t | | | | | | | | | | | | | | | | |
| | 3,8 → 27,7 | 40 40 36,6 30,8 26,5 | | | | | t P+ | | | | | | | | | | | | | | | | |
| 35 | 3,8 → 27 | 40 40 35,6 30 | | | | | t | | | | | | | | | | | | | | | | |
| | 3,8 → 27 | 40 40 35,6 30 | | | | | t P+ | | | | | | | | | | | | | | | | |
| 30 | 3,8 → 24,5 | 40 39,2 32 | | | | | t | | | | | | | | | | | | | | | | |
| | 3,8 → 24,5 | 40 39,2 32 | | | | | t P+ | | | | | | | | | | | | | | | | |

$W_{40} = W_{20} - 1,15 \text{ t max.}$

Lest de contre-flèche / Gegenauslegerballast / Counter-jib ballast / Lastre de contra-flecha / Zavorra di controbraccio
 Lastro da contra lança / Противовес стрелы

| Span (m) | 150 HPL™ | | | 270 LVF GH | | |
|----------|----------|---------|-------------|------------|---------|-------------|
| | 6600 kg | 4700 kg | Weight (kg) | 6600 kg | 4700 kg | Weight (kg) |
| 80 m | 7 | 1 | 50900 | 6 | 2 | 49000 |
| 75 m | 6 | 2 | 49000 | 5 | 3 | 47100 |
| 70 m | 6 | 2 | 49000 | 6 | 1 | 44300 |
| 65 m | 7 | 0 | 46200 | 5 | 2 | 42400 |
| 60 m | 8 | 0 | 52800 | 6 | 2 | 49000 |
| 55 m | 5 | 3 | 47100 | 6 | 1 | 44300 |
| 50 m | 7 | 0 | 46200 | 5 | 2 | 42400 |
| 45 m | 4 | 3 | 40500 | 5 | 1 | 37700 |
| 40 m | 8 | 0 | 52800 | 7 | 1 | 50900 |
| 35 m | 5 | 3 | 47100 | 7 | 0 | 46200 |
| 30 m | 6 | 0 | 39600 | 5 | 1 | 37700 |

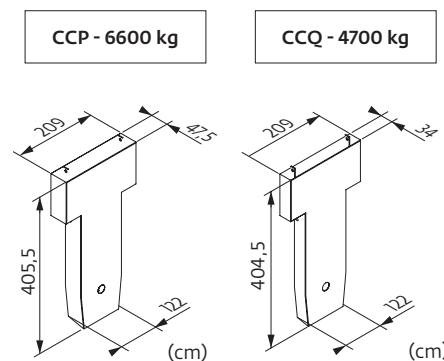









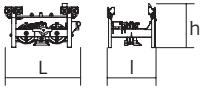

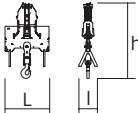

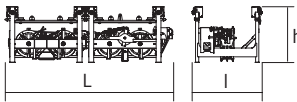

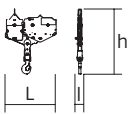

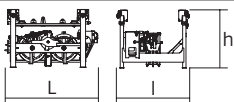

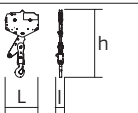

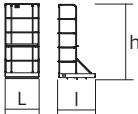
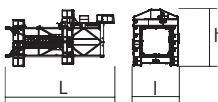
Encombrenment et poids / Abmessungen und Gewicht / Dimensions and weight / Dimensiones y peso / Ingombro e peso dimensões e pesos / габаритные размеры и вес

Partie tournante / Drehender Kranteil / Slewing crane part / Parte giratoria
 Parte rotante / Parte rotativa / Поворотная часть : 80 m - 150 HPL™

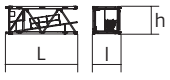

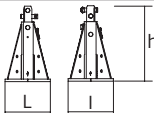
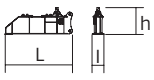
| Partie tournante / Drehender Kranteil / Slewing crane part Parte giratoria / Parte rotante / Parte rotativa / Поворотная часть | L (m) | l (m) | h (m) | kg (+/- 5%) | | |
|---|--|-------------|-------|----------------|------|-------|
| Contre-flèche / Gegenausleger Counter-jib / Contra-flecha Controbraccio / Contra-lança Контр-стрела | | 7,86 | 2,21 | 2,8 | 9600 | |
| | | 8,36 | 2,02 | 2,44 | 7300 | |
| | | 5,35 | 1,62 | 2,74 | 4580 | |
| | | 3,35 | 1,64 | 2,42 | 3080 | |
| | (A) 31,15 6,68 6,19 32200 (B) 28,42 6,68 6,19 31800 (C) 25,42 6,68 6,14 27600 (D) 20,42 6,68 6,15 22000 | | | | | |
| Porte-flèche / Auslegerträger Cathead / Porta-flecha Cuspide / Suporte de lança Оголовок | | 6,3 | 1,88 | 2,22 | 8100 | |
| Cabine / Kabine Cab / Cabina Cabina / Cabina Кабина | | Ultra View | 3,36 | 2,28 | 2,49 | 3000 |
| | | 12,45 m | 3 | 2,9 | 3 | 16800 |
| | | 7,17 | 3 | 3 | 3 | 19800 |
| Treuil de levage (+ câble) / Hubwerk (+ Seil) Hoisting winch (+ rope) Mecanismo de elevación (+ cabo) Argano di sollevamento (+ fune) Guincho de elevação (+ cabo) Подъемная лебедка (+ канатом) | | 150 HPL™ | 4,94 | 2,02 | 2 | 9280 |
| | | 270 LVF GH | 5,62 | 2,18 | 2,37 | 14130 |
| Élément de flèche / Auslegerement Jib section / Elemento de flecha Elemento di braccio / Elemento de lança Секция стрелы | | ① 15 DVF | 10,43 | 2,26 | 2,7 | 10055 |
| | | ② | 10,38 | 1,38 | 2,77 | 6900 |
| | | ③ | 10,36 | 1,38 | 2,41 | 7400 |
| | | ⑤ | 10,49 | 1,38 | 2,37 | 5000 |
| ⑦ | | 10,33 | 1,38 | 2,28 | 3180 | |
| Élément de flèche / Auslegerement Jib section / Elemento de flecha Elemento di braccio / Elemento de lança Секция стрелы | | ④ | 6,38 | 1,38 | 2,41 | 3980 |
| | | ⑥ | 5,42 | 1,38 | 2,34 | 2200 |
| | | ⑧ | 5,27 | 1,38 | 2,24 | 1360 |
| | | ⑨ | 5,27 | 1,38 | 2,08 | 990 |
| | | ⑩ ⑪ | 5,26 | 1,38 | 2,03 | 890 |
| | | ⑫ | 1,38 | 1 | 2,23 | 590 |
| | | 1,68 | 1,57 | 0,59 | 330 | |

| | | | L (m) | l (m) | h (m) | kg (+/- 5%) | |
|---|---|---|----------|--|--|--|--|
| Chariot / Laufkatze Trolley / Carrello Carro / Carro-distribuidor Тележка |  |  | 2,63 | 1,75 | 1,58 | 1215 | |
| Moufle / Hubflasche Pulley block / Aparejo Bozzello / Cadernal Полиспаст |  |  | 1,89 | 0,8 | 3,18 | 1415 | |
| Chariot / Laufkatze Trolley / Carrello Carro / Carro-distribuidor Тележка |  |  | 4,2 | 1,8 | 1,5 | 1460 | |
| Moufle / Hubflasche Pulley block / Aparejo Bozzello / Cadernal Полиспаст |  |  | 2,3 | 0,33 | 2,95 | 1310 | |
| Chariot / Laufkatze Trolley / Carrello Carro / Carro-distribuidor Тележка |  |  | 2,1 | 1,8 | 1,5 | 780 | |
| Moufle / Hubflasche Pulley block / Aparejo Bozzello / Cadernal Полиспаст |  |  | 1,52 | 0,33 | 3,05 | 810 | |
| Nacelle de chariot/ Arbeitsbühne an der Laufkatze Trolley inspection platform / Gondola de carro Navicella-carrelino/ Cesta do carro Платформа тележки |  | | 0,96 | 1,05 | 2,12 | 55 | |
| Рулоне / Kranturm / Crane tower Mástil / Torre / Torre Башня крана | | | | | | | |
| T 851 |  |  | 2,45 m | 11,18 | 4,84 | 5,8 | 15750 |
| K 85/K 85-2 |  |  | 2,45 m | 2,22 | 3,25 | 2,5 | 3600 |
| KM 850.10B KM 850.14B KMT 850.10A KMT 850.14A K 88/K 85A2 KM 880.10A KMT 850.10C |  |  | 2,45 m | 10,32 10,32 5,32 5,32 5,32 5,41 3,65 | 2,54 2,54 2,54 2,54 2,51 2,53 2,54 | 2,51 2,51 2,51 2,51 2,51 2,53 2,51 | 10070 11190 5450 5990 8290 8370 4230 |
| Pieds de scellement / Verankerungsfüße Fixing angles / Pie de empotramiento Montante da annegare / Angulos fixadores анкера |  | P 854A P 880A | 0,9 1 | 0,9 1 | 1,5 1,87 | 940 1605 | |
| 1/2 Bras de croix / 1/2 Fundamentkruzträger 1/2 Cross girder / 1/2 Braço en cruz 1/2 Braccio croce / 1/2 Braço da cruz 1/2 Поперечная балка |  | ZY 854 | 5,7 | 0,98 | 2,27 | 6430 | |
| Bras de croix / Fundamentkruzträger Cross girder / Braço en cruz Braccio croce / Braço da cruz Поперечная балка |  | ZY 854 | 11,9 | 1,42 | 2,27 | 14000 | |

Mécanismes / Triebwerke / Mechanisms / Mecanismos / Meccanismi
 Mecanismos / Механизмы

| 400 V - 50 Hz | | | | | | | | | | | | | ch - PS hp | kW | |
|---------------|-----------------------|------------------------|---|----|------|-------|------|--------|---------|------|------|-----|---------------|--------|-------|
| | 150 HPL™ 100 | m/min | 28 | 35 | 48,5 | 81 | 98,5 | 14 | 17,5 | 24,5 | 42 | 49 | 150 | 110 | 532 m |
| | | t | 20 | 15 | 10 | 5 | 3,6 | 40 | 30 | 20 | 10 | 8,1 | | | |
| | 270 LVF 100 GH Optima | m/min | 53 | 69 | 96 | 125,5 | 133 | 26 | 34,5 | 48 | 66,5 | 270 | 200 | 1063 m | |
| | | t | 20 | 15 | 10 | 5 | 3,5 | 40 | 30 | 20 | 10 | | | | |
| | 15 DVF 16 Optima | m/min | 0 → 33 (40 t) 0 → 50 (20 t) 0 → 67 (10 t) 0 → 100 (2,5 t) | | | | | 15 | 11 | | | | | | |
| | RVF 174 Optima+ | tr/min U/min rpm | 0 → 0,7 | | | | | 4 x 10 | 4 x 7,5 | | | | | | |
| | | | | | | | | | | | | | | | |

| 400 V (+10% -10%) 50 Hz | 150 HPL™ : 170 → 110 kVA 270 LVF GH : 266 → 158 kVA |
|-------------------------|--|

| | FR | DE | EN | ES | IT | PT | RU |
|--|--|--|---|---|---|--|---|
| | Profil de vent suivant EN 14439 C25-D25 | Windbedingungen gemäss EN 14439 C25-D25 | Wind conditions according to EN 14439 C25-D25 | Conformidad de los condiciones de viento EN 14439 C25-D25 | Condizioni del vento secondo EN 14439 C25-D25 | Perfil de vento conforme EN 14439 C25-D25 | Ветровой режим в соответствии с EN 14439 C25-D25 |
| | Appel de flèche | Auslegerüberhöhung | Jib elevation | Elevación de la flecha | Inclinazione braccio | Desvio da lança | подъем стрелы |
| | Équipements standards | Standardausrüstungen | Standard equipment | Equipamiento de serie | Equipaggiamento standard | Equipamento de série | Стандартное оборудование |
| | Équipements optionnels | Sonderausrüstungen | Options | Equipamiento opcional | Equipaggiamento in opzione | Equipamento opcional | Дополнительное оборудование (опция) |
| | Fonction Potain Plus : Courbes de charges Plus | Funktion Potain Plus: Plus-Lastkurven | Potain Plus function: Plus load curves | Función Potain Plus: Diagrama de cargas Plus | Funzione Potain Plus: Curve di carico Plus | Função Potain Plus: Diagrama de cargas Plus | Функция контроля мощности Potain Plus: Диаграммы грузоподъемности Plus |
| | Hauteurs sous crochet associées aux courbes de charges Plus | Hakenhöhen mit Plus-Lastkurven | Hook heights with Plus load curves | Altura bajo gancho, usando el diagrama de cargas Plus | Altezze sotto gancho con curve di carico Plus | Altura livre, utilizando o diagrama de cargas Plus | Высота под крюком для диаграмм грузоподъемности Plus |
| | Réactions en service | Reaktionskräfte in Betrieb | Reactions in service | Reacciones en servicio | Reazioni in servizio | Reacções em serviço | Реакция при работе |
| | Réactions hors service | Reaktionskräfte außer Betrieb | Reactions out of service | Reacciones fuera de servicio | Reazioni fuori servizio | Reacções fora de serviço | Реакция в покое |
| | Poids total du lest | Ballast-Gesamtwegicht | Total ballast weight | Peso total del lastre | Peso totale della zavorra | Peso total do lastro | Общий вес балласта |
| | Cadre d'ancrage serré | Fester Verankerungsrahmen | Tightened anchorage frame | Marco de anclaje de apriete | Quadro di ancoraggio stretto | Quadro de amarração apertado | Прикрепленная анкерная рама |
| | Cadre d'ancrage desserré | Looser Verankerungsrahmen | Loosened anchorage frame | Marco de anclaje de desapriete | Quadro di ancoraggio allentato | Quadro de amarração solto | Отсоединенная анкерная рама |
| | Camion 13,4 m | Lkw 13,4 m | Lorry 13,4 m | Camión 13,4 m | Camion 13,4 m | Camião 13,4 m | Рзусовой автомобиль 13,4 м |
| | Conteneur High Cube 40', et/ou Flat Rack 20' | Container High Cube 40', und/oder Flat Rack 20' | Container High Cube 40', and/or Flat Rack 20' | Contenedor High Cube 40', y/o Flat Rack 20' | Container High Cube 40', e/o Flat Rack 20' | Contentor High Cube 40', e/ou Flat Rack 20' | 40-футовый контейнер повышенной вместимости High Cube, и/или 20-футовая открытая платформа Flat Rack |
| | Levage | Heben | Hoisting | Elevación | Sollevamento | Elevação | Подъем |
| | Distribution | Katzfahren | Trolleying | Distribución | Distribuzione | Distribuição | Перемещение по стреле |
| | Orientation | Schwenken | Slewing | Orientación | Rotazione | Rotação | Поворот |
| | Translation | Kranfahren | Travelling | Traslación | Traslazione | Translação | Перемещение крана |
| | Puissance requise | Erforderliche Leistung | Required power | Potencia Necesaria | Potenza richiesta | Potência Necessária | Потребляемая мощность |
| | Fonction Power Control : vitesses treuils adaptées à la puissance disponible | Funktion Power Control: Geschwindigkeiten der Triebwerke werden an die verfügbare Leistung angepasst | Power Control Function: winch speeds adapted to the available power | Función Power Control: marchas de los cabrestantes adaptadas a la potencia disponible | Funzione Power Control: velocità degli argani adattate alla potenza disponibile | Função Power Control: velocidades de guincho adaptadas à potência disponível | Функция контроля мощности Power Control: регулировка скорости лебедок в зависимости от доступной мощности |
| | Nous consulter | Auf Anfrage | Consult us | Consultarnos | Consultateci | Consultar-nos | Проконсультируйтесь у нас |
| | Document commercial non contractuel. Pour toute information technique se référer à la notice correspondante. | Unverbindliches Vertriebsdokument. Für technische Informationen, siehe die entsprechenden Anweisungen. | This commercial document is not legally binding. For any technical information, please refer to the corresponding instructions. | Documento comercial no contractual. Para cualquier información técnica, ver la noticia correspondiente. | Documento commerciale non vincolante, per tutte le informazioni tecniche fare riferimento al catalogo istruzioni. | Documento comercial não contratual. Para qualquer informação técnica complementar consultar as respectivas instruções. | Этот коммерческий документ не является юридически обязательным. Для получения технической информации, см. соответствующие инструкции. |

