



## Rectangular Boom Inspection Procedure

This program was designed to establish a standard field procedure to check and inspect booms for squareness, sweep, twist, camber, flatness or convex / concave conditions.

This procedure pertains to Grove and GMK built booms. Fabricated trapezoidal booms, formed trapezoidal booms, rectangular booms, rectangular swingaways, triangular swingaways and AFrame jibs.

This boom inspection data form will be used to record all measurements taken while performing the inspection.

**Note: All calculations will be done by Manitowoc Product Support**

**Note:** Anytime you are using the gauge blocks, record the thickness of the block used in the appropriate space on the form. Always use gauge blocks large enough to ensure the string does not touch the boom section. **All check dimensions recorded will include the gauge block thickness.**

**Note:** All measurements are taken from the rear of the section to the front, with the exception of checking for a twist in an A-Frame jib or a swingaway. You must check A-Frame jibs and swingaways by leveling the front of the section and taking the check dimension at the rear. Because of the angle of inclination of the main chords, the front end is narrower than the width at the rear of the section.

### Tools Required

Quantity 1 - 4 Foot Level

Quantity 1 - Large Square ( 3' x 4' )

Quantity 2 - Small Squares ( 24" x 16" )

Quantity 2 - Vise Grip Clamps

Quantity 1 - 6" scale

Quantity 1 - 12' Tape Measure

Quantity 2 - Gauge Blocks or Rods ( Same Thickness )

Mason String

## Definitions

**Trapezoidal Boom** - A four sided boom with only 2 sides being parallel



**Rectangular Boom** - A four sided boom having edges, surfaces, or faces that are right angles



**GMK Style / Megaform** - A six sided boom made from two formed channels. The top half has 90° bends and the bottom half has multiple bends.



**A-Frane Jib** - A boom extension suspended by cables

**Swingaway** - A boom extension that is pinned directly to the main boom nose

**Sweep** - To curve to the right or left, a deviation from being parallel. Larger than the gauge block on one side and smaller than the gauge block on the other side.

**Camber** - To arch slightly, to curve upward or downward

**Squareness** - To test for a deviation from a right angle

**Twist** - To rotate while taking a curving path or direction

**Convex** - Arched up or bulging out condition

**Concave** - Arched inward or curving in condition

**O. D. Width** - Outside dimension measured from outside of left side plate to outside of right side plate

**O. D. Height** - Outside dimension measured from outside edge of top plate to outside edge of bottom plate

**Distortion** - To twist out of normal or original shape

**Maximum Deviation** - The difference between a fixed number (gauge block) and the check dimension

**Check Dimension** - The actual measurements taken at various places on boom

**Strut** - Tubing that is welded between main chords of A-Frame jibs

**Gauge Blocks** - Are blocks, being the same size, from which measurements are being taken

**Main Chord** - Main support tube that runs the full length of jibs and swingaways

**Lacing** - Tubing that is welded between the main chords of swingaways

## Serial Number and Part Number Locations On Booms, Swingaways and Jib Booms

Machine component serial numbers and part numbers are required for us to supply repair procedures for major weldments.

We have attached a list of major components with serial number locations.

**Note:** Part number is on opposite side of the serial number.

The numbers are steel stamped into the major components in the approximate locations shown.

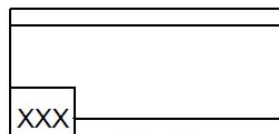

Fig. 1  
Rectangular Boom  
Left Forward  
Bottom Corner

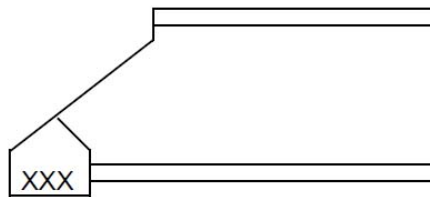

Fig. 2  
Trapezoidal Boom  
Bottom Left  
Forward Bottom Corner

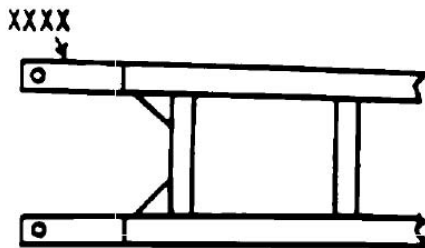

Fig. 3  
A-Frame Jib

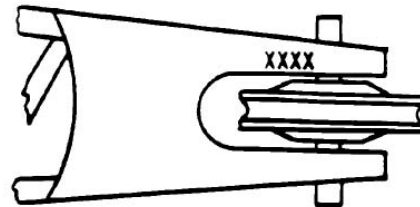

Fig. 4  
Lattice Swingaways  
and Fixed Lattice  
Boom Extensions

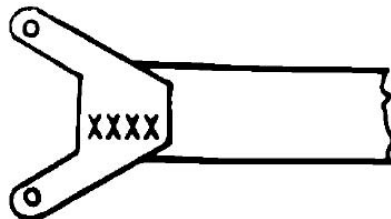

Fig. 5  
Stevedore, IND 24, AP 308 and AP 206  
Jib-Top Side of Trunnion Block

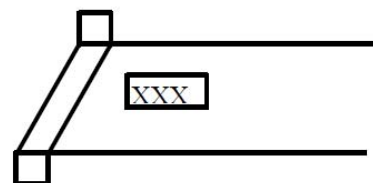
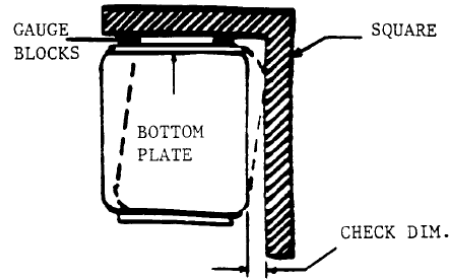

Fig. 6  
GMK Style / Megaform

## Rectangular Boom Squareness

Chkd. By \_\_\_\_\_ Model \_\_\_\_\_  
 Date \_\_\_\_\_ Serial # \_\_\_\_\_  
 Distributor \_\_\_\_\_  
 Boom Section Being Checked \_\_\_\_\_  
 Record Part Number of Boom Section \_\_\_\_\_  
 Record Serial Number of Boom Section \_\_\_\_\_

1. Select 5 stations along the length of the boom where check dimensions are to be taken. Station 1 being at the rear.
2. Now with the bottom plate up. Place the gauge blocks on the outside edge of the bottom plate.
3. Put a square across the blocks and against the side plate.
4. Measure the gap between the square and the boom and record on this form.
5. Check the other side at the same stations following the above procedure.



Left Side	Right Side	Rear						Front				
Sta1 _____	_____	<table style="width: 100%; border-collapse: collapse;"> <tr> <td style="width: 20%; text-align: center;">Sta1</td> <td style="width: 20%; text-align: center;">Sta2</td> <td style="width: 20%; text-align: center;">Sta3</td> <td style="width: 20%; text-align: center;">Sta4</td> <td style="width: 20%; text-align: center;">Sta5</td> </tr> </table>					Sta1	Sta2	Sta3	Sta4	Sta5	
Sta1	Sta2	Sta3	Sta4	Sta5								
Sta2 _____	_____											
Sta3 _____	_____											
Sta4 _____	_____											
Sta5 _____	_____											

## Rectangular Boom Twist

1. Place the boom bottom up.
2. Place a level across the bottom plate at the rear and level the boom.
3. Once the rear is level, take the 4' level to the front of the boom and place it across the bottom plate.
4. Lift either end of the level one way or the other until the bubble is level.
5. Now measure the distance between the level and the bottom plate.
6. Record the check dimension as twist.
7. To determine direction of twist, stand at the rear looking toward the front. If you measured the distance between the level and the bottom plate on the left side, then the boom twists to the left. If the check dimension was taken on the right, then the boom twists to the right.
8. Record the direction of twist on this form.

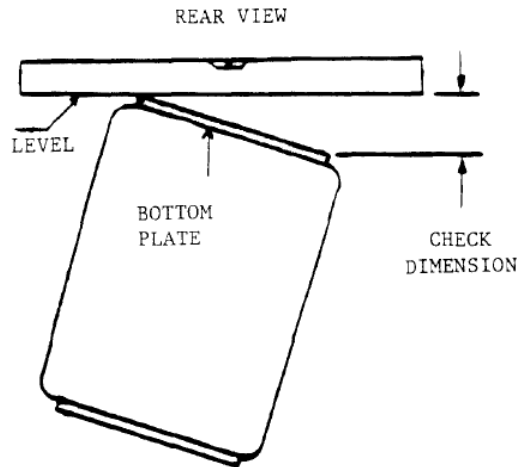

Record Check Dimension as Twist \_\_\_\_\_  
 Record Direction of Twist \_\_\_\_\_

## Rectangular Boom Sweep

Chkd. By \_\_\_\_\_ Model \_\_\_\_\_  
 Date \_\_\_\_\_ Serial # \_\_\_\_\_  
 Distributor \_\_\_\_\_  
 Boom Section Being Checked \_\_\_\_\_  
 Record Part Number of Boom Section \_\_\_\_\_  
 Record Serial Number of Boom Section \_\_\_\_\_  
 Record Length of Boom Section \_\_\_\_\_

1. Place the gauge blocks against Record the outer edge of the bottom rail, Minimum one at each end.
2. Draw the string tightly over the blocks.
3. Measure the thickness of the gauge blocks used and record on this form.
4. Measure the distance between the various points along the string string and the side of the bottom rail at
5. Record the maximum check dimension on the form.
6. Now measure the distance from the rear of the boom section to where the maximum check dimension was found. Record that dimension on this form.
7. Repeat this procedure for the other rail and record the minimum dimension on this form.
8. To obtain a true sweep measurement, one side will be greater than the gauge blocks and the other side will be smaller than the gauge blocks. The sweep must be uniform throughout the entire length of the boom section and free of any kinks or deviations.

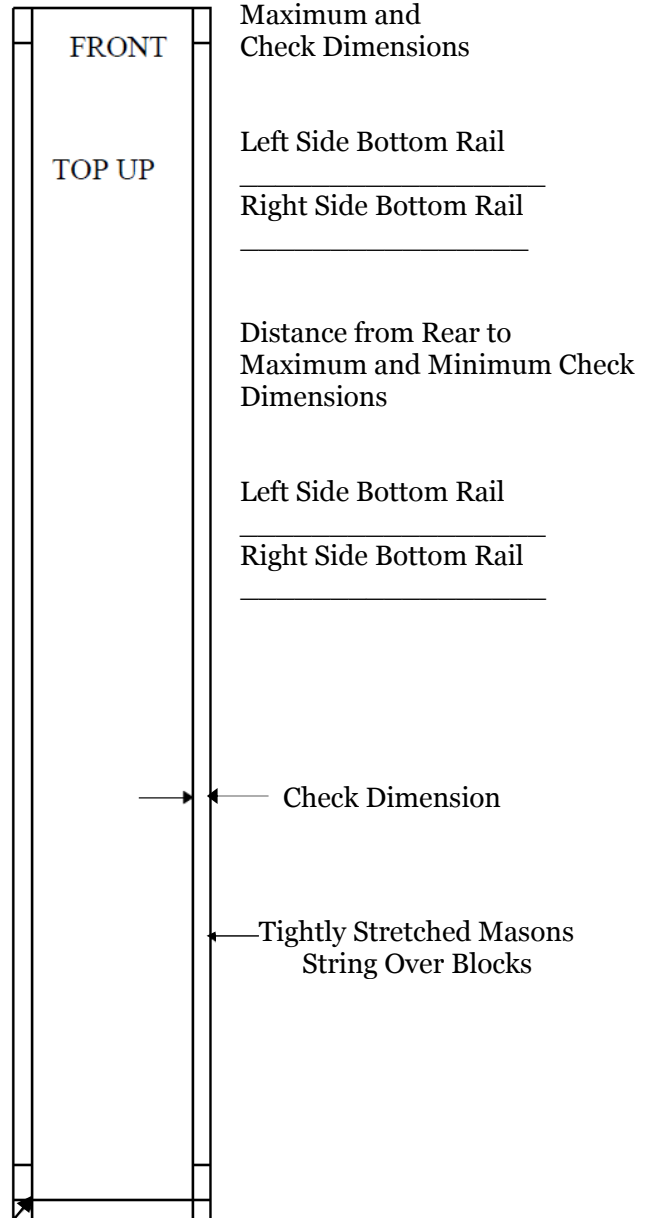

Record thickness of round or square gauge blocks \_\_\_\_\_

# Rectangular Boom Camber

Chkd. By \_\_\_\_\_ Boom Model \_\_\_\_\_  
Date \_\_\_\_\_ Boom Serial # \_\_\_\_\_  
Distributor \_\_\_\_\_  
Boom Section Being Checked \_\_\_\_\_  
Record Part Number of Boom Section \_\_\_\_\_  
Record Serial Number of Boom Section \_\_\_\_\_

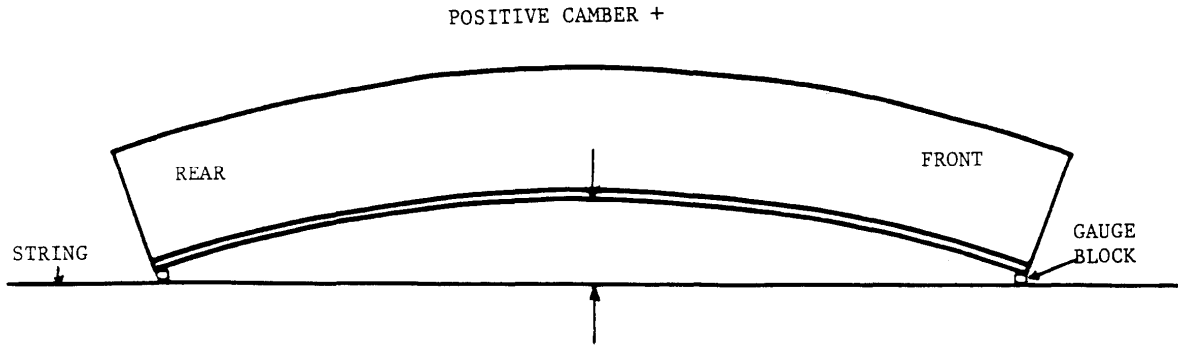

## Check Dimension

Record Camber Dimension Left Side \_\_\_\_\_  
Record Camber Dimension Right Side \_\_\_\_\_  
Record Distance from Rear to Max. Check Dimension Left Side \_\_\_\_\_  
Record Distance from Rear to Max. Check Dimension Right Side \_\_\_\_\_  
Record Thickness of Round or Square Gauge Blocks \_\_\_\_\_

1. Lay boom on it's side.
2. Place gauge blocks on bottom rail at each end and pull string tightly over them.
3. Measure the distance between string and bottom rail at various points between both gauge blocks.
4. Record maximum check dimension.

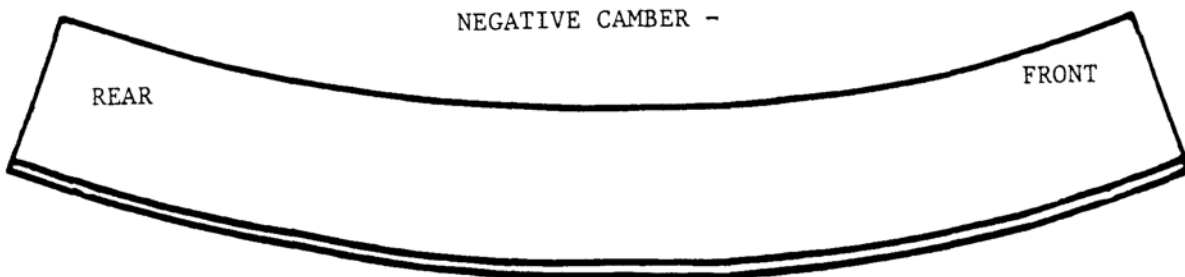

## Rectangular Boom Concave/Convex

Chkd. By \_\_\_\_\_ Boom Model \_\_\_\_\_  
 Date \_\_\_\_\_ Boom Serial # \_\_\_\_\_  
 Distributor \_\_\_\_\_  
 Boom Section Being Checked \_\_\_\_\_  
 Record Part Number of Boom Section \_\_\_\_\_  
 Record Serial Number of Boom Section \_\_\_\_\_

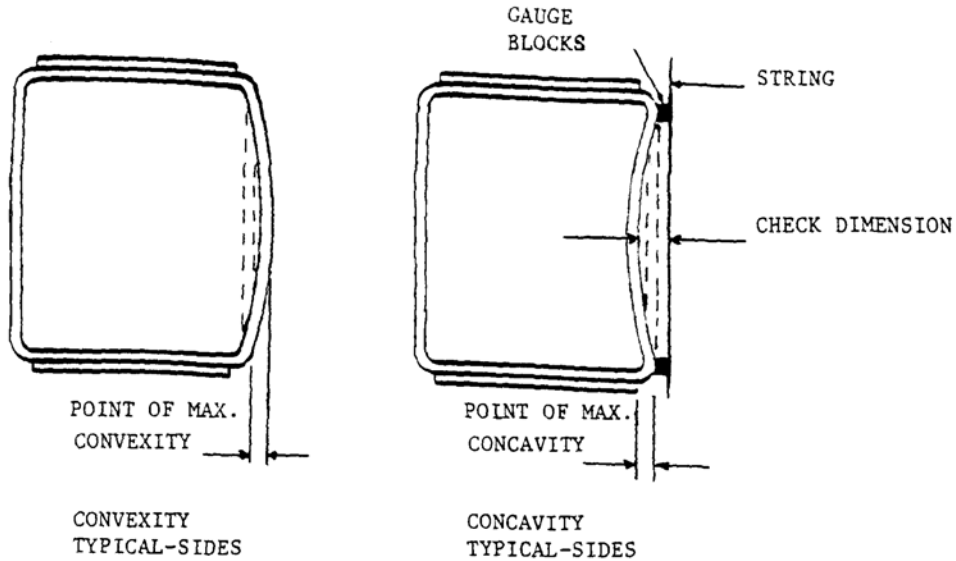

Concave / Convex

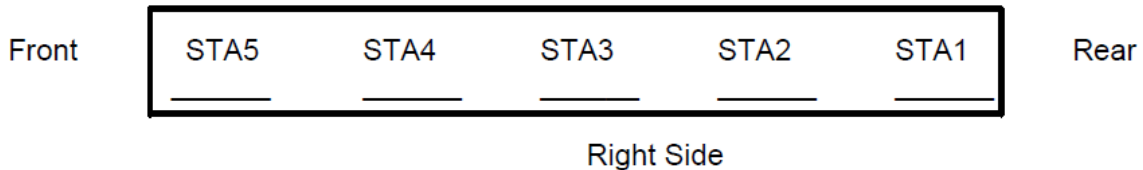
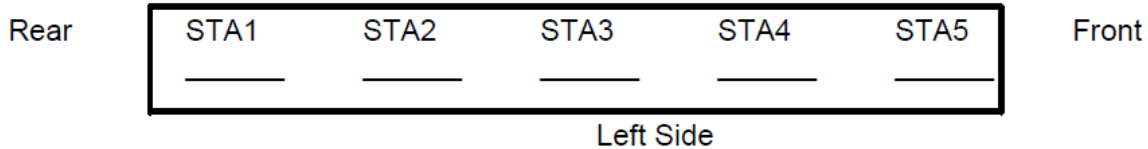

1. Select 5 stations at which to take measurements. Station 1 being at the rear and station 5 at the front.
2. Place gauge blocks on the side plate close to the outer edge and place a straight edge across them.
3. Measure the distance between the bottom of the straight edge and the boom side plate.
4. Find the maximum check dimension and record on form in the box under STA 1,2,3,etc.

Record thickness of gauge blocks \_\_\_\_\_

## Rectangular Boom O.D. Width/Height

Chkd. By \_\_\_\_\_ Boom Model \_\_\_\_\_  
 Date \_\_\_\_\_ Boom Serial # \_\_\_\_\_  
 Distributor \_\_\_\_\_  
 Boom Section Being Checked \_\_\_\_\_  
 Record Part Number of Boom Section \_\_\_\_\_  
 Record Serial Number of Boom Section \_\_\_\_\_

O.D. Width

O.D. Height

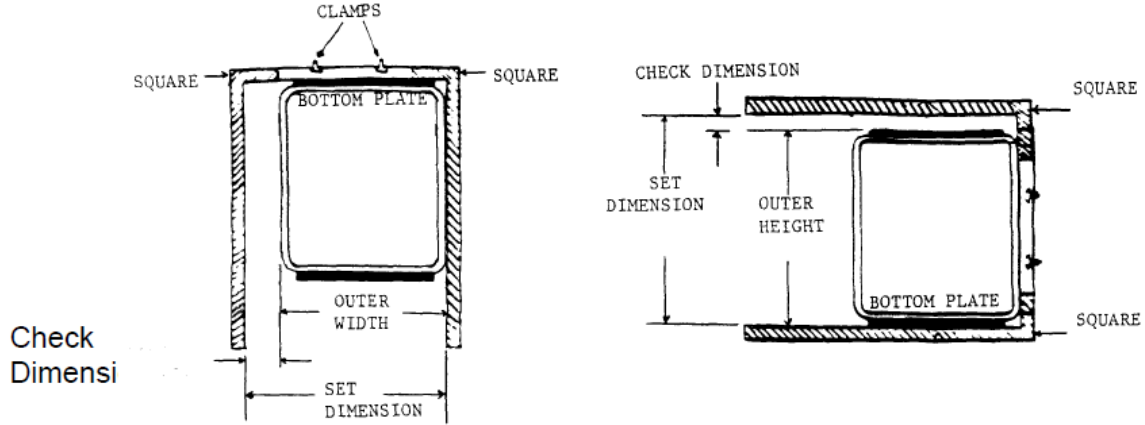

Conventional Boom Height-Width Record

1	2	3	4	5	6	7	8	9	10	11	12
Select 12 Stations at which to take measurements											

**O.D. Width**

1. \_\_\_\_\_
2. \_\_\_\_\_
3. \_\_\_\_\_
4. \_\_\_\_\_
5. \_\_\_\_\_
6. \_\_\_\_\_
7. \_\_\_\_\_
8. \_\_\_\_\_
9. \_\_\_\_\_
10. \_\_\_\_\_
11. \_\_\_\_\_
12. \_\_\_\_\_

1. Clamp 2 squares together making sure squares are square with each other.
2. Make the distance between the squares about 1/2" to 1" larger than the width or height, whichever one is being measured. Record the distance between squares as the set dimension on this form.
3. To check the O.D. width place the squares across the bottom plate and against one side of the boom.
4. Measure the distance between the square and boom side plate at various places to find the widest point. Record this check dimension on this form for this station.

**O.D. Height**

1. \_\_\_\_\_
2. \_\_\_\_\_
3. \_\_\_\_\_
4. \_\_\_\_\_
5. \_\_\_\_\_
6. \_\_\_\_\_
7. \_\_\_\_\_
8. \_\_\_\_\_
9. \_\_\_\_\_
10. \_\_\_\_\_
11. \_\_\_\_\_
12. \_\_\_\_\_

Record Set Dimension To O.D. Width

\_\_\_\_\_

5. Repeat procedure for all stations the entire length of the boom.
6. To check O.D. Height measure from top and bottom plate instead of side plate to side plate.

Record Set Dimension To O.D. Height

\_\_\_\_\_