

# Shuttlelift CD5540F (Dual Fuel)

## Product Guide



### Features

- 13,6 t (15 USt) capacity three-section boom with 12,5 m (41 ft) outreach
- 4,6 m (15 ft) offsettable swingaway extension
- 9072 kg (20,000 lb) deck carrying capacity
- Available with dual fuel engine only



# Features

## Outriggers

The CD5540F is equipped with single-position oblique style outriggers..



## Cab

Both models come equipped with a **standard** open air cab shell with overhead safety glass.

An **optional** enclosed cab with front, right and rear glass, a split (two-piece) hinged door with sliding glass. Front windshield wiper, heater and defroster fan is available.



## Steering

**Standard** steering modes on the 5540F is two-wheel, four-wheel, and crab steer with an option for electronic self-alignment.



## Dual Fuel engine

G.M. 4,3 L V-6 EFI dual fuel (gasoline / L.P.) rated at 69,3 kW (93 bhp) at 2500 rpm.



## Boom

A 12,5 m (41 ft) main boom comes **standard** on the CD5540F. An **optional** fourth main boom section adds 3,4 m (11 ft) additional boom length.

Specifications	4
CD5540F dimensions	7
CD5540F three-section boom working range	8
CD5540F four-section boom working range	9
CD5540F three-section boom load chart	10
CD5540F four-section boom load chart	11
Symbols glossary	15

# Specifications

## Superstructure

### Boom

5,6 m – 12,5 m (18 ft 6 in – 41 ft 0 in) three-section full power boom.

Maximum tip height: 14,1 m (46 ft 3 in)

### \*Optional boom

Manual fourth main boom fly section

Maximum tip height: 17,0 m (56 ft 3 in)

### \*Boom extension

4,6 m (15 ft) offsettable swingaway extension

### Boom nose

Two sheave non-pivoting boom nose

### Boom elevation

Single double acting hydraulic cylinder with integral holding valve.

Elevation: 0° to 69°

### Anti-two block device

Standard anti-two block device, when activated, provides an audible warning to the crane operator and disengages all crane functions whose movement can cause two-blocking.

### Load indicator (wireless LSI)

A simple, effective, and easy to use load moment indicating system used in conjunction with a wireless anti-two block system to assist the operator in efficient operation of the unit within the limits of the load chart.

The display panel displays the hook load, length and angle of the boom, and load radius in Dot Matrix numerical values and provides a load utilization colored bar graph.

If non-permitted conditions are approached the L.M.I. will warn the operator with an audible alarm and a warning light and will lock out those functions that may aggravate the condition.

Standard limit settings can be programmed for boom Angle, load radius, and boom tip height.

### \*Load moment indicator (hard wired LMI)

“Graphics Display” of boom angle, boom length, load radius, and capacity. Operator input to set the limit parameters based on the load chart. Displays color coded light bar and audible alarm with function cut-out if load exceeds the load chart parameters.

### Swing

Ball bearing swing circle with 360° continuous rotation. Hydraulic driven worm gear and pinion. Maximum speed: 2.1 rpm

### Hydraulic system

Four section gear pump providing a system pressure of 241,3 bars (3500 psi)

Combined flow: 333,1 Lpm (88.0 gpm)

Six-section valve bank mounted in dash with direct mechanical linkage for low effort lever control.

Return line filter with full flow by-pass protection and service indicator.

151,4 L (40 gal) hydraulic reservoir with sight level gauge and steel side plating to guard against side impact damage.

### Hoist specifications

Piston motor drive with spring applied / hyd. released brake. Equal speed power up and down.

Drum diameter: 0,25 m (9.75 in)

Maximum hoist single line pull: 5443 kg (12,000 lb)

Maximum hoist single line speed:  
38,4 m/min (126 fpm)

Maximum permissible single line pull:

3402 kg (7500 lb)

(12,7 mm [1/2 in])

Rope length:

(three-section boom) 73,0 m (240 ft)

(four-section boom) 88,4 m (290 ft)



# Specifications

## Carrier



### Frame

High strength alloy steel constructed with integral outrigger housings; front and rear tie-down lugs. 75 ft<sup>2</sup> carrydeck size with 9072 kg (20,000 lb) carrying capacity. Deck coated with anti-skid treatment.



### Outriggers

Front and rear oblique type beams at all four corners with integral holding valves. Outrigger pads form an integral part of the beam. Outrigger pad size 222 mm x 254 mm (8.75 in x 10 in).

Maximum pad load: 162 p.s.i.



### Outrigger controls

Lever controls located on dash panel and operate the beams in pairs from side to side. Level bubble located inside operators compartment. Outrigger monitoring system comes standard (required for North America and Canada).



### Dual Fuel engine

G.M. 4,3 L V-6 EFI dual fuel (gasoline / L.P.) rated at 69,3 kW (93 bhp) at 2500 rpm.



### Operators control station

Frame mounted, open air style control station with cab shell includes all crane functions, driving controls, and overhead safety glass. Other standard equipment include a durable weather resistant seat with seat belt, hourmeter, sight level bubble, and fire extinguisher. The dash panel includes engine oil pressure gauge, engine water temperature gauge, fuel gauge, transmission low oil and high temperature warning lights, low battery warning light, and brake system low pressure warning light. The LSI (load indicator) receiver is mounted to the top of the dash.



### \*Operators control station enclosed

Includes the standard cab shell with the addition of front, right, and rear glass, a split (two-piece) hinged door with sliding glass.

Front windshield wiper, heater and defroster fan are included.



### Fuel tank capacity

151,4 L (40 gal) all steel construction with steel side plate to guard against side impact.



### Electrical system

One 12V maintenance free battery, 820CCA @ 0°. 63 amp alternator.



### Drive

4 x 2 – Front axle drive with planetary hubs and limited slip differential.



### Steer

Two-wheel, four-wheel, and crab steer

Outside turning radius:

Two wheel steer: 6,55 m (21 ft 6 in)

Four wheel steer: 3,76 m (12 ft 4 in)



### Transmission

I.T.L. synchromesh four-speeds forward and reverse.



### Tires

385/65R 22.5 radial traction tread pneumatic.



### Brakes

Hydraulic actuated internal wet-disc service brakes acting on all four wheels. A dash mounted toggle switch activates the dry disc parking brake on the transmission output yoke with a dash warning light.



### Suspension

**Front:** Rigid mounted to frame.

**Rear:** Provides 1.5° oscillation for use on semi-rough terrain. Axle lock-out must be engaged (locked) whenever picking on rubber or traveling in the crab steer mode. A warning light indicates when the axle lock-outs are engaged.

# Specifications



## Lights

Recessed mounted, includes head, tail, rear work, stop, and turn signals.



## Maximum speed

23,3 km/h (14.5 mph)



## Gradeability (theoretical)

73%....no load

41%.... 9072 kg (20,000 lb) load

## Gross vehicle weight (G.V.W)

12 332 kg (27,186 lb) three-section boom

12 584 kg (27,743 lb) four-section boom

## Miscellaneous standard equipment

Two sheave, "Quick Reeve" style hook block; 13,6 t (15.0 USt); Back-up alarm

Lifting and tie down lugs

Outrigger motion alarm

## CD5540F

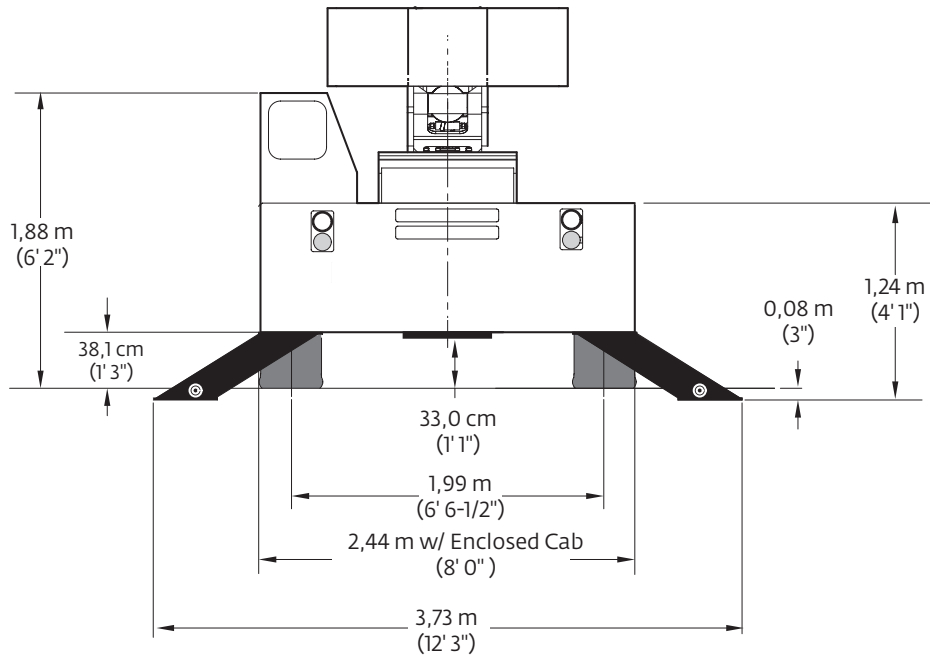
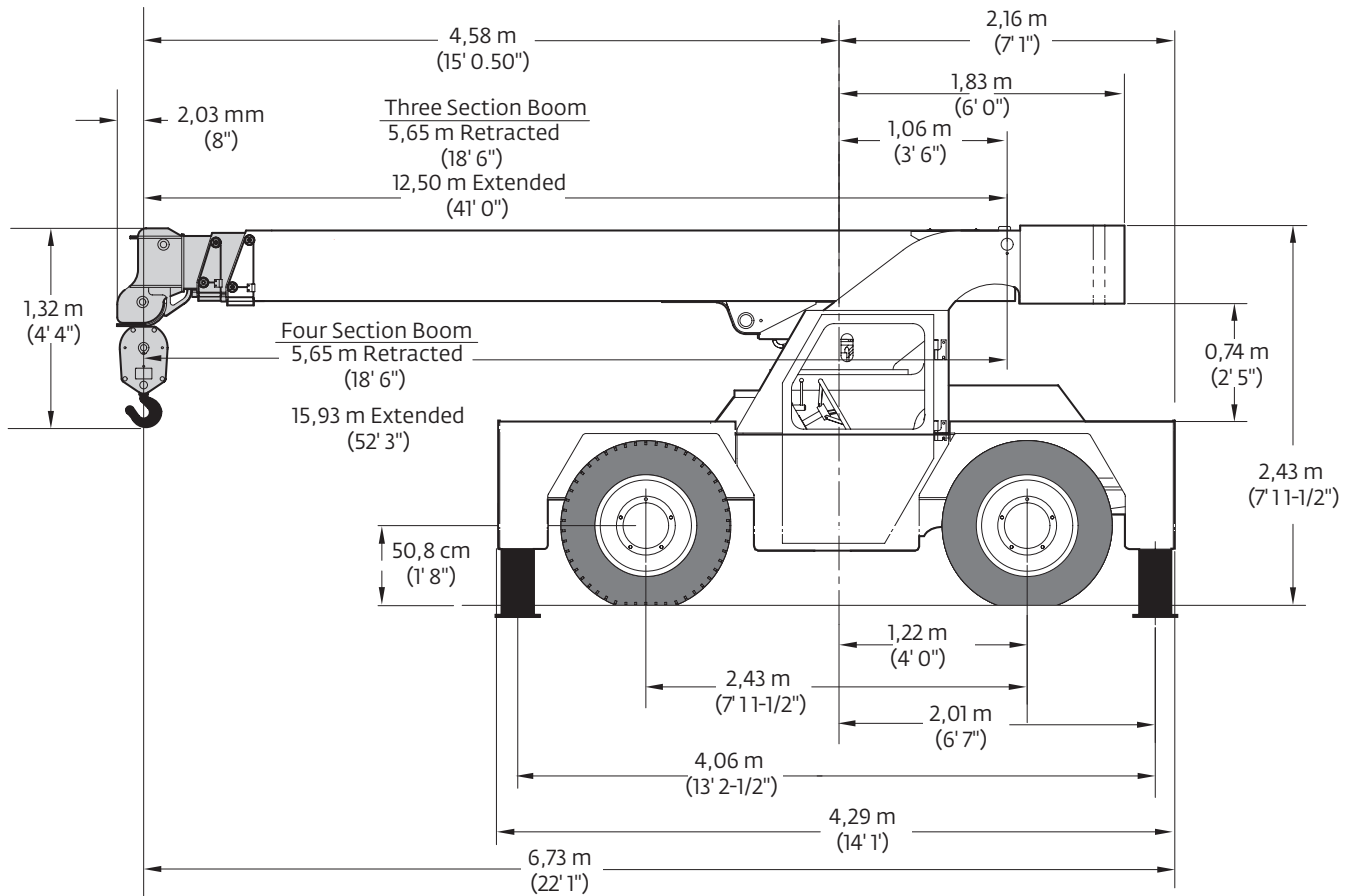

THIS CHART IS ONLY A GUIDE AND SHOULD NOT BE USED TO OPERATE THE CRANE.

The individual crane's load chart, operating instructions and other instructional plates must be read and understood prior to operating the crane.

# Range diagram

## CD5540F (Three-section boom)

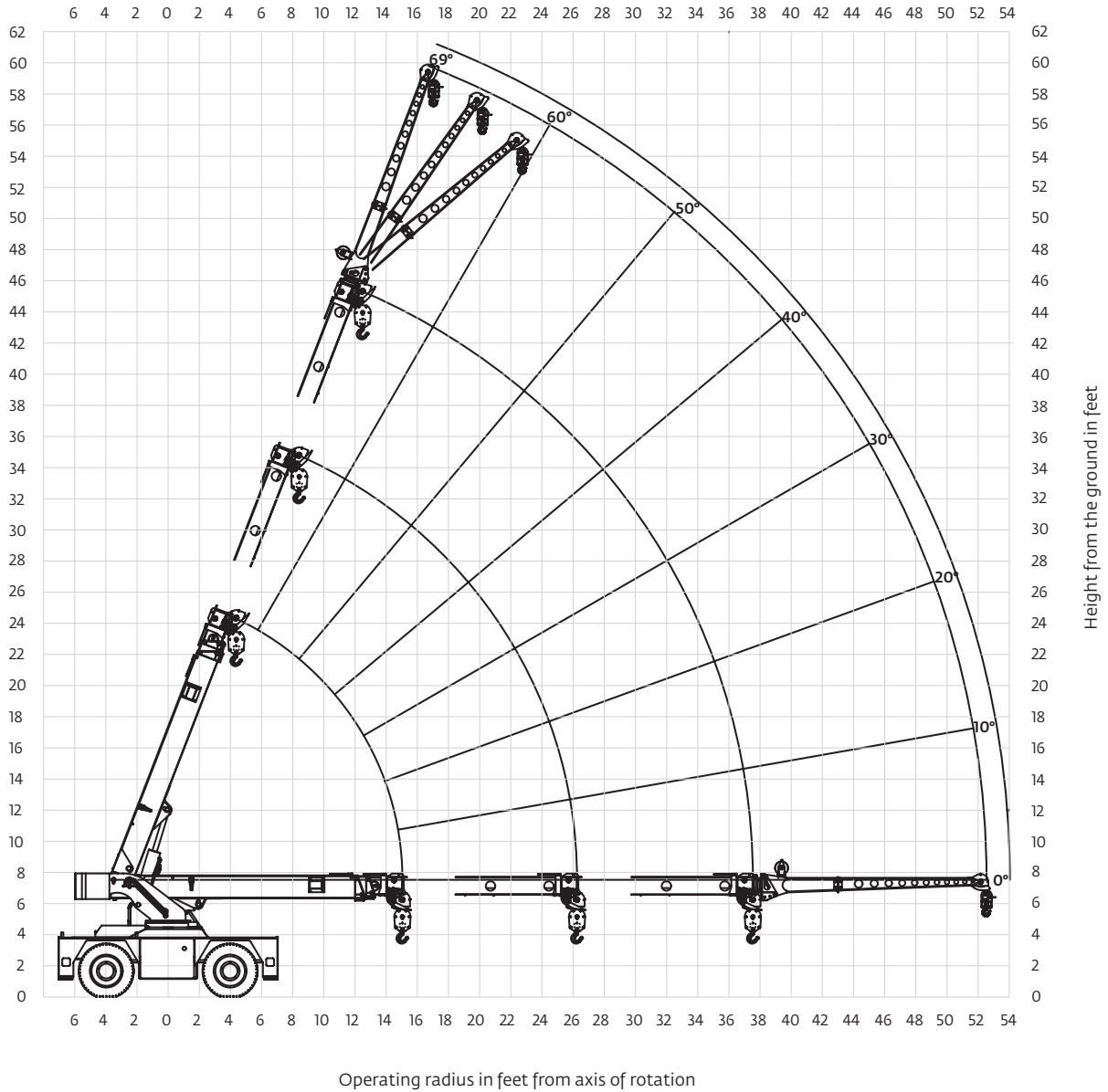

THIS CHART IS ONLY A GUIDE AND SHOULD NOT BE USED TO OPERATE THE CRANE.  
The individual crane's load chart, operating instructions and other instructional plates must be read and understood prior to operating the crane.



# Range diagram

## CD5540F (Four-section boom)

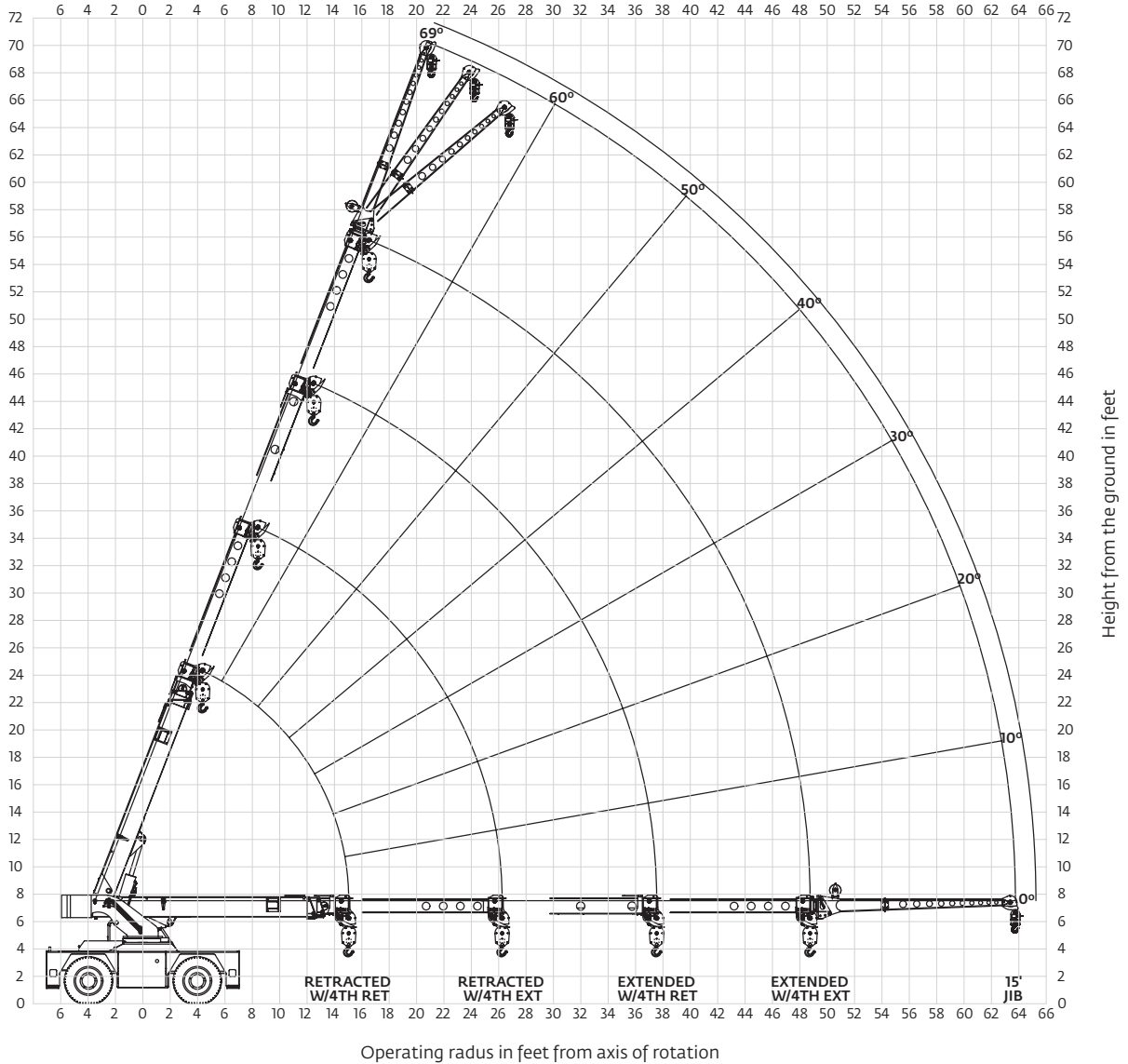

*THIS CHART IS ONLY A GUIDE AND SHOULD NOT BE USED TO OPERATE THE CRANE.*

*The individual crane's load chart, operating instructions and other instructional plates must be read and understood prior to operating the crane.*

# Load chart

## CD5540F (Three-section boom)

	RADIUS (ft)	ON OUTRIGGERS (lb)		ON RUBBER (lb)		
		F/R	360°	F/R	360°	
MAIN BOOM	6.0	30,000	30,000	17,000	17,000	
	8.0	26,200	26,200	13,500	14,600	
	10.0	22,300	22,300	10,700	10,880	
	12.0	18,600	18,600	8710	8100	
	14.0	14,800	14,800	7210	6000	
	15.0	13,000	13,000	6600	5250	
	16.0	12,200	12,200	6060	4760	
	18.0	10,800	10,800	5120	3900	
	20.0	9630	9180	4370	3190	
	22.0	8640	7480	3710	2660	
	24.0	7790	6210	3070	2200	
	26.0	7040	5310	2620	1820	
	28.0	6420	4740	2260	1530	
	30.0	5700	4290	1990	1320	
	32.0	5060	3920	1790	1160	
	34.0	4510	3580	1610	1040	
	36.0	4020	3260	1460	930	
	37.5	3700	3060	1370	860	
	JIB	40.0	3480	2860	1270	800
		42.0	3310	2700	1190	740
44.0		3130	2560	1120	690	
46.0		2960	2410	1040	640	
48.8		2710	2210	930	570	
52.5		2390	1940	790	480	

MAIN BOOM ANGLE (deg)	JIB STRUCTURAL CAPACITIES (lb)		
	0°	15°	30°
69	6000	3900	2800
65	5000	3500	2550
60	4300	3150	2350
55	3800	2850	2200
50	3400	2600	2100
45	3050	2400	2000
40	2800	2250	1950
35	2600	2150	1900
30	2400	2080	1850
25	2300	2050	-
20	2200	2000	-
15	2100	1950	-
10	2050	-	-
5	2020	-	-
0	2000	-	-

**NOTES:**

JIB CAPACITY IS LIMITED BY BOTH STRUCTURAL CAPACITY CHART AND MAIN CAPACITY CHART.

SHADED AREAS ARE GOVERNED BY STRUCTURAL STRENGTH, DO NOT RELY ON TIPPING.

OPERATION OF THIS EQUIPMENT IN EXCESS OF RATING CHARTS AND DISREGARD OF INSTRUCTIONS IS DANGEROUS AND VOIDS WARRANTY.

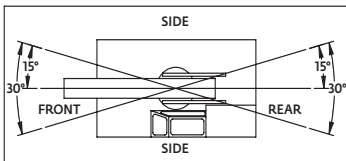

REDUCTION CHART		
	FROM MAIN BOOM RATINGS	FROM JIB RATINGS
MAIN BLOCK	210 lb	N/A
HOOK & BALL	100 lb	100 lb
JIB, STOWED	0 lb	N/A
JIB, DEPLOYED	700 lb	0 lb

RIGGING CHART	
1-PART 0 - 7500 lb	4-PART 0 - 30,000 lb
WIRE ROPE: 1/2 in diameter Minimum breaking strength 26,250 lb	

1) The rated loads are the maximum lifting capacities as determined by operating radius only. Any combination of boom lengths and angles may be used to obtain operating radius. The operating radius is the horizontal distance from a projection of the axis of rotation to the supporting surface, before loading, to the center of vertical hoist line or tackle with load applied.

2) The rated loads shown on outriggers do not exceed 85% of actual tipping. The rated loads shown on rubber do not exceed 75% of actual tipping. These ratings are based on freely suspended loads with the crane leveled, standing on a firm, uniform supporting surface. Practical working loads depend on supporting surface, operating radius and other factors affecting stability. Hazardous surroundings, climatic conditions, experience of operator and proper training must be taken into account by the operator.

3) The weights of all load handling devices, such as hooks, hook blocks, slings, etc., except the hoist rope, shall be considered as part of the load. See reduction chart.

4) Ratings on outriggers are with outriggers fully extended.

5) Ratings on rubber depend on tire capacity, condition of tires and proper inflation pressure (120 psi). Loads on rubber may be transported at a maximum speed of 2.5 mph on a smooth, hard, level surface with the boom retracted to the shortest length possible and centered over the front.

6) For operating radius not shown, use load rating of next larger radius.

7) The maximum combined total boom and deck load is 16,000 lb. The maximum deck load only is 20,000 lb.

8) Do not induce any external side loads to boom or jib.

1302442

THIS CHART IS ONLY A GUIDE AND SHOULD NOT BE USED TO OPERATE THE CRANE.

The individual crane's load chart, operating instructions and other instructional plates must be read and understood prior to operating the crane.

## CD5540F (Four-section boom)

RADIUS (ft)	4TH RETRACTED				RADIUS (ft)	4TH EXTENDED			
	ON OUTRIGGERS (lb)		ON RUBBER (lb)			ON OUTRIGGERS (lb)		ON RUBBER (lb)	
	F/R	360°	F/R	360°		F/R	360°	F/R	360°
6.0	30,000	30,000	17,000	17,000	6.0	-	-	-	-
8.0	26,200	26,200	13,500	14,600	8.0	11,000	11,000	11,000	11,000
10.0	22,300	22,300	10,700	11,000	10.0	10,700	10,700	10,700	10,700
12.0	18,600	18,600	8710	7650	12.0	9250	9250	9250	9250
14.0	14,800	14,800	7210	5480	14.0	8290	8390	7760	7500
15.0	13,000	13,000	6600	4890	15.0	8200	8200	7150	6080
16.0	12,200	12,200	6060	4500	16.0	8110	8110	6610	5510
18.0	10,800	10,600	4950	3750	18.0	7950	7950	5680	4500
20.0	9630	8630	3980	3080	20.0	7820	7820	4730	3560
22.0	8640	7350	3230	2460	22.0	7710	7710	3980	3000
24.0	7790	6460	2720	1990	24.0	7630	7270	3410	2520
26.0	6800	5700	2360	1610	26.0	7100	6330	2940	2150
28.0	5820	5040	2100	1410	28.0	6590	5420	2550	1840
30.0	5020	4420	1880	1220	30.0	5710	4760	2190	1580
32.0	4400	3950	1650	1070	32.0	5180	4080	1880	1360
34.0	3930	3570	1460	920	34.0	4680	3570	1600	1160
36.0	3510	3190	1280	770	36.0	4250	3190	1370	990
37.5	3210	2890	1180	680	37.5	3830	2970	1240	880
40.0	2950	2600	1070	610	40.0	3400	2700	1070	740
42.0	2760	2430	970	550	42.0	3150	2490	960	630
44.0	2590	2250	890	500	44.0	2890	2300	870	540
46.0	2430	2090	800	450	46.0	2630	2130	790	470
48.8	2240	1850	680	380	48.8	2320	1930	710	370
52.5	2030	1480	500	290	52.5	2070	1710	590	280
58.0	-	-	-	-	58.0	1720	1380	420	170
63.8	-	-	-	-	63.8	1330	1020	230	60

MAIN BOOM ANGLE (deg)	JIB STRUCTURAL CAPACITIES (lb)					
	4TH RETRACTED			4TH EXTENDED		
	0°	15°	30°	0°	15°	30°
69	6000	3900	2800	5180	3900	2800
65	5000	3500	2550	4970	3500	2550
60	4300	3150	2350	4300	3150	2350
55	3800	2850	2200	3800	2850	2200
50	3400	2600	2100	3400	2600	2100
45	3050	2400	2000	3050	2400	2000
40	2800	2250	1950	2800	2250	1950
35	2600	2150	1900	2600	2150	1900
30	2400	2080	1850	2400	2080	1850
25	2300	2050	-	2300	2050	-
20	2200	2000	-	2200	2000	-
15	2100	1950	-	2100	1950	-
10	2050	-	-	2050	-	-
5	2020	-	-	2020	-	-
0	2000	-	-	2000	-	-

**NOTES:**

JIB CAPACITY IS LIMITED BY BOTH STRUCTURAL CAPACITY CHART AND MAIN CAPACITY CHART.

SHADED AREAS ARE GOVERNED BY STRUCTURAL STRENGTH, DO NOT RELY ON TIPPING.

OPERATION OF THIS EQUIPMENT IN EXCESS OF RATING CHARTS AND DISREGARD OF INSTRUCTIONS IS DANGEROUS AND VOIDS WARRANTY.

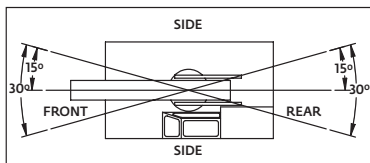

REDUCTION CHART		
	FROM MAIN BOOM RATINGS	FROM JIB RATINGS
MAIN BLOCK	210 lb	N/A
HOOK & BALL	100 lb	100 lb
JIB, STOWED	0 lb	N/A
JIB, DEPLOYED	700 lb	0 lb

RIGGING CHART	
1-PART 0 - 7500 lb	4-PART 0 - 30,000 lb
WIRE ROPE: 1/2 inch diameter Min. breaking strength 26,250 lb	

- The rated loads are the maximum lifting capacities as determined by operating radius only. Any combination of boom lengths and angles may be used to obtain operating radius. The operating radius is the horizontal distance from a projection of the axis of rotation to the supporting surface, before loading, to the center of vertical hoist line or tackle with load applied.
- The rated loads shown on outriggers do not exceed 85% of actual tipping. The rated loads shown on rubber do not exceed 75% of actual tipping. These ratings are based on freely suspended loads with the crane leveled, standing on a firm, uniform supporting surface. Practical working loads depend on supporting surface, operating radius and other factors affecting stability. Hazardous surroundings, climatic conditions, experience of operator and proper training must be taken into account by the operator.
- The weights of all load handling devices, such as hooks, hook blocks, slings, etc., except the hoist rope, shall be considered as part of the load. See reduction chart.
- Ratings on outriggers are with outriggers fully extended.
- Ratings on rubber depend on tire capacity, condition of tires and proper inflation pressure (120 psi). Loads on rubber may be transported at a maximum speed of 2.5 mph on a smooth, hard, level surface with the boom retracted to the shortest length possible and centered over the front.
- For operating radius not shown, use load rating of next larger radius.
- The maximum combined total boom and deck load is 16,000 lb. The maximum deck load only is 20,000 lb.
- Do not induce any external side loads to boom or jib.

1302395

THIS CHART IS ONLY A GUIDE AND SHOULD NOT BE USED TO OPERATE THE CRANE.

The individual crane's load chart, operating instructions and other instructional plates must be read and understood prior to operating the crane.

# Symbols glossary



Axles



Counterweight



Grade



Outriggers



Boom



Drive



Heavy duty jib



Radius



Boom elevation



Electrical system



Hoist



Rotation



Boom extension



Engine



Hookblock



Speed



Boom length



Extension



Hydraulic system



Steering



Boom nose



Frame



Lights



Suspension



Brakes



Fuel tank capacity



Oil



Swing



Cab



Gear



Outrigger controls



Tires



Transmission



# Notes





## Manitowoc Cranes

### Regional headquarters

#### Americas

**Manitowoc, Wisconsin, USA**

Tel: +1 920 684 6621

Fax: +1 920 683 6277

**Shady Grove, Pennsylvania, USA**

Tel: +1 717 597 8121

Fax: +1 717 597 4062

#### Europe, Middle East, Africa

**Ecully, France**

Tel: +33 (0)4 72 18 20 20

Fax: +33 (0)4 72 18 20 00

#### China

**Shanghai, China**

Tel: +86 21 6457 0066

Fax: +86 21 6457 4955

#### Greater Asia-Pacific

**Singapore**

Tel: +65 6264 1188

Fax: +65 6862 4040

### Regional offices

#### Americas

**Brazil**

Alphaville

**Mexico**

Monterrey

**Chile**

Santiago

#### Europe, Middle East,

**Africa**

**Czech Republic**

Netvorice

**France**

Baudemont

Cergy

Decines

**Germany**

Langenfeld

**Hungary**

Budapest

**Italy**

Lainate

**Netherlands**

Breda

**Poland**

Warsaw

**Portugal**

Baltar

**Russia**

Moscow

**South Africa**

Johannesburg

**U.A.E.**

Dubai

**U.K.**

Buckingham

#### China

Beijing

Chengdu

Guangzhou

Xian

#### Greater Asia-Pacific

**Australia**

Brisbane

Melbourne

Sydney

**India**

Chennai

Delhi

Hyderabad

Pune

**Korea**

Seoul

**Philippines**

Makati City

**Singapore**

### Factories

**Brazil**

Passo Fundo

**China**

TaiAn

Zhangjiagang

**France**

Charlieu

Moulins

**Germany**

Wilhelmshaven

**India**

Pune

**Italy**

Niella Tanaro

**Portugal**

Baltar

Fânzeres

**Slovakia**

Saris

**USA**

Manitowoc

Port Washington

Shady Grove

This document is non-contractual. Constant improvement and engineering progress make it necessary that we reserve the right to make specification, equipment, and price changes without notice. Illustrations shown may include optional equipment and accessories and may not include all standard equipment.