



KRUPP

**150 ton Capacity
All-Terrain - Crane**



KMK 5150

Hook elevation diagram

Main boom and lattice extension



44 - 166 ft



33/52 ft



360°

Counterweight **46,3*** lbs

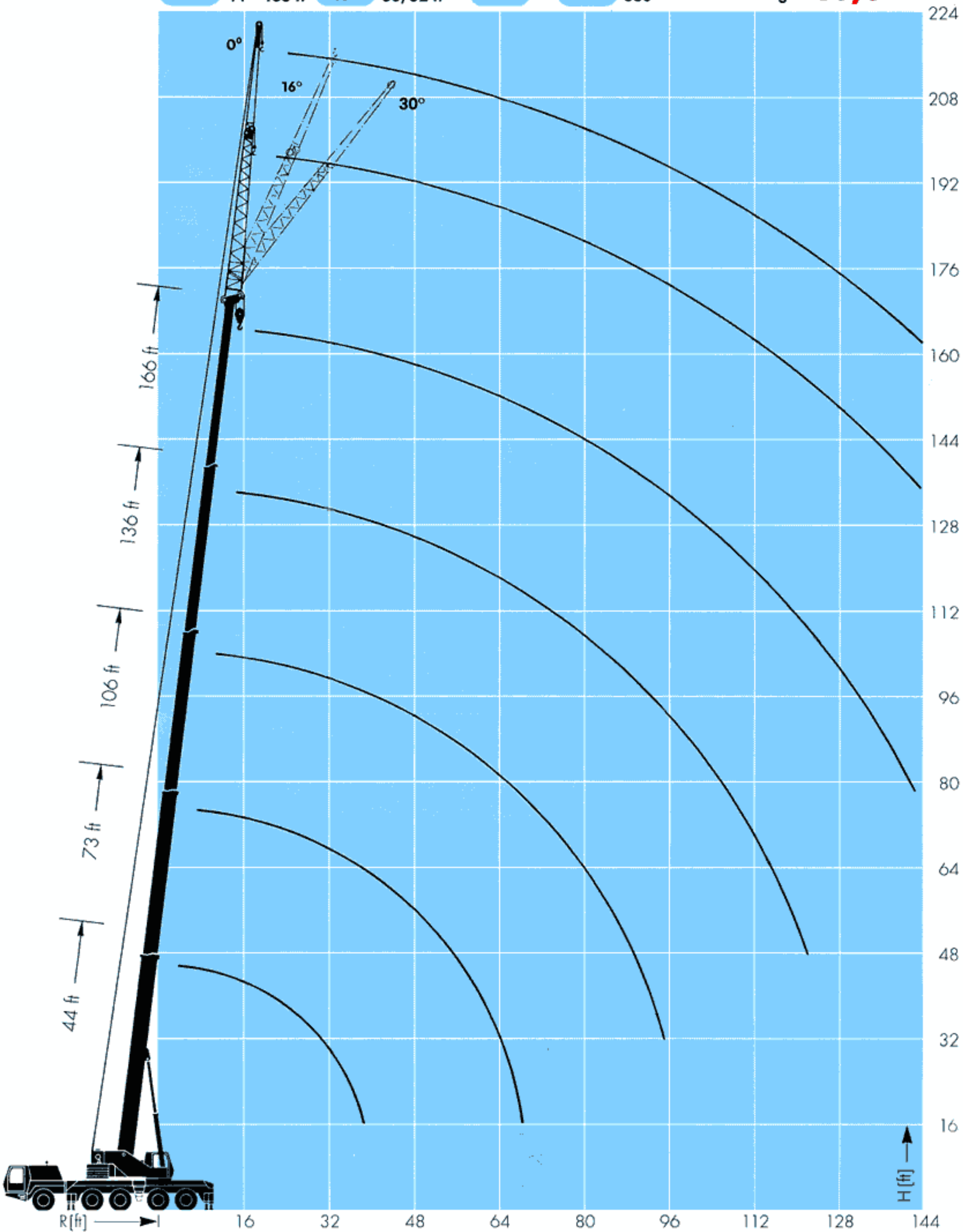

* 1000 lbs

Main Boom

Lifting Capacities in 1000 lbs



44 – 166 ft



360°

Counterweight **46,3*** lbs

Radius ft	Boom-length													Radius ft	
	44 ft ¹⁾	44 ft	74 ft	74 ft	88 ft	104 ft	105 ft	106 ft	119 ft	135 ft	136 ft	150 ft	166 ft		
8	*300,0														8
10	*261,0	218,0	133,0	87,0											10
15	*169,0	160,0	133,0	87,0	102,0										15
20	121,0	121,0	116,0	87,0	102,0	82,0	68,0	38,8	65,0						20
25	93,0	93,0	88,0	87,0	89,0	82,0	67,0	38,8	65,0	51,0	38,8	38,8			25
30	74,0	74,0	70,0	76,0	70,0	72,0	58,0	38,8	63,0	51,0	38,8	38,8	31,6		30
35			57,0	62,0	57,0	59,0	52,0	37,2	56,0	50,0	38,8	38,8	31,6		35
40			47,0	52,0	47,0	49,0	46,0	33,0	49,0	45,0	37,2	38,8	31,6		40
45			39,0	45,0	39,6	41,2	41,0	29,8	41,2	40,0	34,2	38,2	31,6		45
50			33,0	38,4	33,4	35,0	37,2	27,0	35,2	35,8	31,0	34,4	31,6		50
55			28,0	33,4	28,4	30,0	33,8	24,8	30,0	31,2	28,2	31,0	30,0		55
60					23,4	25,6	29,8	22,6	25,6	27,0	25,8	27,8	27,0		60
65					19,0	21,2	26,0	20,8	21,2	22,6	23,8	24,6	24,6		65
70					15,2	17,4	22,4	19,4	17,4	18,8	22,2	20,8	22,4		70
75						14,2	19,0	18,0	14,2	15,6	20,6	17,6	19,0		75
80						11,6	16,4	17,0	11,6	13,0	19,0	14,8	16,4		80
85						9,2	14,0	16,0	9,2	10,6	17,2	12,4	14,0		85
90						7,2	11,8	15,4	7,2	8,6	15,2	10,4	11,8		90
95									5,6	6,8	13,2	8,6	10,0		95
100									4,0	5,2	11,6	7,0	8,4		100
105									2,6	3,8	10,2	5,6	7,0		105
110										2,6	8,8	4,2	5,6		110
115											7,6	3,0	4,4		115
120												2,0	3,4		120
125													2,4		125
	T1	0	0	100	0	100	100	0	0	100	100	0	100	100	T1
	T2	0	0	0	50	50	50	100	0	100	100	100	100	100	T2
%	T3	0	0	0	50	0	50	100	100	50	100	100	100	100	T3
	T4	0	0	0	0	0	0	0	100	0	0	100	50	100	T4

over rear
 1) outrigger base 28' 2" x 17' 10"
 * with special equipment

* 1000 lbs



44 – 166 ft



360°

Counterweight **27,8*** lbs

Radius ft	Boom-length													Radius ft	
	44 ft	74 ft	74 ft	88 ft	104 ft	105 ft	106 ft	119 ft	135 ft	136 ft	150 ft	166 ft			
10	218,0	133,0	87,0												10
15	158,0	133,0	87,0	102,0											15
20	112,0	107,0	87,0	102,0	82,0	68,0	38,8	65,0							20
25	86,0	82,0	87,0	82,0	82,0	67,0	38,8	65,0	51,0	38,8	38,8				25
30	68,0	64,0	70,0	65,0	66,0	58,0	38,8	63,0	51,0	38,8	38,8	31,6			30
35		52,0	58,0	52,0	54,0	52,0	37,2	54,0	50,0	38,8	38,8	31,6			35
40		42,4	48,0	43,0	45,0	46,0	33,0	44,0	45,0	37,2	38,8	31,6			40
45		32,8	41,0	33,6	36,2	41,0	29,8	35,6	36,0	34,2	37,2	31,6			45
50		25,0	33,0	25,8	28,2	34,0	27,0	28,4	29,2	31,0	30,6	31,6			50
55		19,2	26,8	19,8	22,2	27,6	24,8	22,4	23,8	28,2	25,4	26,4			55
60				15,2	17,6	22,8	22,6	17,6	19,2	25,8	21,2	22,2			60
65				11,6	13,8	18,8	20,8	13,8	15,2	22,4	17,2	18,8			65
70				8,4	10,6	15,6	19,4	10,8	12,0	19,2	14,0	15,6			70
75					8,0	12,8	18,0	8,0	9,4	16,4	11,4	12,8			75
80					5,8	10,6	16,0	5,8	7,2	14,0	9,0	10,6			80
85					3,8	8,6	14,0	4,0	5,2	12,0	7,0	8,6			85
90					2,2	6,8	12,2	2,2	3,6	10,2	5,4	6,8			90
95									2,0	8,6	3,8	5,4			95
100										7,2	2,6	4,0			100
105										6,0		2,8			105
110										4,8					110
115										3,8					115
	T1	0	100	0	100	100	0	0	100	100	0	100	100	100	T1
	T2	0	0	50	50	50	100	0	100	100	100	100	100	100	T2
%	T3	0	0	50	0	50	100	100	50	100	100	100	100	100	T3
	T4	0	0	0	0	0	0	100	0	0	100	50	100	100	T4

* 1000 lbs



Main Boom

Lifting Capacities in 1000 lbs



44 – 166 ft



360°

Counterweight **9,3*** t

Radius		Boom-length												Radius	
ft		44 ft	74 ft	74 ft	88 ft	104 ft	105 ft	106 ft	119 ft	135 ft	136 ft	150 ft	166 ft	ft	
10		218,0	133,0	87,0											10
15		146,0	133,0	87,0	102,0										15
20		104,0	99,0	87,0	100,0	82,0	68,0	38,8	65,0						20
25		79,0	75,0	81,0	75,0	77,0	67,0	38,8	65,0	51,0	38,8	38,8			25
30		63,0	58,0	64,0	56,0	56,0	58,0	38,8	53,0	51,0	38,8	38,8	31,6		30
35			41,4	51,0	40,4	41,4	49,0	37,2	39,6	39,8	38,8	38,8	31,6		35
40			29,0	38,0	29,8	31,2	38,2	33,0	29,8	30,4	37,2	31,8	31,6		40
45			20,6	29,0	21,4	23,8	30,0	29,8	22,8	23,6	32,8	25,0	26,2		45
50			14,6	22,6	15,4	17,8	23,4	27,0	17,4	18,2	27,2	19,8	21,0		50
55			10,0	17,6	10,6	13,0	18,4	24,6	13,0	14,0	22,4	15,6	17,0		55
60					7,0	9,4	14,6	20,6	9,4	10,6	18,4	12,2	13,6		60
65					4,2	6,4	11,4	17,2	6,4	7,6	15,0	9,4	10,8		65
70						3,8	8,8	14,6	4,0	5,2	12,4	7,0	8,4		70
75							6,6	12,2	1,8	3,2	10,2	5,0	6,4		75
80							4,8	10,4			8,2	3,2	4,6		80
85							3,2	8,6			6,6		3,0		85
90								7,2			5,2				90
95											4,0				95
100											2,8				100
%	T1	0	100	0	100	100	0	0	100	100	0	100	100	T1	
	T2	0	0	50	50	50	100	0	100	100	100	100	100	T2	
	T3	0	0	50	0	50	100	100	50	100	100	100	100	T3	
	T4	0	0	0	0	0	0	100	0	0	100	50	100	T4	

* 1000 lbs

Main Boom + swing-away extension

Lifting Capacities in 1000 lbs



33/52 ft



360°

Counterweight **46,3*** lbs

Radius ft	Main boom length 166 ft						Radius ft
	Lattice extension length 33 ft			Lattice extension length 52 ft			
	0°	16°	30°	0°	16°	30°	
30	17,0			10,2			30
35	17,0			10,2			35
40	17,0	16,4		10,2			40
45	17,0	16,4	14,6	10,2			45
50	17,0	16,4	14,2	10,2	9,8		50
55	17,0	16,0	14,0	10,2	9,4		55
60	17,0	15,8	13,8	10,2	9,2	7,8	60
65	17,0	15,4	13,6	10,2	9,0	7,6	65
70	17,0	15,2	13,4	10,2	8,8	7,4	70
75	17,0	14,8	13,0	10,2	8,6	7,2	75
80	16,6	14,6	12,8	10,2	8,4	7,2	80
85	15,4	14,0	12,6	10,0	8,2	7,0	85
90	13,8	13,2	12,4	9,8	8,0	6,8	90
95	11,8	12,4	12,4	9,4	7,8	6,8	95
100	10,2	11,2	12,0	9,2	7,6	6,6	100
105	8,8	9,6	10,4	9,0	7,4	6,6	105
110	7,4	8,2	8,8	8,6	7,2	6,4	110
115	6,2	7,0	7,6	7,6	7,2	6,4	115
120	5,2	5,8	6,4	6,6	7,0	6,4	120
125	4,2	4,8	5,2	5,6	6,8	6,2	125
130	3,2	3,8	4,2	4,6	5,8	6,2	130
135	2,4	3,0	3,4	3,8	4,8	5,6	135
140		2,2	2,6	3,0	4,0	4,6	140
145				2,2	3,2	3,8	145
150					2,6	3,0	150
155						2,4	155
T1	100	100	100	100	100	100	T1
T2	100	100	100	100	100	100	T2
T3	100	100	100	100	100	100	T3
T4	100	100	100	100	100	100	T4

* 1000 lbs

Counterweight **27,8** lbs

Radius ft	Main boom length 166 ft						Radius ft
	Lattice extension length 33 ft			Lattice extension length 52 ft			
	0°	16°	30°	0°	16°	30°	
30	17,0			10,2			30
35	17,0			10,2			35
40	17,0	16,4		10,2			40
45	17,0	16,4	14,6	10,2			45
50	17,0	16,4	14,2	10,2	9,8		50
55	17,0	16,0	14,0	10,2	9,4		55
60	17,0	15,8	13,8	10,2	9,2	7,8	60
65	17,0	15,4	13,6	10,2	9,0	7,6	65
70	17,0	15,2	13,4	10,2	8,8	7,4	70
75	14,6	14,8	13,0	10,2	8,6	7,2	75
80	12,4	14,0	12,8	10,2	8,4	7,2	80
85	10,6	11,8	12,6	10,0	8,2	7,0	85
90	8,8	10,0	10,8	9,8	8,0	6,8	90
95	7,2	8,2	9,0	8,6	7,8	6,8	95
100	5,8	6,8	7,6	7,2	7,6	6,6	100
105	4,6	5,4	6,2	6,0	7,4	6,6	105
110	3,4	4,4	5,0	4,8	6,4	6,4	110
115	2,4	3,2	3,8	3,8	5,2	6,4	115
120		2,2	2,8	3,0	4,2	5,2	120
125				2,0	3,4	4,2	125
130					2,4	3,4	130
135						2,4	135
T1	100	100	100	100	100	100	T1
T2	100	100	100	100	100	100	T2
T3	100	100	100	100	100	100	T3
T4	100	100	100	100	100	100	T4

* 1000 lbs



Main Boom + swing-away extension

Lifting Capacities in 1000 lbs



33/52 ft



360°

Counterweight **9,3*** lbs

Radius ft	Main boom length 166 ft						Radius ft		
	Lattice extension length 33 ft			Lattice extension length 52 ft					
	0°	16°	30°	0°	16°	30°			
30	17,0			10,2			30		
35	17,0			10,2			35		
40	17,0	16,4		10,2			40		
45	17,0	16,4	14,6	10,2			45		
50	17,0	16,4	14,2	10,2	9,8		50		
55	17,0	16,0	14,0	10,2	9,4		55		
60	15,0	15,8	13,8	10,2	9,2	7,8	60		
65	12,4	14,2	13,6	10,2	9,0	7,6	65		
70	10,0	11,8	13,0	10,2	8,8	7,4	70		
75	8,0	9,6	10,8	9,2	8,6	7,2	75		
80	6,2	7,6	8,8	7,6	8,4	7,2	80		
85	4,6	6,0	7,0	6,0	8,2	7,0	85		
90	3,2	4,6	5,4	4,6	6,8	6,8	90		
95	2,0	3,2	4,0	3,4	5,4	6,8	95		
100		2,0	2,8	2,4	4,2	5,6	100		
105					3,2	4,4	105		
110					2,2	3,4	110		
115						2,2	115		
 %	T1	100	100	100	100	100	100	T1	 %
	T2	100	100	100	100	100	100	T2	
	T3	100	100	100	100	100	100	T3	
	T4	100	100	100	100	100	100	T4	

* 1000 lbs

Notes for lifting capacities

Rated loads do not exceed 85% of tipping load with the machine properly levelled on firm ground.

360° duties – on outriggers fully extended.

Note counterweight required as listed in relevant lifting capacity columns.

For safe crane operation due allowance must be made to compensate for high winds, side load, pendulum action and other hazardous conditions. No side pull permitted.

Hook blocks, sling and/or boom attachments are considered part of load, and their weight must be deducted from the rated lifting capacity to determine the net load.

Boom must be extended in accordance with sequence as noted on lifting capacity chart.

Consult crane manual to determine weight reduction for load handling devices and boom attachments.

Operate crane strictly in compliance with operator's manual.

NOTES

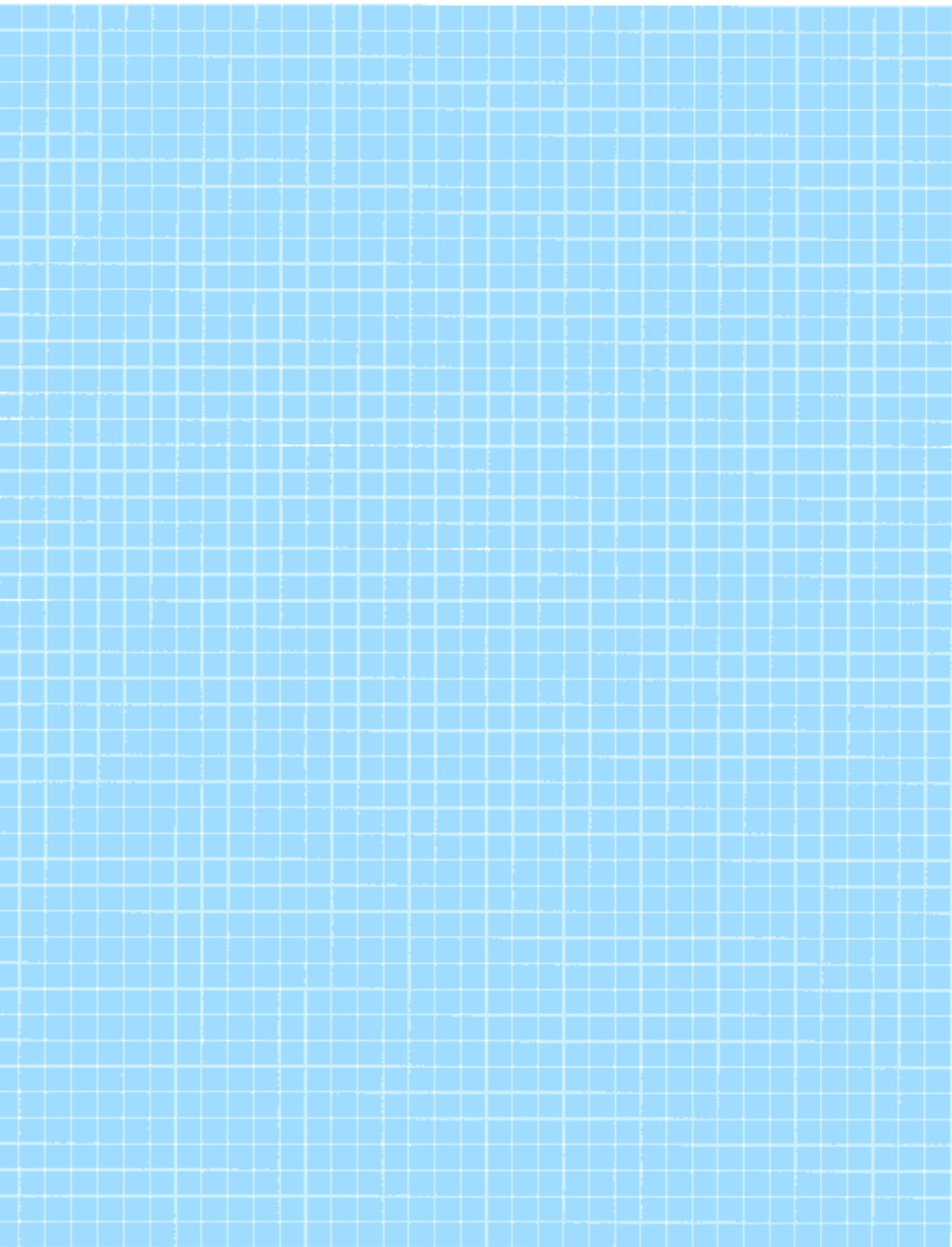

Weights/Working speeds



Axle	1	2	3	4	5	Total weight
1000 lbs	26,5	26,5	26,5	26,5	26,5	132,5

incl. 9.300 lbs counterweight, tires 16.00 R 25



Lifting capacity tons	Sheaves	Parts of line	Weight lbs
90	7	4 - 13	2430
50	3	1 - 7	1430
20	1	1 - 3	7660



Gear	1	2	3	4	5	R	Gradeability max.
On-Road (mph)	8,0	13,0	21,0	31,0	43,0	9,0	
Off-Road (mph)	4,6	7,3	11,4	16,8	23,1	4,9	52 %
Tyres	14.00 R 25						



Drives	ininitely variable	Rope diameter/Rope length	Max. single line pull
Main hoist	0 - 390 ft/min single line	19 mm (3/4") 780 ft	13700 lbs
Auxiliary hoist	0 - 390 ft/min single line	19 mm (3/4") 590 ft	13700 lbs
Swing	0 - 1,8 min ⁻¹		
Boom lift	approx. 65 seconds to reach - 3° to + 84°		
Telescoping	approx. 220 seconds for boom length from 44 - 166 ft		



Telescopic boom



On outriggers



Working range



Axle load



Hook blocks and hook



Crane movements



Speed



Swing-away lattice

Dimensions

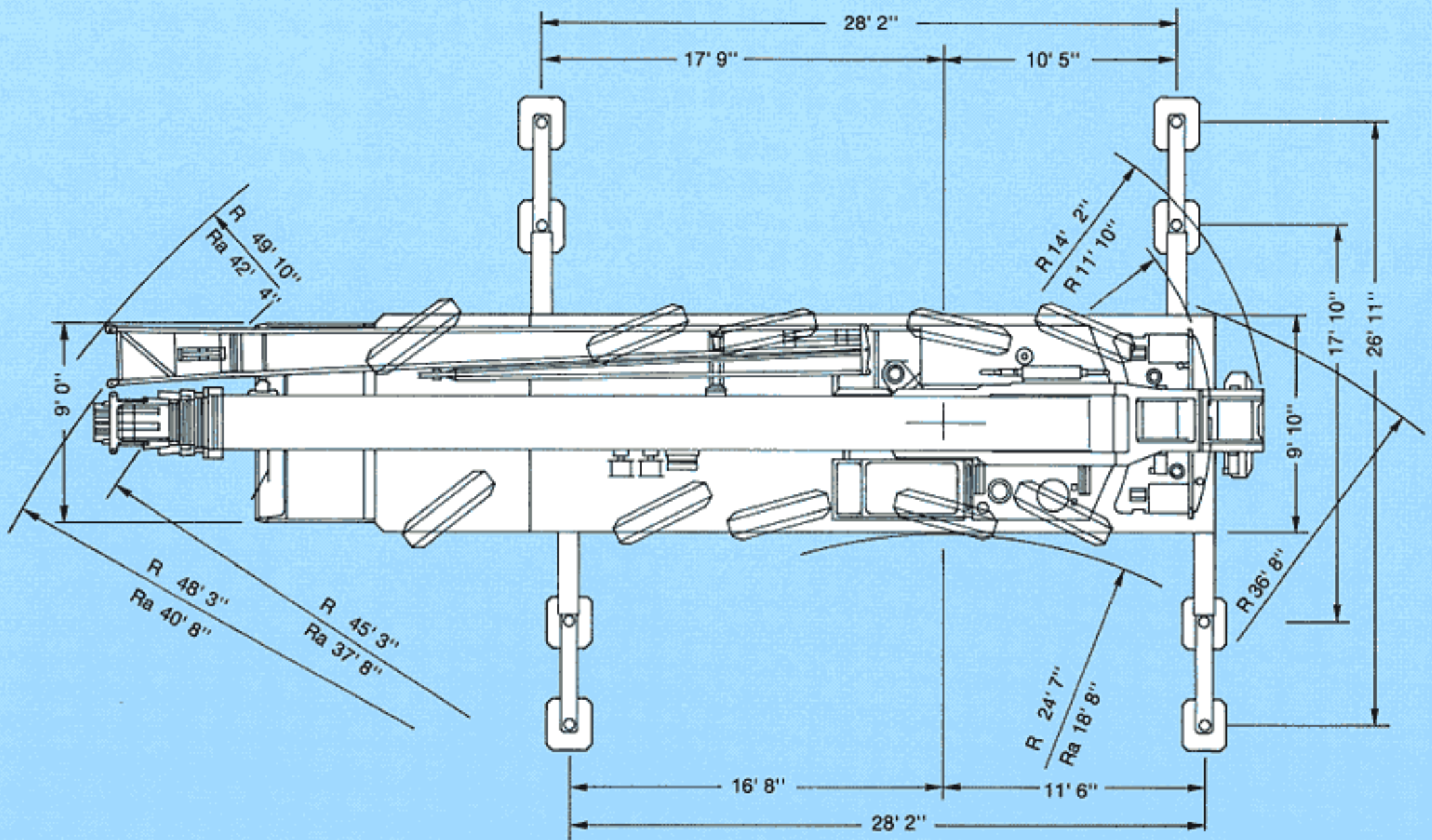
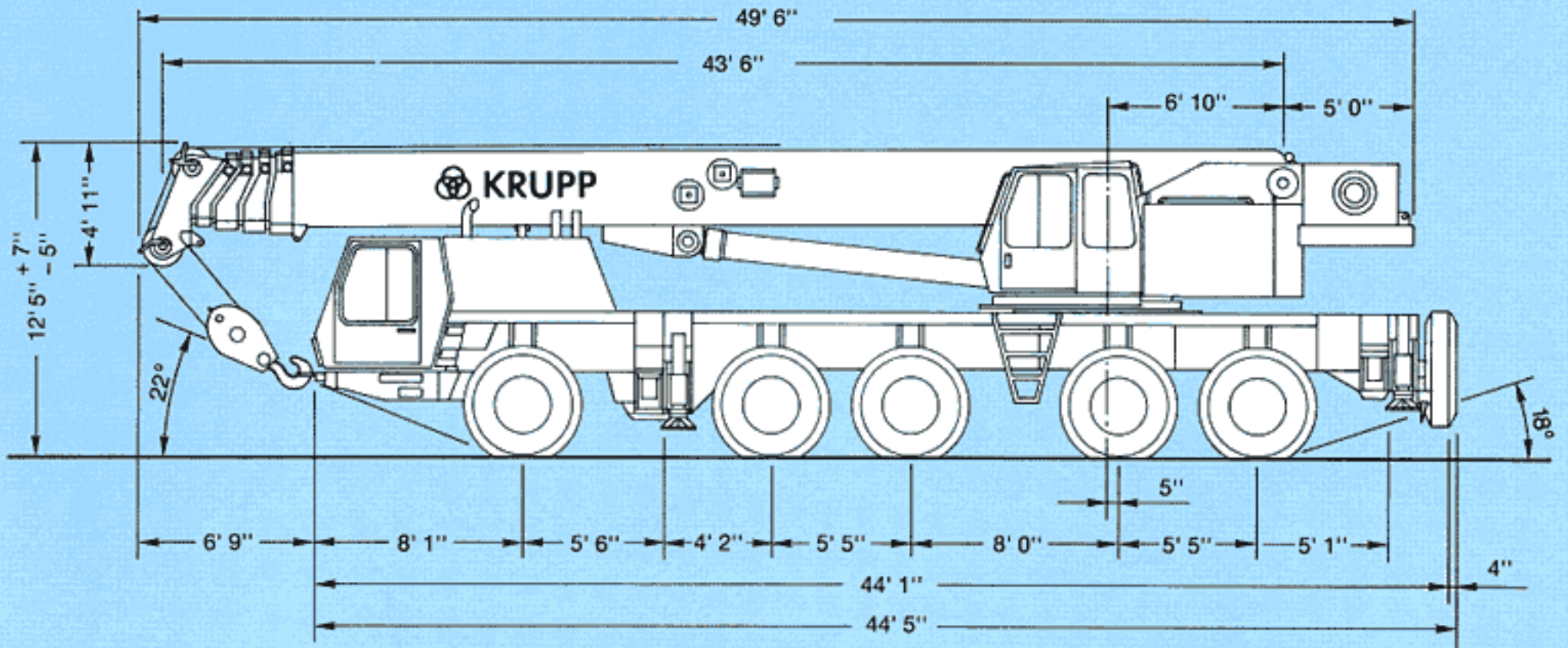

Carrier

Chassis:	Special KRUPP 5-axle carrier, all-welded torsion-resistant box-type construction made of close grain steel.
Outriggers:	4 – 2 stage hydraulically telescoping beams with vertical cylinders and outrigger pads. Independent horizontal and vertical movement control on each side of the chassis.
Engine:	Mercedes Benz OM 442 LA, Diesel, 8 cylinders, water-cooled, with turbocharger and supercharger intercooler, 370 kW (503 HP) at 2100 min ⁻¹ . (EG 80/1269 fan loose). Max. torque: 2020 Nm at 1100 – 1600 min ⁻¹ . Tank capacity: 100 gal.
Transmission:	Allison automatic CLBT 755.
Transfer case:	Transfer case with 2 speeds and longitudinal differential lock.
Axle lines:	5 axle lines: 2, 3, and 5 are driven axle lines; 1, 2, 3 and 5 are steering axle lines; the 4th axle line is rigid.
Suspension:	All axle lines with lockable hydropneumatic suspension and hydraulic axle lock-out. Suspension level control. Range: + 6½" / - 5½".
Tires:	10 tires 14.00 R 25.
Steering:	Dual-circuit, stand-by steering pump.
Brakes:	Service brake: pneumatic dual-circuit, acting on all wheels, air dryer. Permanent brake: hydraulic retarder, integrated within Allison automatic powershift. Hand brake: pneumatically operated spring-loaded brake acting on 2nd, 3rd, 4th and 5th axle line.
Driver's cab:	Aluminum , 2-man-design, safety glass, driver's seat with hydraulic suspension, engine hot-water heater. Complete instrumentation and driving controls.
Electrical system:	Three-phase generator 28 V/55 A, 2 batteries 12 V/170 Ah, lighting system and signals 24 V.

Superstructure

Frame:	Torsion-resistant welded construction in high strength steel.
Engine:	Mercedes-Benz OM 366 A, Diesel, 6 cylinders, water-cooled, 104 kW (141 HP) at 1800 min ⁻¹ . (EG 80/1269 fan rigid). Max. torque: 566 Nm at 1500 – 1600 min ⁻¹ . Tank capacity: 50 gal.
Hydraulic system:	3 separate circuits. Tank capacity: 330 gal hydraulic oil.
Control system:	Infinite variation of all crane movements by control levers with automatic reset to zero.
Main hoist:	Rope drum with special grooving and integrated planetary gear with multiple-disk brake and axial piston motor.
Derricking	1 cylinder. Boom angle from -1,5° to +85°.
Slewing:	Vane motor, planetary gear, service brake and holding brake.
Cab:	Aluminium , full vision, safety glass, adjustable operator's seat with hydraulic suspension, motor-dependent hot-water heater. Armrest-integrated crane controls. Ergonomically arranged instrumentation and crane operating.
Safety installations:	Hoist and lowering limit switch, pipe beak safety valves, pressure relief valves.
Telescopic boom:	Welded construction in high strength steel, 1 pivot basic section, 4 telescopic sections. Total boom length 166 ft, hydraulic extension.
Electrical system:	Three-phase generator 28 V/55 A, 2 batteries 12 V/143 Ah.

Additional equipment

Drive/Steering:	10 × 8 × 8
Steer:	All-wheel steer.
Tires:	10 tires, 16.00 R 25/20,5 R 25
Swing-away lattice:	2-stage, stowing alongside boom, 33 – 52 ft + 26 ft insert.
Aux. hoist:	2nd hoisting gear.
Driver's cab/cab:	Engine-independent heater usable as engine preheater.
Safe load indicator:	Electronic load moment safety device with automatic cut-out and digital display for actual and admissible load, radius and various working conditions.

Subject to technical modification

KRUPP Hydraulic Mobile Cranes

Product Range

All-Terrain Cranes		Max. lifting capacity	Max. hook height
KMK 2020		20 ton	92 ft
KMK 2025		25 ton	125 ft
KMK 3050		50 ton	177 ft
KMK 4085		85 ton	185 ft
KMK 4100		100 ton	190 ft
KMK 5110		110 ton	215 ft
KMK 5150		150 ton	245 ft
KMK 5175		175 ton	269 ft
KMK 6190		190 ton	361 ft
KMK 6275		275 ton	364 ft
KMK 7300		300 ton	336 ft



KRUPP CRANES NORTH AMERICA

210 VANDALE DR. HOUSTON (PITTSBURGH), PA. 15342 PHONE 412-746-9360 · FAX 412-746-9350

PITTSBURGH, PA · HOUSTON, TX · ATLANTA, GA · SEATTLE, WA · TORONTO, ONTARIO

Subject to technical modifications without notice



KRUPP