

Manitowoc MLC165-1

Service/Maintenance Manual



Grove

Manitowoc

National Crane

Potain





SERVICE/MAINTENANCE MANUAL

This manual has been prepared for and is considered part of -

MLC165-1

Crane Model Number

XXXXXRef

Crane Serial Number

This manual is divided into the following sections:

| | |
|-------------------|--------------------------|
| SECTION 1 | INTRODUCTION |
| SECTION 2 | HYDRAULIC SYSTEM |
| SECTION 3 | ELECTRICAL SYSTEM |
| SECTION 4 | BOOM |
| SECTION 5 | HOISTS |
| SECTION 6 | SWING SYSTEM |
| SECTION 7 | POWER TRAIN |
| SECTION 8 | UNDER CARRIAGE |
| SECTION 9 | LUBRICATION |
| SECTION 10 | ACCESSORIES |

NOTICE

The serial number of the crane and applicable attachments (for example, luffing jib) is the only method your Manitowoc dealer or the Manitowoc Crane Care Lattice Team has of providing you with correct parts and service information.

The serial number is located on a crane identification plate attached to the operator cab and each attachment. Refer to the Nameplate and Decal Assembly drawing in Section 2 of this manual for the exact location of the crane identification plate.

Always furnish serial number of crane and its attachments when ordering parts or discussing service problems with your Manitowoc dealer or the Manitowoc Crane Care Lattice Team.



WARNING

To prevent death or serious injury:

- Avoid unsafe operation and maintenance.
Crane and attachments must be operated and maintained by trained and experienced personnel. Manitowoc is not responsible for qualifying these personnel.
- Do not operate or work on crane or attachments without first reading and understanding instructions contained in Operator Information Manual and Service Manual supplied with crane and applicable attachments.
- Store Operator Information Manual and Service Manual in operator cab.

If Operator Information Manual or Service Manual is missing from cab, contact your Manitowoc dealer for a new one.

THE ORIGINAL LANGUAGE OF THIS PUBLICATION IS ENGLISH

See end of this manual for Alphabetical Index

| | |
|---|--------------------------|
| SECTION 1 | Introduction |
| Continuous Innovation | 1-1 |
| Safety Messages | 1-1 |
| Safety Alert Symbol | 1-1 |
| Signal Words | 1-1 |
| Safe Maintenance Practices | 1-2 |
| Read This Manual | 1-2 |
| Basic Crane Maintenance Safety | 1-2 |
| Environmental Protection | 1-4 |
| Abbreviations | 1-4 |
| Identification and Location of Components | 1-5 |
| SECTION 2 | Hydraulic System |
| Hydraulic System Overview | 2-1 |
| Hydraulic Pump Locations | 2-1 |
| Main Pump | 2-2 |
| Swing Pump | 2-3 |
| Accessory Pump | 2-4 |
| Free Fall Cooling Pump | 2-4 |
| Fan Cooling Pump | 2-5 |
| Drum 1 and 2 Motors | 2-6 |
| Drum 3 and 4 Motors | 2-6 |
| Swing Motor | 2-7 |
| Cooling Fan Motor | 2-7 |
| Travel Motors | 2-8 |
| Main Control Valve Manifold | 2-9 |
| Pilot Brake and Pawl Manifold | 2-10 |
| Accessory Manifold | 2-11 |
| Pilot Signal Manifold | 2-12 |
| Free Fall Manifold | 2-13 |
| Cooler Bypass Manifold | 2-13 |
| Hydraulic System Specifications | 2-15 |
| Hydraulic System Maintenance | 2-16 |
| Safety | 2-16 |
| Storing and Handling Oil | 2-16 |
| Storing and Handling Parts | 2-16 |
| Inspecting the Hydraulic System | 2-17 |
| Inspecting and Replacing Hydraulic Hoses | 2-18 |
| Tightening Hydraulic Connections | 2-19 |
| Replacing Desiccant Breather Cartridge | 2-24 |
| Replacing Return Filters | 2-25 |
| Replacing Pilot Filter | 2-26 |
| Replacing the Swing Filter | 2-27 |
| Changing the Hydraulic Oil | 2-29 |
| Servicing the Pumps | 2-30 |
| Replacing a Pressure Transducer | 2-30 |
| Hydraulic Tests and Calibrations | 2-31 |
| Travel Speed Test | 2-31 |
| Swing Speed Test | 2-32 |
| Pressure Transducer Test | 2-33 |
| Controls Calibration | 2-34 |
| Drum Brake Test | 2-35 |
| Swing Brake Test | 2-35 |
| SECTION 3 | Electrical System |

| | |
|---|------|
| Drum Identification | 3-1 |
| Electrical Power Sequence | 3-1 |
| Engine Bus Power | 3-1 |
| Cab Bus Power | 3-1 |
| CAN Bus Power | 3-1 |
| CAN Bus Control System | 3-1 |
| Master Node (Node 1) | 3-2 |
| Engine Node (Node 0) | 3-3 |
| Side Console Node (Node 2) | 3-3 |
| Universal Nodes (Nodes 3–5) | 3-3 |
| Graphic Nodes | 3-6 |
| Wind Speed Remote Input Node | 3-6 |
| Boom and Luffing Jib Remote Input Nodes | 3-6 |
| Solenoid Valve Identification | 3-7 |
| Circuit Breakers | 3-8 |
| Alternator Circuit | 3-8 |
| Engine Node | 3-8 |
| operator cab | 3-9 |
| Grid Heater | 3-9 |
| Exhaust Aftertreatment System | 3-10 |
| 240 VAC Electric System | 3-10 |
| Checking and Replacing Electrical Components | 3-11 |
| Node Locations | 3-13 |
| Component to Node Identification | 3-13 |
| Pump and Motor Voltages and Currents | 3-14 |
| Abbreviations | 3-14 |
| Checking Electrical Inputs/Outputs (Using the Test Box) | 3-15 |
| Checking Electrical Inputs/Outputs (Using the Test Board) | 3-16 |
| Test Voltages | 3-17 |
| Node Heading Descriptions | 3-17 |
| Node 1 — Master | 3-18 |
| Node 2 — Alarms, Switches, and Gauge Panel | 3-20 |
| Node 3 — Drum Control and Limit Switches | 3-22 |
| Node 4 — Swing Control, Drum Brake and Pawl Control | 3-25 |
| Node 5 — Accessories | 3-27 |
| Boom Remote Input Node 30 | 3-30 |
| Luffing Jib Remote Input Node 31 | 3-31 |
| Node 0 — Engine | 3-32 |

SECTION 4 **Boom**

| | |
|--|------|
| Automatic Boom Stop | 4-1 |
| Automatic Boom Stop Maintenance | 4-1 |
| Automatic Boom Stop Adjustment | 4-3 |
| Automatic Boom Stop Actuator Rod Replacement | 4-3 |
| Physical Boom Stop | 4-5 |
| Physical Boom Stop Angles | 4-5 |
| Physical Boom Stop Operation | 4-5 |
| Physical Boom Stop Adjustment | 4-5 |
| Boom and Luffing Jib Angle Indicator | 4-6 |
| Mast Angle Sending Unit | 4-7 |
| Adjusting Mast Angle | 4-7 |
| Strap Inspection and Maintenance | 4-8 |
| Inspection | 4-8 |
| Identifying Straps | 4-8 |
| Replacement Specifications | 4-9 |
| Storing Straps | 4-11 |

| | |
|---|------|
| Removing Straps from Service | 4-12 |
| Inspection Checklist | 4-12 |
| Lattice Section Inspection and Lacing Replacement | 4-15 |

SECTION 5 **Hoists**

| | |
|--|------|
| Hoist Theory of Operation | 5-1 |
| Overview of the Hoist System | 5-1 |
| Working and Pilot Flow Components | 5-4 |
| Free Fall System (Optional) | 5-8 |
| Electrical Diagrams | 5-11 |
| Drum Gearboxes | 5-19 |
| Gear Oil Specifications | 5-19 |
| Oil Analysis | 5-19 |
| Periodic Maintenance | 5-19 |
| Quick-Drain Valve | 5-19 |
| Oil Change Procedure | 5-19 |
| Drum 1 Pawl | 5-29 |
| Operation | 5-29 |
| Maintenance | 5-29 |
| Drum 4 Pawl | 5-31 |
| Operation | 5-31 |
| Maintenance | 5-31 |
| Drum 3 Pawl | 5-32 |
| Operation | 5-32 |
| Maintenance | 5-32 |
| Adjustment | 5-32 |
| Speed Sensor—Hoist Motors | 5-33 |
| Replacement | 5-33 |
| Speed Sensor—Free Fall Drums | 5-35 |
| Maintenance | 5-35 |
| Minimum Bail Limit (Drum 3) | 5-37 |
| Limit Switch Replacement | 5-37 |
| Weekly Maintenance | 5-37 |
| Pressure Roller (Drum 3) | 5-39 |
| Minimum Bail Limits and Pressure Rollers (Drums 1 and 2) | 5-40 |
| Minimum Bail Limit (Drum 1 and 2) | 5-43 |
| Limit Switch Replacement | 5-43 |
| Weekly Maintenance | 5-43 |
| Pressure Roller (Drum 1 and 2) | 5-45 |
| Pressure Roller (Drum 2) | 5-45 |
| Pressure Roller (Drum 1) | 5-45 |
| Block-Up Limit Switch | 5-46 |
| Theory of Operation | 5-47 |
| Weekly Maintenance | 5-47 |
| Adjustment | 5-49 |
| Free Fall Brake | 5-51 |
| Removing Free Fall Brake Cover | 5-51 |
| Installing Free Fall Brake Cover | 5-51 |
| Wire Rope Inspection and Replacement | 5-52 |
| Maintain a Wire Rope Condition Report | 5-52 |
| Daily Inspection | 5-53 |
| Periodic Comprehensive Inspection | 5-54 |
| Replacement Criteria | 5-54 |
| Distributing Wire Rope Wear | 5-56 |
| Sheave, Roller, and Drum Inspection (Weekly) | 5-57 |
| Load Block and Hook-and-Weight Ball Inspection | 5-60 |

SECTION 6 Swing System

Swing System Overview 6-1
 Swing Brake 6-2
 Swing Handle Command 6-3
 Swing Pump Control 6-3
 Swinging Left 6-3
 Swinging Right 6-3
 Coasting 6-3
 Swing System Pressure Feedback 6-3
 Swing Alarms 6-3
 Manual Release of Swing Brake 6-5
 Swing Gearbox 6-6
 Gear Oil Specifications 6-6
 Oil Analysis 6-6
 Periodic Maintenance 6-6
 Quick-Drain Valve 6-7
 Oil Change Procedure 6-7

SECTION 7 Power Train

Batteries 7-1
 Safety 7-1
 Causes of Battery Failure 7-1
 Maintenance 7-2
 Charging 7-3
 Storage 7-4
 Battery Disconnect Switch 7-4
 Battery Charger 7-4
 Engine Controls 7-4
 Air Cleaner 7-6
 Inspection 7-6
 Changing the Filters 7-6
 Engine Throttle Adjustment 7-8
 Hand Throttle Control 7-8
 Foot Throttle Control 7-8
 Engine Enclosure 7-10
 Engine Belt Routing 7-10
 Engine Radiator 7-11
 Checking Coolant Level 7-11
 Draining and Filling Cooling System 7-12
 Exhaust Aftertreatment System 7-15
 DEF Tank 7-15
 Coolant Solenoid Valve 7-16
 Coolant Manifold 7-16
 Air Bleed Valves 7-16
 DEF Supply Module 7-16
 SCR Module 7-16
 DRT Module 7-16
 DEF Dosing Module 7-17
 DOC Module 7-17
 DEF Heating and Cooling System 7-17

SECTION 8 Under Carriage

Travel Overview 8-1
 Travel Enable 8-1
 No Travel 8-1
 Forward Travel 8-1

Reverse Travel 8-1
 Travel Speed Selection 8-1
 Turntable Bearing Maintenance 8-5
 Installation 8-5
 Torque Requirements 8-5
 Crawler Preventative Maintenance 8-7
 Crawler Tread Slack Measurement 8-7
 Crawler Tread Slack Adjustment 8-7
 Crawler Hand Pump and Jacking Cylinder 8-8
 Assembly 8-8
 Maintenance 8-8
 Air Removal 8-9
 Operation 8-9

SECTION 9. Lubrication

Lubrication 9-1
 Lube and Coolant Product Guide 9-1

SECTION 10. Accessories

Accessory System Pressure 10-1
 Carbody Theory of Operation 10-1
 Jack Cylinders 10-2
 Pin Pullers 10-2
 Rotating Bed Cylinders 10-3
 Mast 10-5
 Assembly Cylinder (Optional) 10-6
 Boom Butt Pin Pullers 10-7
 Counterweight Cylinders 10-7
 Counterweight Pin Pullers 10-8
 Cab Tilt 10-9

THIS PAGE INTENTIONALLY LEFT BLANK

Reference Only

SECTION 1 INTRODUCTION

TABLE OF CONTENTS

| | |
|--|-----|
| Continuous Innovation | 1-1 |
| Safety Messages | 1-1 |
| Safety Alert Symbol | 1-1 |
| Signal Words | 1-1 |
| Safe Maintenance Practices | 1-2 |
| Read This Manual | 1-2 |
| Authorized Repair Personnel Only | 1-2 |
| Basic Crane Maintenance Safety | 1-2 |
| Before Starting a Maintenance Procedure | 1-2 |
| Precautions while Working on the Crane | 1-2 |
| Stored Energy Safety Precautions | 1-3 |
| Chemical Handling Precautions | 1-3 |
| Fire Hazard Precautions | 1-3 |
| Welding Hazard Avoidance | 1-3 |
| Maintain Structural Integrity of the Crane | 1-3 |
| Returning Crane to Service | 1-3 |
| Environmental Protection | 1-4 |
| Abbreviations | 1-4 |
| Identification and Location of Components | 1-5 |

Reference Only

THIS PAGE INTENTIONALLY LEFT BLANK

SECTION 1

INTRODUCTION



WARNING

California Proposition 65

Breathing diesel engine exhaust exposes you to chemicals known to the State of California to cause cancer and birth defects or other reproductive harm.

- Always start and operate the engine in a well-ventilated area.
- If in an enclosed area, vent the exhaust to the outside.
- Do not modify or tamper with the exhaust system.
- Do not idle the engine except as necessary.

For more information go to www.P65warnings.ca.gov/diesel.

Battery posts, terminals, and related accessories contain chemical lead and lead compounds, chemicals known to the State of California to cause cancer, birth defects, and other reproductive harm. Wash hands after handling.

California Spark Arrestor

Operation of this equipment may create sparks that can start fires around dry vegetation. A spark arrestor may be required. The owner/operator should contact local fire agencies for laws or regulations relating to fire prevention requirements.

CONTINUOUS INNOVATION

Due to continuing product innovation, the information in this manual is subject to change without notice. If you are in doubt about any procedure, contact your Manitowoc dealer or the Manitowoc Crane Care Lattice Team.

SAFETY MESSAGES

The importance of safe operation and maintenance cannot be over emphasized. Carelessness or neglect on the part of operators, job supervisors and planners, rigging personnel, and job site workers can result in their death or injury and costly damage to the crane and property.

To alert personnel to hazardous operating practices and maintenance procedures, safety messages are used throughout the manual. Each safety message contains a safety alert symbol and a signal word to identify the hazard's degree of seriousness.

Safety Alert Symbol



This is the safety alert symbol. It is used to alert you to potential personal injury hazards. **Obey all safety messages that follow this symbol to avoid possible death or injury.**

Signal Words



DANGER

Indicates a hazardous situation which, if not avoided, **will** result in *death or serious injury*.



WARNING

Indicates a hazardous situation which, if not avoided, **could** result in *death or serious injury*.



CAUTION

Used with the safety alert symbol, indicates a hazardous situation which, if not avoided, **could** result in *minor or moderate injury*.

CAUTION

The signal word CAUTION **without** the safety alert symbol identifies a hazardous situation which, if not avoided, **could** result in *property damage*.

SAFE MAINTENANCE PRACTICES



WARNING

Safety Responsibility

The importance of safe maintenance cannot be over emphasized. Carelessness and neglect on the part of maintenance personnel can result in their death or injury and costly damage to the crane or property.

Safety information in this publication is intended only as a guide to assist qualified maintenance personnel in safe maintenance. Manitowoc cannot foresee all hazards that will arise in field. Safety remains the responsibility of maintenance personnel and the crane owner.

Read This Manual

To ensure safe and proper operation of Manitowoc cranes, they must be maintained according to the instructions contained in this manual.

Authorized Repair Personnel Only

Crane maintenance and repair must be performed by personnel who by reason of training and experience are thoroughly familiar with the crane's operation and required maintenance. These personnel **must read the MLC165-1 Operator Manual and the MLC165-1 Service/Maintenance Manual before attempting any maintenance procedure**. If there is any question regarding maintenance procedures or specifications, contact your Manitowoc dealer for assistance.

Training/qualification of maintenance personnel is responsibility of crane owner.

Basic Crane Maintenance Safety

The following precautions are basic practices. Detailed precautions and warnings are in the relevant procedures in this manual. Be sure to read all information in this manual that is relevant to the maintenance to be performed.

Before Starting a Maintenance Procedure

Perform the following actions (as applicable) before starting a maintenance procedure:

- Park the crane where it will not interfere with other equipment or operations.
- Lower all loads to ground or otherwise secure them against movement.
- Lower the boom onto blocking at ground level, if possible, or otherwise secure the boom so that it cannot drop unexpectedly.

- Move all controls to off and secure all functions against movement by applying or engaging all brakes, pawls, or other locking devices.
- Stop the engine and render the starting means inoperative. This can be done by following your organization's tag-out procedure.
- Place a warning sign at the start controls to alert other personnel that the crane is being serviced and the engine must not be started. Do not remove the sign until it is safe to return the crane to service.
- Do not attempt to maintain or repair any part of the crane while the engine is running, unless it is absolutely necessary.

If the engine must be run, keep your clothing and all parts of your body away from moving parts. **Maintain constant verbal communication between the person at the controls and the person performing the maintenance or repair procedure.**

- Wear clothing that is relatively tight and belted.
- Wear appropriate eye protection and an approved hard hat.

Precautions while Working on the Crane

- Never climb onto or off a moving crane. **Climb onto and off the crane only when it is parked and only with the operator's permission.**

To climb onto and off crane, use both of your hands and also use the handrails, steps, and ladders that are provided.

Use hand lines or hoists to lift tools and other equipment which cannot be carried in pockets or tool belts.

- The boom and gantry are not intended as ladders. Do not attempt to climb the lattice work of the boom or gantry. If the boom or gantry is not equipped with an approved ladder, lower it before performing maintenance or repair procedures.
- Store tools, oil cans, spare parts, and other necessary equipment in tool boxes. Do not allow these items to lie around loose in the operator cab or on the walkways and stairs.
- Pinch points are impossible to eliminate. Watch for them closely.
- Do not attempt to lift heavy components by hand. Use a hoist, jacks, or blocking to lift components.
- Never handle the wire rope with bare hands. Always wear heavy-duty gloves to prevent being cut by broken wires.

Stored Energy Safety Precautions

- Do not remove an actuating cylinder until the actuated part has been securely restrained against movement.
- Pressurized air, coolant, and hydraulic oil can cause serious injury. Make sure all air, coolant, and hydraulic lines, fittings, and components are tight and serviceable.

Do not use your hands to check for air and hydraulic oil leaks:

- Use a soap and water solution to check for air leaks (apply to fittings and lines and watch for bubbles).
- Use a piece of cardboard or wood to check for coolant and hydraulic oil leaks.
- Relieve pressure before disconnecting air, coolant, and hydraulic lines and fittings.
- Use extreme care when handling coiled pendants. Stored energy can cause coiled pendants to uncoil quickly with considerable force.
- When inflating tires, use a tire cage, a clip-on inflater, and an extension hose which permits standing well away from tire.
- Do not remove the radiator cap while the coolant is hot or under pressure. Stop the engine, wait until the pressure drops and coolant cools, then slowly remove the cap.
- Avoid a battery explosion—do not smoke while performing battery maintenance and do not short across the battery terminals to check its charge.
- Read the safety information in the battery manufacturer's instructions before attempting to charge a battery.

Chemical Handling Precautions

- Avoid battery acid contact with skin and eyes. If contact occurs, flush the area with water and immediately consult a doctor.

Fire Hazard Precautions

- Stop the engine before refueling the crane.
- Do not smoke or allow open flames in the refueling area.
- When using a fuel can, use a safety-type can with an automatic closing cap and flame arrestor.
- Hydraulic oil can also be flammable. Do not smoke or allow open flames in the area when filling hydraulic tanks.
- Only use cleaning solvents which are non-volatile and non-flammable.
- Do not store flammable materials on the crane.
- Use care while welding or burning on the crane. Cover all hoses and components with non-flammable shields or blankets to prevent a fire or other damage.

- **Keep the crane clean.** Accumulations of dirt, grease, oil, rags, paper, and other waste will not only interfere with safe operation and maintenance but will also create a fire hazard.

Welding Hazard Avoidance

- Welding—To prevent damage to the crane parts (bearings, cylinders, swivels, slewing ring, computers, etc.), perform the following steps **before welding on crane:**
 - Open the battery disconnect switch.
 - Disconnect all the cables from the batteries.
 - Disconnect the output cables at the engine junction box.
 - Disconnect all cable connectors from nearby controller nodes.
 - Attach a ground cable from the welder directly to the part being welded and as close to the weld as possible.

Do not weld on the engine or the engine-mounted parts (per engine manufacturer).

- Disconnect and lock-out the power supply switch before attempting to service high-voltage electrical components and before entering tight areas (such as carbody openings) containing high voltage components.

Maintain Structural Integrity of the Crane

- When assembling and disassembling booms, jibs, or masts on the ground (with or without the support of boom rigging pendants or straps), securely block each section to provide adequate support and alignment.

Do not go under the boom, jib, or mast sections while connecting bolts or pins are being removed.

- Unless authorized in writing by Manitowoc, do not alter the crane in any way that affects the crane's performance (to include welding, cutting, or burning of structural members or changing pressures and flows of air/hydraulic components). Doing so will invalidate all warranties and capacity charts and make the crane owner/user liable for any resultant accidents.

Returning Crane to Service

- Do not return the crane to service until:
 - All guards and covers have been reinstalled
 - Trapped air has been bled from hydraulic systems
 - Safety devices have been reactivated
 - All tools and maintenance equipment have been removed.
- Perform a function check to ensure proper operation at the completion of the maintenance or repair.

ENVIRONMENTAL PROTECTION



WARNING

Environmental Damage

Dispose of waste properly! Improperly disposing of waste can cause environmental damage.

Potentially harmful waste used in Manitowoc cranes includes—but is not limited to—oil, fuel, grease, coolant, air conditioning refrigerant, filters, batteries, and cloths which have come into contact with harmful substances.

Handle and dispose of waste according to local, state, and federal environmental regulations.

When filling and draining crane components, do not pour waste fluids onto the ground, down any drain, or into any source of water.

- Always drain waste fluids into leak-proof containers that are clearly marked with what they contain.
- Always fill or add fluids with a funnel or a filling pump.
- Immediately wipe up any spills.

ABBREVIATIONS

The following abbreviations are used throughout this manual.

| | |
|---------|--|
| A | Amber Light |
| ACR | Air Conditioning Relay |
| AL | Auto Lube Pump |
| ALT | Alternator |
| AUX | Auxiliary |
| BH | Boom Hoist |
| CAN-bus | Controller Area Network |
| DISP | Displacement |
| ECOR | Electric Compensated Over-Ride |
| EDC | Electrical Displacement Control (Pump) |
| EFC | Electronic Fuel Control |
| EPIC | Electrical Processed Independent Control |
| FS | Fuel Solenoid |
| FF | Free Fall |
| FSR | Fuel Solenoid Relay |
| G | Green Light |
| GND | Ground (Electrical) |
| HDC | Hydraulic Displacement Control |
| HS | Hydraulic Solenoid |
| LD | Load Drum |
| LJ | Luffing Jib |
| LT | Left Travel |
| MAX | Maximum |
| M/C | Motor Control |
| MIN | Minimum |
| P/C | Pump Control |
| PCOR | Pressure Compensated Over-Ride |
| PCP | Pressure Control Pilot (Motor) |
| PWR | Power (Electrical) |
| R | Red Light |
| RT | Right Travel |
| S | Swing |
| SOL | Solenoid |
| SS | Starter Solenoid |
| VDC | Volts Direct Current |
| W | White Light |

IDENTIFICATION AND LOCATION OF COMPONENTS

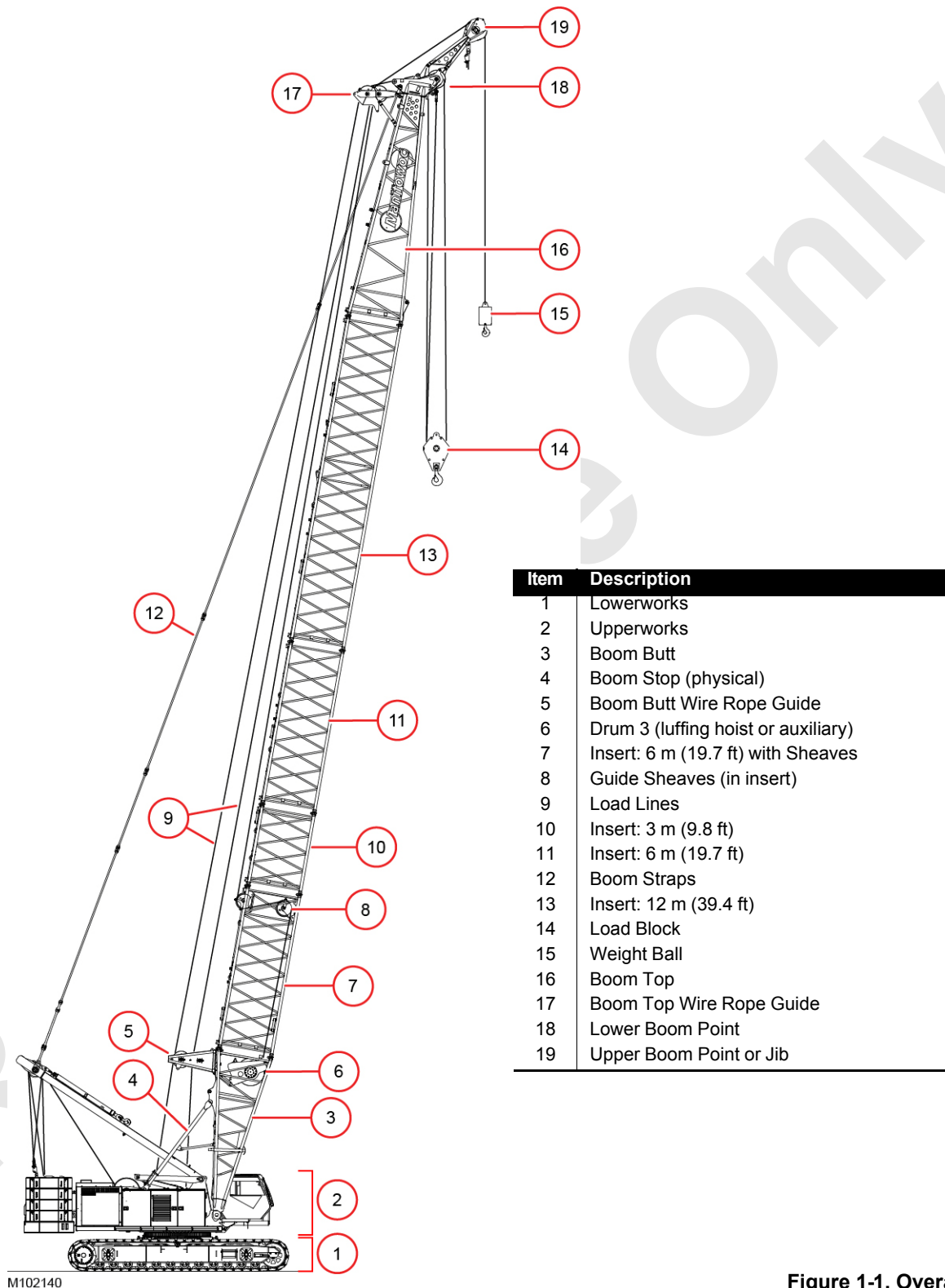
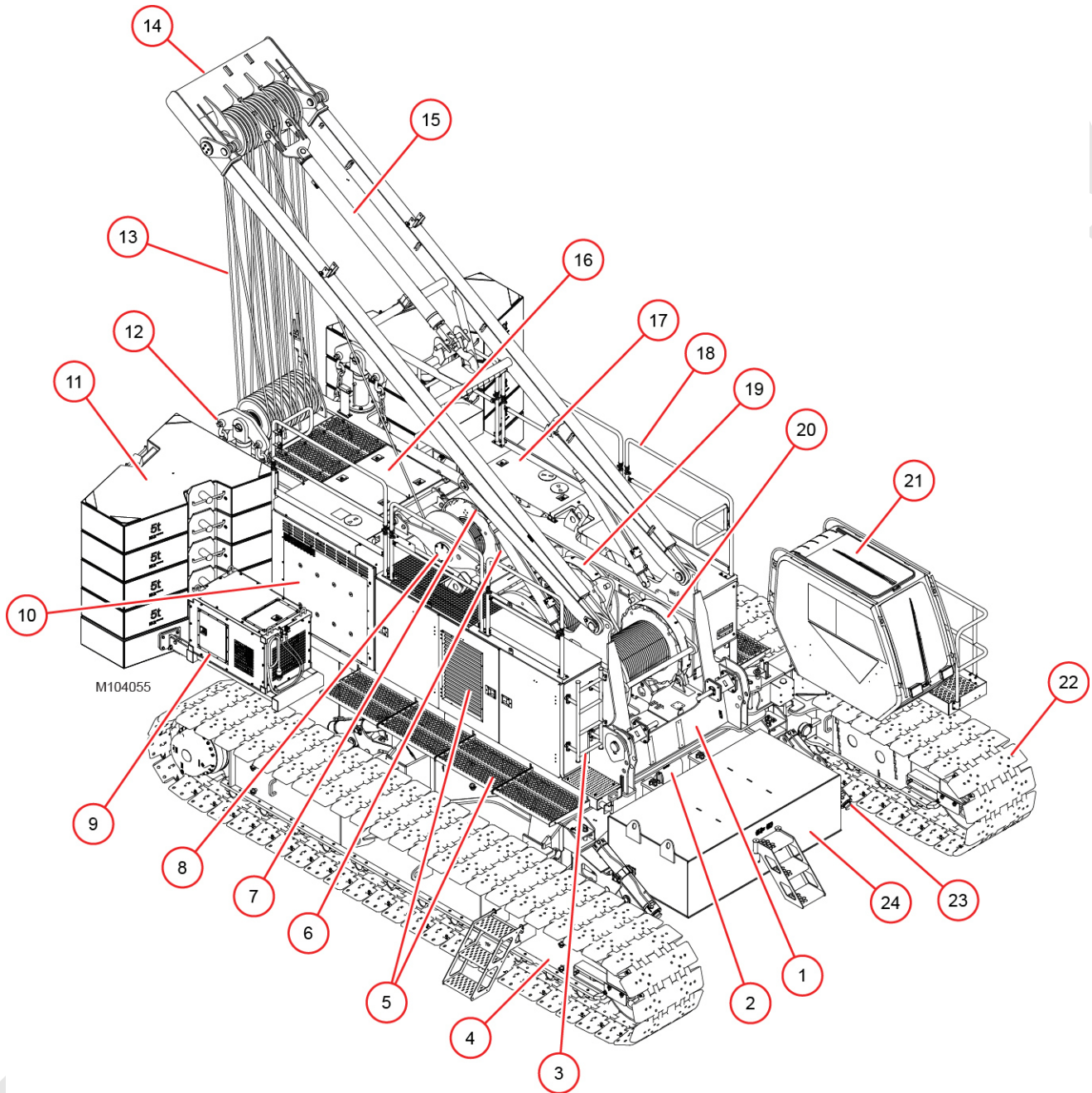

Figure 1-1. Overall View



The legend is on next page.

Figure 1-2. Right Side View

Legend for [Figure 1-2](#)

| Item | Description |
|------|--|
| 1 | Rotating Bed |
| 2 | Carbody |
| 3 | Ladder (optional) |
| 4 | Right Crawler |
| 5 | Right Enclosure with Platform (see NOTE) |
| 6 | Mast-Assist Cylinder (both sides) |
| 7 | Mast-Assist Arm (both sides) |
| 8 | Drum 4 (boom hoist) |
| 9 | Generator (optional) |
| 10 | Radiator and Coolers |
| 11 | Crane Counterweights |
| 12 | Counterweight Handling Cylinder |
| 13 | Boom Hoist Wire Rope |
| 14 | Mast |
| 15 | Self-Assembly Cylinder |
| 16 | Engine Enclosure |
| 17 | Left Enclosure with Platform: |
| 18 | Handrail (optional both sides) |
| 19 | Drum 2 (rear drum) |
| 20 | Drum 1 (front drum) |
| 21 | operator cab Platform and Railings |
| 22 | Left Crawler |
| 23 | Carbody Jack (4) |
| 24 | Carbody Counterweight (Series 2 option) |

NOTE The Right Enclosure covers the following:

- Battery Charger
- Batteries
- Nodes 4 and 5
- Fire Extinguisher (CE only)
- Free Fall Valves and Drives (Drum 1 and 2)
- Setup Remote Control
- DEF Tank and Valves
- Fuel Tank and Primary Filter
- Auto Lube Pump

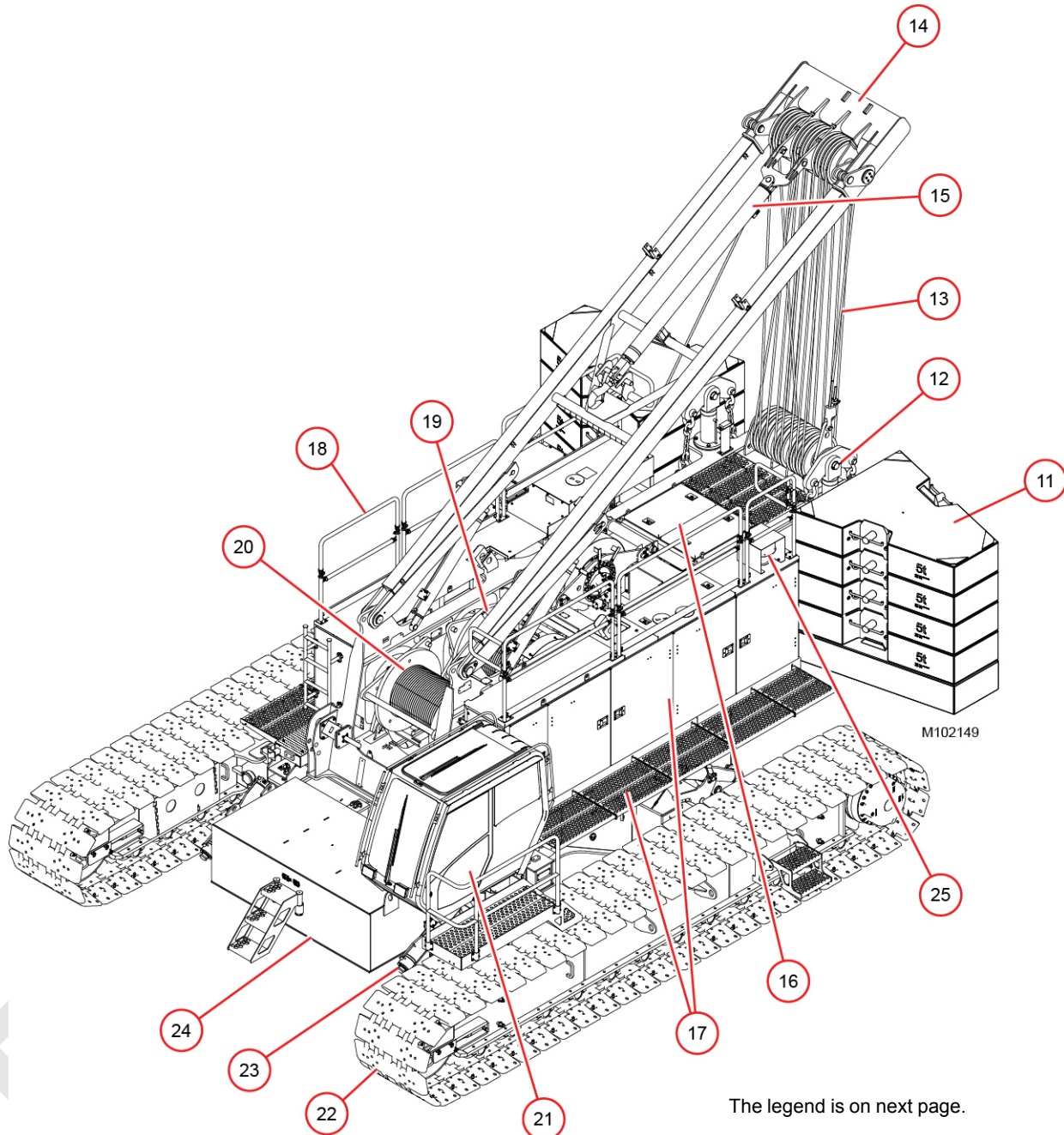

Figure 1-3. Left Side

Legend for [Figure 1-3](#)

| Item | Description |
|------|---|
| 1-10 | Figure 1-2 |
| 11 | Crane Counterweights |
| 12 | Counterweight Handling Cylinder |
| 13 | Boom Hoist Wire Rope |
| 14 | Mast |
| 15 | Self-Assembly Cylinder |
| 16 | Engine Enclosure |
| 17 | Left Enclosure with Platform (see NOTE) |
| 18 | Handrail (optional both sides) |
| 19 | Drum 2 (rear drum) |
| 20 | Drum 1 (front drum) |
| 21 | operator cab Platform and Railings |
| 22 | Left Crawler |
| 23 | Carbody Jack (4) |
| 24 | Carbody Counterweight (Series 2 option) |
| 25 | Engine Air Cleaner |

NOTE The Left Enclosure covers the following:

- Drum 1 Drive (front drum)
- Pilot Signal Manifold
- Main Control Valve Manifold
- Node 3
- Drum 2 Drive (rear drum)
- Swing Drive
- Pilot Brake and Pawl Manifold
- Hydraulic Tank
- Hydraulic Pumps and Pump Drive
- Engine and Pump Drive

THIS PAGE INTENTIONALLY LEFT BLANK

Reference Only

SECTION 2 HYDRAULIC SYSTEM

TABLE OF CONTENTS

| | |
|--|------|
| Hydraulic System Overview | 2-1 |
| Hydraulic Pump Locations | 2-1 |
| Main Pump | 2-2 |
| Swing Pump | 2-3 |
| Accessory Pump | 2-4 |
| Free Fall Cooling Pump | 2-4 |
| Fan Cooling Pump | 2-5 |
| Drum 1 and 2 Motors | 2-6 |
| Drum 3 and 4 Motors | 2-6 |
| Swing Motor | 2-7 |
| Cooling Fan Motor | 2-7 |
| Travel Motors | 2-8 |
| Main Control Valve Manifold | 2-9 |
| Pilot Brake and Pawl Manifold | 2-10 |
| Accessory Manifold | 2-11 |
| Pilot Signal Manifold | 2-12 |
| Free Fall Manifold | 2-13 |
| Cooler Bypass Manifold | 2-13 |
| Hydraulic System Specifications | 2-15 |
| Hydraulic System Maintenance | 2-16 |
| Safety | 2-16 |
| Storing and Handling Oil | 2-16 |
| Storing and Handling Parts | 2-16 |
| Inspecting the Hydraulic System | 2-17 |
| Inspecting and Replacing Hydraulic Hoses | 2-18 |
| Tightening Hydraulic Connections | 2-19 |
| Replacing Desiccant Breather Cartridge | 2-24 |
| Replacing Return Filters | 2-25 |
| Replacing Pilot Filter | 2-26 |
| Replacing the Swing Filter | 2-27 |
| Changing the Hydraulic Oil | 2-29 |
| Servicing the Pumps | 2-30 |
| Replacing a Pressure Transducer | 2-30 |
| Hydraulic Tests and Calibrations | 2-31 |
| Travel Speed Test | 2-31 |
| Swing Speed Test | 2-32 |
| Pressure Transducer Test | 2-33 |
| Controls Calibration | 2-34 |
| Drum Brake Test | 2-35 |
| Swing Brake Test | 2-35 |

THIS PAGE INTENTIONALLY LEFT BLANK

SECTION 2

HYDRAULIC SYSTEM

HYDRAULIC SYSTEM OVERVIEW

This section provides a physical description and general functional overview of the major hydraulic components. The detailed description of the control and operation using these

components to form working circuits be found in the appropriate functional sections of this manual.

Hydraulic Pump Locations

There are five hydraulic pumps driven by the engine. [Figure 2-1](#) illustrates the location of these pumps.

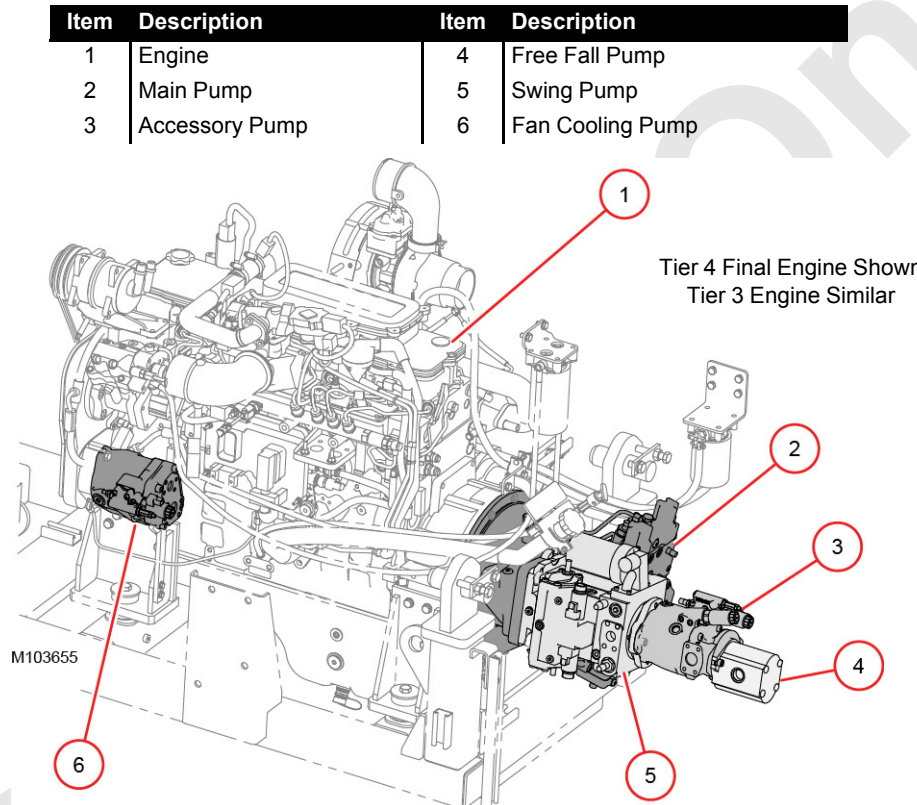

Figure 2-1. Hydraulic Pump Locations

Main Pump

The main pump (Figure 2-2) is part of the open hydraulic system and contains two variable-displacement pumps. These pumps provide flow to the main control valve manifold. The pump displacements are hydraulically controlled by load-sensing and horsepower limiting circuits within the pump.

The hydraulic load-sensing and horsepower sensing circuits can be over-riden by load-sensing override solenoid HS-

304 and horsepower override solenoid HS-303, which are activated by node 3. The load-sensing override function is not currently used. In horsepower override, software control uses the engine speed and fuel consumption rate to adjust the pump power consumption in order to prevent overloading the engine.

The main pump also contains a third fixed-displacement pump. This pump provides flow to the pilot circuit.

| Item | Description | Item | Description |
|--------|---|------|--|
| A1, A2 | Service Ports | X4 | Control Pressure Port for load-sensing |
| R1, R3 | Air Bleed Ports | M1 | Gauge Port A1 |
| X6 | Control Pressure Port for load-sensing - Shifting | M2 | Gauge Port A2 |
| X3 | Control Pressure Port for Power Override | M | Gauge Port |
| A3 | Service Port (auxiliary pump) | R2 | Oil Drain |
| M3 | Gauge Port for Power Override (plugged in normal operation) | S | Suction Port |

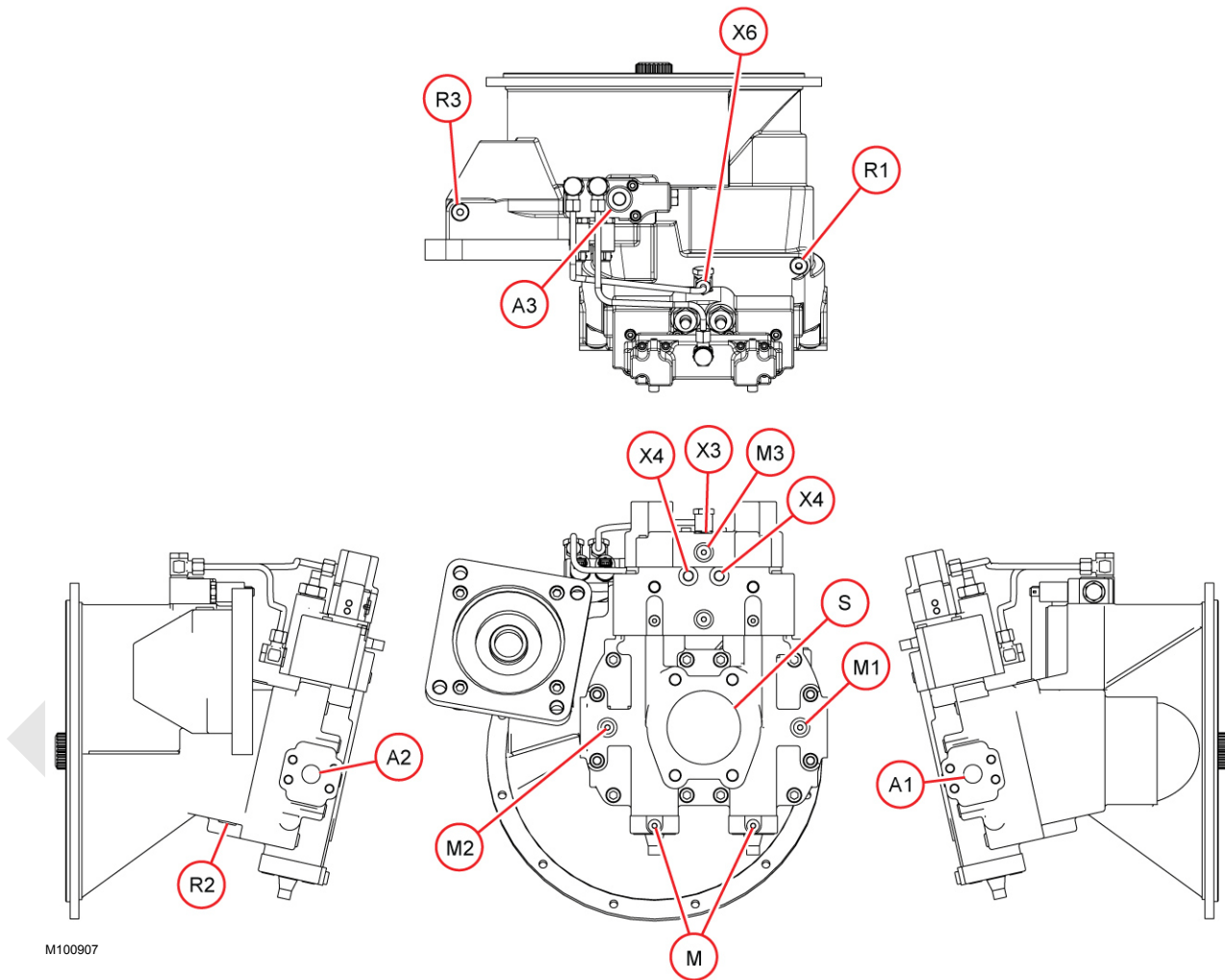

Figure 2-2. Main Pump

Swing Pump

The swing pump (Figure 2-3) is part of a closed system containing the swing pump and motor. Swing pump flow is both directional and variable, as controlled by position and

proportional solenoid valves at the swing pump. See [Swing Pump Control on page 6-3](#) for a detailed description of the swing pump and swing system control.

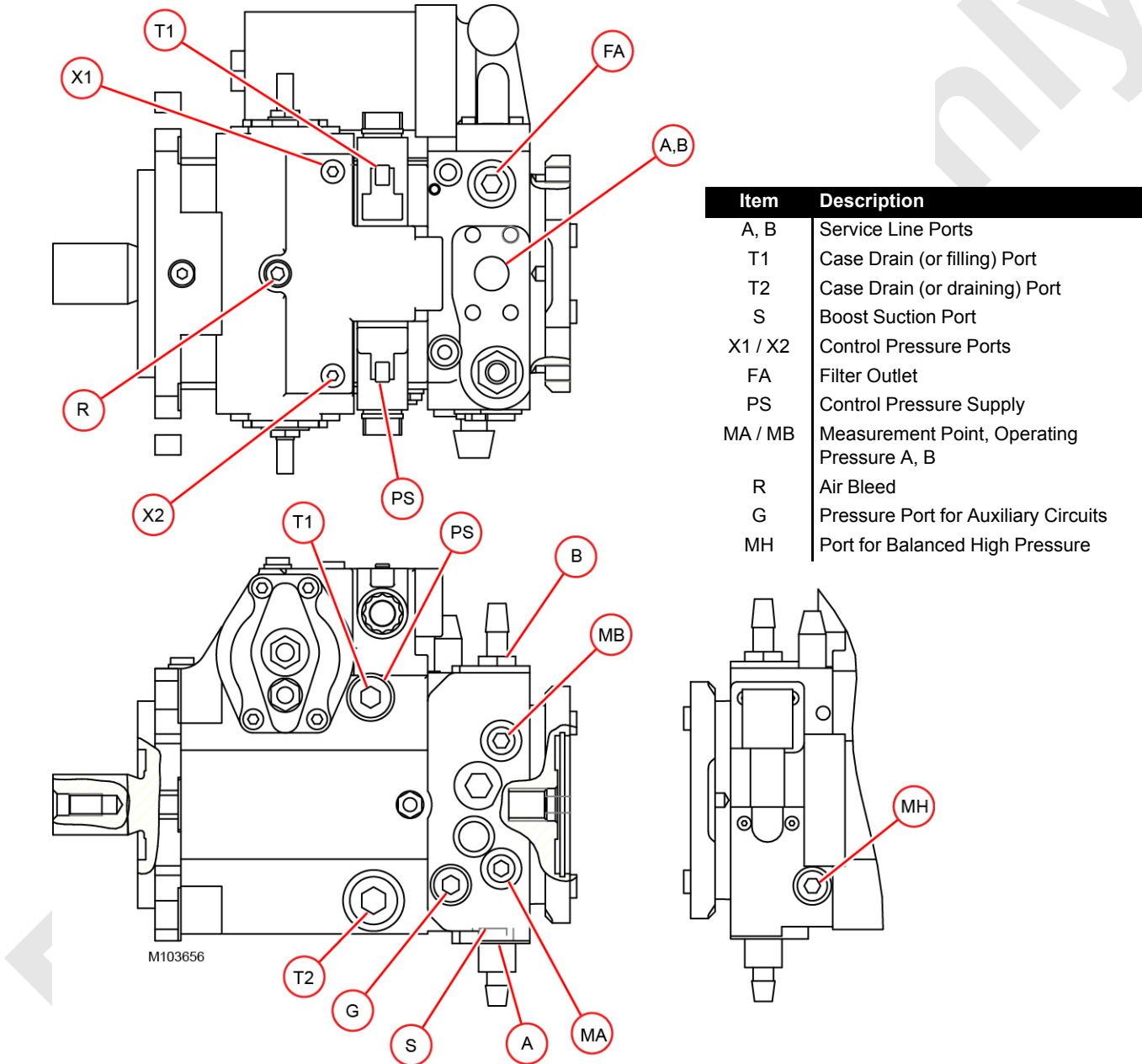

Figure 2-3. Swing Pump

Accessory Pump

The accessory pump (Figure 2-4) is a variable-displacement, pressure compensated pump which provides flow to the accessory manifold. The displacement is controlled by proportional solenoid valve HS-502, driven by node 5. The control system reads the accessory pressure transducer, located in the accessory valve manifold, and drives the pump displacement to provide the correct pressure for the accessory being used.

| Item | Description |
|------|-----------------------------|
| B | Pressure Port (out) |
| S | Suction Port (in) |
| L1 | Case Drain Ports (plugged) |
| L1 | Case Drain Port (unplugged) |

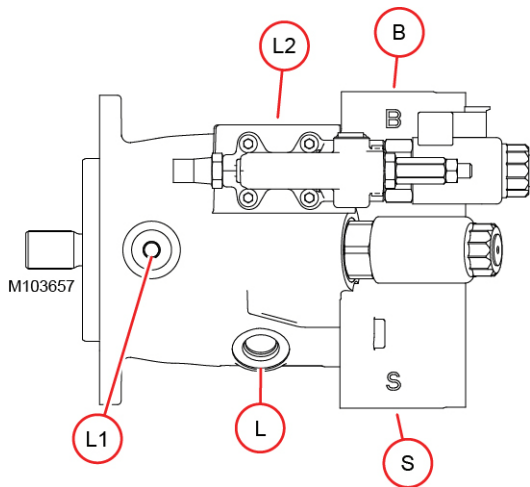

Figure 2-4. Accessory Pump

Free Fall Cooling Pump

The free fall cooling pump (Figure 2-5) is part of the open hydraulic system and is a fixed-displacement pump that provides cooling flow to the free fall manifold.

| Item | Description |
|------|-------------|
| A | Inlet Port |
| B | Outlet Port |

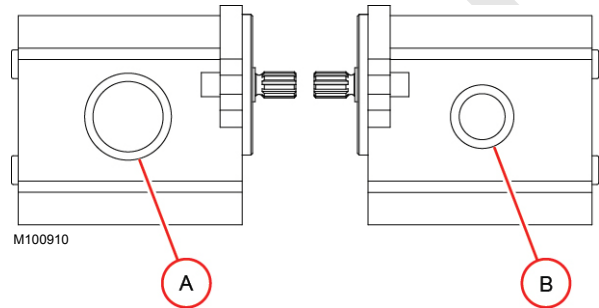

Figure 2-5. Free Fall Cooling Pump

Fan Cooling Pump

The fan cooling pump ([Figure 2-6](#)) is part of the open hydraulic system and is a variable-displacement pump that provides flow to the cooling fan motor. The displacement is controlled by a solenoid valve HS-504, driven by node 5. The control software uses the following inputs to determine where to set the pump displacement:

- Fan cooling pump pressure
- Hydraulic tank temperature
- Engine coolant temperature
- Air intake temperature
- AC compressor switch setting

| Item | Description |
|-------|------------------|
| B | Outlet Port |
| L, L1 | Case Drain Ports |
| S | Inlet Port |

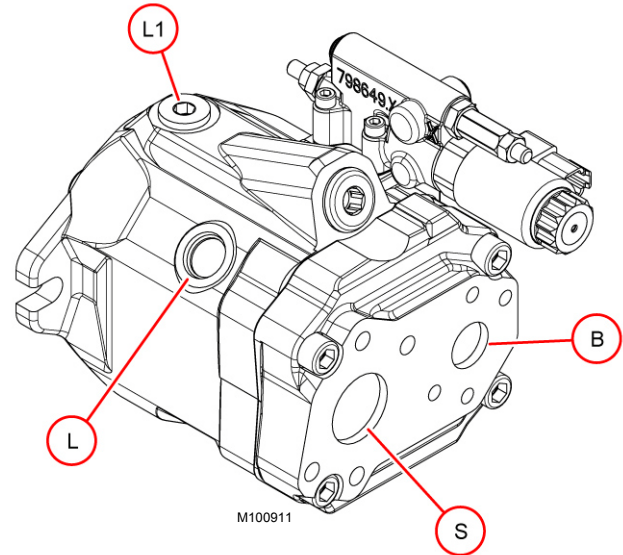

Figure 2-6. Fan Cooling Pump Components

Drum 1 and 2 Motors

Figure 2-7 illustrates the motor for each drum, 1 and 2. See Drum 1 and Drum 2 Motor on page 5-5 for a detailed operational description of the Drum 1 and 2 systems.

| Item | Description |
|--------|------------------------------|
| A, B | Pressure Ports |
| T1, T2 | Case Drain Ports |
| U | Bearing Flushing / Air Bleed |
| G | Synchronous Control |
| M1 | Measuring Stroking Chamber |

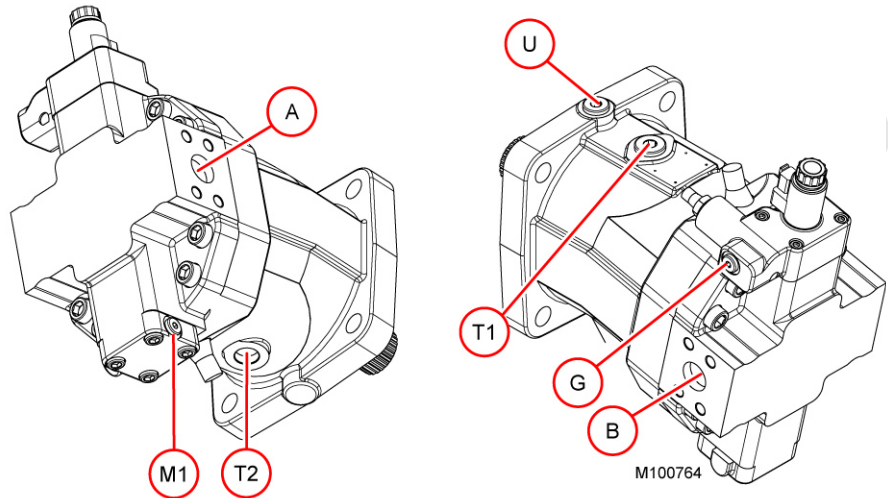

Figure 2-7. Drum 1 and 2 Motor Components

Drum 3 and 4 Motors

Figure 2-8 illustrates the motor for each drum, 3 and 4. See Drum 3 and Drum 4 Motor on page 5-7 for a detailed operational description of the Drum 3 and 4 systems.

| Item | Description |
|--------|-----------------------------|
| A, B | Pressure Ports |
| T | Case Drain Port |
| MA, MB | Measuring Pressures A and B |

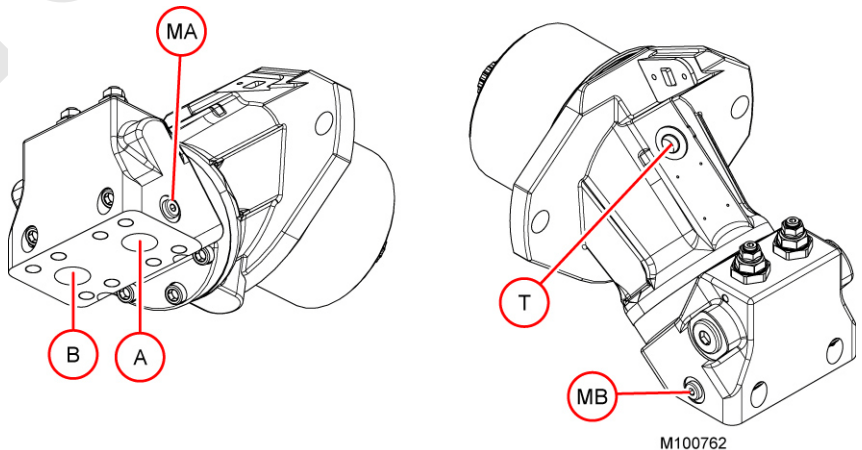

Figure 2-8. Drum 3 and 4 Motor Components

Swing Motor

Figure 2-9 illustrates the swing motor. See [Swing System Overview on page 6-1](#) for a detailed operational description of the swing system.

| Item | Description |
|--------|------------------|
| A, B | Pressure Ports |
| T1, T2 | Case Drain Ports |

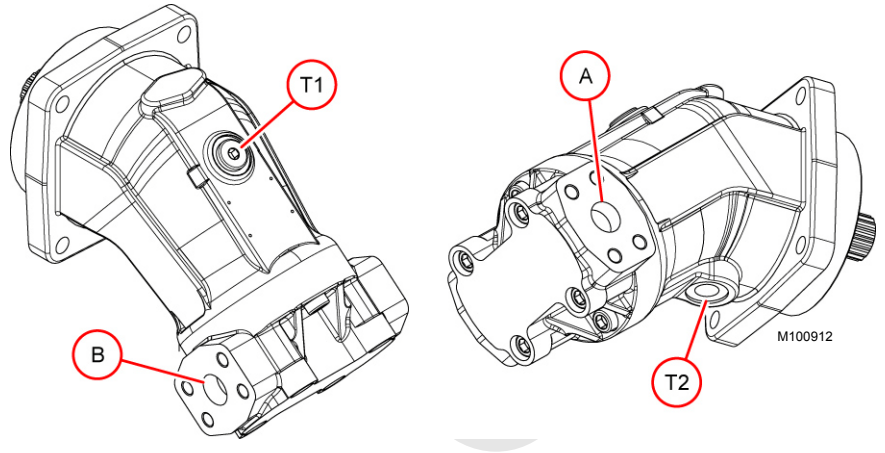

Figure 2-9. Swing Motor

Cooling Fan Motor

The cooling fan motor ([Figure 2-10](#)) is a fixed-displacement motor that rotates the cooling fan. The motor is driven by the fan-cooling pump. illustrates the fan motor.

| Item | Description |
|-------|------------------|
| A, B | Pressure Ports |
| L, L1 | Case Drain Ports |

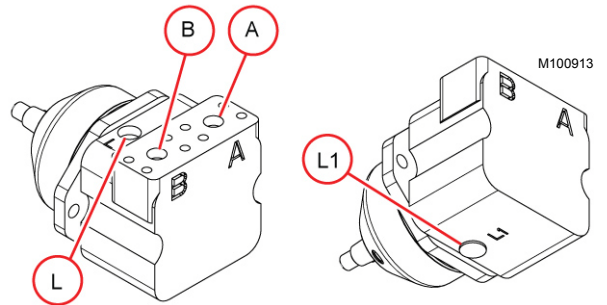

Figure 2-10. Cooling Fan Motor

Travel Motors

Figure 2-11 illustrates the travel motor. See [Travel Overview on page 8-1](#) for a detailed operational description of the travel system.

| Item | Description | Item | Description |
|------|--------------------------------|--------|-------------------------------|
| A, B | Pressure Ports | MA, MB | Measuring Pressures for A & B |
| X | Pilot Port for 2-Speed Control | T1, T2 | Case Drain Ports |
| Bre | Brake Release Port (external) | | |

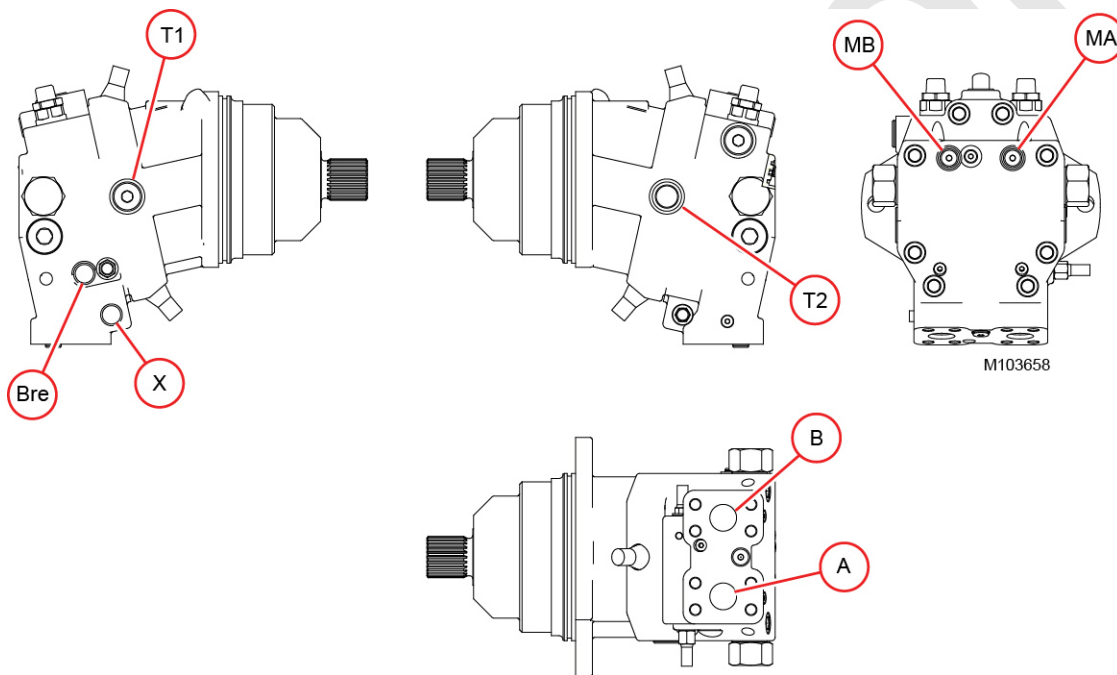

Figure 2-11. Travel Motor

Main Control Valve Manifold

The main control valve manifold (Figure 2-12) controls flow to the drum and travel motors. Each rotary group of the main pump generates flow to the main control valve manifold.

At times it may be desirable to combine the two flows. This can be done with the Drum 1/2 high speed switch in the cab. When the switch is moved to the high speed position, node 3 energizes solenoid valve HS-302 located in the control valve

manifold. The solenoid valve shifts an on-off valve which connects the load sense and working pressure flows within the two halves of the control valve manifold.

When the high speed switch is in the on position, both of the main pump flows feed all drum and travel motors. In the off position, each flow separately supplies two drum motors and one travel motor.

| Item | Description |
|------|---------------------------|
| 1 | Drum 3 (aux/luffing drum) |
| 2 | Drum 2 (rear load drum) |
| 3 | Right Travel |
| 4 | Left Travel |
| 5 | Drum 4 (boom hoist) |
| 6 | Drum 1 (front load drum) |
| 7 | Combined Flow |

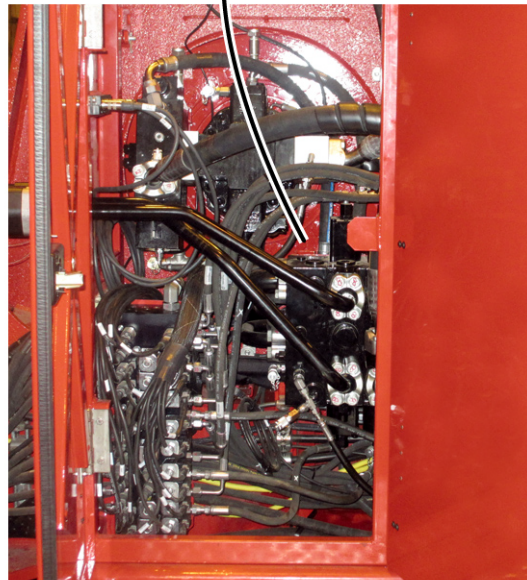
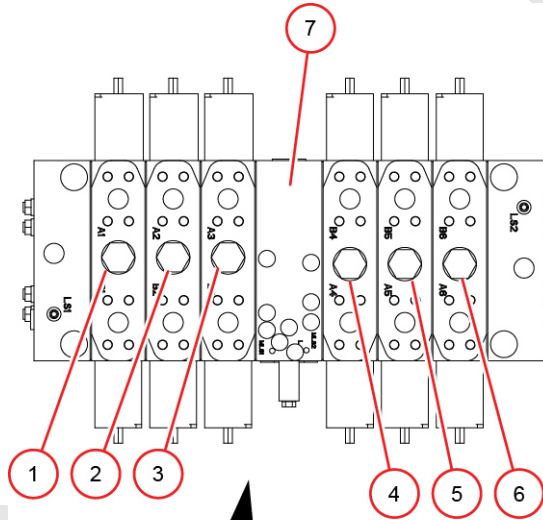

M103659

Left-Side Enclosure

Figure 2-12. Main Control Valve

Pilot Brake and Pawl Manifold

The pilot brake and pawl manifold receives flow from the charge pump within the main pump. Solenoid valves in the manifold control flow to the brake and pawl functions listed in [Figure 2-13](#).

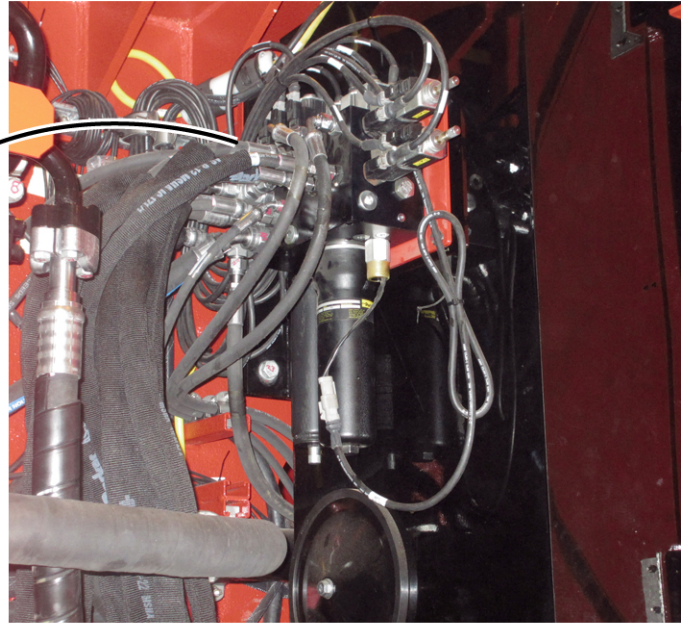
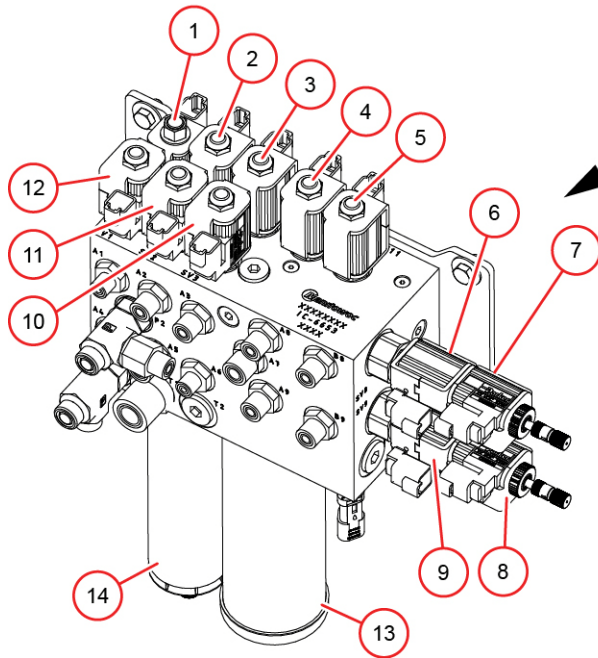

M103660

Left-Side Enclosure on Hydraulic Tank

| Item | Description | Item | Description |
|------|------------------------------------|------|------------------------------------|
| 1 | Travel Pilot | 8 | Drum 1 Pawl Disengage (front drum) |
| 2 | Travel Hi-Speed | 9 | Drum 1 Pawl Engage (front drum) |
| 3 | Drum 4 Brake (boom hoist) | 10 | Drum 1 Brake (front drum) |
| 4 | Drum 3 Brake (aux drum) | 11 | Drum 2 Brake (rear drum) |
| 5 | Pilot Pressure Unloading | 12 | Swing Brake |
| 6 | Drum 4 Pawl Engage (boom hoist) | 13 | Filter |
| 7 | Drum 4 Pawl Disengage (boom hoist) | 14 | Accumulator |

Figure 2-13. Pilot Brake and Pawl Manifold

Accessory Manifold

The accessory manifold receives flow from the accessory pump. Solenoid valves in the manifold control flow to the accessory cylinders listed in [Figure 2-14](#). The lower

accessory valve, HS-502, of the manifold is driven by node 5. When the operator enables the manual valves from the main display screen, HS-502 opens, providing flow to the carbody valve manifold.

| Item | Description |
|------|---|
| 1 | Mast-Assist Arm Cylinder Extend |
| 2 | Mast-Assist Arm Cylinder Retract |
| 3 | Self-Assembly Cylinder Extend |
| 4 | Self-Assembly Cylinder Retract |
| 5 | Counterweight Inner Pins Extend |
| 6 | Counterweight Inner Pins Retract |
| 7 | Boom Hinge Pins Extend |
| 8 | Boom Hinge Pins Retract |
| 9 | Cab Tilt Cylinder Extend |
| 10 | Cab Tilt Cylinder Retract |
| 11 | Lower Accessories Enable |
| 12 | Left Counterweight-Handling Cylinder Extend |
| 13 | Left Counterweight-Handling Cylinder Retract |
| 14 | Accessories Pressure Transducer |
| 15 | Warning Circuit Enable |
| 16 | Right Counterweight-Handling Cylinder Extend |
| 17 | Right Counterweight-Handling Cylinder Retract |
| 18 | Rigging Winch In |
| 19 | Rigging Winch Out |

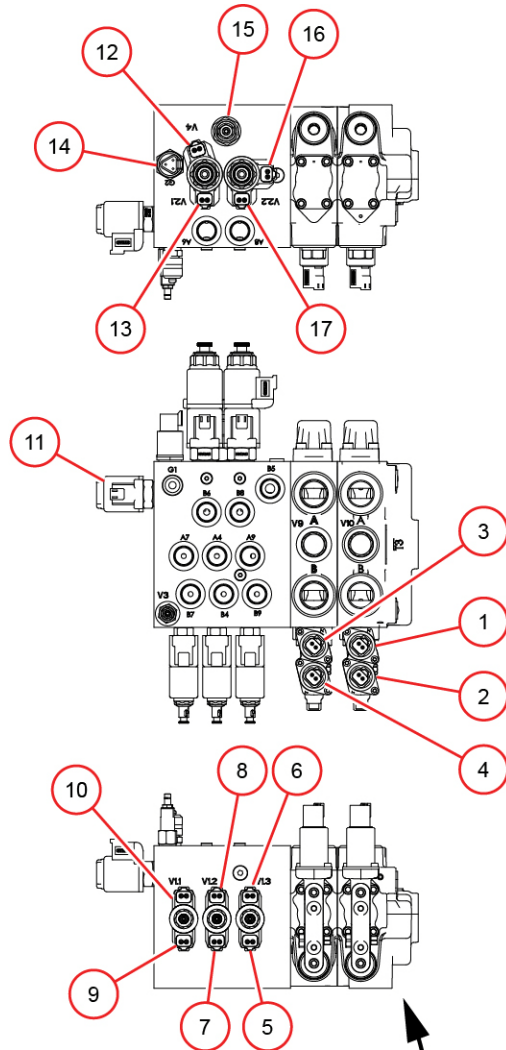

Under Rear of Rotating Bed Looking Forward

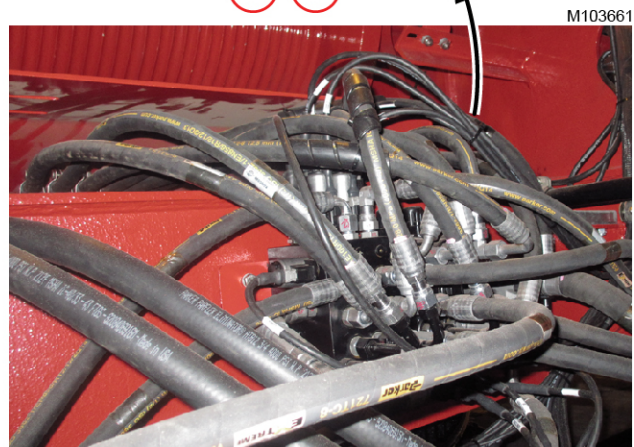
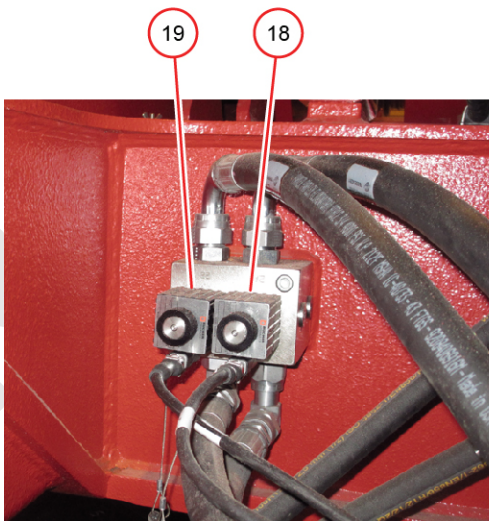

M103661

Figure 2-14. Accessory Manifold

Pilot Signal Manifold

The pilot signal manifold (Figure 2-15) receives flow from each hydraulic proportional control handle in the cab. Pressures transducers allow the control system to read the pressures produced by the proportional control handles.

Solenoid valves SV1–SV8 allow the control system to configure which handles control which drum functions. Proportional solenoid valves PV1–P8 allow the control system to override the hydraulic flow commands of the handles.

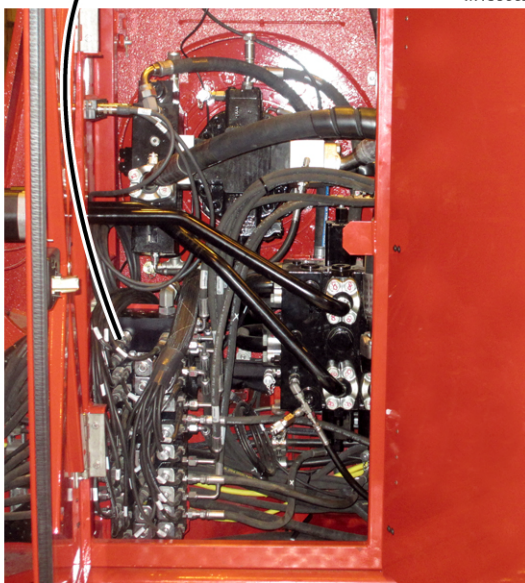
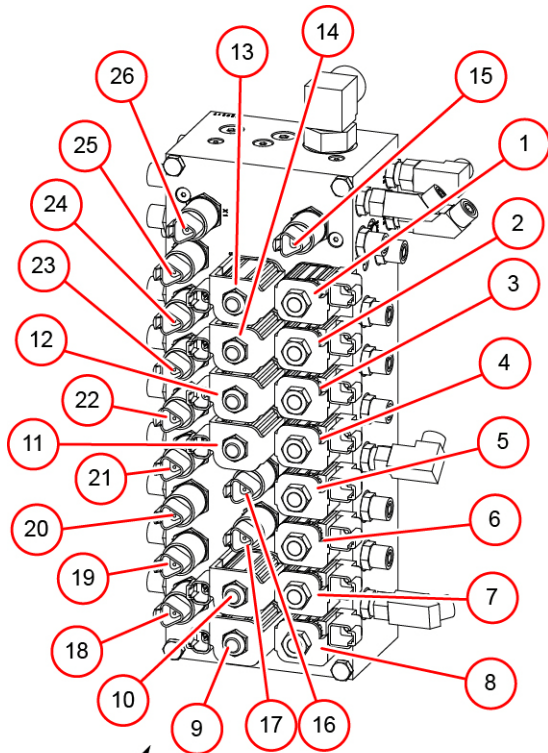

Front of Left-Side Enclosure

| Item | Description |
|--|-------------------------------|
| Proportional Pressure Reducing Solenoid Valves | |
| 1 | Boom Up |
| 2 | Boom Down |
| 3 | Front Drum Up |
| 4 | Front Drum Down |
| 5 | Rear Drum Up |
| 6 | Rear Drum Down |
| 7 | Aux Drum Up |
| 8 | Aux. Drum Down |
| Directional Control Solenoid Valves (normally closed) | |
| 9 | Select Handle 4y to Aux Down |
| 10 | Select Handle 4y to Aux Up |
| 11 | Select Handle 4y To Whip Down |
| 12 | Select Handle 4y To Whip Up |
| 13 | Select Handle 3 Boom Up |
| 14 | Select Handle 3 Boom Down |
| Pressure Transducers | |
| 15 | Handle 6 |
| 16 | Handle 2 Up |
| 17 | Handle 2 Down |
| 18 | Handle 3 Down |
| 19 | Handle 3 Up |
| 20 | Handle 4x Left |
| 21 | Handle 4x Right |
| 22 | Handle 1 Down |
| 23 | Handle 1 Up |
| 24 | Handle 4 Down |
| 25 | Handle 4 Up |
| 26 | Handle 5 |

Figure 2-15. Pilot Signal Manifold

Free Fall Manifold

The free fall manifold is illustrated in [Figure 2-16](#).

Front of Right-Side Enclosure

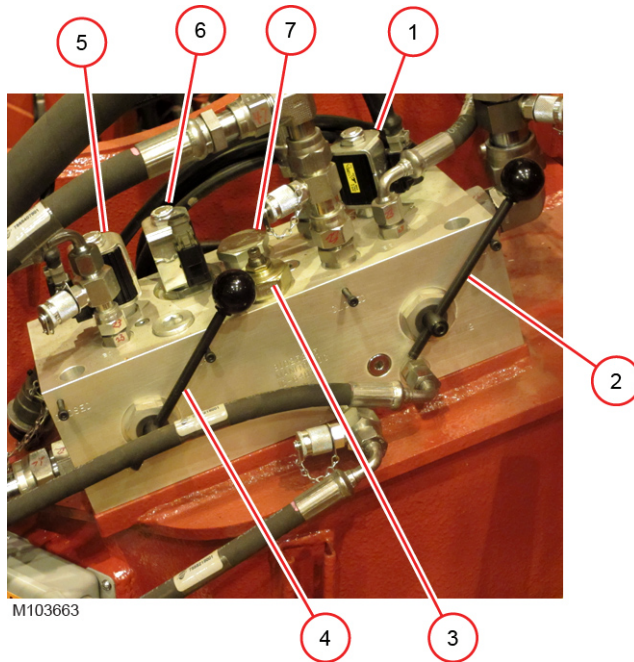

| Item | Description |
|------|---|
| 1 | Drum 1 Free Fall Enable Solenoid Valve |
| 2 | Drum 1 Free Fall Selector Valve |
| 3 | Relief Valve |
| 4 | Drum 2 Free Fall Selector Valve |
| 5 | Drum 2 Free Fall Enable Solenoid Valve |
| 6 | Free Fall Brake Cooling Valve (always open) |
| 7 | Check Valve |

Figure 2-16. Free Fall Manifold

Cooler Bypass Manifold

The hydraulic oil cooler bypass manifold is illustrated in [Figure 2-17](#).

Under Rear of Rotating Bed Looking Rearward

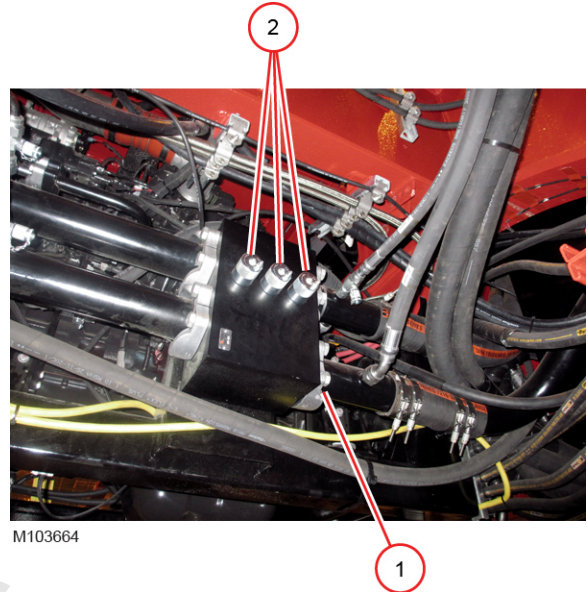

| Item | Description |
|------|----------------------|
| 1 | Relief Valve |
| 2 | Thermostat Valve (3) |

Figure 2-17. Cooler Bypass Manifold

THIS PAGE INTENTIONALLY LEFT BLANK

Hydraulic System Specifications

Table 2-1 Hydraulic Specifications

| | Direction | Valve/Pump Port | System Pressure 1 ¹ psi (bar) | System Pressure 2 psi (bar) | Pilot Pressure psi (bar) | Speed ³ rpm | | | | | | | | |
|---|-----------|-----------------|---|--------------------------------|-----------------------------|---------------------------|----|----|----|------------------|---|----|-----------------------|-----|
| Drum 1 | Up | Valve B6 | 5,076 (350) | NA | 507 (35) | 53 | | | | | | | | |
| | Down | Valve A6 | 1,450 (100) | | | 50 | | | | | | | | |
| Drum 2 | Up | Valve A2 | 5,076 (350) | | NA | | 53 | | | | | | | |
| | Down | Valve B2 | 1,450 (100) | | | | 50 | | | | | | | |
| Drum 3 | Up | Valve A1 | 5,076 (350) | | | NA | | 25 | | | | | | |
| | Down | Valve B1 | 1,450 (100) | | | | | 25 | | | | | | |
| Drum 4 | Up | Valve B5 | 5,076 (350) | | | | NA | | 25 | | | | | |
| | Down | Valve A5 | 1,450 (100) | | | | | | 25 | | | | | |
| Right Crawler | Forward | Valve A3 | 5,076 (350) | | | | | NA | | 10 at Tumbler | | | | |
| | Reverse | Valve B3 | | | | | | | | | | | | |
| Left Crawler | Forward | Valve A4 | | | | | | | | | | | | |
| | Reverse | Valve B4 | | | | | | | | | | | | |
| Swing | Left | Pump B | | | | | | | | | 5,221 (360) | NA | 363 (25) ⁴ | 2.5 |
| | Right | Pump A | | | | | | | | | | | | |
| High Pressure Accessory System ⁵ Assembly Cylinder | NA | NA | 350 (24) to 3,626 (250) | NA | | | | | NA | NA | | | | |
| | | | | | | | | | | | 600 (41) to 3,400 (234) ^{2, 7, 8} | | | |
| | | | 600 (41) to 1,800 (124) ^{2, 7, 8} | | | | | | | | | | | |
| Carbody Control System ⁶ | NA | NA | NA | | NA | | | | NA | NA | | | | |
| | | | 600 (41) to 3,400 (234) ^{2, 7, 8} | | | | | | | | | | | |
| | | | 600 (41) to 1,800 (124) ^{2, 7, 8} | | | | | | | | | | | |

NOTES

| | |
|----|---|
| NA | Not Applicable. |
| 1 | Controlled by multi-function valves in each pump. Max values given. Pressures are load dependent. |
| 2 | Controlled by crane's programmable controller. |
| 3 | Speeds based on engine at high idle, no load (no rope on drums), and handles moved fully forward or back. Speeds can vary plus or minus 5%. |
| 4 | Swing charge pressure (also called boost pressure). |
| 5 | Mast raising cylinder, boom butt pin cylinder, counterweight lift cylinders, cab tilt cylinder, counterweight pin puller cylinders. |
| 6 | Jack cylinders and carbody pin puller cylinders. |
| 7 | During free fall: 1,000 psi (69 bar) at 100% slip to 250 psi (17 bar) at 25% slip. |
| 8 | 500 - 900 psi (34 to 62 bar) while lowering the mast over the assist cylinders (control system synchronizes mast cylinders and hauling in on the boom hoist). |

HYDRAULIC SYSTEM MAINTENANCE

Only experienced technicians, trained in the operation of this crane and its hydraulic system, shall perform the procedures described in this section. The technicians shall read, understand, and comply with the instructions in this section and the display screen instructions in the Manitowoc MLC165-1 Main Display Operation manual.

Contact your Manitowoc dealer for an explanation of any procedure not fully understood.

Safety

Lower or securely block hydraulically operated attachments and loads before servicing. Do not rely on controls to support attachments or loads.

Stop the engine and relieve hydraulic pressure to zero before servicing or disconnecting any part of the hydraulic system. After stopping the engine, operate the controls in both directions to relieve pressure.

Before servicing the hydraulic system, attach a warning sign to the engine start controls to warn other personnel not to start the engine.

Do not perform hydraulic system maintenance, adjustment, or repair procedures unless authorized to do so. And then, make sure all applicable instructions have been read and are thoroughly understood.

Do not alter specified pressure settings. Higher than specified pressures can cause structural or hydraulic failure. Lower than specified pressures can cause loss of control.

Never check for hydraulic leaks with your hands. Pressurized oil can penetrate the skin, causing serious injury. Oil escaping from a small hole can be nearly invisible. Check for leaks with a piece of cardboard or wood.

Storing and Handling Oil

- Store oil drums in a clean, cool, dry location. **Avoid outdoor storage.**
- Store oil drums on their side and cover them to prevent water and dirt from collecting on them.
- When handling drums and transfer containers, use care to avoid damage which can cause leaks and entry of dirt or water into the oil.
- Before opening a drum, carefully clean the top of it. Also clean the faucet or pump to remove oil from the drum.
- Only use clean transfer containers.
- Do not take oil from storage until the oil is needed. If the oil cannot be used immediately, keep the transfer container tightly covered.

Storing and Handling Parts

- Store new parts (valves, pumps, motors, hoses, tubes) in a clean dry indoor location.
- Do not unpack parts or remove port plugs until the parts are needed.
- Once unpacked, carefully inspect each part for damage that may have occurred during shipping. Remove all shipping material from the ports of parts before installing them.
- Fittings, hoses, and tubes that are not equipped with shipping caps or plugs must be carefully cleaned before they are used. Flush the fittings, hoses, and tubes with clean hydraulic oil, then seal all openings until use at assembly.
- Do not use rags to plug openings, use clean plastic shipping plugs and caps.

Inspecting the Hydraulic System

The damaging effects of dirt, heat, air, and water in the hydraulic system can only be prevented by regular, thorough inspection of the system.

The frequency of inspection depends on operating conditions and experience with the system. However, the more often the system is inspected and deficiencies corrected, the less likely the system will malfunction.

A good inspection program will:

- Keep accurate records so future maintenance needs can be projected.
- Check hydraulic oil level daily when the oil is cold by looking at hydraulic tank display on the information screen in the cab.

NOTE The full levels given are for an assembled crane with the cylinders in their ready-to-work positions.

- **Full Cold Level**
(approximately 60°F (16°C)
Screen should read 90 to 94%.

Full Hot Level
(approximately 180°F (82°C)
Screen should read 100%.

Do not fill tank to 100%. Oil will flow out of the breather.

- If the oil level drops to 70%, a fault alarm sounds and the fault Hydraulic Fluid Low icon appears on the fault screen. **Fill the tank immediately.**
- Fill the tank by pumping oil through the power fill coupling with an owner supplied portable pump or by pouring oil into the manual fill tube (see [step 18 on page 2-29](#)).

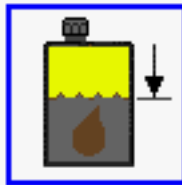

14COMT3-2-69

NOTE Do not fill the tank through the breather port. The hydraulic system could be contaminated from unfiltered oil.

Open the air valve to release pressure before filling through the manual fill tube.

- Only use approved hydraulic oil in the system. See Section 9 in this manual or the Lubrication Guide (Section 9).
- Replace the desiccant breather cartridge with a new one when all desiccant beads turn dark green (they are gold when new). See [Replacing Desiccant Breather Cartridge on page 2-24](#).
- Clean the exterior of system often. Do not let dirt accumulate on or around any part of system.

- Check for external leaks. Leaks are not only unsafe, they also attract dirt, and in some cases, allow air and water to enter system. Do not return leakage oil back to the hydraulic tank.

Do not to use your hands to check for leaks.

- Look for oil leaking from fittings and from between parts that are bolted together. Tighten loose fittings and attaching bolts to proper torque and do not over-tighten.
- If leakage persists at these points, replace the seals or gaskets.
- Look for oil leaking from pump and motor shaft ends, from valve spool ends, and from cylinder shaft ends. Replace seal if leakage is found at any of these points.
- Replace tubes that are cracked, kinked, or bent.
- Replace hoses that are cracked, split, or abraded.
- Listen to the pumps and motors for unusual noises. A high pitched whine or scream can indicate that air is being drawn into the pump or motor.

An air leak can be pinpointed by flooding the inlet fitting, hose, or tube with oil. If there is an air leak, the oil will cause a noticeable reduction in noise.

Correct the cause for any air leak, or the pump or motor will be ruined.

NOTE A high pitched whine or scream from a pump can also indicate cavitation (pump being starved of oil). This condition is caused by:

- Shutoff valve closed
- Collapsed or plugged suction line
- Wrong oil (viscosity too high)

- Look for signs of overheating: heat-peeled parts, burned and scorched oil odor, and darkening and thickening of oil. Maximum temperature of oil in the tank must not exceed 180°F (82°C).



HydraulicFluidTempFaultIcon

- If the oil temperature in tank rises above 180°F (82°C) or drops below 60° (16°C), a fault alarm sounds and the fault Hydraulic Fluid Temperature icon appears on the fault display.
- Have the hydraulic oil analyzed at regular intervals to determine the condition of the oil and the extent of system contamination. By having the oil analyzed on a regular basis, an oil change interval meeting your operating conditions can be established.

Contact your oil supplier for the availability of oil analysis services and the steps that should be taken to obtain these services.

Inspecting and Replacing Hydraulic Hoses

CAUTION

Hydraulic Component Damage

Do not alter hydraulic system specifications given in this section without approval of the Manitowoc Crane Care Lattice Team.

Damage to hydraulic components and improper operation of crane can occur if specifications are altered.



CAUTION

Burn Hazard

Oil in hydraulic tank may be under pressure and extremely hot.

Ensure that the hydraulic hose is de-pressurized before loosening any connections.

Periodic Inspection

Visually inspect all hydraulic hose assemblies every month or at 200 hours of service life for:

- Leaks at hose fittings or in hose
- Damaged, cut or abraded cover
- Exposed reinforcement
- Kinked, crushed, flattened or twisted hose
- Hard, stiff, heat cracked or charred hose
- Blistered, soft, degraded, or loose cover
- Cracked, damaged or badly corroded fittings

- Fitting slippage on hose
- Other signs of significant deterioration

If any of these conditions exist, evaluate the hose assemblies for correction or replacement.

At the same service interval, visually inspect all other hydraulic components and valves for:

- Leaking ports
- Leaking valve sections or manifolds and valves installed into cylinders or onto motors
- Damaged or missing hose clamps, guards, or shields
- Excessive dirt and debris around hose assemblies

If any of these conditions exist, address them appropriately.

Periodic Replacement

Hydraulic hose assemblies operating in **zone C** ([Table 2-2](#)) should be replaced after 8,000 hours of service life.

Hydraulic hose assemblies operating in **zones A and B** with high ambient temperatures and high duty circuits could see hose service life reduced by 40% to 50%. High duty circuits can include, but are not limited to hoist(s), boom lift, swing, travel, pump suction and discharge to directional valves and directional valve return to reservoir. Replace hoses operating in **zones A and B** after 4,000 to 5,000 hours of service life.

Hydraulic hose assemblies operating in **zone D and E**, should expect a degrade of mechanical properties and long term exposure to these cold temperatures will negatively impact service life. Cold temperatures shorten hose life, therefore frequent inspection is required.

Table 2-2 Climate Zone Classifications

| Zone | Description |
|------|---|
| A | Tropical Moist: All months average above 65° F (18° C). Latitude: 15° - 25° N & S |
| B | Dry or Arid: Deficient precipitation most of the year. Latitude: 20° - 35° N & S |
| C | Moist Mid-Latitude: Temperate with mild winters. Latitude: 30° - 50° N & S |
| D | Moist Mid-Latitude: Cold winters. Latitude 50° - 70° N & S |
| E | Polar: Extremely cold winters and summers. Latitude: 60° - 75° N & S |

Tightening Hydraulic Connections

- Make sure the fittings and O-rings being used are the proper size and style.
 - Flush sealing surfaces with clean hydraulic oil to remove any dirt.
 - Carefully inspect threads and sealing surfaces for nicks, gouges, and other damage. Do not use damaged parts; they will leak.
 - Carefully inspect O-rings for cuts and other damage. Do not use damaged O-rings: they will leak.
 - Always lubricate O-rings when assembling onto the fittings.
- Be careful not to cut O-rings when assembling them onto fittings. Use a thimble as shown in [Figure 2-18](#) when assembling O-ring over threads.

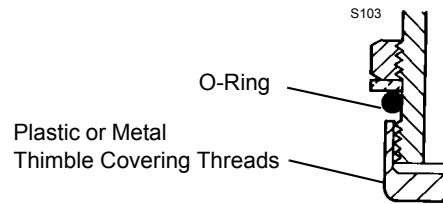

Figure 2-18. O-ring Assembly with Thimble

Pipe Thread Connection

1. Apply sealant (Loctite 92 or equivalent) to male threads, never to female threads. Do not apply sealant to the first two male threads.

CAUTION

Hydraulic System Damage

Do not use FTE-fluorocarbon tape to seal threads. Pieces of tape will enter the hydraulic system and cause damage.

2. Tighten the fittings about 4-1/2 turns by hand and then 3 additional turns with a wrench.

Table 2-3 Pipe Thread Connection Repair

| Causes | Cures |
|--|---------------------------------|
| Fitting loose | Tighten |
| Fitting too tight causing thread distortion | Replace damaged parts |
| Threads on fitting/port wrong size | Use proper size threads |
| Threads dirty, galled or nicked | Clean or replace parts |
| Straight thread used instead of tapered thread | Use proper type and size thread |
| Threads expanded from heat | Tighten when hot |
| Fitting loosened by vibration | Retighten |

SAE Straight-Thread Connection

This type connection leaks most often because the jam nut and washer are not backed up before assembly.

When the jam nut and washer are not backed up, there is not enough room for the O-ring when the squeeze takes place and the washer cannot seat properly as shown in [Figure 2-19](#), View A. The compressed rubber between the washer and the spot face will cold flow out of compression, causing the fitting to loosen and leak as shown in [Figure 2-19](#), View B.

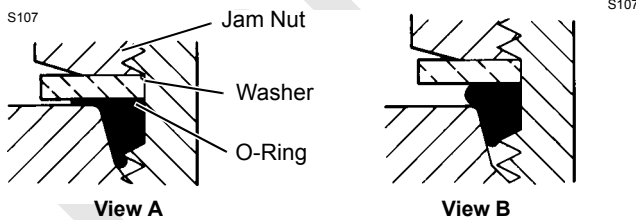

When jam nut and washer are not backed up, there is not enough room for O-ring when squeeze takes place.

Washer cannot seat properly on spot face. Compressed rubber between washer and spot face will cold flow out of compression, causing fitting to loosen and leak.

Figure 2-19. Incorrect SAE O-ring Seating

Tighten SAE straight thread connections as follows:

1. Back up the jam nut and washer to the end of the smooth portion on the fitting as shown in [Figure 2-20](#), View A.

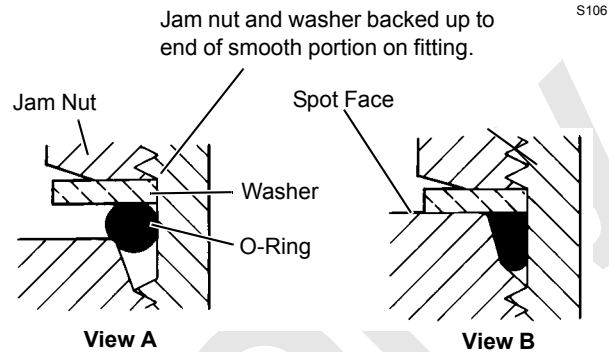

Figure 2-20. Correct SAE O-ring Seating

2. Lubricate the O-ring with clean oil. This is very important.
3. Thread the fitting into the port until the washer bottoms against the spot face as shown in [Figure 2-20](#), View B.

NOTE If an elbow is being used, back it out as necessary to align it with the hose.

4. Tighten the jam nut. When the fitting is properly installed, the O-ring will completely fill the seal cavity and the washer will be tight against the spot face as shown in [Figure 2-20](#), View B.

Table 2-4 Straight Thread Connection Repair

| Causes | Cures |
|--|---|
| Jam nut and washer not backed up at assembly, causing O-ring to be pinched | Replace O-ring and tighten fitting properly |
| O-ring cut | Replace |
| O-ring wrong size | Replace with proper size |
| Sealing surfaces gouged or scratched | Repair if possible or replace damaged parts |
| Sealing surfaces dirty | Clean and lubricate |

ORS Connection

NOTE ORS is the registered trade mark for a face-type seal manufactured by Aeroquip Corporation.

1. Lubricate and install the O-ring into the adapter groove (Figure 2-21).

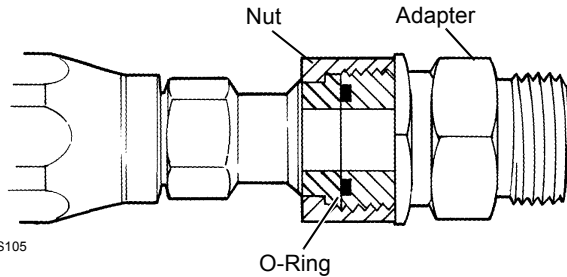

Figure 2-21. ORS Connection

2. Lubricate the threads.
3. Tighten the nut to the torque value given in Table 2-5.

Table 2-5 ORS Assembly Torque

| Nut Size Across Flats in (mm) | Fitting Size | Torque | |
|-------------------------------------|-----------------|-------------|-----------|
| | | In-Lb | Nm |
| 5/8 (15,9) | -04 | 120 – 145 | 14 – 16 |
| 13/16 (20,7) | -06 | 203 – 245 | 23 – 28 |
| 15/16 (23,8) | -08 | 380 – 470 | 43 – 53 |
| 1-1/8 (28,6) | -10 | 550 – 680 | 62 – 77 |
| 1-3/8 (34,9) | -12 | 763 – 945 | 86 – 107 |
| 1-5/8 (41,3) | -16 | 1110 – 1260 | 125 – 142 |
| 1-7/8 (47,6) | -20 | 1500 – 1680 | 170 – 190 |

Table 2-6 ORS Connection Repair

| Causes | Cures |
|--------------------------------------|---|
| Nut Loose | Tighten to proper torque |
| O-ring cut | Replace |
| O-ring wrong size | Replace with proper size |
| Sealing surfaces gouged or scratched | Repair if possible or replace damaged parts |
| Sealing surfaces dirty | Clean and lubricate |

Split Flange Connection

1. Lubricate and install the O-ring in the shoulder groove (see [Figure 2-22](#)). Align the shoulder with the port and assemble the flanges over the shoulder.

NOTE Bolts used must be grade-5 or better. A grade-5 bolt has three dashes in the head.

2. Snug the bolts in a diagonal manner ([Figure 2-22](#)) to 1/3 of the torque given in [Table 2-7](#).
3. Repeat [step 2](#) to 2/3 of the final torque. Repeat [step 2](#) to the final torque.

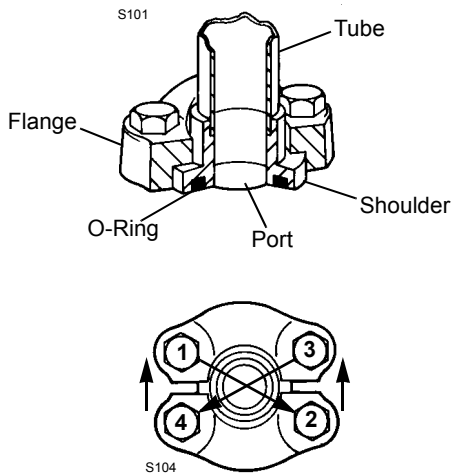

Figure 2-22. Split Flange Connection

Table 2-7 Split Flange Assembly Torque

| A Dimension inch (mm) | Flange Size | Torque | |
|---------------------------------|----------------|-----------|---------|
| | | in-lb | Nm |
| Standard Pressure Series | | | |
| 1-1/2 (38,1) | -08 | 175 – 225 | 20 – 25 |
| 1-7/8 (47,6) | -12 | 225 – 350 | 25 – 40 |

| A Dimension inch (mm) | Flange Size | Torque | |
|-----------------------------|----------------|-------------|-----------|
| | | in-lb | Nm |
| High Pressure Series | | | |
| 2-1/16 (52,4) | -16 | 325 – 425 | 37 – 48 |
| 2-15/16 (74,6) | -20 | 425 – 550 | 48 – 62 |
| 2-3/4 (69,9) | -24 | 550 – 700 | 62 – 79 |
| 3-1/16 (77,8) | -32 | 650 – 800 | 73 – 90 |
| 3-1/8 (79,4) | -24 | 1400 – 1600 | 158 – 181 |
| 3-13/16 (96,8) | -32 | 2400 – 2600 | 271 – 294 |
| 1-9/16 (39,7) | -08 | 175 – 225 | 20 – 25 |
| 2 (50,8) | -12 | 300 – 400 | 34 – 45 |
| 2-1/4 (57,2) | -16 | 500 – 600 | 57 – 68 |
| 2-5/8 (66,7) | -20 | 750 – 900 | 85 – 102 |
| 3-1/8 (79,4) | -24 | 1400 – 1600 | 158 – 181 |
| 3-13/16 (96,8) | -32 | 2400 – 2600 | 271 – 294 |

Table 2-8 Split Flange Connection Repair

| Causes | Cures |
|--|--|
| Flanges not tight | Tighten the bolts evenly to proper torque |
| Flanges tightened unevenly causing extrusion of the O-ring | Replace the O-rings. Tighten bolts evenly to proper torque |
| O-ring cut | Replace |
| O-ring the wrong size | Replace with the proper size |
| Sealing surfaces not smooth; scratched or gouged | Repair if possible or replace parts |
| Sealing surfaces dirty | Clean |
| Flanges keep getting loose in service | Use SAE grade 5 bolts or better. Retighten the bolts after system is hot |

SAE Flare Connection

1. Tighten the nut finger-tight until the sealing surfaces touch.
2. Mark a line (use felt pen or marker) on the adapter and extend it onto the connector nut (Figure 2-23, View A).
3. Using wrenches, tighten the connector nut the number of flats shown in Table 2-9.

4. Misalignment of the marks will show how much the nut has been tightened, and best of all that it has been tightened.

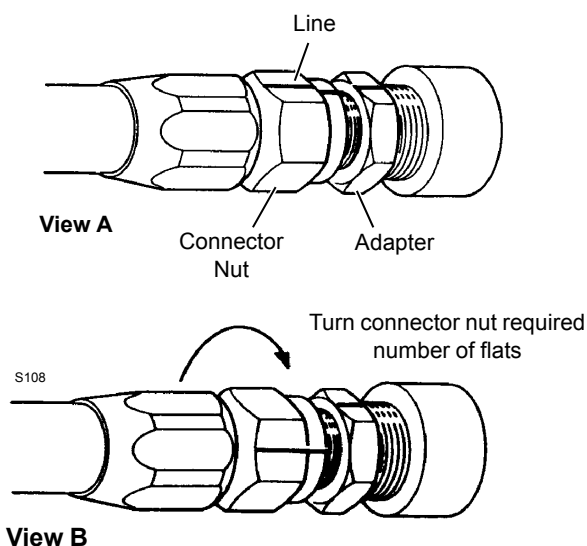

Figure 2-23. SAE Flare Connection

Table 2-9 SAE 37° Flare Tightening

| Connector Nut Size Across Flats - inch (mm) | Fitting Size | Adapter Flats to Rotate |
|--|-----------------|----------------------------|
| 9/16 (14,3) | -04 | 2-1/2 |
| 5/8 (15,9) | -05 | 2-1/2 |
| 11/16 (17,5) | -06 | 2 |
| 7/8 (22,2) | -08 | 2 |
| 1 (24,5) | -10 | 1-1/2 – 2 |
| 1-1/4 (31,8) | -12 | 1 |
| 1-1/2 (38,1) | -16 | 3/4 – 1 |
| 2 (50,8) | -20 | 3/4 – 1 |
| 2-1/4 (57,2) | -24 | 1/2 – 3/4 |

Table 2-10 SAE 37° Flare Connection Repair

| Causes | Cures |
|---|--------------------------|
| Joint loose | Tighten properly |
| Sealing surfaces dirty | Clean |
| Sealing surfaces not smooth (scratched or gouged) | Replace the faulty parts |
| Sealing surfaces cracked | Replace the faulty parts |
| SAE 45° parts used with SAE 37° parts | Use only SAE 37° parts |

Left-Side Enclosure

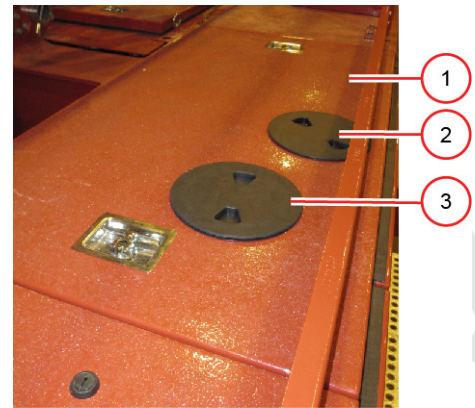

M102168

| Item | Description | Item | Description |
|------|-------------------------------|------|-------------------|
| 1 | Cover | 6 | Hydraulic Tank |
| 2 | Fill Plug Access Cover | 7 | Return Filter (3) |
| 3 | Breather Access Cover | 7a | Filter Cap |
| 4 | Air Vent Valves (2) | 7b | Filter Body |
| 5a | Breather Cartridge | 7c | Filter Element |
| 5b | Reusable Cap (do not discard) | 7d | O-Rings |

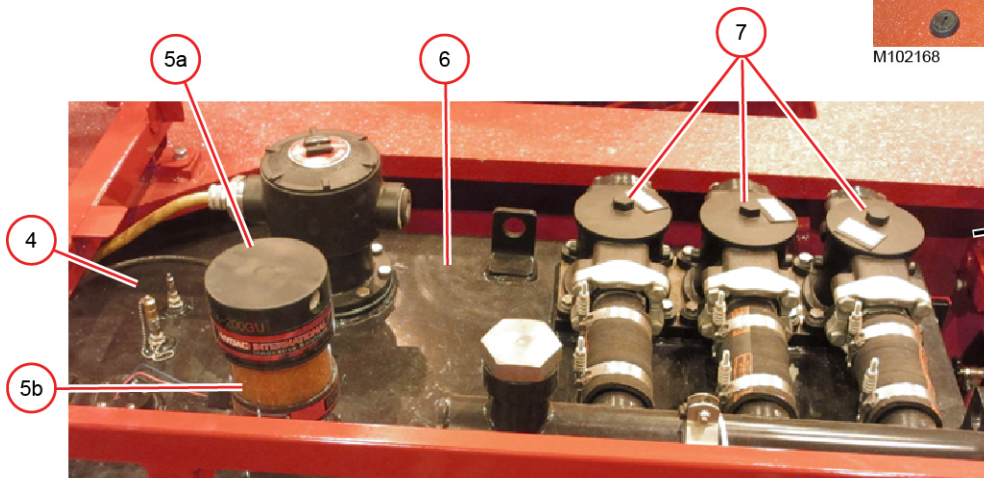

M102129a

Shown with Cover (1) Removed

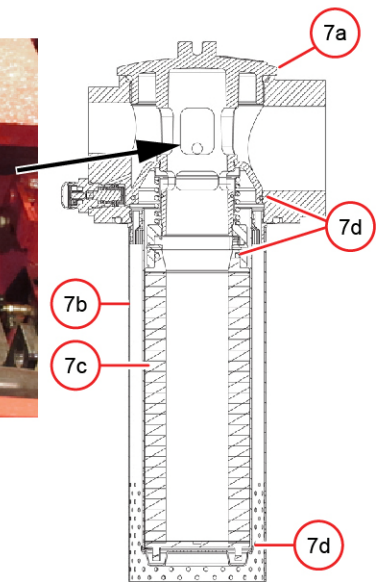

Figure 2-24. Hydraulic Tank

WARNING
Burn Hazard

Oil in hydraulic tank may be under pressure and extremely hot. Allow the hydraulic oil to cool before replacing the desiccant breather cartridge.

Hot oil can escape when removing the breather. Relieve pressure at the air vent valve (4, [Figure 2-24](#)) in the top of the tank before servicing the breather.

Replacing Desiccant Breather Cartridge

See [Figure 2-24](#) for this procedure.

1. Stop the engine.
2. Vent the pressure from the hydraulic tank (6) using either air vent valve (4).

3. Remove the breather access cover (3).
4. Unscrew the breather from the hydraulic tank (6).
5. Unscrew the reusable cap (5a) from the breather cartridge (5b) and dispose of the used breather cartridge properly. Do not discard the cap.
6. Remove protective caps from top and bottom of new cartridge.
7. Securely attach the reusable cap (5a) to the cartridge (5b). **Hand tighten only.**
8. Securely attach the breather to the hydraulic tank (6). **Hand tighten only.**
9. Start the engine and allow the hydraulic system to reach it's normal operating temperature.
10. Check the breather for leaks and service as required.

**WARNING****Burn Hazard**

Oil in hydraulic tank may be under pressure and extremely hot. Allow the hydraulic oil to cool before replacing the return filter elements.

Hot oil can escape when removing the filter caps. Relieve pressure at the air vent valve (4, [Figure 2-24](#)) in the top of the tank before servicing the return filters.

CAUTION**Avoid Hydraulic System Damage**

Original Equipment Manufacturers' filter elements—available from Manitowoc—must be used on this crane. Substituting with any other brand or type filter element is not allowed.

Filter elements made by other manufacturers may collapse under pressure. This action will allow unfiltered oil to be drawn into hydraulic system—pumps, motors, and valves can be destroyed.

Manitowoc will reject warranty claims for damaged hydraulic components if proper hydraulic filter elements are not used.

Do not attempt to clean or reuse elements.

Do not operate crane without filter elements installed.

Replacing Return Filters

See [Figure 2-24](#) for this procedure.

This crane has three return filters (7) that filter all oil returning to the hydraulic tank (6).

If a return filter is dirty, a fault alarm comes on and a fault symbol appears on the active display. The Hydraulic Filter icon and corresponding filter number 1 appears on the fault display.

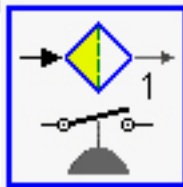

M100928

Replace all three return filter elements if the fault appears and at each oil change interval.

NOTE It is normal for the alert to come on at start-up when the oil is cold. If the filter is not plugged, alert will turn off after hydraulic oil warms up.

1. Stop the engine.
2. Remove the cover (1).
3. Vent the pressure from the hydraulic tank (6) using either air vent valve (5).
4. Clean the outsides of the three filter heads in the areas around filter caps (7a).
5. Replace each element as follows:
 - a. Remove the filter cap (7a) using the hexagon stud. **Use care not to damage O-rings.**
 - b. Twist and pull the filter elements (7c) to remove it from the filter body (7b).
 - c. Lubricate the O-ring (7d) at both ends of the new element (7c) with clean hydraulic oil and install the new element over the stem in the filter body (7b).
 - d. If necessary, replace any damaged O-rings in the filter cap (7a).
 - e. Lubricate the O-ring in the filter cap with clean hydraulic oil.
 - f. Install the filter cap (7a) onto the filter housing (7b) and securely tighten.
6. Start the engine and allow the hydraulic system to reach its normal operating temperature.
7. Check the filter caps and return lines for leaks and service as required.
8. Stop the engine.
9. Check the hydraulic tank level and fill as required (see [step 19 on page 2-29](#)).

| Item | Description |
|------|------------------|
| 1 | Filter Bowl |
| 2 | Filter Element |
| 3 | Manifold Adapter |

100854

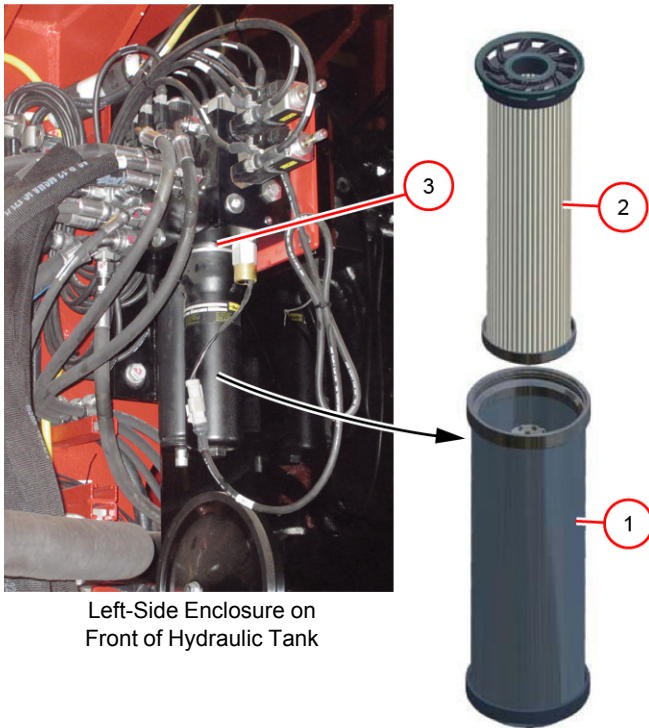

Left-Side Enclosure on Front of Hydraulic Tank

Figure 2-25. Pilot Filter

Replacing Pilot Filter

See [Figure 2-25](#) for this procedure.

If the pilot filter is dirty, a fault alarm comes on and a fault symbol appears on active the display. The Hydraulic Filter icon and corresponding filter number 2 appears on the fault display.

Replace the pilot filter element if the fault appears and at each oil change interval.

NOTE It is normal for the alert to come on at start-up when the oil is cold. If the filter is not plugged, alert will turn off after hydraulic oil warms up.

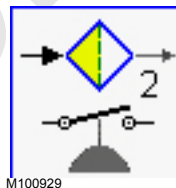

WARNING

Burn Hazard

Oil in the pilot system may be extremely hot. Allow the hydraulic oil to cool before replacing the pilot filter.

CAUTION

Avoid Hydraulic System Damage

Original equipment manufacturers' filter elements—available from Manitowoc—must be used on this crane. Substituting with any other brand or type of filter element is not allowed.

Filter elements made by other manufacturers may collapse under pressure. This action will allow unfiltered oil to be drawn into the hydraulic system—pumps, motors, and valves can be destroyed.

Manitowoc will reject warranty claims for damaged hydraulic components if the proper hydraulic filter elements are not used.

Do not attempt to clean or reuse the elements.

Do not operate the crane without filter elements installed.

To replace the pilot filter element:

1. Stop the engine.
2. Remove the filter bowl (1) by rotating it counter-clockwise.
3. Remove the used filter element (2) from the manifold adapter (3) and dispose of it properly.
4. Lubricate the filter bowl (1) and manifold adapter (3) threads with clean hydraulic oil.
5. Lubricate all filter element (2) seals with clean hydraulic oil.
6. Install the filter element (2) onto the manifold adapter (3).
7. Install the filter bowl (1) onto the manifold adapter (3) by rotating it clockwise and tightening to 35-40 ft-lb (48-54 Nm).
8. Start the engine and allow the hydraulic system to reach its normal operating temperature.
9. Check the pilot filter for leaks and service as required.

| Item | Description |
|------|-----------------------|
| 1 | Visual Indicator |
| 2 | Swing Pump FA Port |
| 3 | Filter Bowl |
| 4 | Filter Element |
| 5 | Filter Element O-Ring |

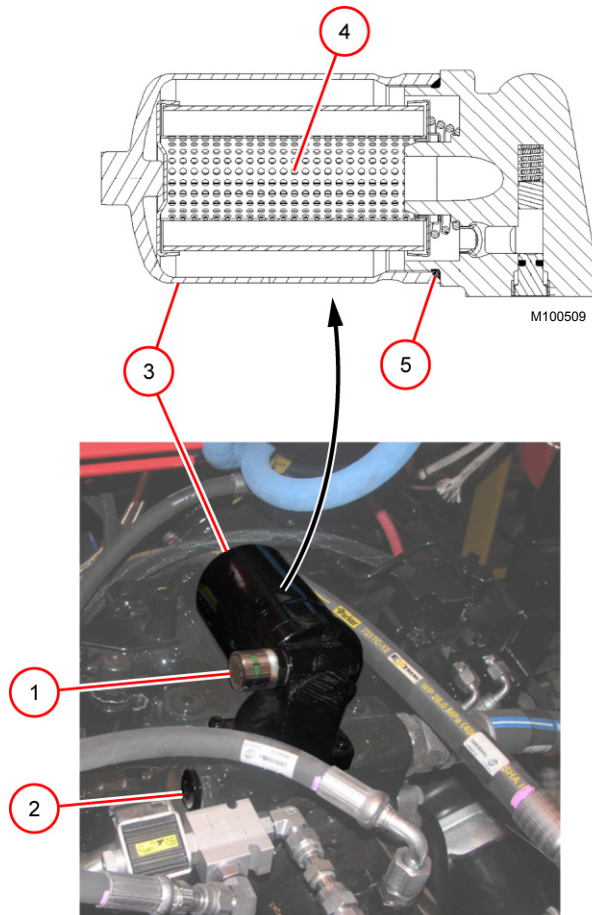

Figure 2-26. Swing Filter

Replacing the Swing Filter

See [Figure 2-26](#) for this procedure.

Replace the swing filter element (on top of swing pump) if the visual indicator (1) turns from green to red and at each oil change interval.

WARNING Burn Hazard

Oil in the swing pump may be extremely hot. Allow the hydraulic oil to cool before replacing the swing filter.

CAUTION

Avoid Hydraulic System Damage

Original Equipment Manufacturers' filter elements—available from Manitowoc—must be used on this crane. Substituting with any other brand or type filter element is not allowed.

Filter elements made by other manufacturers may collapse under pressure. This action will allow unfiltered oil to be drawn into hydraulic system—pumps, motors, and valves can be destroyed.

Manitowoc will reject warranty claims for damaged hydraulic components if proper hydraulic filter elements are not used.

Do not attempt to clean or reuse elements.

Do not operate crane without filter elements installed.

To replace the swing filter:

1. Stop the engine.
2. Close the hydraulic tank shutoff valve.
3. Remove the swing pump FA port plug (2) to drain the oil from the swing filter into a suitable container.
4. Reinstall the swing pump FA port plug.
5. Remove the filter bowl (3) by rotating it counter-clockwise.
6. Remove the used filter element and dispose of it properly.
7. Lubricate the filter bowl threads using clean hydraulic oil.
8. Inspect and lubricate the new filter element O-ring (5) using clean hydraulic oil.
9. Install the filter element onto the filter head.
10. Install the filter bowl onto the filter head by rotating it clockwise and tightening.
11. Start the engine and allow it to idle for five minutes to allow the charge pump to fill the filter and purge air before swinging.
12. Run the swing hydraulic system and check for leaks. Service as required.

| Item | Description | Item | Description |
|------|----------------------------------|------|--|
| 1 | Cover | 8 | Drain Pipe |
| 2 | Air Vent Valves (2) | 9 | Locking Pin (pull out to turn handle) |
| 3 | Breather (see NOTE) | 10 | Shut-off Handle |
| 4 | Manual Fill Port Plug (see NOTE) | 10a | Closed Position |
| 5 | Return Filters (3) | 10b | Opened Position |
| 6 | Power-Fill Coupling | 11 | Oil Level Gauge with Temperature Gauge |
| 7 | Drain Valve Handle | 12 | Access Cover |
| 7a | Closed Position | 13 | Suction Filter (Accessible under threaded cover) |
| 7b | Opened Position | | |

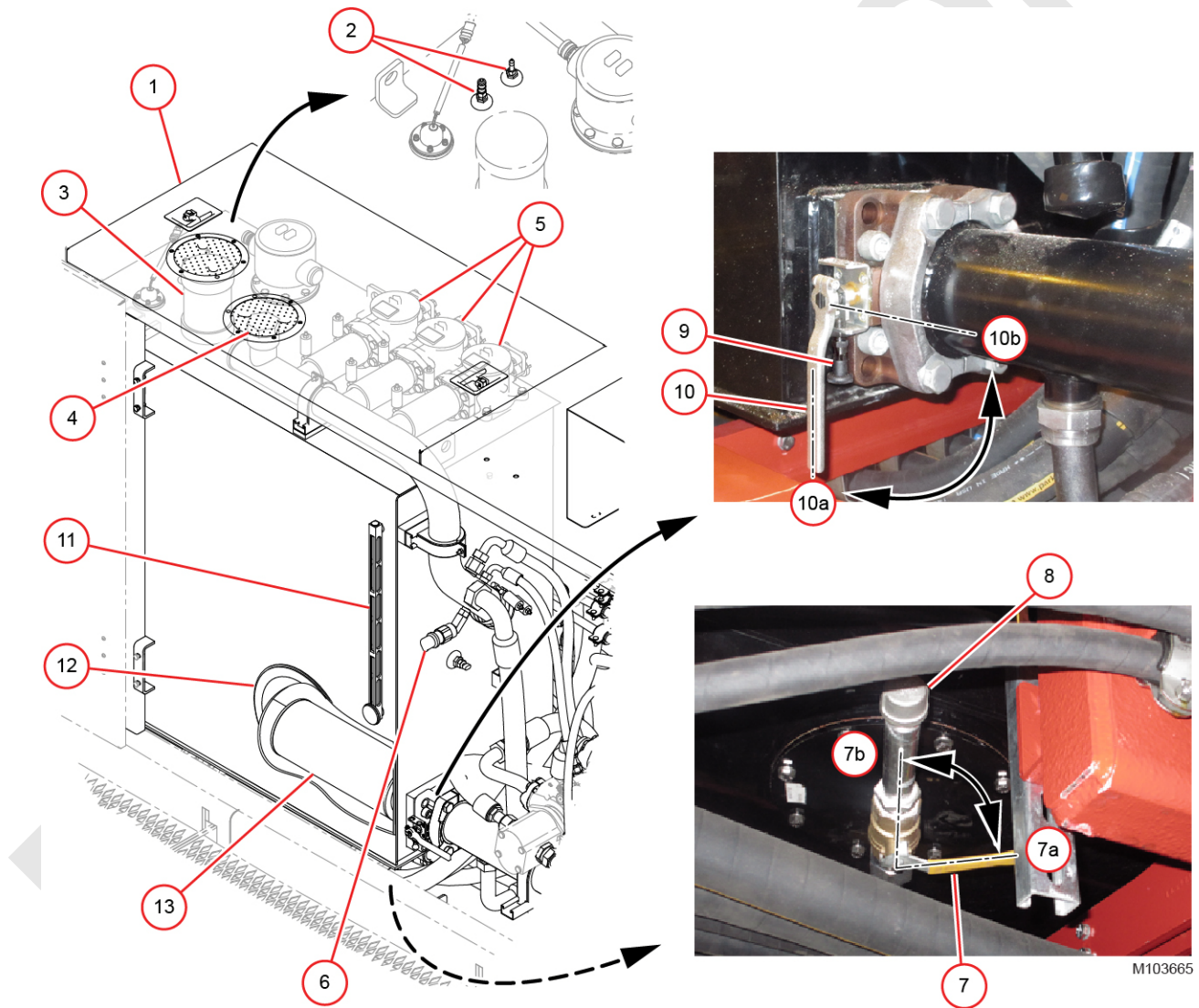

Figure 2-27. Hydraulic Tank

Changing the Hydraulic Oil

Drain and refill the hydraulic system every 1,000 hours or semiannually, whichever comes first, unless an alternate interval has been established through an oil analysis program.

See [Figure 2-27](#) for the following procedure.

1. Operate the crane until the hydraulic oil is at its normal operating temperature. This will help prevent impurities from settling in the system.
2. Stop the engine.
3. Remove cover (1) and place it to the side.



WARNING

Burn Hazard

Hot oil can escape when removing the breather (3), the manual fill port plug (4), or the return filter covers (5). Relieve pressure at either air vent valve (2) in the top of the tank before servicing the hydraulic tank.

4. Open either air vent valve (2) to allow air to enter and escape from the hydraulic tank when draining and filling.
5. Attach a hose to the drain pipe (8) and insert the free end of the hose into a suitable container to catch the hydraulic oil. See the MLC165-1 Lubrication Guide for the hydraulic system capacity.
6. Verify the hydraulic tank shut-off handle (10) is in the opened position (10b).
7. Move the drain valve handle (7) to the opened position (7b) and drain the tank completely.
8. Remove the access cover (12) from the tank. **Take care to prevent dust and wind-blown dirt from entering tank while the access covers are off.**
9. Clean out any sediment inside of the tank.
10. Carefully inspect the suction filter (13) for damaged or clogged holes and for sludge, gum, or lacquer formation. If necessary, clean the suction filter:
 - a. Using a wrench, remove suction filter from inside of the tank.
 - b. Soak the suction filter in clean, nonflammable solvent. Brush off the outer surface of the suction filter and flush it from the inside out. Discard if damaged.
 - c. Securely reinstall the suction filter.
11. Using new seals, securely fasten the access cover to the tank.

12. Replace the breather (3) desiccant cartridge. See [Replacing Desiccant Breather Cartridge on page 2-24](#).
13. Replace the three return filter elements (5). See [Replacing Return Filters on page 2-25](#).
14. Replace the pilot manifold filter. See [Replacing Pilot Filter on page 2-26](#).
15. Replace the swing filter. See [Replacing the Swing Filter on page 2-27](#).
16. Move the drain valve handle (7) to the closed (7a) position.
17. Remove the hose from the drain pipe and reinstall the cap on the pipe.

CAUTION

Contamination Hazard

Do not fill hydraulic tank through breather opening or through top of return filter(s). Harmful contaminants will enter hydraulic system. Damage to pumps and motors can occur.

18. The hydraulic tank can be filled through the power-fill coupling (6) with an owner supplied pump or through the manual fill port (4).
19. Fill the tank to the Full Cold Level symbol next to the oil level gauge (11).



The hydraulic tank display on the information screen in the cab should read 90 to 94%.

Use proper hydraulic oil. See the Lubrication Guide (Section 9 in this manual).

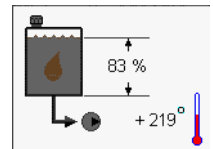

Do not fill the tank to 100%. Oil will flow out of the breather.

20. Close the air vent valves (2).
 21. Start the engine and allow the hydraulic system to rise to normal operating temperature.
 22. Check for leaks and correct them as required.
 23. Stop the engine.
 24. Check the tank level, and fill as required.
- NOTE** If the hydraulic system was extremely dirty (gum or lacquer formation on parts indicated by erratic, jerky, or sluggish operation) repeat this Changing the Hydraulic Oil procedure after 48 hours of operation.
25. Reinstall the cover (1).

Servicing the Pumps

It is not necessary to drain the hydraulic tank when servicing the hydraulic pumps. To service the pumps, move the hydraulic tank shut-off handle (10) [Figure 2-27 on page 2-28](#) to the closed position (10a).

CAUTION

Avoid Damage to Pumps

Open the hydraulic tank shut-off valve before starting the engine. Failing to perform this step will result in damage to the pumps from cavitation.

Move the hydraulic tank supply shut-off handle to the open position (12) after servicing the pumps and before starting the engine.

Replacing a Pressure Transducer



WARNING

High Pressure Oil Hazard

Do not attempt to remove a pressure transducer unless following steps are performed. High pressure oil will exhaust from pressure transducer ports.

Before replacing a pressure transducer perform the following test steps and replace the transducer only if any of the test steps fail:

1. Perform the Pressure Transducer Test ([Pressure Transducer Test on page 2-33](#)).
2. Attach a hydraulic pressure gauge to the suspect pressure transducer.
3. If the gauge reads pressure greater than 0 psi (0 bar), bleed the corresponding system until the gauge reads 0 psi (0 bar).
4. Repeat the Pressure Transducer Test.
5. Verify the signal voltage at the transducer is 0.96 to 1.04Vdc referenced to ground at 0 psi (0 bar).
6. Start the engine and run it at idle.



WARNING

Crush Hazard

When actuating a hydraulic function to read a pilot pressure with a gauge, the associated parts will move when the function is actuated. Keep all personnel clear of the parts that will move during the test.

7. If testing a pilot pressure, actuate the function for the pressure being read.
8. Verify the gauge pressure and the pressure displayed at the Pressure Transducer Test screen are within the limits of [Table 2-11](#).

Table 2-11 Transducer/Gauge Pressure Agreement

| Pressure Type | Pressure |
|---------------|----------------------|
| Pilot | +/- 20psi (1.4 bar) |
| System | +/- 50 psi (3.4 bar) |

To replace a pressure transducer:

1. Lower all loads to the ground.
2. Move all control handles to off and park all crane functions.
3. Shut off the engine.
4. Place a suitable container under the faulty pressure transducers to catch the draining oil.
5. Disconnect the electrical connector from the pressure transducer.
6. **Slowly loosen** the pressure transducer only enough to relieve pressure.
7. Remove the pressure transducer.
8. Install the new pressure transducer and connect the electrical connector.
9. Bleed the pressure transducer circuit:
 - a. Connect a bleed line with a shut-off valve to the coupler on the pressure transducer manifold and place the end of the hose into a suitable container.
 - b. Open the shut-off valve.
 - c. With all control handles off, start and run engine at low idle.
 - d. When clear oil flows from bleed lines (no air bubbles in oil), close the shut-off valve.
 - e. Shut off the engine.
 - f. Remove the bleed line from coupler at the pressure transducer.
10. Perform the Pressure Transducer Test ([Pressure Transducer Test on page 2-33](#)).

HYDRAULIC TESTS AND CALIBRATIONS

Experienced technicians, trained in the operation of this crane and its hydraulic system, shall perform the procedures described in this section. The technicians shall read, understand, and comply with the instructions in this section and to the display screen instructions in the MLC165-1 Main Display Operation manual.

Contact your Manitowoc dealer for an explanation of any procedure not fully understood.

The calibration, and test procedures described in this section were made to the crane before it was shipped from the factory. These procedures must be performed by field personnel only when parts are replaced or when instructed by a Manitowoc dealer.

Travel Speed Test

NOTE Perform this check in an area where the crane can be traveled without interference.

An assistant is needed to count the rotations of the crawler rollers.

1. Apply a timing mark (1, [Figure 2-28](#)) mark to the outside of one front crawler roller (2) and to the same location on the inside of the other front crawler roller so the assistant can see both timing marks.
2. Start the engine and run it at high idle.
3. Using the travel speed selection switch, select high speed travel.
4. Travel the crane forward at full speed for one minute while the assistant walks along side the crane and counts the timing mark revolutions.

5. Verify the counted revolutions are within the limits specified in [Table 2-1 on page 2-15](#). If the counted rotations are not within the specified range, contact the Manitowoc Crane Care Lattice Team.
6. Travel the crane in reverse at full speed for one minute while the assistant walks along side the crane and counts the timing mark revolutions.
7. Verify the counted revolutions are within the limits specified in [Table 2-1 on page 2-15](#). If the counted rotations are not within the specified range, contact the Manitowoc Crane Care Lattice Team.

| Item | Description |
|------|----------------------|
| 1 | Timing Marks |
| 2 | Front Crawler Roller |

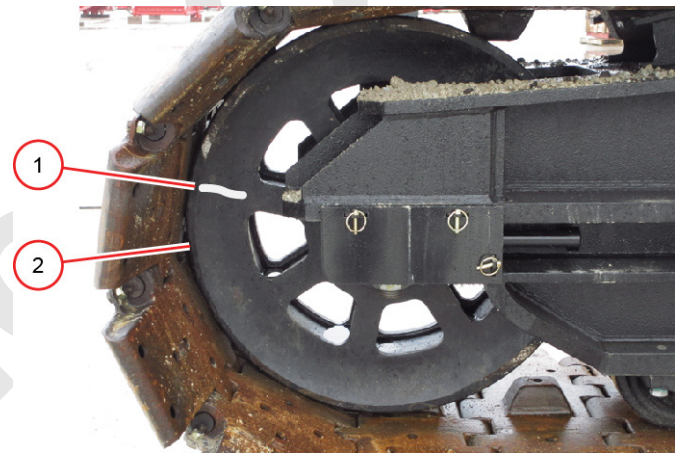

M103667

Figure 2-28. Crawler Timing Marks

Swing Speed Test

NOTE Perform this check in an area where crane can be swung without interference.

1. At the main display, navigate to the Swing Diagnostic screen (Figure 2-29 on page 2-32).

M100926

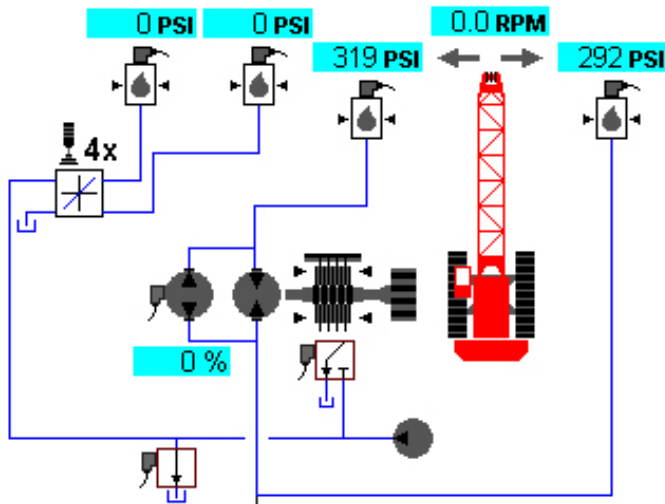

Figure 2-29. Swing Diagnostic Screen

2. Start engine and run at high idle.
3. Move the swing handle fully left.
4. At the Swing Diagnostic screen, verify the swing speed is within the limits of [Table 2-1 on page 2-15](#).
5. Return the swing handle to the center and allow the rotating bed to come to a stop.
6. Move the swing handle fully right.
7. At the Swing Diagnostic screen, verify the swing speed is within the limits of [Table 2-1 on page 2-15](#).
8. Return the swing handle to the center and allow the rotating bed to come to a stop.
9. Shut off the engine.

Pressure Transducer Test

The pressure transducer test calculates the zero-pressure output level for each pressure transducer. It is only necessary to perform this procedure at the specified intervals or when necessary during troubleshooting.

Perform this test whenever:

- A new pressure transducer is installed.
- A new universal node that monitors pressure transducers is installed.
- A new master node or master node software is installed.
- Pressure readings are in error.

NOTE Be aware that if there is any residual pressure in the system during the calibration process, the display pressure reading in the cab may not reflect actual system pressure

To test the pressure transducers:

1. Stop engine and turn ignition switch to the run position.
2. At the display, navigate to test screen 1 or 2 and run the pressure transducer test (Figure 2-30).

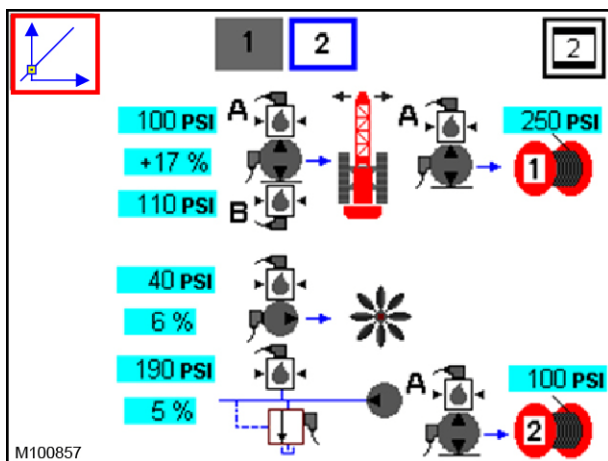

Figure 2-30. Test Screen 1

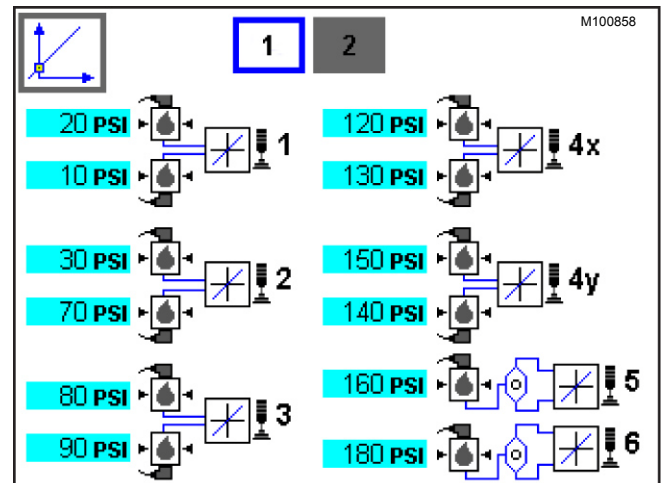

Figure 2-31. Test Screen 2

3. When the pressure transducer test completes, verify no pressure transducer icons are highlighted in yellow in either test screen. If any pressure transducer icons appear in yellow, troubleshoot the corresponding transducers to determine the fault cause.

NOTE The cause of a failed pressure transducer test or faulty display pressure reading may not be the pressure transducer. The cause of the fault could be trapped air or hydraulic pressure in the system during the pressure transducer test.

Controls Calibration

A controls calibration calculates the pump threshold command level for the swing and accessory pump controls.

Perform this calibration when:

- A new swing pump, motor, or control coil is installed.
- A new accessory pump or control coil is installed.
- A new master node or master node software is installed.
- Operation indicates threshold is in error:
 - Excessive handle motion or time is required to initiate swing motion.
 - Inability to start swing motion smoothly.

To perform the controls calibration:

1. Apply all park brakes using the switches on the control console.
2. Start and run engine at high idle.
3. At the display, navigate to test screen 1 or and run the calibration test (Figure 2-30 on page 2-33).

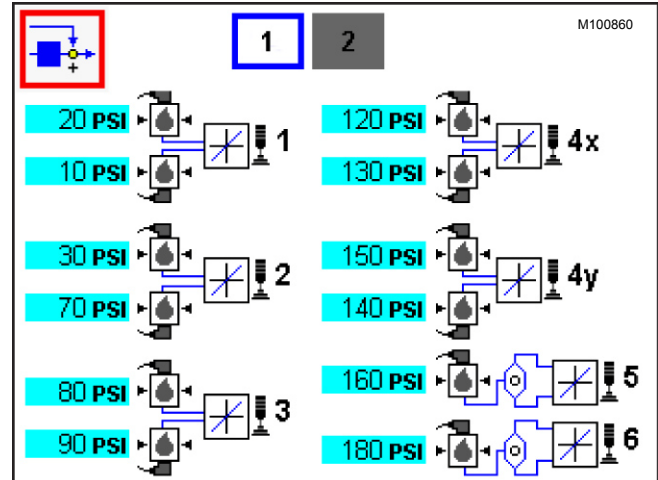

Figure 2-33. Test Screen 2

4. Verify no icons are highlighted in yellow in either test screen. Troubleshoot failed circuits to determine the fault cause.
5. Verify no pumps are highlighted in yellow. Troubleshoot failed circuits to determine the fault cause.

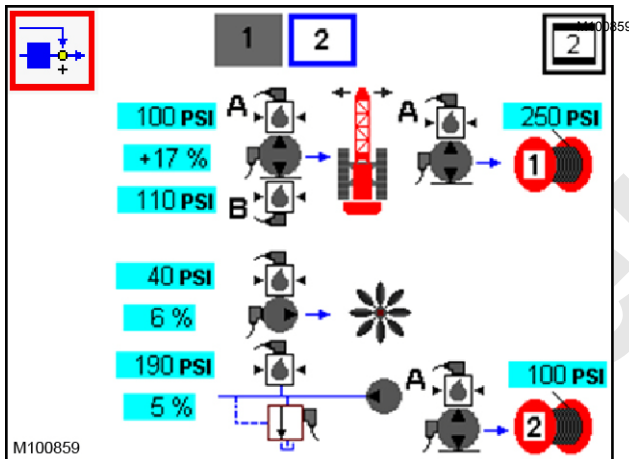

Figure 2-32. Test Screen 1

Drum Brake Test

Perform an operational test of each brake weekly.

NOTE See [Table 2-1 on page 2-15](#) for system pressure specifications.

The electrical connector must be disconnected at the brake solenoid valves to stall the crane functions during the test.

1. At the pilot brake and pawl manifold ([Figure 2-13 on page 2-10](#)), disconnect the electrical connector from the solenoid for the brake being checked.
2. Start and run the engine at low idle.
3. Turn off the park switch on the control console for the function being checked.
4. At the display, navigate to the diagnostic screen for function being checked (See the MLC165-1 Main Display Operation manual for display navigation instructions).

CAUTION

Overheating Hazard

Do not stall any function for more than 5 seconds. Damage from overheating can occur to the system components.



WARNING

Falling Load/Moving Crane Hazard

If a disc brake slips when the drum brake test is performed, repair or replace it before placing crane back into service. Loads could fall or the crane could move if the brakes are not operating properly.

See the corresponding motor or gearbox manufacturer's manual for disc brake repair instructions.

NOTE For the front or rear load drum, make sure *free fall* is off.

Monitor the system pressure and pump command while moving the control handle.

5. Slowly move the control handle the for function being checked and verify:
 - Specified system pressure is reached before 50% pump command is reached.
 - Brake does not slip.

If the brake fails to meet these criteria, it must be repaired or replaced and retested before operating with a load.

6. Turn on the park switch on the control console for the function being checked.

7. Shut off the engine.

8. At the pilot brake and pawl manifold, reconnect the electrical connector to the solenoid of the brake that was checked.

Swing Brake Test

Perform an operational test of the swing brake weekly in an area where the crane be swung without interference.

NOTE See [Table 2-1 on page 2-15](#) for system pressure specifications.

1. Start and run the engine at low idle.
2. Turn off the swing park switch.
3. At the display, navigate to the swing diagnostics screen and verify the swing park brake is released.
4. Swing the crane by moving control handle in both directions and verify the rotating bed swings freely.
5. Move the control handle to the neutral position and allow the rotating bed to come to a complete stop.
6. Turn on the swing park switch.
7. At the display, verify the swing park brake is applied.

CAUTION

Overheating Hazard

Do not stall any function for more than 5 seconds. Damage from overheating can occur to the system components.



WARNING

Moving Crane Hazard

If a disc brake slips when the swing brake test is performed, repair or replace it before placing crane back into service. The crane could move if the brakes are not operating properly.

See the corresponding motor or gearbox manufacturer's manual for disc brake repair instructions.

8. Attempt to swing the crane by moving control handle in both directions and verify:
 - Specified system pressure is reached before 50% pump command is reached.
 - Swing brake does not slip.

If the brake fails to meet these criteria, it must be repaired or replaced and retested before operating with a load.

9. Shut off the engine.

THIS PAGE INTENTIONALLY LEFT BLANK

SECTION 3 ELECTRICAL SYSTEM

TABLE OF CONTENTS

| | |
|---|------|
| Drum Identification | 3-1 |
| Electrical Power Sequence | 3-1 |
| Engine Bus Power | 3-1 |
| Cab Bus Power | 3-1 |
| CAN Bus Power | 3-1 |
| CAN Bus Control System | 3-1 |
| Master Node (Node 1) | 3-2 |
| Engine Node (Node 0) | 3-3 |
| Side Console Node (Node 2) | 3-3 |
| Universal Nodes (Nodes 3–5) | 3-3 |
| Pressure Transducers | 3-3 |
| Motor Speed Sensors | 3-4 |
| Drum Free Fall Sensors | 3-4 |
| Limit Switches — Single Contact | 3-4 |
| Limit Switches — Dual Contact | 3-4 |
| Solenoids | 3-4 |
| Mast Angle Sensors | 3-5 |
| Swing/Travel Alarms | 3-5 |
| Load Pin Sensors | 3-5 |
| Temperature Sensors | 3-5 |
| Fuel Level Sensor | 3-5 |
| Hydraulic Fluid Level Sensor | 3-5 |
| Pressure and Vacuum Switches | 3-5 |
| Setup Remote | 3-5 |
| Graphic Nodes | 3-6 |
| Wind Speed Remote Input Node | 3-6 |
| Boom and Luffing Jib Remote Input Nodes | 3-6 |
| Solenoid Valve Identification | 3-7 |
| Circuit Breakers | 3-8 |
| Alternator Circuit | 3-8 |
| Engine Node | 3-8 |
| operator cab | 3-9 |
| Grid Heater | 3-9 |
| Exhaust Aftertreatment System | 3-10 |
| 240 VAC Electric System | 3-10 |
| Checking and Replacing Electrical Components | 3-11 |
| Node Locations | 3-13 |
| Component to Node Identification | 3-13 |
| Pump and Motor Voltages and Currents | 3-14 |
| Abbreviations | 3-14 |
| Checking Electrical Inputs/Outputs (Using the Test Box) | 3-15 |
| Checking Electrical Inputs/Outputs (Using the Test Board) | 3-16 |
| Test Voltages | 3-17 |
| Node Heading Descriptions | 3-17 |
| Node 1 — Master | 3-18 |
| Node 2 — Alarms, Switches, and Gauge Panel | 3-20 |
| Node 3 — Drum Control and Limit Switches | 3-22 |
| Node 4 — Swing Control, Drum Brake and Pawl Control | 3-25 |
| Node 5 — Accessories | 3-27 |
| Boom Remote Input Node 30 | 3-30 |
| Luffing Jib Remote Input Node 31 | 3-31 |
| Node 0 — Engine | 3-32 |

THIS PAGE INTENTIONALLY LEFT BLANK

SECTION 3

ELECTRICAL SYSTEM

DRUM IDENTIFICATION

The drum numbers given in [Figure 3-1](#) are used to identify the drums in this section.

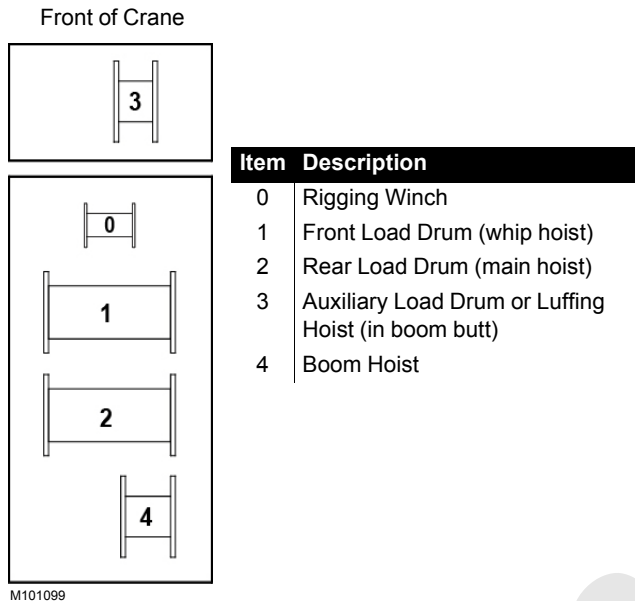

Figure 3-1. Drum Identification

ELECTRICAL POWER SEQUENCE

Engine Bus Power

The batteries provide power through the battery disconnect switch. When the switch is open, battery power is only available to the grid heater. When the switch is closed, battery power becomes available to the circuits powered by the engine bus:

- Engine start and run switch
- Starter solenoid
- Engine Electronic Control Module (ECM)
- A/C circuit
- Horns
- Dome light

Cab Bus Power

With the battery switch closed and engine bus power available, placing the ignition switch in the run position closes the cab power relay in node 0, providing power to the circuits on the cab bus:

- A/C and heater
- Wiper motors
- Panel lights
- Work lights
- Monitor
- Overhead console
- Engine Node 0

A DC to DC converter on the cab bus converts the 24Vdc cab bus voltage to 12Vdc for use by boom power and the radio.

CAN Bus Power

Engine Node 0 receives power from the cab bus and passes that power to the controller area network bus (CAN Bus) relay in node 0. The CAN Bus relay closes, providing power to the remaining CAN Bus nodes, as well as the boom and luffing jib remote input nodes (RIN).

CAN BUS CONTROL SYSTEM

CAN is a multi-master broadcast serial bus standard for connecting nodes. Each node is able to send and receive messages, but not simultaneously. A message consists primarily of an ID, which represents the priority of the message, and up to eight data bytes. It is transmitted serially onto a two wire differential bus.

CAN uses priority based bus arbitration. If the bus is free, any node may begin to transmit. If two or more nodes begin sending messages at the same time, the message with the higher priority ID sends its message, which is received by all nodes.

A transceiver within each node translates voltage and current levels between the microprocessor and the differential bus. When receiving, it converts signal levels from the bus to levels that the microprocessor uses. When transmitting, it converts signals from microprocessor level to the bus level.

Several types of node controllers are used with functionality that matches the type of devices they are controlling and communicating with.

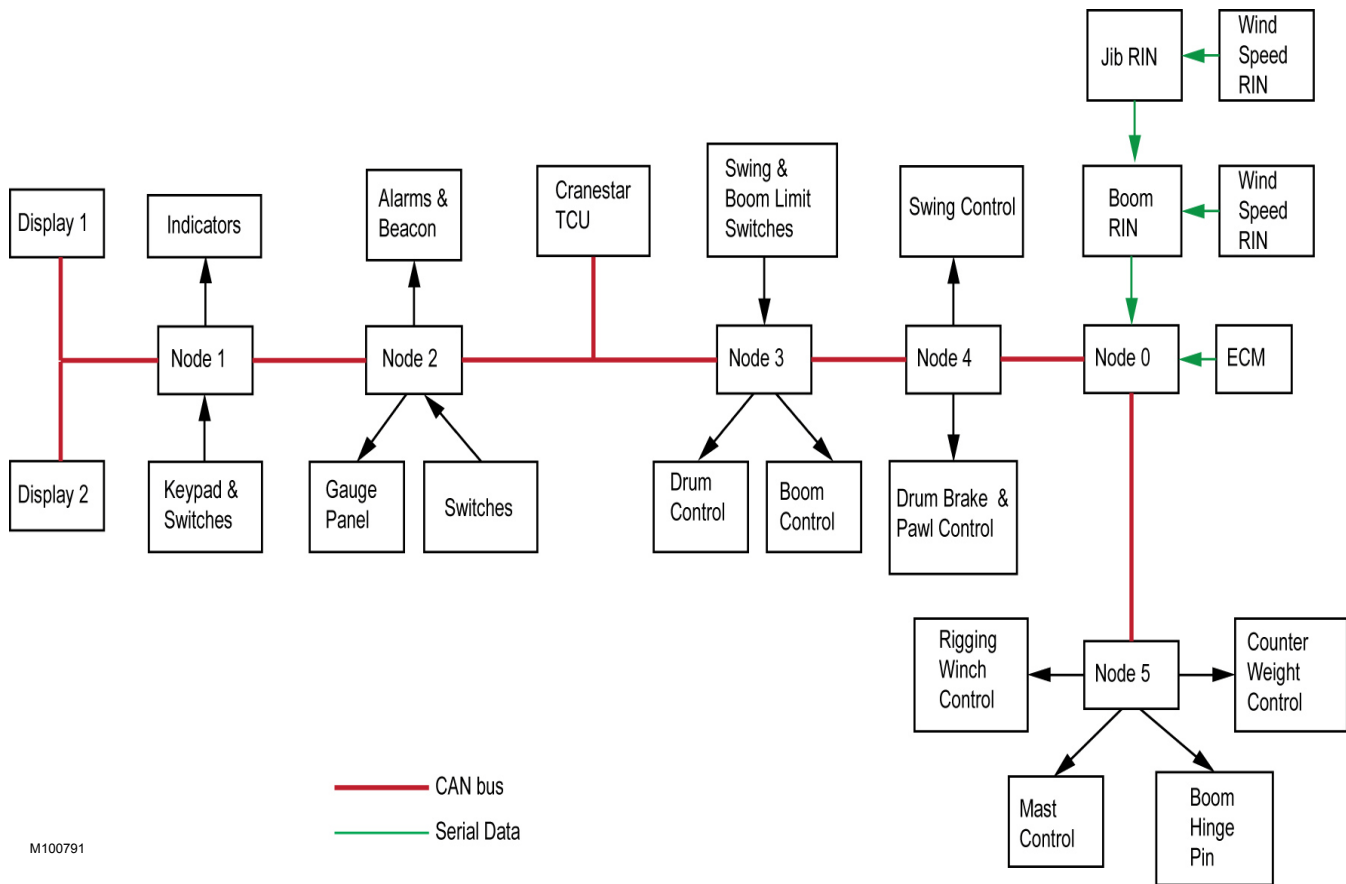

M100791

Figure 3-2. CAN Bus Major Functions

Master Node (Node 1)

The microprocessor within the master node executes the main control program for crane operation and contains memory for lookup information such as load charts. Digital inputs and outputs communicate with low current digital devices within the cab such as keypads, indicators, and control switches.

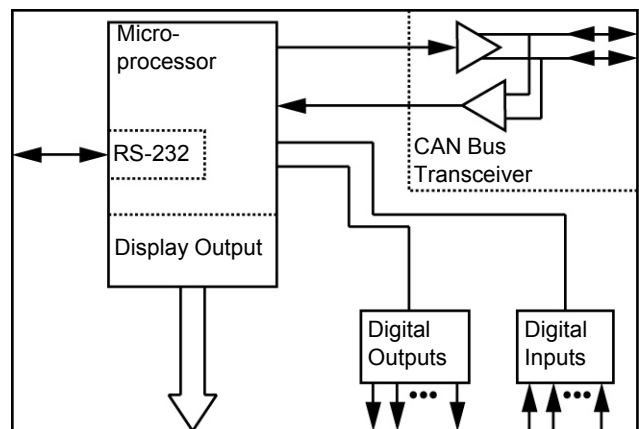

M100792

Figure 3-3. Master Node

Engine Node (Node 0)

The microprocessor within the engine node communicates with the engine control module (ECM). Digital outputs drive relays within the node that control power buses. Node 0 also provides power and the serial communication connections to the boom and jib remote input nodes (RINs).

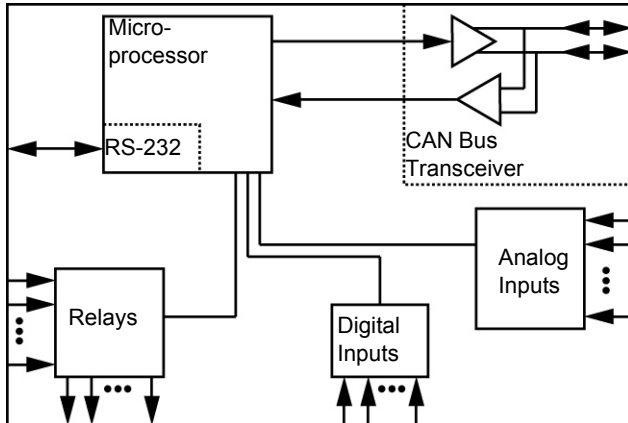

M100793

Figure 3-4. Engine Node

Side Console Node (Node 2)

The microprocessor within the console node communicates with low current control and display devices within the cab. A/D converters allow the node to read analog input signals of devices that have variable input levels, such as the hand and foot throttles, and translate them to digital values that the microprocessor can read. Digital inputs read the state of cab control switches and free fall safety latch pedals. Digital outputs drive the gauge panel, alarms, beacon, and control handle thumpers.

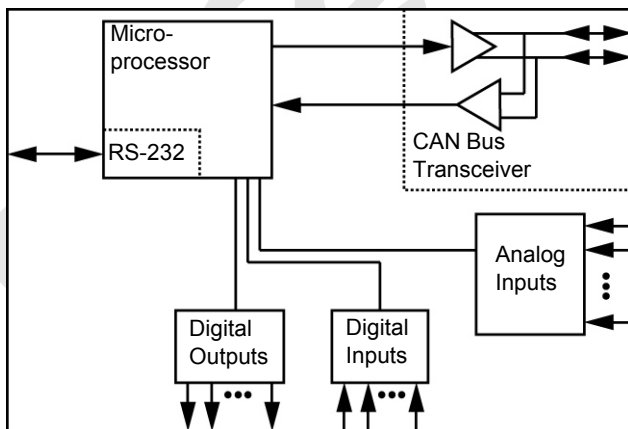

M100794

Figure 3-5. Side Console Node

Universal Nodes (Nodes 3–5)

The microprocessors within the universal nodes communicate with the hardware controls, switches, and sensors on the rotating bed.

A/D converters allow the node to read analog input signals of devices that have variable input levels, such as pressure transducers, and translate them to digital values that the microprocessor can read.

Digital inputs read the state of input devices that are either on or off. Digital outputs can drive devices that are either on or off by sending a high or low signal. They may also drive devices that use variable analog inputs by using pulse width modulation (PWM) to vary the average signal level.

Encoder inputs read the pulses from incremental encoders and convert them to digital values that can be read by the microprocessor. These are used for rotational speed, direction, and position sensing.

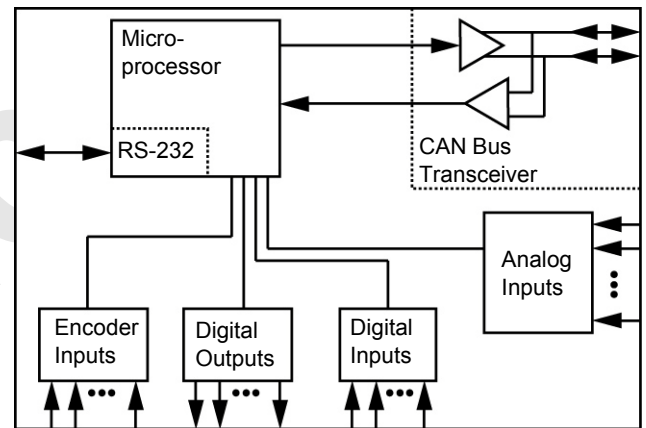

M100795

Figure 3-6. Universal Node

Pressure Transducers

A universal node provides power to a pressure transducer. The pressure transducer produces an analog input signal to the universal node that is proportional to the hydraulic pressure at the transducer connection. The universal nodes monitor hydraulic pressures to use as feedback in control algorithms and to provide status information to the operator. Pressure transducers are used to monitor:

- Control handle pressures
- Drum system pressures
- Swing system pressure
- Accessory system pressure
- Cooler fan pressure

Motor Speed Sensors

A universal node provides power to Hall-effect speed sensors within the hydraulic motors that drive the drums and rotational bed. A gear wheel within the motor has teeth that move past the speed sensor as a motor shaft spins, causing the sensor to produce two square-wave signals that are offset with a 90° phase delay.

The frequency of the square waves is determined by the number of teeth on the circumference of the gear wheel and shaft speed. The rotational direction is determined by which signals phase leads the other. Software uses the square-wave frequency and phase information to calculate the rotational speed and direction of the motor.

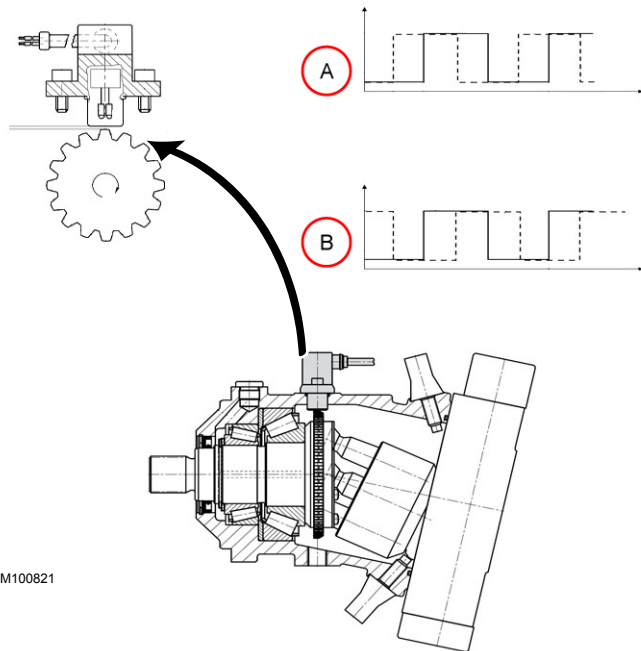

Figure 3-7. Motor Speed Sensor

| Item | Description |
|------|------------------------------------|
| A | Clockwise Rotation Signals |
| B | Counter-Clockwise Rotation Signals |

Drum Free Fall Sensors

Universal node 5 provides power to an incremental encoder within the free fall sensors of Drum 1 and 2. As drum rotation causes the encoder shaft to rotate, the encoder produces two square-wave signals that are offset with a 90° phase delay.

The number of pulses produced is proportional to the amount of shaft rotation. The rotational direction is determined by which signals phase leads the other. Software then uses the pulse count and phase information to calculate drum position and rotational direction.

Limit Switches — Single Contact

In the non-tripped state, a universal node provides power to the normally closed contact. The universal node reads the applied power back through the normally closed contact as a logic high. When the switch is tripped, the normally closed contact opens, breaking the path of power through the common terminal. The universal reads this as a logic low.

Limit Switches — Dual Contact

In the non-tripped state, a universal node provides power to the normally closed contact and grounds the normally open contact. The universal node reads the applied power through the normally closed contact back through the common center terminal as a logic high. When the switch is tripped, the normally closed contact opens, breaking the path of power through the common terminal. At the same time, the normally open contact closes, grounding the common terminal and sending the universal I node a logic low signal.

Limit switches are used to sense the travel limits of:

- Swing limit
- Drum 1 and 2 minimum bail limits
- Maximum boom angle
- Boom and luffing jib upper and lower block up limits
- Minimum and maximum luffing jib angles

Solenoids

Solenoids activate hydraulic valves and provide control of:

- Boom raise and hinge pin cylinders
- Brake cylinders
- Counterweight cylinders and pins
- Cab tilt cylinders
- Assembly cylinder
- Drum motors
- Swing motor
- Handle Selects
- Horse power over-ride
- Load sense shifting
- Travel pilot
- Pilot pressure unloading
- Cooler fan pump
- Proportional pressure control
- Free fall enables
- Auto grease control

Mast Angle Sensors

A universal node provides power to the mast angle sensor. The sensor outputs an analog signal that is proportional to the sensor angle. The universal node reads this output voltage and software derives the mast angle based upon the signal level.

Swing/Travel Alarms

A universal node drives the right and left side swing/travel alarms with a digital output whenever the swing pump or travel motors are being driven.

Load Pin Sensors

A universal node provides power to the load pin sensors. A strain gauge within the load pin produces an analog output current that is proportional to the load. The universal node reads this output current and software derives the value of the load based upon the current level.

Temperature Sensors

A universal node provides power to the temperature sensors. The sensor produces an analog output voltage that is proportional to temperature. The universal node reads this output voltage and software derives the value of the load based upon the current level.

Fuel Level Sensor

A universal node provides power to the fuel level sensor. The sensor transducer produces a sound impulse that reflects off of the fuel surface and bottom of the fuel tank.

A micro-controller in the fuel sensor uses the echo return times to calculate the distance from the fuel surface to the bottom of the tank and sends the universal node an analog voltage that is proportional to the fuel level.

Hydraulic Fluid Level Sensor

A universal node provides power to the hydraulic level sensor. The sensor has a capacitive probe that is immersed in the hydraulic fluid. The level of hydraulic fluid determines the capacitance of the probe.

A micro-controller in the probe translates the probe capacitance to an analog output voltage that is proportional to the fluid level and sends this to a universal node.

Pressure and Vacuum Switches

Pressure and vacuum switches are normally closed and open when the vacuum or pressure level exceeds the setting of the switch. In the non-tripped state, a universal node provides power to the normally closed contact.

The universal node reads the applied power through the normally closed contact back through the center terminal as a logic high. When the switch is tripped, the normally closed contact opens, breaking the path of power through the center terminal and the universal node reads this as a logic low.

Setup Remote

A universal node provides power to the setup remote. The function power switch provides power to the individual control switches when closed. The individual switches are single pole triple throw switches route the supplied power back to the universal node when closed. The universal node interprets this as a command and drives the corresponding function. An emergency stop switch opens the power circuit from the universal node, ceasing commands and movement. The functions controlled by the remote setup are:

- Mast Cylinders Extend/Retract
- Boom Hinge Pins Engage/Disengage
- Counterweight Pins Engage/Disengage
- Right Counterweight Raise/Lower
- Left Counterweight Raise/Lower

Graphic Nodes

Two graphic nodes reside on the CAN Bus. Each graphic node contains a display module and graphic controller. The screen images themselves are contained in the code of the graphic node. Data values to display within the screen images, are passed to the graphic nodes over the CAN Bus.

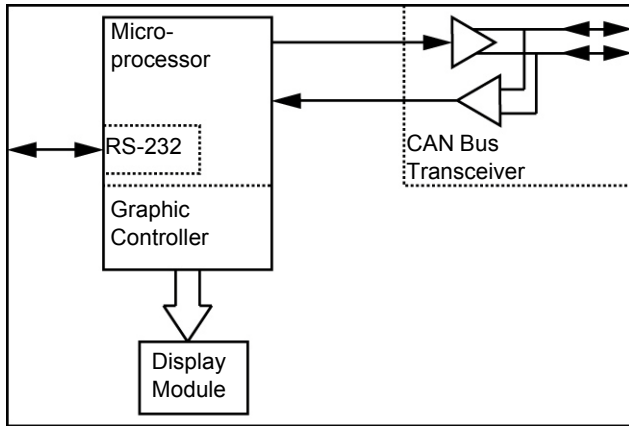

M100798

Figure 3-8. Graphic Node

Wind Speed Remote Input Node

A wind speed remote input node is used at the luffing jib. The node provides power to the wind speed sensor and reads the analog data output of the sensor. Wind speed RIN output data connects to the luffing jib RIN and is a serial data output. The data is passed from the luffing jib wind speed RIN to the luffing jib RIN, then to the boom RIN, and finally onto node 0.

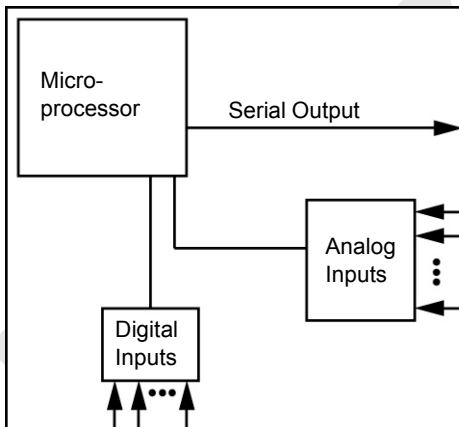

M100799

Figure 3-9. Wind Speed Nodes

Boom and Luffing Jib Remote Input Nodes

The boom RIN contains digital inputs to read the block-up and jib angle limit switches. The boom RIN also provides power to the boom angle sensor and reads the analog data output of the sensor.

Boom RIN data connections connect to node 0. Boom RIN data is not communicated over CAN Bus, but rather over a serial data output that node 0 reads.

The luffing jib RIN contains digital inputs to read the block-up limit switches. The boom RIN also provides power to the upper and lower load pin sensors and the luffing jib angle sensor and reads the analog data outputs of these sensors.

Luffing jib RIN output data connects to the boom RIN and is a serial data output like the boom RIN. The boom RIN then passes the luffing jib data to node 0.

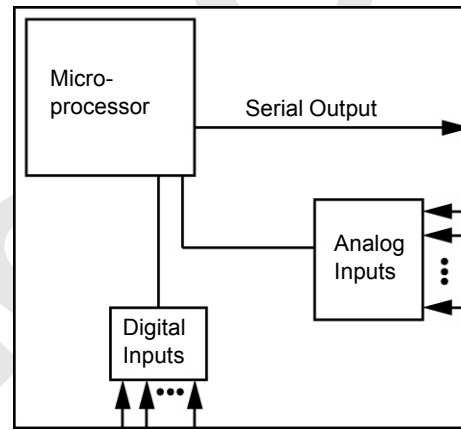

M100799

Figure 3-10. Remote Input Nodes

SOLENOID VALVE IDENTIFICATION

Each hydraulic solenoid valve (HS) is assigned a number (#) for troubleshooting. The wire number of each solenoid can be found in the electrical schematics.

Each HS-# is determined as follow: the first number is the universal node number and the second two numbers are the digital output assigned to that solenoid on that node. For example, HS-311 = Node 3, Digital Output 11 (DO11).

| HS # | Description | Wire # |
|--------|-------------------------------------|--------|
| HS-302 | Main Valve Combined Flow | 33D |
| HS-303 | Horse Power Override | 33F |
| HS-304 | Load Sense Shifting | 33H |
| HS-308 | Drum 2 Motor Control | 36D |
| HS-309 | Drum 1 Motor Control | 36F |
| HS-311 | Drum 4 Up | 34B |
| HS-312 | Drum 4 Down | 34D |
| HS-313 | Drum 1 Up | 34F |
| HS-314 | Drum 1 Down | 34H |
| HS-315 | Drum 2 Up | 34R |
| HS-316 | Drum 2 Down | 34P |
| HS-317 | Drum 3 Up | 34M |
| HS-318 | Drum 3 Down | 34S |
| HS-319 | Select Handle 3 to Drum 4 Up | 34U |
| HS-320 | Select Handle 3 to Drum 4 Down | 34W |
| HS-321 | Select Handle 4y to Drum 1 Up | 34Z |
| HS-322 | Select Handle 4y to Drum 1 Down | 34b |
| HS-323 | Select Handle 4y to Drum 3 Up | 34d |
| HS-324 | Select Handle 4y to Drum 3 Down | 34f |
| HS-407 | Accessory Enable | 46B |
| HS-409 | Swing Control Right | 46F |
| HS-410 | Swing Control Left | 46H |
| HS-411 | Travel Pilot | 44B |
| HS-412 | Drum 2 Brake | 44D |
| HS-413 | Drum 1 Brake | 44F |
| HS-414 | Swing Brake | 44H |
| HS-415 | Travel High Speed | 44R |
| HS-416 | Drum 4 Brake | 44P |
| HS-417 | Drum 3 Brake | 44M |
| HS-418 | Drum 4 Pawl Out | 44S |
| HS-419 | Drum 4 Pawl In | 44U |
| HS-420 | Drum 1 Pawl Out | 44W |
| HS-421 | Drum 1 Pawl In | 44Z |
| HS-422 | Drum 3 Pawl In | 44b |
| HS-423 | Drum 3 Pawl Out | 44d |
| HS-424 | Pilot Pressure Unloading | 44f |
| HS-502 | Accessory Pump Pressure Control | 53D |
| HS-503 | Accessory Pump Displacement Control | 53F |
| HS-504 | Cooler Fan Pumps Control | 53H |
| HS-505 | Rigging Winch Out | 53P |
| HS-506 | Rigging Winch In | 53R |
| HS-507 | Free Fall Drum 1 Enable | 56B |
| HS-508 | Free Fall Drum 2 Enable | 56D |
| HS-509 | Auto Grease Control | 56F |
| HS-511 | Counterweight Pins In | 54B |
| HS-512 | Counterweight Pins Out | 54D |
| HS-513 | Counterweight Cylinder Left Up | 54F |
| HS-514 | Counterweight Cylinder Left Down | 54H |
| HS-515 | Cab Tilt Cylinder Up | 54R |
| HS-516 | Counterweight Cylinder Right Down | 54P |
| HS-517 | Counterweight Cylinder Right Up | 54M |
| HS-518 | Cab Tilt Cylinder Down | 54S |
| HS-519 | Boom Hinge Pins In | 54U |
| HS-520 | Boom Hinge Pins Out | 54W |
| HS-521 | Assembly Cylinder Retract (up) | 54Z |
| HS-522 | Assembly Cylinder Extend (down) | 54b |
| HS-523 | Mast Raise Cylinder Extend | 54d |
| HS-524 | Mast Raise Cylinder Retract | 54f |

CIRCUIT BREAKERS

Alternator Circuit

For the Tier 3 engine, a 120-amp circuit breaker (CB-0) is in the circuit between the alternator and the starter. The circuit breaker is located next to the starter (View A, [Figure 3-11](#)).

For the Tier4 engine, a 150-amp circuit breaker (CB-0) is in the circuit between the alternator and the batteries. The circuit breaker is located on the rear of the battery box in the right-side enclosure (View B, [Figure 3-11](#)).

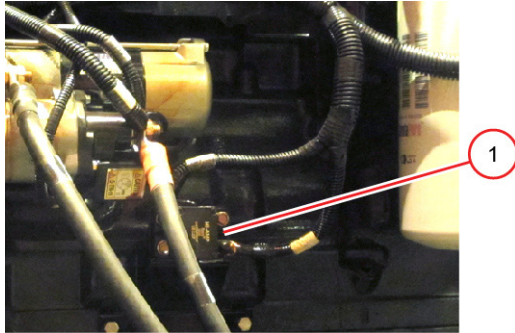

M103676

View A
At Starter on Rear of Engine

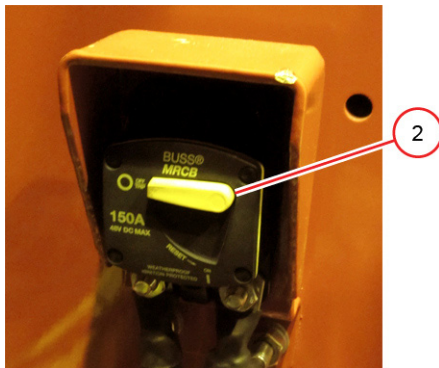

M103677

View B
Right Enclosure on Battery Box

| Item | Circuit Breaker | Amps | Description |
|------|-----------------|------|---------------|
| 1 | CB-0 | 120 | Tier 3 Engine |
| 2 | CB-0 | 150 | Tier 4 Engine |

Figure 3-11. Alternator Circuit Breaker

Engine Node

Circuit breakers CB-1 through CB-9 are mounted in the engine node 0 ([Figure 3-12](#)).

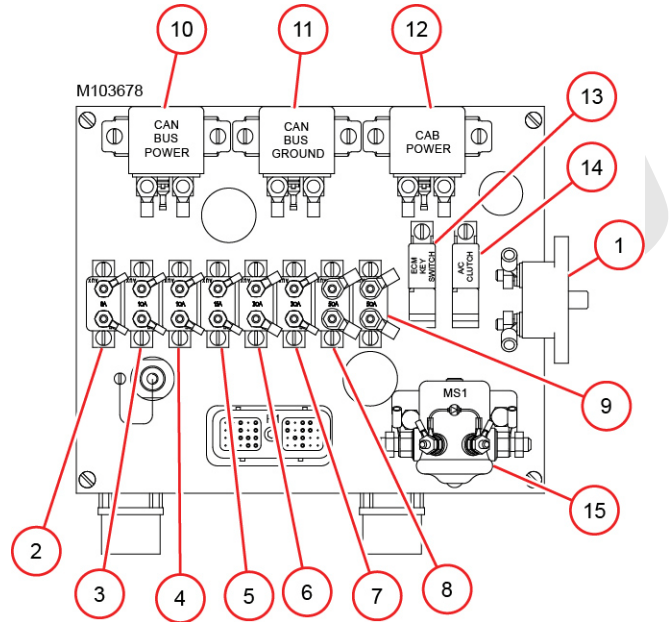

| Item | Amps | Description |
|------------------------|------|-------------------------|
| Circuit Breaker | | |
| 1 | 60 | Main System 24 V Power |
| 2 | 8 | ECM Key Switch |
| 3 | 10 | Cummins Diagnostics |
| 4 | 10 | Key Switch |
| 5 | 15 | Air Compressor Clutch |
| 6 | 30 | Cummins ECM |
| 7 | 30 | Starter Solenoid |
| 8 | 50 | CAN-Bus Power |
| 9 | 50 | Cab Power |
| Relays | | |
| 10 | 50 | CAN-Bus Power |
| 11 | 50 | CAN-Bus Ground |
| 12 | 50 | Cab Power |
| 13 | 10 | ECM Key Switch |
| 14 | 10 | Air Compressor Clutch |
| 15 | MS1 | Starter Contactor Relay |

Figure 3-12. Engine Node Circuit Breakers

operator cab

Four circuit breakers and four fuses are mounted in the rear console behind the operator seat (Figure 3-13).

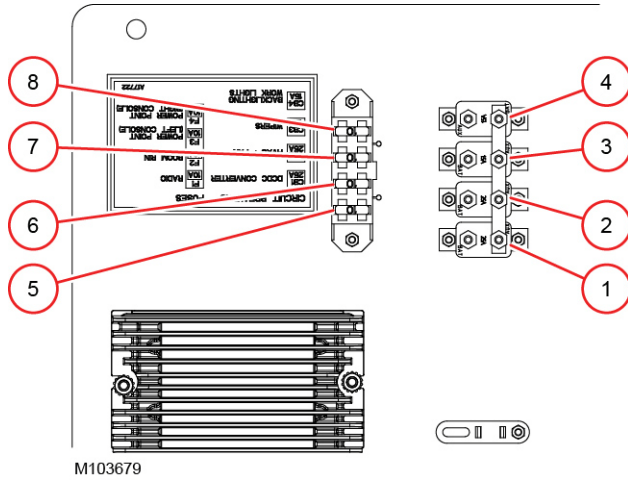

| Item | Amps | Description |
|-------------------------|------|--------------------------------|
| Circuit Breakers | | |
| 1 | CB-1 | 25 DC Converter |
| 2 | CB-2 | 25 Air Conditioning/Heater Fan |
| 3 | CB-3 | 15 Front and Overhead Wiper |
| 4 | CB-4 | 15 Back Lighting / Work Lights |
| Fuses | | |
| 5 | F1 | 10 Radio |
| 6 | F2 | 10 Boom RIN |
| 7 | F3 | 10 Power Point (Left Console) |
| 8 | F4 | 10 Power Point (Right Console) |

Figure 3-13. operator cab Circuit Breakers

Grid Heater

For the Tier 3 engine, a 120 amp circuit breaker (3) and one high power relay contactor (4) is located in the grid heater junction box (1) mounted in the left-front side of the engine compartment.

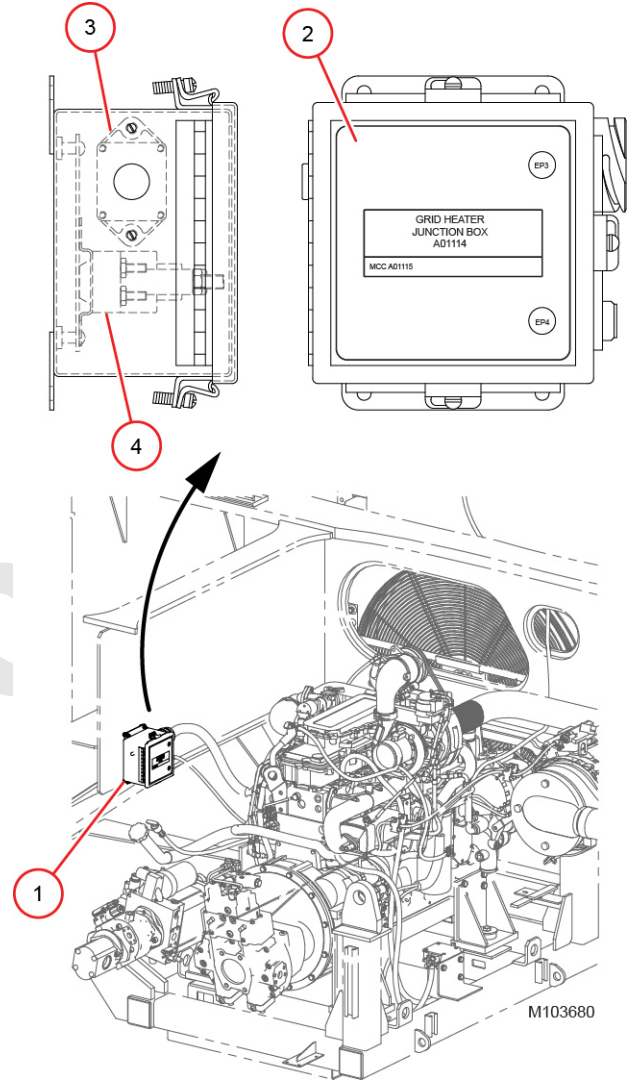

| Item | Description |
|------|--------------------------|
| 1 | Grid Heater Junction Box |
| 2 | Junction Box Cover |
| 3 | 120 amp Circuit Breaker |
| 4 | 100 amp Contactor Relay |

Figure 3-14. Grid Heater Junction Box

Exhaust Aftertreatment System

For the Tier 4 engine, three circuit breakers and five relays are located inside the exhaust aftertreatment junction box (1, [Figure 3-15](#)) mounted in the left-front side of the engine compartment.

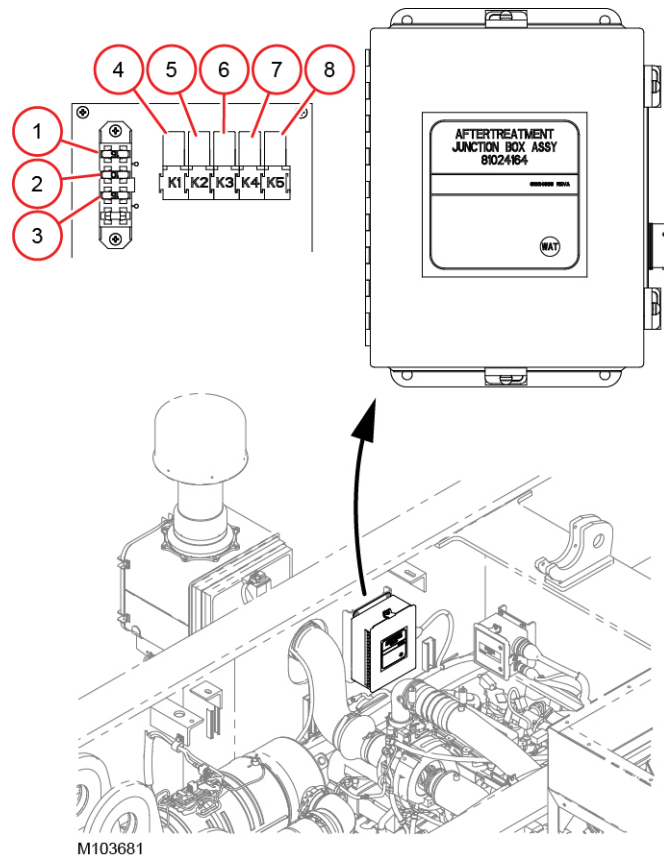

M103681

| Item | Amps | Description |
|-------------------------|-------|-----------------------------|
| Circuit Breakers | | |
| 1 | CB-10 | 15 DEF Supply Module |
| 2 | CB-11 | 10 Aftertreatment Sensors |
| 3 | CB-12 | 15 DEF Heaters |
| Relays | | |
| 4 | K1 | 10 DEF Pressure Hose Heater |
| 5 | K2 | 10 DEF Return Hose Heater |
| 6 | K3 | 10 DEF Suction Hose Heater |
| 7 | K4 | 10 DEF Supply Module |
| 8 | K5 | 10 Aftertreatment Sensors |

Figure 3-15. Exhaust Aftertreatment Circuit Breakers

240 VAC Electric System

The circuit breakers for the optional cold weather heater package and the lighting packages are located in the load center (1, [Figure 3-16](#)) mounted in the right-side enclosure.

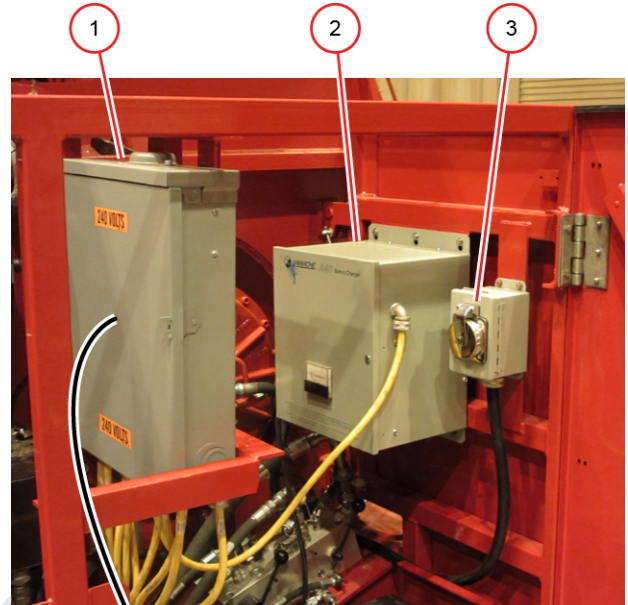

M103682

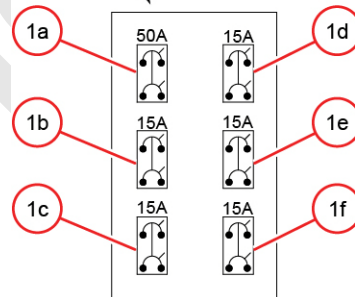

| Item | Description |
|------|--|
| 1 | Load Center |
| 1a | 50A Main Circuit Breaker |
| 1b | 15A Circuit Breaker: Rotating Bed Work Lights |
| 1c | 15A Circuit Breaker: Boom Work Lights |
| 1d | 15A Circuit Breaker: Engine Oil Heater, Battery Pad Heaters, and Engine Coolant Heater |
| 1e | 15A Circuit Breaker: Hydraulic Tank Heater |
| 1f | 15A Circuit Breaker: Cab Console Heater and Battery Charger |
| 2 | Battery Charger |
| 3 | 240 VAC Receptacle |

Figure 3-16. 240 VAC Load Center

CHECKING AND REPLACING ELECTRICAL COMPONENTS



DANGER

Electrical Shock Hazard

Ensure that the battery cables are disconnected from the batteries before loosing any electrical connections.

1. Visually inspect all electrical harnesses and cables every month or at 200 hours of service life for the following:

- Damaged, cut, or deteriorated harness loom covering
- Damaged, cut, or abraded individual wires or cable insulation
- Exposed bare copper conductors
- Kinked, crushed, or flattened harnesses or cables
- Blistered, soft, or degraded wires and cables
- Cracked, damaged, or badly corroded battery terminal connections
- Inspect all machine ground connections for damaged terminals or excessive corrosion
- Other signs of significant deterioration

If any of these conditions exist, evaluate the harness for repair or replacement

2. At the same service interval, visually inspect all Controller Area Network (CAN) nodes and electrical junction boxes for the following:

- Damaged or loose connectors
- Damaged or missing electrical clamps or tie straps
- Excessive corrosion or dirt on the junction boxes

- Loose junction box mounting hardware

If any of these conditions exist, address them appropriately.

3. Harness and battery cables operating in **Zone C** ([Table 3-1.](#)) are recommended to be replaced after 10,000 hours of service life.
4. Harness and cables operating in **Zone A** and **B** with high ambient temperatures and high duty circuits could see electrical service life reduced by 25% to 40%. It is recommended to replace these assemblies after 8,000 hours of service life.
5. Harness and cable assemblies operating in **Zone D** and **E**, should expect a degrade of mechanical properties and long term exposure to these cold temperatures will negatively impact service life. It is recommended for these electrical harnesses and cable assemblies to be inspected to [step 1](#) above as service life may be more than 10,000 hours.
6. Harness and cable assemblies operating in salt water climates could see a significant reduction in service life. Therefore it is recommended for these electrical harnesses and cable assemblies to be inspected to [step 1](#) above as service life may be more than 8,000 hours.

Table 3-1. Climate Zone Classifications

| Zone | Zone Description |
|------|---|
| A | Tropical Moist: All months average above 64°F (18°C). Latitude: 15° - 25° N & S |
| B | Dry or Arid: Deficient precipitation most of the year. Latitude: 20° - 35° N & S |
| C | Moist Mid-Latitude: Temperate with mild winters. Latitude: 30° - 50° N & S |
| D | Moist Mid-Latitude: Cold winters. Latitude 50° - 70° N & S |
| E | Polar: Extremely cold winters and summers. Latitude: 60° - 75° N & S |

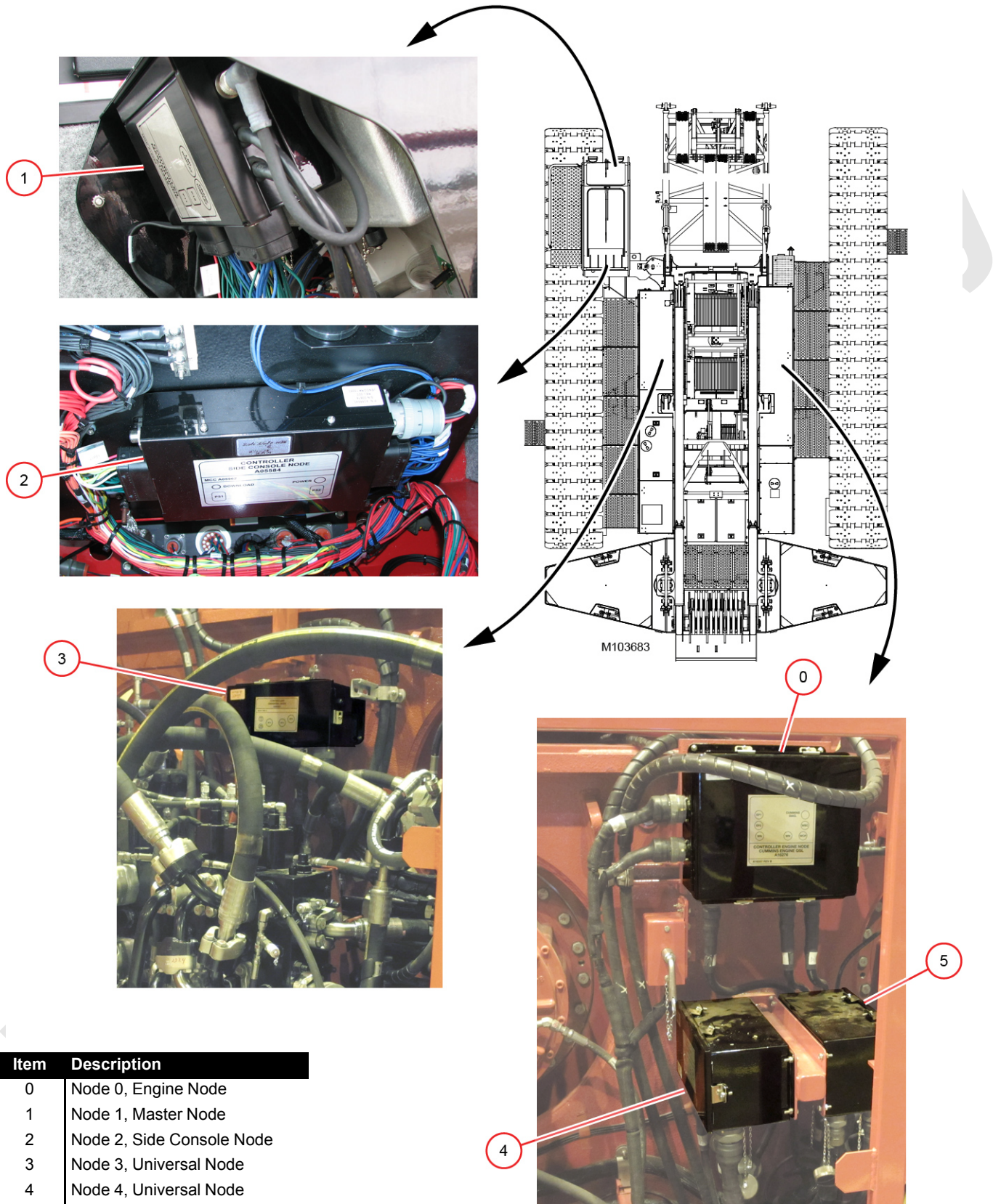
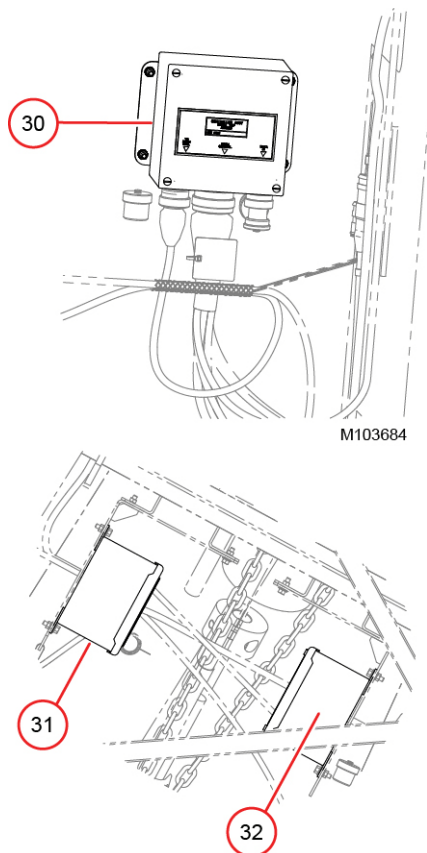

Figure 3-17. Node Locations

Node Locations

Figure 3-17 shows the locations of the nodes on the rotating bed. Figure 3-18 shows the locations of the nodes in the boom and luffing jib points.



| Item | Description |
|------|--------------------------------------|
| 30 | Node 30, Boom Node |
| 31 | Node 31, Luffing Jib Node |
| 32 | Node 32, Luffing Jib Wind Speed Node |

Figure 3-18. Node Locations

Component to Node Identification

Table 3-2 shows which major functions are connected to each node. For a complete list of functions controlled by each node, refer to the Electrical Schematic at the end of this section.

Find the desired component item in this index. Check the component item node location, then refer to the indicated node to find the test voltage for that item.

Table 3-2. Component to Node Identification

| Component | Location |
|---------------------------------------|-------------------|
| Accessory System Components | Node 5 |
| Alarms | Nodes 2 |
| Air Conditioning Clutch | Node 0,2 |
| Auto Lube Pumps | Node 5 |
| Block Up Limit (Boom) | Node 30 |
| Block Up Limit (Luffing Jib) | Node 31 |
| Cab Switches and Controls | Nodes 1 & 2 |
| Cab Power | Node 0 |
| Cab Tilt | Node 2 |
| Control Handles | Node 2 & 3 |
| Drum 4 Components | Nodes 1 & 4 |
| Engine Control Module | Node 0 |
| Engine Fuel Level Sensor | Node 5 |
| Filters | Node 4 |
| Free Fall Components | Nodes 1, 2, & 5 |
| Hydraulic Fluid Level and Temperature | Node 4 |
| Hydraulic Vacuum Switch | Node 4 |
| Limits | Node 3, 5 |
| Drum 1 Components | Node 3 |
| Drum 2 Components | Node 3 |
| Drum 3 Components | Node 1 & 4 |
| Pressure Senders | Node 3 & 5 |
| Swing Components | Node 1, 3, 4, & 5 |
| Throttle (Hand and Foot) | Node 2 |
| Travel Components | Nodes 1, 3, & 4 |
| Wind Speed Indicator (Boom) | Node 30 |
| Wind Speed Indicator (Luffing Jib) | Node 31 |

Pump and Motor Voltages and Currents

[Table 3-3](#) shows the voltages and currents of the pumps, hoists, and travel motors.

Table 3-3. Pump and Motor Voltages and Currents

| |
|---|
| Swing Pump |
| 1.6 or 8.8Vdc nominal |
| 200 to 600mA ^{note 1&2} |
| Hoist Motors |
| 4.5 to 10Vdc |
| 180 mA to 450mA ^{note1&2} |
| Travel Motors |
| 0 or 24Vdc nominal |
| 0 or 600mA nominal ^{note 1} |
| Note 1: Resistance increases as the temperature rises on the pump or motor solenoid coil resulting in decreased current values when measured with a meter. The listing in the table is the current range for a 70°F (21°C) coil. |
| Note 2: The node regulates displacement of the pump or motor with a PWM output. The values represent the beginning and end of the control range. |

Abbreviations

The following abbreviations are used in test voltage tables:

| | |
|------------|----------------------------------|
| AC | Alternating Current |
| A/C | Air Conditioning |
| AI | Analog Input |
| AO | Analog Output |
| AUX | Auxiliary |
| CAN | Controller Area Network |
| CANH | Controller Area Network - High |
| CANL | Controller Area Network - Low |
| CHA or CHB | Channel A or B |
| DC | Direct Current |
| DI | Digital Input |
| DO | Digital Output |
| EC | Encoder Control |
| ENC | Encoder Number Count |
| GND | Ground |
| ID | Identification |
| LED | Light Emitting Diode |
| Max. | Maximum |
| Min. | Minimum |
| M/C | Motor Control |
| N/A | Not Applicable |
| N/C | No Connection |
| NO | Number |
| NS | Node Select |
| Opt. | Optional |
| P | Pin |
| P/C | Pump Control |
| RCL | Rated Capacity Indicator/Limiter |
| V | Volt or Volts |
| VDC | Volts Direct Current |
| W | Wire |

Checking Electrical Inputs/Outputs (Using the Test Box)

Troubleshoot components on the main display, system diagnostic screen first. Perform additional testing with the Electrical Test Kit at universal nodes or Manitowoc Unit Tester at all nodes. The Electrical Test Kit or Manitowoc Unit Tester can be ordered from your Manitowoc dealer.

The breakout test kit provides a breakout of the node signals to easily probed bayonet connections. Each node connector (2) [Figure 3-19 on page 3-15](#) is keyed uniquely and requires a matching keyed test harness assembly (4) from the Electrical Test Kit.

The output terminals of the electrical test box (3) are labeled A1 through 40V, corresponding to node connector (2) pin numbers. Both a number and letter are included in each designator because some systems number the pin connections and others letter the connections. Use either the numbers or letters as they apply to your system.

I/O node and pin numbers are contained in the Test Volt tables.

To probe a fault at a universal node with the Electrical Test Kit:

1. Shutdown the engine and turn the engine key switch to off.
2. Determine which signal contains the suspected fault.
3. Disconnect the node cable (1) from the node connector (2) containing the signal of the suspected fault.
4. Connect the electrical test box (3) and test harness (4) between the node connector (2) and disconnected node cable (1).
5. Turn the engine key switch to on and activate the suspected fault.
6. Use a multimeter (5) and bayonet test probes (6) to probe signals at the test box (3) as needed in conjunction with toggling node outputs.

3

M100782

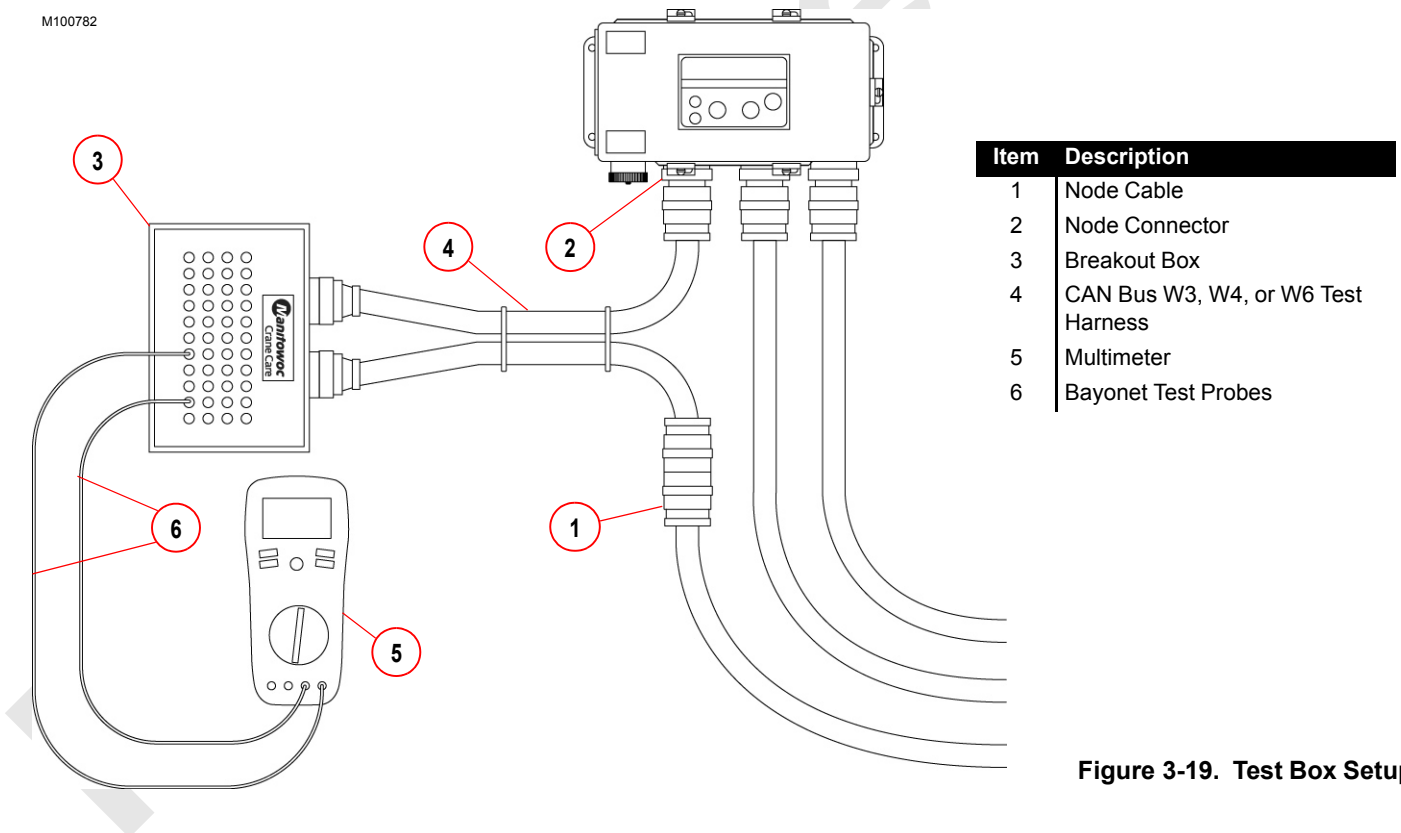

Figure 3-19. Test Box Setup

Checking Electrical Inputs/Outputs (Using the Test Board)

Troubleshoot components on the main display, system diagnostic screen first. Perform additional testing with the Electrical Test Kit at universal nodes or Manitowoc Unit Tester at all nodes. The Electrical Test Kit or Manitowoc Unit Tester can be ordered from your Manitowoc dealer.

The breakout test kit provides a breakout of the node signals to easily probed terminal connections. Each node connector (2) [Figure 3-20 on page 3-16](#) is keyed uniquely and requires a matching keyed test board assembly (3) from the Electrical Test Kit.

The output terminals of the electrical test board assembly (3) are labeled A through V, corresponding to node connector (2) pin numbers.

I/O node and pin numbers are contained in the Test Volt tables.

To probe a fault at a universal node with the Electrical Test Kit:

1. Shutdown the engine and turn the engine key switch to off.
2. Determine which signal contains the suspected fault.
3. Disconnect the node cable (1) from the node connector (2) containing the signal of the suspected fault.
4. Connect the electrical test board assembly (3) between the node connector (2) and disconnected node cable (1).
5. Turn the engine key switch to on and activate the suspected fault.
6. Use a multimeter (4) and needle test probes (5) to probe signals at the test board assembly (3) as needed in conjunction with toggling node outputs.

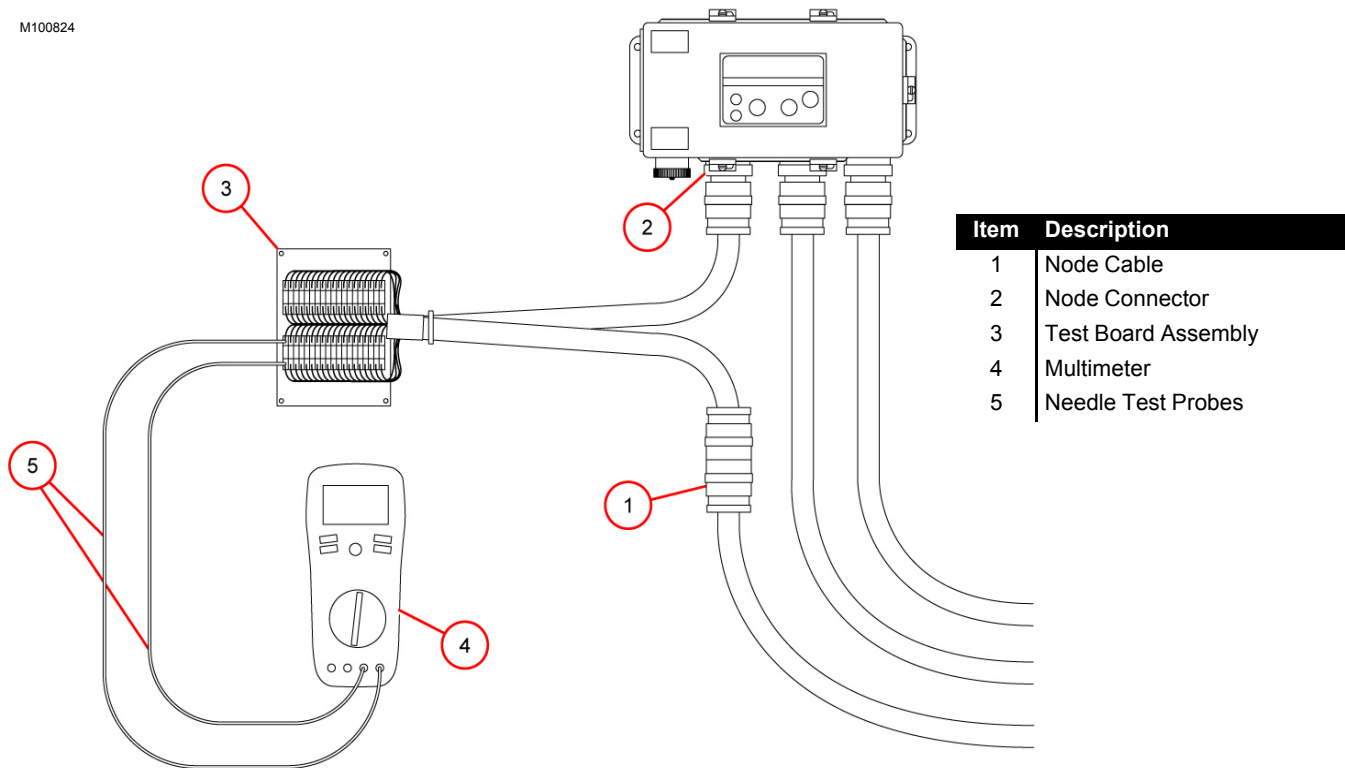

Figure 3-20. Test Board Setup

TEST VOLTAGES

Node Heading Descriptions

The following are descriptions of the headings of the tables on the following pages.

The Receptacle Number — indicates the CAN Bus system node number, cable, receptacle number, and pin number code (**34-R**) is as follows:

The number **34** is the **cable number**.

The number **3** is the **node number**.

The number **4** is the **receptacle number** where item is located on the node.

The last number **R** is the **pin number** of the receptacle.

Function Type — indicates the type of connection - such as power, ground, analog output (AO), analog input (AI), digital input (DI), or digital output (DO).

Receptacle/Pin No.— (Engine Node 0 only) indicates input to receptacle number and pin number code (J2-1).

Wire No. — (Engine Node 0 only) indicates wire to computer receptacle (0107) or wire number code (6C12A).

Description — indicates the component item.

CAN Packet Number — indicates location of items for master node 1, node 2, universal nodes (3 and 4), boom remote input node and luffing jib remote input node. Engine node 0 does not have packet code numbers.

Master node 1:

CAN92-6-32 (Swing Park Switch) indicates where the inputs/outputs are located on the node.

CAN92 is the **packet** location number.

Number **6** is the **bank** where information is stored.

Number **32** is the **identifier** for that item.

Node 1 — Master

See Electrical Schematic 81019880, Sheets 7 and 18 (at end of this section).

| Connector Number | Function Type | Description | Test Voltages | CAN Packet Number |
|------------------|--|--------------------------------------|--------------------------|-------------------|
| J1 | Receptacle Front Console – (Not Used Terminals are Omitted) | | | |
| P11-1 | 24 Volts | Input Power | 24 Volts Nominal | |
| P11-3 | DI-12 | Display Scroll Up Switch | 0 Volts Off; 24 Volts On | CAN92-4-8 |
| P11-4 | DI-14 | Display Scroll Down Switch | 0 Volts Off; 24 Volts On | CAN92-4-32 |
| P11-5 | DI-31 | Display Exit Switch | 0 Volts Off; 24 Volts On | CAN92-6-64 |
| P11-6 | DI-9 | Display Enter Switch | 0 Volts Off; 24 Volts On | CAN92-4-1 |
| P11-8 | DO-3 | RCL Warning L.E.D. | 0 Volts Off; 24 Volts On | CAN92-1-4 |
| P11-10 | DO-6 | RCL Caution L.E.D. | 0 Volts Off; 24 Volts On | CAN92-1-32 |
| P11-11 | 24 Volts | Power to Membrane (Display) Switches | 24 Volts Nominal | |
| P11-13 | DI-11 | Limit Bypass Switch | 0 Volts Off; 24 Volts On | CAN92-4-4 |
| P11-15 | DI-32 | Drum 3 Park Switch | 0 Volts Off; 24 Volts On | CAN92-6-128 |
| P11-16 | DI-10 | Confirm Switch | 0 Volts Off; 24 Volts On | CAN92-4-2 |
| P11-17 | DO-2 | Free Fall Enable Switch | 24 Volts Nominal | |
| P11-19 | DO-7 | Free Fall Enable LED Drum 1 | 0 Volts Off; 24 Volts On | CAN92-1-64 |
| P11-20 | DO-5 | Free Fall Enable LED Drum 2 | 0 Volts Off; 24 Volts On | CAN92-1-16 |
| P11-21 | Ground | Ground to Node 2 and Displays 1 & 2 | Ground | |
| P11-24 | DI-30 | Swing Park Switch | 0 Volts Off; 24 Volts On | CAN92-6-32 |
| P11-27 | Ground | Free Fall Enable LED Drum 1 | Ground | |
| P11-28 | Ground | Free Fall Enable LED Drum 2 | Ground | |
| P11-29 | Ground | RCL Caution L.E.D. | Ground | |
| P11-30 | Ground | RCL Warning L.E.D. | Ground | |
| P11-31 | CANH | CAN High Data Line from Node 2 | N/A | |
| P11-32 | CANL | CAN Low Data Line from Node 2 | N/A | |
| P11-33 | DI-27 | Display 1 Switch (RCI Display) | 0 Volts Off; 24 Volts On | CAN92-6-4 |
| P11-34 | DI-29 | Display 2 Switch (Main Display) | 0 Volts Off; 24 Volts On | CAN92-6-16 |
| P11-35 | DI-16 | Free Fall Enable Switch Drum 1 | 0 Volts Off; 24 Volts On | CAN92-4-128 |
| P11-36 | DI-26 | Free Fall Enable Switch Drum 2 | 0 Volts Off; 24 Volts On | CAN92-6-2 |
| J2 | Receptacle – Front Console (Not Used Terminals are Omitted) | | | |
| P12-1 | 24 Volts | Input Power | 24 Volts Nominal | |
| P12-3 | DI-4 | Drum 0 Park Switch | 0 Volts Off; 24 Volts On | CAN92-3-8 |
| P12-7 | DO-9 | Limit Bypass/Swing Park Switch | 24 Volts Nominal | CAN92-2-1 |
| P12-8 | DO-11 | Drums 1, 2, and 3 Park Switches | 24 Volts Nominal | CAN92-2-4 |
| P12-9 | DO-16 | Drum 0,4, and Travel Park Switches | 24 Volts Nominal | CAN92-2-128 |
| P12-11 | 24 Volts | Gauge Panel | 24 Volts Nominal | |
| P12-13 | DI-3 | Drum 1 Park Switch | 0 Volts Off; 24 Volts On | CAN92-3-4 |
| P12-14 | DI-5 | Drum 2 Park Switch | 0 Volts Off; 24 Volts On | CAN92-3-16 |
| P12-15 | DI-24 | Drum 4 Park Switch | 0 Volts Off; 24 Volts On | CAN92-5-128 |
| P12-17 | DO-10 | Overhead Panel | 24 Volts Nominal | CAN92-2-2 |
| P12-21 | Ground | Ground to Node 2 and Displays 1 & 2 | Ground | |

| | | | | |
|--------|-------|---|--------------------------|-------------|
| P12-24 | DI-22 | Engine Run/Start | 0 Volts Off; 24 Volts On | CAN92-5-32 |
| P12-25 | DI-7 | Travel Park Switch | 0 Volts Off; 24 Volts On | CAN92-3-64 |
| P12-26 | DI-17 | Boom Hinge Pins Disengage | 0 Volts Off; 24 Volts On | CAN92-5-1 |
| P12-31 | CANH | CAN High Data Line to Graphical Display | N/A | |
| P12-32 | CANL | CAN Low Data Line to Graphical Display | N/A | |
| P12-33 | DI-19 | DPF Inhibit | 0 Volts Off; 24 Volts On | CAN92-5-4 |
| P12-34 | DI-21 | DPF Regen Initiate | 0 Volts Off; 24 Volts On | CAN92-5-16 |
| P12-35 | DI-8 | Mast Cylinders Retract Switch | 0 Volts Off; 24 Volts On | CAN92-3-128 |
| P12-36 | DI-18 | Mast Cylinders Extend Switch | 0 Volts Off; 24 Volts On | CAN92-5-2 |

Node 2 — Alarms, Switches, and Gauge Panel

See Electrical Schematic 81019880, Sheets 7 through 9 and 19 (at end of this section).

| Connector Number | Function Type | Description | Test Voltages | CAN Packet Number |
|------------------|--|---|--|---------------------|
| J1 | Receptacle – Controls (Not Used Terminal are Omitted) | | | |
| P51-11 | CAN-H | CAN High Data Line | N/A | |
| P51-12 | CAN-L | CAN Low Data Line | N/A | |
| P51-3 | AI-2 | Handle 4y Swing Holding Brake Switch | 0 Volts Off; 24 Volts On | CAN0-2-32 |
| P51-6 | AI-14 | Hand Throttle Input Signal | Low Idle 0.5 Volts; High Idle 4.5 Volts | CAN3-4 ¹ |
| P51-9 | DI-2 | Self Assembly Cylinder Retract | 0 Volts Off; 24 Volts On | CAN36-1-2 |
| P51-10 | DI-3 | Self Assembly Cylinder Extend | 0 Volts Off; 24 Volts On | CAN36-1-4 |
| P51-11 | CAN-H | CAN High Data Line to Node 1 | N/A | |
| P51-12 | CAN-L | CAN Low Data Line to Node 1 | N/A | |
| P51-13 | AI-4 | Switch - Boom Hinge Pins Engage | 0 Volts Off; 24 Volts On | CAN0-2-128 |
| P51-14 | AI-6 | Switch - Boom Hinge Pins Disengage | 0 Volts Off; 24 Volts On | CAN1-2-32 |
| P51-19 | DI-1 | Free Fall Safety Switch Left Pedal | 0 Volts Off; 24 Volts On | CAN36-1-1 |
| P51-20 | DI-4 | Free Fall Safety Switch Right Pedal | 0 Volts Off; 24 Volts On | CAN36-1-8 |
| P51-21 | Ground | Foot Throttle | Ground | |
| P51-22 | Ground | Hand Throttle | Ground | |
| P51-23 | AI-1 | Foot Throttle Input Signal | Low Idle 2.9 – 3.0 Volts; High Idle 0.9 – 1.0 Volts | CAN0-2 ¹ |
| P51-29 | DI-15 | Travel Speed | 0 Volts Off; 24 Volts On | CAN36-2-64 |
| P51-30 | DI-14 | Drum Speed | 0 Volts Off; 24 Volts On | CAN36-2-32 |
| P51-31 | 5 Volts DC | Hand Throttle | 5 Volts | |
| P51-32 | NS1 | Node Select 1 Jumper to Ground | 0 Volts (With Jumper) | |
| P51-37 | DI-8 | Seat Safety Switch | 0 Volts Off; 24 Volts On | CAN36-1-128 |
| P51-38 | DI-6 | Cab Tilt - Down Switch | 0 Volts Off; 24 Volts On | CAN36-1-32 |
| P51-39 | DI-13 | Cab Tilt - Up Switch | 0 Volts Off; 24 Volts On | CAN36-2-16 |
| P51-40 | DI-5 | Air Conditioning - On | 0 Volts Off; 24 Volts On | CAN36-1-16 |
| J2 | Receptacle – Controls (Not Used Terminal are Omitted) | | | |
| P52-1 | DO-7 | Drum 1 Handle (H1) Rotation Indicator | 24 Volts Nominal | CAN20-1-64 |
| P52-2 | DO-3 | Drum 2 Handle (H2) Rotation Indicator | 24 Volts Nominal | CAN20-1-4 |
| P52-3 | DO-6 | Drum 3 Handle (H3) Rotation Indicator | 24 Volts Nominal | CAN20-1-32 |
| P52-4 | DO-2 | Drum 4 Handle (H4) Rotation Indicator | 24 Volts Nominal | CAN20-1-2 |
| P52-5 | DO-5 | RCI Beacon – Light Red | 0 Volts Off, 24 Volts On | CAN20-1-16 |
| P52-6 | DO-13 | Engine Coolant Temperature | 24 Volts Nominal | CAN20-2-16 |
| P52-7 | DO-16 | Engine Oil Pressure | 24 Volts Nominal | CAN20-2-128 |
| P52-8 | DO-9 | Cab Tilt, Drum Speed, Travel Speed Switches | 24 Volts Nominal | CAN20-2-1 |
| P52-9 | DO-19 | Handle 4y Swing Holding Brake Switch | 24 Volts Nominal | CAN20-3-4 |
| P52-10 | DO-12 | Self Assembly Cylinder | 24 Volts Nominal | CAN20-2-8 |
| P52-11 | DO-4 | RCI Beacon Light Amber | 0 Volts Off, 24 Volts On | CAN20-1-8 |
| P52-12 | DO-8 | Free Fall Safety Switch Right Pedal | 24 Volts Nominal | CAN20-1-128 |
| P52-13 | DO-8 | Free Fall Safety Switch Left Pedal | 24 Volts Nominal | CAN20-1-128 |

| | | | | |
|-----------|---|--|--------------------------|-------------|
| P52-15 | DO-1 | RCI Beacon Light Green | 0 Volts Off, 24 Volts On | CAN20-1-1 |
| P52-16 | DO-22 | System Operation Alarm | 0 Volts Off, 24 Volts On | CAN20-3-32 |
| P52-17 | DO-24 | Rated Capacity Indicator/Limiter Fault Alarm | 0 Volts Off, 24 Volts On | CAN20-3-128 |
| P52-19 | DO-18 | Switch - Boom Hinge Pins | 24 Volts Nominal | CAN20-3-2 |
| P52-20 | Ground | Drum 4 Handle (H4) Rotation Indicator | Ground | |
| P52-23 | Ground | Handle (H1, H2, H3) Rotation Indicator | Ground | |
| P52-31 | DO-8 | Seat Safety Switch | 24 Volts Nominal | CAN20-1-128 |
| P52-37 | DO-23 | Foot Throttle | 24 Volts Nominal | CAN20-3-64 |
| P52-38 | DO-20 | Engine Fuel Level | 24 Volts Nominal | CAN20-3-8 |
| J3 | Receptacle – Gauge Panel (Not Used Terminal are Omitted) | | | |
| P53-A | Ground | To Node 3 | 24 Volts Nominal | |
| P53-B | Ground | CAN System Ground | Ground | |
| P53-C | Ground | Cab Frame | Ground | |
| P53-E | 24 Volts DC | Power to Node 3 | Ground | |
| P53-F | 24 Volts | System Volts DC | 24 Volts Nominal | |

*1 – Lower four bits can be multiplied by 5 or 10 depending on sender, then divided by 16 for an estimation of sender voltage.

Node 3 — Drum Control and Limit Switches

See Electrical Schematic 81019880, Sheets 10, 11, 20, and 21(at end of this section).

| Receptacle Number | Function Type | Description | Test Voltages | CAN Packet Number |
|-------------------|--|---|---|------------------------------------|
| J1-WN10 | | I/O Cable — From Node 2 to Node 3 | N/A (option) | |
| J1-WN18 | | I/O Cable — From Node 3 to Node 4 | N/A | |
| J3/W33 | Receptacle — Pressure Sensors, Hydraulic Solenoids, and Swing Limit | | | |
| 33-A | Ground | External LMI Capacity Alarm | Ground | |
| 33-B | DO-1 | External LMI Capacity Alarm | 0 Volts Off; 24 Volts On | CAN21-1-1 |
| 33-C | Ground | Main Valve Combined Flow Control HS-302 | Ground | |
| 33-D | DO-2 | Main Valve Combined Flow Control HS-302 | 0 Volts Off; 24 Volts On | CAN21-1-2 |
| 33-E | Ground | Horse Power Override HS-303 | Ground | |
| 33-F | DO-3 | Horse Power Override HS-303 | 0 Volts Off; 24 Volts On | CAN21-1-4 |
| 33-G | Ground | Load Sense Shifting HS-304 | Ground | |
| 33-H | DO-4 | Load Sense Shifting HS-304 | 0 Volts Off; 24 Volts On | CAN21-1-8 |
| 33-L | NS-2 | Node Select 2 Jumper to Ground | 0 Volts (With Jumper) | |
| 33-N | Ground | Swing Limit | Ground | |
| 33-P | DO-6 | External LMI Capacity Alarm | 0 Volts Off; 24 Volts On | CAN20-1-32 |
| 33-V | 24 Volts | Swing Limit | 24 Volts Nominal | |
| 33-W | DI-4 | Swing Limit | 0 Volts Off; 24 Volts On | CAN38-1-8 Left CAN38-1-4 Rights |
| 33-X | 24 Volts | Handle 5 and 6 (Right Travel/Left Travel) Pilot Pressure Sensor | 24 Volts Nominal | |
| 33-Z | 24 Volts | Handle 4y (Boom/Luffing Jib) Up and Down Pilot Pressure Sensor | 24 Volts Nominal | |
| 33-a | AI-1 | Handle 5 (Right Travel) Pilot Pressure Sensor | 1 Volt at 0 psi (0 bar), 5 Volts at 870 psi (60 bar) | CAN4-2 ¹ |
| 33-b | AI-2 | Handle 6 (Left Travel) Pilot Pressure Sensor | 1 Volt at 0 psi (0 bar), 5 Volts at 870 psi (60 bar) | CAN4-4 ¹ |
| 33-c | AI-3 | Handle 4y (Boom/Luffing Jib) Up Pilot Pressure Sensor | 1 Volt at 0 psi (0 bar), 5 Volts at 870 psi (60 bar) | CAN4-6 ¹ |
| 33-d | AI-4 | Handle 4y (Boom/Luffing Jib) Down Pilot Pressure Sensor | 1 Volt at 0 psi (0 bar), 5 Volts at 870 psi (60 bar) | CAN4-8 ¹ |
| 33-e | AI-5 | Handle 1 (Drum 1) Up Pilot Pressure Sensor | 1 Volt at 0 psi (0 bar), 5 Volts at 870 psi (60 bar) | CAN5-2 ¹ |
| 33-f | AI-6 | Handle 1 (Drum 1) Down Pilot Pressure Sender | 1 Volt at 0 psi (0 bar), 5 Volts at 870 psi (60 bar) | CAN5-4 ¹ |
| 33-g | Ground | Handle 5 and 6 (Right Travel/Left Travel) Pilot Pressure Sensor | Ground | |
| 33-h | Ground | Handle 4y (Boom/Luffing Jib) Up and Down Pilot Pressure Sensor | Ground | |
| 33-k | Ground | Handle 1 (Drum 1) Up and Down Pilot Pressure Sensor | Ground | |
| 33-m | Ground | Handle 2 (Drum 2) Up and Down Pilot Pressure Sensor | Ground | |
| 33-n | 24 Volts | Handle 1 (Drum 1) Up and Down Pilot Pressure Sensor | 24 Volts Nominal | |

| | | | | |
|---------------|---|---|---|----------------------|
| 33-p | AI-7 | Handle 2 (Drum 2) Up Pilot Pressure Sender | 1 Volt at 0 psi (0 bar), 5 Volts at 870 psi (60 bar) | CAN5-6 ¹ |
| 33-r | AI-8 | Handle 2 (Drum 2) Down Pilot Pressure Sensor | 1 Volt at 0 psi (0 bar), 5 Volts at 870 psi (60 bar) | CAN5-8 ¹ |
| 33-s | 24 Volts | Handle 2 (Drum 2) Up and Down Pilot Pressure Sensor | 24 Volts Nominal | |
| J4/W34 | Receptacle - Solenoids and Swing Motor Speed Sensor | | | |
| 34-A | Ground | Drum 4 Up HS-311 | Ground | |
| 34-B | DO-11 | Drum 4 Up HS-311 | 0 Volts Off; 24 Volts On | CAN21-2-4 |
| 34-C | Ground | Drum 4 Down HS-312 | Ground | |
| 34-D | DO-12 | Drum 4 Down HS-312 | 0 Volts Off; 24 Volts On | CAN21-2-8 |
| 34-E | Ground | Drum 1 Up HS-313 | Ground | |
| 34-F | DO-13 | Drum 1 Up HS-313 | 0 Volts Off; 24 Volts On | CAN21-2-16 |
| 34-G | Ground | Drum 1 Down HS-314 | Ground | |
| 34-H | DO-14 | Drum 1 Down HS-314 | 0 Volts Off; 24 Volts On | CAN21-2-32 |
| 34-J | Ground | Drum 2 Up HS-315 | Ground | |
| 34-K | Ground | Drum 3 Down HS-318 | Ground | |
| 34-L | Ground | Drum 3 Up HS-317 | Ground | |
| 34-M | DO-17 | Drum 3 Up HS-317 | 0 Volts Off; 24 Volts On | CAN21-3-1 |
| 34-N | Ground | Drum 2 Down HS-316 | Ground | |
| 34-P | DO-16 | Drum 2 Down HS-316 | 0 Volts Off; 24 Volts On | CAN21-2-128 |
| 34-R | DO-15 | Drum 2 Up HS-315 | 0 Volts Off; 24 Volts On | CAN21-2-64 |
| 34-S | DO-18 | Drum 3 Down HS-318 | 0 Volts Off; 24 Volts On | CAN21-3-2 |
| 34-T | Ground | Select Handle 3 to Drum 4 Up HS-319 | Ground | |
| 34-U | DO-19 | Select Handle 3 to Drum 4 Up HS-319 | 0 Volts Off; 24 Volts On | CAN21-3-4 |
| 34-V | Ground | Select Handle 3 to Drum 4 Down HS-320 | Ground | |
| 34-W | DO-20 | Select Handle 3 to Drum 4 Down HS-320 | 0 Volts Off; 24 Volts On | CAN21-3-8 |
| 34-X | Ground | Select Handle 4y to Drum 2 Up HS-321 | Ground | |
| 34-Z | DO-21 | Select Handle 4y to Drum 2 Up HS-321 | 0 Volts Off; 24 Volts On | CAN21-3-16 |
| 34-a | Ground | Select Handle 4y to Drum 2 Down HS-322 | Ground | |
| 34-b | DO-22 | Select Handle 4y to Drum 2 Down HS-322 | 0 Volts Off; 24 Volts On | CAN21-3-32 |
| 34-c | Ground | Select Handle 4y to Drum 3 Up HS-323 | Ground | |
| 34-d | DO-23 | Select Handle 4y to Drum 3 Up HS-323 | 0 Volts Off; 24 Volts On | CAN21-3-64 |
| 34-e | Ground | Select Handle 4y to Drum 3 Down HS-324 | Ground | |
| 34-f | DO-24 | Select Handle 4y to Drum 3 Down HS-324 | 0 Volts Off; 24 Volts On | CAN21-3-128 |
| 34-g | Ground | Jumper to Node Select 2 | Ground | |
| 34-j | NS-2 | Node Select 2 Jumper to Ground | 0 Volts (With Jumper) | |
| 34-n | 24 Volts | Swing Motor Speed Sensor | 24 Volts Nominal | |
| 34-p | EC3A | Swing Motor Speed Sensor | 1.2 or 3.2 Volts Not Moving; 2.2 Volts Moving | CAN38-3 ² |
| 34-r | Ground | Swing Motor Speed Sensor | Ground | |
| 34-s | EC3B | Swing Motor Speed Sensor | 1.2 or 3.2 Volts Not Moving; 2.2 Volts Moving | CAN38-3 ² |
| J6/W36 | Receptacle - Pressure Sensors, Limits, Speed Sensors, Mast Angle Sensor, and Motor Control | | | |
| 36-A | Ground | Swing System Left/Right Pressure Sensor | Ground | |

| | | | | |
|------|----------|--|---|-----------------------|
| 36-C | Ground | Max Boom Angle Limit/Drum 2 Motor Control | Ground | |
| 36-D | DO-8 | Drum 2 Motor Control HS-308 | 0 Volts Off; 24 Volts On | CAN21-1-128 |
| 36-E | Ground | Handle 3 Up/Down Pilot Pressure Sensor | Ground | |
| 36-F | DO-9 | Drum 1 Motor Control HS-309 | 0 Volts Off; 24 Volts On | CAN21-2-1 |
| 36-G | Ground | Drum 1 Motor Control HS-309 | Ground | |
| 36-L | NS-2 | Jumper to Node Select 2 | 0 Volts (With Jumper) | |
| 36-P | DI-7 | Max Boom Angle Limit and Mast Angle Sensor | 0 Volts Off; 24 Volts On | CAN38-1-64 |
| 36-R | 24 Volts | Swing System Left/Right Pressure Sensor | 24 Volts Nominal | |
| 36-S | 24 Volts | Max Boom Angle Limit | 24 Volts Nominal | |
| 36-T | 24 Volts | Handle 3 Up/Down Pilot Pressure Sensor | 24 Volts Nominal | |
| 36-U | Ground | Load Pin Left and Mast Angle Sensor | Ground | |
| 36-V | 5 Volts | Mast Angle Sensor | 5 Volts Nominal | |
| 36-X | 24 Volts | Load Pin Left | 24 Volts Nominal | |
| 36-Z | Ground | Handle 4x (Swing) Left/Right Pilot Pressure Sensor | Ground | |
| 36-a | AI-9 | Handle 3 Up Pilot Pressure Sensor | 1 Volt at 0 psi (0 bar), 5 Volts at 870 psi (60 bar) | CAN6-2 ¹ |
| 36-b | AI-10 | Handle 3 Down Pilot Pressure Sensor | 1 Volt at 0 psi (0 bar), 5 Volts at 870 psi (60 bar) | CAN6-4 ¹ |
| 36-c | AI-11 | Handle 4x (Swing) Left Pilot Pressure Sensor | 1 Volt at 0 psi (0 bar), 5 Volts at 870 psi (60 bar) | CAN6-6 ¹ |
| 36-d | AI-12 | Handle 4x (Swing) Right Pilot Pressure Sensor | 1 Volt at 0 psi (0 bar), 5 Volts at 870 psi (60 bar) | CAN6-8 ¹ |
| 36-e | AI-13 | Load Pin Left | 2mA (no load) to 20mA (50,000 KGs) | CAN7-2 ¹ |
| 36-f | AI-14 | Mast Angle Sensor | 0-5V 20.95mV per degree | CAN7-4 ¹ |
| 36-g | 24 Volts | Handle 4x (Swing) Left/Right Pilot Pressure Sensor | 24 Volts Nominal | |
| 36-h | AI-15 | Swing System Left Pressure Sensor | 1 Volt at 0 psi, 5 Volts at 7,000 psi | CAN7-6 ¹ |
| 36-k | AI-16 | Swing System Right Pressure Sensor | 1 Volt at 0 psi, 5 Volts at 7,000 psi | CAN7-8 ¹ |
| 36-j | Ground | Drum 1/Drum 2 Speed Sensor | Ground | |
| 36-m | 24 Volts | Drum 1/Drum 2 Speed Sensor | 24 Volts Nominal | |
| 36-n | EC1A | Drum 1 Speed Sensor | 1.2 or 3.2 Volts Not Moving; 2.2 Volts Moving | CAN37-1 ² |
| 36-p | EC1B | Drum 1 Speed Sensor | 1.2 or 3.2 Volts Not Moving; 2.2 Volts Moving | CAN37-1 ² |
| 36-r | EC-2A | Drum 2 Speed Sensor | 1.2 or 3.2 Volts Not Moving; 2.2 Volts Moving | CAN-37-3 ² |
| 36-s | EC-2B | Drum 2 Speed Sensor | 1.2 or 3.2 Volts Not Moving; 2.2 Volts Moving | CAN37-3 ² |

*1 – Lower four bits can be multiplied by 5 or 10 depending on sender, then divided by 16 for an estimation of sender voltage.

*2 – Number in indicated bank should increment in positive direction and decrement in negative direction with item rotation.

Node 4 — Swing Control, Drum Brake and Pawl Control

See Electrical Schematic 81019880, Sheets 12, 20, and 21 (at end of this section).

| Receptacle Number | Function Type | Description | Test Voltages | CAN Packet Number |
|-------------------|---|-----------------------------------|--|----------------------|
| J7-WN18 | | I/O Cable — From Node 3 to Node 4 | N/A | |
| J1-WN10 | | I/O Cable — From Node 4 to Node 0 | N/A | |
| J4/W44 | Receptacle – Drum 4, and Pump Controls | | | |
| 44-A | Ground | Travel Pilot HS-411 | Ground | |
| 44-B | DO-11 | Travel Pilot HS-411 | 0 Volts Off; 24 Volts On | CAN23-2-4 |
| 44-C | Ground | Drum 2 Brake HS-412 | Ground | |
| 44-D | DO-12 | Drum 2 Brake HS-412 | 0 Volts Off; 24 Volts On | CAN23-2-8 |
| 44-E | Ground | Drum 1 Brake HS-413 | Ground | |
| 44-F | DO-13 | Drum 1 Brake HS-413 | 0 Volts Off; 24 Volts On | CAN23-2-16 |
| 44-G | Ground | Swing Brake HS-414 | Ground | |
| 44-H | DO-14 | Swing Brake HS-414 | 0 Volts Off; 24 Volts On | CAN23-2-32 |
| 44-J | Ground | Travel High Speed HS-415 | Ground | |
| 44-K | Ground | Drum 4 Pawl Out HS-418 | Ground | |
| 44-L | Ground | Drum 3 Brake HS-417 | Ground | |
| 44-M | DO-17 | Drum 3 Brake HS-417 | 0 Volts Off; 24 Volts On | CAN23-3-1 |
| 44-N | Ground | Drum 4 Brake HS-416 | Ground | |
| 44-P | DO-16 | Drum 4 Brake HS-416 | 0 Volts Off; 24 Volts On | CAN23-2-128 |
| 44-R | DO-15 | Travel High Speed HS-415 | 0 Volts Off; 24 Volts On | CAN23-2-64 |
| 44-S | DO-18 | Drum 4 Pawl Out HS-418 | 0 Volts Off; 24 Volts On | CAN23-3-2 |
| 44-T | Ground | Drum 4 Pawl In HS-419 | Ground | |
| 44-U | DO-19 | Drum 4 Pawl In HS-419 | 0 Volts Off; 24 Volts On | CAN23-3-4 |
| 44-V | Ground | Drum 1 Pawl Out HS-420 | Ground | |
| 44-W | DO-20 | Drum 1 Pawl Out HS-420 | 0 Volts Off; 24 Volts On | CAN23-3-8 |
| 44-X | Ground | Drum 1 Pawl In HS-421 | Ground | |
| 44-Z | DO-21 | Drum 1 Pawl In HS-421 | 0 Volts Off; 24 Volts On | CAN23-3-16 |
| 44-a | Ground | Drum 3 Pawl In HS-422 | Ground | |
| 44-b | DO-22 | Drum 3 Pawl In HS-422 | 0 Volts Off; 24 Volts On | CAN23-3-32 |
| 44-c | Ground | Drum 3 Pawl Out HS-423 | Ground | |
| 44-d | DO-23 | Drum 3 Pawl Out HS-423 | 0 Volts Off; 24 Volts On | CAN23-3-64 |
| 44-e | Ground | Pilot Pressure Unloading HS-424 | Ground | |
| 44-f | DO-24 | Pilot Pressure Unloading HS-424 | 0 Volts Off; 24 Volts On | CAN23-3-128 |
| 44-g | Ground | Jumper to Node Select 4 | Ground | |
| 44-k | NS-3 | Node Select 3 Jumper to Ground | 0 Volts (With Jumper) | |
| 44-n | 24 Volts | Drum 3 Speed Sensor | 24 Volts Nominal | |
| 44-p | EC3A | Drum 3 Speed Sensor | 1.2 or 3.2 Volts Not Moving; 2.2 Volts Moving | CAN42-3 ² |
| 44-r | Ground | Drum 3 Speed Sensor | Ground | |
| 44-s | EC3B | Drum 3 Speed Sensor | 1.2 or 3.2 Volts Not Moving; 2.2 Volts Moving | CAN42-3 ² |

| J6/W46 | Receptacle – Sensors, Pressure Senders, Alarms, and Auto Lube | | | |
|--------|---|---|--|-----------------------|
| 46-A | Ground | Accessory Enable HS-407 | Ground | |
| 46-B | DO-7 | Accessory Enable HS-407 | 0 Volts Off; 24 Volts On | CAN23-1-64 |
| 46-C | Ground | Auto Grease Swing | Ground | |
| 46-D | D08 | Auto Grease Swing | 0 Volts Off; 24 Volts On | CAN23-1-128 |
| 46-E | Ground | Swing Control Right HS-409 and Drum 3 Bail Limit | Ground | |
| 46-F | DO-9 | Swing Control Right HS-409 | 0 Volts Off; 24 Volts On | CAN23-2-1 |
| 46-G | Ground | Swing Control Left HS-410 and Jumper to Node Select 3 | Ground | |
| 46-H | DO-10 | Swing Control Left HS-410 | 0 Volts Off; 24 Volts On | CAN23-2-2 |
| 46-M | NS-3 | Node Select 3 Jumper to Ground | 0 Volts (With Jumper) | |
| 46-P | DI-7 | Drum 3 Bail Limit | 0 Volts Off; 24 Volts On | CAN42-1-64 |
| 46-R | 24 Volts | Hydraulic Return Filter Alarm and Drum 3 Bail Limit | 24 Volts Nominal | |
| 46-S | 24 Volts | and Hydraulic Vacuum Set Point | 24 Volts Nominal | |
| 46-T | 24 Volts | Hydraulic Fluid Temperature Sensor | 24 Volts Nominal | |
| 46-U | Ground | Hydraulic Fluid Temperature/Level Sensor | Ground | |
| 46-m | 24 Volts | Drum 4 Speed Sensor and Pilot Filter Alarm | 24 Volts Nominal | |
| 46-Z | Ground | Drum 4 Speed Sensor | Ground | |
| 46-a | AI-9 | Hydraulic Return Filter Alarm | 0 Volts Off; 24 Volts On | CAN14-2-16 |
| 46-b | AI-10 | Hydraulic Vacuum Set Point | 0 Volts Off; 24 Volts On | CAN14-2-32 |
| 46-c | AI-11 | Hydraulic Fluid Temperature Sensor | 21V (-55 degrees C) to .14V (155 degrees C) | CAN14-6 ¹ |
| 46-d | AI-12 | Hydraulic Fluid Level Sensor | 1V (Empty) 4V (Full) | CAN14-8 ¹ |
| 46-e | AI-13 | Pilot Filter Alarm Pressure Sensor | 0 Volts Off; 24 Volts On | CAN15-2 ¹ |
| 46-f | A1-14 | Drum 1 Pressure Memory | 1 Volt 0 psi (0 bar) | CAN 15-4 ¹ |
| 46-k | A1-16 | Drum 2 Pressure Memory | 5 Volts 1,800 psi (124 bar) | CAN 15-8 ¹ |
| 46-g | 24 Volts | Ambient Air Temperature Sensor | 24 Volts Nominal | |
| 46-h | AI-15 | Ambient Air Temperature Sensor | 3.5V (-40 degrees C) to 8.94V (125 degrees C) | CAN15-6 ¹ |
| 46-j | Ground | Ambient Air Temperature Sensor | Ground | |
| 46-r | EC-2A | Drum 4 Speed Sensor | 1.2 or 3.2 Volts Not Moving; 2.2 Volts Moving | CAN41-3 ² |
| 46-s | EC-2B | Drum 4 Speed Sensor | 1.2 or 3.2 Volts Not Moving; 2.2 Volts Moving | CAN41-3 ² |

*1 – Lower four bits can be multiplied by 5 or 10 depending on sender, then divided by 16 for an estimation of sender voltage.

*2 – Number in indicated bank should increment in positive direction and decrement in negative direction with item rotation.

Node 5 — Accessories

See Electrical Schematic 81019880, Sheets 13, 14, 20, and 22 (at end of this section).

| Receptacle Number | Function Type | Description | Test Voltages | CAN Packet Number |
|-------------------|---|---|--|----------------------|
| J1-WN10 | | I/O Cable — From Engine Node | N/A | |
| J3/W53 | Receptacle – Accessories | | | |
| 53-A | Ground | Right Side Swing Travel Alarm | Ground | |
| 53-B | DO-1 | Right Side Swing Travel Alarm | 0 Volts Off; 24 Volts On | CAN24-1-1 |
| 53-C | Ground | Accessory Pump Pressure Control HS-502 | Ground | |
| 53-D | DO-2 | Accessory Pump Pressure Control HS-502 | 0 Volts Off; 24 Volts On | CAN24-1-2 |
| 53-E | Ground | Node Select 4 Jumper to Ground | Ground | |
| 53-F | DO-3 | Accessory Pump Displacement Control HS-503 | 0 Volts Off; 24 Volts On | CAN49-6 ¹ |
| 53-G | Ground | Cooler Fan Pump Controls HS-504 and Accessory Pump Displacement Control HS-503 | Ground | |
| 53-H | DO-4 | Cooler Fan Pump Controls HS-504 | 0 Volts Off; 24 Volts On | CAN49-8 ¹ |
| 53-J | Ground | Drum 1/Drum 2 Minimum Bail Limit Switch | Ground | |
| 53-N | Ground | Rigging Winch Pay In/Out | Ground | |
| 53-P | DO-5 | Rigging Winch Pay Out HS-505 | 0 Volts Off; 24 Volts On | CAN24-1-16 |
| 53-R | DO-6 | Rigging Winch Pay In HS-506 | 0 Volts Off; 24 Volts On | CAN24-1-32 |
| 53-S | NS-4 | Node Select 4 Jumper to Ground | 0 Volts (With Jumper) | |
| 53-T | DI-3 | Drum 1 Minimum Bail Limit Switch | 0 Volts Off; 24 Volts On | CAN44-1-4 |
| 53-U | 24 Volts | Drum 1 Minimum Bail Limit Switch | 24 Volts Nominal | |
| 53-V | 24 Volts | Drum 2 Minimum Bail Limit Switch | 24 Volts Nominal | |
| 53-W | DI-4 | Drum 2 Minimum Bail Limit Switch | 0 Volts Off; 24 Volts On | CAN44-1-8 |
| 53-X | 24 Volts | Accessory Pressure Sensor | 24 Volts Nominal | |
| 53-Z | 24 Volts | Engine Fuel Level Sensor | 24 Volts Nominal | |
| 53-a | AI-1 | Engine Fuel Level Sensor | 1 Volt Empty 9 Volts Full | CAN16-2 ¹ |
| 53-b | AI-2 | Load Pin Right | 2mA (no load) to 20mA (50,000 KGs) | CAN16-4 ¹ |
| 53-c | AI-3 | Cooler Fan Pressure Sensor | 1 Volt at 0 psi, 5 Volts at 7,000 psi | CAN16-6 ¹ |
| 53-d | AI-4 | Accessory Pressure Sensor | 1 Volt at 0 psi, 5 Volts at 7,000 psi | CAN16-8 ¹ |
| 53-g | Ground | Engine Fuel Level Sensor | Ground | |
| 53-h | Ground | Accessory Pressure Sensor | Ground | |
| 53-k | Ground | Cooler Fan Pressure Sensor | Ground | |
| 53-m | Ground | Load Pin Right | Ground | |
| 53-n | 24 Volts | Load Pin Right | 24 Volts Nominal | |
| 53-s | 24 Volts | Cooler Fan Pressure Sensor | 24 Volts Nominal | |
| J4/W54 | Receptacle – Accessory Pressure, Fuel Level Sensor, Left Load Pin, Rigging Winch | | | |
| 54-A | Ground | Counterweight Pins In HS-511 | Ground | |
| 54-B | DO-11 | Counterweight Pins In HS-511 | 0 Volts Off; 24 Volts On | CAN24-2-4 |
| 54-C | Ground | Counterweight Pins Out HS-512 | Ground | |

| | | | | |
|---------------|---|--|--------------------------|-------------|
| 54-D | DO-12 | Counterweight Pins Out HS-512 | 0 Volts Off; 24 Volts On | CAN24-2-8 |
| 54-E | Ground | Counterweight Cylinder Left Up HS-513 | Ground | |
| 54-F | DO-13 | Counterweight Cylinder Left Up HS-513 | 0 Volts Off; 24 Volts On | CAN24-2-16 |
| 54-G | Ground | Counterweight Cylinder Left Down HS-514 | Ground | |
| 54-H | DO-14 | Counterweight Cylinder Left Down HS-514 | 0 Volts Off; 24 Volts On | CAN24-2-32 |
| 54-J | Ground | Cab Tilt Cylinder Up HS-515 | Ground | |
| 54-K | Ground | Cab Cylinder Tilt Down HS-518 | Ground | |
| 54-L | Ground | Counterweight Cylinder Right Up HS-517 | Ground | |
| 54-M | DO-17 | Counterweight Cylinder Right Up HS-517 | 0 Volts Off; 24 Volts On | CAN24-3-1 |
| 54-N | Ground | Counterweight Cylinder Right Down HS-516 | Ground | |
| 54-P | DO-16 | Counterweight Cylinder Right Down HS-516 | 0 Volts Off; 24 Volts On | CAN24-2-128 |
| 54-R | DO-15 | Cab Tilt Cylinder Up HS-515 | 0 Volts Off; 24 Volts On | CAN24-2-64 |
| 54-S | DO-18 | Cab Cylinder Tilt Down HS-518 | 0 Volts Off; 24 Volts On | CAN24-3-2 |
| 54-T | Ground | Boom Hinge Pins In HS-519 | Ground | |
| 54-U | DO-19 | Boom Hinge Pins In HS-519 | 0 Volts Off; 24 Volts On | CAN24-3-4 |
| 54-V | Ground | Boom Hinge Pins Out HS-520 | Ground | |
| 54-W | DO-20 | Boom Hinge Pins Out HS-520 | 0 Volts Off; 24 Volts On | CAN24-3-8 |
| 54-X | Ground | Assembly Cylinder Retract (up) HS-521 | Ground | |
| 54-Z | DO-21 | Assembly Cylinder Retract (up) HS-521 | 0 Volts Off; 24 Volts On | CAN24-3-16 |
| 54-a | Ground | Assembly Cylinder Extend (down) HS-522 | Ground | |
| 54-b | DO-22 | Assembly Cylinder Extend (down) HS-522 | 0 Volts Off; 24 Volts On | CAN24-3-32 |
| 54-c | Ground | Mast Raise Cylinder Extend HS-523 | Ground | |
| 54-d | DO-23 | Mast Raise Cylinder Extend HS-523 | 0 Volts Off; 24 Volts On | CAN24-3-64 |
| 54-e | Ground | Mast Raise Cylinder Retract HS-524 | Ground | |
| 54-f | DO-24 | Mast Raise Cylinder Retract HS-524 | 0 Volts Off; 24 Volts On | CAN24-3-128 |
| 54-g | Ground | Node Select 4 Jumper to Ground | Ground | |
| 54-m | NS-4 | Node Select 4 Jumper to Ground | 0 Volts (With Jumper) | |
| J6/W56 | Receptacle – Free Fall Flange Encoders, Free Fall Enable | | | |
| 56-A | Ground | Free Fall Drum 1 Enable HS-507 | Ground | |
| 56-B | DO-7 | Free Fall Drum 1 Enable HS-507 | 0 Volts Off; 24 Volts On | CAN24-1-64 |
| 56-C | Ground | Free Fall Drum 2 Enable HS-508 | Ground | |
| 56-D | DO-8 | Free Fall Drum 2 Enable HS-508 | 0 Volts Off; 24 Volts On | CAN24-1-128 |
| 56-H | DO-10 | Emergency Stop (Remote) | 24 Volts Nominal | CAN24-2-2 |
| 56-J | DI-8 | Right Counterweight Cylinder Retract (Remote) | 0 Volts Off; 24 Volts On | CAN44-1-128 |
| 56-N | NS-4 | Node Select 4 Jumper to Ground | 0 Volts (With Jumper) | |
| 56-P | DI-7 | Counterweight Pins Extend (Remote) | 0 Volts Off; 24 Volts On | CAN44-1-64 |
| 56-T | 24 Volts | Drum 1 Free Fall Flange Encoder | 24 Volts Nominal | |
| 56-U | Ground | Drum 1 Free Fall Flange Encoder | Ground | |
| 56-W | Ground | Node Select 4 Jumper to Ground | Ground | |
| 56-a | AI-9 | Left Counterweight Cylinder Retract (Remote) | 0 Volts Off; 24 Volts On | CAN18-2-16 |
| 56-b | AI-10 | Left Counterweight Cylinder Extend (Remote) | 0 Volts Off; 24 Volts On | CAN18-2-32 |
| 56-c | AI-11 | Emergency Stop (Remote) | 0 Volts Off; 24 Volts On | CAN18-2-64 |
| 56-d | AI-12 | Counterweight Pins Disengage (Remote) | 0 Volts Off; 24 Volts On | CAN18-2-128 |
| 56-e | AI-13 | Counterweight Pins/Boom Hinge Pins Engage (Remote) | 0 Volts Off; 24 Volts On | CAN19-2-16 |

| | | | | |
|------|----------|---------------------------------|--|-------------|
| 56-f | AI-14 | Boom Hinge Pins Disengage | 0 Volts Off; 24 Volts On | CAN19-2-32 |
| 56-g | 24 Volts | Drum 2 Free Fall Flange Encoder | 24 Volts Nominal | |
| 56-h | AI-15 | Mast Cylinders Extend (Remote) | 0 Volts Off; 24 Volts On | CAN19-2-64 |
| 56-j | Ground | Drum 2 Free Fall Flange Encoder | Ground | |
| 56-k | AI-16 | Mast Cylinders Retract (Remote) | 0 Volts Off; 24 Volts On | CAN19-2-128 |
| 56-n | EC-1A | Drum 1 Free Fall Flange Encoder | < 2 Volts Not Over Gear Tooth; > 24 Volts Over Gear Tooth | CAN43-2 *2 |
| 56-p | EC-1B | Drum 1 Free Fall Flange Encoder | < 2 Volts Not Over Gear Tooth; > 24 Volts Over Gear Tooth | CAN43-2 *2 |
| 56-r | EC-2A | Drum 2 Free Fall Flange Encoder | < 2 Volts Not Over Gear Tooth; > 24 Volts Over Gear Tooth | CAN43-3 *2 |
| 56-s | EC-2B | Drum 2 Free Fall Flange Encoder | < 2 Volts Not Over Gear Tooth; > 24 Volts Over Gear Tooth | CAN43-3 *2 |

*1 – Lower four bits can be multiplied by 5 or 10 depending on sender, then divided by 16 for an estimation of sender voltage.

*2 – Number in indicated bank should increment in positive direction and decrement in negative direction with item rotation.

Boom Remote Input Node 30

See Electrical Schematic 81019880, Sheet 27 and 28 (at end of this section).

| Receptacle/ RIN ID | Wire No. | Description | Test Voltage |
|-----------------------|--|--------------------------|---------------------------|
| J1 | Receptacle – Input/Output | | |
| 301A | P1A | System Power | 12 Volts Nominal |
| 301B | P1B | Data Out | Variable 0 to 12 Volts |
| 301C | P1C | System Ground | Ground |
| J2 | Receptacle – Input/Output to Wind Speed RIN | | |
| 302A | P5A | System Power | 12 Volts Nominal |
| 302B | P5B | Data In | Variable 0 to 12 Volts |
| 302C | P5C | System Ground | Ground |
| J3 | Receptacle – Boom Items | | |
| 303G | P6WT | Block-Up Limit 1 - Lower | 0 Volts Off; 12 Volts On |
| 303E | P6BK | Block-Up Limit 1 - Lower | CAN84-2-128 |
| 303N | P9WT | Block-Up Limit 2 - Upper | 0 Volts Off; 12 Volts On |
| 303H | P9BK | Block-Up Limit 2 - Upper | CAN84-2-64 |
| 303P | P3WT | Block-Up Limit 3 - Fixed | 0 Volts Off; 12 Volts On |
| 303L | P3BK | Block-Up Limit 3 - Fixed | CAN84-4-128 |
| 303B | P4WT | Maximum Jib Angle Limit | 10 Volts Off; 12 Volts On |
| 303A | P4GN | Maximum Jib Angle Limit | CAN84-4-64 |
| 303C | P5C | Maximum Jib Angle Limit | Ground |
| 303B | P4WT | Minimum Jib Angle Limit | 10 Volts Off; 12 Volts On |
| 303K | P2BK | Minimum Jib Angle Limit | CAN84-4-32 |
| 303C | P5C | Minimum Jib Angle Limit | Ground |
| 303R | P8BN | Wind Speed Sensor | 2 to 20 Micro Amps |
| 303M | P8WT | Wind Speed Sensor | AC 1 |
| 303S | P8BK | Wind Speed Sensor | Ground |
| P | Receptacle – Angle Sensor | | |
| P10 | P10 | Boom Angle Sensor | Ground |
| P11 | P11 | Boom Angle Sensor | AR 1 |
| P12 | P12 | Boom Angle Sensor | 5 Volts Nominal |

Luffing Jib Remote Input Node 31

See Electrical Schematic 81019880, Sheet 27 and 28 (at end of this section).

| Receptacle/ RIN ID | Wire No. | Description | Test Voltage |
|-----------------------|---|------------------|--------------------------|
| J1 | Receptacle – Input/Output | | |
| 311A | P1A | System Power | 12 Volts Nominal |
| 311B | P1B | Data Out | Variable 0 to 12 Volts |
| 311C | P1C | System Ground | Ground |
| J2 | Receptacle – Input/Output to Wind Speed RIN 32 | | |
| 312A | P5A | System Power | 12 Volts Nominal |
| 312B | P5B | Data In | Variable 0 to 12 Volts |
| 312C | P5C | System Ground | Ground |
| J3 | Receptacle – Boom Items | | |
| 313G | P6WT | Block-Up Limit 4 | 0 Volts Off; 12 Volts On |
| 313E | P6BK | Block-Up Limit 4 | CAN-85-2-128 |
| 313N | P9WT | Block-Up Limit 3 | 0 Volts Off; 12 Volts On |
| 313H | P9BK | Block-Up Limit 3 | CAN-85-2-64 |
| 313J | P7BN | Load Sensor 3 | 12 Volt Nominal |
| 313D | P7WT | Load Sensor 3 | AC 2 |
| 313F | P7BK | Load Sensor 3 | Ground |
| 313R | P8BN | Load Sensor 4 | 12 Volts Nominal |
| 313M | P8WT | Load Sensor 4 | AC 1 |
| 313S | P8BK | Load Sensor 4 | Ground |
| P | Receptacle – Angle Sensor | | |
| P10 | P10 | Jib Angle Sensor | Ground |
| P11 | P11 | Jib Angle Sensor | AR 1 |
| P12 | P12 | Jib Angle Sensor | 5 Volts Nominal |

Node 0 — Engine

See Electrical Schematic 81019880, Sheet 16 (at end of this section).

| Receptacle/ Pin No. | Wire No. | Function Type | Description |
|------------------------|--|------------------|------------------------------------|
| J1 | Battery Power | | |
| J1-A | 0 | Ground | Battery Ground |
| J1-B | 6 - 1 | 24 Volts | Battery Power |
| J2 | Engine Control | | |
| J2-A | 0 | Ground | Battery Ground |
| J2-B | 6C6 | 24 Volts | ECM Power |
| J2-C | 6C6 | 24 Volts | ECM Power |
| J2-D | 0 | Ground | Battery Ground |
| J2-E | 6C7A | 24 Volts | MS1 Relay - Switched |
| J2-F | 6C7A | 24 Volts | MS1 Relay - Switched |
| J2-G | 0 | Ground | Battery Ground |
| J2-H | 6C2A | 24 Volts | ECM Key Switch - Switched |
| J2-J | 6C5A | 24 Volts | Air Conditioning Clutch - Switched |
| J2-V | J1939H | Signal | Communication - High |
| J2-W | J1939L | Signal | Communication - Low |
| J2-Y | J1939S | Ground | Battery Ground |
| J3 | CAN Bus Communication and Power | | |
| J3-A | 8C | 24 Volts | CAN Bus Power - Switched |
| J3-C | CANH | Signal | CAN Communications - High |
| J3-D | 0C | Ground | CAN Bus Ground - Switched |
| J3-F | CANL | Signal | CAN Communications - Low |
| J4 | CAN Bus Communication and Power | | |
| J4-A | 8C | 24 Volts | CAN Bus Power - Switched |
| J4-C | CANH | Signal | CAN Communications - High |
| J4-D | 0C | Ground | CAN Bus Ground - Switched |
| J4-F | CANL | Signal | CAN Communications - Low |
| J5 | operator cab | | |
| J5-A | 8 | 24 Volts | CAB Power - Switched |
| J5-B | 6C4 | 24 Volts | Key Switch Power |
| J5-C | 6C4 | 24 Volts | Key Switch Power |
| J5-D | 0 | Ground | Battery Ground |
| J5-E | 3 | Signal | Key Switch Signal |
| J5-F | 12F2 | 24 Volts | Boom Node Power |
| J6 | Cummins Engine Diagnostics | | |
| J6-A | 0 | Ground | Battery Ground |
| J6-B | 6C3 | 24 Volts | Cummins Diagnostic Power |
| J6-C | J1939H | Signal | SAE J1939 Communication - High |
| J6-D | J1939L | Signal | SAE J1939 Communication - Low |
| J6-E | J1939S | Ground | SAE J1939 Communication - Shield |
| J7 | Program Download | | |
| J7-1 | RS232TX | Signal | RS232 Program Transmit |

| | | | |
|-----------|----------------------------|-----------|---|
| J7-2 | RS232RX | Signal | RS232 Program Receive |
| J7-3 | RS232PE | Signal | RS232 Program Enable |
| J7-4 | RS232GND | Ground | RS232 Program Ground |
| J8 | Boom Cable | | |
| J8-A | 12F2 | 24 Volts | Boom Node Power |
| J8-B | 0126 | DI Signal | Boom Node Digital Input |
| J8-C | 0 | Ground | Battery Ground |
| P1 | Receptacle – 40 Pin | | |
| P1-1 | 3 | 24 Volts | Ignition Signal |
| P1-2 | 0102 | Ground | CAN Bus Ground Relay Coil - High |
| P1-4 | 0104 | 24 Volts | ECM Key Switch Relay Coil - High |
| P1-7 | 0107 | 24 Volts | Air Conditioning Clutch Relay Coil - High |
| P1-10 | 0110 | Ground | MS1 Relay Coil - High |
| P1-11 | 0 | Ground | Battery Ground |
| P1-12 | 0112 | Ground | CAN BUS Relay Coil - Low |
| P1-14 | 0114 | Ground | ECM Key Switch Relay Coil - Low |
| P1-17 | 0117 | Ground | Air Conditioning Clutch Relay Coil - Low |
| P1-20 | 0120 | Ground | MS1 Relay Coil - Low |
| P1-21 | OC | Ground | CAN BUS Ground - Switched |
| P1-22 | 0122 | Ground | CAN BUS Power Relay Coil - Low |
| P1-26 | 0126 | DO Signal | Boom Node |
| P1-29 | RS232GND | Ground | Program Ground |
| P1-30 | RS232PE | Signal | Program Enable |
| P1-31 | 8C | 24 Volts | CAN BUS Power - Switched |
| P1-32 | 0132 | 24 Volts | CAN BUS Power Relay Coil - High |
| P1-33 | 3 | 24 Volts | Battery Power |
| P1-36 | J1939H | Signal | SAE J1939 Communication – High |
| P1-37 | J1939L | Signal | SAE J1939 Communication – Low |
| P1-39 | RS232TX | Signal | Program Transmit |
| P1-40 | RS232RX | Signal | Program Receive |

Table 3-4. Digital Input Reference

| CAN Packet Number | Item Description (Node Number) | CAN Packet Number | Item Description (Node Number) |
|-------------------|---|-------------------|--|
| CAN36-1-1 | Free Fall Safety Switch Left Pedal | CAN92-3-8 | Drum 0 Park Switch |
| CAN36-1-2 | Self Assembly Cylinder Retract | CAN92-3-16 | Rear Drum (Drum 2) Park Switch (N1) |
| CAN36-1-4 | Self Assembly Cylinder Extend | CAN92-3-64 | Travel Park Switch (N1) |
| CAN36-1-8 | Free Fall Safety Switch Right Pedal | CAN92-3-128 | Mast Cylinders Retract Switch (N1) |
| CAN36-1-16 | Air Conditioning - On (N2) | CAN92-4-1 | Display Enter Switch (N1) |
| CAN36-1-32 | Cab Tilt - Down (N2) | CAN92-4-2 | Confirm Switch (N1) |
| CAN36-1-128 | Seat Safety Switch (N2) | CAN92-4-4 | Limit Bypass Switch (N1) |
| CAN36-2-16 | Cab Tilt - Up (N2) | CAN92-4-8 | Display Scroll Up Switch (N1) |
| CAN36-2-32 | Drum Speed | CAN92-4-32 | Display Scroll Down Switch (N1) |
| CAN36-2-64 | Travel Speed (N2) | CAN92-4-128 | Free Fall Enable Switch Drum 1 |
| CAN38-1-14 | Swing Limit Right | CAN92-5-1 | Boom Hinge Pins Disengage |
| CAN38-1-8 | Swing Limit Left | CAN92-5-2 | Mast Cylinders Extend Switch |
| CAN38-1-64 | Max Boom Angle Limit | CAN92-5-4 | DPF Regen Inhibit (N1) |
| CAN44-1-4 | Drum 1 Minimum Bail Limit Switch | CAN 92-5-16 | DPF Regen Initiate (N1) |
| CAN44-1-8 | Drum 2 Minimum Bail Limit Switch | CAN92-5-32 | Engine Run/Start (N1) |
| CAN44-1-64 | Counterweight Pins Extend (Remote) | CAN92-5-128 | Boom Hoist (Drum 4) Park Switch |
| CAN44-1-128 | Right Counterweight Cylinder Retract (Remote) | CAN92-6-2 | Free Fall Enable Switch Drum 2 |
| CAN84-2-64 | Block-Up Limit 2 - Upper Point (N20) | CAN92-6-4 | Display 1 (N1) |
| CAN84-2-128 | Block-Up Limit 1- Lower Point (N20) | CAN92-6-16 | Display 2 (N1) |
| CAN84-4-32 | Minimum Jib Angle Limit (N20) | CAN92-6-32 | Swing Park Switch |
| CAN84-4-64 | Maximum Jib Angle Limit (N20) | CAN92-6-64 | Display Exit Switch (N1) |
| CAN84-4-128 | Block-Up Limit 3 - Fixed (N20) | CAN92-6-128 | Load/Luffing (Drum 3) Park Switch (N1) |
| CAN85-2-64 | Block-Up Limit 3 (N21) | CAN113-4-32 | Boom Shorting Plug |
| CAN85-2-128 | Block-Up Limit 4 (N21) | | |
| CAN92-3-4 | Front Drum (Drum 1) Park Switch (N1) | | |

Table 3-5. Digital Output Reference

| CAN Packet Number | Item Description (Node Number) | CAN Packet Number | Item Description (Node Number) |
|-------------------|--|-------------------|--|
| CAN20-1-1 | RCI Beacon Light Green | CAN23-2-4 | Travel Pilot HS-411 |
| CAN20-1-128 | Seat Safety Switch | CAN23-2-64 | Travel High Speed HS-415 |
| CAN20-1-16 | RCI Beacon – Light Red | CAN23-2-8 | Drum 2 Brake HS-412 |
| CAN20-1-2 | Drum 4 Handle (H4) Rotation Indicator | CAN23-3-1 | Drum 3 Brake HS-417 |
| CAN20-1-32 | Drum 3 Handle (H3) Rotation Indicator | CAN23-3-128 | Pilot Pressure Unloading HS-424 |
| CAN20-1-4 | Drum 2 Handle (H2) Rotation Indicator | CAN23-3-16 | Drum 1 Pawl In HS-421 |
| CAN20-1-64 | Drum 1 Handle (H1) Rotation Indicator | CAN23-3-2 | Drum 4 Pawl Out HS-418 |
| CAN20-1-8 | RCI Beacon Light Amber | CAN23-3-32 | Drum 3 Pawl In HS-422 |
| CAN20-2-1 | Cab Tilt, Drum Speed, Travel Speed Switches | CAN23-3-4 | Drum 4 Pawl In HS-419 |
| CAN20-2-128 | Engine Oil Pressure | CAN23-3-64 | Drum 3 Pawl Out HS-423 |
| CAN20-2-16 | Engine Coolant Temperature | CAN23-3-8 | Drum 1 Pawl Out HS-420 |
| CAN20-2-8 | Self Assembly Cylinder | CAN24-1-1 | Right Side Swing Travel Alarm |
| CAN20-3-128 | Rated Capacity Indicator/Limiter Fault Alarm | CAN24-1-128 | Free Fall Drum 2 (Rear) Enable HS-508 |
| CAN20-3-2 | Switch - Boom Hinge Pins | CAN24-1-16 | Rigging Winch Pay Out HS-505 |
| CAN20-3-32 | System Operation Alarm | CAN24-1-2 | Lower Accessories HS-502 |
| CAN20-3-4 | Handle 4y Swing Holding Brake Switch | CAN24-1-32 | Rigging Winch Pay In HS-506 |
| CAN20-3-64 | Foot Throttle | CAN24-1-64 | Free Fall Drum 1 (Front) Enable HS-507 |
| CAN20-3-8 | Engine Fuel Level | CAN24-2-128 | Counterweight Cylinder Right Down HS-516 |
| CAN21-1-1 | Left Side Swing/Travel Alarm | CAN24-2-16 | Counterweight Cylinder Left Up HS-513 |
| CAN21-1-128 | Drum 1 Motor Control HS-308 | CAN24-2-2 | Emergency Stop (Remote) |
| CAN21-1-2 | Main Valve Combined Flow Control HS-302 | CAN24-2-32 | Counterweight Cylinder Left Down HS-514 |
| CAN21-1-4 | Horse Power Override HS-303 | CAN24-2-4 | Counterweight Pins In HS-511 |
| CAN21-1-8 | Load Sense Shifting HS-304 | CAN24-2-64 | Cab Tilt Cylinder Up HS-515 |
| CAN21-2-1 | Drum 2 Motor Control HS-309 | CAN24-2-8 | Counterweight Pins Out HS-512 |
| CAN21-2-128 | Drum 2 Down HS-316 | CAN24-3-1 | Counterweight Cylinder Right Up HS-517 |
| CAN21-2-16 | Drum 1 Up HS-313 | CAN24-3-128 | Mast Raise Cylinder Retract HS-524 |
| CAN21-2-32 | Drum 1 Down HS-314 | CAN24-3-16 | Assembly Cylinder Retract HS-521 |
| CAN21-2-4 | Drum 4 Up HS-311 | CAN24-3-2 | Cab Cylinder Tilt Down HS-518 |
| CAN21-2-64 | Drum 2 Up HS-315 | CAN24-3-32 | Assembly Cylinder Extend HS-522 |
| CAN21-2-8 | Drum 4 Down HS-312 | CAN24-3-4 | Boom Hinge Pins In HS-519 |
| CAN21-3-1 | Drum 3 Up HS-317 | CAN24-3-64 | Mast Raise Cylinder Extend HS-523 |
| CAN21-3-128 | Select Handle 4y to Drum 3 Down HS-324 | CAN24-3-8 | Boom Hinge Pins Out HS-520 |
| CAN21-3-16 | Select Handle 4y to Drum 2 Up HS-321 | CAN92-1-16 | Free Fall Enable LED Drum 2 |
| CAN21-3-2 | Drum 3 Down HS-318 | CAN92-1-2 | Free Fall Enable Switch |
| CAN21-3-32 | Select Handle 4y to Drum 2 Down HS-322 | CAN92-1-32 | RCL Caution L.E.D. |
| CAN21-3-4 | Select Handle 3 to Drum 4 Up HS-319 | CAN92-1-4 | RCL Warning L.E.D. |
| CAN21-3-64 | Select Handle 4y to Drum 3 Up HS-323 | CAN92-1-64 | Free Fall Enable LED Drum 1 |
| CAN21-3-8 | Select Handle 3 to Drum 4 Down HS-320 | CAN92-2-1 | Limit Bypass/Swing Park Switch |
| CAN32-1-128 | Auto Lube Swing | CAN92-2-128 | Drum 0,4, and Travel Park Switches |
| CAN23-2-32 | Swing Brake HS-414 | CAN92-2-2 | Overhead Panel |
| CAN23-2-1 | Swing Control Right HS-409 | CAN92-2-4 | Drums 1, 2, and 3 Park Switches |
| CAN23-2-128 | Drum 4 Brake HS-416 | | |
| CAN23-2-16 | Drum 1 Brake HS-413 | | |
| CAN23-2-2 | Swing Control Left HS-410 | | |

Table 3-6. Digital Output Disable Reference

| CAN Packet Number | Item Description (Node Number) | CAN Packet Number | Item Description (Node Number) |
|-------------------|--|-------------------|--|
| CAN30-1-1 | RCI Beacon Light Green | | |
| CAN30-1-128 | Seat Safety Switch | CAN33-2-1 | Swing Control Right HS-409 |
| CAN30-1-16 | RCI Beacon – Light Red | CAN33-2-128 | Drum 4 Brake HS-416 |
| CAN30-1-2 | Drum 4 Handle (H4) Rotation Indicator | CAN33-2-16 | Drum 1 Brake HS-413 |
| CAN30-1-32 | Drum 3 Handle (H3) Rotation Indicator | CAN33-2-2 | Swing Control Left HS-410 |
| CAN30-1-4 | Drum 2 Handle (H2) Rotation Indicator | CAN33-2-32 | Swing Brake HS-414 |
| CAN30-1-64 | Drum 1 Handle (H1) Rotation Indicator | CAN33-2-4 | Travel Pilot HS-411 |
| CAN30-1-8 | RCI Beacon Light Amber | CAN33-2-64 | Travel High Speed HS-415 |
| CAN30-2-1 | Cab Tilt, Drum Speed, Travel Speed Switches | CAN33-2-8 | Drum 2 Brake HS-412 |
| CAN30-2-128 | Engine Oil Pressure | CAN33-3-1 | Drum 3 Brake HS-417 |
| CAN30-2-16 | Engine Coolant Temperature | CAN33-3-128 | Pilot Pressure Unloading HS-424 |
| CAN30-2-8 | Self Assembly Cylinder | CAN33-3-16 | Drum 1 Pawl In HS-421 |
| CAN30-3-128 | Rated Capacity Indicator/Limiter Fault Alarm | CAN33-3-2 | Drum 4 Pawl Out HS-418 |
| CAN30-3-2 | Switch - Boom Hinge Pins | CAN33-3-32 | Drum 3 Pawl In HS-422 |
| CAN30-3-32 | System Operation Alarm | CAN33-3-4 | Drum 4 Pawl In HS-419 |
| CAN30-3-4 | Handle 4y Swing Holding Brake Switch | CAN33-3-64 | Drum 3 Pawl Out HS-423 |
| CAN30-3-64 | Foot Throttle | CAN33-3-8 | Drum 1 Pawl Out HS-420 |
| CAN30-3-8 | Engine Fuel Level | CAN34-1-1 | Right Side Swing Travel Alarm |
| CAN31-1-1 | Left Side Swing/Travel Alarm | CAN34-1-128 | Free Fall Drum 2 Enable HS-508 |
| CAN31-1-128 | Drum 1 Motor Control HS-308 | CAN34-1-16 | Rigging Winch Pay Out HS-505 |
| CAN31-1-2 | Main Valve Combined Flow Control HS-302 | CAN34-1-2 | Lower Accessories HS-502 |
| CAN31-1-4 | Horse Power Override HS-303 | CAN34-1-32 | Rigging Winch Pay In HS-506 |
| CAN31-1-8 | Load Sense Shifting HS-304 | CAN34-1-64 | Free Fall Drum 1 Enable HS-507 |
| CAN31-2-1 | Drum 2 Motor Control HS-309 | | |
| CAN31-2-128 | Drum 2 Down HS-316 | CAN34-2-128 | Counterweight Cylinder Right Down HS-516 |
| CAN31-2-16 | Drum 1 Up HS-313 | CAN34-2-16 | Counterweight Cylinder Left Up HS-513 |
| CAN31-2-32 | Drum 1 Down HS-314 | CAN34-2-2 | Emergency Stop (Remote) |
| CAN31-2-4 | Drum 4 Up HS-311 | CAN34-2-32 | Counterweight Cylinder Left Down HS-514 |
| CAN31-2-64 | Drum 2 Up HS-315 | CAN34-2-4 | Counterweight Pins In HS-511 |
| CAN31-2-8 | Drum 4 Down HS-312 | CAN34-2-64 | Cab Tilt Cylinder Up HS-515 |
| CAN31-3-1 | Drum 3 Up HS-317 | CAN34-2-8 | Counterweight Pins Out HS-512 |
| CAN31-3-128 | Select Handle 4y to Drum 3 Down HS-324 | CAN34-3-1 | Counterweight Cylinder Right Up HS-517 |
| CAN31-3-16 | Select Handle 4y to Drum 2 Up HS-321 | CAN34-3-128 | Mast Raise Cylinder Retract HS-524 |
| CAN31-3-2 | Drum 3 Down HS-318 | CAN34-3-16 | Assembly Cylinder Retract HS-521 |
| CAN31-3-32 | Select Handle 4y to Drum 2 Down HS-322 | CAN34-3-2 | Cab Cylinder Tilt Down HS-518 |
| CAN31-3-4 | Select Handle 3 to Drum 4 Up HS-319 | CAN34-3-32 | Assembly Cylinder Extend HS-522 |
| CAN31-3-64 | Select Handle 4y to Drum 3 Up HS-323 | CAN34-3-4 | Boom Hinge Pins In HS-519 |
| CAN31-3-8 | Select Handle 3 to Drum 4 Down HS-320 | CAN34-3-64 | Mast Raise Cylinder Extend HS-523 |
| CAN33-1-128 | Auto Lube Swing | CAN34-3-8 | Boom Hinge Pins Out HS-520 |

Table 3-7. Bank Identifiers

| | 1 | 2 | 4 | 8 | 16 | 32 | 64 | 128 |
|----|---|---|---|---|----|----|----|-----|
| 1 | | | | | | | | |
| 2 | | | | | | | | |
| 3 | | | | | | | | |
| 4 | | | | | | | | |
| 5 | | | | | | | | |
| 6 | | | | | | | | |
| 7 | | | | | | | | |
| 8 | | | | | | | | |
| 9 | | | | | | | | |
| 10 | | | | | | | | |
| 11 | | | | | | | | |
| 12 | | | | | | | | |
| 13 | | | | | | | | |
| 14 | | | | | | | | |
| 15 | | | | | | | | |
| 16 | | | | | | | | |
| 17 | | | | | | | | |
| 18 | | | | | | | | |
| 19 | | | | | | | | |
| 20 | | | | | | | | |
| 21 | | | | | | | | |
| 22 | | | | | | | | |
| 23 | | | | | | | | |
| 24 | | | | | | | | |
| 25 | | | | | | | | |
| 26 | | | | | | | | |
| 27 | | | | | | | | |
| 28 | | | | | | | | |
| 29 | | | | | | | | |
| 30 | | | | | | | | |
| 31 | | | | | | | | |
| 32 | | | | | | | | |
| 33 | | | | | | | | |
| 34 | | | | | | | | |
| 35 | | | | | | | | |
| 36 | | | | | | | | |
| 37 | | | | | | | | |
| 38 | | | | | | | | |
| 39 | | | | | | | | |
| 40 | | | | | | | | |
| 41 | | | | | | | | |
| 42 | | | | | | | | |
| 43 | | | | | | | | |

| | 1 | 2 | 4 | 8 | 16 | 32 | 64 | 128 |
|----|---|---|---|---|----|----|----|-----|
| 44 | | | | | | | | |
| 45 | | | | | | | | |
| 46 | | | | | | | | |
| 47 | | | | | | | | |
| 48 | | | | | | | | |
| 49 | | | | | | | | |
| 50 | | | | | | | | |
| 51 | | | | | | | | |
| 52 | | | | | | | | |
| 53 | | | | | | | | |
| 54 | | | | | | | | |
| 55 | | | | | | | | |
| 56 | | | | | | | | |
| 57 | | | | | | | | |
| 58 | | | | | | | | |
| 59 | | | | | | | | |
| 60 | | | | | | | | |
| 61 | | | | | | | | |
| 62 | | | | | | | | |
| 63 | | | | | | | | |
| 64 | | | | | | | | |
| 65 | | | | | | | | |
| 66 | | | | | | | | |
| 67 | | | | | | | | |
| 68 | | | | | | | | |
| 69 | | | | | | | | |
| 70 | | | | | | | | |
| 71 | | | | | | | | |
| 72 | | | | | | | | |
| 73 | | | | | | | | |
| 74 | | | | | | | | |
| 75 | | | | | | | | |
| 76 | | | | | | | | |
| 77 | | | | | | | | |
| 78 | | | | | | | | |
| 79 | | | | | | | | |
| 80 | | | | | | | | |
| 81 | | | | | | | | |
| 82 | | | | | | | | |
| 83 | | | | | | | | |
| 84 | | | | | | | | |
| 85 | | | | | | | | |
| 86 | | | | | | | | |

| | 1 | 2 | 4 | 8 | 16 | 32 | 64 | 128 |
|-----|---|---|---|---|----|----|----|-----|
| 87 | | | | | | | | |
| 88 | | | | | | | | |
| 89 | | | | | | | | |
| 90 | | | | | | | | |
| 91 | | | | | | | | |
| 92 | | | | | | | | |
| 93 | | | | | | | | |
| 94 | | | | | | | | |
| 95 | | | | | | | | |
| 96 | | | | | | | | |
| 97 | | | | | | | | |
| 98 | | | | | | | | |
| 99 | | | | | | | | |
| 100 | | | | | | | | |
| 101 | | | | | | | | |
| 102 | | | | | | | | |
| 103 | | | | | | | | |
| 104 | | | | | | | | |
| 105 | | | | | | | | |
| 106 | | | | | | | | |
| 107 | | | | | | | | |
| 108 | | | | | | | | |
| 109 | | | | | | | | |
| 110 | | | | | | | | |
| 111 | | | | | | | | |
| 112 | | | | | | | | |
| 113 | | | | | | | | |
| 114 | | | | | | | | |
| 115 | | | | | | | | |
| 116 | | | | | | | | |
| 117 | | | | | | | | |
| 118 | | | | | | | | |
| 119 | | | | | | | | |
| 120 | | | | | | | | |
| 121 | | | | | | | | |
| 122 | | | | | | | | |
| 123 | | | | | | | | |
| 124 | | | | | | | | |
| 125 | | | | | | | | |
| 126 | | | | | | | | |
| 127 | | | | | | | | |
| 128 | | | | | | | | |
| 129 | | | | | | | | |

Table 3-7. Bank Identifiers (continued)

| | 1 | 2 | 4 | 8 | 16 | 32 | 64 | 128 |
|-----|---|---|---|---|----|----|----|-----|
| 130 | | | | | | | | |
| 131 | | | | | | | | |
| 132 | | | | | | | | |
| 133 | | | | | | | | |
| 134 | | | | | | | | |
| 135 | | | | | | | | |
| 136 | | | | | | | | |
| 137 | | | | | | | | |
| 138 | | | | | | | | |
| 139 | | | | | | | | |
| 140 | | | | | | | | |
| 141 | | | | | | | | |
| 142 | | | | | | | | |
| 143 | | | | | | | | |
| 144 | | | | | | | | |
| 145 | | | | | | | | |
| 146 | | | | | | | | |
| 147 | | | | | | | | |
| 148 | | | | | | | | |
| 149 | | | | | | | | |
| 150 | | | | | | | | |
| 151 | | | | | | | | |
| 152 | | | | | | | | |
| 153 | | | | | | | | |
| 154 | | | | | | | | |
| 155 | | | | | | | | |
| 156 | | | | | | | | |
| 157 | | | | | | | | |
| 158 | | | | | | | | |
| 159 | | | | | | | | |
| 160 | | | | | | | | |
| 161 | | | | | | | | |
| 162 | | | | | | | | |
| 163 | | | | | | | | |
| 164 | | | | | | | | |
| 165 | | | | | | | | |
| 166 | | | | | | | | |
| 167 | | | | | | | | |
| 168 | | | | | | | | |
| 169 | | | | | | | | |
| 170 | | | | | | | | |
| 171 | | | | | | | | |
| 172 | | | | | | | | |

| | 1 | 2 | 4 | 8 | 16 | 32 | 64 | 128 |
|-----|---|---|---|---|----|----|----|-----|
| 173 | | | | | | | | |
| 174 | | | | | | | | |
| 175 | | | | | | | | |
| 176 | | | | | | | | |
| 177 | | | | | | | | |
| 178 | | | | | | | | |
| 179 | | | | | | | | |
| 180 | | | | | | | | |
| 181 | | | | | | | | |
| 182 | | | | | | | | |
| 183 | | | | | | | | |
| 184 | | | | | | | | |
| 185 | | | | | | | | |
| 186 | | | | | | | | |
| 187 | | | | | | | | |
| 188 | | | | | | | | |
| 189 | | | | | | | | |
| 190 | | | | | | | | |
| 191 | | | | | | | | |
| 192 | | | | | | | | |
| 193 | | | | | | | | |
| 194 | | | | | | | | |
| 195 | | | | | | | | |
| 196 | | | | | | | | |
| 197 | | | | | | | | |
| 198 | | | | | | | | |
| 199 | | | | | | | | |
| 200 | | | | | | | | |
| 201 | | | | | | | | |
| 202 | | | | | | | | |
| 203 | | | | | | | | |
| 204 | | | | | | | | |
| 205 | | | | | | | | |
| 206 | | | | | | | | |
| 207 | | | | | | | | |
| 208 | | | | | | | | |
| 209 | | | | | | | | |
| 210 | | | | | | | | |
| 211 | | | | | | | | |
| 212 | | | | | | | | |
| 213 | | | | | | | | |
| 214 | | | | | | | | |
| 215 | | | | | | | | |

| | 1 | 2 | 4 | 8 | 16 | 32 | 64 | 128 |
|-----|---|---|---|---|----|----|----|-----|
| 216 | | | | | | | | |
| 217 | | | | | | | | |
| 218 | | | | | | | | |
| 219 | | | | | | | | |
| 220 | | | | | | | | |
| 221 | | | | | | | | |
| 222 | | | | | | | | |
| 223 | | | | | | | | |
| 224 | | | | | | | | |
| 225 | | | | | | | | |
| 226 | | | | | | | | |
| 227 | | | | | | | | |
| 228 | | | | | | | | |
| 229 | | | | | | | | |
| 230 | | | | | | | | |
| 231 | | | | | | | | |
| 232 | | | | | | | | |
| 233 | | | | | | | | |
| 234 | | | | | | | | |
| 235 | | | | | | | | |
| 236 | | | | | | | | |
| 237 | | | | | | | | |
| 238 | | | | | | | | |
| 239 | | | | | | | | |
| 240 | | | | | | | | |
| 241 | | | | | | | | |
| 242 | | | | | | | | |
| 243 | | | | | | | | |
| 244 | | | | | | | | |
| 245 | | | | | | | | |
| 246 | | | | | | | | |
| 247 | | | | | | | | |
| 248 | | | | | | | | |
| 249 | | | | | | | | |
| 250 | | | | | | | | |
| 251 | | | | | | | | |
| 252 | | | | | | | | |
| 253 | | | | | | | | |
| 254 | | | | | | | | |
| 255 | | | | | | | | |

Table 3-7. Bank Identifiers (continued)

| | 1 | 2 | 4 | 8 | 16 | 32 | 64 | 128 | 256 |
|-----|---|---|---|---|----|----|----|-----|-----|
| 256 | | | | | | | | | |
| 257 | | | | | | | | | |
| 258 | | | | | | | | | |
| 259 | | | | | | | | | |
| 260 | | | | | | | | | |
| 261 | | | | | | | | | |
| 262 | | | | | | | | | |
| 263 | | | | | | | | | |
| 264 | | | | | | | | | |
| 265 | | | | | | | | | |
| 266 | | | | | | | | | |
| 267 | | | | | | | | | |
| 268 | | | | | | | | | |
| 269 | | | | | | | | | |
| 270 | | | | | | | | | |
| 271 | | | | | | | | | |
| 272 | | | | | | | | | |
| 273 | | | | | | | | | |
| 274 | | | | | | | | | |
| 275 | | | | | | | | | |
| 276 | | | | | | | | | |
| 277 | | | | | | | | | |
| 278 | | | | | | | | | |
| 279 | | | | | | | | | |
| 280 | | | | | | | | | |
| 281 | | | | | | | | | |
| 282 | | | | | | | | | |
| 283 | | | | | | | | | |
| 284 | | | | | | | | | |
| 285 | | | | | | | | | |
| 286 | | | | | | | | | |
| 287 | | | | | | | | | |
| 288 | | | | | | | | | |
| 289 | | | | | | | | | |
| 290 | | | | | | | | | |
| 291 | | | | | | | | | |
| 292 | | | | | | | | | |
| 293 | | | | | | | | | |
| 294 | | | | | | | | | |
| 295 | | | | | | | | | |
| 296 | | | | | | | | | |
| 297 | | | | | | | | | |
| 298 | | | | | | | | | |

| | 1 | 2 | 4 | 8 | 16 | 32 | 64 | 128 | 256 |
|-----|---|---|---|---|----|----|----|-----|-----|
| 299 | | | | | | | | | |
| 300 | | | | | | | | | |
| 301 | | | | | | | | | |
| 302 | | | | | | | | | |
| 303 | | | | | | | | | |
| 304 | | | | | | | | | |
| 305 | | | | | | | | | |
| 306 | | | | | | | | | |
| 307 | | | | | | | | | |
| 308 | | | | | | | | | |
| 309 | | | | | | | | | |
| 310 | | | | | | | | | |
| 311 | | | | | | | | | |
| 312 | | | | | | | | | |
| 313 | | | | | | | | | |
| 314 | | | | | | | | | |
| 315 | | | | | | | | | |
| 316 | | | | | | | | | |
| 317 | | | | | | | | | |
| 318 | | | | | | | | | |
| 319 | | | | | | | | | |
| 320 | | | | | | | | | |
| 321 | | | | | | | | | |
| 322 | | | | | | | | | |
| 323 | | | | | | | | | |
| 324 | | | | | | | | | |
| 325 | | | | | | | | | |
| 326 | | | | | | | | | |
| 327 | | | | | | | | | |
| 328 | | | | | | | | | |
| 329 | | | | | | | | | |
| 330 | | | | | | | | | |
| 331 | | | | | | | | | |
| 332 | | | | | | | | | |
| 333 | | | | | | | | | |
| 334 | | | | | | | | | |
| 335 | | | | | | | | | |
| 336 | | | | | | | | | |
| 337 | | | | | | | | | |
| 338 | | | | | | | | | |
| 339 | | | | | | | | | |
| 340 | | | | | | | | | |
| 341 | | | | | | | | | |

| | 1 | 2 | 4 | 8 | 16 | 32 | 64 | 128 | 256 |
|-----|---|---|---|---|----|----|----|-----|-----|
| 342 | | | | | | | | | |
| 343 | | | | | | | | | |
| 344 | | | | | | | | | |
| 345 | | | | | | | | | |
| 346 | | | | | | | | | |
| 347 | | | | | | | | | |
| 348 | | | | | | | | | |
| 349 | | | | | | | | | |
| 350 | | | | | | | | | |
| 351 | | | | | | | | | |
| 352 | | | | | | | | | |
| 353 | | | | | | | | | |
| 354 | | | | | | | | | |
| 355 | | | | | | | | | |
| 356 | | | | | | | | | |
| 357 | | | | | | | | | |
| 358 | | | | | | | | | |
| 359 | | | | | | | | | |
| 360 | | | | | | | | | |
| 361 | | | | | | | | | |
| 362 | | | | | | | | | |
| 363 | | | | | | | | | |
| 364 | | | | | | | | | |
| 365 | | | | | | | | | |
| 366 | | | | | | | | | |
| 367 | | | | | | | | | |
| 368 | | | | | | | | | |
| 369 | | | | | | | | | |
| 370 | | | | | | | | | |
| 371 | | | | | | | | | |
| 372 | | | | | | | | | |
| 373 | | | | | | | | | |
| 374 | | | | | | | | | |
| 375 | | | | | | | | | |
| 376 | | | | | | | | | |
| 377 | | | | | | | | | |
| 378 | | | | | | | | | |
| 379 | | | | | | | | | |
| 380 | | | | | | | | | |
| 381 | | | | | | | | | |
| 382 | | | | | | | | | |
| 383 | | | | | | | | | |
| 384 | | | | | | | | | |

Table 3-7. Bank Identifiers (continued)

| | 1 | 2 | 4 | 8 | 16 | 32 | 64 | 128 | 256 |
|-----|---|---|---|---|----|----|----|-----|-----|
| 385 | | | | | | | | | |
| 386 | | | | | | | | | |
| 387 | | | | | | | | | |
| 388 | | | | | | | | | |
| 389 | | | | | | | | | |
| 390 | | | | | | | | | |
| 391 | | | | | | | | | |
| 392 | | | | | | | | | |
| 393 | | | | | | | | | |
| 394 | | | | | | | | | |
| 395 | | | | | | | | | |
| 396 | | | | | | | | | |
| 397 | | | | | | | | | |
| 398 | | | | | | | | | |
| 399 | | | | | | | | | |
| 400 | | | | | | | | | |
| 401 | | | | | | | | | |
| 402 | | | | | | | | | |
| 403 | | | | | | | | | |
| 404 | | | | | | | | | |
| 405 | | | | | | | | | |
| 406 | | | | | | | | | |
| 407 | | | | | | | | | |
| 408 | | | | | | | | | |
| 409 | | | | | | | | | |
| 410 | | | | | | | | | |
| 411 | | | | | | | | | |
| 412 | | | | | | | | | |
| 413 | | | | | | | | | |
| 414 | | | | | | | | | |
| 415 | | | | | | | | | |
| 416 | | | | | | | | | |
| 417 | | | | | | | | | |
| 418 | | | | | | | | | |
| 419 | | | | | | | | | |
| 420 | | | | | | | | | |
| 421 | | | | | | | | | |
| 422 | | | | | | | | | |
| 423 | | | | | | | | | |
| 424 | | | | | | | | | |
| 425 | | | | | | | | | |
| 426 | | | | | | | | | |
| 427 | | | | | | | | | |

| | 1 | 2 | 4 | 8 | 16 | 32 | 64 | 128 | 256 |
|-----|---|---|---|---|----|----|----|-----|-----|
| 428 | | | | | | | | | |
| 429 | | | | | | | | | |
| 430 | | | | | | | | | |
| 431 | | | | | | | | | |
| 432 | | | | | | | | | |
| 433 | | | | | | | | | |
| 434 | | | | | | | | | |
| 435 | | | | | | | | | |
| 436 | | | | | | | | | |
| 437 | | | | | | | | | |
| 438 | | | | | | | | | |
| 439 | | | | | | | | | |
| 440 | | | | | | | | | |
| 441 | | | | | | | | | |
| 442 | | | | | | | | | |
| 443 | | | | | | | | | |
| 444 | | | | | | | | | |
| 445 | | | | | | | | | |
| 446 | | | | | | | | | |
| 447 | | | | | | | | | |
| 448 | | | | | | | | | |
| 449 | | | | | | | | | |
| 450 | | | | | | | | | |
| 451 | | | | | | | | | |
| 452 | | | | | | | | | |
| 453 | | | | | | | | | |
| 454 | | | | | | | | | |
| 455 | | | | | | | | | |
| 456 | | | | | | | | | |
| 457 | | | | | | | | | |
| 458 | | | | | | | | | |
| 459 | | | | | | | | | |
| 460 | | | | | | | | | |
| 461 | | | | | | | | | |
| 462 | | | | | | | | | |
| 463 | | | | | | | | | |
| 464 | | | | | | | | | |
| 465 | | | | | | | | | |
| 466 | | | | | | | | | |
| 467 | | | | | | | | | |
| 468 | | | | | | | | | |
| 469 | | | | | | | | | |
| 470 | | | | | | | | | |

| | 1 | 2 | 4 | 8 | 16 | 32 | 64 | 128 | 256 |
|-----|---|---|---|---|----|----|----|-----|-----|
| 471 | | | | | | | | | |
| 472 | | | | | | | | | |
| 473 | | | | | | | | | |
| 474 | | | | | | | | | |
| 475 | | | | | | | | | |
| 476 | | | | | | | | | |
| 477 | | | | | | | | | |
| 478 | | | | | | | | | |
| 479 | | | | | | | | | |
| 480 | | | | | | | | | |
| 481 | | | | | | | | | |
| 482 | | | | | | | | | |
| 483 | | | | | | | | | |
| 484 | | | | | | | | | |
| 485 | | | | | | | | | |
| 486 | | | | | | | | | |
| 487 | | | | | | | | | |
| 488 | | | | | | | | | |
| 489 | | | | | | | | | |
| 490 | | | | | | | | | |
| 491 | | | | | | | | | |
| 492 | | | | | | | | | |
| 493 | | | | | | | | | |
| 494 | | | | | | | | | |
| 495 | | | | | | | | | |
| 496 | | | | | | | | | |
| 497 | | | | | | | | | |
| 498 | | | | | | | | | |
| 499 | | | | | | | | | |
| 500 | | | | | | | | | |
| 501 | | | | | | | | | |
| 502 | | | | | | | | | |
| 503 | | | | | | | | | |
| 504 | | | | | | | | | |
| 505 | | | | | | | | | |
| 506 | | | | | | | | | |
| 507 | | | | | | | | | |
| 508 | | | | | | | | | |
| 509 | | | | | | | | | |
| 510 | | | | | | | | | |

SECTION 4 BOOM

TABLE OF CONTENTS

| | |
|---|------|
| Automatic Boom Stop | 4-1 |
| Automatic Boom Stop Maintenance | 4-1 |
| Automatic Boom Stop Adjustment | 4-3 |
| Automatic Boom Stop Actuator Rod Replacement | 4-3 |
| Physical Boom Stop | 4-5 |
| Physical Boom Stop Angles | 4-5 |
| Physical Boom Stop Operation | 4-5 |
| Physical Boom Stop Adjustment | 4-5 |
| Boom and Luffing Jib Angle Indicator | 4-6 |
| Mast Angle Sending Unit | 4-7 |
| Adjusting Mast Angle | 4-7 |
| Strap Inspection and Maintenance | 4-8 |
| Inspection | 4-8 |
| Frequent Inspection | 4-8 |
| Periodic Inspection | 4-8 |
| Cranes Not In Regular Use | 4-8 |
| Identifying Straps | 4-8 |
| Replacement Specifications | 4-9 |
| Corrosion or Abrasion | 4-9 |
| Straightness | 4-10 |
| Flatness | 4-10 |
| Elongated Hole | 4-11 |
| Strap Length | 4-11 |
| Storing Straps | 4-11 |
| Removing Straps from Service | 4-12 |
| Inspection Checklist | 4-12 |
| Lattice Section Inspection and Lacing Replacement | 4-15 |

Reference Only

THIS PAGE INTENTIONALLY LEFT BLANK

SECTION 4

BOOM

AUTOMATIC BOOM STOP

The automatic boom stop limit switch assembly (1, [Figure 4-1](#)) automatically stops the boom (2) and applies the boom hoist brake if the boom is raised to the maximum boom angle (3).

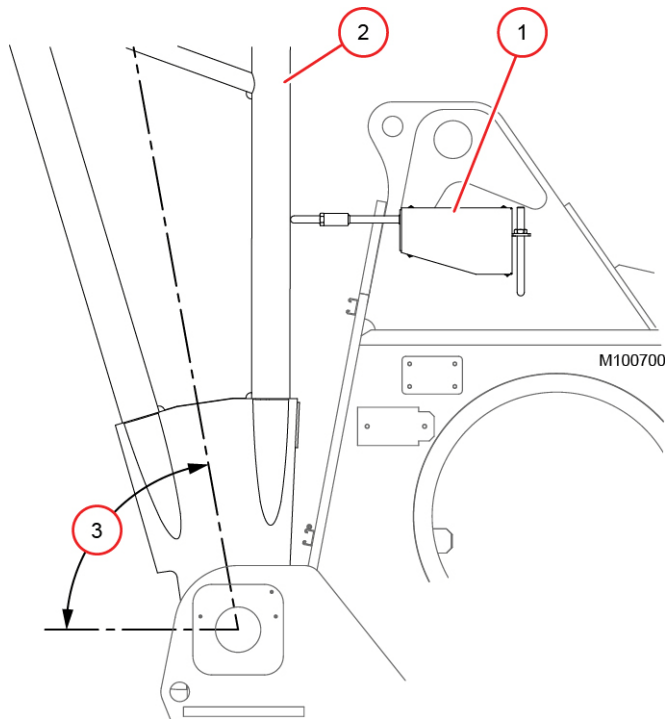

| Item | Description |
|------|--|
| 1 | Limit Switch Assembly |
| 2 | Boom Butt |
| 3 | Maximum boom angle: 82.7° without Luffing Jib 88.0° with Luffing Jib |

Figure 4-1



WARNING Falling Attachment Hazard

Do not operate the crane unless the automatic boom stop is properly adjusted and operational. Do not adjust the maximum operating angle higher than specified. The boom could be pulled over backwards or collapse, causing death or serious injury.

When the maximum boom angle is reached, the fault alarm comes on and the boom maximum up icon appears in the information screen of the main display.

To correct the fault once it is activated, lower the boom. The fault cannot be bypassed.



Automatic Boom Stop Maintenance

At least once weekly, check that the automatic boom stop stops the boom at the specified maximum boom angle. If it doesn't, replace any worn or damaged parts and/or adjust the automatic boom stop.

The automatic boom stop angle must be readjusted each time the luffing jib is installed or removed.

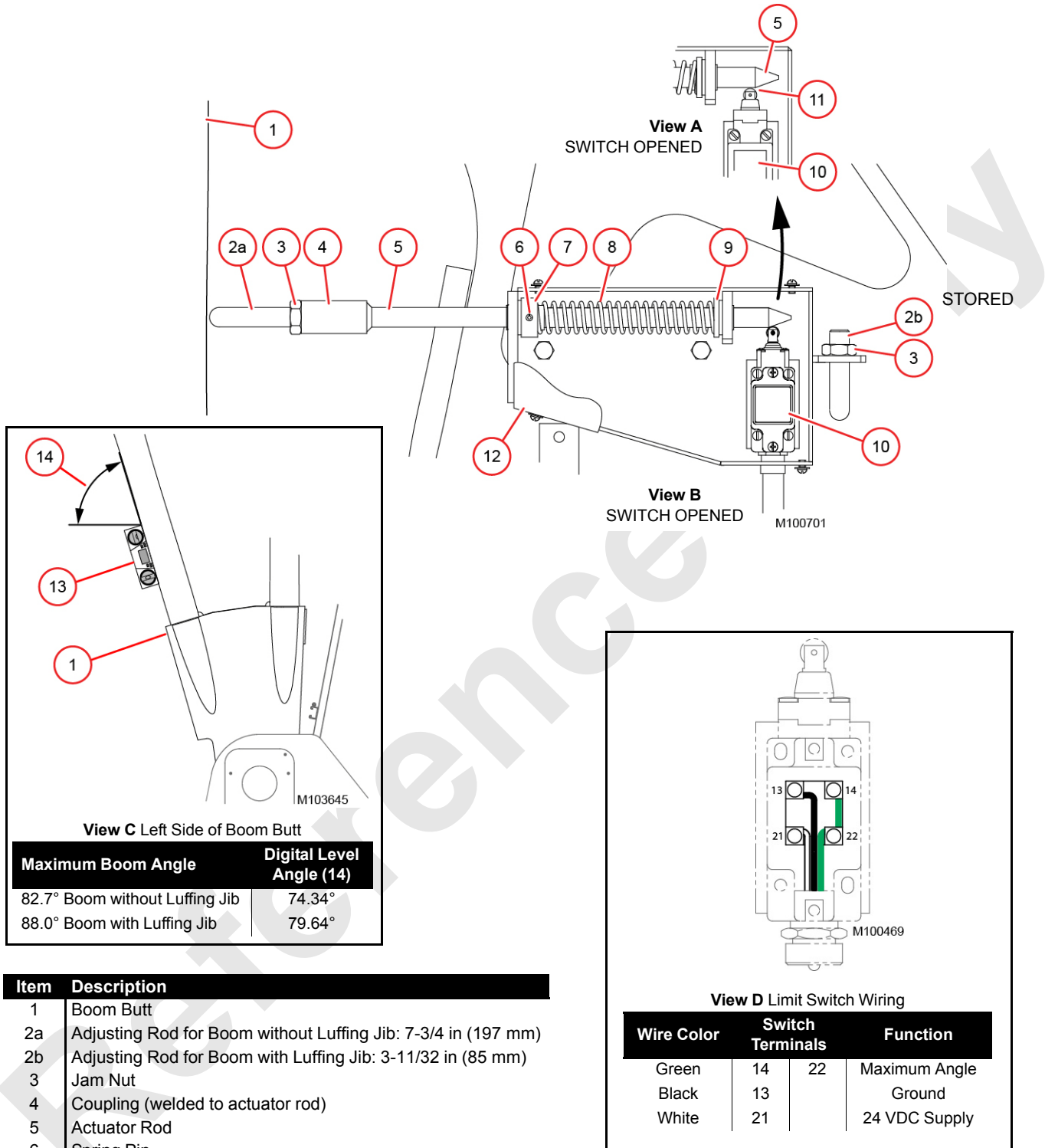

| Maximum Boom Angle | Digital Level Angle (14) |
|--------------------------------|--------------------------|
| 82.7° Boom without Luffing Jib | 74.34° |
| 88.0° Boom with Luffing Jib | 79.64° |

| Item | Description |
|------|---|
| 1 | Boom Butt |
| 2a | Adjusting Rod for Boom without Luffing Jib: 7-3/4 in (197 mm) |
| 2b | Adjusting Rod for Boom with Luffing Jib: 3-11/32 in (85 mm) |
| 3 | Jam Nut |
| 4 | Coupling (welded to actuator rod) |
| 5 | Actuator Rod |
| 6 | Spring Pin |
| 7 | Spring Washer |
| 8 | Spring |
| 9 | Spring Washer |
| 10 | Limit Switch |
| 11 | Over-Travel—Switch Opened |
| 12 | Cover |
| 13 | Digital Protractor-Level |
| 14 | Digital Level Angle |

Figure 4-2

Automatic Boom Stop Adjustment

See [Figure 4-2](#) for the following procedure.

The limit switch for the automatic boom stop was set at the factory and should not require periodic adjustment. Adjustment is necessary when:

- Parts are replaced
- The boom is operated with luffing jib removed
- The boom is operated with luffing jib installed

The following procedure assumes that the Rated Capacity Limiter/Indicator (RCL/RCI) is installed and properly calibrated.

During the following procedure, the boom angle is monitored on the RCL/RCI working screen and on a digital protractor-level (13, View C).

1. Park the crane on a firm level surface or level the crane by blocking under the crawlers.
2. Check that the proper adjusting rod (2a or 2b) is installed:
 - Rod (2a) for boom without luffing jib
 - Rod (2b) for boom with luffing jib
3. Boom up slowly while monitoring the boom angle on the RCL/RCI working screen.
4. Stop booming up when the boom reaches the specified maximum boom angle given in the table for View C.

Verify the boom angle with an accurate digital protractor-level (13) placed on the boom butt bottom chord as shown in View C. The specified digital level angle (14) should appear on the protractor-level.

 - If the boom stops at the specified angle, further adjustment is not needed.
 - If the boom stops before reaching the specified angle, go to step 5.
 - If the boom reaches the specified angle before it stops, go to step 6.
5. If the boom stops before reaching the specified angle:
 - a. Loosen the jam nut (3, View B).
 - b. Turn the adjusting rod (2a or 2b) all the way into the coupling (4).
 - c. Boom up slowly until the boom reaches the specified angle and stop.
 - d. Turn the adjusting rod (2a or 2b) out against the boom butt (1) until the limit switch (10) "CLICKS" open.
 - e. Tighten the jam nut (3).
6. If the boom reaches the specified angle before it stops:
 - a. Boom up slowly until the boom reaches the specified angle and stop.
 - b. Loosen the jam nut (3, View B).
 - c. Turn the adjusting rod (2a or 2b) out against the boom butt (1) until the limit switch (10) "CLICKS" open.
 - d. Tighten the jam nut (3).
7. Check that the actuator rod (6) over-travels the limit switch as shown in View A.
8. Boom down and then back up. The boom must stop at the specified maximum boom angle.
9. If the boom fails to stop, repeat [step 3](#) through [step 8](#).

Automatic Boom Stop Actuator Rod Replacement

See [Figure 4-2](#) for the following procedure.

1. Park the crane on a firm level surface or level the crane by blocking under the crawlers.
2. Remove the damaged or incorrect actuator rod (5).
3. Slide the spring washers (7 and 9) and spring (8) over the new actuator rod (5) while sliding the new actuator rod into the bracket assembly.
4. Position the actuator rod (5) so the tapered end just contacts the roller on limit switch (10). The actuator rod must not depress the limit switch roller.
5. Drill a 1/4 in (6 mm) hole through the spring washer (9) and the actuator rod (5).
6. Install the spring pin (6).
7. Install the proper adjusting rod (2a or 2b) and perform [Automatic Boom Stop Adjustment](#) procedure.

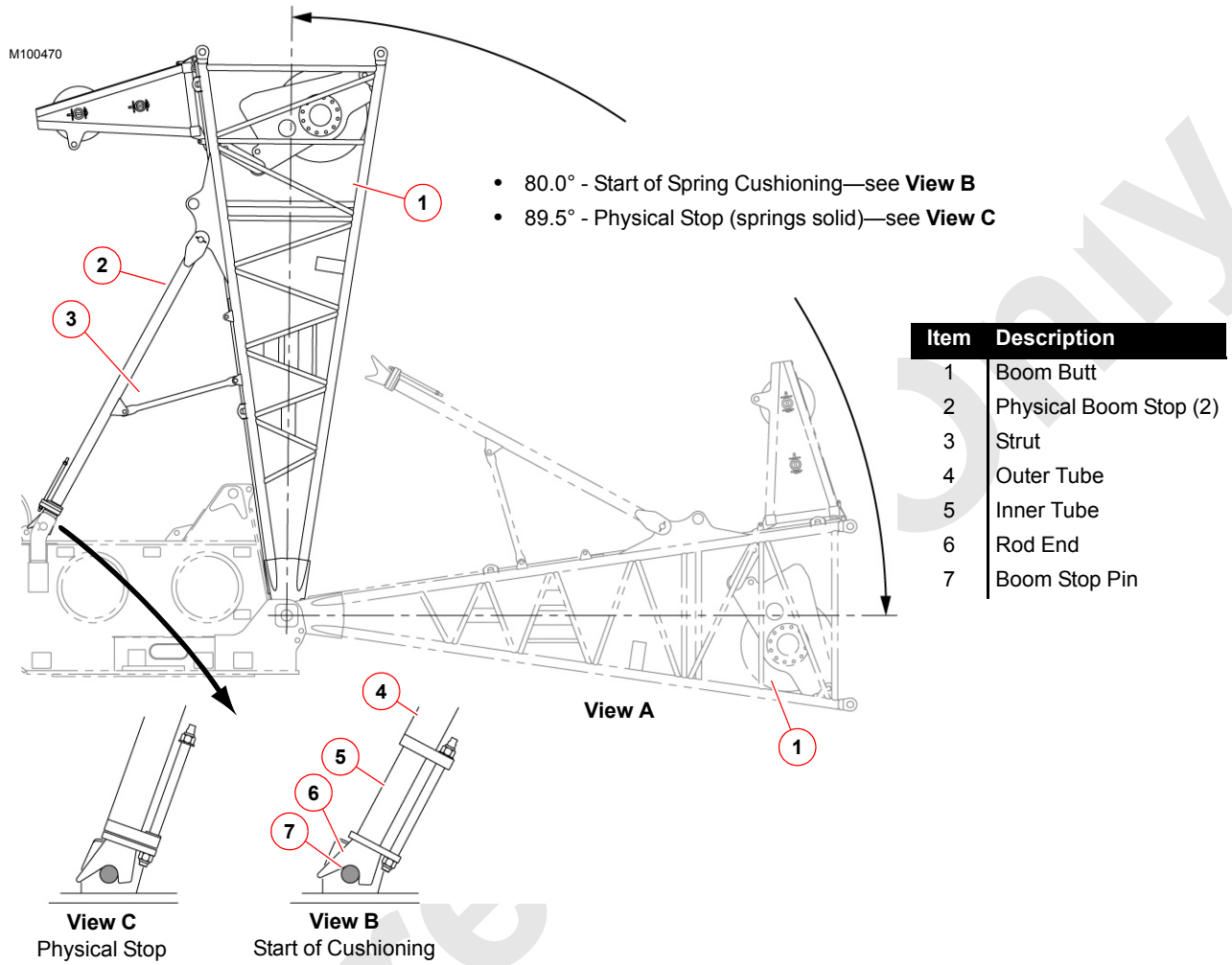

Figure 4-3

PHYSICAL BOOM STOP

See [Figure 4-3](#)



WARNING

Collapsing Boom Hazard!

Physical boom stops must be installed for all crane operations.

Physical boom stops do not automatically stop boom at maximum operating angle.

Automatic boom stop must be installed and properly adjusted.

Physical Boom Stop Angles

Physical boom stops (2, View A) serve the following purposes:

- Assist in stopping the boom smoothly at any angle above 80°

- Assist in preventing the boom rigging from pulling the boom back when traveling or setting loads with the boom at any angle above 80°
- Assist in moving the boom forward when lowering the boom from any angle above 80°
- Provide a physical stop at 89.5°

Physical Boom Stop Operation

- When the boom is raised to 80°, the springs in the boom stop tubes start to compress (View B).
- As the boom is raised higher, spring compression increases to exert greater force against the boom.
- If for any reason the boom is raised to 89.5°, the boom stop springs fully compress to provide a physical stop (View C).

Physical Boom Stop Adjustment

Struts (3) have slotted ends that do not require adjustment.

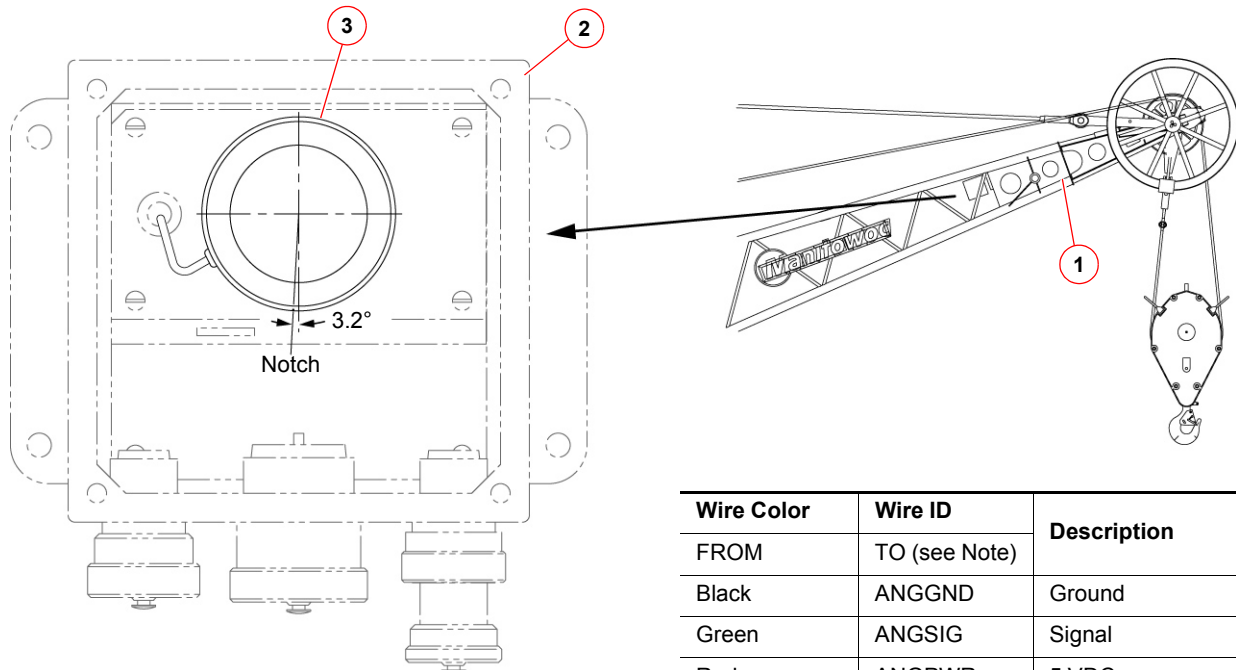

| Item | Description |
|------|-----------------|
| 1 | Luffing Jib Top |
| 2 | Controller |
| 3 | Sensor |

| Wire Color | Wire ID | Description |
|------------|---------------|-------------|
| FROM | TO (see Note) | |
| Black | ANGGND | Ground |
| Green | ANGSIG | Signal |
| Red | ANGPWR | 5 VDC |
| White | Not Used | |

NOTE Wires go to terminals on printed circuit board in bottom of controller.

Figure 4-4

BOOM AND LUFFING JIB ANGLE INDICATOR

See [Figure 4-4](#)

An angle sensor (3) is located inside the controller (2) mounted on the boom top and on the luffing jib top (1).

The boom and luffing jib angles are calibrated automatically by the crane's programmable controller as part of the load

calibration procedure for the Rated Capacity Limiter/Indicator (RCL/RCI). Refer to the RCL/RCI Operation Manual for instructions.

When installing a new sensor (3), mount it in the controller at the specified angle.

Connect the electric wires from the sensor (3) to the specified terminals on the printed circuit board in the bottom of the controller.

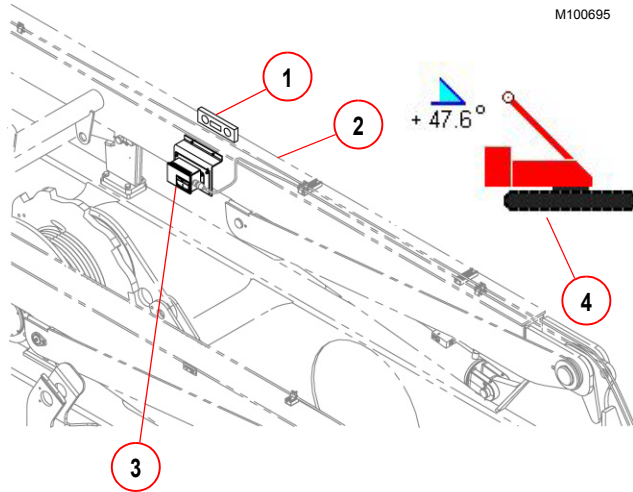

| Item | Description |
|------|--------------------------|
| 1 | Digital Protractor-Level |
| 2 | Left Mast Leg |
| 3 | Angle Sending Unit |
| 4 | Mast Angle Screen |

Figure 4-5

MAST ANGLE SENDING UNIT

The mast angle sending unit (1, [Figure 4-5](#)) was set at the factory and should not require periodic adjustment. Adjustment is required if parts are replaced.

Adjusting Mast Angle

1. Lower the mast to transport position.

2. Place a digital protractor-level (1) on the left mast leg (2) and note the mast angle.
3. Go to the mast angle readout (4) on the information screen of the main display. Note the mast angle.
4. Verify the angles noted in [step 2](#) and [step 3](#) are within 1°.
5. If necessary, loosen the mounting screws and rotate the sending unit (3) in the mounting slots until the reading on the display matches the angle displayed on the level.
6. Securely tighten the mounting screws.

STRAP INSPECTION AND MAINTENANCE

This section is a guide to crane owners for properly inspecting and maintaining straps in the field. It is impossible to predict whether or when a strap may fail. Frequent and periodic inspections can help reveal potential for failure. Straps are to be inspected regularly by a **qualified person** as part of crane's preventive maintenance program. Dated records should also be kept.

Strap repairs are prohibited. Perform only the maintenance indicated in this section. For inspection procedures not covered in this Service Manual, contact your dealer or the Manitowoc Crane Care Lattice Team.



WARNING

If strap damage was caused by overload or shock load or if there is damage to other major structural components, Manitowoc recommends that a thorough inspection be made by a qualified person. A nondestructive test of all critically stressed members must be made.

Strap connecting links are subject to the same inspection procedures and replacement specifications as those for straps. In this section, **strap** means straps and connecting links.

Inspection

Regular inspection of all straps is necessary to assure that crane safely can lift its rated load. If a strap fails, boom or other attachment can collapse. All inspections must be performed by a qualified appointed inspector at following intervals:

- Routinely on a daily (frequent inspection) or monthly (periodic inspection)
- Before initial use
- After transport
- After an overload or shock loading has occurred
- If boom and/or jib has come into contact with another object (for example, power lines, building, another crane)
- If boom or jib has been struck by lightning

Frequent Inspection

Visually inspect all straps once each work shift for obvious damage which poses an immediate hazard. Pay particular

attention to areas where wear and other damage is likely to occur. Look for straps that are disconnected, loose or sagging excessively and for distortion such as kinking or twisting. If any strap looks like it is damaged, strap must be checked to make sure it is within specifications given in this section.

Periodic Inspection

Periodic inspection must be performed at least monthly. During this inspection, entire length of strap must be inspected to assure that it is within specifications. **Strap must be within all specifications identified in this section.** Any damage found must be recorded and a determination made as to whether continued use of strap is safe.

Before beginning inspection, thoroughly clean strap of all dirt, grease, oil, etc. so a thorough inspection can be made. Closely examine those areas where paint is chipped, wrinkled, or missing and where faint rust lines or marks appear.

A qualified inspector may modify interval for periodic inspection depending on the following factors:

- Severity of environment in which crane is operated
- Size, nature, and frequency of lifts
- Exposure to shock loading or other abuse

Cranes Not In Regular Use

A qualified inspector should determine type of inspection required for cranes that have been idle. A frequent inspection (visual observation) should be adequate for a crane that has been idle for less than six months. A periodic inspection is required for cranes that have been idle for more than six months.

Identifying Straps

To aid in identification, part number is stamped into both ends of each strap as shown in [Figure 4-6](#).

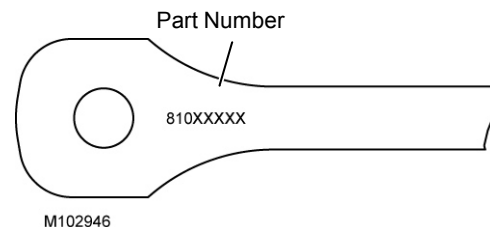

Figure 4-6

Replacement Specifications

Any strap not within specifications listed in [Table 4-1](#) must be replaced.

WARNING

If damage to strap exceeds that allowed within specification, do not operate crane until strap has been replaced.

Operating crane with a damaged strap can cause structural failure or collapse of boom, jib, mast, or other crane components.

Table 4-1 Strap Specifications

| Condition | Reference | Allowable Tolerance or Deviation | Corrective Action |
|---|--------------------------------------|------------------------------------|---|
| Dent | Figure 4-7 View A | < 3% of strap thickness | Monitor condition. |
| | | ≥ 3% of strap thickness | Remove strap from service. |
| Crack or Break | Figure 4-7 View B | None | Remove strap from service. |
| Kink | Figure 4-7 View C | None | Remove strap from service. |
| Corrosion or Abrasion | Figure 4-8 | < 3% of strap cross-sectional area | Sandblast and paint to maintain continuous protective coating. |
| | | ≥ 3% of strap cross-sectional area | Remove strap from service. |
| Straightness (gradual or sweeping bend) | Figure 4-9 | Table 4-2 | Remove strap from service if deviation exceeds maximum allowed. |
| Flatness (includes twisted straps) | Figure 4-10 | Table 4-3 | Remove strap from service if deviation exceeds maximum allowed. |
| Elongated Holes | Figure 4-11 | None | Remove strap from service. |
| Length | Figure 4-12 | None | Remove strap from service. |

< = less than
 ≥ = equal to or greater than

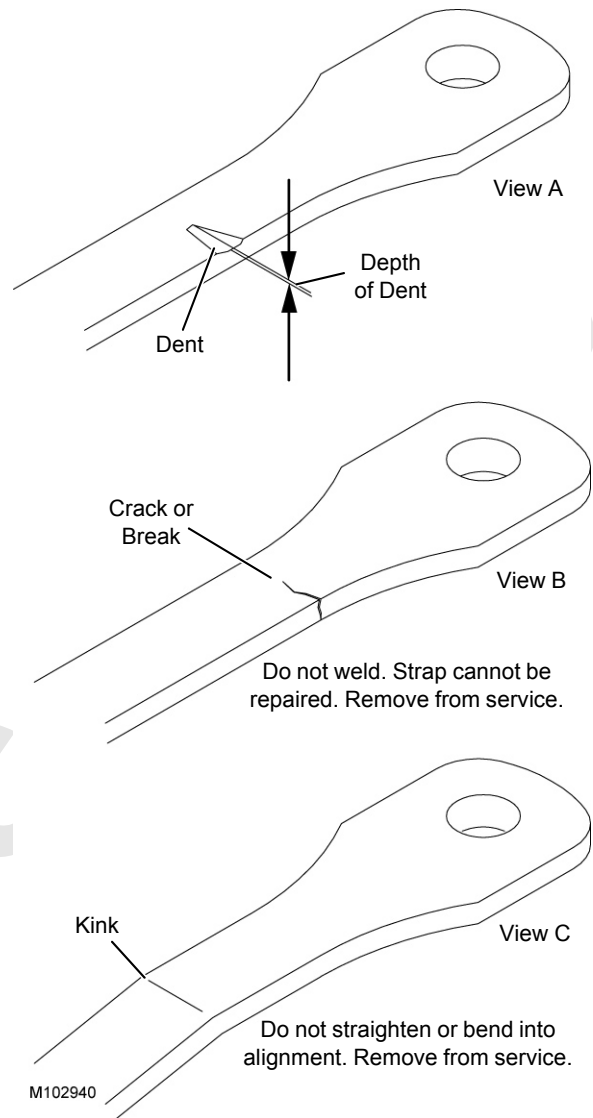

Figure 4-7

Corrosion or Abrasion

See [Figure 4-8](#) for the following procedure.

For quick identification by repair workers, clearly mark damaged areas with brightly colored tape.

1. Sandblast to remove corrosion. **Do not grind!**
2. Determine reduction in cross-sectional area.
3. If reduction is less than 3% of strap cross-sectional area, paint strap to maintain continuous protective coating.
4. If reduction is 3% or more of strap cross-sectional area, remove strap from service.

Corrosion or Abrasion

P325

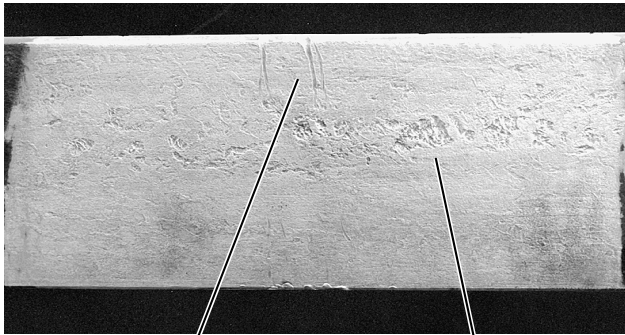

Not Acceptable
Abrasion from handling with chain exceeds allowable limit.

Not Acceptable
Surface is badly pitted; exceeds allowable limit.

P326

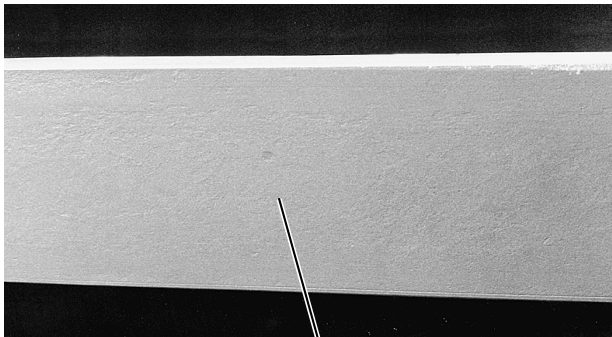

Acceptable
Surface is relatively smooth; within allowable limit.

Figure 4-8

Straightness

See [Figure 4-9](#) for the following procedure.

1. Stretch a line (string or wire) from pin storage hole at one end of strap.
2. Stretch line as tight as possible and tie it off at other end.
3. Mark strap center line. **Do not use center punch!**
4. If string does not align with center line, measure distance from center line to line.

If deviation from straight is greater than maximum allowed in [Table 4-2](#), remove strap from service.

Table 4-2 Strap Straightness

| Strap Length (L) | Maximum Deviation Allowed |
|--------------------------------|---------------------------|
| 1,5 to <3,0 m (5 to <10 ft) | 1,5 mm (0.060 in) |
| 3,0 to <6,1 m (10 to <20 ft) | 3,2 mm (0.125 in) |
| 6,1 to <9,1 m (20 to <30 ft) | 6,4 mm (0.250 in) |
| 9,1 to <12,2 m (30 to <40 ft) | 9,5 mm (0.375 in) |
| 12,2 to <15,2 m (40 to <50 ft) | 12,7 mm (0.50 in) |

< = less than

Straightness (gradual or sweeping bend)

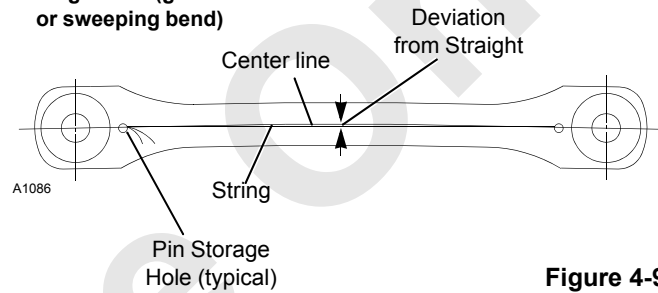

Figure 4-9

Flatness

See [Figure 4-10](#) for the following procedure.

1. Lay strap on a flat surface. **Do not block; strap may sag!**
 2. Stretch a line (string or wire) across top surface of strap from pin storage hole at one end of strap.
 3. Stretch line as tight as possible and tie it off at other end.
 4. Check that line touches top surface of strap at all points along its length.
 5. If string does not touch strap, measure distance from line to strap.
- If deviation from flat is greater than maximum allowed in [Table 4-3](#), remove strap from service.
6. Remove line. Turn strap over.
 7. Repeat steps 1-5 above.

Flatness (includes twisted straps)

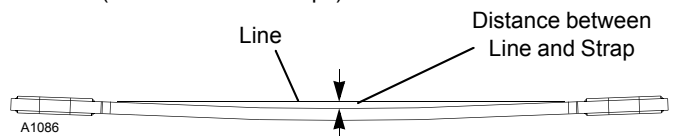

Figure 4-10

Table 4-3 Strap Flatness

| Strap Length (L) m (ft) | Maximum Deviation Allowed | |
|-------------------------------|--|---|
| | 25,4 to <50,8 mm (1 to <2 in) Thick | 50,8 to <101,6 mm (2 to <4 in) Thick |
| <0,9 (<3) | 4,3 mm (0.17 in) | 12,7 mm (0.50 in) |
| 0,9 to <1,2 (3 to <4) | 15,9 mm (0.63 in) | 14,3 mm (0.56 in) |
| 1,2 to <1,5 (4 to <5) | 19,1 mm (0.75 in) | 17,8 mm (0.70 in) |
| 1,5 to <1,8 (5 to <6) | 20,6 mm (0.80 in) | 19,1 mm (0.75 in) |
| 1,8 to <2,1 (6 to <7) | 22,2 mm (0.88 in) | 19,1 mm (0.75 in) |
| 2,1 to <2,4 (7 to <8) | 23,8 mm (0.94 in) | 19,1 mm (0.75 in) |
| 2,4 to <2,7 (8 to <9) | 25,4 mm (1.0 in) | 19,1 mm (0.75 in) |
| 2,7 to <3,0 (9 to <10) | 25,4 mm (1.0 in) | 22,2 mm (0.88 in) |
| 3,0 to <3,7 (10 to <12) | 25,4 mm (1.0 in) | 25,4 mm (1.0 in) |
| ≥3,7 (≥12) | Deviation not to exceed 25,4 mm (1 in) in any 3,7 m (12 ft) length of strap | |

< = less than

≥ = equal to or greater than

Elongated Hole

See [Figure 4-11](#) for the following procedure.

1. Insert pin into hole.
2. Push pin tight against edge of hole along horizontal center line. Measure dimension between pin and hole (View A).
3. Push pin tight against edge of hole along vertical center line. Measure dimension between pin and hole (View B).

If dimension B is not half of A, hole is elongated. Remove strap from service.

If dimension A is greater than 0,8 mm (0.030 in), contact the Manitowoc Crane Care Lattice Team.

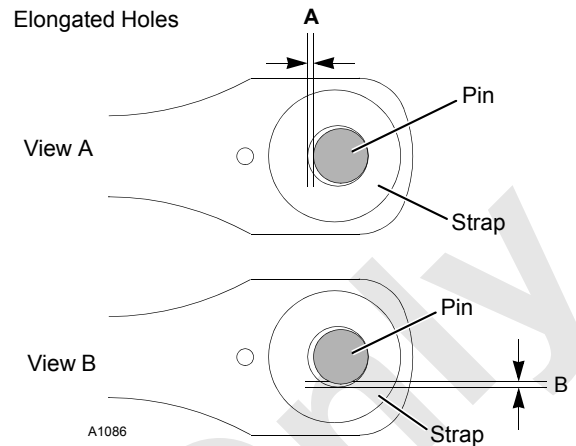
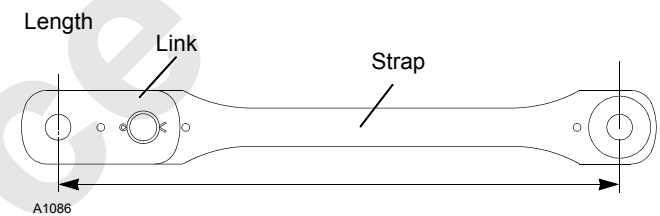

Figure 4-11

Strap Length

Figure 4-12



Measure to check length. See appropriate Rigging Drawing in Operator Manual for original length. Strap length includes connecting link. If change in length is detected, remove strap from service.

Figure 4-12

Storing Straps

Straps should be stored in a protected area. If stored in the open, a protective covering is recommended, especially in a corrosive environment (chemicals, salt water spray, etc.).

Inspect straps in storage for corrosion monthly. If necessary, sandblast to remove corrosion and repaint to maintain a continuous protective surface. If corrosion is not removed, strap will have to be removed from service because reduction in thickness will exceed the maximum allowed.

A full periodic inspection is required for straps returned to service from storage.

Removing Straps from Service

Straps removed from service should be clearly marked to prevent accidental future use. Rendering the strap useless in some way, such as cutting off an end, is recommended.

Inspection Checklist

A Strap Inspection Checklist is provided at the end of this section. The checklist can be reproduced as needed.

Signed and dated copies of the Strap Inspection Checklist must be kept on file at all times for each strap, as the

checklists may be required to verify warranty or product liability claims.

If no damage is found or damage is within specification, check the box () next to the item to indicate that its specific condition was evaluated and found acceptable. If damage is not within specification, indicate so in the box next to the item (for example: **D** to indicate damage).

STRAP INSPECTION CHECKLIST

Inspector's Name _____ Signature _____ Date _____

Length _____ mm (ft) Part Number _____

| | | | | |
|--------------------------------------|---------------------------------|---------------------------------------|-----------------------------------|--|
| <input type="checkbox"/> Dents | <input type="checkbox"/> Kinks | <input type="checkbox"/> Cracks | <input type="checkbox"/> Breaks | <input type="checkbox"/> Corrosion |
| <input type="checkbox"/> Abrasion | <input type="checkbox"/> Length | <input type="checkbox"/> Straightness | <input type="checkbox"/> Flatness | <input type="checkbox"/> Elongated Holes |
| <input type="checkbox"/> Other _____ | | | | |

Length _____ mm (ft) Part Number _____

| | | | | |
|--------------------------------------|---------------------------------|---------------------------------------|-----------------------------------|--|
| <input type="checkbox"/> Dents | <input type="checkbox"/> Kinks | <input type="checkbox"/> Cracks | <input type="checkbox"/> Breaks | <input type="checkbox"/> Corrosion |
| <input type="checkbox"/> Abrasion | <input type="checkbox"/> Length | <input type="checkbox"/> Straightness | <input type="checkbox"/> Flatness | <input type="checkbox"/> Elongated Holes |
| <input type="checkbox"/> Other _____ | | | | |

Length _____ mm (ft) Part Number _____

| | | | | |
|--------------------------------------|---------------------------------|---------------------------------------|-----------------------------------|--|
| <input type="checkbox"/> Dents | <input type="checkbox"/> Kinks | <input type="checkbox"/> Cracks | <input type="checkbox"/> Breaks | <input type="checkbox"/> Corrosion |
| <input type="checkbox"/> Abrasion | <input type="checkbox"/> Length | <input type="checkbox"/> Straightness | <input type="checkbox"/> Flatness | <input type="checkbox"/> Elongated Holes |
| <input type="checkbox"/> Other _____ | | | | |

Length _____ mm (ft) Part Number _____

| | | | | |
|--------------------------------------|---------------------------------|---------------------------------------|-----------------------------------|--|
| <input type="checkbox"/> Dents | <input type="checkbox"/> Kinks | <input type="checkbox"/> Cracks | <input type="checkbox"/> Breaks | <input type="checkbox"/> Corrosion |
| <input type="checkbox"/> Abrasion | <input type="checkbox"/> Length | <input type="checkbox"/> Straightness | <input type="checkbox"/> Flatness | <input type="checkbox"/> Elongated Holes |
| <input type="checkbox"/> Other _____ | | | | |

Length _____ mm (ft) Part Number _____

| | | | | |
|--------------------------------------|---------------------------------|---------------------------------------|-----------------------------------|--|
| <input type="checkbox"/> Dents | <input type="checkbox"/> Kinks | <input type="checkbox"/> Cracks | <input type="checkbox"/> Breaks | <input type="checkbox"/> Corrosion |
| <input type="checkbox"/> Abrasion | <input type="checkbox"/> Length | <input type="checkbox"/> Straightness | <input type="checkbox"/> Flatness | <input type="checkbox"/> Elongated Holes |
| <input type="checkbox"/> Other _____ | | | | |

4

LATTICE SECTION INSPECTION AND LACING REPLACEMENT

Refer to Folio 1316 at the end of this section for lattice section inspection and lacing replacement instructions.

Reference Only

THIS PAGE INTENTIONALLY LEFT BLANK

Reference Only

SECTION 5

HOISTS

TABLE OF CONTENTS

| | |
|---|------|
| Hoist Theory of Operation | 5-1 |
| Overview of the Hoist System | 5-1 |
| Flow Sharing | 5-1 |
| Working and Pilot Flow Components | 5-4 |
| Control Handle | 5-4 |
| Solenoid Valve, Pressure Transducer, and Proportional Valve | 5-4 |
| Directional Control Valves | 5-4 |
| Drum Brake | 5-4 |
| Drum Pawl | 5-5 |
| Drum Motors | 5-5 |
| Drum 3 and Drum 4 Motor | 5-7 |
| Speed Sensor | 5-7 |
| Free Fall System (Optional) | 5-8 |
| Speed Sensor—Free Fall Drum | 5-11 |
| Electrical Diagrams | 5-11 |
| Drum Gearboxes | 5-19 |
| Gear Oil Specifications | 5-19 |
| Oil Analysis | 5-19 |
| Periodic Maintenance | 5-19 |
| Initial Operation | 5-19 |
| Monthly or 200 Hours | 5-19 |
| Every 6 Months or 1,000 Hours | 5-19 |
| Quick-Drain Valve | 5-19 |
| Oil Change Procedure | 5-19 |
| Drums 1 and 2 Gearbox with Free Fall Option | 5-20 |
| Drums 1 and 2 Gearbox without Free Fall Option | 5-21 |
| Drum 3 Gearbox | 5-22 |
| Drum 4 Gearbox | 5-26 |
| Drum 1 Pawl | 5-29 |
| Operation | 5-29 |
| Maintenance | 5-29 |
| Daily | 5-29 |
| Weekly | 5-29 |
| Drum 4 Pawl | 5-31 |
| Operation | 5-31 |
| Maintenance | 5-31 |
| Daily | 5-31 |
| Weekly | 5-31 |
| Drum 3 Pawl | 5-32 |
| Operation | 5-32 |
| Maintenance | 5-32 |
| Daily | 5-32 |
| Monthly | 5-32 |
| Adjustment | 5-32 |
| Speed Sensor—Hoist Motors | 5-33 |
| Replacement | 5-33 |
| Speed Sensor—Free Fall Drums | 5-35 |
| Maintenance | 5-35 |
| Minimum Bail Limit (Drum 3) | 5-37 |
| Limit Switch Replacement | 5-37 |
| Removal | 5-37 |

| | |
|--|------|
| Installation | 5-37 |
| Adjustment | 5-37 |
| Weekly Maintenance | 5-37 |
| Pressure Roller (Drum 3) | 5-39 |
| Daily Maintenance | 5-39 |
| Spring Replacement | 5-39 |
| Minimum Bail Limits and Pressure Rollers (Drums 1 and 2) | 5-40 |
| Minimum Bail Limit (Drum 1 and 2) | 5-43 |
| Limit Switch Replacement | 5-43 |
| Removal | 5-43 |
| Installation | 5-43 |
| Adjustment | 5-43 |
| Weekly Maintenance | 5-43 |
| Pressure Roller (Drum 1 and 2) | 5-45 |
| Pressure Roller (Drum 2) | 5-45 |
| Pressure Roller (Drum 1) | 5-45 |
| Daily Maintenance | 5-45 |
| Spring Replacement | 5-45 |
| Block-Up Limit Switch | 5-46 |
| Theory of Operation | 5-47 |
| Weekly Maintenance | 5-47 |
| Adjustment | 5-49 |
| Free Fall Brake | 5-51 |
| Removing Free Fall Brake Cover | 5-51 |
| Installing Free Fall Brake Cover | 5-51 |
| Wire Rope Inspection and Replacement | 5-52 |
| Wire Rope Lubrication | 5-52 |
| Maintain a Wire Rope Condition Report | 5-52 |
| Required Inspection Intervals | 5-52 |
| Wire Rope Care and Replacement Guidelines | 5-52 |
| Daily Inspection | 5-53 |
| Periodic Comprehensive Inspection | 5-54 |
| Determining Frequency of Inspection | 5-54 |
| Replacement Criteria | 5-54 |
| Reduction in Rope Diameter | 5-54 |
| Broken Rope Wires | 5-55 |
| Rope That Has Been Idle a Month or More | 5-56 |
| Distributing Wire Rope Wear | 5-56 |
| Sheave, Roller, and Drum Inspection (Weekly) | 5-57 |
| Load Block and Hook-and-Weight Ball Inspection | 5-60 |

SECTION 5

HOISTS

HOIST THEORY OF OPERATION

This section will discuss the electrical and hydraulic control of the crane hoists. For details on individual components, some are covered later in this section and others are covered in Section 2 Hydraulics and Section 3 Electrical.

NOTE For a description of the overall crane hydraulic system and additional free fall details on the components described in this section, refer to Section 2.

Overview of the Hoist System

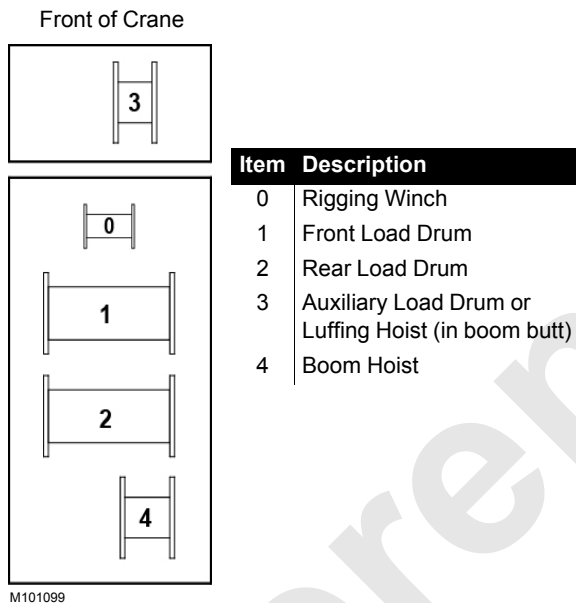

Figure 5-1. Drum Number Designations

Also see [Figure 5-2 on page 5-2](#).

Each hoist system (drum 1, 2, 3, and 4) is comprised of essentially identical control circuits and components. The main differences between the hoists are:

- Drum 1 and 2 use identical motors. See [Drum 1 and Drum 2 Motor on page 5-5](#).
- Drum 3 and 4 use identical motors. See [Drum 3 and Drum 4 Motor on page 5-7](#).

- The control software governs the operational characteristics differently for each hoist.
- A free fall option is available for hoists 1 and 2. See [Free Fall System \(Optional\) on page 5-8](#).

The hydraulic system for each hoist motor is comprised of a high-volume, high-pressure circuit and a low-pressure pilot circuit. The high-pressure, high-volume flow is supplied by the double main pump. The pilot system is supplied by the charge pump.

The main pump generates two flows to the control valve manifold. The two flows can remain separate within the manifold or they can be shared by use of the Drum Speed switch. See [Flow Sharing on page 5-1](#).

For each hoist, the pilot system consists of two hydraulic circuits which originate at the control handle in the operator cab: an **up** circuit and a **down** circuit. Both pilot circuits terminate at a directional control valve that is proportional and is located on the control valve manifold.

Depending on how the directional control valve is commanded by the control handle (by way of the pilot system), the valve routes high pressure working flow to the A port or the B port of the hoist motor.

Flow Sharing

NOTE The hoist motors are on an open-loop system fed by the double main pump. This means that the hoist motor speed can be affected by the simultaneous operation of other crane equipment. See Section 2 for more information on the open loop system.

At times it may be desirable to combine the two flows from the main pump. This can be done through the use of the Drum Speed switch. When the switch is moved to the high speed position, it energizes a solenoid valve located in the control valve manifold. The solenoid valve shifts an on-off valve which connects the load sense and working pressure flows within the two halves of the control valve manifold.

With the Drum Speed switch in the closed position (high speed), both of the main pump flows feed all hoist and travel motors. In the open position (low speed), each flow separately supplies two hoist motors and one travel motor.

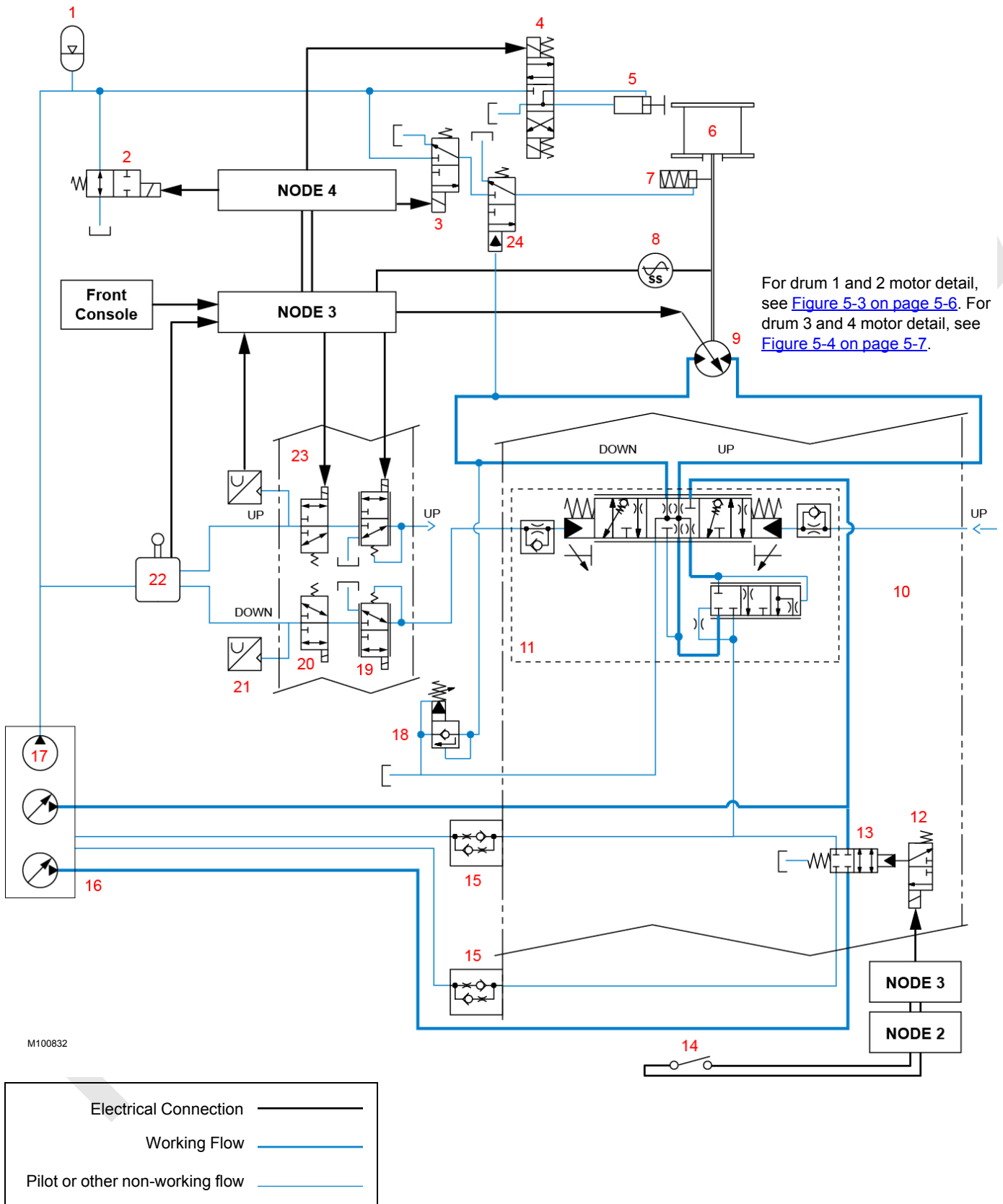

Figure 5-2. Hoist System Diagram

Legend for [Figure 5-2 on page 5-2](#).

| Item | Description | Item | Description |
|------|--------------------------------|------|--------------------------------|
| 1 | Accumulator | 13 | Combined Flow Valve |
| 2 | Pilot Pressure Unloading Valve | 14 | Speed Switch |
| 3 | Drum Brake Valve | 15 | Load Sense Check Valve/Orifice |
| 4 | Drum Pawl Valve (Drum 1 only) | 16 | Double Main Pump |
| 5 | Drum Pawl (Drum 1 only) | 17 | Pilot Pressure Pump |
| 6 | Drum 1, 2 | 18 | Relief Valve, Down Pressure |
| 7 | Drum Brake | 19 | Proportional Valve |
| 8 | Motor Speed Sensor | 20 | Solenoid Valve |
| 9 | Hoist Motor | 21 | Pressure Transducer |
| 10 | Manifold, Control Valves | 22 | Control Handle |
| 11 | Directional Control Valve | 23 | Manifold, Pilot Signal Valve |
| 12 | Combined Flow Solenoid Valve | 24 | Drum Brake Defeat Valve |

Working and Pilot Flow Components

See [Figure 5-2 on page 5-2](#).

Control Handle

When the operator moves a control handle off-center, the hydraulic valve on the control handle allows flow into either the **up** or the **down** pilot circuit. The pressure in the pilot circuit will be proportional to how far the operator moves the handle.

In the control handle is an electric coil-operated rotation indicator (“thumper”) which pulsates with a frequency proportional to drum speed. This communicates to the operator that the drum is turning and how fast. The coil responds to a voltage signal which originates at the drum speed sensor.

NOTE A control handle can operate different hoists depending on the mode the operator has entered into the main display. This is covered in more detail in the MLC165-1 Main Display Operation manual.

Solenoid Valve, Pressure Transducer, and Proportional Valve

In the **up** and **down** pilot circuits, between the control handle valve and the directional control valve, is the pilot signal valve manifold. This manifold contains the solenoid valve, pressure transducer, and proportional flow valve. These three components are in each **up** and **down** circuit.

The **solenoid valves** are turned on or off according to how the operator configures the crane in the GUI screens. These valves allow different control handles to operate different drums by directing pilot flow to different hoist circuits.

The solenoid valves are also used by the crane software to stop hydraulic flow when operating limits are met, such as the maximum boom angle limit.

The **pressure transducers** provide the control system with a variable 1–5Vdc corresponding to the pressure in the pilot circuit (as determined by control handle position).

The 1–5Vdc is used for two purposes:

- It signals the control system that a control handle has moved off center
- It is processed by the control system to determine the appropriate displacement control signal to Drum 1 and drum 2 motors.

The **proportional flow valves** are used to limit the motor speed by a percentage. This percentage is set by the operator in the crane control screens (see the MLC165-1 Main Display Operation manual for instructions).

Directional Control Valves

The directional control valves are situated on a manifold which is divided in half, with three directional control valves (travel and hoist motors) on each half. Each manifold half is supplied by one flow from the main pump and has separate working and load sense circuits.

The load sense system connects each directional control valve to the main pump displacement control. The load sense system is designed so that the pump responds to the directional control valve that has the highest working pressure (greatest load demand). When the manifold is in the divided condition, one pump half responds to the demand of three directional control valves.

However, when the Drum Speed switch is in the closed (High Speed) position, the manifold halves are connected so that both pump flows are joined to supply all six directional control valves equally. Also joined are the sense circuits so that each pump responds equally to load demand.

The **up** and **down** handle control circuits terminate at the directional control valve. This means that pressure from the control handle valve acts upon on one side or the other of the directional control valve, resulting in working flow being directed to one side of the motor or the other. The amount of pilot pressure from the control handle determines how far the directional valve spool will open.

Drum Brake

A disc-type brake is installed between the hoist motor and the hoist gearbox. The brake is spring-applied and hydraulically released in response to control handle movement.

When the control handle is moved off center, the controller responds to a pilot pressure signal and correspondingly sends a 24Vdc signal to the brake valve solenoid. The brake valve shifts to allow pilot pressure to flow through the brake defeat valve to the brake, and the brake releases.

Note that, the brake defeat valve is piloted open anytime the engine is running.

When the control handle is moved back to center and the controller sees zero pilot pressure for a set amount of time, the brake valve shifts to vent the pressure from the brake to tank, and the brake spring applies.

If pressure is lost to the hoist motor for any reason, the brake defeat valve closes to vent the pressure from the brake to tank. This allows the brake to immediately apply to stop the hoist drum from lowering.

Drum Pawl

The drum pawls are controlled by node 4 voltage, the drum pawl directional control valves, and the park switches in the cab. For pawl operation see:

[Drum 1 Pawl on page 5-29](#)

[Drum 4 Pawl on page 5-31](#)

[Operation on page 5-32](#)

Drum Motors

See [Figure 5-3 on page 5-6](#).

Drum 1 and Drum 2 Motor

Drums 1 and 2 are driven by variable-displacement motors. (See Motor Displacement Control below).

Provision for motor cooling is not required. Normal working flow is sufficient for cooling.

Motor Displacement Control (MDC) Solenoid Valve

Motor displacement is varied by the MDC solenoid valve acting on an internal hydraulic actuator. The actuator is controlled by the solenoid until the system pressure reaches the setting of the pressure compensated override (see PCOR below).

When the control handle is in the center position, the motor is at maximum displacement (high torque, low speed). When the control handle is moved off center, the control system outputs a proportional voltage signal (4.5–10Vdc) to the MDC valve's solenoid, which shifts the valve's spool in accordance with crane programming. The valve spool shifts to allow flow to or from the actuator, which moves the swashplate. The valve spool is also mechanically connected to the actuator by a spring.

Control input for the control signal is the 1–5Vdc from the pressure transducer. An electronic pressure compensator is used to maintain a maximum displacement of 260 bar (3800 psi).

The solenoid coil normally draws 200mA–600mA at 68°F (20°C), with coil resistance nominally 22.7 ohms.

Time Delay orifice—An orifice in the flow to the MDC actuator dampens the response time of the actuator, and by extension, dampens motor response to changes in control handle position and load. This helps dampen any abruptness in motor operation during changes in control handle position.

The orifice will restrict flow in and out of the servo chamber, resulting in lag in both directions.

Pressure Compensation Override (PCOR)

The PCOR ensures that the motor delivers sufficient torque when required. When working pressure (a reflection of load) reaches 4,000 psi (275 bar), the PCOR begins shifting the control actuator toward maximum displacement. It does this by using the working pressure to shift the spool, which redirects to tank the pilot circuit that supplies the barrel end of the actuator. This causes the actuator to retract, moving the swashplate for a larger displacement.

The valve is fully open at the maximum system pressure.

Counterbalance with Pilot-Operated Relief

Attached to the motor is a counterbalance proportional valve to which the working pressure hoses are connected. The purpose of the valve is to:

- Ensure that the hoist powers down
- Hold the load when the control handle is in center
- Ensure smooth start, stop, and changes in hoist speed
- Relieve momentary excess pressure that may occur when bringing a heavy load to a quick stop.

The valve functions differently in each direction:

Lowering and holding a load—When flow is in the lowering direction, the counterbalance valve functions as a hydraulically operated proportional spool valve which checks motor outflow in one position and in the other position allows motor outflow.

When there is no working pressure (handle in center), a check valve halts hydraulic flow in the return side of the **down** circuit. This prevents the hoist motor from turning in the **down** direction. As the control handle is moved off-center in the **up** direction, the working pressure begins to act on the valve, which begins to shift to the unchecked position to allow motor outflow.

When the control handle is moved toward center, the counterbalance valve begins to close, slowing the load. At center, the check valve is again closed, preventing motor outflow and downward movement of the load.

An orifice in the unchecked circuit prevents abruptness in starting and changes in hoist speed.

Pilot-operated relief valve—This relief valve protects the motor from excessive pressure, such as might occur when bringing a heavy load to a quick stop when lowering. The valve is factory set to 5,800 psi (400 bar).

Raising a load—When system flow is in the **up** direction, the counterbalance valve remains in the unchecked position and has no effect on operation.

Test Meter Port

Port M1 is in the PCOR output pilot circuit to the displacement control hydraulic cylinder.

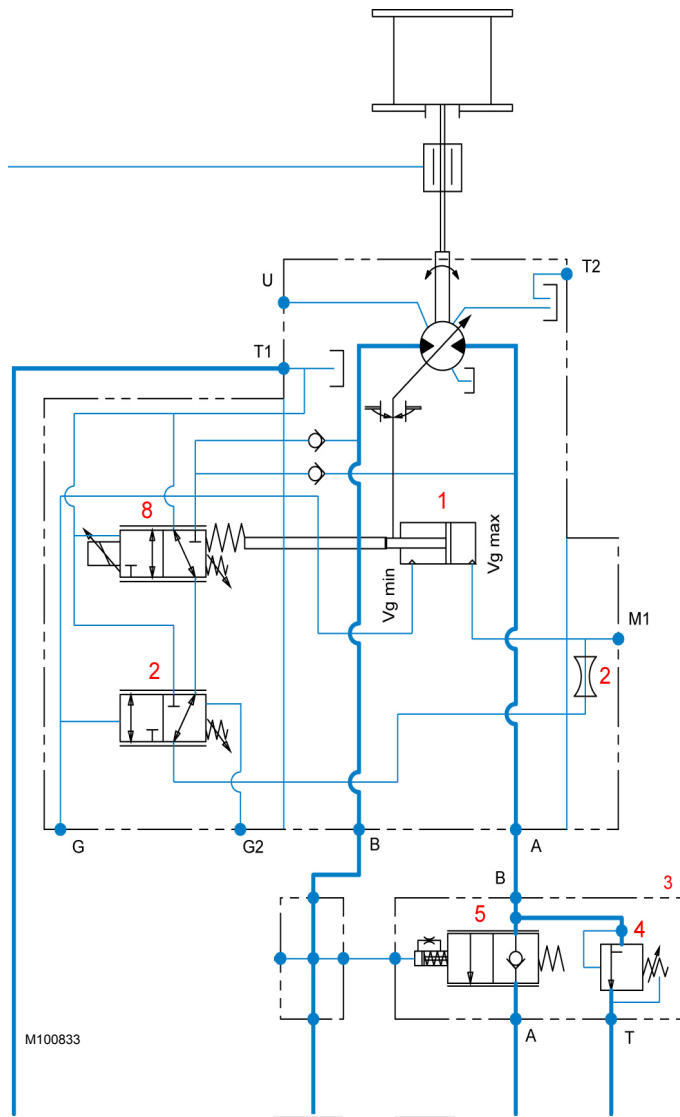

Working Flow —————
 Pilot or other non-working flow - - - - -

| Item | Description |
|------|---|
| 1 | Motor Displacement Control Actuator |
| 2 | Time Delay Orifice |
| 3 | Counterbalance Valve Assembly |
| 4 | Relief Valve |
| 5 | Counterbalance Valve |
| 6 | Not Used |
| 7 | Pressure Compensation Relief Valve (PCOR) |
| 8 | Motor Displacement Control Valve |

For continuation of hydraulic circuits, see [Figure 5-2 on page 5-2](#).

Figure 5-3. Hoist Drum 1 and 2 Motor Hydraulic Diagram

Drum 3 and Drum 4 Motor

See [Figure 5-4](#).

The fixed axial piston motors for hoists 3 and 4 are identical. Speed is governed by the position of the hoist control handle. Internal leakage exits via a tank port. Cooling is accomplished by working flow.

Pressure Relief

For motor protection, each motor has two pilot-operated pressure-relief valves, one for hoisting and one for lowering. Relief pressure is factory-set to (5,217 psi) 360 bar.

Test Meter Ports

Ports MA and MB are for connecting a pressure test meter to the respective work flow circuit.

Speed Sensor

When a drum motor rotates, a hall-effect sensor mounted on the motor sends an input voltage to the designated node controller. The controller in turn sends corresponding voltage pulses to the rotation indicator in the control handle.

NOTE If the drum is equipped with a free fall brake, the motor-mounted speed sensor is not used. In its place is an external encoder-type sensor. See [Free Fall System \(Optional\) on page 5-8](#).

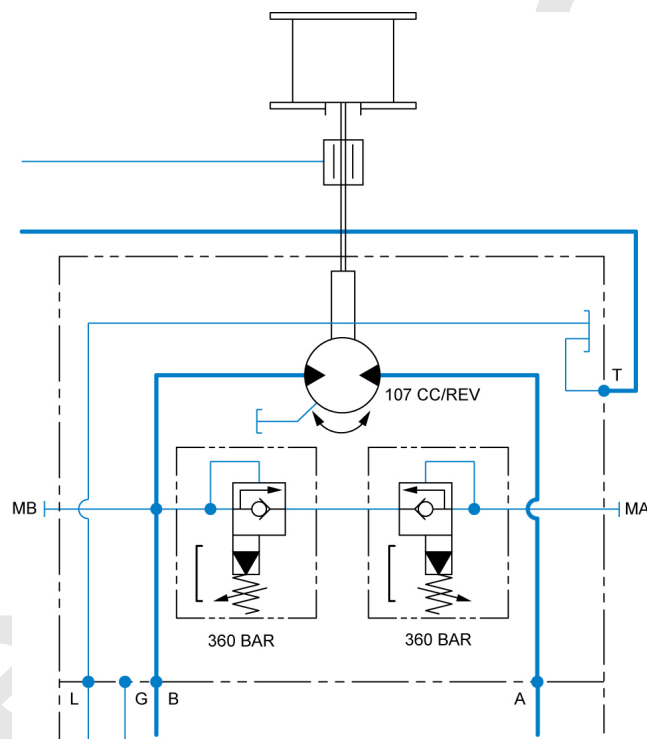

Figure 5-4. Hoist Drum 3 and 4 Motor Diagram

Free Fall System (Optional)

Drum 1, Drum 2, or both drums can be equipped with the free fall (FF) option. When FF is enabled, a large brake using spring-applied, hydraulically released friction discs is used to control the lowering of a load. Raising a load when FF is enabled works the same as in normal operation.

NOTE When the crane is not in FF mode, depressing the clutch/brake pedal has no effect on hoist operation.

The motor and motor brake used on the FF drum are the same as are used on the non-free fall drum. The only difference is that the motor supplied with the FF option does

not have a speed sensor. Drum speed is taken from an external speed sensor assembly (See [Speed Sensor—Free Fall Drum on page 5-11](#)).

Cooling oil flow through the brake is continuous whether or not FF mode is enabled. Cooling oil flow (50 psi, 3.5 bar) is provided by the FF cooling pump, which is dedicated for this purpose.

During free fall operation, the accessory pump pressure is limited to 1,000 psi (69 bar) by a pressure control valve on the pump. Brake release pressure is reduced to 800 psi (55 bar) by a pressure compensator in the free fall pedals.

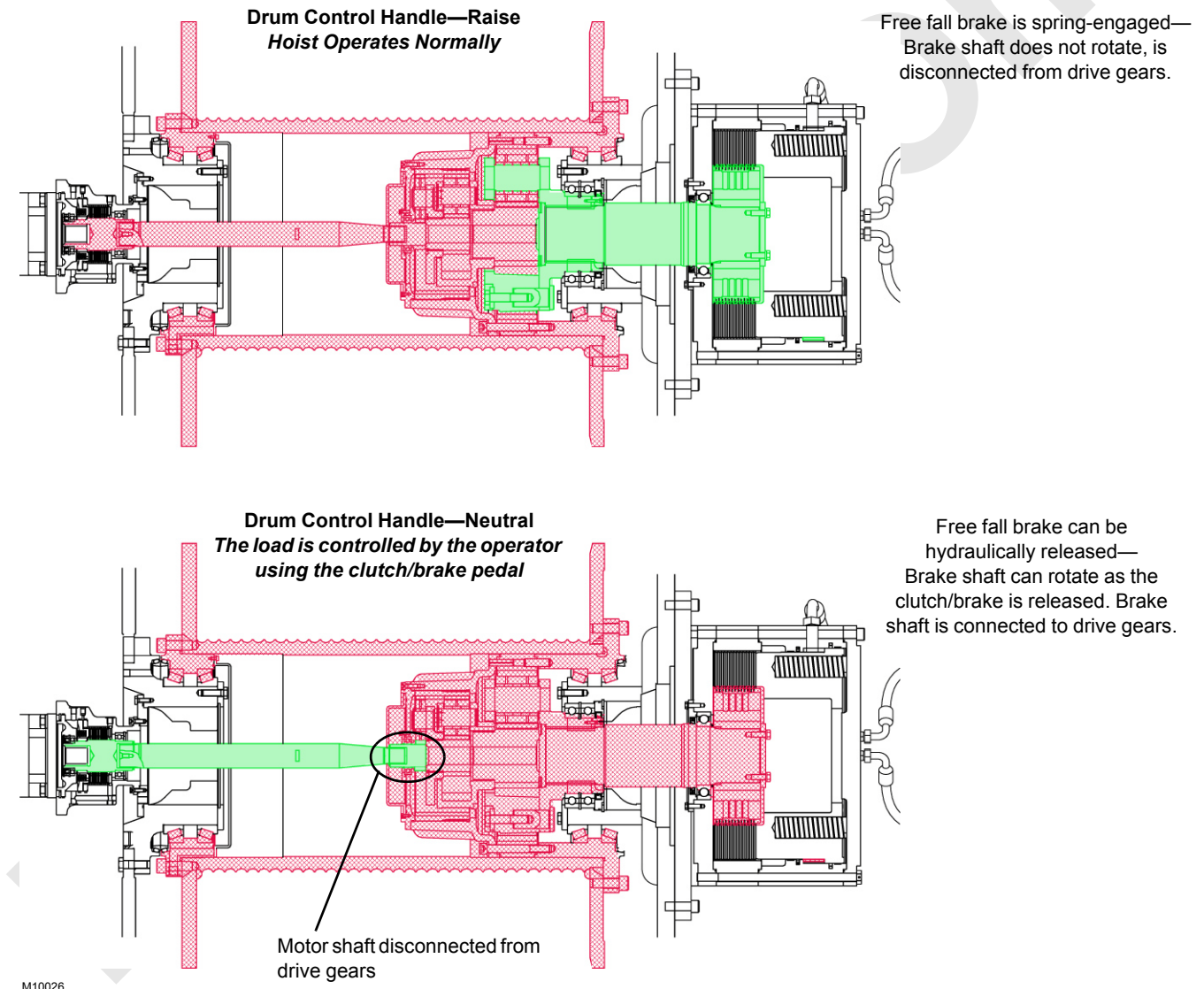
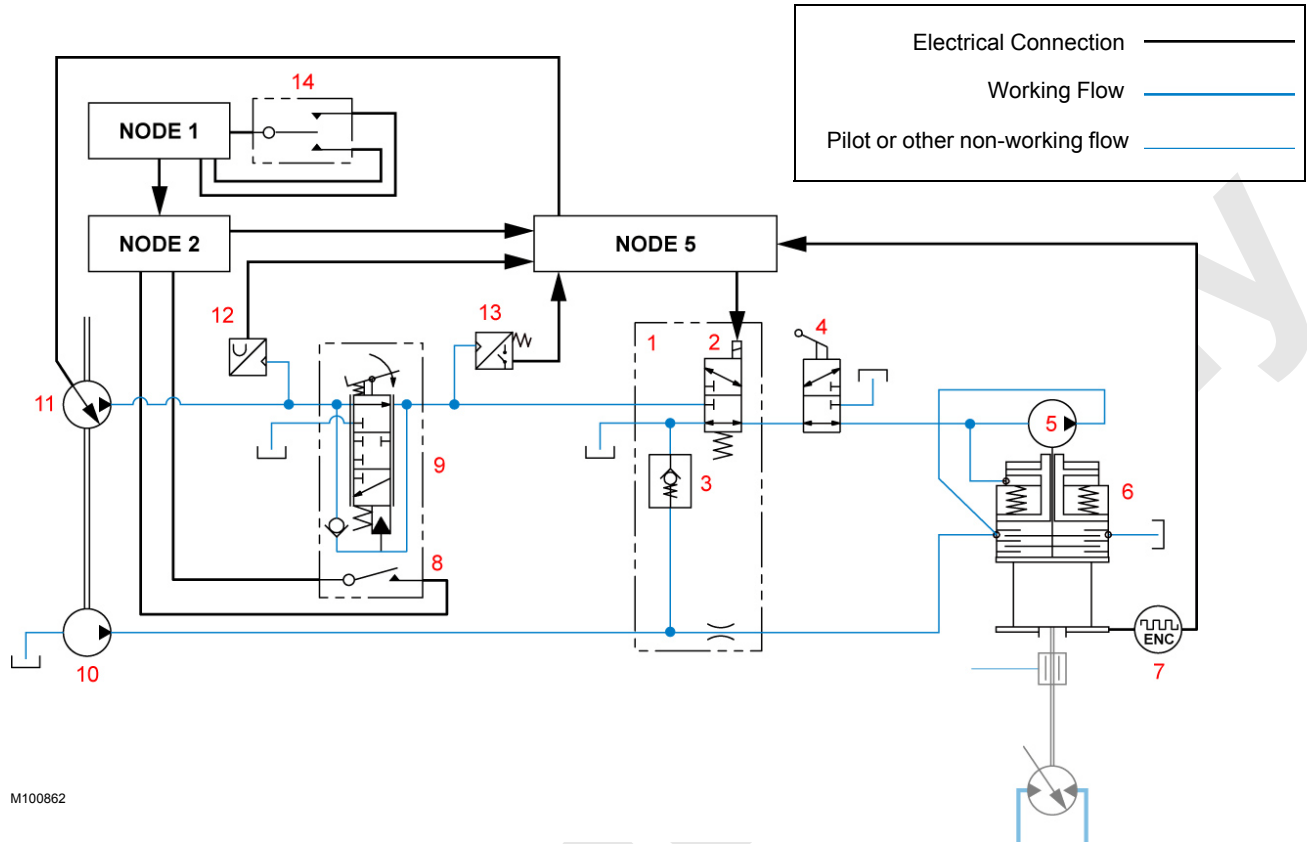

Figure 5-5. Drum Operation—Free Fall Mode



M100862

| Item | Description |
|------|---|
| 1 | Free Fall Manifold |
| 2 | Free Fall Enable Solenoid |
| 3 | Check Valve |
| 4 | Manual On-Off Valve |
| 5 | Internal Pump, Free Fall Brake |
| 6 | Free Fall Brake Assembly |
| 7 | Drum Speed Encoder |
| 8 | Pedal Safety Latch Switch |
| 9 | Brake Pedal |
| 10 | Brake Cooling Pump |
| 11 | Accessory Pump |
| 12 | Pressure Transducer |
| 13 | Pressure Switch |
| 14 | Free Fall Drum Select/Enable Key Switch |

For the remainder of the hoist hydraulic system diagram, see [Hoist System Diagram on page 5-2](#)

Figure 5-6. System Diagram—Free Fall Components

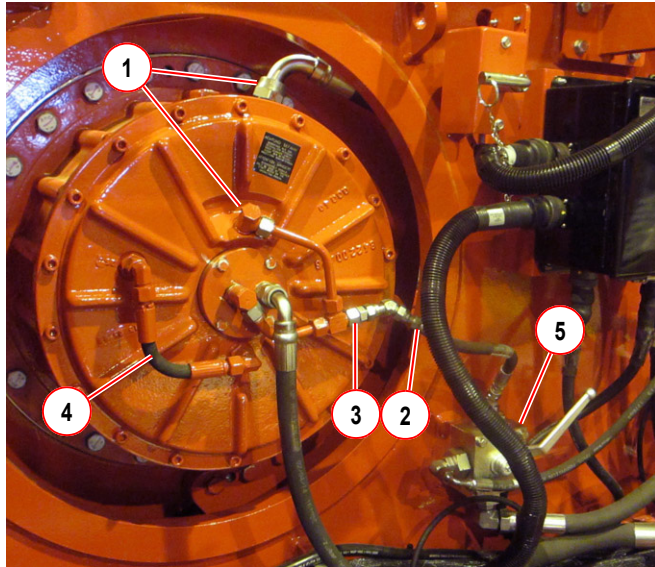

M101862

| Item | Description |
|------|--|
| 1 | Cooling Oil Hoses |
| 2 | Release Pressure Hose |
| 3 | Fitting for Manual Hydraulic Pump |
| 4 | Hose for Internal Drum-Powered Pump |
| 5 | Manual Hydraulic Off-On Valve (Open position shown) |

Figure 5-7. Free Fall Brake

! WARNING
Falling Load Hazard

When the free fall mode is fully enabled, the load will fall uncontrolled unless the clutch/brake pedal is applied.

Always be ready to apply the clutch/brake pedal so lowering speed can be controlled.

If this is not done, the load can fall, possibly resulting in injury or death.

To prevent the load from falling when free fall is selected for a drum, latch down the free fall clutch/brake pedal.

To release the free fall brake, three conditions must be met:

- The hydraulic valve (5, [Figure 5-6 on page 5-9](#)) is in the open (**on**) position.
- The clutch/brake pedal is all the way down until it latches.

NOTE When the pedal is latched down, flow from the accessory pump to the pedal valve is routed to the tank (no pressure to the brake).

- The free fall enable/disable key switch is toggled to the drum 1 and/or drum 2 position. Through software, this switch enables the FF solenoid to respond to the control handle.

For specific operating instructions, see Section 3 of the MLC165-1 Operator Manual.

In the open position, the manual hydraulic valve allows flow from the brake pedal. When the operator allows the pedal to rise, a proportional valve connected to the pedal will begin to open, and the pressure will build in the hydraulic circuit to the brake.

When the pedals are latched down, pressure in the circuit will drop below 100 psi (6,9 bar). If all other conditions are met and the free fall enable key is turned on, the control system activates the free fall solenoid valve, allowing pressure to reach the free fall brake. As the pedal is allowed to rise, the brake will release and the load will begin to descend. Full brake release occurs at 1,000 psi (69 bar).

Adjusting the slip setting on screen will limit the maximum pressure available to the brake from the accessory pump.

When free fall is enabled, the drum control handle will operate the same as in normal (non-free fall) operation, but the operator must remember to use the clutch/brake pedal to control lowering while the control handle is in center. See the MLC165-1 Operator Manual for free fall operating procedures.

CAUTION

Avoid Gearbox/Brake Motor Damage

While a load is being lowered using the free fall /clutch brake, leave the control handle at the center position. Before using the control handle, use the free fall clutch/brake to bring the drum to a complete stop.

Moving the control handle off center while a load is free falling will immediately engage the motor shaft to the planetary gears, which can result in extensive equipment damage.

Speed Sensor—Free Fall Drum

When the drum rotates, an encoder on the speed sensor assembly ([Figure 5-25 on page 5-35](#)) sends a 24 volt direction and speed signal to the control system. The control system sends a 24 volt output to a rotation indicator (thumper solenoid) in the control handle. The rotation indicator pulsates with a varying frequency to indicate drum rotational speed.

ELECTRICAL DIAGRAMS

Electrical diagrams on the following pages are adapted from the Electrical Schematic drawing 81019880.

See [Figure 5-8](#) for a key to the line colors used in the electrical diagrams.

M100848







| | |
|----------------------|---|
| 12 Volts or 24 Volts |  |
| 5 Volts |  |
| Digital Input |  |
| Digital Output |  |
| Analog Input |  |
| Ground |  |
| Encoder |  |

Figure 5-8. Key to Colors on the Electrical Diagram:



M100837

Figure 5-9. Electrical Controls—Drum 1 (Front Main Hoist)

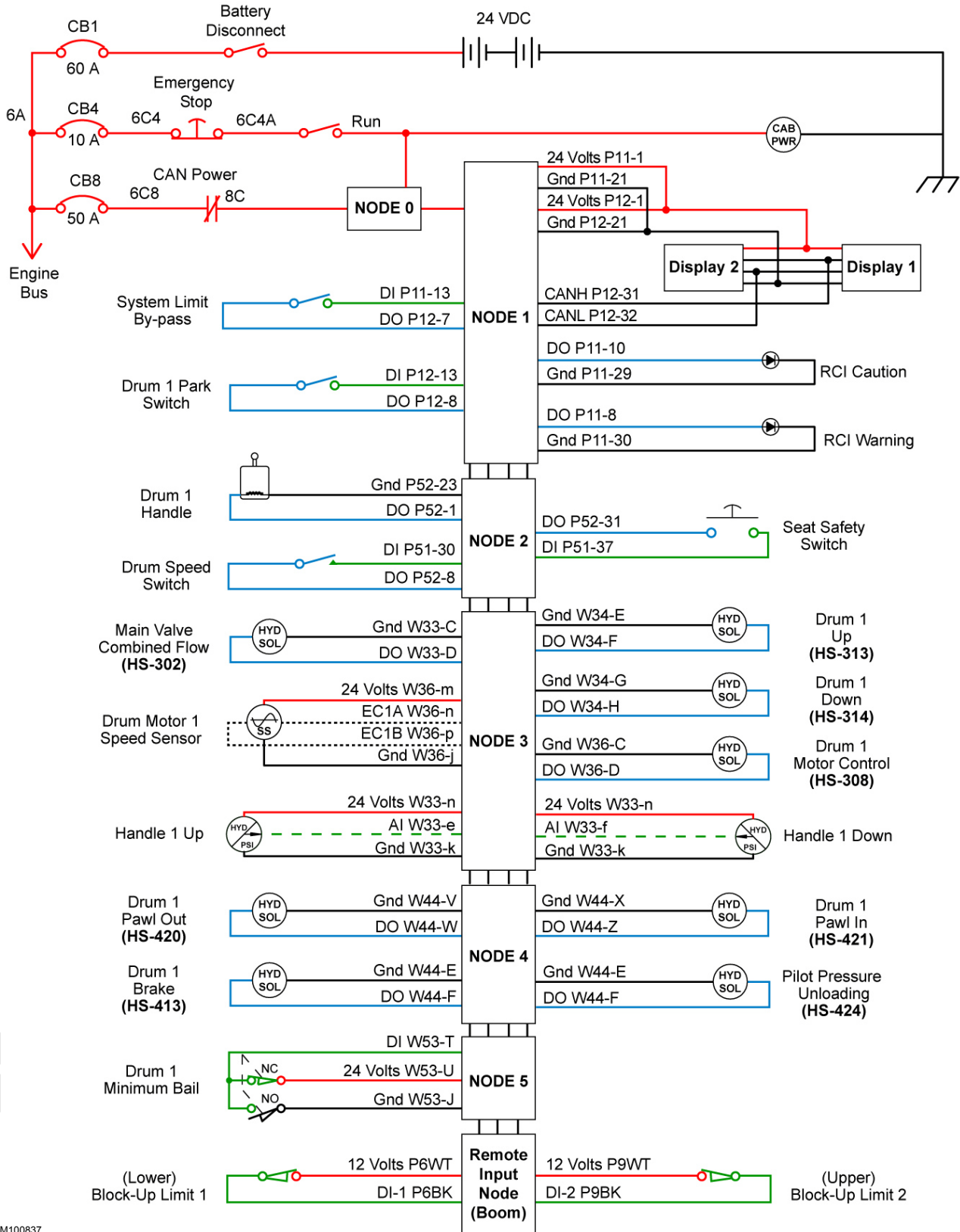
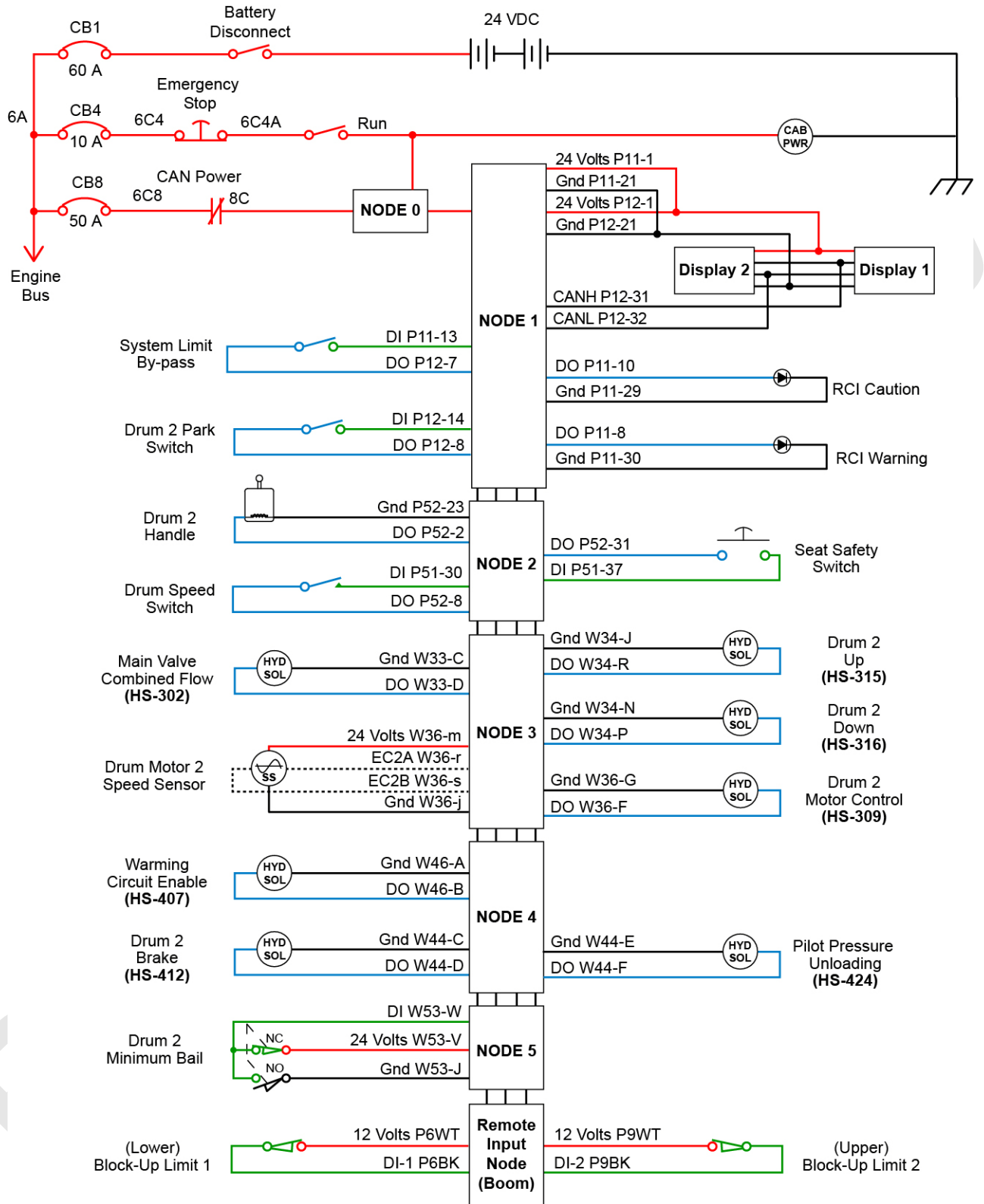

M100865

Figure 5-10. Electrical Controls—Drum 2 (Rear Main Hoist)

5

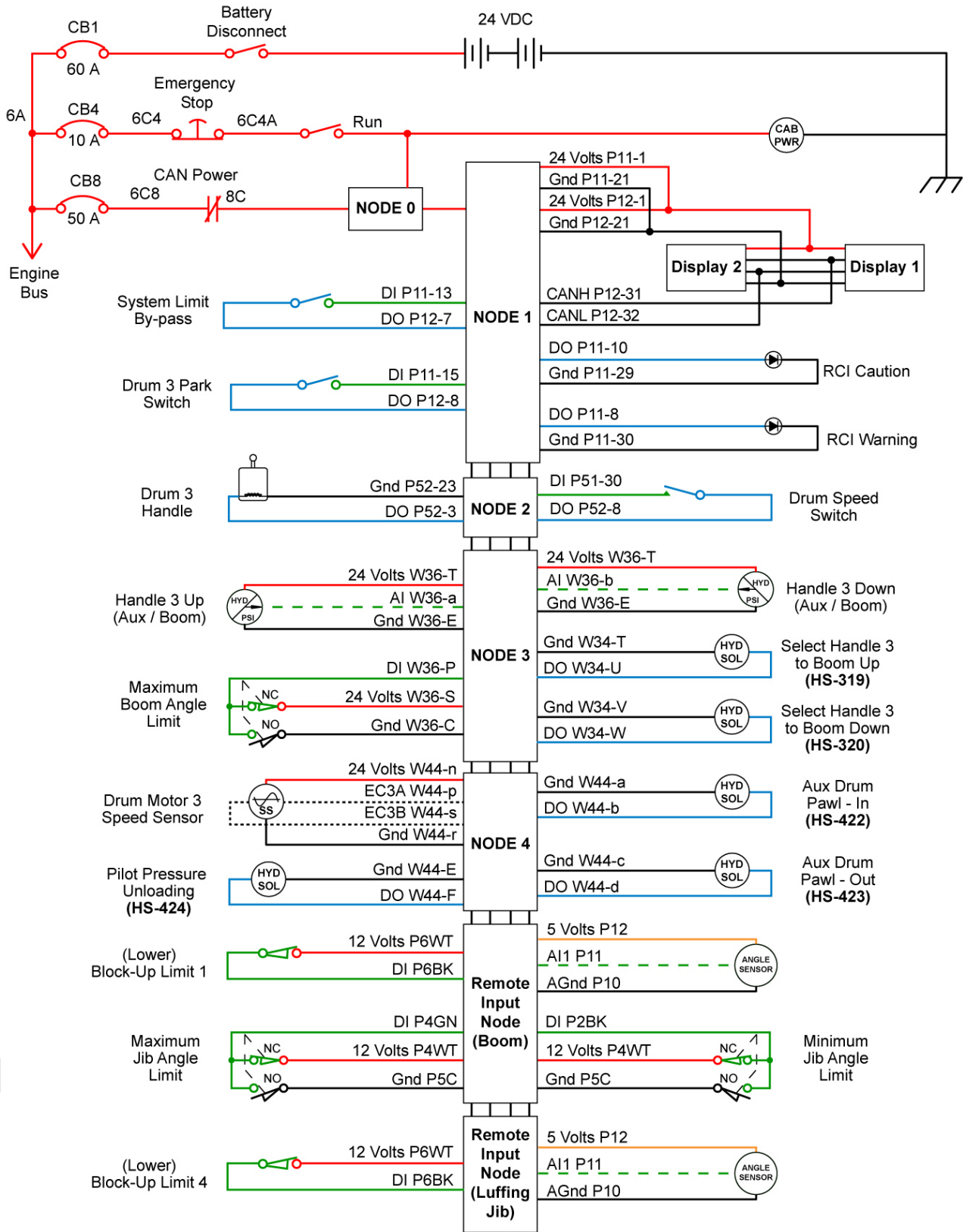

M100867

Figure 5-11. Electrical Controls—Drum 3 (Auxiliary or Luffing Hoist)

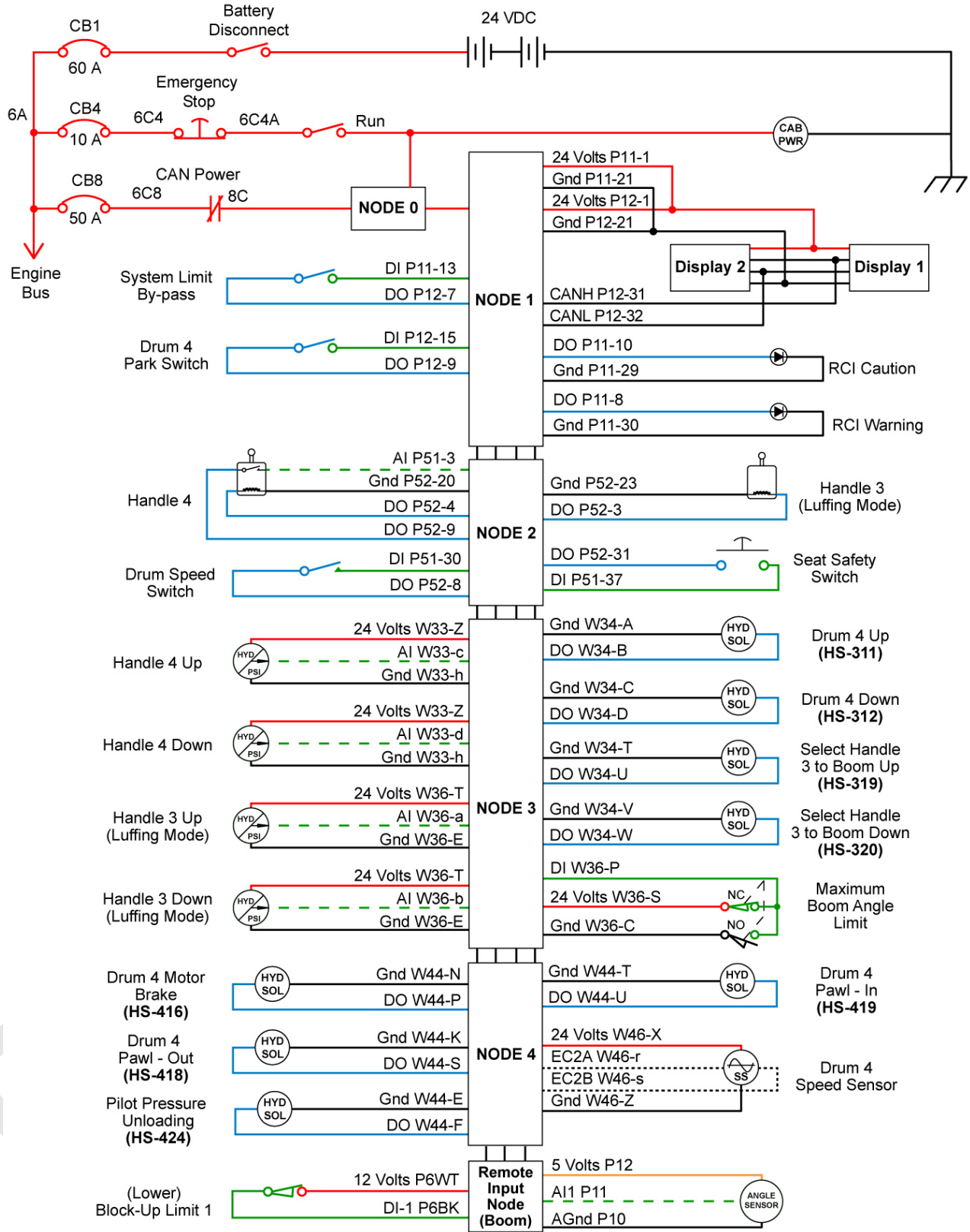

M100864

Figure 5-12. Electrical Controls—Drum 4 (Boom Hoist)

5

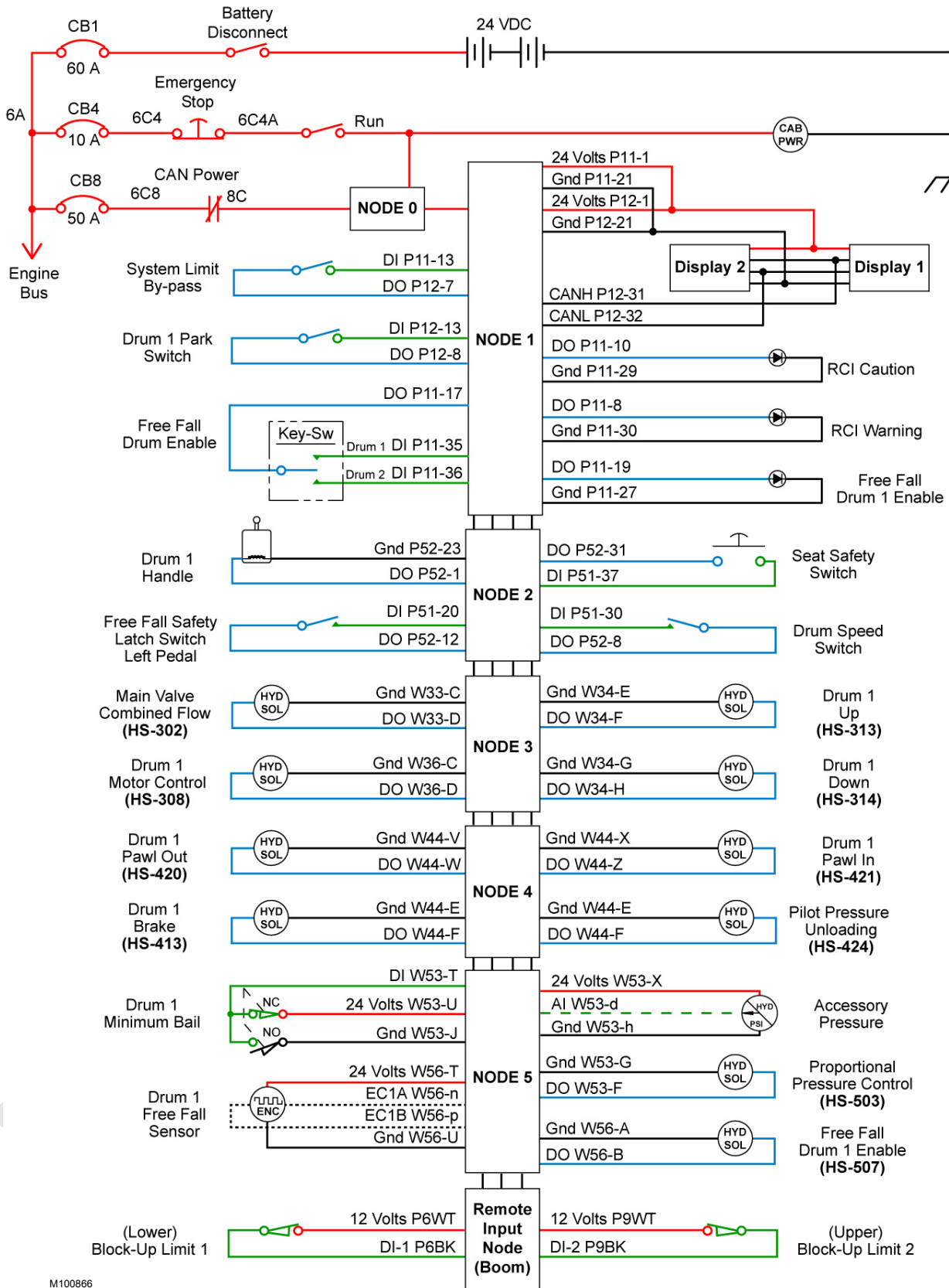

M100866

Figure 5-13. Electrical Controls—Drum 1 with Free Fall

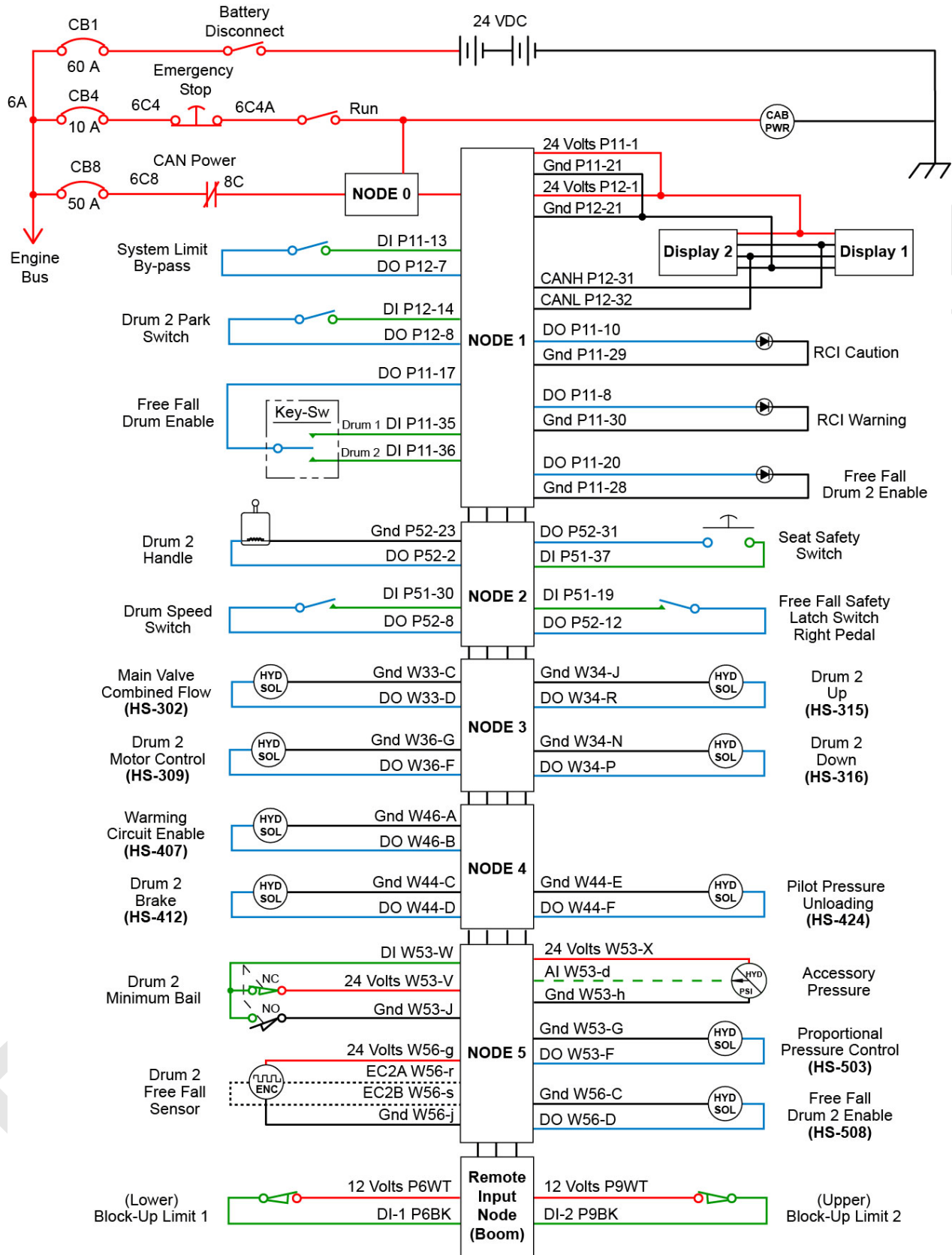

M100868

Figure 5-14. Electrical Controls—Drum 2 with Free Fall

THIS PAGE INTENTIONALLY LEFT BLANK

Reference Only

DRUM GEARBOXES

Each drum gearbox is filled with gear oil and is not open to the inside of the drum. Only the gearbox itself contains oil. Maintenance consists of periodically checking the level and changing the oil.

Gear Oil Specifications

For gear oil specifications, see the Lubrication Guide supplied with the crane.

Oil Analysis

An oil analysis program is the best way to determine the optimal oil change interval and the condition of the drum gearboxes.

Periodic Maintenance

Initial Operation

Drums 1 and 2 without free fall, Drum 3, and Drum 4: drain and refill the gearboxes after the first 150 hours of operation.

Drums 1 and 2 with free fall: drain and refill the gearboxes after the first 200 hours of operation.

Monthly or 200 Hours

Check the oil level in the drum gearboxes every 200 hours of operation or monthly, whichever occurs first. For details, see the Lubrication Guide supplied with the crane.

Every 6 Months or 1,000 Hours

Drain and refill the drum gearboxes every 1,000 hours of operation or every 6 months, whichever occurs first.

Quick-Drain Valve

Each drum gearbox is equipped with a quick-drain valve which requires use of the quick-drain drainer assembly shown in [Figure 5-15](#). The quick-drain drainer assembly is stored in the parts box supplied with the crane.

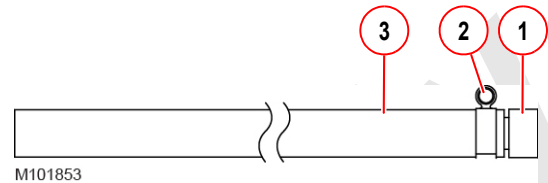

| Item | Description |
|------|--|
| 1 | Quick-Drain Drainer |
| 2 | Hose Clamp |
| 3 | Hose: 3/4 in (19 mm) Inside Diameter by 10 ft (3,0 m) Long |

Figure 5-15. Quick-Drain Drainer Assembly

Oil Change Procedure

The oil change interval may be adjusted according to the results of an oil analysis program.

Change the oil when the gearboxes are warm, not hot.

| Gearbox | Oil Change Procedure |
|--|---------------------------|
| Drums 1 and 2 with Free Fall Option | page 5-20 |
| Drums 1 and 2 without Free Fall Option | page 5-21 |
| Drum 3 | page 5-22 |
| Drum 4 | page 5-26 |

Drums 1 and 2 Gearbox with Free Fall Option

See [Figure 5-16](#) for the following instructions.

NOTE To prevent harmful contaminants from entering the gearbox, thoroughly clean components before disconnecting or connecting them.

1. Lock out/tag out the crane.
2. Remove the dust cap (5) from the quick-drain valve (6).
3. Place the hose from the quick-drain drainer assembly ([Figure 5-15](#)) into a suitable container for collecting the drained oil: 5.5 gallons (21L) of oil is required to fill a dry gearbox.
4. Thread the quick-drain drainer assembly all the way onto the quick-drain valve (6). The poppet inside the valve will open, allowing the oil to drain from the gearbox.
5. Once the gearbox has finished draining, remove the quick-drain drainer assembly.
6. Fasten the dust cap (5) to the quick-drain valve (6).
7. Fill the gearbox with specified oil:

MANUAL FILL PROCEDURE

- a. Check that valve (4) is open. It is used only for the power fill procedure.
- b. Remove the breather (1a) from the fill port (2).
- c. Add oil through the fill port (2) using a suitable funnel until the oil level is halfway up the sight glass (3). Do not overfill.
- d. Reinstall the breather (1a) in the fill port (2).

POWER FILL PROCEDURE (recommended)

- a. Close the shut off valve (4), or the oil will flow out the breather (1b).
- b. Remove the dust cap (5) from the quick-drain valve (6).
- c. Thoroughly clean the inside of the hose for the quick-drain drainer assembly.

- d. Thread the quick-drain drainer assembly all the way onto the quick-drain valve (6). The poppet inside the valve will open.
 - e. Connect the hose from the quick-drain drainer assembly to a portable pump, either hydraulically powered or hand powered.
 - f. Slowly pump oil into the gearbox until the oil level is halfway up the sight glass (3). Do not overfill.
 - g. Once the gearbox is filled, remove the quick-drain drainer assembly.
 - h. Fasten the dust cap (5) to the quick-drain valve (6).
 - i. Open the shut-off valve (4).
8. Recheck the oil level after operating the hoist. If necessary, add oil through the fill port (2).
 9. Thoroughly clean the quick-drain drainer assembly and store it in the parts box.

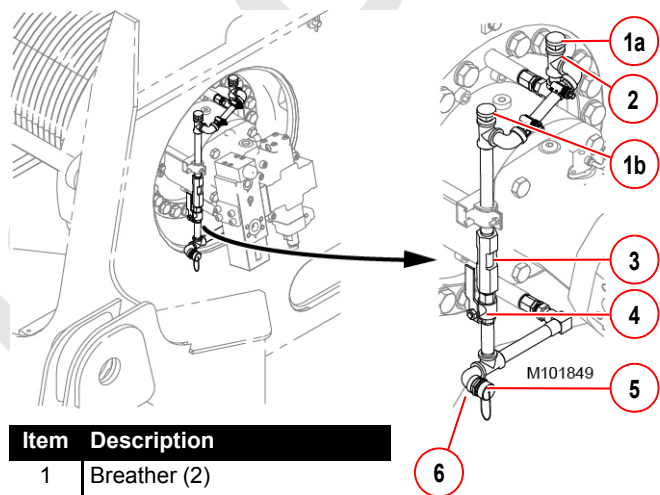

Figure 5-16. Front or Rear Free Fall Drum Gearbox

Drums 1 and 2 Gearbox without Free Fall Option

See [Figure 5-17](#) for the following instructions.

NOTE To prevent harmful contaminants from entering the gearbox, thoroughly clean components before disconnecting or connecting them.

1. Lock out/tag out the crane.
2. Remove the plug (1) to vent the gearbox.
3. Remove the dust cap (5) from the quick-drain valve (4).
4. Place the hose from the quick-drain drainer assembly ([Figure 5-15](#)) into a suitable container for collecting the drained oil: 5.5 gallons (21L) of oil is required to fill a dry gearbox.
5. Thread the quick-drain drainer assembly all the way onto the quick-drain valve (4). The poppet inside the valve will open, allowing the oil to drain from the gearbox.
6. Once the gearbox has finished draining, remove the quick-drain drainer assembly.
7. Fasten the dust cap (5) to the quick-drain valve (4).
8. Fill the gearbox with specified oil:

MANUAL FILL PROCEDURE

- a. If not already done, remove plug (1).
- b. Add oil through the fill port (2) using a suitable funnel until the oil level is halfway up the sight glass (3). Do not overfill.
- c. Install the plug (1).

POWER FILL PROCEDURE (recommended)

- a. Remove the plug (1) to vent the gearbox.
- b. Remove the dust cap (5) from the quick-drain valve (4).
- c. Thoroughly clean the inside of the hose for the quick-drain drainer assembly.
- d. Thread the quick-drain drainer assembly all the way onto the quick-drain valve (4). The poppet inside the valve will open.

- e. Connect the hose from the quick-drain drainer assembly to a portable pump, either hydraulically powered or hand powered.
 - f. Slowly pump oil into the gearbox until the oil level is halfway up the sight glass (3). Do not overfill.
 - g. Once the gearbox is filled, remove the quick-drain drainer assembly.
 - h. Fasten the dust cap (5) to the quick-drain valve (4).
 - i. Install the plug (1).
9. Recheck the oil level after operating the hoist. If necessary, add oil through the fill port (2).
 10. Thoroughly clean the quick-drain drainer assembly and store it in the parts box.

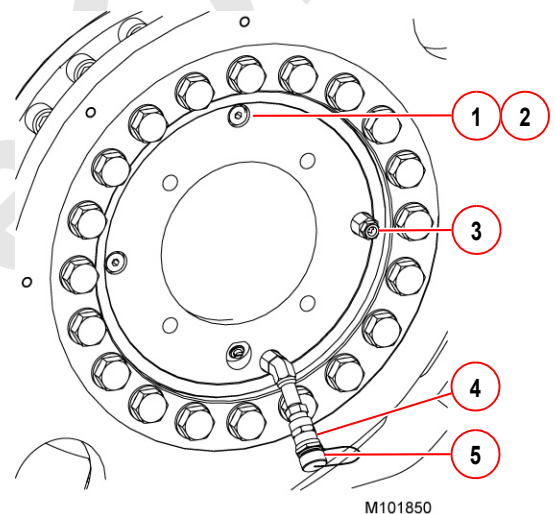

| Item | Description |
|------|-------------------|
| 1 | Plug |
| 2 | Fill Port |
| 3 | Sight Glass |
| 4 | Quick-Drain Valve |

Figure 5-17. Front or Rear Non-Free Fall Drum Gearbox

Drum 3 Gearbox**WARNING****Falling Boom Hazard**

Improperly lowering the boom can result in crane tipping and serious injury to personnel.

Before lowering the boom to ground level, read the Prepare Crane and Lower Boom topics in Section 4 of the MLC165-1 Operator Manual.

See [Figure 5-18](#) for the following instructions.

NOTE To prevent harmful contaminants from entering the gearbox, thoroughly clean components before disconnecting or connecting them.

CHECKING DRUM 3 OIL LEVEL

Boom butt at 0° (View A):

1. The oil level should be at the middle of the sight glass (3).

2. If necessary, remove the plug (1) and add oil through the fill port (2a).

3. Reinstall the plug (1).

Boom butt at 87° (View B):

1. Remove plug (1).

2. The oil level should be at the bottom of the level port (2b).

3. If necessary, remove the sight glass (3) and add oil through the fill port (7).

4. Reinstall the plug (1) and the sight glass (3).

Boom at 25° to 70° (View C):

1. The oil level — viewed in the sight tube (6) — should be on a horizontal line through the center of the gear box.

2. If necessary, remove the plug (1) and add oil through the fill port (2a).

3. Reinstall the plug (1).

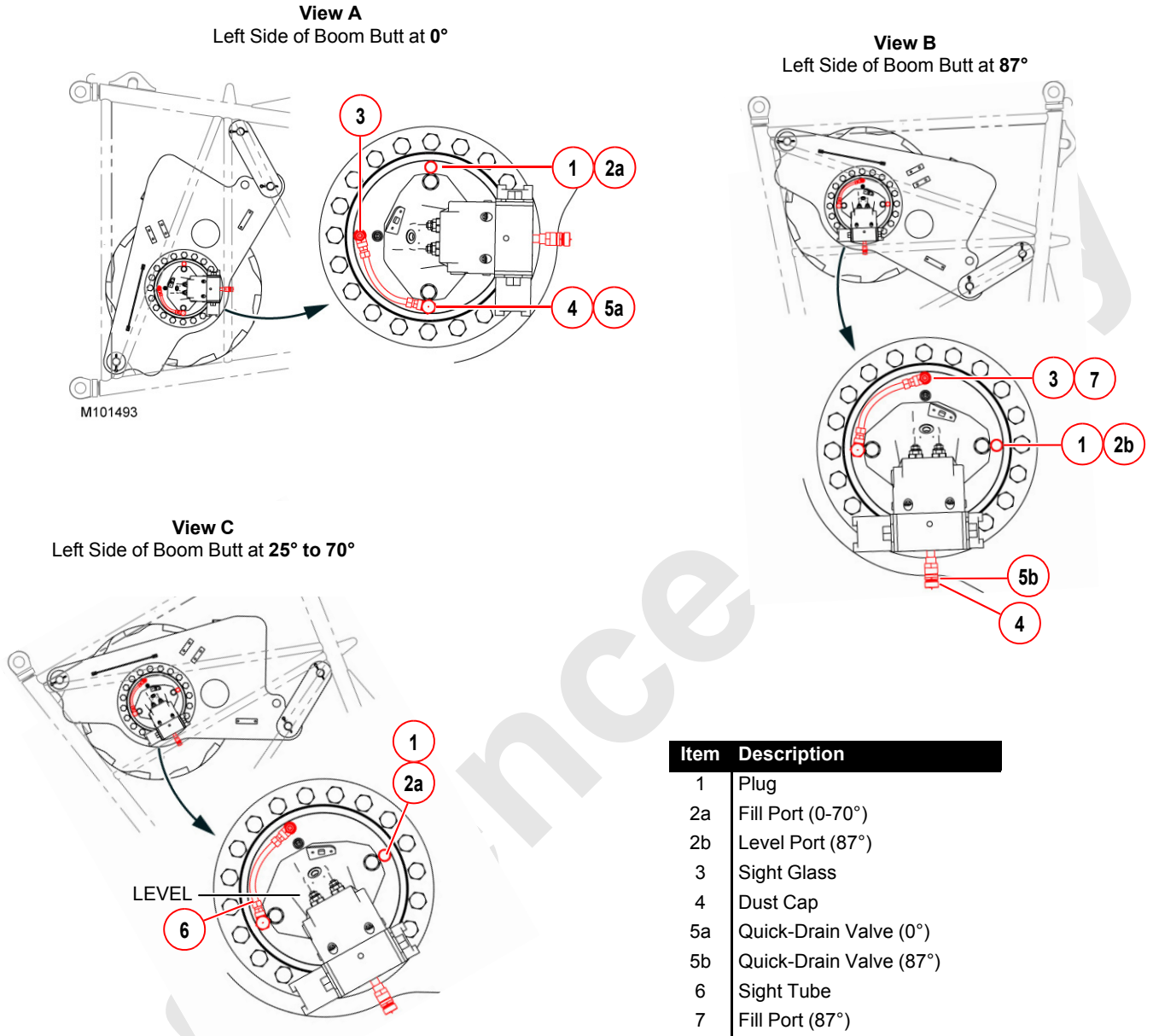

Figure 5-18. Drum 3

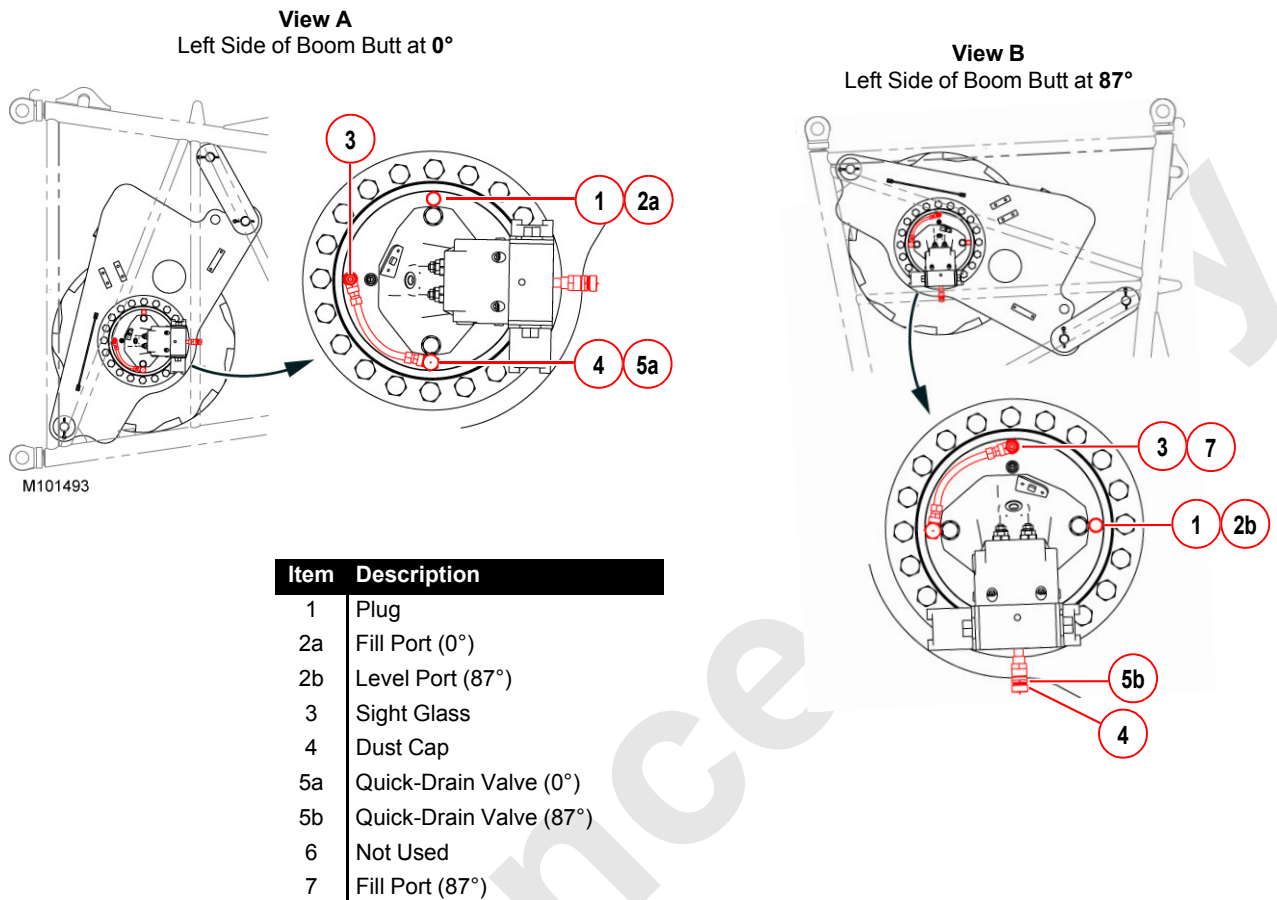

Figure 5-19. Drum 3

DRAINING DRUM 3 OIL WITH BOOM BUTT AT 0°

NOTE Refer to [page 5-25](#) for the draining procedure with the boom butt at 87°.

See [Figure 5-19](#), View A for the following procedure.

1. Lock out/tag out the crane.
2. Remove the plug (1) to vent the gearbox.
3. Remove the dust cap (4) from the quick-drain valve (5a).
4. Place the hose from the quick-drain drainer assembly ([Figure 5-15](#)) into a suitable container for collecting the drained oil: 2.3 gallons (8,5 L) of oil is required to fill a dry gearbox.
5. Thread the quick-drain drainer assembly all the way onto the quick-drain valve (5a). The poppet inside the valve will open, allowing the oil to drain from the gearbox.
6. Once the gearbox has finished draining, remove the quick-drain drainer assembly.

7. Fasten the dust cap (4) to the quick-drain valve (5a).
8. Fill the gearbox with specified oil:

MANUAL FILL PROCEDURE

- a. If not already done, remove the plug (1).
- b. Add oil through the fill port (2a) using a suitable funnel until the oil level is halfway up the sight glass (3). Do not overfill.
- c. Install the plug (1).

POWER FILL PROCEDURE (recommended)

- a. Remove the plug (1) to vent the gearbox.
- b. Remove the dust cap (4) from the quick-drain valve (5a).
- c. Thoroughly clean the inside of the hose for the quick-drain drainer assembly.

- d. Thread the quick-drain drainer assembly all the way onto the quick-drain valve (5a). The poppet inside the valve will open.
 - e. Connect the hose from the quick-drain drainer assembly to a portable pump, either hydraulically powered or hand powered.
 - f. Slowly pump oil into the gearbox until the oil level is halfway up the sight glass (3). Do not overfill.
 - g. Once the gearbox is filled, remove the quick-drain drainer assembly.
 - h. Fasten the dust cap (4) to the quick-drain valve (5a).
 - i. Install the plug (1).
9. Recheck the oil level after operating the hoist. If necessary, add oil through the fill port (2a).
 10. Thoroughly clean the quick-drain drainer assembly and store it in the parts box.

DRAINING DRUM 3 OIL WITH BOOM BUTT AT 87°

See [Figure 5-19](#), View B for the following procedure.

1. Lock out/tag out the crane.
2. Remove the sight glass (3) to vent the gearbox.
3. Remove the dust cap (4) from the quick-drain valve (5b).
4. Place the hose from the quick-drain drainer assembly ([Figure 5-15](#)) into a suitable container for collecting the drained oil: 2.3 gallons (8,5 L) of oil is required to fill a dry gearbox.
5. Thread the quick-drain drainer assembly all the way onto the quick-drain valve (5b). The poppet inside the valve will open, allowing the oil to drain from the gearbox.
6. Once the gearbox has finished draining, remove the quick-drain drainer assembly.
7. Fasten the dust cap (4) to the quick-drain valve (5b).

8. Fill the gearbox with specified oil:

MANUAL FILL PROCEDURE

- a. If not already done, remove the sight glass (3).
- b. Remove the plug (1).
- c. Add oil through the fill port (7) using a suitable funnel until the oil level is at the bottom of the level port (2b). Do not overfill.
- d. Install the plug (1).
- e. Install the sight glass (3).

POWER FILL PROCEDURE (recommended)

- a. Remove the plug (1).
 - b. Remove the dust cap (4) from the quick-drain valve (5b).
 - c. Thoroughly clean the inside of the hose for the quick-drain drainer assembly.
 - d. Thread the quick-drain drainer assembly all the way onto the quick-drain valve (5b). The poppet inside the valve will open.
 - e. Connect the hose from the quick-drain drainer assembly to a portable pump, either hydraulically powered or hand powered.
 - f. Slowly pump oil into the gearbox until the oil level is at the bottom of level port (2b). Do not overfill.
 - g. Once the gearbox is filled, remove the quick-drain drainer assembly.
 - h. Fasten the dust cap (4) to the quick-drain valve (5b).
 - i. Install the plug (1).
9. Recheck the oil level after operating the hoist. If necessary, add oil through the fill port (7).
 10. Thoroughly clean the quick-drain drainer assembly and store it in the parts box.

Drum 4 Gearbox

See [Figure 5-20](#) for the following procedure.

NOTE To prevent harmful contaminants from entering the gearbox, thoroughly clean components before disconnecting or connecting them.

1. Lock out/tag out the crane.
2. Remove the plug (1) to vent the gearbox.
3. Remove the dust cap (5) from the quick-drain valve (4).
4. Place the hose from the quick-drain drainer assembly ([Figure 5-15](#)) into a suitable container for collecting the drained oil: 2.3 gallons (8,5 L) of oil is required to fill a dry gearbox.
5. Thread the quick-drain drainer assembly all the way onto the quick-drain valve (4). The poppet inside the valve will open, allowing the oil to drain from the gearbox.
6. Once the gearbox has finished draining, remove the quick-drain drainer assembly.
7. Fasten the dust cap (5) to the quick-drain valve (4).
8. Fill the gearbox with specified oil:

MANUAL FILL PROCEDURE

- a. If not already done, remove the plug (1).
- b. Add oil through the fill port (2) using a suitable funnel until the oil level is halfway up the sight glass (3). Do not overfill.
- c. Install the plug (1).

POWER FILL PROCEDURE (recommended)

- a. Remove the plug (1) to vent the gearbox.
- b. Remove the dust cap (5) from the quick-drain valve (4).
- c. Thread the quick-drain drainer all the way onto the quick-drain valve (4). The poppet inside the valve will open.
- d. Connect the hose from the quick-drain drainer assembly to a portable pump, either hydraulically powered or hand powered.

- e. Slowly pump oil into the gearbox until the oil level is halfway up the sight glass (3). Do not overfill.
- f. Once the gearbox is filled, remove the quick-drain drainer assembly.
- g. Fasten the dust cap (5) to the quick-drain valve (4).
- h. Install the plug (1).
9. Recheck the oil level after operating the hoist. If necessary, add oil through the fill port (2).
10. Thoroughly clean the quick-drain drainer assembly and store it in the parts box.

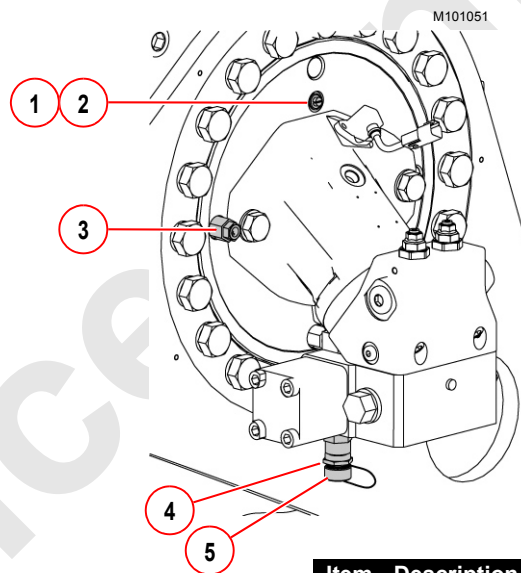

| Item | Description |
|------|-------------------|
| 1 | Plug |
| 2 | Fill Port |
| 3 | Sight Glass |
| 4 | Quick-Drain Valve |
| 5 | Dust Cap |

Figure 5-20. Drum 4

Reference Only

THIS PAGE INTENTIONALLY LEFT BLANK

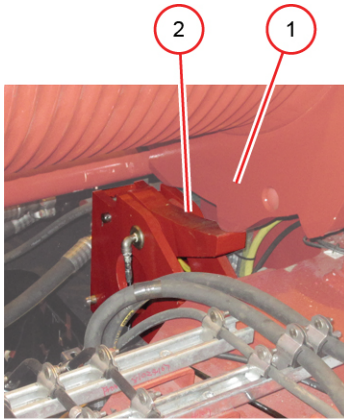

View at Front of Rotating Bed

| Item | Description |
|------|---------------------------|
| 1 | Drum Ratchet |
| 2 | Pawl |
| 3 | Cam |
| 4 | Apply grease to this area |
| 5 | Spring |
| 6 | Eyebolt |
| 7 | Hydraulic Cylinder |

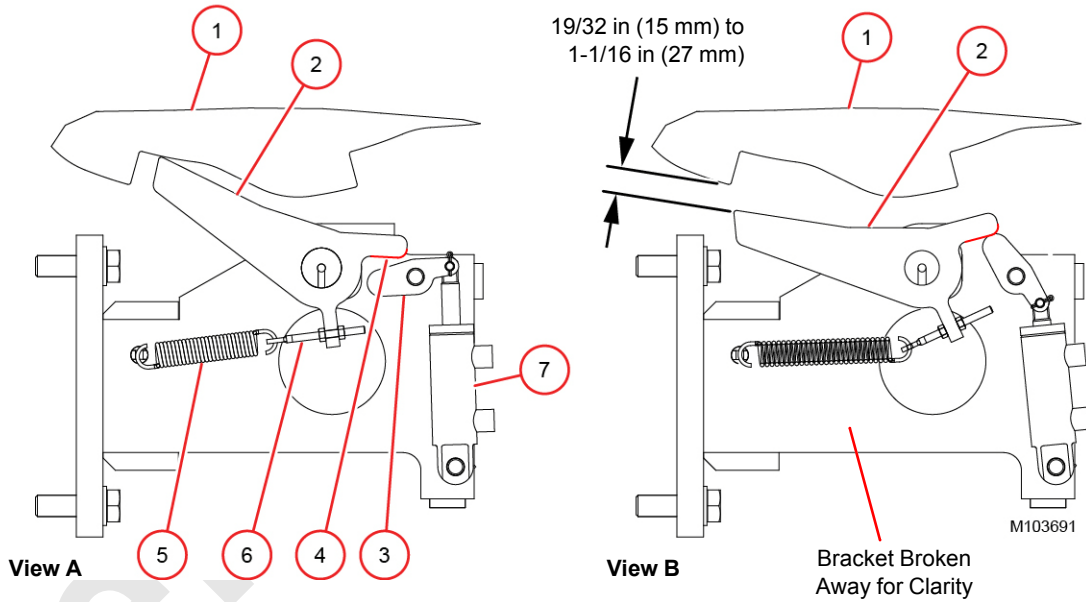

Figure 5-21. Drum 1 Pawl

DRUM 1 PAWL



WARNING

Falling Boom Hazard

Before performing the steps in this section, land the loads and lower the boom onto blocking at ground level. There is no positive means of holding the boom up when the pawl is being serviced.

See [Figure 5-21](#)

Drum 1 (front load drum) has a pawl which, when engaged, prevents the drum from turning in the down direction.

Drum 2 does not have a pawl.

Operation

The pawl is controlled by a park switch in the operator cab:

When Drum 1 Park is turned **on**, the pawl engages (View A). The hydraulic cylinder (7) extends and the spring (5) force rotates the pawl (2) into engagement with the drum ratchet (1).

When Drum 1 Park is turned **off**, the pawl disengages (View B). The hydraulic cylinder (7) retracts and the cam (3) rotates the pawl (2) out of engagement with the drum ratchet (1).

It may be necessary to hoist slightly to fully disengage the pawl from the drum ratchet.

Maintenance

Daily

Visually check the pawl for proper operation according to the following procedure.

1. Operate Drum 1 for a short distance, stop the drum, and place the Drum 1 Park switch in the **on** position.
 - Check that the pawl is fully engaged into the ratchet of the drum. Adjust spring tension if necessary.
 - Check that the drum is inoperable in the down direction.
2. Place the Drum 1 Park switch in the **off** position.
 - Check that the pawl is disengaged from the ratchet at the dimension shown in View B.
 - Check that the drum is operable in the down direction.

Weekly

Apply a small amount of grease (open gear lube) to the sliding surfaces (4). Wipe off any excess grease.

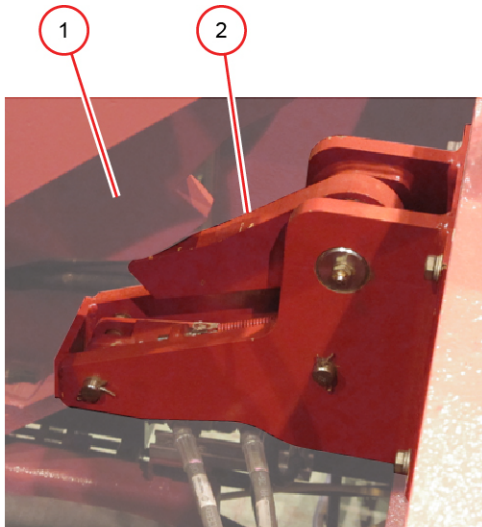

View at Boom Hoist Drum on Top of Rotating Bed

| Item | Description |
|------|---------------------------|
| 1 | Drum Ratchet |
| 2 | Pawl |
| 3 | Cam |
| 4 | Apply grease to this area |
| 5 | Spring |
| 6 | Eyebolt |
| 7 | Hydraulic Cylinder |

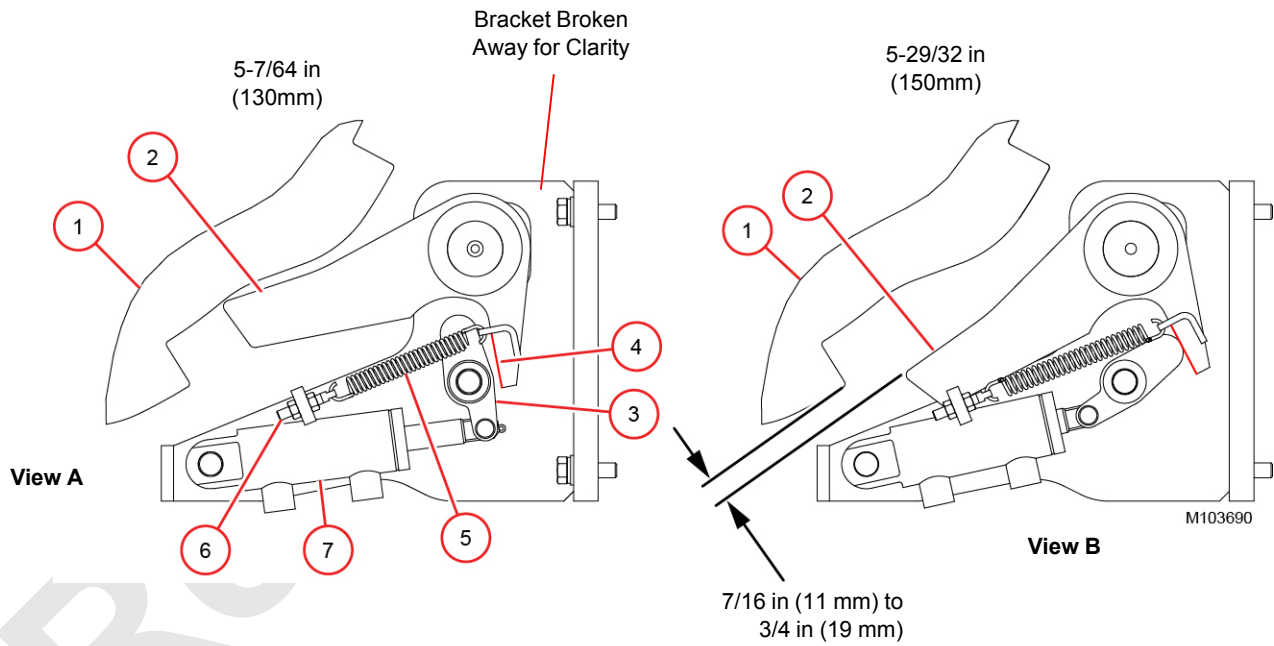

Figure 5-22. Drum 4 Pawl

DRUM 4 PAWL



WARNING

Falling Boom Hazard

Before performing the steps in this section, land the loads and lower the boom onto blocking at ground level. There is no positive means of holding the boom up when the pawl is being serviced.

See [Figure 5-22](#)

Drum 4 (boom hoist) has a pawl which, when engaged, prevents the drum from turning in the down direction.

Operation

The pawl is controlled by a park switch in the operator cab:

When Drum 4 Park is turned **on**, the pawl engages (View A). The hydraulic cylinder (7) extends and the spring (5) force rotates the pawl (2) into engagement with the drum ratchet (1).

When Drum 4 Park is turned **off**, the pawl disengages (View B). The hydraulic cylinder (7) retracts and the cam (3) rotates the pawl (2) out of engagement with the drum ratchet (1).

It may be necessary to boom up slightly to fully disengage the pawl from the drum ratchet.

Maintenance

Daily

Visually check the pawl for proper operation according to the following procedure.

1. Operate Drum 4 for a short distance, stop the drum, and place the Drum 4 Park switch in the **on** position.
 - Check that the pawl is fully engaged into the ratchet of the drum. Adjust spring tension if necessary.
 - Check that the drum is inoperable in the down direction.
2. Place the Drum 4 Park switch in the **off** position.
 - Check that the pawl is disengaged from the ratchet at the dimension shown in View B.
 - Check that the drum is operable in the down direction.

Weekly

Apply a small amount of grease (open gear lube) to the sliding surfaces (4). Wipe off any excess grease.

DRUM 3 PAWL

WARNING

Falling Boom Hazard

Before performing the steps in this section, land the loads and lower the boom onto blocking at the ground level. There is no positive means of holding the boom up when the pawl is being serviced.

Drum 3 (optional auxiliary/luffing hoist) has a pawl which, when engaged, prevents the drum from turning in the down direction.

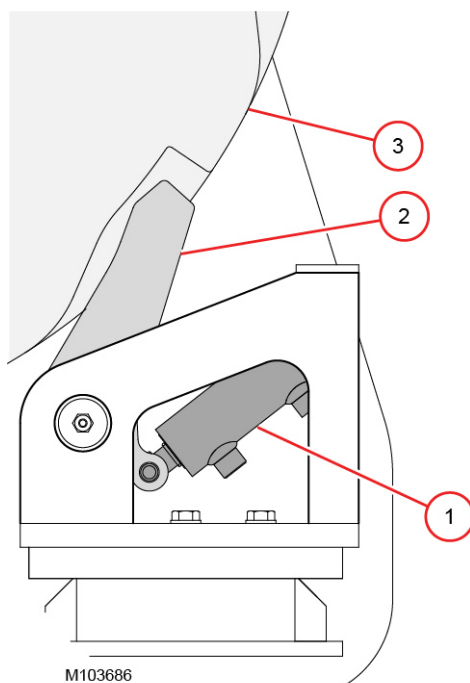

| Item | Description |
|------|--------------------|
| 1 | Hydraulic Cylinder |
| 2 | Pawl |
| 3 | Drum Ratchet |

Figure 5-23. Drum 3 Pawl

Operation

WARNING

Falling Boom Hazard

Before performing the steps in this section, land the loads and lower the boom onto blocking at the ground level. There is no positive means of holding the boom up when the pawl is being serviced.

Figure 5-23

The pawl is controlled by a park switch in the operator cab:

When Drum 3 Park is turned **on**, the hydraulic cylinder (1) retracts and rotates the pawl (2) into engagement with the ratchet (3).

When Drum 3 Park is turned **off**, the hydraulic cylinder (1) extends and rotates the pawl (2) out of engagement with the ratchet (3).

It may be necessary to hoist slightly to fully disengage the pawl from the ratchet.

Maintenance

Daily

Visually check the pawl for proper operation according to the following procedure.

- Operate Drum 3 for a short distance, stop the drum, and place the Drum 3 Park switch on the **on** position.
 - Check that the pawl is fully engaged into the ratchet of the drum.
 - Check that the drum is inoperable in the down direction.
- Place the Drum 3 Park switch in the **off** position.
 - Check that the pawl is disengaged from the ratchet.
 - Check that the drum is operable in the down direction.

Monthly

- Apply 1/2 pump of grease to the fitting in the pawl pin.
- Wipe off any excess grease in the area.

Adjustment

There is no adjustment for this pawl.

| Item | Description |
|------|--|
| 1 | Speed Sensor (with O-ring) |
| 2 | Screw (2) |
| 3 | Hoist Motor |
| 4 | Sensor Cable |
| 5 | Drain Plug (when motor is positioned with sensor underneath) |

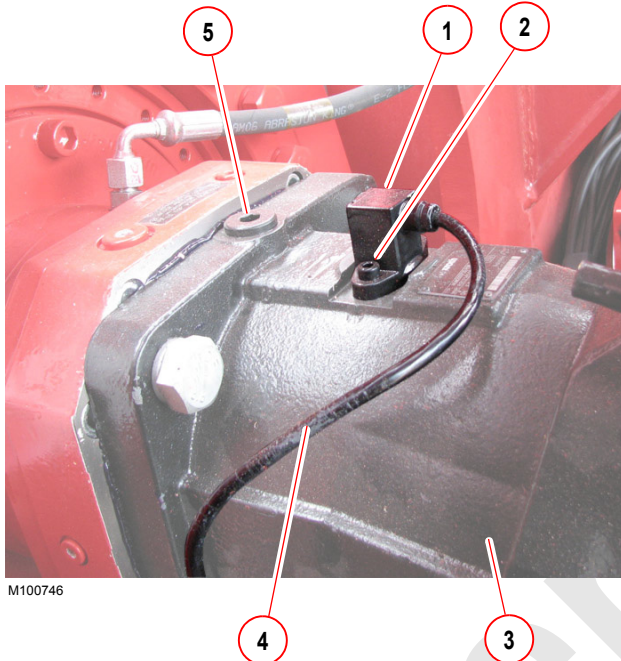

Figure 5-24. Motor Speed Sensor

SPEED SENSOR—HOIST MOTORS

[Figure 5-24](#)

A speed sensor (1) is installed in each non-free fall hoist motor. The sensor sends rotational speed and direction information to the master controller to be used by the crane control functions.

There is no adjustment for the speed sensor.

Replacement

! WARNING **Burn Hazard**

Oil will drain from the port when the sensor is removed. Wait for the hydraulic oil to cool before removing the sensor.

1. Stop the engine and wait for the hydraulic oil to cool.
2. Disconnect the sensor cable (4) from the wire harness.
3. Thoroughly clean all around the sensor to prevent dirt from entering the hydraulic system.
4. On motors positioned so that the sensor is on the underside of the motor, place a suitable container under the drain plug (5) and remove the drain plug.
5. Remove the two sensor mounting screws (2).
6. Remove the faulty sensor (1) with O-ring. Be careful to contain any hydraulic fluid that might drain from the motor.
7. Clean the mating surfaces, then install a new sensor and O-ring.
8. Install the mounting screws to the correct torque value for the size screw.
9. Re-connect the sensor cable to the wire harness.
10. On motors positioned so that the sensor is on the underside of the motor:
 - a. Make sure that the drain plug is clean, then install the drain plug.
 - b. Thoroughly clean all around the fill plug, then remove the fill plug.
 - c. Fill the motor with filtered hydraulic oil of the proper type.
 - d. Make sure that the fill plug is clean, then re-install the fill plug.
11. Start the engine and operate the hoist.
12. Check for a steady drum speed (rpm) and direction signal on the corresponding drum's information display in cab.
13. Make sure there is no leakage.

THIS PAGE INTENTIONALLY LEFT BLANK

Reference Only

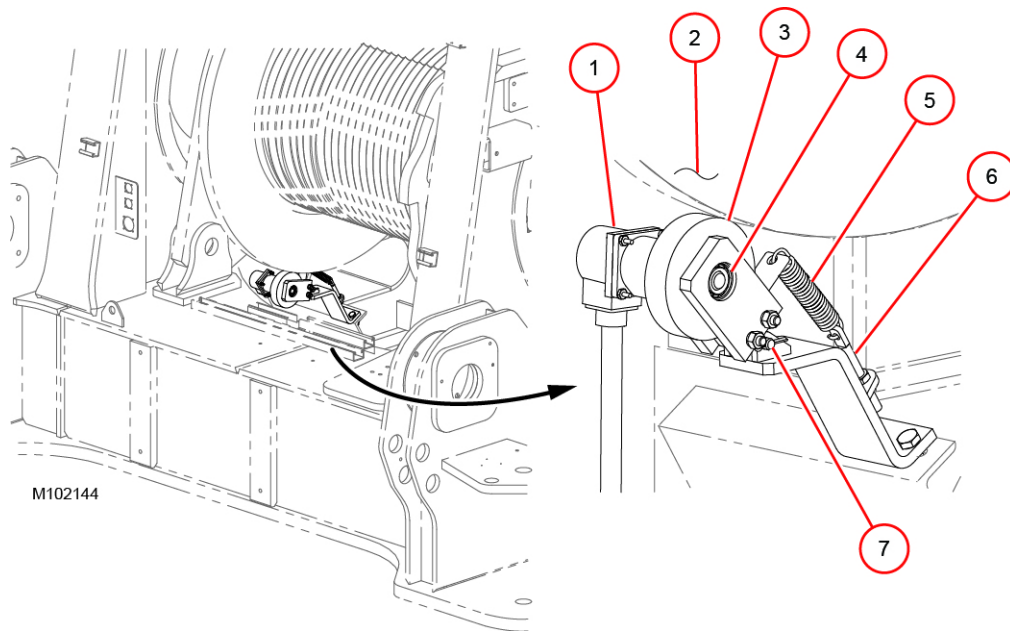

M102144

| Item | Description |
|------|------------------------------------|
| 1 | Optical Encoder |
| 2 | Drum Flange |
| 3 | Indicator Wheel and Shaft Assembly |
| 4 | Bearings (2) |
| 5 | Spring |
| 6 | Eyebolt |
| 7 | Pin and Cotter Pin |

Figure 5-25. Speed Sensor Assembly

SPEED SENSOR—FREE FALL DRUMS

[Figure 5-25](#)

The hoist drum assemblies (Drums 1 and 2) equipped with the free fall option have a sensor that sends a rotational speed and direction signal to the controller in the universal node.

Maintenance

Daily, Prior to Free Fall Work

Verify the proper operation of the speed sensor according to the following procedure.

1. Check that all speed sensor assembly parts, wiring, and connections are secure and undamaged.

2. Check that the indicator wheel is centered on the drum flange and firmly in contact. If needed, increase spring tension.
3. Check that the indicator wheel spins freely.
4. Enable free fall operation according to instructions in the MLC165-1 Operator Manual.
5. Operate the hoist and verify that there is a reliable speed readout in the main display. If there is intermittent or no readout, troubleshoot the speed sensor assembly.
6. At initial installation of the speed sensor, adjust the eyebolt (6) so the roller (3) is tight against the drum flange (2).

If any part is damaged or doesn't work properly, repair as needed.

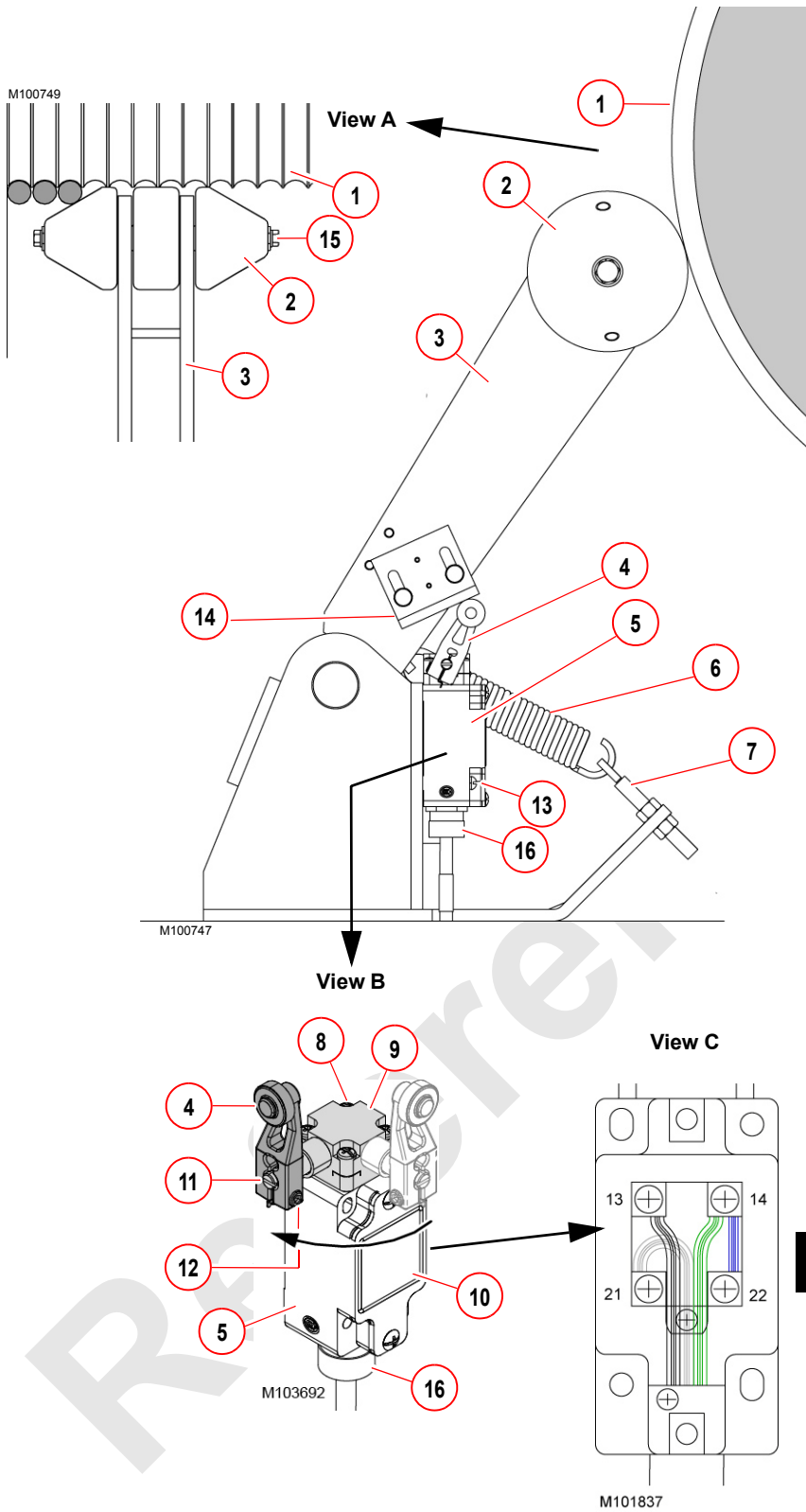

| Item | Description |
|------|------------------------------------|
| 1 | Auxiliary Drum |
| 2 | Bail Limit Rollers |
| 3 | Lever |
| 4 | Limit Switch Arm |
| 5 | Limit Switch |
| 6 | Spring (2) |
| 7 | Eyebolt (2) |
| 8 | Screw (4) |
| 9 | Limit Switch Head |
| 10 | Limit Switch Cover |
| 11 | Limit Switch Shaft |
| 12 | Screw (9/64 in socket) |
| 13 | Screw and Washer (4) |
| 14 | Actuator Bracket |
| 15 | Cap Screw (2) |
| 16 | Cable Connector |
| A | View of Rollers Against Bare Drum |
| B | View of Limit Switch |
| C | View of Wiring Inside Limit Switch |

| Limit Switch Wiring | | |
|---------------------|-----------------|---------------|
| Wire Color | Switch Terminal | Function |
| Black | 13 | N/O |
| Green | 14 | 24 VDC Supply |
| White | 21 | N/C |
| Blue | 14-22 | Jumper |

Figure 5-26. Minimum Bail Limit Assembly (Drum 3)

MINIMUM BAIL LIMIT (DRUM 3)

See [Figure 5-26](#) for the following procedure.

The OPTIONAL minimum bail limit is a protective device which automatically stops the auxiliary drum (Drum 3) when there are 3 to 4 wraps of wire rope remaining on the first layer of the auxiliary drum (View A).

The auxiliary drum can be operated in the hoist direction when the minimum bail limit switch is tripped open.



WARNING

Falling Load Hazard

Do not operate the auxiliary drum with less than 3 or 4 full wraps of wire rope remaining on the drum. Doing so can cause the wire rope to be pulled out of the drum and the load to fall.

Field adjustment should not be necessary unless a new limit switch is installed.

Limit Switch Replacement

Removal

1. Land the load from the auxiliary drum.
2. Stop the engine.
3. Remove the screws (13) and remove the limit switch (5).
4. Remove the limit switch cover (10).
5. Disconnect the electric wires, including the jumper wire, inside the limit switch (5, View C).
6. Unscrew the cable connector (16) and carefully pull the electric cable and wires away from the limit switch (5).
7. Loosen the screw (12) and remove the limit switch arm (4) from the limit switch (5).

Installation

1. Connect the electric wires to the new limit switch (5):
 - a. Remove the limit switch cover (10).
 - b. Install the wires, including the jumper wire, and connect them to the correct terminals in the limit switch (View C).
 - c. Securely tighten the cable connector (16) to the limit switch (5).
 - d. Install the limit switch cover (10).

2. If needed, re-orient the limit switch head (9, View B):
 - a. Remove the screws (8).
 - b. Rotate the limit switch head (9) to the position shown in View B.
 - c. Reinstall the screws (8).
3. Install the limit switch arm (4) onto the limit switch shaft (5) as shown in View B. Do not tighten the screw (12) yet.
4. Using the screws (13), install the limit switch (5).

Adjustment

1. Start the engine.
2. Pay out the wire rope from the auxiliary drum until the bail limit rollers (2) are against the bare drum with 3 to 4 full wraps of the wire rope remaining on the drum (View A).
3. Hold the roller on the limit switch arm (4) against the actuator bracket (14).
4. Turn the limit switch shaft (11) counterclockwise (when viewing the shaft) only enough to click the limit switch open, then hold the shaft.
5. Securely tighten the screw (12, View B) to secure the limit switch arm (4) to the limit switch shaft (11).
6. Test the installation:
 - a. Spool six to seven wraps of wire rope onto the auxiliary drum.
 - b. Pay out the wire rope.
 - c. The drum must stop when there are three to four wraps of wire rope remaining on the drum.
 - d. If necessary, repeat the adjustment.

Weekly Maintenance

Check the minimum bail limit switch for proper operation:

1. Pay out the wire rope from the auxiliary drum (1). The drum should stop when there are 3 to 4 wraps of the wire rope remaining on the first layer. Adjust the limit switch (5) if necessary.
2. Check that the cap screws (15) are tight.
3. Check that the springs (6) have sufficient tension to hold the bail limit rollers against the bare drum. To increase the spring tension, adjust the eyebolts (7) as needed.

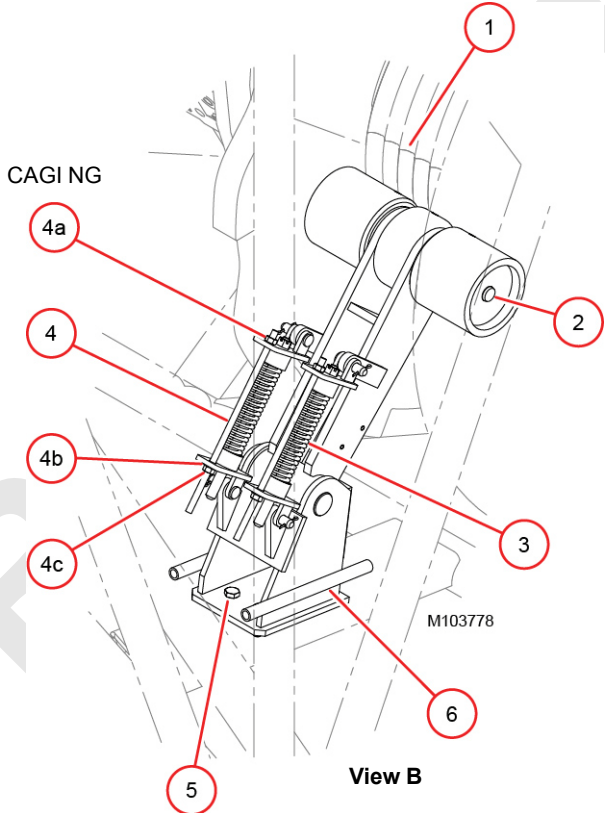
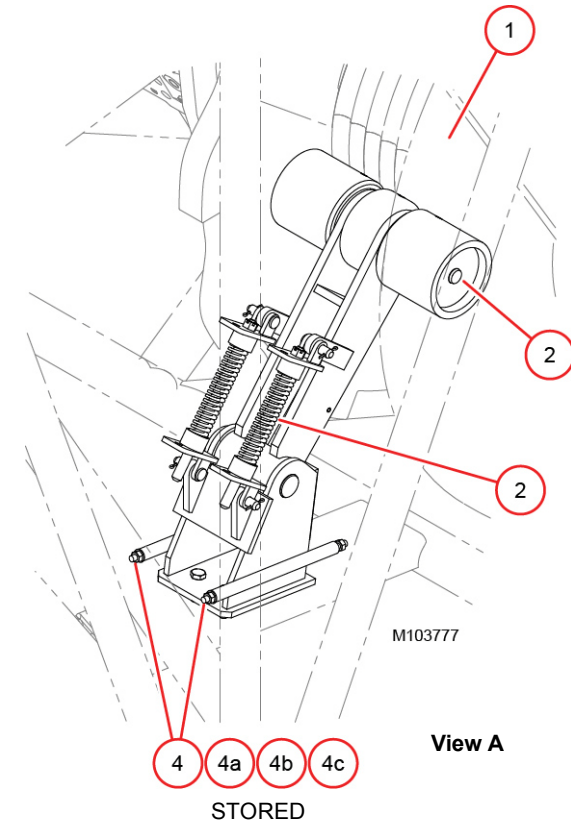

| Item | Description |
|----------|---|
| 1 | Drum 3 |
| 2 | Pressure Rollers |
| 3 | Spring (2) |
| 4 | Compression Rod (threaded)(2) |
| 4a | Hex Nut (4) |
| 4b | Flat Washer (2) |
| 4c | Hex Nut (4) |
| 5 | Screw with Washer and Nut (4) |
| 6 | Bracket |
| A | View of Pressure Roller Assembly Installed |
| B | View of Pressure Roller Assembly Compressed for Servicing |

Figure 5-27. Pressure Roller (Drum 3)

Pressure Roller (Drum 3)

See [Figure 5-27](#) for the following procedure.

Daily Maintenance

NOTE The springs (3) for the drum pressure rollers (2) are not adjustable.

1. Watch the pressure rollers (2, View A) while paying out and hauling in the wire rope on the drum (1).

The springs (3) must hold the pressure rollers (2) snugly against all layers of wire rope on the drum — from the first layer to the last layer.

2. Replace the springs (3) if they lose tension.



WARNING

Flying Object Hazard

The pressure roller springs for Drum 3 are pre-loaded.

Do not attempt to remove the Drum 3 pressure roller assembly until the springs are compressed.

Parts will fly apart with violent force if this precaution is ignored.

Spring Replacement

1. Land the load on the drum and stop the engine.
2. Remove the compression rods (4, View A) from storage.
3. Assemble the compression rods (4) in the caging position (View B).
4. Tighten the hex nuts (4c), alternating from side to side, until the springs (3) are compressed and the pressure

rollers (2) are pulled away from the wire rope on the drum.

5. Attach lifting slings from a hoist to the pressure roller assembly. It weighs 66 lb (30 kg).
6. Remove the screws (5, View B) and lift the pressure roller assembly away from the drum (1).
7. Loosen the hex nuts (4c, View B), alternating from side to side, until the pre-load of the springs (3) is fully released.
8. Disassemble the pressure roller assembly as needed to replace parts.
9. Reassemble the pressure roller assembly.
10. Assemble the compression rods (4) in the caging position (View B).
11. Tighten the hex nuts (4c), alternating from side to side, until the springs (3) are compressed.
12. Attach lifting slings from a hoist to the pressure roller assembly. It weighs 66 lb (30 kg).
13. Lift the pressure roller assembly into position at the mounting plate.
14. Apply Loctite® 243 to the threads of the cap screws (5).
15. Install the screws (5) to attach the bracket (6) to the mounting plates.
If necessary, tighten the hex nuts (4c), alternating from side to side, to further compress the springs (3).
16. Fully loosen hex nuts (4c), alternating from side to side.
17. Remove the compression rods (4) from the caging position (View B).
18. Store the compression rods (4, View A).

MINIMUM BAIL LIMITS AND PRESSURE ROLLERS (DRUMS 1 AND 2)

The optional minimum bail limits and pressure rollers for the front and rear drums are identified in [Figure 5-28](#).

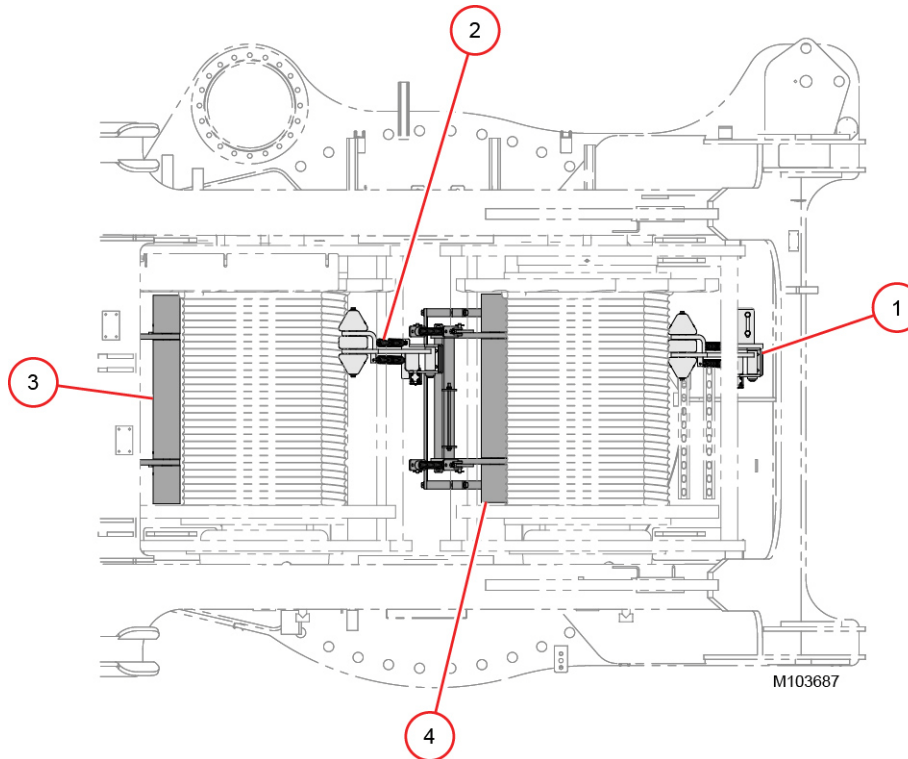

| Item | Description | Note |
|------|-------------------------------------|---|
| 1 | Drum 1 (front drum) Bail Limit | See Minimum Bail Limit (Drum 1 and 2) on page 5-43. |
| 2 | Drum 2 (rear drum) Bail Limit | See Minimum Bail Limit (Drum 1 and 2) on page 5-43. |
| 3 | Drum 2 (rear drum) Pressure Roller | See Pressure Roller (Drum 2) on page 5-45. |
| 4 | Drum 1 (front drum) Pressure Roller | See Pressure Roller (Drum 1) on page 5-45. |

Figure 5-28. Minimum Bail Limits and Pressure Rollers (Drums 1 and 2)

Reference Only

THIS PAGE INTENTIONALLY LEFT BLANK

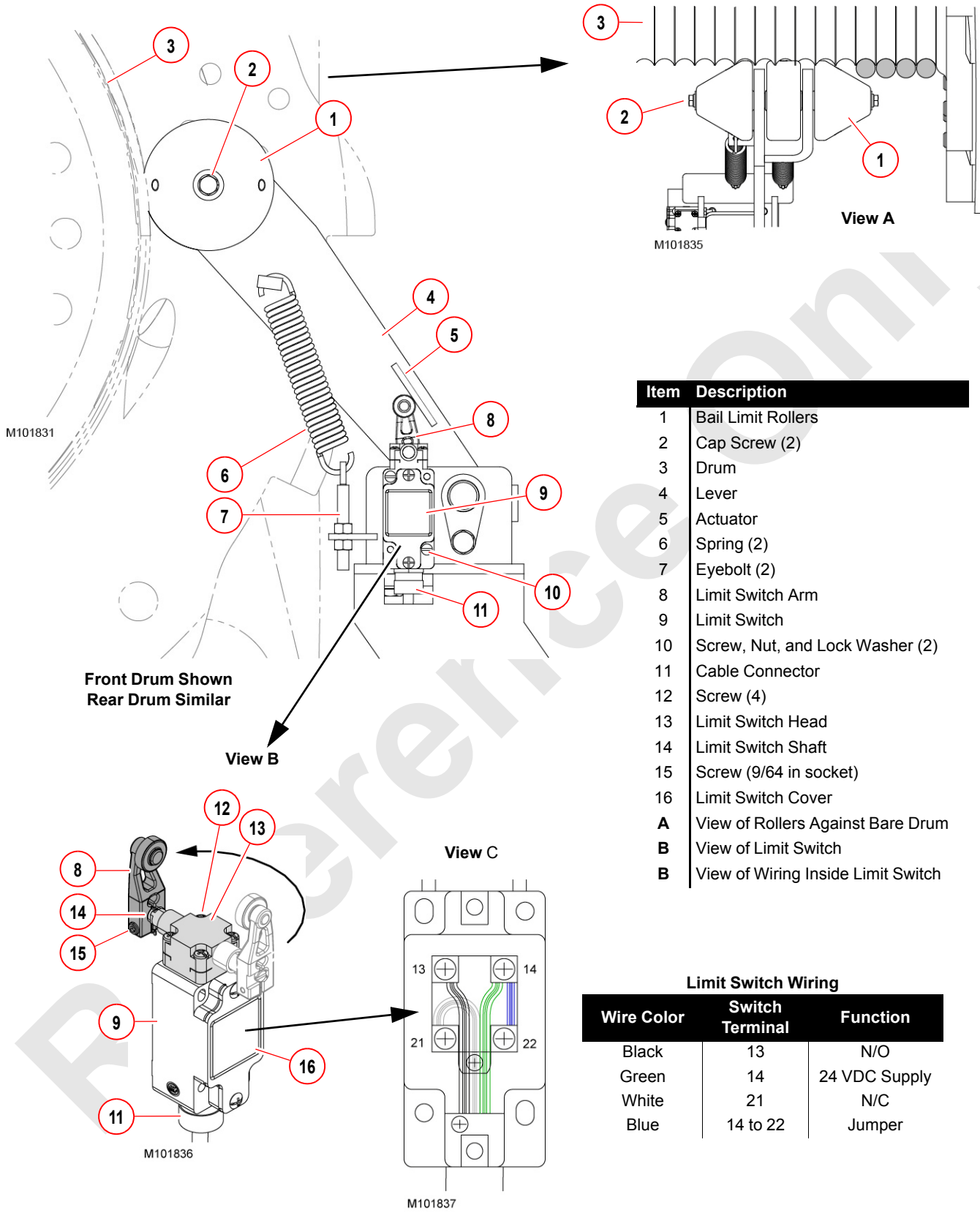

Figure 5-29. Minimum Bail Limit (Front or Rear Drum)

MINIMUM BAIL LIMIT (DRUM 1 AND 2)

See [Figure 5-29](#) for the following instructions.

The minimum bail limit for the front drum is shown. The minimum bail limit for the rear drum is similar. The following procedures apply to both drums.

The OPTIONAL minimum bail limit is a protective device which automatically stops the corresponding drum when there are 3 to 4 wraps of wire rope remaining on the first layer of the drum (View A).

The drum can be operated in the hoist direction when the minimum bail limit switch is tripped open.



WARNING

Falling Load Hazard

Do not operate the drum with less than 3 or 4 full wraps of wire rope remaining on the drum. Doing so can cause the wire rope to be pulled out of the drum and the load to fall.

Limit Switch Replacement

Field adjustment should not be necessary unless a new limit switch is installed.

Removal

1. Land the load from the drum being adjusted.
2. Stop the engine.
3. Remove the screws (10) and the limit switch (9).
4. Remove the limit switch cover (16).
5. Disconnect the electric wires, including the jumper wire, inside the limit switch (9, View C).
6. Unscrew the cable connector (11) and carefully pull the electric cable and wires away from the limit switch (9).
7. Loosen the screw (15) and remove the limit switch arm (8) from the limit switch shaft (14).

Installation

1. Connect the electric wires to the new limit switch:
 - a. Remove the limit switch cover (16).
 - b. Install the wires, including the jumper wire, and connect them to the correct terminals in the limit switch (View C).
 - c. Securely tighten the cable connector (11) to the limit switch (9).

- d. Install the limit switch cover (16).

2. If needed, re-orient the limit switch head (13, View B):
 - a. Remove the screws (12).
 - b. Rotate the limit switch head (13) to the position shown in View B.
 - c. Reinstall the screws (12).
3. Install the limit switch arm (8) onto the limit switch shaft (14) as shown in View B. Do not tighten the screw (15) yet.
4. Using the screws (10), install the limit switch (9).

Adjustment

1. Start the engine.
2. Pay out the wire rope from the corresponding drum until the bail limit rollers (1) are against the bare drum (3) with 3 to 4 full wraps of the wire rope remaining on the drum (View A).
3. Hold the roller on the limit switch arm (8) against the actuator (5).
4. Turn the limit switch shaft (14) toward the actuator only enough to click the limit switch (9) open, then hold the shaft.
5. Securely tighten the screw (15, View B) to secure the limit switch arm (8) to the limit switch shaft (14).
6. Test the installation:
 - a. Spool six to seven wraps of wire rope onto the load drum.
 - b. Pay out the wire rope.
 - c. The drum must stop when there are three to four wraps of wire rope remaining on the drum.
 - d. If necessary, repeat the adjustment.

Weekly Maintenance

Check the minimum bail limit switch for proper operation:

1. Pay out the wire rope from the drum (3). The drum should stop when there are 3 to 4 wraps of the wire rope remaining on the first layer. Adjust the minimum bail limit if necessary.
2. Check that the cap screws (2) are tight.
3. Check that the springs (6) have sufficient tension to hold the bail limit rollers (1) against the bare drum (3). To increase the spring tension, adjust the eyebolts (7) as needed.

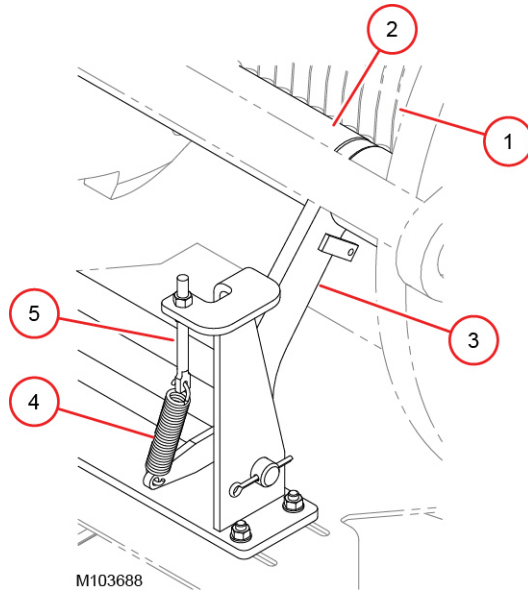

| Item | Description |
|------|------------------|
| 1 | Rear Drum |
| 2 | Pressure Rollers |
| 3 | Lever |
| 4 | Spring (2) |
| 5 | Eyebolt (2) |

Figure 5-30. Pressure Roller (Drum 2)

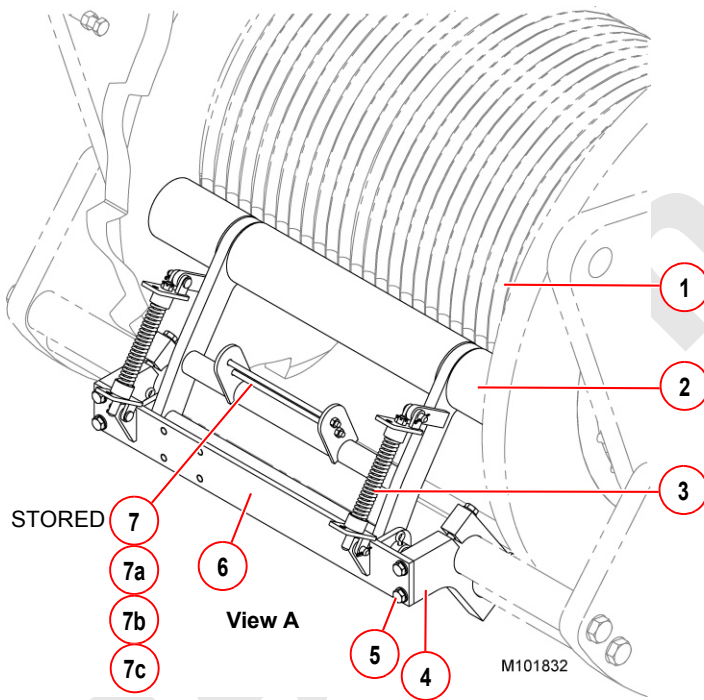

| Item | Description |
|------|--|
| 1 | Front Drum |
| 2 | Pressure Rollers |
| 3 | Spring (2) |
| 4 | Mounting Plate (2) |
| 5 | Cap Screw with Flat Washer (4) |
| 6 | Pressure Roller Bracket |
| 7 | Compression Rod (threaded)(2) |
| 7a | Hex Nut (2) |
| 7b | Flat Washer (2) |
| 7c | Hex Nut (2) |
| A | View of Pressure Roller Assembly Installed |
| B | View of Pressure Roller Assembly Compressed for Installation and Removal |

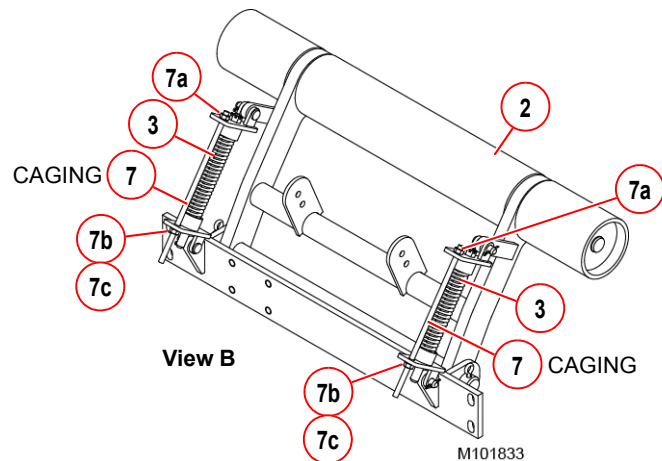

Figure 5-31. Pressure Roller (Drum 1)

PRESSURE ROLLER (DRUM 1 AND 2)

The OPTIONAL pressure roller is a protective device which prevents the wire rope from jumping wraps on the corresponding drum (Drum 1 or 2) or from jumping off the corresponding drum.

CAUTION

Prevent Wire Rope Damage

If equipped, make sure the pressure roller springs are tight enough to hold the rollers snugly against all layers of wire rope on the drum — from the first layer to the last layer.

Pressure Roller (Drum 2)

See [Figure 5-30](#) for the following instructions.

Observe the pressure roller daily for proper operation.

1. Watch the pressure rollers (2) while paying out and hauling in the wire rope on the rear drum (1).

The springs (4) must hold the pressure rollers (2) snugly against all layers of wire rope on the drum — from the first layer to the last layer.

2. If necessary, increase the tension of the springs (4) by tightening the eyebolts (5).

Pressure Roller (Drum 1)

See [Figure 5-31](#) for the following instructions.

Daily Maintenance

NOTE The springs (3) for the front drum pressure rollers (2) are not adjustable.

1. Watch the pressure rollers (2, View A) while paying out and hauling in the wire rope on the front drum (1).

The springs (3) must hold the pressure rollers (2) snugly against all layers of wire rope on the drum — from the first layer to the last layer.

2. Replace the springs (3) if they lose tension.



WARNING

Flying Object Hazard

The pressure roller springs for the front drum are pre-loaded.

Do not attempt to remove the front drum pressure roller assembly until the springs are compressed.

Parts will fly apart with violent force if this precaution is ignored.

Spring Replacement

1. Land the load on the drum and stop the engine.
2. Remove the compression rods (7) from storage (View A).
3. Assemble the compression rods (7) in the caging position (View B).
4. Tighten the hex nuts (7c), alternating from side to side, until the springs (3) are compressed and the pressure rollers (2) are pulled away from the wire rope on the drum.
5. Attach lifting slings from a hoist to the pressure roller assembly. It weighs 90 lb (41 kg).
6. Remove the screws (5, View A) and lift the pressure roller assembly away from the drum (1).
7. Loosen the hex nuts (7c), alternating from side to side, until the pre-load of springs (3) is fully released.
8. Disassemble the pressure roller assembly as needed to replace parts.
9. Reassemble the pressure roller assembly.
10. Assemble the compression rods (7) in the caging position (View B).
11. Tighten the hex nuts (7c), alternating from side to side, until the springs (3) are compressed.
12. Attach lifting slings from a hoist to the pressure roller assembly. It weighs 90 lb (41 kg).
13. Lift the pressure roller assembly into position at the mounting plates (4, View A).
14. Apply Loctite® 243 to the threads of the cap screws (5).
15. Install the cap screws (5) with flat washers to attach the pressure roller bracket (6) to the mounting plates (4).
If necessary, tighten the hex nuts (7c), alternating from side to side, to further compress the springs (3).
16. Torque cap screws (5) to 80 ft-lb (110 Nm).
17. Fully loosen hex nuts (7c), alternating from side to side.
18. Remove the compression rods (7) from the caging position (View B).
19. Store the compression rods (7, View A).

Location of Components at Boom Top Shown
Location of Components at Jib Tops is Similar

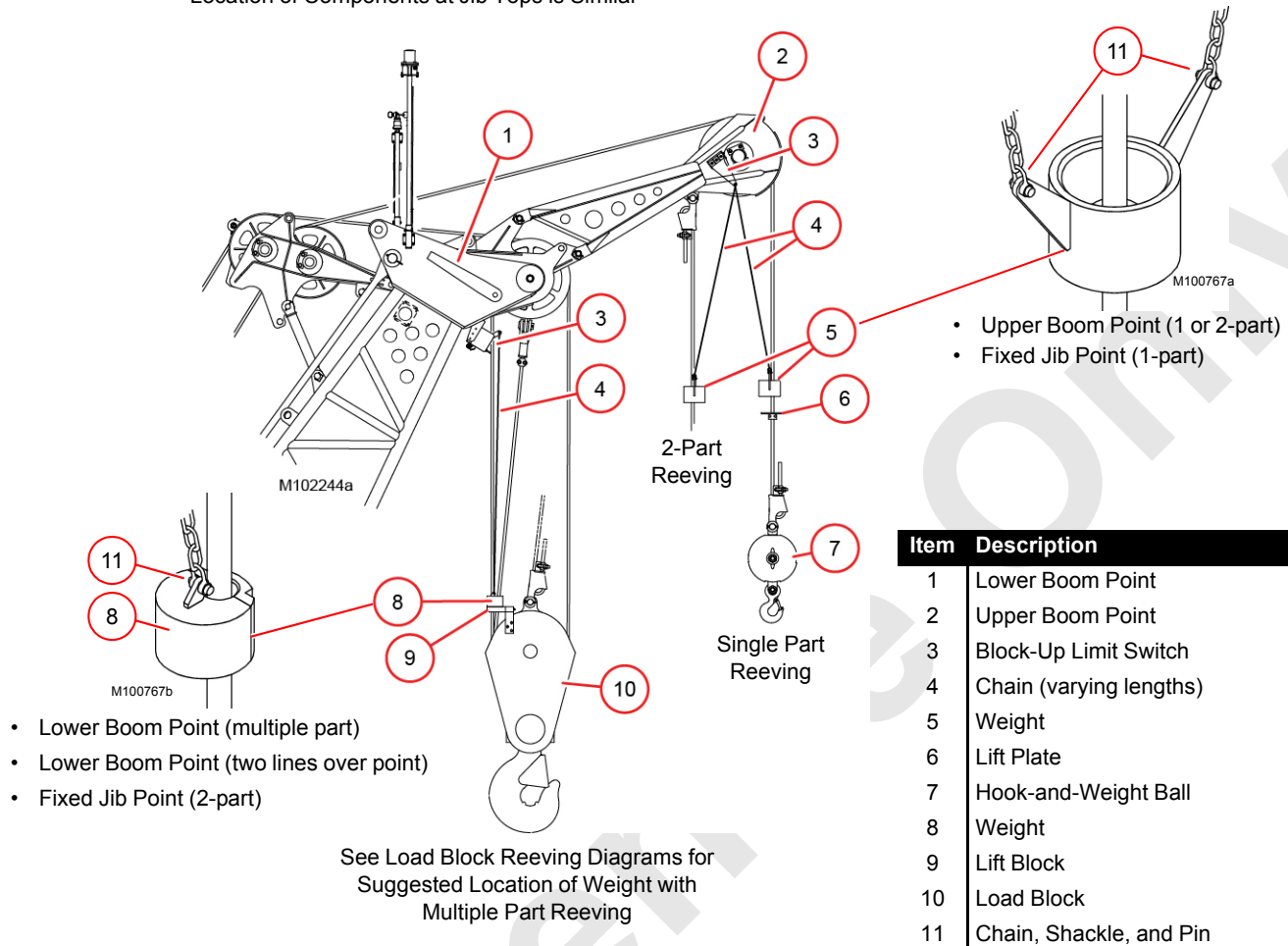

Figure 5-32. Block-Up Limit Components



WARNING

Two-Blocking Hazard

Two-blocking is the condition in which the load block or the hook-and-weight ball runs into the boom or jib sheaves.

Two-blocking can result in failure of the sheaves and wire rope, possibly causing the load to fall.

The operator shall determine the fastest line speed that allows the block-up limit to function properly and thereafter not exceed that line speed.

If the block or hook-and-weight ball approaches the boom sheaves too fast, the block-up limit may not prevent two-blocking.

BLOCK-UP LIMIT SWITCH

A block-up limit (also called anti-two-block device) is a two-blocking prevention device that stops the load drum from hoisting and the boom (or luffing jib) from lowering when a block or hook is too close to the sheave.

NOTE The block-up limit is a protective device designed only to assist the operator in preventing a two-blocking condition. Any other use is neither intended nor approved.

The block-up limit system consists of the following components (see [Figure 5-32](#)):

- A limit switch (3), wired for normally closed operation, fastened at the lower boom point (1) and the upper boom point (2).

- A weight (5 or 8) freely suspended by a chain (4) from each limit switch actuating lever (weight encircles load line as shown).
- A lift plate (6) fastened to the load line, or
A lift block (9) fastened to the load block.

For service of the block-up limit components in the luffing jib, see the MLC165 Luffing Jib Operator Manual supplied with the luffing jib.

Theory of Operation

See [Figure 5-32](#) and [Figure 5-33](#) for component identification.

For a complete wiring diagram of the system, see the Boom Wiring and Limits Drawing.

Normal conditions (Block-Up Limit Control Deactivated)—During normal operation, the weight overcomes spring force and rotates the actuating lever away from the limit switch lever. This allows the limit switch to close the hoist control handle electric circuits.

Block-Up Limit Control Activated—When the weight is lifted by the lift block or the lift plates, spring force rotates the actuating lever against the limit switch lever. This causes the corresponding limit switch to open the hoist control handle electric circuits.

Then the load drum and the boom/mast hoist pumps stroke to off. At the same time, the load drum and the boom hoist parking brakes apply to stop the load drum from hoisting and the boom from lowering.

Weekly Maintenance

See [Figure 5-32](#) for the following procedure.

CAUTION

Avoid Machinery Damage

If inspection reveals a problem with the block-up limit components, do not operate the crane until the block-up limit has been repaired to proper working order.

Inspect and test the block-up limits **weekly or every 40 hours of operation**, as follows:

1. Lower the boom (and the jib, if equipped) onto blocking at ground level.
2. Carefully inspect the following items:
 - a. Inspect each weight (5 and 8) for freedom of movement on the load line.
 - b. Inspect each weight, chain, shackle and connecting pin (11) for excessive or abnormal wear. Make sure the cotter pins for the shackles are installed and spread.

- c. Inspect the entire length of each electric cable for damage.
- d. Check that the electric cables are clear of all moving parts on the boom (and the jib, if equipped).
- e. Make sure that the cables are securely fastened to the boom (and the jib, if equipped) with nylon straps.
- f. Check that all electric cable connections are securely fastened.

3. Test the block-up limit devices for proper operation using **either** of the two following methods:

- Boom Lowered Method—

While the boom is lowered and with the engine running:

Manually lift one of the weights. Try to operate the drums. The corresponding load drum should not operate in the up direction and the boom hoist drum should not operate in the down direction.

Test each block-up limit device this way.

CAUTION

Avoid Sheave Damage

Use extreme care when testing the block-up limits when the boom is raised. If a block-up limit fails to stop the load, immediately stop the hoist.

- Boom Raised Method—

Slowly hoist one of the load blocks and the weight ball against the weight. When the chain goes slack, the corresponding load drum should stop and the boom hoist should not operate in the down direction.

Test each block-up limit device this way.

CAUTION

Avoid Sheave Damage

Do not lengthen or shorten the chains that hold the block limit weights. Proper chain length and weight is necessary for proper switch activation.

If replacement is needed, replace with the same length, size, and material specified in the Parts Manual.

| Item | Description |
|------|--------------------|
| 1 | Enclosure |
| 2 | Electric Cable |
| 3 | Spring |
| 4 | Eyebolt |
| 5 | Setscrew |
| 6 | Limit Switch Shaft |
| 7 | Limit Switch Lever |
| 8 | Actuating Lever |
| 9 | Enclosure Cover |
| 10 | Limit Switch |

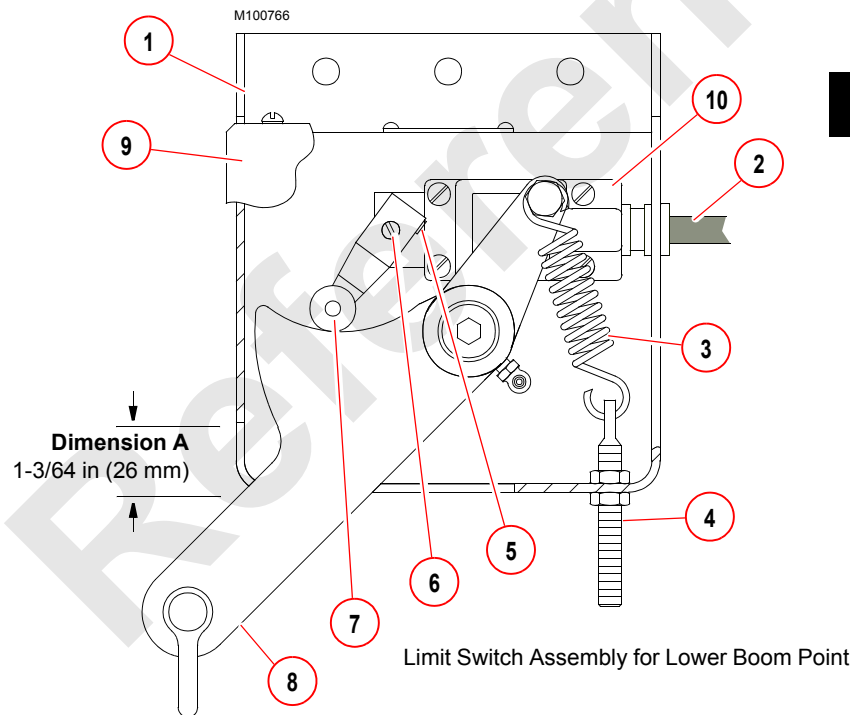
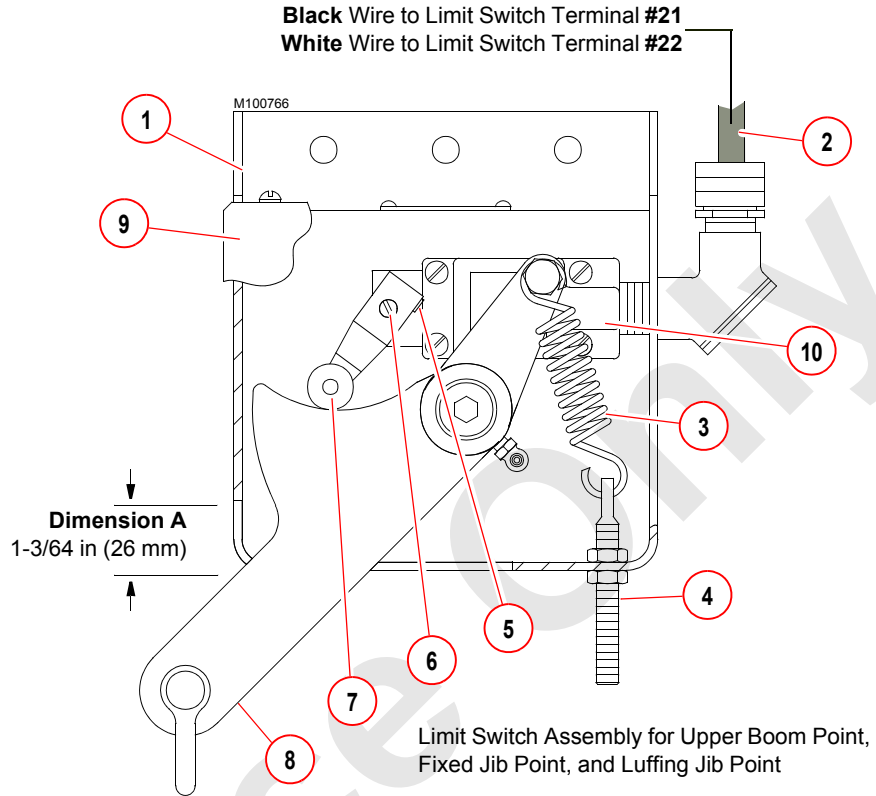

Limit Switch Wiring

| Wire Color | Switch Terminal | Function |
|------------|-----------------|---------------|
| Black | 13 | N/O |
| Green | 14 | 24 VDC Supply |
| White | 21 | N/C |
| Blue | 14-22 | Jumper |

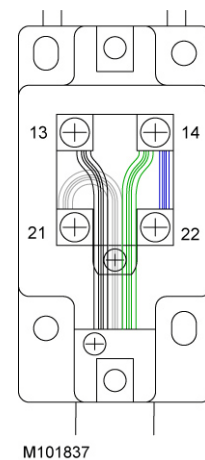

Figure 5-33. Block-up Limit Switch Assembly

Adjustment

See [Figure 5-33](#) for the following procedure.

Lower the boom and jib onto blocking at ground level and adjust each limit switch as follows:

1. Remove the cover (9) from the enclosure (1).
2. Adjust the tension of the spring (3) with the nuts on the eyebolt (4) so there is enough force to lift the weight of the chain and rotate the actuating lever (8) up when the weight is lifted.
3. Loosen the setscrew (5) in the limit switch lever (7) so the lever is free to rotate.
4. Manually lift the weight to allow the actuating lever (8) to rotate up.
5. Hold the actuating lever (8) at the Dimension A.
6. Hold the roller on the limit switch lever (7) against the actuating lever (8) while performing [step 7](#).
7. Turn the limit switch shaft (6) **CLOCKWISE** *only enough to “click” the limit switch open and hold.*
8. Securely tighten the setscrew (5) in the limit switch lever (7).
9. Test the limit switch for proper operation and repeat the adjustment steps until the limit switch operates properly.
10. Install the cover (9) on the bracket (1).

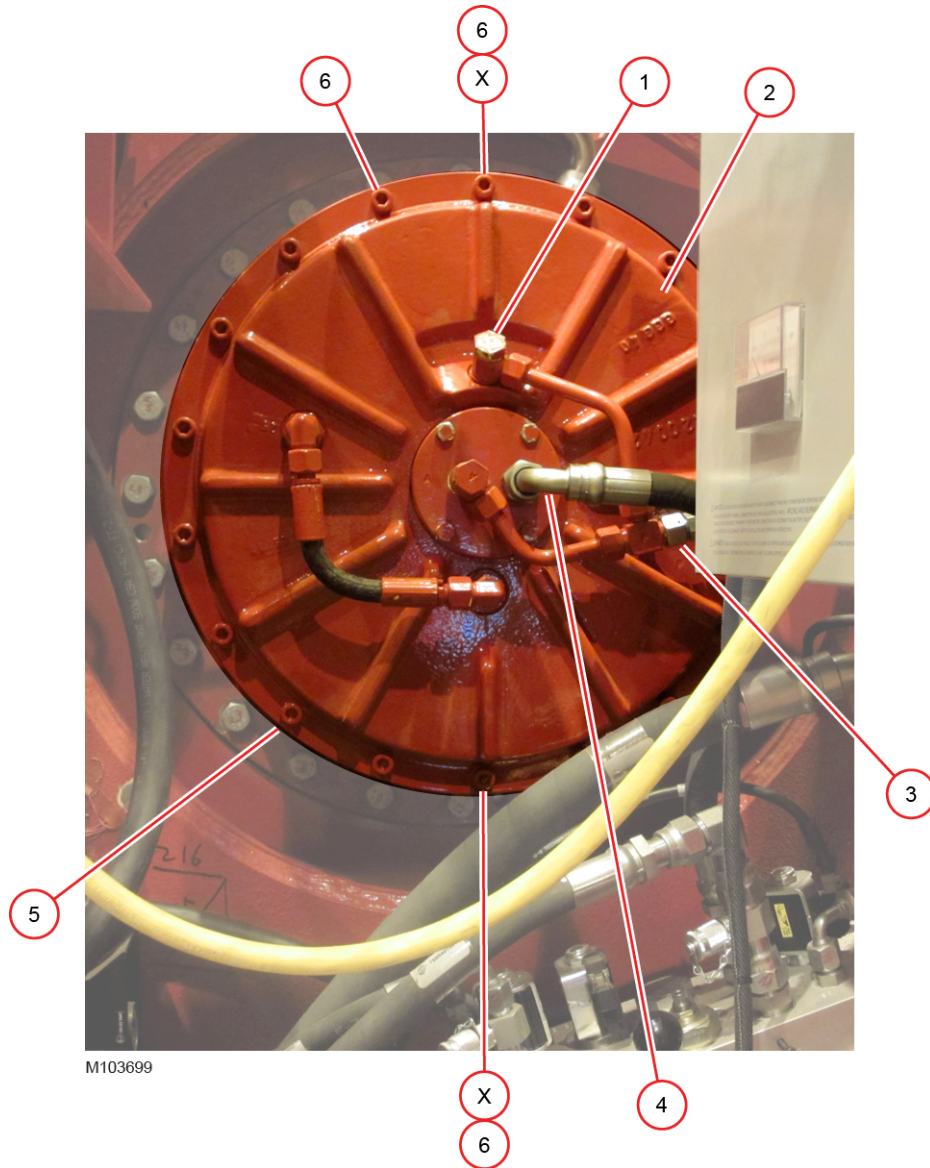

Right End of Either Load Drum in Right Side Enclosure

| Item | Description |
|------|--|
| 1 | Swivel Fitting in SUPPLY Port |
| 2 | Cover |
| 3 | Supply Hose |
| 4 | Case Drain Hose |
| 5 | Brake Housing |
| 6 | Bolt: 18 each M10 x 8,8 Threads x 35 mm long |

Figure 5-34. Free Fall Brake

FREE FALL BRAKE

Either or both load drums (front and rear) can be equipped with a free fall brake, [Figure 5-34](#), on the right end of the drum gearbox.

The free fall brakes must be serviced by factory trained personnel. For assistance, contact the Manitowoc Crane Care Lattice Team.



DANGER

Flying Object Hazard!

Brake springs are preloaded. Free fall brake assembly can fly apart with dangerous force.

To prevent death or serious injury, perform the following procedure to relieve the spring preload.

Removing Free Fall Brake Cover

1. Lower all loads to the ground and park the load drums.
2. Turn off the free fall mode for the drum being serviced. This will vent system pressure from the brake housing.
3. Stop the engine.

NOTE During the following steps, catch the hydraulic oil leakage in suitable container.

4. Disconnect the swivel fitting (1) from the supply port in the cover (2).

5. Disconnect the supply hose (3).
6. Disconnect the case drain hose (4).
7. Mark the cover (2) position with relation to the brake housing (5) so the cover can be reinstalled in the same position.
8. Remove two bolts (6), 180° apart — at locations marked **X** for example — from the cover (2).
9. Install two user furnished long bolts in place of the two standard bolts (6) removed in [step 8](#).

Long bolt specifications:

- M10 x 8,8 threads
- 200 mm long

10. Connect an owner supplied hydraulic hand pump to the supply port in the cover. The port is ISO 9974 with M16 x 1,5 threads.
11. Apply and hold 60 bar (870 psi) hydraulic pressure to the port.
12. Remove the remaining bolts (6) from the cover (2).
13. Slowly relieve the hydraulic pressure from the supply port with the hand pump.
14. The cover can now be removed. Use care. The springs will fall out as the cover is removed.

Installing Free Fall Brake Cover

Reverse the removal steps to reinstall the cover.

WIRE ROPE INSPECTION AND REPLACEMENT

The following information is from various wire rope manufacturers and includes inspection, replacement, and maintenance guidelines for wire rope as established by ANSI/ASME B30.5, federal regulations, and Manitowoc Cranes.

Wire Rope Lubrication

Refer to the Lubrication Guide in this manual for recommendations.

Maintain a Wire Rope Condition Report

Always keep on file a signed and dated periodic inspection report of the wire rope's condition. The report must cover all inspection points discussed in this section. The information in the reports can then be used to determine when a wire rope should be replaced.

After initial loading of a new rope, measure and record its diameter for comparison with future inspections. Measure the rope's diameter across the crowns of the strands so the true diameter is measured as shown in [Figure 5-36 on page 5-55](#).

Wire rope removed from service should be examined and a corresponding report kept. This information can be used to establish a relationship between visual inspection and the rope's actual internal condition at the time of its removal from service. See [Replacement Criteria on page 5-54](#) for inspection guidelines.

Required Inspection Intervals

The frequency of wire rope inspection should be:

- Daily (see [Daily Inspection on page 5-53](#))

and, **at minimum:**

- Yearly (see [Periodic Comprehensive Inspection on page 5-54](#))

Wire Rope Care and Replacement Guidelines

1. When replacing fixed-length wire rope assemblies (such as pendants) having permanently attached end fittings, use only pre-assembled lengths of wire rope as supplied from Manitowoc Cranes. Do not build lengths from individual components.
2. Replace an entire wire rope assembly. Do not attempt to rework damaged wire rope or wire rope ends.
3. Never electroplate wire rope assemblies.
4. Do not weld any wire rope assembly or component unless welding is recommended by the wire rope manufacturer.

Welding spatter must never be allowed to come in contact with the wire rope or wire rope ends. In addition, be sure that the wire rope is not an electrical path during other welding operations.
5. Wire ropes are manufactured from special steels. If heating a wire rope assembly is absolutely necessary for removal, the entire wire rope assembly must be discarded.
6. On systems equipped with two or more wire rope assemblies operating as a matched set, they must be replaced as an entire set.
7. Do not paint or coat wire ropes with any substance except approved lubricants.

Daily Inspection

Wire rope should be inspected in accordance with ANSI/ASME B30.5 and OSHA 29 CFR 1926.1413. A running record of the condition of each wire rope the wire rope should be noted in the equipment inspection log (see [Maintain a Wire Rope Condition Report on page 5-52](#)).

WARNING

Personal Injury Hazard

Prior to conducting an inspection of wire rope:

- Always lock out equipment power when removing or installing wire rope assemblies.
- Always use safety glasses for eye protection.
- Wear protective clothing, gloves, and safety shoes as appropriate.
- Use supports and clamps to prevent uncontrolled movement of wire rope, parts, and equipment.

See [Figure 5-35](#) for the following procedure.

1. Each work day, prior to crane work, visually inspect all rope that can reasonably be expected to be used that day. Check for obvious damage, including:
 - Rope defects such as shown in [Figure 5-35](#).
 - Loss of rope diameter (see [Reduction in Rope Diameter on page 5-54](#)).
 - Broken wires—Record the number, distribution and type of broken wires (see [Broken Rope Wires on page 5-55](#)).
 - Internal wear or broken wires for ropes operating on synthetic sheaves. Common indicators of internal deterioration include localized reduction in rope diameter, corrosion between the strands, localized lengthening of lay, wire displacement, or wire distortion.
 - End fitting wear/abrasion.
 - Minor or general corrosion.
 - Areas that deteriorate more rapidly, such as flange points, crossover points, and repetitive pickup points on drums.
 - Take special care to observe boom hoist ropes and rotation-resistant ropes for evidence of core failure or other deterioration—remove from service. Internal deterioration of rotation-resistant ropes may not be readily observable.

2. Throughout the day, observe wire rope during operation, particularly:
 - Pick-up Points—Sections of wire rope that are repeatedly stressed during each lift, such as those sections in contact with sheaves.
 - End Attachments—The point where a fitting is attached to the wire rope or the point where the wire rope is attached to the drum.
 - Abuse Points—The point where the wire rope is subjected to abnormal scuffing and scraping.

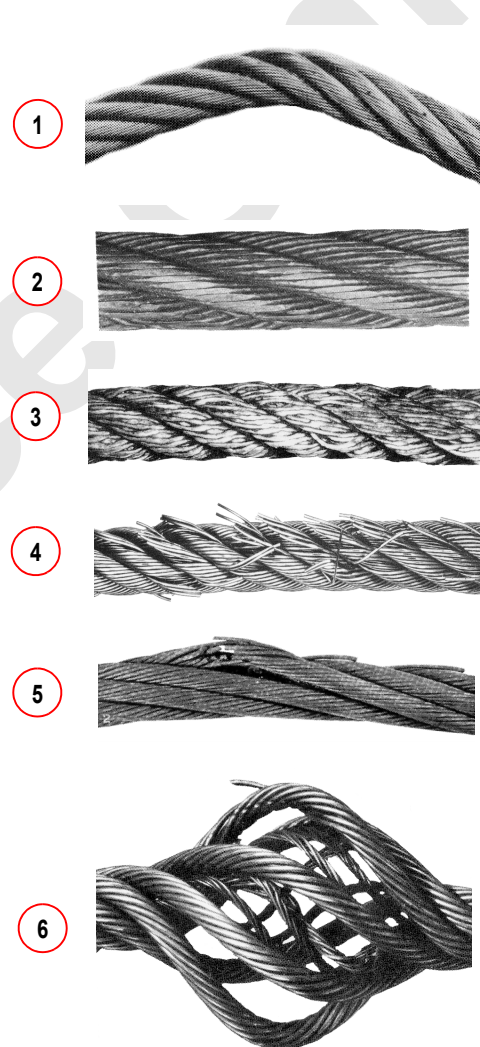

| Item | Description |
|------|------------------------------------|
| 1 | Dog-Leg or Kink |
| 2 | Drum Abrasion |
| 3 | Drum Crushing |
| 4 | Sheaves Too Small |
| 5 | Corrosion |
| 6 | Bird Cage (sudden release of load) |

Figure 5-35.

Periodic Comprehensive Inspection

The comprehensive inspection must be done by a qualified person. The inspection must include pulling all the rope off the drum and carefully inspecting the entire length.

The inspection must include:

- All points listed under [Daily Inspection on page 5-53](#).
- Inspection of rope diameter (see [Reduction in Rope Diameter on page 5-54](#)).
- Comprehensive examination for broken wires (see [Broken Rope Wires on page 5-55](#)).
- End connections: Check for broken wires or severely corroded, cracked, bent, worn, or improperly applied end connections.
- Areas subjected to rapid deterioration such as:
 - Sections in contact with saddles, equalizer sheaves, or other sheaves where wire rope travel is limited.
 - Sections of wire rope at or near terminal ends where corroded or broken wires may protrude.
- Inspection of boom sheaves, hook block sheaves, gantry/mast sheaves, boom extension/jib sheaves, jib strut sheaves, and hoist drums for wear.

NOTE: Damaged sheaves or hoist drums can accelerate wear and cause rapid deterioration of the wire rope.

Any damage of the wire rope found must be recorded and a determination made as to whether to continued use of the rope is safe. Refer to [Replacement Criteria on page 5-54](#).

 **DANGER**
Falling Load Hazard

- As a wire rope approaches the end of its useful life, inspections should be performed more frequently.
- All wire rope will eventually deteriorate to a point where it is no longer usable.
- A comprehensive inspection of each wire rope must be performed at least once a year.

Determining Frequency of Inspection

Intervals for comprehensive inspections may vary from machine to machine. The inspection interval must be determined by a qualified person and be based on such factors as:

- Expected rope life as determined by experience on the particular installation or similar installations.

- Size, nature, and frequency of lifts.
- Rope maintenance practices.
- Severity of environment, such as:
 - Variation in temperature.
 - Continuous excessive moisture levels.
 - Exposure to corrosive chemicals or vapors.
 - Subjecting the wire rope to abrasive material.
 - Powerline contact.
- Exposure to abuse and shock loads, such as:
 - High-velocity movement, such as hoisting or swinging of a load followed by abrupt stops.
 - Suspending loads while traveling over irregular surfaces such as railroad tracks, potholes, and rough terrain.
 - Moving a load that is beyond the rated capacity of the lifting mechanism (overloading).

NOTE: Inspection intervals may also be pre-determined by state and local regulatory agencies.

Replacement Criteria

The decision as to when a wire rope should be replaced is the responsibility of the qualified person who is appointed to review rope inspection records and evaluate rope condition.

The following are indications that the rope needs to be replaced:

- Reduction in rope diameter and excessive broken wires. See [Reduction in Rope Diameter on page 5-54](#) and [Broken Rope Wires on page 5-55](#).
- Wear of one-third the original diameter of outside individual wires.
- Kinking, crushing, birdcaging, or any other damage resulting in distortion of the rope structure.
- Evidence of any heat damage from any cause.
- Severe corrosion as evidenced by pitting.
- Independent wire rope core (IWRC) or strand core protrusion between outer strands.
- Obvious damage exists from any heat source to include—but not limited to—welding, power line strike, or lightning.

Reduction in Rope Diameter

A reduction in rope diameter is often the first outward sign that the rope core is damaged. Reduction in rope diameter can be caused by loss of core support, internal or external corrosion, or wear of the outside wires.

New Wire Rope—After initial loading, measure and record the diameter of any new wire rope for comparison to future inspections. See [Maintain a Wire Rope Condition Report on page 5-52](#).

The wire rope shall be taken out of service when the reduction from its nominal diameter is more than 5 percent.

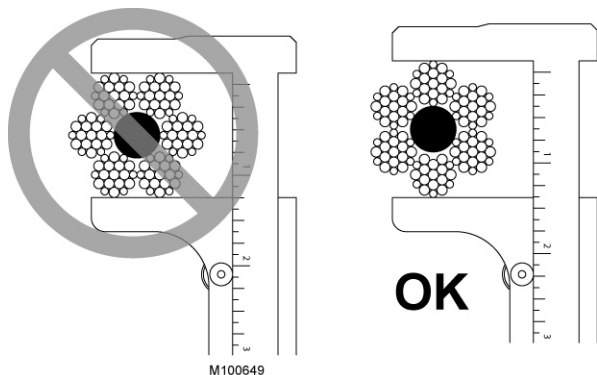

Figure 5-36.

Broken Rope Wires

When conducting the Periodic Comprehensive Inspection, thoroughly clean the wire rope so breaks can be seen. Relax the rope, move it off “pick-up points,” and flex it as much as possible. Use a sharp awl to pick and probe between wires and strands, lifting any wire which appears loose or moves excessively. **Do not open strands of rotation-resistant rope.**

Wire breaks are typically at the crown of the strands—the area that contacts the sheave or drum when a load is picked up. Breaks at the crown will appear as small gaps in a wire. In comparison, when wires in the valley of a strand break, the broken ends will rise up and are easier to notice.

NOTE: The [Daily Inspection on page 5-53](#) does not require that the rope be cleaned or probed.

The wire rope shall be taken out of service when it has the following number of broken wires:

See [Figure 5-38 on page 5-56](#) for an explanation of lay length.

- Running Ropes—six randomly broken wires in one lay length or three broken wires in one strand in one lay length.
- Standing Ropes (Pendants)—more than two broken wires in one lay length in sections beyond the end

attachment, or more than one broken wire at the end attachment (see [Figure 5-37](#)).

- Rotation-resistant Rope—two randomly distributed broken wires in six rope diameters or four randomly distributed broken wires in 30 rope diameters.
- All Ropes—one outer wire broken at the point of contact with the core and protrudes or loops out of the rope structure—additional inspection is required.
- End Attachments ([Figure 5-37](#))—when more than one broken wire appears at the attachment, replace the rope or cut off the affected area and reattach the fitting.

NOTE: For galvanized bridle strand wire rope pendants—United States Steel states “Replacement criteria for galvanized strand boom suspension pendants are 25 percent of the outer wires fractured, or 10 percent of the total numbers, whichever comes first.”

! WARNING
Falling Load Hazard
 Replace wire rope when more than one broken wire appears at point marked by arrow.

| Item | Description |
|------|---------------------|
| 1 | Swagged Socket |
| 2 | Wedge Socket |
| 3 | Poured Zinc Socket |
| 4 | Hand-spliced Socket |
| 5 | Button Socket |

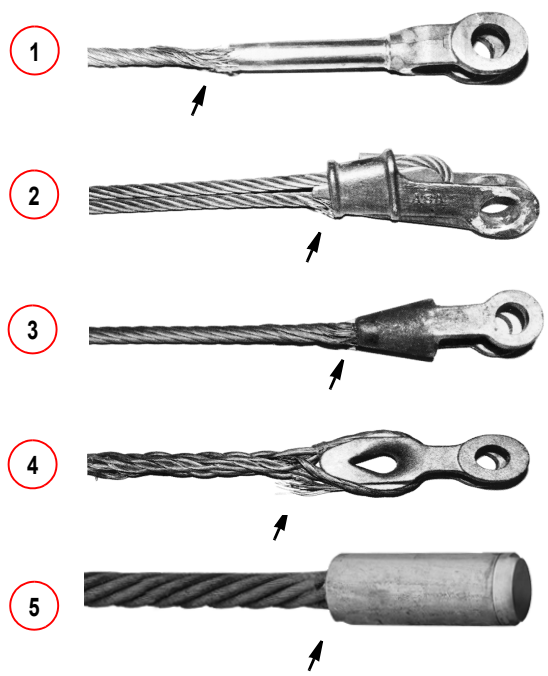

M100654a-e

Figure 5-37.

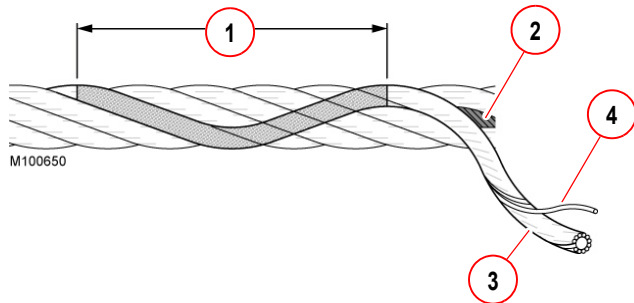

| Item | Description |
|------|---|
| 1 | Lay Length: distance in which one strand makes one complete revolution around core. |
| 2 | Core |
| 3 | Strand |
| 4 | Wire |

Figure 5-38.

Rope That Has Been Idle a Month or More

Wire rope must be given a complete inspection if it has been idle for a month or more. The inspection must be performed by a qualified inspector looking for the damage identified under both **Daily** and **Periodic Comprehensive Inspection**.

NOTE: Wire rope may be purchased through the Manitowoc Crane Care Lattice Team.

! DANGER

Falling Load Hazard

Replacement wire rope can break if it does not meet Manitowoc specifications given in the following publications supplied with your crane:

- Wire Rope Specifications Chart located in Capacity Chart Manual (for load lines).
- Boom or jib assembly drawings located in MLC165-1 Operator Manual (for boom or luffing hoist).
- Mast assembly drawing located in the MLC165-1 Parts Manual.

Distributing Wire Rope Wear

Wire rope wear at the “critical wear points” can be reduced and the life of the wire rope extended by moving the rope at regular intervals so different sections of rope are subjected to the wear points. This practice can also help correct spooling problems and rope vibration.

To move the wire rope, cut off a piece of wire rope at the worn end and refasten. The piece cut off should be long enough to move wire rope at least one full drum wrap.

If the wire rope is too short to allow cutting off a piece of it, reverse the rope end for end and refasten it.

SHEAVE, ROLLER, AND DRUM INSPECTION (WEEKLY)

Perform the following inspections **weekly**.

1. Check the drum clutches and brakes for proper adjustment.
2. Check all sheaves, rollers, and drums for the following conditions:
 - Unusual noises.
 - Freedom of movement—must turn freely by hand. Wire rope may have to be loosened to perform this inspection.
 - Wobble—must turn true with very little side-to-side or up-and-down play.
 - Signs of rust (indicating that water may have entered bearing).
 - Grease leaks (indicating a faulty seal or water in grease).

The above problems indicate bearing damage. If found, the corresponding sheave, roller, or drum should be disassembled for further inspection. New bearings should be installed.

For sheaves not equipped with grease fittings, be sure to pack new bearings with grease at assembly.

3. For steel sheaves, check depth, width, and contour of each sheave using a groove gauge as shown in [Figure 5-39](#). Replace sheaves that have over or under size grooves.
4. Replace grooved drums that allow one wrap of wire rope to contact next wrap as rope spools onto drum.
5. Inspect sheaves to verify they **do not** contact another sheave or structural plate work. There should be uniform clearance between sheaves in a cluster. Repair or replace worn or damaged sheaves.
6. Remachine or replace steel sheaves, drums, or rollers that have been corrugated by the wire rope's print as shown in [Figure 5-40](#).
7. Inspect nylon sheaves for excessive tread diameter wear at locations **E** in [Figure 5-41 on page 5-58](#). Measure at three places to check for uneven wear.

Wear must not exceed the limits given in the table. **Replace worn or damaged sheaves.**

Observe groove to see if contour of gauge matches contour at bottom of sheave groove.

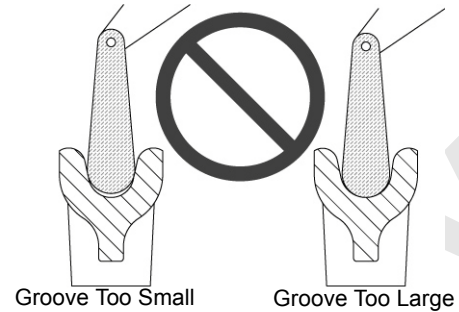

Proper fitting sheave groove should support wire rope or 135–150° of rope circumference.

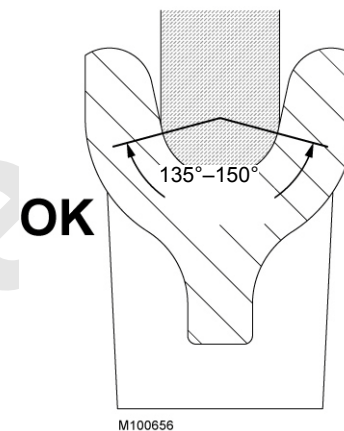

Figure 5-39.

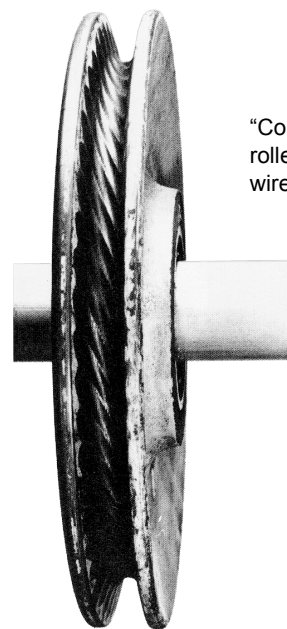

Figure 5-40.

8. Inspect nylon sheaves to verify they have not separated and “walked off” steel inserts or bearings as shown in [Figure 5-41](#). Maximum sideways displacement is 1/8 in (3 mm). **Replace worn or damaged sheaves.**

NOTE: Depending on the type of wire rope used, it is normal for nylon sheaves to show the wire rope print. **Do not re-machine nylon sheaves.**

NOTE: Nylon sheaves cannot be accurately inspected using conventional methods such as sheave gauges.

Due to the characteristics of nylon sheaves, the nylon material will actually move to better support the wire rope as the sheave wears normally.

Nylon sheave properties will be degraded in temperatures above 140° F (60° C).

| Item | Description |
|------|---|
| 1 | Nylon Sheave |
| 2 | Improper Snap Ring Engagement |
| 3 | Steel Insert of Bearing |
| 4 | 1/8 in (3 mm) Maximum Sideways Displacement |

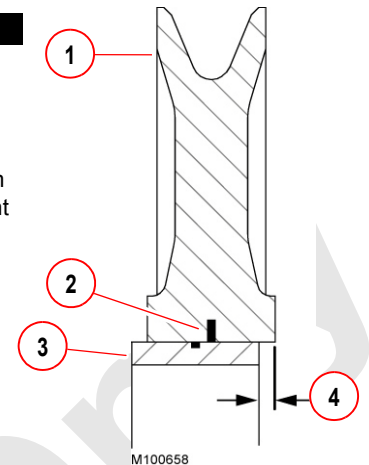

Figure 5-41.

9. Make sure sheaves, drums, and rollers are properly lubricated according to the instructions in the lubrication guide provided with the crane (see Section 9 in this manual).

NOTE: Many current production sheaves are not equipped with grease fittings, but are packed with grease at assembly. Repack the bearings of these sheaves with CraneLUBE EP #2 grease when the sheaves are overhauled.

Due to application and design variations, it is not possible to give specific grease repacking intervals or the life expectancy of components.

NOTE: For some sheaves, the seals are an integral part of the bearing. Therefore, if a seal is damaged during repacking, the complete bearing may have to be replaced.

E = Replacement dimension
 E = B - 3/16 in (5 mm) (maximum)
 If tread print exists in root of sheave groove, measure to maximum tread diameter.

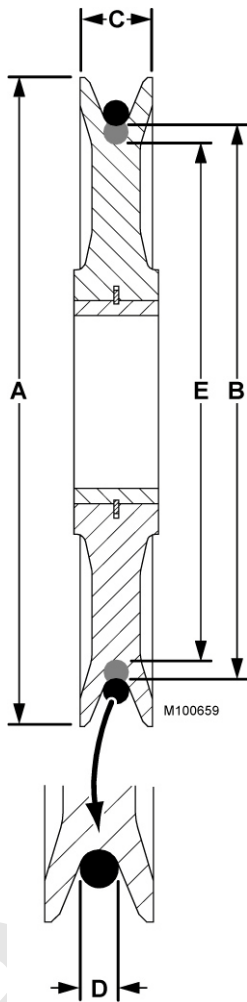

| PLASTIC SHEAVE DATA | | | | | | | | |
|----------------------------|-----------------------|-------|---------------------|-------|------------|------|--------------------|----|
| Sheave Part No. | A Outside Diameter | | B Tread Diameter | | C Width | | D Rope Diameter | |
| | inch | mm | inch | mm | inch | mm | inch | mm |
| 912738 631056 | 13.19 | 335.0 | 11.42 | 290.1 | 1.77 | 45.0 | 5/8 | 16 |
| 631054 | 13.19 | 335.0 | 11.42 | 290.1 | 1.77 | 45.0 | 7/8 | 22 |
| 631065 | 16.00 | 406.4 | 13.37 | 339.6 | 2.17 | 55.1 | 9/16 | 14 |
| 631071 | 16.00 | 406.4 | 13.88 | 352.6 | 2.17 | 55.1 | 5/8 | 16 |
| 631526 | 19.25 | 489.0 | 16.63 | 422.4 | 1.94 | 50.8 | 7/8 | 22 |
| 631527 | 19.25 | 489.0 | 16.63 | 422.4 | 1.94 | 50.8 | 5/8 | 16 |
| 631055 | 19.69 | 500.1 | 17.60 | 447.0 | 1.85 | 47.0 | 7/8 | 22 |
| 631067 | 19.69 | 500.1 | 17.75 | 450.9 | 1.97 | 50.0 | 3/4 | 19 |
| 631529 | 20.00 | 508.0 | 17.00 | 431.8 | 3.00 | 76.2 | 1 | 25 |
| 631519 631520 | 23.00 | 584.2 | 20.13 | 511.0 | 2.25 | 57.2 | 7/8 | 22 |
| 631084 A00083 | 23.00 | 584.2 | 20.13 | 511.0 | 2.50 | 63.5 | 7/8 | 22 |
| 631102 | 23.00 | 584.2 | 20.13 | 511.0 | 2.50 | 63.5 | 1 | 25 |
| 631082 631103 A00051 | 27.00 | 685.8 | 23.00 | 584.2 | 3.00 | 76.2 | 1 | 25 |
| 631096 A00050 | 27.00 | 685.8 | 23.00 | 584.2 | 3.00 | 76.2 | 1.18 | 28 |
| 631100 | 30.00 | 762.0 | 27.00 | 685.8 | 3.00 | 76.2 | 1-1/8 | 29 |

5

Figure 5-42.

LOAD BLOCK AND HOOK-AND-WEIGHT BALL INSPECTION

WARNING Falling Load Hazard

To prevent load from dropping due to structural failure of load block or hook-and-weight ball:

- Only use a load block or a hook-and-weight ball which has a capacity equal to or greater than load to be handled.
- Do not remove or deface nameplate attached to load blocks and hook-and-weight balls.
- See Section 4 of the MLC165-1 Operator Manual for recommended sling angles and capacity restrictions when load block has duplex or quadruplex hook.



| Item | Description |
|------|--|
| 1 | Working Load Limit (ton (US and metric)) |
| 2 | Wire Rope Diameter (in and mm) |
| 3 | Block Weight (lb and kg) |
| 4 | Block Serial Number |
| 5 | Block Part Number (OEM and Maniowoc) |
| 6 | Design Factor |

Figure 5-43.

The operating condition of the load block and the hook-and-weight ball can change daily with use. Therefore, they must be inspected daily (at start of each shift) and observed during operation for any defects which could affect their safe operation. Correct all defects before using the load block or the hook-and-weight ball.

Daily inspection and maintenance will include the following points (see [Figure 5-44](#) and [Figure 5-45](#)):

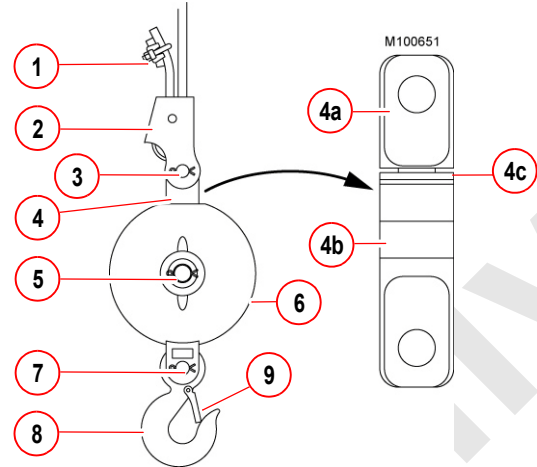

| Item | Description | Item | Description |
|------|------------------|------|----------------|
| 1 | Dead-End Clip | 4c | Check Gap Here |
| 2 | Socket and Wedge | 5 | Bolt or Pin |
| 3 | Bolt or Pin | 6 | Weight Ball |
| 4 | Swivel | 7 | Bolt or Pin |
| 4a | Swivel Shank | 8 | Hook |
| 4b | Swivel Barrel | 9 | Latch |

Figure 5-44.

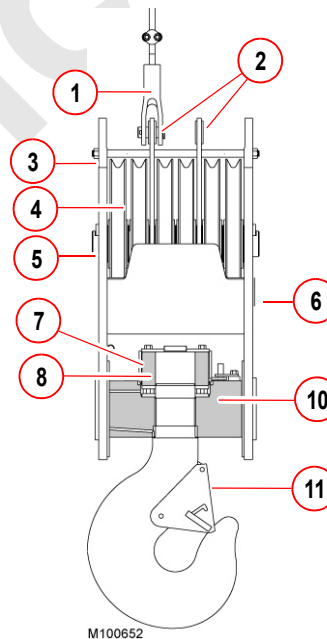

| Item | Description |
|------|------------------|
| 1 | Socket and Wedge |
| 2 | Center Plates |
| 3 | Tie Bolt |
| 4 | Sheaves |
| 5 | Sheave Shaft |
| 6 | Name Plate |
| 7 | Locking Cap |
| 8 | Hook Nut |
| 9 | Trunnion |
| 10 | Thrust Bearing |
| 11 | Latch |
| 12 | Hook |

Figure 5-45.

1. Clean the load block or the hook-and-weight ball.
2. Lubricate the sheaves (if fittings provided), the hook trunnion, the hook swivel, and any other part equipped with a grease fitting at the intervals specified in the "Lubrication Guide."
3. Tighten loose tie-bolts, cap screws, and set screws. Check that all cotter keys are installed and opened.

4. Check the sheaves for uneven wear in the grooves and on the flanges. Check for loose or wobbly sheaves. These conditions indicate faulty bearings or bushings.
5. Check the fit of the wire rope in the groove of each sheave. An oversize wire rope can crack the lip of the sheave flange causing rapid wear of the wire rope and sheave. The groove must be larger than the wire rope, and the groove must be free of rough edges and burrs.
6. Check that the hook, the trunnion, and the swivel rotate freely without excessive play. Faulty operation indicates faulty bushings or bearings or inadequate lubrication.
7. Check the swivel of the hook-and-weight ball for the following conditions:
 - Overloading: Spin the swivel by hand. If the motion is rough or has a ratchet-like effect, the swivel bearings are damaged.
 - Side loading: The swivel will turn freely in one spot and lock-up in another. This condition can also be checked by checking the gap (4c, [Figure 5-44 on page 5-60](#)) between the barrel and shank (swivel must be removed from weight ball to check). If the gap is wide on one side and closed on the other side, damage is present.

NOTE: The gap between the barrel and the shank is normally 0.02 in (0,5 mm) to 0.05 in (1,3 mm). If the gap increases, swivel-bearing failure is indicated.

8. Check the load block for signs of overloading: spread side plates, elongated holes, bent or elongated tie-bolts, and cracks.
9. Check all welds for defects and cracks.
10. Check the wire rope for wear and broken wires at the point the wire rope enters the dead-end socket. Check the socket for cracks. Tighten the wire-rope clips at the dead end of the wire rope.
11. Check that each hook has a latch and that the hook latch operates properly. **The latch must not be wired open or removed.**
12. Check each hook and shackle at least yearly for cracks using a dye penetrant test, MAG particle test, ultrasonic test, or by X-ray.



WARNING Falling Load Hazard

To prevent load from dropping due to hook or shackle failure, do not attempt to repair cracks in hooks and shackles by welding. Do not weld on any load bearing component unless proper welding methods are used (contact the Manitowoc Crane Care Lattice Team for material and welding specifications).



WARNING Falling Load Hazard

To prevent load from dropping, hook latch must retain slings or other rigging in hook under slack conditions.

Hook latch is not intended as anti-fouling device, and caution must be taken to prevent hook latch from supporting any part of load.

Slings or other rigging must be seated in hook when handling load. They must never be in position to foul hook latch.

13. Inspect each hook and shackle for damage as shown in [Figure 5-46](#).
14. See the ASME B30-10 Standard for specific hook replacement guidelines. The standards are available as follows:
 - **Mail**— ASME, 22 Law Drive, Fairfield, New Jersey, 07004-2900
 - **Toll free phone**— US & Canada 800-843-2763, Mexico 95-800-843-2763, Universal 973-882-1167
 - **Fax**— 973-882-1717 or 973-882-515
 - **E-mail**— infocentral@asme.org
15. Contact the supplier of your hooks, shackles, blocks, and other rigging for repair instructions.

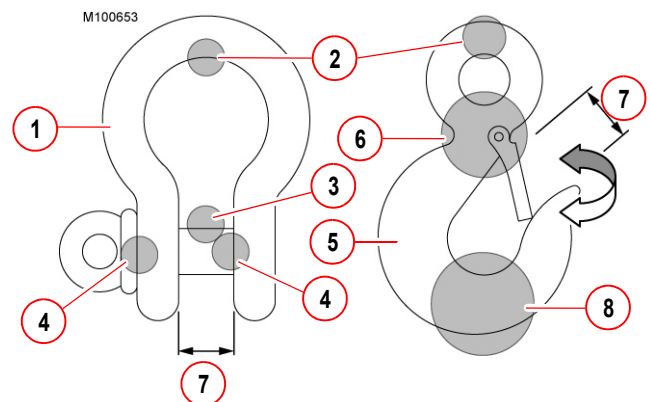

| Item | Description |
|------|---------------------------------|
| 1 | Shackle |
| 2 | Check for Wear and Deformation |
| 3 | Check for Wear and Straightness |
| 4 | Check that Pin is Always Seated |
| 5 | Hook |
| 6 | Check that Hook is Not Twisted |
| 7 | Check for Cracks and Twisting |
| 8 | Check for Wear and Cracks |

Figure 5-46.

THIS PAGE INTENTIONALLY LEFT BLANK

SECTION 6 SWING SYSTEM

TABLE OF CONTENTS

| | |
|---|-----|
| Swing System Overview | 6-1 |
| Swing Brake | 6-2 |
| Swing Brake Operation - Park Switch Control | 6-2 |
| Swing Brake Operation - Momentary Swing Brake Control | 6-2 |
| Swing Handle Command | 6-3 |
| Swing Pump Control | 6-3 |
| Swinging Left | 6-3 |
| Swinging Right | 6-3 |
| Coasting | 6-3 |
| Swing System Pressure Feedback | 6-3 |
| Swing Alarms | 6-3 |
| Manual Release of Swing Brake | 6-5 |
| Swing Gearbox | 6-6 |
| Gear Oil Specifications | 6-6 |
| Oil Analysis | 6-6 |
| Periodic Maintenance | 6-6 |
| Daily | 6-6 |
| Initial Operation | 6-6 |
| Every 40 Hours or Weekly | 6-6 |
| Every 6 Months or 1,000 Hours | 6-6 |
| Quick-Drain Valve | 6-7 |
| Oil Change Procedure | 6-7 |

Reference Only

THIS PAGE INTENTIONALLY LEFT BLANK

SECTION 6 SWING SYSTEM

SWING SYSTEM OVERVIEW

The swing motor and pump are isolated from the main open hydraulic system. It's a closed system in which an electrically controlled variable hydraulic pump drives a fixed hydraulic motor. Swing motor speed is proportional to the output flow volume of the swing pump. The swing motor drives a

planetary drive with a pinion gear output which drives the ring gear of the rotating bed to achieve rotation.

Swing speed and swing torque can be selected for the type of work being performed using the Function Mode screen (see the MLC165-1 Main Display Operation manual).

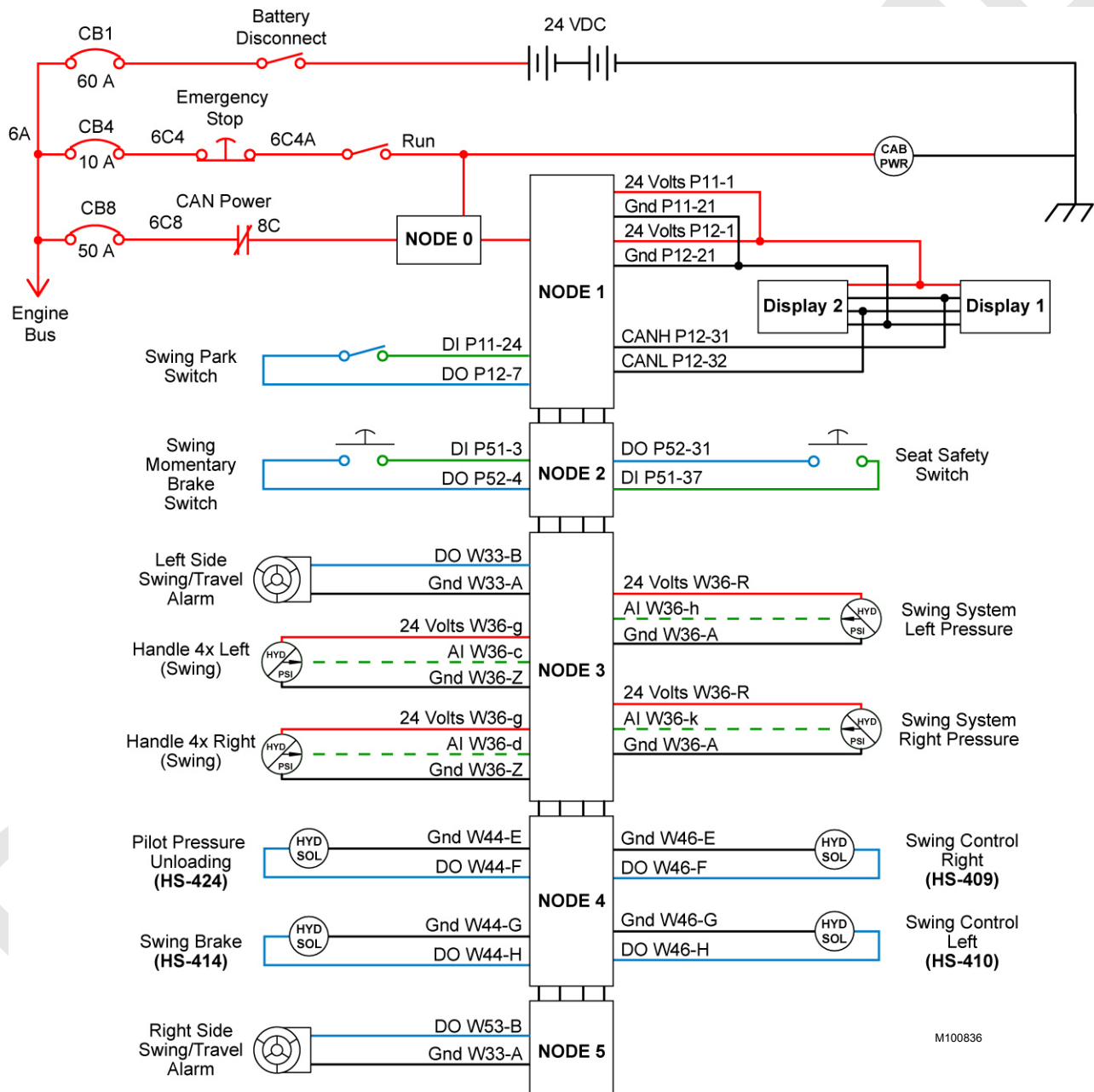
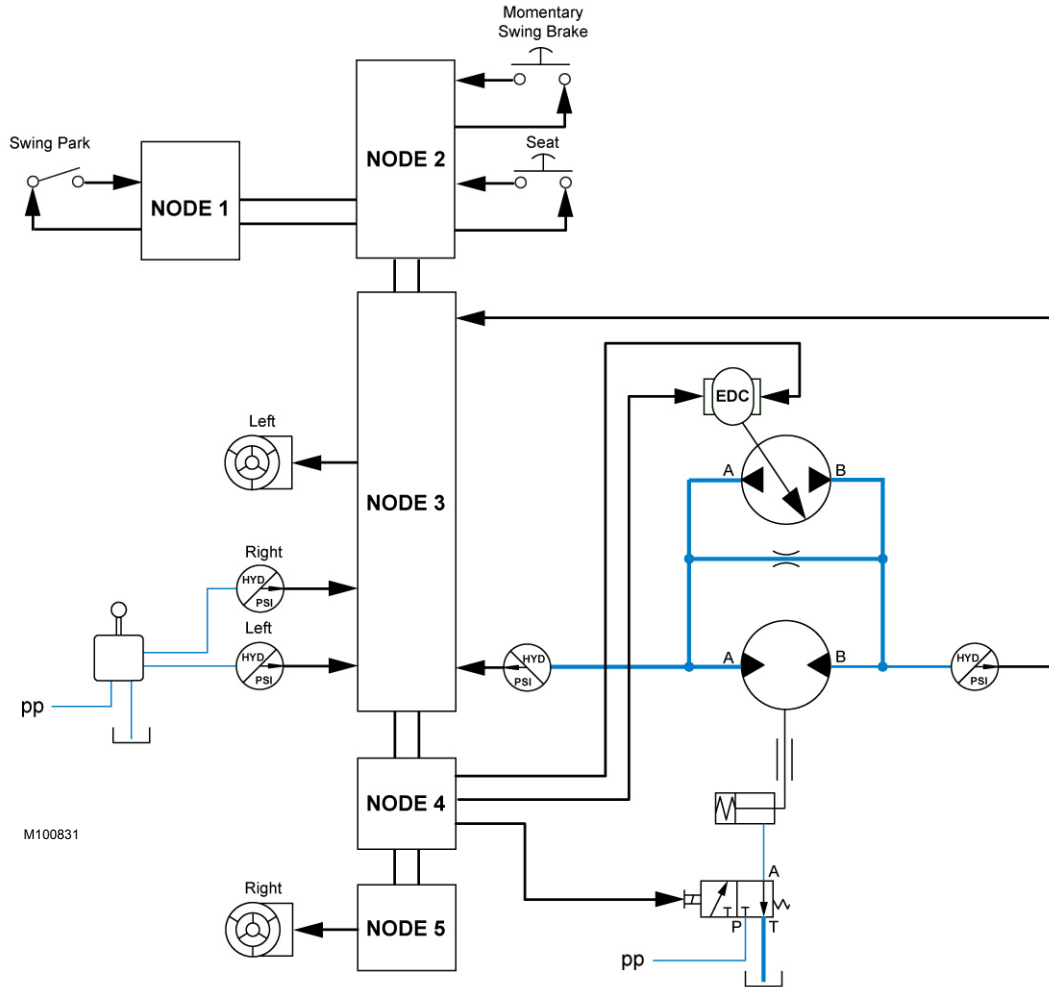

Figure 6-1. Swing System Electrical Diagram



M100831

Figure 6-2.

Swing Brake

The swing planetary drive has a spring-applied, hydraulically released brake at the input of the planetary drive after the motor. The swing brake has to be actively released by the control system. If brake hydraulic pressure or electric control is lost, the swing brake applies by spring force.

The main pump contains a charge pump which sources flow to the swing brake control valve. The brake pressure must be above 392 psi (27 bar) to fully release the brake. If the pressure is below this, the brake could become partially applied and damage the swing system.

Swing Brake Operation - Park Switch Control

Node 1 sends a 24Vdc output to the swing park switch. The swing park switch is closed in the OFF- PARK position, so node 1 reads back a 24Vdc signal from the switch. Node 4 sends a 24Vdc output to the swing brake valve solenoid, energizing it. This causes the swing valve to shift position, porting fluid to the brake cylinder, and releasing the brake.

When the swing brake switch is moved to the ON- PARK position, the swing park switch is open, sending a 0Vdc signal back to node 1. Node 4 controller sends a 0Vdc output voltage to the swing brake valve solenoid, de-energizing it. The swing brake valve returns to the normal position, porting fluid back to tank and the swing brake applies.

Swing Brake Operation - Momentary Swing Brake Control

Node 2 sends a 24Vdc output to the momentary swing park switch. The switch is normally open, sending a 0Vdc signal back to node 2. Node 4 sends a 24Vdc output to the swing brake valve solenoid, energizing it. This causes the swing valve to shift position, porting fluid to the brake cylinder, and releasing the brake.

When the momentary swing brake switch is closed, node 2 reads back a 24Vdc signal from the switch. Node 4 sends a 0Vdc output voltage to the swing brake valve solenoid, de-energizing it. Spring pressure within the spring brake applies the brake.

Swing Handle Command

The swing control system receives operator commands via a proportional hydraulic control handle. Left or right control handle movement ports pilot pressure to the corresponding pressure transducer. The pressure transducer sends a proportional 1Vdc to 3Vdc output signal to Node 3, which reads it as a command signal of swing speed.

Swing Pump Control

The swing pump is driven by the engine. Pump flow is both directional and variable, determined by position and stroke of a proportional solenoid valve in the electronic displacement control (EDC). Node 4 sends a 1.6 to 8.8Vdc PWM output signal to the EDC, with the current control range starting at 200mA and ending at 600mA. Node 4 ramps up the PWM duty cycle to meet the speed commanded at the control handle. As current increases, more fluid is ported to the swashplate servo pistons, increasing the swashplate angle. As the swashplate angle increases, so does the piston stroke within the pump, increasing pump output volume.

Swinging Left

When swinging left, node 4 sends a PWM signal to proportional solenoid B in the swing pump EDC, energizing it. The pump flows fluid port B to motor port B, and moving the operator cab to the left. Return fluid from motor port A flows to pump port A, completing the closed-loop circuit.

Swinging Right

When swinging right, node 4 sends a PWM signal to proportional solenoid A in the swing pump EDC, energizing it. The pump flows fluid port A to motor port A, and moving the operator cab to the right. Return fluid from motor port B flows to pump port B, completing the closed-loop circuit.

Coasting

When the swing control handle is moved back to the neutral position, Node 4 ramps down the PWM signal to the energized A or B EDC solenoid, allowing the springs to center the spool, moving the pump swashplate to center position, and ceasing swing drive.

The rotating bed is free to coast via an orifice in parallel with the motor and pump if the swing control handle is in neutral position and the swing brake is released.

Swing System Pressure Feedback

Pressure transducers at the A and B sides of the motor provide feedback for the control algorithm.

Swing Alarms

The swing alarms are activated anytime the EDC solenoid valve is being driven.

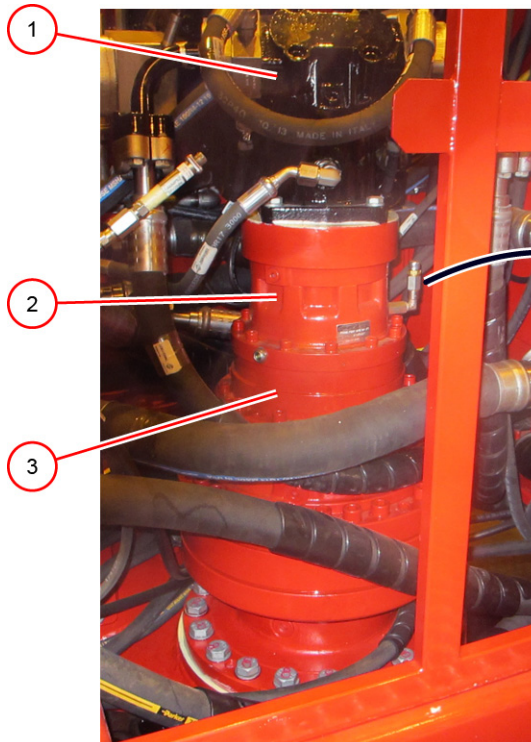

| Item | Description |
|------|---------------------------------|
| 1 | Swing Motor |
| 2 | Swing Brake |
| 3 | Swing Gearbox |
| 4 | Brake Release Hose |
| 5 | Brake Release Fitting (04 ORFS) |

M101866

Figure 6-3. Swing Drive

MANUAL RELEASE OF SWING BRAKE

When removing or installing the swing drive, the swing brake must be released to allow alignment of the pinion gear and the rotating bed ring gear.



WARNING

Unexpected Crane Movement

When the swing brake is released, the crane can suddenly swing. Before releasing the swing brake, secure the crane by lowering the boom onto blocking at ground level to prevent sudden uncontrolled swinging.

The swing brake manual release procedure is for servicing purposes only. Do not operate the crane unless the swing brake is fully operational.

NOTE A hydraulic hand pump with a pressure gauge is needed to manually release the swing brake.

See [Figure 6-3](#) for the following procedure.

1. At the brake (2) disconnect the brake release hose (4) from the brake release fitting (5).
2. Connect the hand pump hose to the brake release fitting (5).

CAUTIONS

Avoid damage to parts

Do not exceed 392 psi (27 bar) when releasing the swing brake with the hand pump.

3. Using the hand pump, pressurize the brake to 392 psi (27 bar).
The swing drive can now be removed.
4. To reapply the brake, relieve the pressure from the hand pump.
5. Disconnect the hand pump hose from the brake release fitting (5).
6. Connect the brake release hose (4) to the brake release fitting (5).

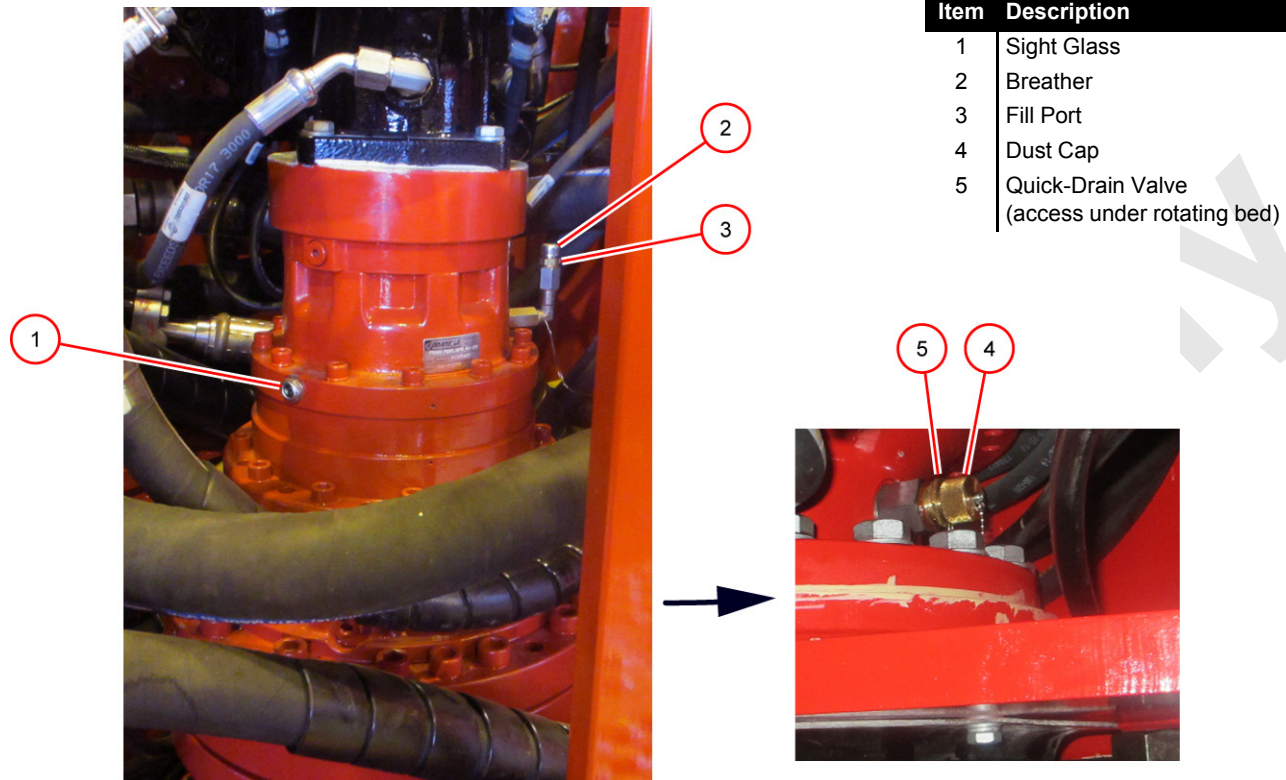

M101867

Figure 6-4. Swing Drive

SWING GEARBOX

The swing gearbox (Figure 6-4) is filled with gear oil. Maintenance consists of periodically checking the level and changing the oil.

Gear Oil Specifications

For gear oil specifications, see the Lubrication Guide supplied with the crane.

Oil Analysis

An oil analysis program is the best way to determine the optimal oil change interval and the condition of the swing gearbox.

Periodic Maintenance

Daily

Check the swing gearbox oil level every 8 hours of operation or daily, whichever comes first. The oil should be at the

middle of the sight glass (1). If necessary add oil through the fill port (3).

Initial Operation

Drain and refill the swing gearbox after the first 200 hours of operation.

Every 40 Hours or Weekly

Clean the swing gearbox breather (2) every 40 hours of operation or weekly, whichever comes first.

- Remove the breather.
- Soak the breather in non-flammable solvent and blow it clean and dry with compressed air.
- Reinstall the breather.

Every 6 Months or 1,000 Hours

Drain and refill the swing gearbox every 1,000 hours of operation or 6 months, whichever occurs first.

Quick-Drain Valve

The swing gearbox is equipped with a quick-drain valve which requires use of the quick-drain drainer assembly shown in [Figure 6-5](#). The quick-drain drainer assembly is stored in the parts box supplied with the crane.

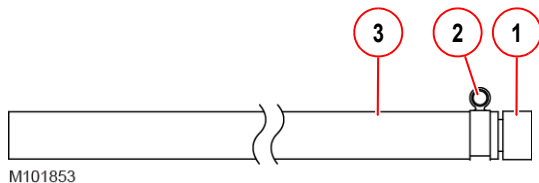

| Item | Description |
|------|--|
| 1 | Quick-Drain Drainer |
| 2 | Hose Clamp |
| 3 | Hose: 3/4 in (19 mm) Inside Diameter by 10 ft (3,0 m) Long |

Figure 6-5. Quick-Drain Drainer Assembly

Oil Change Procedure

The oil change interval may be adjusted according to the results of an oil analysis program.

Change the oil when the gearbox is warm, not hot.

NOTE To prevent harmful contaminants from entering the gearbox, thoroughly clean components before disconnecting or connecting them.

See [Figure 6-4](#) for the following procedure.

1. Lock out/tag out the crane.
2. Remove the dust cap (4) from the quick-drain valve (5).
3. Place the hose from the quick-drain drainer assembly ([Figure 6-5](#)) into a suitable container for collecting the drained oil: 2 gallons (7,5 L) of oil is required to fill a dry gearbox.

4. Thread the quick-drain drainer assembly all the way onto the quick-drain valve (5). The poppet inside the valve will open, allowing the oil to drain from the gearbox.
5. Once the gearbox has finished draining, remove the quick-drain drainer assembly.
6. Fasten the dust cap (4) to the quick-drain valve (5).
7. Fill the gearbox with specified oil:

MANUAL FILL PROCEDURE (very slow process)

- a. Remove the breather (2) from the fill port (3).
- b. Add oil through the fill port (3) using a suitable funnel until the oil level is halfway up the sight glass (1). Do not overfill.
- c. Reinstall the breather (2) in the fill port (3).

POWER FILL PROCEDURE (recommended)

- a. Remove the dust cap (4) from the quick-drain valve (5).
- b. Thoroughly clean the inside of the hose for the quick-drain drainer assembly.
- c. Thread the quick-drain drainer assembly all the way onto the quick-drain valve (5). The poppet inside the valve will open.
- d. Connect the hose from the quick-drain drainer assembly to a portable pump, either hydraulically powered or hand powered.
- e. Slowly pump oil into the gearbox until the oil level is halfway up the sight glass (1). Do not overfill.
- f. Once the gearbox is filled, remove the quick-drain drainer assembly.
- g. Fasten the dust cap (4) to the quick-drain valve (5).
8. Recheck the oil level after operating the swing drive. If necessary, add oil through the fill port (3).
9. Thoroughly clean the quick-drain drainer assembly and store it in the parts box.

THIS PAGE INTENTIONALLY LEFT BLANK

SECTION 7 POWER TRAIN

TABLE OF CONTENTS

| | |
|--|------|
| Batteries | 7-1 |
| Safety | 7-1 |
| Battery Gases Are Explosive | 7-1 |
| Jump-Starting a Battery | 7-1 |
| Causes of Battery Failure | 7-1 |
| Overcharging | 7-1 |
| Undercharging or Discharged | 7-1 |
| Lack of Water | 7-1 |
| Loose Hold-Downs | 7-2 |
| Overloads | 7-2 |
| Multiple Battery System | 7-2 |
| Maintenance | 7-2 |
| Checking Battery State-of-Charge | 7-2 |
| Troubleshooting—Slow Cranking | 7-3 |
| Quarterly Maintenance | 7-3 |
| Charging | 7-3 |
| Storage | 7-4 |
| Battery Disconnect Switch | 7-4 |
| Battery Charger | 7-4 |
| Engine Controls | 7-4 |
| Air Cleaner | 7-6 |
| Inspection | 7-6 |
| Daily | 7-6 |
| Monthly | 7-6 |
| Changing the Filters | 7-6 |
| Engine Throttle Adjustment | 7-8 |
| Hand Throttle Control | 7-8 |
| Foot Throttle Control | 7-8 |
| Foot Throttle Control Assembly and Calibration | 7-8 |
| Engine Enclosure | 7-10 |
| Engine Belt Routing | 7-10 |
| Engine Radiator | 7-11 |
| Checking Coolant Level | 7-11 |
| Draining and Filling Cooling System | 7-12 |
| Exhaust Aftertreatment System | 7-15 |
| DEF Tank | 7-15 |
| Coolant Solenoid Valve | 7-16 |
| Coolant Manifold | 7-16 |
| Air Bleed Valves | 7-16 |
| DEF Supply Module | 7-16 |
| SCR Module | 7-16 |
| Excessive NOx Warning System | 7-16 |
| Aftertreatment Protection System | 7-16 |
| DRT Module | 7-16 |
| DEF Dosing Module | 7-17 |
| DOC Module | 7-17 |
| DEF Heating and Cooling System | 7-17 |

THIS PAGE INTENTIONALLY LEFT BLANK

SECTION 7

POWER TRAIN

BATTERIES

Safety

 **WARNING**
Explosion Hazard

Batteries can explode with great violence and spraying of acid if a spark or flame is brought too close. The room or compartment in which batteries are stored must be ventilated and away from flames or sparks.

Chemical Burn Hazard

Battery electrolyte can cause severe burns. If electrolyte comes in contact with eyes, skin, or clothing, the area must be immediately flushed with large amounts of water.

Seek medical attention in event of an electrolyte burn.

Always wear eye protection when servicing batteries.

Battery Gases Are Explosive



Avoid sparks while charging batteries. Do not disturb the connection between the batteries until charger is turned off.

Another source of explosion lies in the reverse connection of the charging equipment. This hazard is present with all types of chargers, but particularly in the case of high-rate equipment. Carefully check the connections before turning on the charger.

Jump-Starting a Battery

Improper use of a booster battery to start a crane also presents an explosion hazard. To minimize this hazard, the following procedure is suggested:

1. Connect one end of each jumper cable to the proper battery terminals on the crane to be started. Do not allow the cable ends to touch.
2. Connect the positive cable to the positive terminal of the booster battery.
3. Connect the remaining cable to the frame or block of the starting vehicle. Never connect it to the grounded terminal of the starting vehicle.

Causes of Battery Failure

A battery should never be left in a discharged state. When discharged, it rapidly sulfates and, unless recharged within hours, will permanently lose capacity.

Overcharging

Overcharging is one cause of battery failure, and is most often caused by a malfunctioning voltage regulator.

Excessive heat is the result of overcharging. Overheating causes the plates to warp which can damage the separators and cause a short circuit within a cell. This bubbling and gassing of the electrolyte can wash the active material from the plates, reducing the battery's capacity or causing an internal short.

Undercharging or Discharged

Undercharging can cause a type of sulfate to develop on the plates. The sulfate reduces the battery capacity and causes strains in the positive plates which cause plate buckling. Buckled plates can pinch the separators and cause a short circuit.

Furthermore, an undercharged battery is not only unable to deliver power, but may freeze (see [Table 7-1](#)).

Table 7-1. Battery Freeze Points

| State of Charge | Specific Gravity | Freeze Point °F (°C) |
|-----------------|------------------|----------------------|
| 100% | 1.26 | -70 (-57) |
| 75% | 1.23 | -36 (-38) |
| 50% | 1.20 | -15 (-26) |
| 25% | 1.17 | -2 (-19) |
| 0% | 1.11 | 18 (-8) |

Lack of Water

The plates must be completely covered with electrolyte. If the plates are exposed, the high acid concentration will char and disintegrate the separators. The plates cannot take a full charge if they are not completely covered by the electrolyte.

| Item | Description |
|------|------------------------------------|
| 1 | Battery Hold-Down |
| 2 | 12V Batteries (connected parallel) |
| 3 | Battery Cover with Latches |

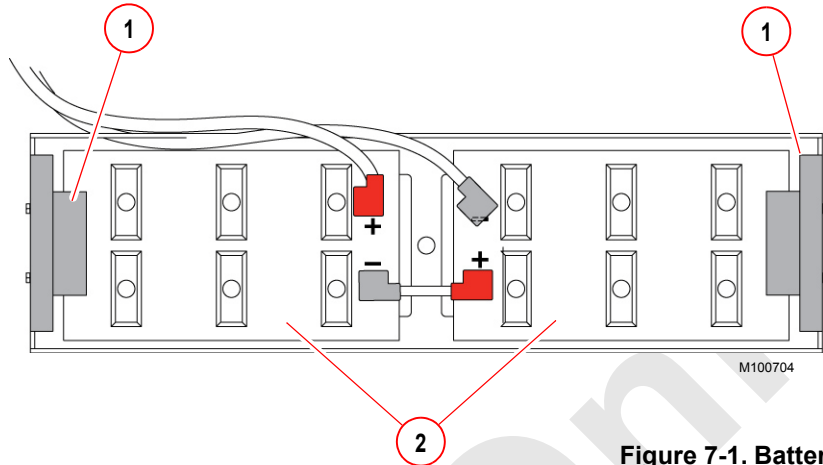
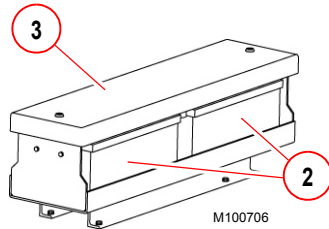

Figure 7-1. Batteries

Loose Hold-Downs

Loose hold-downs will allow the battery to vibrate in the holder. This can cause cracks or wear in the container and cause the acid to leak. Leaking acid corrodes terminals and cables, causing high resistance at the battery connections which weakens the battery. Hold-downs can also distort or crack the container.

Overloads

Avoid prolonged cranking or the addition of extra electric devices. These can drain the battery and may cause excessive heat.

Multiple Battery System

The crane's 24V system is powered by two 12V batteries connected in series ([Figure 7-1](#) and [Figure 7-4, page 7-5](#)).

Always refer to the wiring diagram for the correct connections. **Be careful not to reverse the battery connections.** Installing the batteries with electrical connections that are reversed will not only damage batteries but also the crane's electrical system, voltage regulator, and/or alternator.

Maintenance

CAUTION

Engine Damage!

To avoid possible engine faults and undesirable operation, make sure the engine ignition switch has been off five minutes before disconnecting the batteries.



WARNING

Personal Injury Hazard

Each battery weighs 130 lb (59 kg). Use proper lifting procedures.

Checking Battery State-of-Charge

Special equipment is required to properly determine the condition of a battery that has been in service. However, a voltmeter can be used to determine a battery's state-of-charge by checking the voltage between the battery terminals ([Figure 7-2](#)) ([Table 7-2](#)).

This open-circuit test is the simplest test but not as accurate in determining a battery's condition as a hydrometer test. The advantage is that the cell covers do not need to be opened, eliminating the possibility of cell contamination and electrolyte spill.

NOTE Do not use this test method if the battery has been recently charged by a charger or alternator. Recent charging places a high surface charge voltage which is not a true indication of actual battery voltage.

| Item | Description |
|------|---------------------------------|
| 1 | Test Leads on Battery Terminals |
| 2 | Voltmeter |

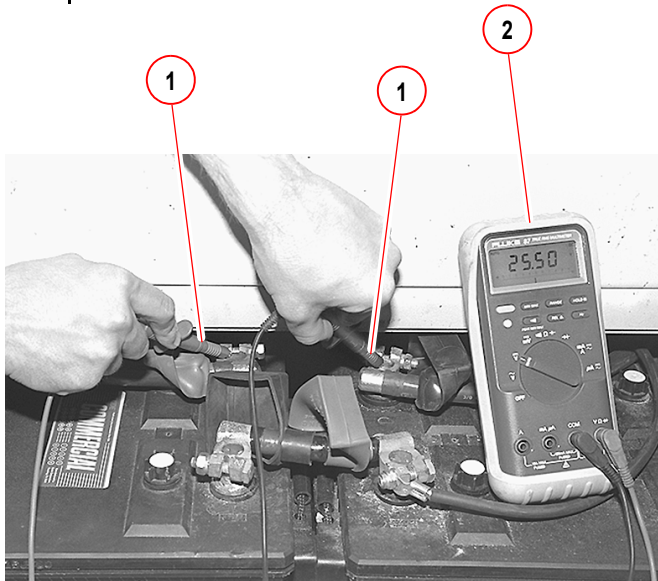

P1616

Figure 7-2. Checking Battery Voltage

Table 7-2. Open Circuit Voltage

| State-of-Charge | Specific Gravity | Approximate Open-Circuit Voltage (24V System) |
|-----------------|------------------|---|
| 100% | 1.260 | 25.2 |
| 75% | 1.230 | 24.8 |
| 50% | 1.200 | 24.4 |
| 25% | 1.170 | 24.0 |
| 0% | 1.110 | 23.6 |

Consult the manual provided with the test meter for detailed test information.

Troubleshooting—Slow Cranking

If the starter cranks too slowly and the battery is charged and in good condition, do a voltage-drop test to make sure that the starter connections are good.

When cranking, a voltage drop of more than 0.2 volts between the starting motor cable and ground can cause hard starting regardless of a battery's condition. The voltage drop can be caused by a poor contact between the cable terminal and ground or between the clamp terminal and the battery post. Also, poor start-switch contacts and frayed, broken, or corroded cables can be the cause.

Quarterly Maintenance

- Thoroughly clean the batteries and the holder with a baking soda/water solution.
- If provided, make sure the drain holes are open in the holder. If water collects in holder, drill some drain holes.
- Clean the posts and terminals. The posts can be lightly coated with petroleum jelly to prevent corrosion.
- Make sure that the hold-downs are in good condition. Replace faulty parts.
- Replace frayed, broken, or corroded cables.
- Replace the batteries if their containers are cracked or worn to the point that they leak.
- Ensure a good tight contact between the clamp terminals and the battery posts.
- Make sure the hold-downs are tight enough to prevent battery movement but not so tight to cause distortion.

Charging

NOTE If the crane is equipped with the optional charger, see [Battery Charger on page 7-4](#).

1. Remove the batteries or disconnect all the crane wiring from the batteries.
2. Read and follow the charger manufacturer's instructions.

Always wear eye protection when servicing batteries.

NOTE The battery should be at room temperature when recharging. Never attempt to recharge a frozen battery.

3. Clean the top of the battery to help prevent dirt entering the cells.
 4. Verify the plates are covered with electrolyte. If the level is low, add distilled water to bring the level just to top of the plates. Use a clean funnel. Re-check after charging.
- The maximum charge rate in amperes should be no more than 1/3 of the battery's reserve capacity minute rating.

NOTE The Deka 908D battery originally supplied with the crane has a reserve capacity rating of 430 minutes.

- Do not exceed 16 volts while charging (or 32V when charging two batteries in series).
- Charge until a 2-hour period results in no increase in voltage or decrease in current.

NOTE Overcharging will shorten a battery's life.

If battery becomes hot to the touch or if it gasses violently, temporarily halt charging or reduce charging current.

Storage

When the crane is left idle for prolonged periods, the batteries should be periodically charged.

When storing a battery, make sure it is least 75% charged to prevent sulfation and the possibility of freezing.

Follow your battery dealer's recommendations.

BATTERY DISCONNECT SWITCH

CAUTION

Avoid Engine Damage

To avoid possible engine fault codes and undesirable operation, make sure the ignition switch has been off five minutes before disconnecting the batteries.

The battery disconnect switch (1, [Figure 7-3](#)) is located in the right-side enclosure next to the engine Node 0.

| Item | Description |
|------|--------------------------------------|
| 1 | Battery Disconnect Switch |
| 2 | Disconnected (handle can be removed) |
| 3 | Connected |
| 4 | Engine Node 0 |

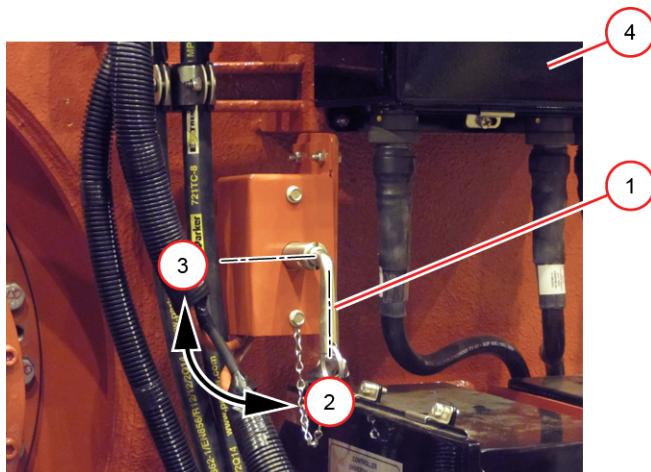

M102092a

Figure 7-3. Battery Disconnect Switch

The switch disconnects the engine controller (Node 0) from the positive side of the battery. Since the rest of the crane's control system is powered through Node 0, opening the disconnect switch effectively removes power from the entire control system.

To operate the battery disconnect switch:

- Turn handle COUNTERCLOCKWISE to DISCONNECT the control system to the battery (handle vertical and removable).

- Turn handle CLOCKWISE to CONNECT the control system from the battery (handle horizontal).

The following are reasons for using the disconnect switch:

- When servicing crane's electrical control system
- To help prevent the batteries from discharging when the crane is stored for extended periods of time
- To prevent the crane from being started by unauthorized personnel

CAUTION

Avoid Control System Damage

Before Welding:

- Disconnect the battery cables at the batteries.
- Disconnect the cabling from any control node enclosures that are in the vicinity of the welding.

Do not rely on the disconnect switch to protect the crane's electronic systems when welding.

BATTERY CHARGER

When a customer supplied 240VAC power source is connected to the receptacle (4, [Figure 7-4](#)), the optional battery charger will supply up to 10 amps of 24V power to the crane batteries.

If an alternative method of charging is desired, see [Charging on page 7-3](#).

If the crane is not to be used for more than a few days, the charger should be plugged in to a 240VAC source.

There is a 20A fuse on the DC output. For charger troubleshooting and maintenance information, refer to the manufacturer's service manual.

ENGINE CONTROLS

See the engine start procedure in Section 3 of the MLC165-1 Operator Manual for engine startup. See the Cummins engine manual for detailed engine instructions.

The engine is started and stopped with the engine key switch.

The speed of the crane motors and actuating cylinders depends on engine speed and equipment control handle movement. Engine speed is controlled with the hand throttle or foot throttle and is monitored with a speed sensor. Node 1 controller and engine Node 0 controller control and process engine information, which is shown on the main display.

The emergency stop push button stops the engine in an emergency. All brakes will apply and any functions will stop abruptly.

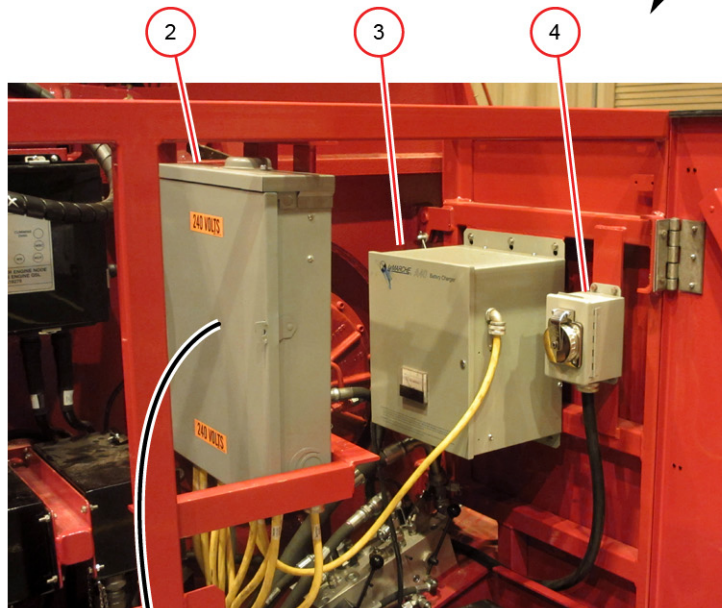
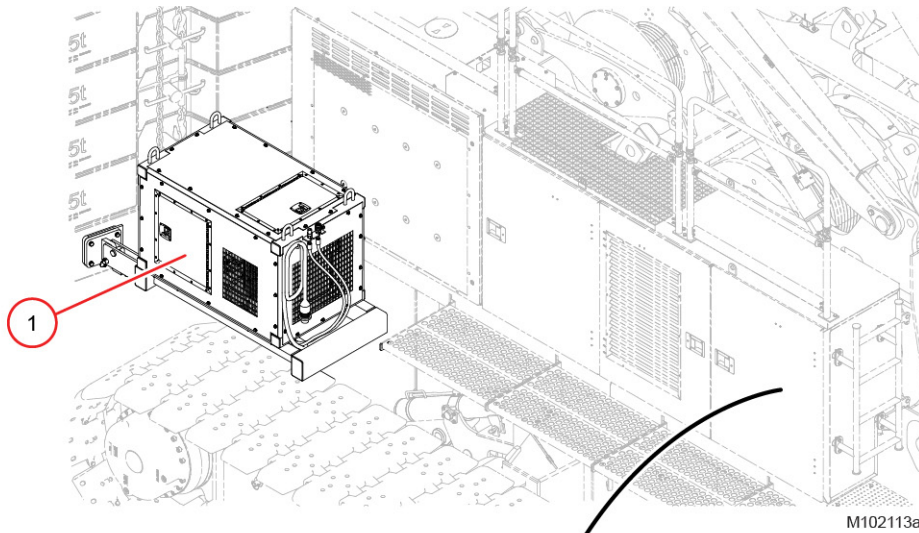

| Item | Description |
|------|--|
| 1 | 7.5 kW Generator with Power Supply Cord |
| 2 | Load Center |
| 2a | 50A Main Circuit Breaker |
| 2b | 15A Circuit Breaker: Rotating Bed Work Lights |
| 2c | 15A Circuit Breaker: Boom Work Lights |
| 2d | 15A Circuit Breaker: Engine Oil Heater, Battery Pad Heaters, and Engine Coolant Heater |
| 2e | 15A Circuit Breaker: Hydraulic Tank Heater |
| 2f | 15A Circuit Breaker: Cab Console Heater and Battery Charger |
| 3 | Battery Charger |
| 4 | 240 VAC Receptacle |

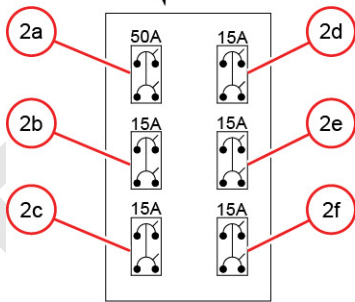

Figure 7-4. Battery Charger

CAUTION**Avoid Engine Damage**

- Stop engine before servicing the air cleaner. Otherwise, unfiltered air will be drawn directly into the engine. Never operate the engine without an air cleaner.
- Before servicing, clean the fittings, mounting hardware, and the area around the component(s) to be removed.
- Replace the secondary filter as quickly as possible to avoid engine ingestion of contaminants.
- Do not attempt to clean and reuse the old filters. Discard old filters and install new filters. Cleaning filter elements by impact or compressed air voids the warranty and can degrade or damage the filter media, leading to engine damage.

AIR CLEANER

See [Figure 7-5, page 7-7](#)

The air filters (10 and 11) require periodic maintenance.

- Clogged air cleaner filters will prevent adequate air flow to the engine, causing poor starting and increased exhaust emissions.
- An improperly installed or damaged air cleaner can allow dirty air to be drawn directly into the engine.

Either condition can cause engine damage.

Inspection

To maintain engine protection and filter service life, inspect the filters at the specified intervals:

Daily

Check the service indicator (3) with the engine running. The indicator gives a visual indication when it is time to replace the filters.

A yellow flag in the indicator window extends as the filters become plugged. Replace filters when yellow indicator reaches the red zone at the end of the indicator.

The yellow flag remains locked in place after the engine is stopped. The indicator reset button on the top of the indicator can be pressed at any time. When the engine is running, the indicator will return to the proper reading.

Monthly

- Inspect the steel tubes (5 and 8) and the rubber reducers (7 and 9) between the air cleaner and the engine for cracks or other damage which might allow

unfiltered air to enter the engine. Replace the worn or damaged parts.

- Check the housing (2) for dents or other damage that may allow unfiltered air to enter the engine. Replace the housing if damaged.
- Check for loose clamps (6). Tighten the loose parts.
- Inspect the inlet cap (1) for obstructions. Clean as required.

Changing the Filters

The air cleaner has two primary filters (10) and one secondary filter (11).

1. Remove the service cover (4) carefully.
2. Remove the primary filters gently in order to reduce the amount of dust dislodged. There will be some initial resistance, similar to breaking the seal on a jar. Using the tabs on the filters, move the end of filter back and forth to break seal.

Avoid dislodging dust from the filters.

NOTE The secondary filter should be replaced every third time the primary filters are replaced. Inspect the secondary filter and replace as necessary.

3. Remove the secondary filter by pulling on the plastic ring tabs.
4. Clean the sealing surfaces in the housing.

Use a clean cloth to wipe clean the sealing surfaces and inside of the housing. Dust on the sealing surfaces could render seal ineffective and cause leakage. Ensure all contamination is removed before new filters are installed.

5. Clean the inside of the outlet tube.

Carefully wipe the inside of the outlet tube with a clean cloth. Dirt accidentally transferred to the inside of the outlet tube will reach the engine and cause wear. It takes only a few grams of dirt to destroy an engine). Be careful not to damage the sealing area of the tube.

6. Visually inspect old filters for leaks. A streak of dust on the clean side of a filter is a telltale sign. Remove any cause of leaks before installing a new filter.
7. Inspect the new filters, especially the sealing area. Never install damaged filters.
8. Install a new secondary filter (11) (if required) carefully and gently push it into the back of the housing. Apply pressure to all four corners and tabs to make sure the filter is completely secure in the housing.
9. Repeat this step for the primary filters (10).

10. Install the service cover (4), making sure the O-ring is in place. Fasten the latches. The cover should go on without extra force. Push the reset button on the service indicator.

cover will do the job of sealing the filter, but it will not. Using latches to push filters in could damage the housing and will void the warranty.

Never use the latches on the cover to force the filters into the air cleaner. It is tempting to assume that the

| Item | Description | Item | Description | Item | Description |
|------|--------------------------------|------|----------------------------|------|--------------------|
| 1 | Air Inlet Cap with Pre-Cleaner | 5 | Steel Tube | 9 | Rubber Reducer |
| 2 | Air Cleaner Housing | 6 | Clamp (6 at various sizes) | 10 | Primary Filter (2) |
| 3 | Service Indicator | 7 | Rubber Reducer | 11 | Secondary Filter |
| 4 | Service Cover | 8 | Steel Tube | | |

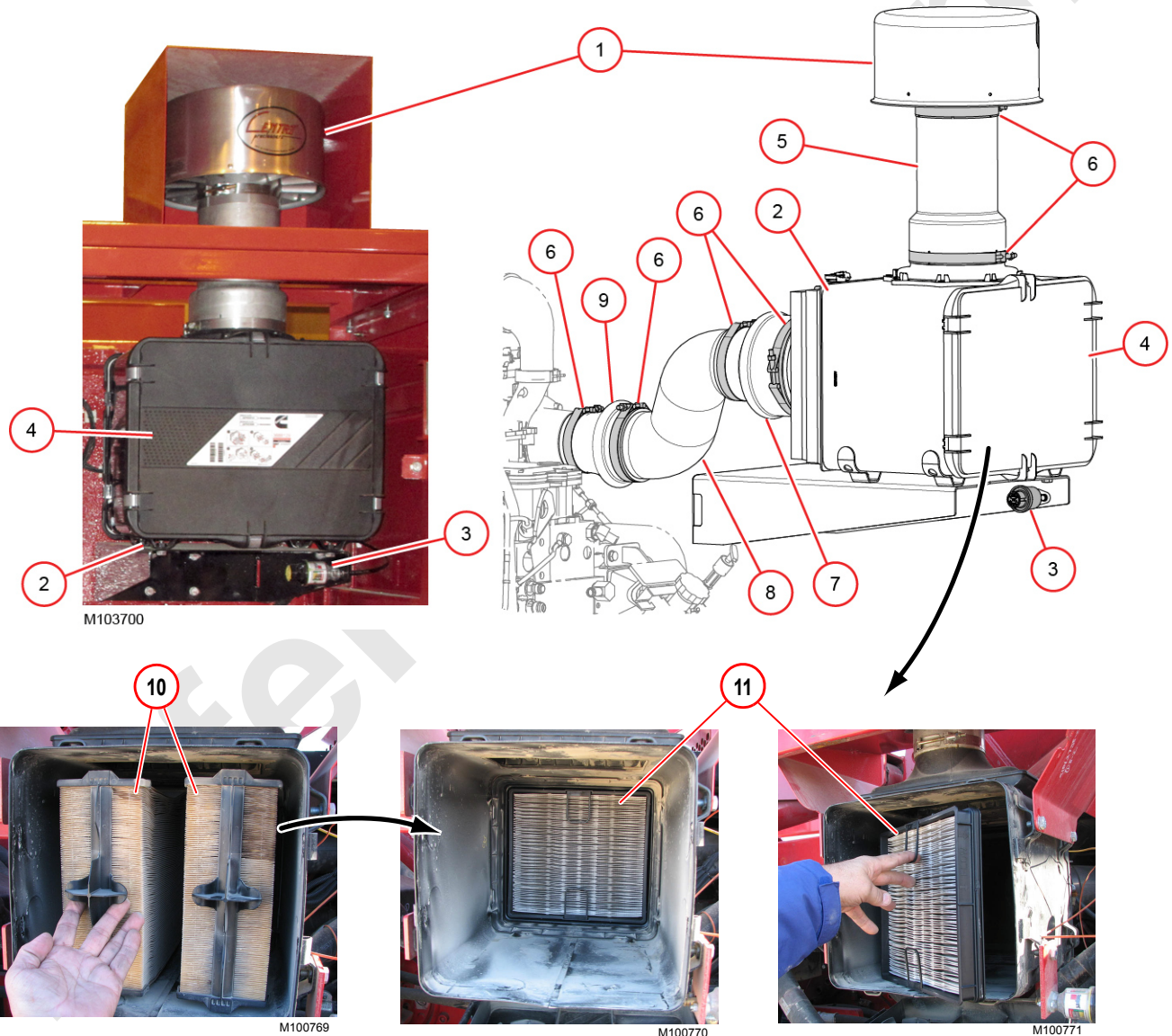

7

Figure 7-5. Air Cleaner

ENGINE THROTTLE ADJUSTMENT

The engine throttle assembly consists of an electronic hand throttle control in the left console and an electronic foot throttle control on the cab floor. There is no mechanical linkage between the throttle controls.

Electronic signals from the throttle controls are transmitted to the crane's programmable controller, and the programmable controller increases and decreases engine speed accordingly.

Hand Throttle Control

The hand throttle control does not require adjustment and is not repairable.

Foot Throttle Control

See [Figure 7-6, page 7-9](#).

If there is a problem with the foot throttle, it is best to either replace it or send the unit to the Manitowoc Crane Care Lattice Team for repair.

However, if field disassembly was done, use the following procedure to re-assemble and calibrate the throttle control.

NOTE The foot throttle control was properly assembled and calibrated at the initial installation and should not require further attention.

Foot Throttle Control Assembly and Calibration

Steps 1 through 7 must be done on a clean work bench.

1. To assemble the right-side shaft (3) and the torsion spring (5) into the housing (1), first assemble the spring onto the shaft by inserting the lug on one end of the spring into the hole in the head of the shaft.
2. Insert the shaft into the cavity in the bottom of the housing, through the bearing (8), and into the pedal (2).
Insert the lug on the other end of the spring (5) in the hole in the housing (Section A-A).
3. Insert the left-side shaft (4) into the cavity in the bottom of the housing, through the bearing (8), and into the pedal.

4. Rotate the pedal as needed and install the roll pins (10) through the holes in the pedal and the shafts (Pedal Position **A**).
5. Install the setscrew (14). Do not insert it deep enough to contact the head on the right-side shaft.
6. Rotate the pedal approximately 40° to position B (low idle). At this time, the flat on the head of the right-side shaft should be parallel with the surface X on the housing. Finish turning-in the set screw (14) until it contacts the flat on the head of the shaft (Section A-A).
7. Install the potentiometer (6) and calibrate the foot throttle:
 - a. Re-solder the control wires (11a, 11b, 11c) to the potentiometer and resistor leads.
 - b. With a supply voltage of 25.0 to 26.0 VDC, turn the potentiometer (6) shaft fully CCW as viewed from the shaft end (zero volts out).
 - c. With the pedal in Position B, insert the potentiometer into the cavity in the bottom of the housing as shown in View B-B. Insert the potentiometer shaft into the end of the left-side shaft (4) and tighten the set screw (15).
 - d. Rotate the pedal to the high idle position, hold in place using the set screw (14), and rotate the potentiometer housing to obtain an output of 0.90 to 1.00 VDC.
 - e. Apply silicone sealant RTV-162 between the housing and potentiometer. Do not get sealant on the shaft. Allow sealant to cure before proceeding to the next step.
 - f. After sealant has cured, check output for 0.90 to 1.00 VDC in high idle position.
 - g. Remove the set screw (14) and apply Loctite #243 to the threads. Install and adjust the set screw to obtain a low idle position output reading of 2.90 to 3.00 VDC.
8. Install the assembly onto the crane.

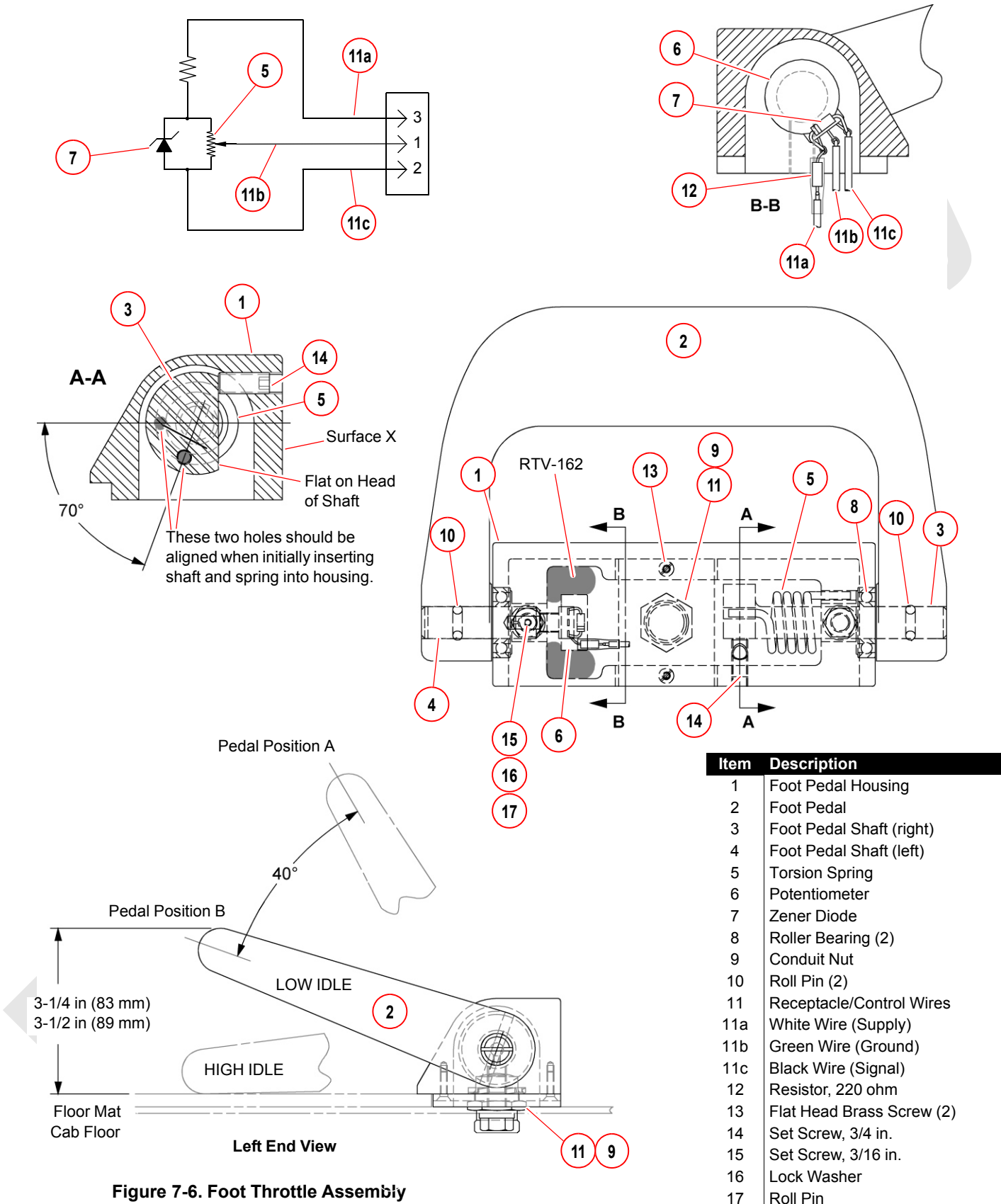

Figure 7-6. Foot Throttle Assembly

ENGINE ENCLOSURE

The engine components can be accessed from the doors, panels, and grating shown in [Figure 7-7](#)

Do not operate the crane without the grating and covers panels in place and all the fasteners secured.



WARNING

Personal Injury Hazard

Alert operator before going under rear of rotating bed. Operator, turn on swing park and do not swing while personnel are under rear of rotating bed.

To prevent serious injury, use the appropriate lifting equipment when lifting or removing grating or covers over engine.

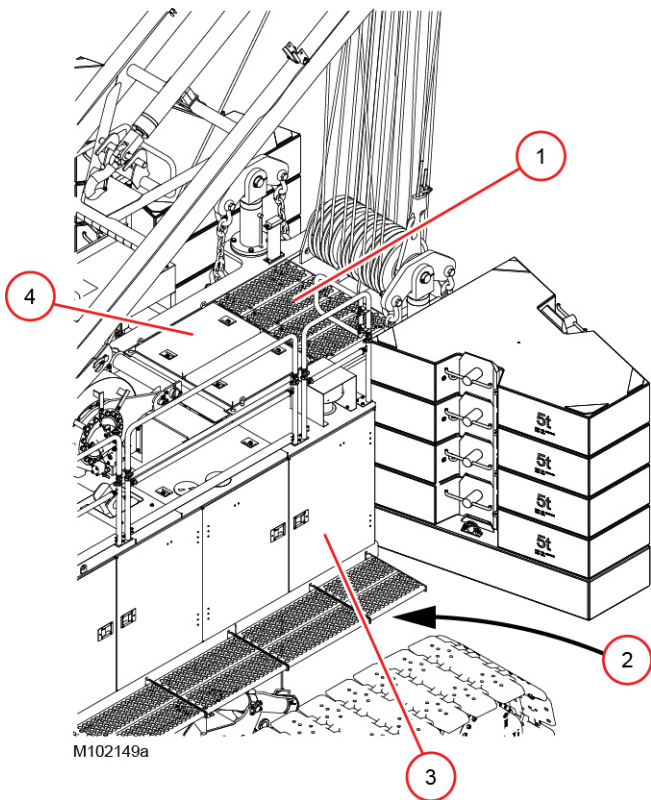

| Item | Description |
|------|--------------------------------------|
| 1 | Grating Assembly: 82 lb (37 kg) |
| 2 | Under Rear of Rotating Bed |
| 3 | Left-Rear Enclosure |
| 4 | Engine Cover (2): 33 lb (15 kg) each |

Figure 7-7. Engine Access

ENGINE BELT ROUTING

Engine belt routing is shown in [Figure 7-8](#) to help the service personnel when installing new belts on the engine.

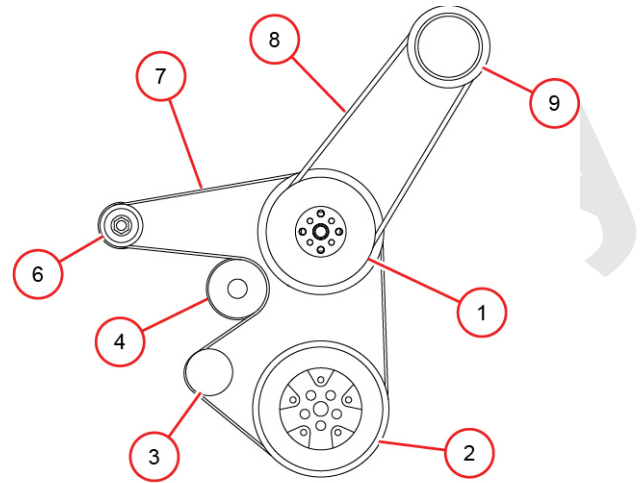

Tier 4 Final Engine

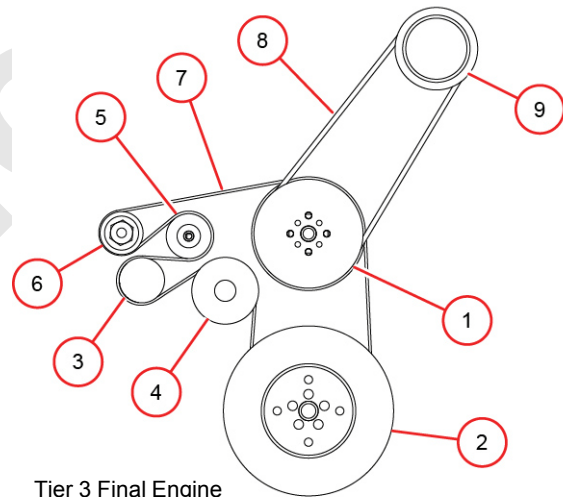

Tier 3 Final Engine

M103701

| Item | Description |
|------|----------------------------|
| 1 | Accessory Drive Pulley |
| 2 | Crankshaft Pulley |
| 3 | Tensioner |
| 4 | Water Pump |
| 5 | Idler |
| 6 | Alternator |
| 7 | Belt |
| 8 | Belt |
| 9 | Air Conditioner Compressor |

Figure 7-8. Engine Belt Routing

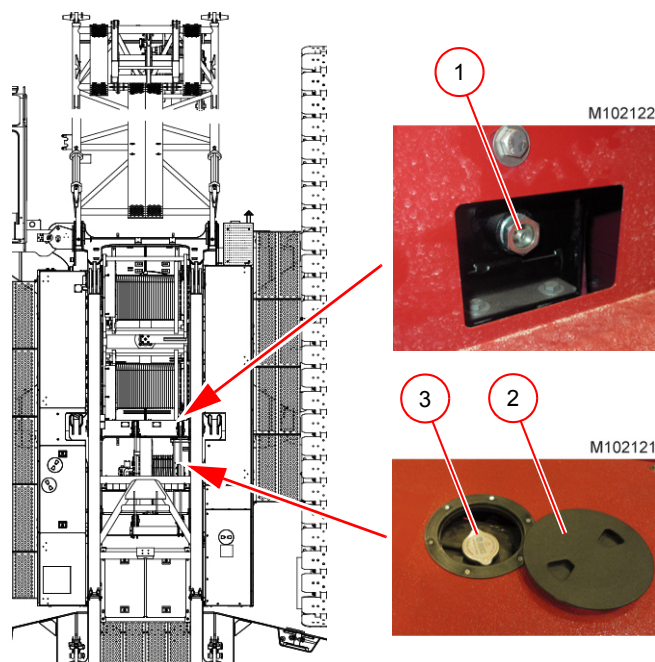

| Item | Description |
|------|-------------------|
| 1 | Level Sight Glass |
| 2 | Access Cover |
| 3 | Fill Cap |

Figure 7-9. Radiator Level and Fill

ENGINE RADIATOR



WARNING

Burn Hazard

Do not remove the radiator fill cap from a hot engine. Allow the engine to cool below 120° F (50° C) before adding the coolant.

Material Hazard

Coolant is toxic. Do not ingest. If not reused, dispose in accordance with all local and other applicable environmental regulations.

CAUTION

Avoid Engine Damage

The required coolant level must be maintained to prevent engine damage.

Checking Coolant Level

CAUTION

Maintain Coolant Additive

The required Supplemental Coolant Additive (SCA) concentration must be maintained to prevent engine damage.

Check the SCA concentration according to the schedule in the engine manufacturer's manual and per the manufacturer's warnings, cautions, and instructions.

See [Figure 7-9](#) for the following procedure.

Refer to the engine manufacturer's manual for additional cooling system maintenance instructions.

Check the coolant level every 8 hours of operation or daily (whichever occurs first) when the coolant is cold.

The coolant should be at the full cold mark on the decal next to the sight glass (1). Add coolant, as needed.

1. Remove the access cover (2).
2. Place a heavy dry cloth over the fill cap (3), then turn (do not depress) the fill cap until it stops at the safety detent.
3. Wait for the pressure to escape.
4. When the hissing stops, depress the cap, and turn it clockwise to remove.
5. Add coolant to the radiator. Stop several times to allow the coolant to flow into the engine and all portions of the radiator.
6. When the coolant is at the proper level in the sight glass, install the fill cap.
7. Run the engine until the normal operating temperature is reached.
8. When the engine is cool again, re-check the coolant level as described above. If needed, add coolant until it is at the proper level.
9. Install the fill cap and access cover.

Draining and Filling Cooling System

Drain the cooling system every 1,000 hours of operation or semi-annually (whichever occurs first).

The radiator is equipped with a quick-drain valve (2) which requires use of the quick-drain drainer assembly shown in [Figure 7-10](#). The quick-drain drainer assembly is stored in the parts box supplied with the crane.

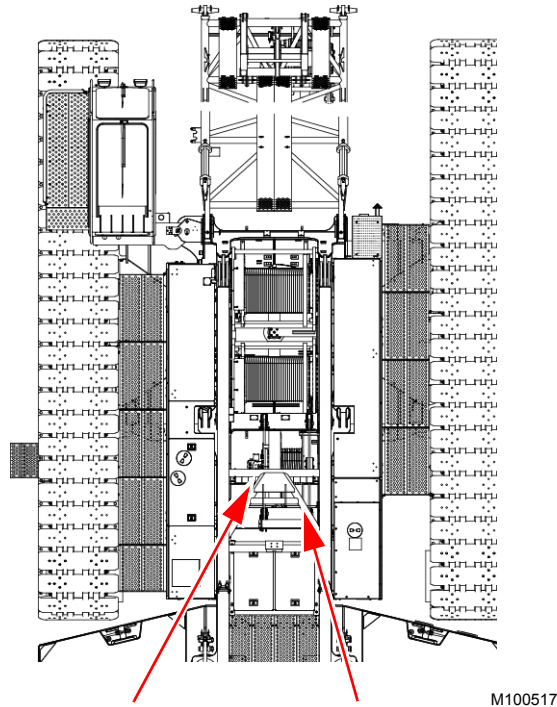

M100517

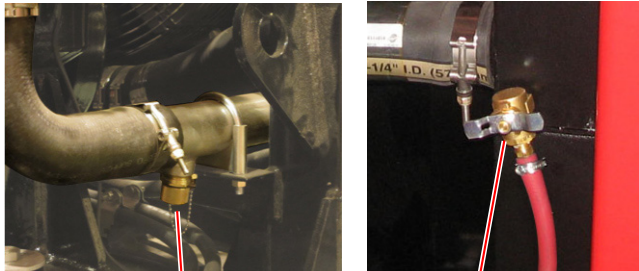

M102139

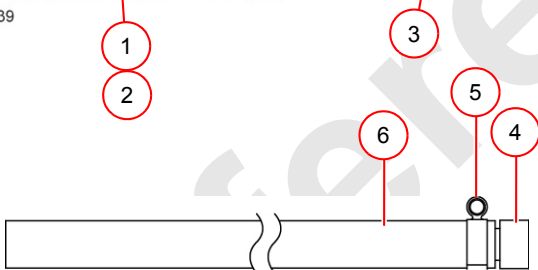

M101853

| Item | Description |
|------|--|
| 1 | Cap |
| 2 | Quick-Drain Valve (drains entire system) |
| 3 | Drain Valve (drains only radiator) |
| 4 | Quick-Drain Drainer |
| 5 | Hose Clamp |
| 6 | Hose: 3/4 in (19 mm) Inside Diameter by 10 ft (3,0 m) Long |

Figure 7-10. Radiator Drain Locations

1. Insert the quick-drain hose (6) into a suitable container which will hold 15 gal (57 L) of drained coolant.
 2. Remove the cap (1) and attach the quick-drain drainer (4) to the quick-drain valve (2).
 3. The fluid will drain.
 4. Remove the quick-drain drainer (4) from the quick-drain valve (2) when the system is completely drained.
 5. Install the cap (1).
 6. Thoroughly clean the quick-drain hose and store the assembly.
 7. Check that the cab heater valves on the engine are open.
 8. In the cab, place the heat control to maximum.
- NOTE** It is not necessary to turn on the heater fan.
9. Open the access cover and remove the radiator fill cap ([Figure 7-9, page 7-11](#)).
 10. Add a coolant additive (SCA) to the radiator.

CAUTION

Maintain Coolant Additive

A proper concentration of a Supplemental Coolant Additive (SCA) must be maintained to prevent engine damage.

Check the SCA concentration according to the schedule in the engine manufacturer's manual and per the manufacturer's warnings, cautions and instructions.

11. Add a 50-50 mix of water and ethylene glycol to the radiator.

NOTE The maximum fill rate is 3 GPM (11.4 liters/min).

NOTE The capacity of the cooling system is approximately 13 gal (49 L).

12. Once coolant is visible at the full cold mark on the decal next to the sight glass ([Figure 7-9, page 7-11](#)), wait 2-3 minutes, then add coolant again as needed.

**WARNING****Chemical and Burn Hazard**

Coolant could spray from an open radiator cap while the engine is running. Do not stand near the radiator while operating the engine with the pressure cap removed.

Coolant is toxic. Do not ingest. If not reused, dispose of in accordance with all local and other applicable environmental regulations.

13. Start the engine and run it until the thermostat opens at a coolant temperature of 181-199°F (83-93°C).
14. Reduce engine speed to low idle for two minutes to cool down the engine components, then turn off the engine.
15. Once the engine has cooled, add coolant until it is visible at the full cold mark on the decal next to the sight glass.
16. Install the fill cap and install the access cover.

Reference Only

Item Description

Components

- 1 DEF Tank
- 2 Coolant Flow Control Solenoid Valve
- 3 Coolant Manifold
- 4 Air Bleed Valves
- 5 DEF Supply Module
- 6 SCR Module
- 7 DRT Module
- 8 DEF Dosing Module
- 9 DOC Module

Coolant Hoses (BLUE)

- C1 From Coolant Manifold to DEF Tank
- C2 From DEF Tank to Coolant Manifold
- C3 From Engine
- C4 Return to Engine
- C5 From DRT Module to Coolant Manifold
- C6 From Coolant Manifold to DRT Module

DEF Hoses (GRAY)

- D1 DEF Suction
- D2 DEF Return
- D3 DEF Pressure

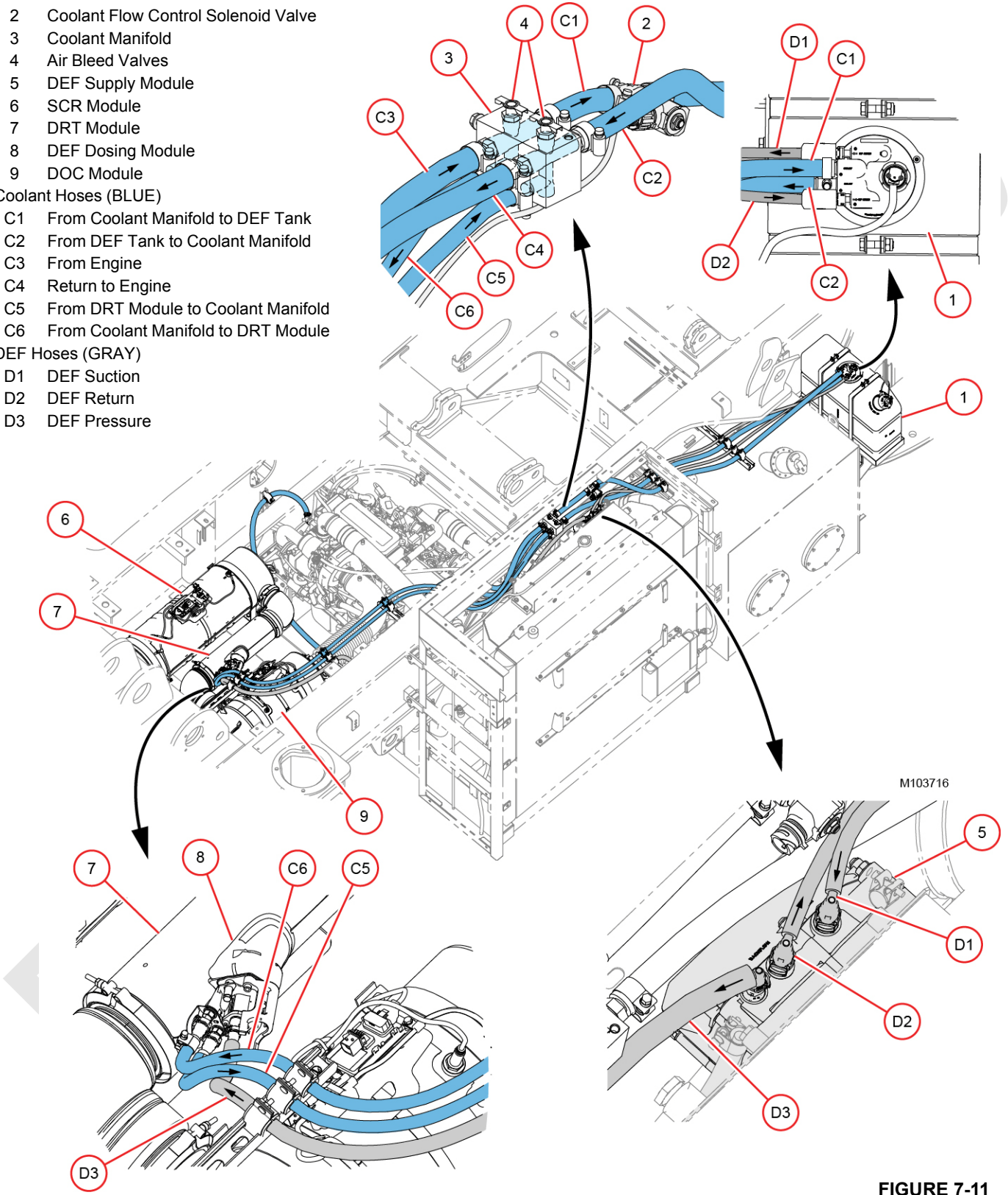

FIGURE 7-11

EXHAUST AFTERTREATMENT SYSTEM

See [Figure 7-11, page 7-14](#) for the following instructions.

| Abbreviation | Description |
|-----------------|--|
| APS | Aftertreatment Protection System |
| DEF | Diesel Exhaust Fluid |
| DOC | Diesel Oxidation Catalyst |
| dP | Dual Pressure |
| DRT | Decomposition Reactor Tube |
| ECM | Engine Control Module |
| HEST | Hugh Exhaust System Temperature |
| SCR | Selective Catalytic Reduction |
| NH ₃ | Ammonia |
| NO _x | Generic term for the mono-nitrogen oxides NO and NO ₂ (nitric oxide and nitrogen dioxide). They are produced from the reaction of nitrogen and oxygen gases in the air during combustion. |

WARNING

Hot Exhaust Surfaces and Inhalation Hazards

Extremely hot surfaces and exhaust gasses can cause death or serious injury. Allow engine and exhaust system to cool before servicing.

The engine exhaust is treated to significantly reduce the amount of harmful by-products of combustion from contaminating breathable air.

DEF Tank

The DEF tank (1, [Figure 7-11, page 7-14](#)) houses 10 gallons (38 L) of DEF. DEF consists of 32% urea and 68% de-ionized water. A constant mist of DEF, equal to 4.5% of the fuel used, is injected into the DRT module (7). This is about 10 gallons (38 L) of DEF for 1.5 tanks of fuel.

There is a 40-micron filter in the DEF supply line. For filter maintenance intervals and procedures, refer to the engine manufacturer's manual.

A drain valve is provided in case the tank needs to be emptied of poor-quality DEF.

| Item | Description |
|------|----------------------|
| 1 | DEF Tank |
| 2 | Fill Cap |
| 3 | DEF Return Port |
| 4 | DEF Coolant OUT Port |
| 5 | DEF Coolant IN Port |
| 6 | DEF Suction Port |
| 7 | Electric Plug |
| 8 | Drain Valve |

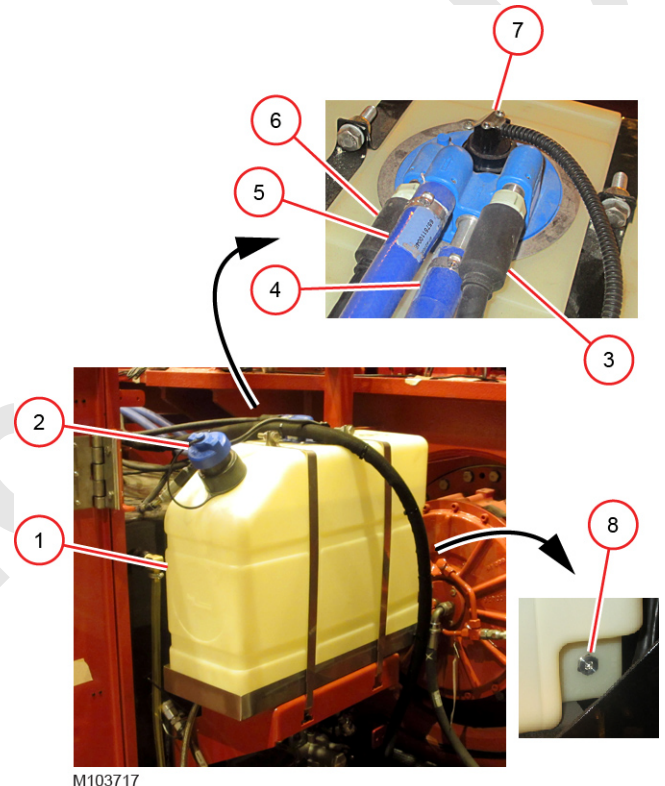

FIGURE 7-12

WARNING

Chemical Hazard!

DEF contains urea. Do not get DEF in your eyes. In case of contact, immediately flush eyes with large amounts of water for a minimum of 15 minutes. Do not swallow. In the event DEF is ingested, contact a physician immediately.

NOTE: Do not store DEF for long periods of time. DEF will deteriorate relative to time and temperature. Low-quality DEF may require the tank to be drained and the system purged.

CAUTION**Loss of Power or Engine Shutdown Hazard!**

If poor-quality DEF or a low-level condition is sensed, an error code will be activated. These conditions can lead to engine power being reduced (de-rated) by the ECM. If the condition persists, engine shutdown may occur.

Refer to the Main Display Operation Manual for identification and location of the engine and exhaust aftertreatment warning lights.

Coolant Solenoid Valve

When needed, the DEF is heated by engine coolant which is circulated through a heat exchanger in the tank. If the tank temperature drops below 25° F (-4° C), the ECM will open the coolant solenoid valve (2, [Figure 7-11, page 7-14](#)) to allow coolant to flow through the heat exchanger.

Coolant Manifold

The coolant manifold (3, [Figure 7-11, page 7-14](#)) routes coolant flow to the system.

Air Bleed Valves

The air bleed valves (4, [Figure 7-11, page 7-14](#)) are used to bleed air from the system when needed.

DEF Supply Module

The DEF supply module (5, [Figure 7-11, page 7-14](#)) is an electronically operated pump and metering system controlled by the ECM. The module pumps DEF to the dosing module (8) which is mounted on the DRT module (7).

At engine shutdown, the DEF supply module enters a purge cycle to prevent DEF from being left in the system, and in cold climates, from potentially freezing. When it is in the purge cycle, an audible click and pumping sound will be heard from the module, and the module will pull out all of the DEF in the system and return the DEF to the tank.

The DEF supply module is heated electrically and has a 10-micron filter that requires periodic cleaning and inspection. For filter maintenance intervals, refer to the engine manufacturer's manual.

**WARNING****Personal Injury or Equipment Damage Hazard!**

Do not remove hoses from or attempt to service the DEF supply module without first consulting the engine manufacturer's instructions. Personal injury and/or equipment damage may result.

CAUTION**Use Only Approved Replacement Parts!**

The DEF system components are designed to withstand freezing and to be compatible with DEF fluid and the other unique characteristics of the system. Use of non-approved replacement parts may result in system damage.

SCR Module

The SCR module (6, [Figure 7-11, page 7-14](#)) incorporates a catalyst, two temperature sensors, an NH₃ sensor, and a NO_x sensor.

The SCR module utilizes DEF (urea and deionized water) to reduce NO_x content in the exhaust gas to nitrogen.

The SCR module does not require maintenance.

Excessive NO_x Warning System**CAUTION****Loss of Power or Engine Shutdown Hazard**

If NO_x emissions exceed legislated limits, the operator will be alerted by warning lights and audible warnings. If the condition is not corrected in a set amount of time, an engine derate and shutdown sequence will begin.

Refer to the Main Display Operation Manual for identification and location of the engine and exhaust aftertreatment warning lights.

If an excessive NO_x warning is issued, check anything that might cause an elevated NO_x level, such as:

- Disconnected DEF tank level or quality sensor
- Blocked DEF hose or dosing module
- Disconnected dosing module
- Disconnected supply module
- Disconnected SCR wiring harness
- Disconnected NO_x sensor
- EGR valve malfunction

Aftertreatment Protection System

The APS continually monitors exhaust gas temperatures. In the event of excessive exhaust temperatures, the APS will illuminate the HEST lamp in the cab.

DRT Module

The DRT module does not require maintenance.

DRT (7, [Figure 7-11, page 7-14](#)) is a tube mounted between the DOC module (8) and the SCR module (6).

DEF Dosing Module

The DEF dosing module (8, [Figure 7-11, page 7-14](#)) injects a liquid mixture of urea and deionized water (called DEF) into the exhaust stream ahead of the inlet to the SCR module (6). Coolant lines run through the dosing module to keep it cool and operable.

DOC Module

The primary function of the DOC module (9, [Figure 7-11, page 7-14](#)) is to oxidize the remaining hydrocarbons in the exhaust to carbon dioxide. It incorporates a NO_x sensor, a dP sensor, and two temperature sensors.

The DOC module does not require maintenance.

DEF Heating and Cooling System

Warm coolant from the engine is routed to the coolant manifold (3, [Figure 7-11, page 7-14](#)) where it splits into two paths: one path delivers coolant to the heat exchanger in the DEF tank (1) to keep the DEF warm, and the other path

delivers coolant to the DEF dosing module (8) to keep it from overheating.

The coolant solenoid valve (2) adjusts coolant flow according to the temperature of the DEF in the DEF tank. If the tank temperature drops below 25° F (–4° C), the ECM will open the solenoid valve, and engine coolant will flow through the heat exchanger in the DEF tank.

To keep the DEF flowing during cold temperatures, two heating elements are provided: one in the DEF supply module and one in DEF line. The heating elements turn on if the ambient air temperature sensor reads a temperature below 25° F (–4° C).

The DEF dosing module (8) will not prime the system until every component is completely defrosted. If ambient conditions continue to be cold after the system has primed, the ECM will command a maintenance heating cycle to prevent the DEF system from refreezing. This feature will cycle the heating on and off to the DEF lines, DEF tank, and dosing module.

NOTE: DEF will freeze at 12° F (–11° C) and when frozen will expand by 10%. There are no approved additives to improve the freezing point.

THIS PAGE INTENTIONALLY LEFT BLANK

Reference Only

SECTION 8 UNDER CARRIAGE

TABLE OF CONTENTS

| | |
|--|-----|
| Travel Overview | 8-1 |
| Travel Enable | 8-1 |
| No Travel | 8-1 |
| Forward Travel | 8-1 |
| Reverse Travel | 8-1 |
| Travel Speed Selection | 8-1 |
| Turntable Bearing Maintenance | 8-5 |
| Installation | 8-5 |
| Torque Requirements | 8-5 |
| Lubrication | 8-5 |
| Torque Values | 8-5 |
| Torque Sequence | 8-5 |
| Re-Torque Intervals | 8-5 |
| Bolt Replacement | 8-5 |
| Crawler Preventative Maintenance | 8-7 |
| Crawler Tread Slack Measurement | 8-7 |
| Crawler Tread Slack Adjustment | 8-7 |
| Crawler Hand Pump and Jacking Cylinder | 8-8 |
| Assembly | 8-8 |
| Maintenance | 8-8 |
| Air Removal | 8-9 |
| Operation | 8-9 |

Reference Only

THIS PAGE INTENTIONALLY LEFT BLANK

SECTION 8

UNDER CARRIAGE

TRAVEL OVERVIEW

See [Figure 8-1](#) and [Figure 8-2](#)

Travel Enable

The travel pilot controls whether or not pilot pressure is ported to the travel control handle. This acts as a function enable for the travel handle. Two conditions must be met for node 4 to drive the travel pilot valve:

- Seat safety switch must be closed
- Travel parking switch is in the off position

When these conditions are met, node 4 sends a 24Vdc signal to the travel pilot valve relay. The travel pilot valve moves the open position, porting fluid to the P connection of the control handle.

No Travel

When the control handle is in the neutral position, no fluid is ported to the control valve pilots (a4 and b4). The valve remains in the center position, blocking flow from the pump to the crawler motor. The crawler brake also receives no pressure and remains engaged.

Forward Travel

Travel handle movement to the forward direction ports fluid to the control valve pilot a4 line. The valve moves to the open position and ports fluid from A4 to the P1 connection of the crawler motor. At the crawler motor valve, flow from the P1 connection creates a pilot flow that moves the valve to the open position. Fluid is ported to the brake, releasing it, and to

the motor, rotating it. Fluid flows from the motor, back through the open motor valve P1 connection, through the open control valve B4 connection, and back to tank.

Reverse Travel

Travel handle movement to the reverse direction ports fluid to the control valve pilot b4 line. The valve moves to the open position and ports fluid from B4 to the P2 connection of the crawler motor. At the crawler motor valve, flow from the P2 connection creates a pilot flow that moves the valve to the open position. Fluid is ported to the brake, releasing it, and to the motor, rotating it. Fluid flows from the motor, back through the open motor valve P1 connection, through the open control valve A4 connection, and back to tank.

Travel Speed Selection

Travel speed is selected by the travel speed selection switch in the cab. Node 2 sends a 24Vdc output to the travel speed selection switch. The switch is open in the low speed travel position, so node 2 reads back a 0Vdc signal from the switch. Node 4 sends a 0Vdc output to the travel speed valve solenoid, de-energizing it. The valve remains closed, no fluid flows to the servo pistons, and the swashplate remains in the low speed position.

The switch closes in the high speed travel position, so node 2 reads back a 24Vdc signal from the switch. Node 4 sends a 24Vdc output to the travel speed valve solenoid, energizing it. The valve moves to the open position, fluid flows to the servo pistons, and the swashplate moves to the high speed position.

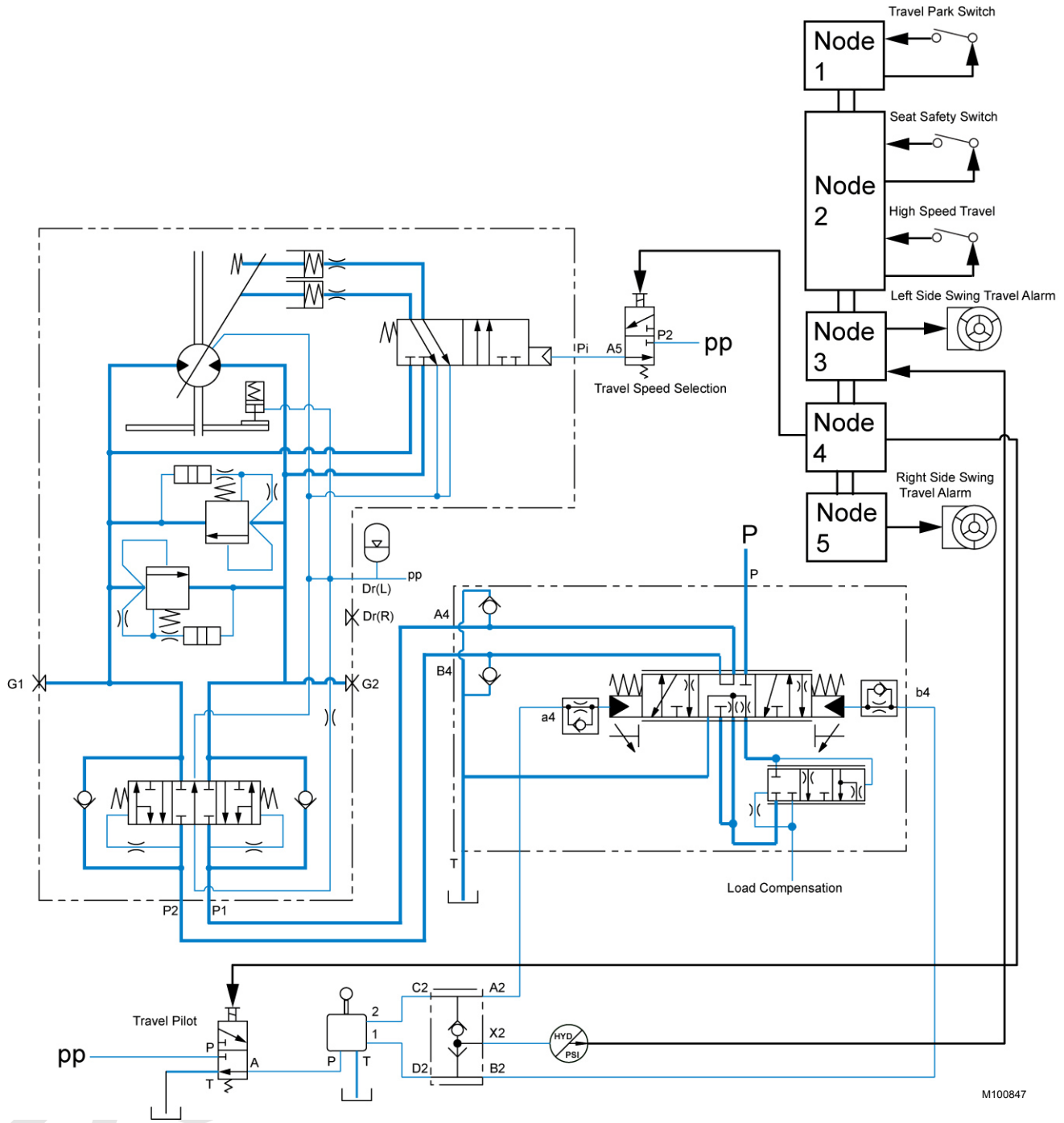
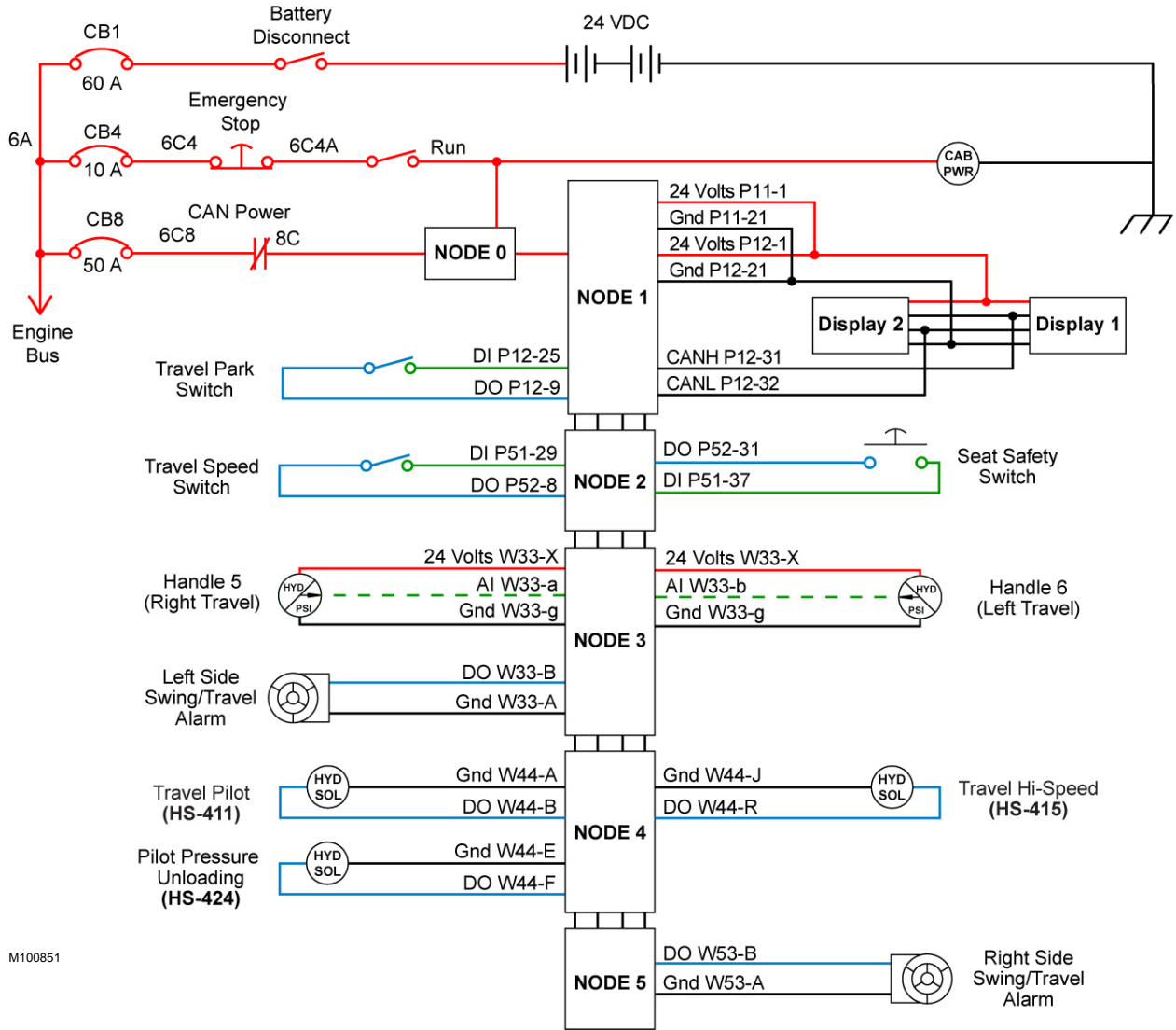

Figure 8-1. Travel Control (Left Crawler)



M100851

Refer

Figure 8-2. Travel Electrical Diagram

M103718

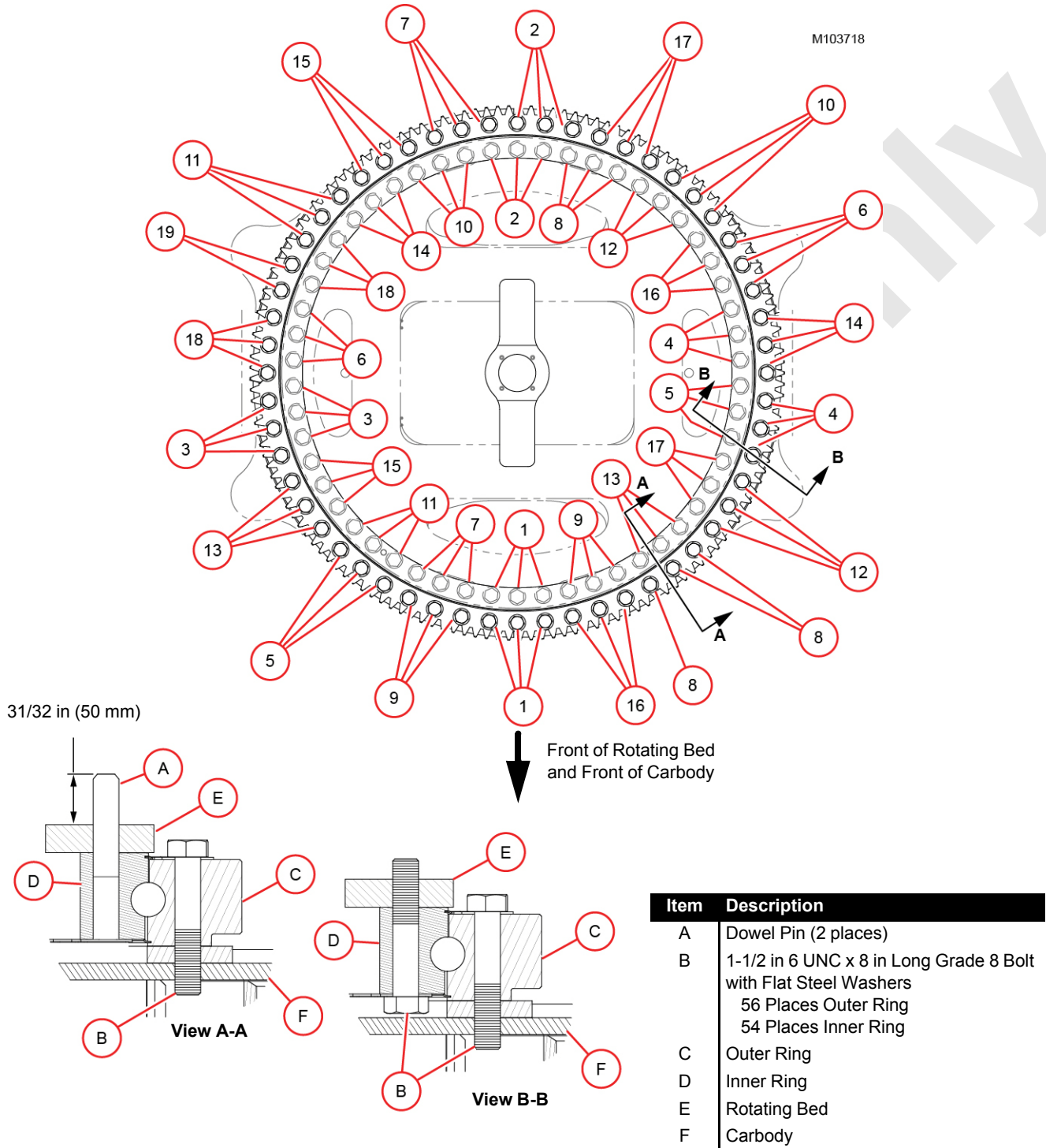

Figure 8-3. Turntable Bearing Bolts

TURNTABLE BEARING MAINTENANCE

See [Figure 8-3](#) on the previous page.



DANGER

Crushing Injury Hazard

Two people are required to install and tighten the turntable bearing bolts: an operator to operate swing control and a mechanic to torque the bolts.

The mechanic must go inside of the rotating bed to torque the inner turntable bearing bolts.

- Maintain constant communication between the operator and mechanic while the mechanic is inside the rotating bed.
- The operator shall not swing the upperworks until instructed to do so by the mechanic.
- The mechanic shall stay well clear of moving parts while the upperworks are being swung to position the bolts.

Installation

The **S** in the outer ring (C) must be on the right side of the carbody.

Two dowel pins are installed in the inner ring (D) as shown in View A-A to locate the position of the inner ring on the rotating bed. The **S** in the inner ring will be on the left side of the of the rotating bed.

When installing the dowel pins (A, View A-A), secure them at the dimension shown with Loctite® 271 or equivalent thread locking compound.

Torque Requirements



WARNING

Bolt Failure!

Loose or improperly torqued bolts can cause the bolts or the turntable bearing to fail, possibly allowing the rotating bed to break away from the carbody.

Lubrication

Before installing the turntable bearing bolts (B, View B-B), lubricate the threads of each bolt and both sides of the washers with "Never-Seez" or equivalent anti-seizing lubricant.

Torque Values

Torque each turntable bearing bolt to 2,100 ft-lb (2,848 Nm).

When new bolts are installed, torque them in the numbered sequence given in two steps:

- Initial torque - 600 ft-lb (814 Nm)
- Final torque - 2,100 ft-lb (2,848 Nm)

Torque Sequence

Torque three bolts at a time (two at item 19) in the numbered sequence given.

Re-Torque Intervals

INITIAL OPERATION: re-torque all bolts to the specified torque value after the first 50 hours of operation.

YEARLY OR EVERY 2,000 HOURS OF OPERATION (whichever comes first): re-torque all bolts to the specified torque value.

Bolt Replacement

If, at the yearly re-torque interval, one or more bolts are found to be torqued to less than 1,680 ft-lb (2 278 Nm), replace each loose bolt. Also replace the bolt and washer on each side of each loose bolt.

If, at the yearly re-torque interval, 11 or more bolts in either ring are found to be torqued to less than 1,680 ft-lb (2 278 Nm), replace all of the bolts and washers for the corresponding ring.

Replace all of the bolts and washers each time a new turntable bearing is installed.

See View B for items 12 and 13.

| Item | Description |
|------|--|
| 1 | Bolt and Nut |
| 2 | Cover |
| 3 | Jack Cylinder |
| 4 | Support |
| 5 | Rod |
| 6 | Shim - 0.134 in (3,4 mm) Shim 0.250 in (6,4 mm) |
| 7 | Tread |
| 8 | Front Crawler Roller |
| 9 | Hand Pump |
| 10 | Center Punch A |
| 11 | Center Punch Line B |
| 12 | Straight Edge |
| 13 | Gap: 1 in (25 mm) Tight Limit 2.2 in (55 mm) Loose Limit |

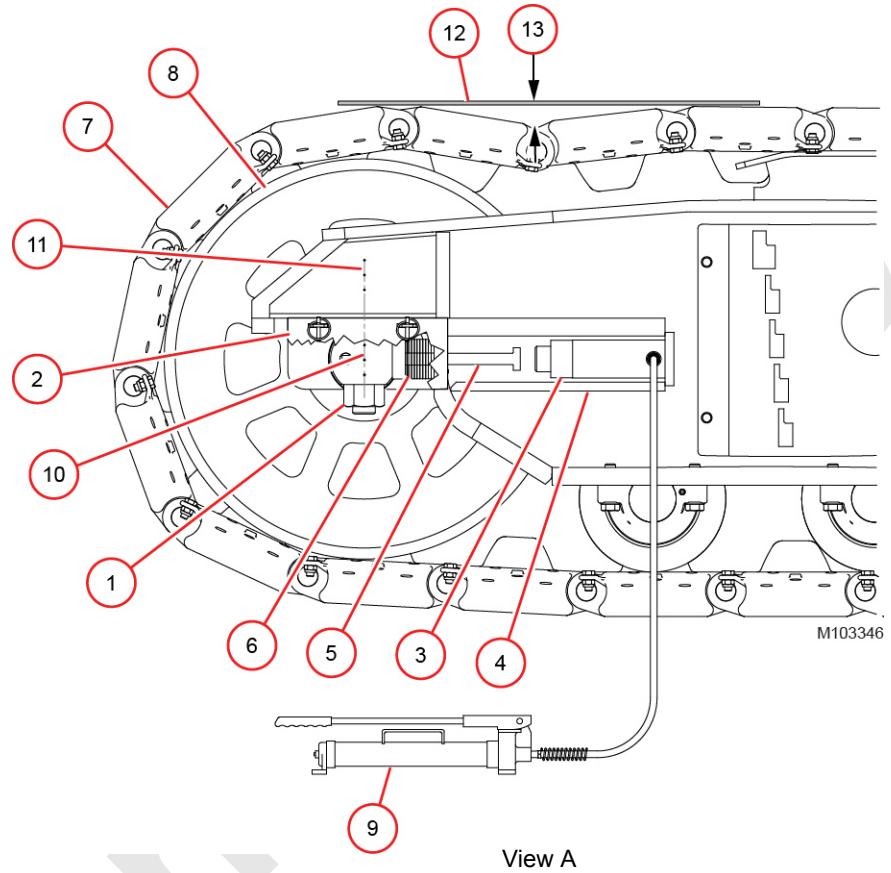

Pin Keeper Bolt



View B

IMG1425

Figure 8-4. Crawler Slack Measurement and Adjustment

CRAWLER PREVENTATIVE MAINTENANCE

Crawler wear cannot be eliminated, but the rate of wear can be reduced through regular preventive maintenance. Repair or replace damaged parts immediately to prevent further damage.

- Lubricate the crawlers as instructed in Lubrication Guide supplied with the crane.
- Keep the crawlers clean and avoid dirt build-up when cutting.
- Keep all mounting bolts tight (see Parts Manual for applicable torque values).
- Keep the treads properly adjusted.
- Inspect the crawler frames, rollers, and treads on a regular basis.
- Check for oil leaks, excessive wear, cracks, and other damage. Broken or cracked parts can indicate that the treads are adjusted too tightly.

CRAWLER TREAD SLACK MEASUREMENT

See [Figure 8-4](#) for the following procedure.

Check the tread slack at roller end of each crawler. Maintain equal tread slack at both crawlers.

1. Position the crane to travel with tumblers leading in direction of travel. Do not travel with front rollers leading.
2. Travel on a firm level surface until maximum amount of slack can be seen (about half of one crawler length).
3. Place a straight edge (13) on top of the tread. Measure the gap (14) between the straight edge and the head of the pin keeper bolt.
4. If the gap exceeds the limits listed below, adjust the crawler tread slack as described in the following procedure.
 - 1.0 in (25 mm) Tight Limit
 - 2.2 in (55 mm) Loose Limit

NOTE In order to obtain the most accurate measurement possible, stop the tracks at different locations to check multiple positions of the pads relative to the frame.

CAUTION

Tread Pin Damage

Do not adjust the treads too tight or the tread pins will wear rapidly and may break. Dirt build-up will tighten the treads further, increasing the possibility of damage.

Tight treads require more drive torque, resulting in faster wear and increased fuel consumption.

CRAWLER TREAD SLACK ADJUSTMENT

See [Figure 8-4](#) for the following procedure.

Adjust the treads tighter when operating on firm ground and looser when operating on soft ground (mud or sand).

Adjust tread slack at the roller end of each crawler.

1. Thoroughly clean the crawler to be adjusted.
2. Remove the covers (2) from both sides of crawler frame.
3. Loosen the nut (1) on each side of the crawler roller (8).
4. Place the jacking cylinder (3) on the support (4).
5. Using the hand pump, extend the jacking cylinder (see Operation on [page 8-9](#)) against the rod (5) equal distances at both sides of the crawler frame.
6. Add or remove an equal thickness of shims (6a & 6b) on both sides of crawler frame.
7. Relieve the pressure in the jacking cylinder and remove it.
8. Travel the crane forward or reverse to tighten the shims.

CAUTION

Parts Wear

The crawler roller and tumbler must be square with the crawler frame to within 1/8 in (3 mm), or parts will wear rapidly.

9. Verify that the left and right crawler dimensions, measured from the center punch in the shaft (10) to the center punch line in the crawler frame (11), are within 1/8 in (3 mm) of each other.
10. Check for proper crawler slack adjustment and readjust as required ([step 4](#) through [step 9](#)).
11. Lubricate the nuts and bolts at the crawler rollers with Never-Seez or an equivalent anti-seizing lubricant.
12. Tighten the nut on the bolt to 1,000 ft-lb (1,356 Nm).
13. Install the cover (2) on both sides of crawler frame.

NOTE The extreme limit of tread adjustment occurs when the bolts are tight against front end of the slots in crawler frame. One crawler tread can be removed when this limit is reached.

CRAWLER HAND PUMP AND JACKING CYLINDER



WARNING Hand Pump Explosion

The hand pump and cylinder is provided for crawler adjustment only, any other use is neither intended nor approved.

Wear safety glasses and other personal protective gear when operating the hand pump.

Do not set the pump relief valve higher than 10,000 psi (700 bar). Higher pressure can cause components to explode.

The pump is not vented. It can explode if subjected to high pressure. Do not attempt to return more oil to the pump than it is capable of holding. Do not overfill the pump.

In some cases, the pump handle can "kickback." Always keep your body to side of pump, away from line of handle force.

Do not add extensions to handle. Extensions can cause unstable operation.

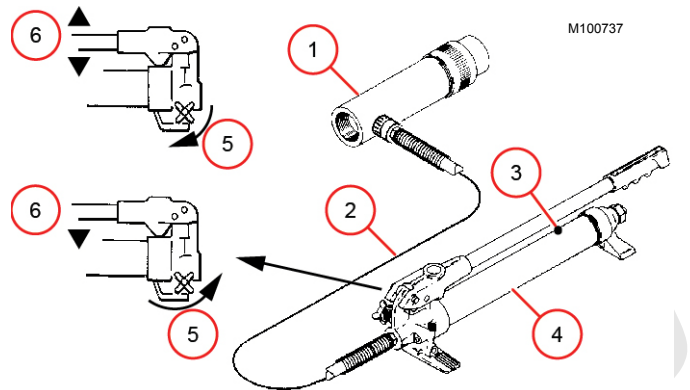

| Item | Description |
|------|------------------|
| 1 | Jacking Cylinder |
| 2 | Hose |
| 3 | Vent Fill Cap |
| 4 | Pump |
| 5 | Valve |
| 6 | Jacking Handle |

Figure 8-5. Crawler Hand Pump

Assembly

1. Connect the hose from the pump outlet port to the cylinder inlet (Figure 8-5).

CAUTION Hand Pump Damage

Do not apply sealant to the first complete thread to ensure the sealant does not shed into the hydraulic system and cause malfunctioning or damage.

2. Apply 1-1/2 wraps of a high-grade thread sealant (Teflon tape) to the fittings.

CAUTION Leaks and Fitting Damage

Do not overtighten the connections, connections only need to be snug and leak free. Overtightening can cause premature thread failure and may cause fittings or castings to split at lower than their rated pressures.

Maintenance

See Figure 8-5 for the following procedure.

1. Keep the unit clean and stored in a safe place where it cannot be damaged.
2. Assure correct pump oil level. To check the level:
 - a. Turn the pump valve (5) counter-clockwise, push the jacking handle (6) all the way down, and fully retract the jacking cylinder (1) rod to return all oil to the pump. **The cylinder must be fully retracted or the system will contain too much oil after filling.**
 - b. Place the pump (4) horizontally on a flat surface.
 - c. Using a screw driver, remove the vent fill cap (3).
 - d. Add hydraulic oil to the pump until the reservoir is two-thirds full. **Do not overfill.**
 - e. Reinstall the vent fill cap.
 - f. Test pump operation and remove air from system, if required. Recheck oil level after removing the air.

Air Removal

See [Figure 8-5](#) for the following procedure.

1. Rotate the valve (5) clockwise until finger tight.
2. Position the pump (4) so it is higher than the cylinder (1) and position the cylinder so the rod is down.
3. Operate the jacking handle (6) up and down to fully extend the jacking cylinder (1) rod.
4. Rotate the valve (5) counterclockwise, push the jacking handle (6) all the way down, and fully retract the jacking cylinder (1) rod to force oil and trapped air back into the pump.
5. Repeat this procedure until the cylinder operates smoothly. **Erratic operation indicates air in the system.**

Operation

1. Before using the pump:
 - Check that all fittings are tight and leak free.
 - Check the oil level.
2. To pressurize the jacking cylinder (1) and extend the rod, close the valve (5) by turning it clockwise until finger tight. Pump the jacking handle (6) up and down. Pressure is maintained until the valve is opened.

To reduce the handle effort at high pressure, use short strokes, maximum leverage is obtained in last five degrees of stroke.
3. To de-pressurize the jacking cylinder (1), push the jacking handle down fully and then open the valve (5) by turning it counterclockwise.
4. The pump can be operated in any position from horizontal to vertical as long as the **hose end of the pump is down.**

THIS PAGE INTENTIONALLY LEFT BLANK

SECTION 9 LUBRICATION

TABLE OF CONTENTS

| | |
|--------------------------------------|-----|
| Lubrication | 9-1 |
| Lube and Coolant Product Guide | 9-1 |

Reference Only

THIS PAGE INTENTIONALLY LEFT BLANK

SECTION 9 LUBRICATION

LUBRICATION

See F2278 at the end of this section.

LUBE AND COOLANT PRODUCT GUIDE

See the publication at the end of this section.

Reference Only

THIS PAGE INTENTIONALLY LEFT BLANK

Reference Only

SECTION 10 ACCESSORIES

TABLE OF CONTENTS

| | |
|------------------------------------|------|
| Accessory System Pressure | 10-1 |
| Carbody Theory of Operation | 10-1 |
| Jack Cylinders | 10-2 |
| Neutral | 10-2 |
| Extend | 10-2 |
| Retract | 10-2 |
| Pin Pullers | 10-2 |
| Neutral | 10-2 |
| Extend | 10-2 |
| Retract | 10-2 |
| Rotating Bed Cylinders | 10-3 |
| Mast | 10-5 |
| Neutral | 10-5 |
| Raise | 10-5 |
| Lower | 10-5 |
| Assembly Cylinder (Optional) | 10-6 |
| Neutral | 10-6 |
| Extend | 10-6 |
| Retract | 10-6 |
| Boom Butt Pin Pullers | 10-7 |
| Neutral | 10-7 |
| Engage | 10-7 |
| Disengage | 10-7 |
| Counterweight Cylinders | 10-7 |
| Neutral | 10-7 |
| Raise | 10-7 |
| Lower | 10-7 |
| Counterweight Pin Pullers | 10-8 |
| Neutral | 10-8 |
| Disengage | 10-8 |
| Cab Tilt | 10-9 |
| Neutral | 10-9 |
| Raise | 10-9 |
| Lower | 10-9 |

Reference Only

THIS PAGE INTENTIONALLY LEFT BLANK

SECTION 10 ACCESSORIES

ACCESSORY SYSTEM PRESSURE

All of the accessory system functions are operated at 3,400 psi (234 bar) and 100% displacement of the accessory pump. All control comes from the manual handles.

CARBODY THEORY OF OPERATION

The carbody valves are handle-actuated spring-centered proportional valves that control:

- Jack cylinders
- Carbody pin puller cylinders

The accessory pump provides flow to the carbody valve manifold. Flow from the accessory pump flows to the lower accessory valve. The lower accessory valve is normally closed, providing no flow to the lower accessories. When the operator commands supply fluid to the lower works from the

user interface, node 5 sends a 24Vdc signal to the lower accessory valve solenoid, energizing it. The valve moves to the open position and fluid flows through the valve, through the swivel, and on to the lower carbody valve block. At the lower carbody valve block, handle-actuated spring-centered proportional valves drive the individual cylinders.

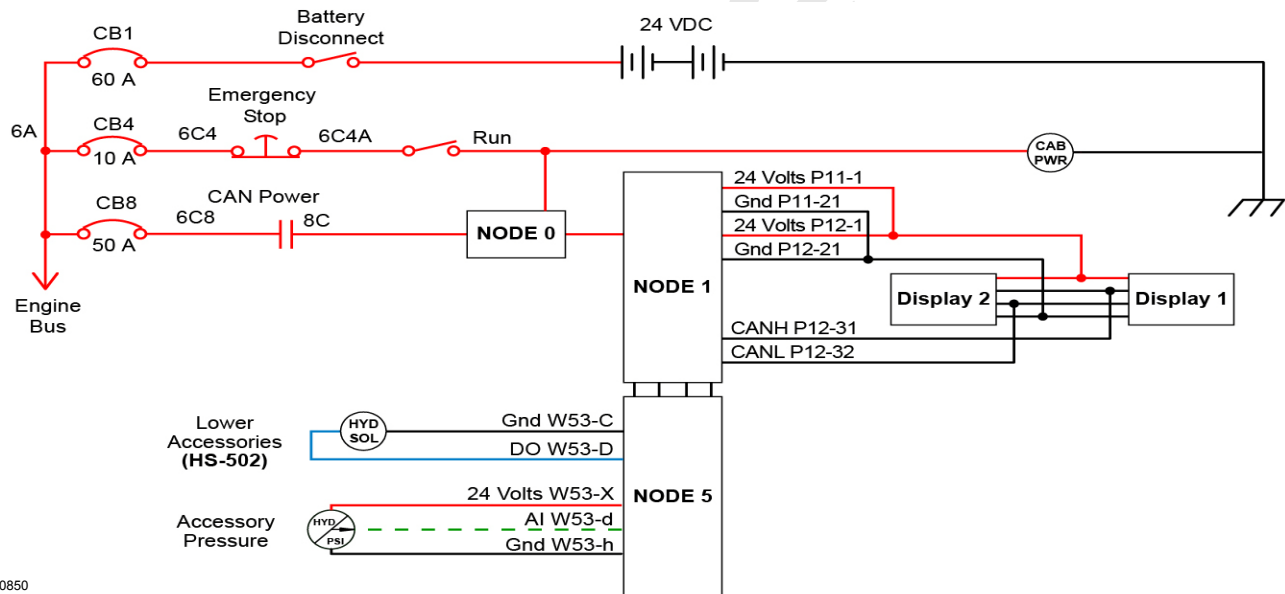

M100850

Figure 10-1. Carbody Electrical Diagram

Jack Cylinders

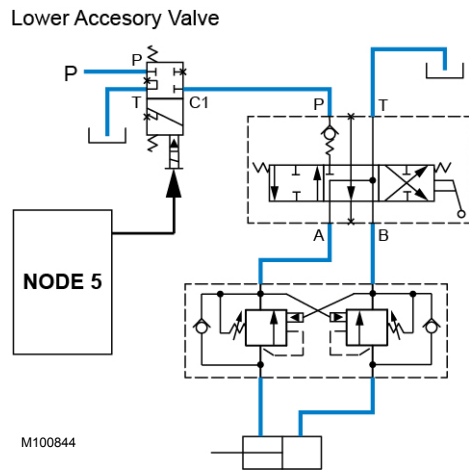

Figure 10-2. Jack Cylinder Control

Neutral

The valve spool is centered by the return springs in the neutral position. The center valve position is closed, so no fluid flows to the cylinder. The holding valves are also in the closed position, so no fluid can flow from the rod or barrel end of the cylinder if a load on the cylinder is producing pressure.

Extend

When the valve handle is moved to the extend position, the valve spool moves to the open position. Fluid flows from the pressure port, through the check valve, through the valve, and on to the holding valve. At the holding valve, fluid flows through the check valve at the barrel end of the valve and into the barrel end of the cylinder. At the same time, fluid opens the valve at the rod end of the cylinder. As fluid fills the barrel end of the cylinder, the rod extends and the movement forces fluid out of the rod end, through the open holding valve, through the open valve, and back to tank.

Retract

When the valve handle is moved to the retract position, the valve spool moves to the reversing position. Fluid flows from the pressure port, through the check valve, through the valve, and on to the holding valve. At the holding valve, fluid flows through the check valve at the rod end of the valve and into the rod end of the cylinder. At the same time, fluid opens the valve at the barrel end of the cylinder. As fluid fills the rod end of the cylinder, the rod retracts and the movement forces fluid out of the barrel end, through the open holding valve, through the open valve, and back to tank.

Pin Pullers

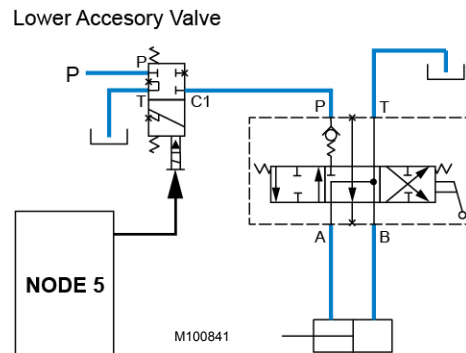

Figure 10-3. Car Body Pin Puller Control

Neutral

The valve spool is centered by the return springs in the neutral position. The center valve position is closed, so no fluid flows to the cylinder.

Extend

When the valve handle is moved to the extend position, the valve spool moves to the open position. Fluid flows from the pressure port, through the check valve, through the valve, and on to the cylinder. As fluid fills the barrel end of the cylinder, the rod extends and the movement forces fluid out of the rod end, through the open valve, and back to tank.

Retract

When the valve handle is moved to the retract position, the valve spool moves to the reverse position. Fluid flows from the pressure port, through the check valve, through the valve, and on to the cylinder. As fluid fills the rod end of the cylinder, the rod retracts and the movement forces fluid out of the barrel end, through the open valve, and back to tank.

ROTATING BED CYLINDERS

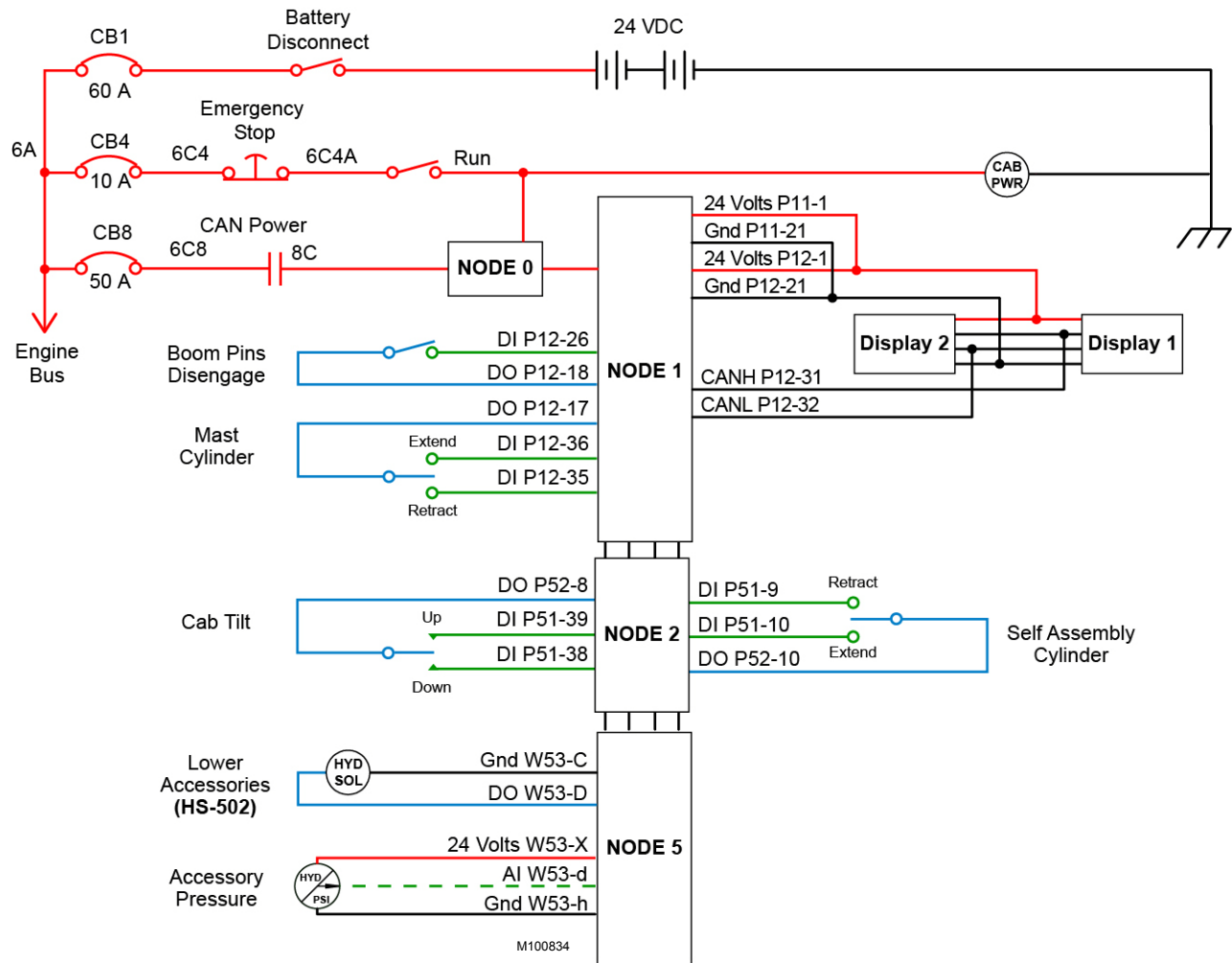

Figure 10-4. Rotating Bed Accessories Electrical Diagram—Part 1

Refer

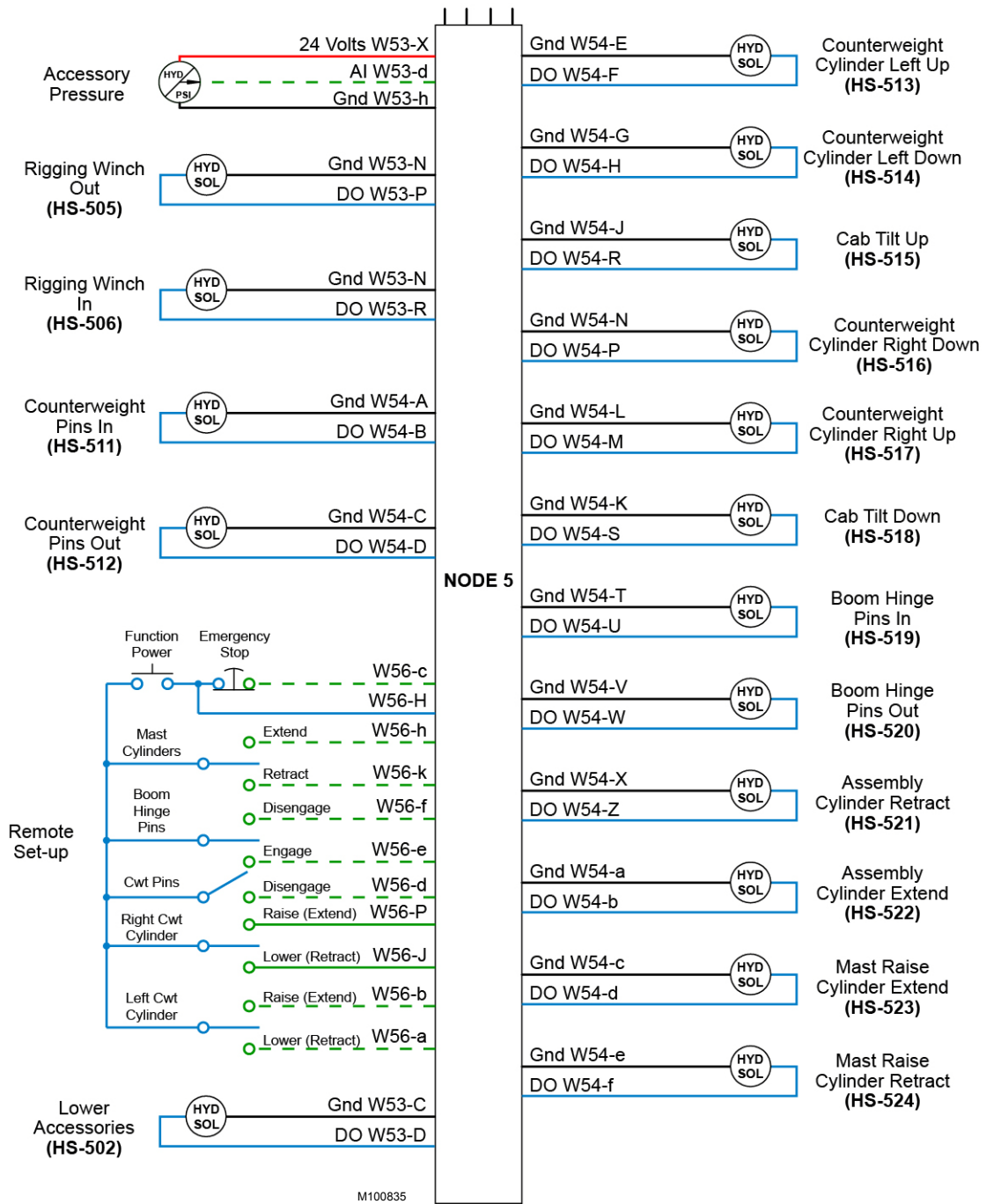

Figure 10-5. Rotating Bed Accessories Electrical Diagram—Part 2

Mast

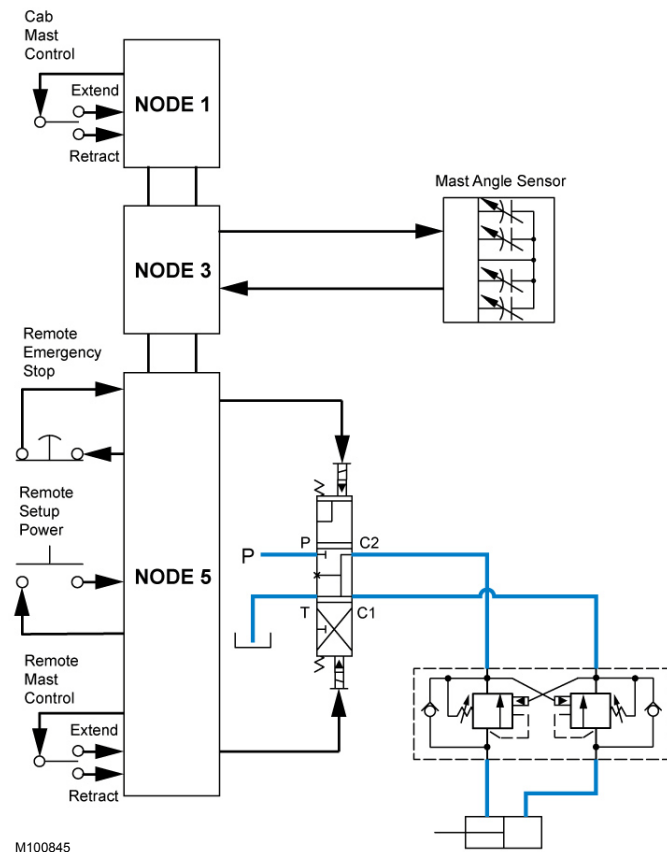

Figure 10-6. Mast Cylinder Control

Neutral

Node 1 sends 24Vdc to the mast cylinders extend/retract switch poles in the cab. Node 5 sends 24Vdc to the mast cylinder extend/retract switches in the remote set-up controller. The switches are momentary and normally open, so the corresponding node reads 0Vdc back when no switches are being pressed. Node 5 drives no solenoids in this state, so the valve spool is centered by the return springs in the neutral position. The center valve position is closed, so no fluid flows to the cylinder. The holding valves are also in the closed position, so no fluid can flow from the rod or barrel end of the cylinder if a load on the cylinder is producing pressure.

Raise

When either of the mast cylinders extend/retract switches are toggled to the extend position, the extend contact closes and sends the 24Vdc supply signal back to the corresponding node. Node 5 then sends a 24Vdc signal to the mast raise cylinder extend solenoid, energizing it.

The valve spool moves to the open position. Fluid flows from the pressure port, through the valve, and on to the holding valve. At the holding valve, fluid flows through the check valve at the barrel end of the valve and into the barrel end of the cylinder. At the same time, fluid opens the valve at the rod end of the cylinder. As fluid fills the barrel end of the cylinder, the rod extends and the movement forces fluid out of the rod end, through the open holding valve, through the open valve, and back to tank.

Lower

When either of the mast cylinders extend/retract switch is toggled to the retract position, the retract contact closes and sends the 24Vdc supply signal back to the corresponding node. Node 5 then sends a 24Vdc signal to the mast raise cylinder retract solenoid, energizing it.

The valve spool moves to the reversing position. Fluid flows from the pressure port, through the valve, and on to the holding valve. At the holding valve, fluid flows through the check valve at the rod end of the valve and into the rod end of the cylinder. At the same time, fluid opens the valve at the barrel end of the cylinder. As fluid fills the rod end of the cylinder, the rod retracts and the movement forces fluid out of the barrel end, through the open holding valve, through the open valve, and back to tank.

Assembly Cylinder (Optional)

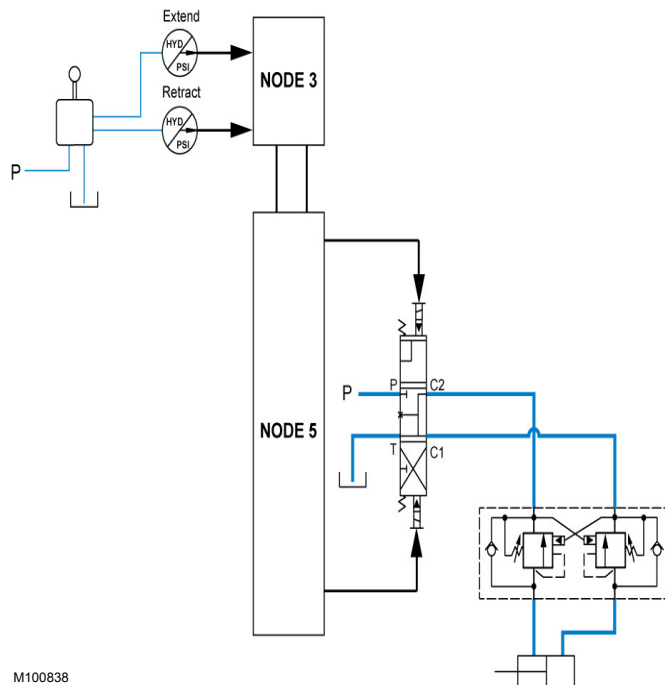

M100838

Figure 10-7. Assembly Cylinder Control

Neutral

While drum 3/4 handle is in the neutral position, node 3 receives no out-of-neutral threshold pressure signal from the drum 3/4 pilot pressure transducer. Node 5 drives no solenoids in this state, so the valve spool is centered by the return springs in the neutral position. The center valve position is closed, so no fluid flows to the cylinder. The holding valves are also in the closed position, so no fluid can flow from the rod or barrel end of the cylinder if a load on the cylinder is producing pressure.

Extend

When the drum 3/4 handle is pushed forward, node 3 receives an out-of-neutral threshold pressure signal from the

drum 3/4 pilot pressure transducer. Node 5 then sends a 24Vdc signal to the assembly cylinder extend solenoid, energizing it.

The valve spool moves to the open position. Fluid flows from the pressure port, through the valve, and on to the holding valve. At the holding valve, fluid flows through the check valve at the barrel end of the valve and into the barrel end of the cylinder. At the same time, fluid opens the valve at the rod end of the cylinder. As fluid fills the barrel end of the cylinder, the rod extends and the movement forces fluid out of the rod end, through the open holding valve, through the open valve, and back to tank.

The accessory system pump pressure command is proportional to the drum 3/4 handle position. This allows the assembly cylinder pressure to vary refining the extend or retract at a controlled speed.

Retract

When the drum 3/4 handle is pulled back, node 3 receives an out-of-neutral threshold pressure signal from the drum 3/4 pilot pressure transducer. Node 5 then sends a 24Vdc signal to assembly cylinder retract solenoid, energizing it.

The valve spool moves to the reversing position. Fluid flows from the pressure port, through the valve, and on to the holding valve. At the holding valve, fluid flows through the check valve at the rod end of the valve and into the rod end of the cylinder. At the same time, fluid opens the valve at the barrel end of the cylinder. As fluid fills the rod end of the cylinder, the rod retracts and the movement forces fluid out of the barrel end, through the open holding valve, through the open valve, and back to tank.

The accessory system pump pressure command is proportional to the drum 3/4 handle position. This allows the assembly cylinder pressure to vary refining the extend or retract at a controlled speed.

Boom Butt Pin Pullers

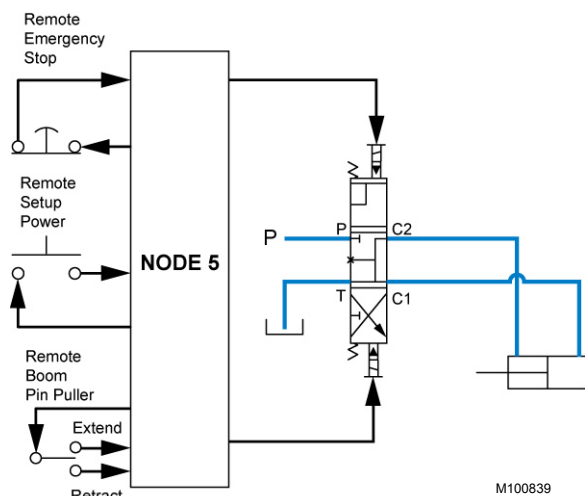

Figure 10-8. Boom Butt Pin Puller Control

Neutral

Node 1 sends 24Vdc to the boom pins disengage switch pole in cab. Node 5 sends 24Vdc to the boom hinge pins engage/disengage switch in the remote set up controller. The switches are momentary and normally open, so the corresponding node reads 0Vdc back when no switches are being pressed.

Engage

When the boom hinge pins engage/disengage switch in the remote set up controller is toggled to the engage position, the engage contact closes and sends the 24Vdc supply signal back to node 5. Node 5 then sends a 24Vdc signal to the boom hinge pins out solenoid, energizing it.

The valve spool moves to the open position. Fluid flows from the pressure port, through the valve, and on to the cylinder. As fluid fills the barrel end of the cylinder, the rod extends and the movement forces fluid out of the rod end, through the open holding valve, through the open valve, and back to tank.

Disengage

When the boom hinge pins engage/disengage switch in the remote set up controller or cab is toggled to the disengage position, the disengage contact closes and sends the 24Vdc supply signal back to the corresponding node. Node 5 then sends a 24Vdc signal to the boom hinge pins in solenoid, energizing it.

The valve spool moves to the reversing position. Fluid flows from the pressure port, through the valve, and on to the cylinder. As fluid fills the rod end of the cylinder, the rod retracts and the movement forces fluid out of the barrel end, through the open holding valve, through the open valve, and back to tank.

Counterweight Cylinders

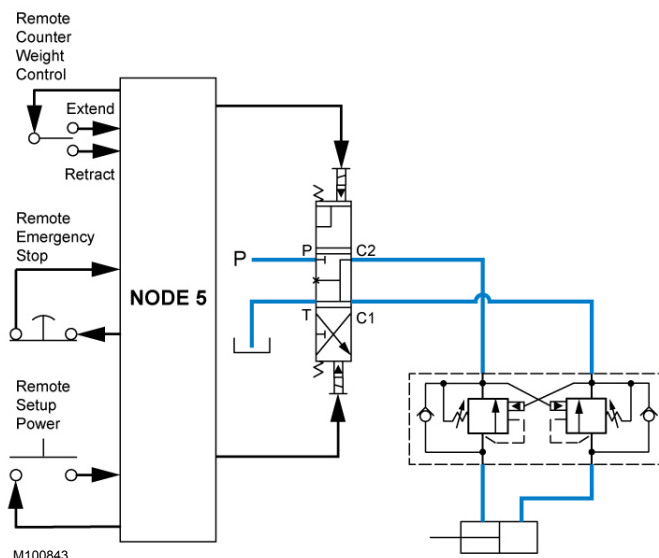

Figure 10-9. Counterweight Cylinder Control

Neutral

Node 5 sends 24Vdc to the left and right counterweight raise/lower switches in the remote set up controller. The switches are momentary and normally open, so the corresponding node reads 0Vdc back when no switches are being pressed. Node 5 drives no solenoids in this state, so the valve spool is centered by the return springs in the neutral position. The center valve position is closed, so no fluid flows to the cylinder. The holding valves are also in the closed position, so no fluid can flow from the rod or barrel end of the cylinder if a load on the cylinder is producing pressure.

Raise

When the left or right counterweight cylinder raise/lower switch is toggled to the raise position, the raise contact closes and sends the 24Vdc supply signal back to node 5. Node 5 then sends a 24Vdc signal to the left or right counterweight up solenoid, energizing it.

The valve spool moves to the open position. Fluid flows from the pressure port, through the valve, and on to the holding valve. At the holding valve, fluid flows through the check valve at the barrel end of the valve and into the barrel end of the cylinder. At the same time, fluid opens the valve at the rod end of the cylinder. As fluid fills the barrel end of the cylinder, the rod extends and the movement forces fluid out of the rod end, through the open holding valve, through the open valve, and back to tank.

Lower

When the left or right counterweight cylinder raise/lower switch is toggled to the lower position, the lower contact closes and sends the 24Vdc supply signal back to node 5.

Node 5 then sends a 24Vdc signal to the left or right counterweight down solenoid, energizing it.

The valve spool moves to the reversing position. Fluid flows from the pressure port, through the valve, and on to the holding valve. At the holding valve, fluid flows through the check valve at the rod end of the valve and into the rod end of the cylinder. At the same time, fluid opens the valve at the barrel end of the cylinder. As fluid fills the rod end of the cylinder, the rod retracts and the movement forces fluid out of the barrel end, through the open holding valve, through the open valve, and back to tank.

Counterweight Pin Pullers

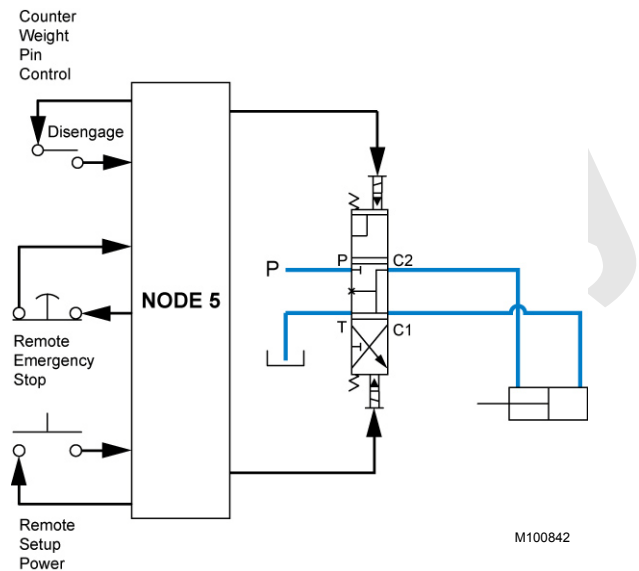

Figure 10-10. Counterweight Pin Puller Control

Neutral

Node 5 sends 24Vdc to the counterweight pins disengage switch pole in the remote setup. The switch is momentary and normally open, so node 5 reads back 0Vdc back when the switch is not being pressed. Node 5 then sends a 24Vdc signal to the counterweight pins in solenoid, energizing it.

The valve spool moves to the open position. Fluid flows from the pressure port, through the valve, and on to the cylinder. As fluid fills the barrel end of the cylinder, the rod extends and the movement forces fluid out of the rod end, through the open valve, and back to tank.

Disengage

When the counterweight pins disengage switch in the remote set up controller is toggled to the disengage position, the disengage contact closes and sends the 24Vdc supply signal back to the corresponding node. Node 5 then sends a 24Vdc signal to the counterweight pins out solenoid, energizing it.

The valve spool moves to the reversing position. Fluid flows from the pressure port, through the valve, and on to the cylinder. As fluid fills the rod end of the cylinder, the rod retracts and the movement forces fluid out of the barrel end, through the open holding valve, through the open valve, and back to tank.

Cab Tilt

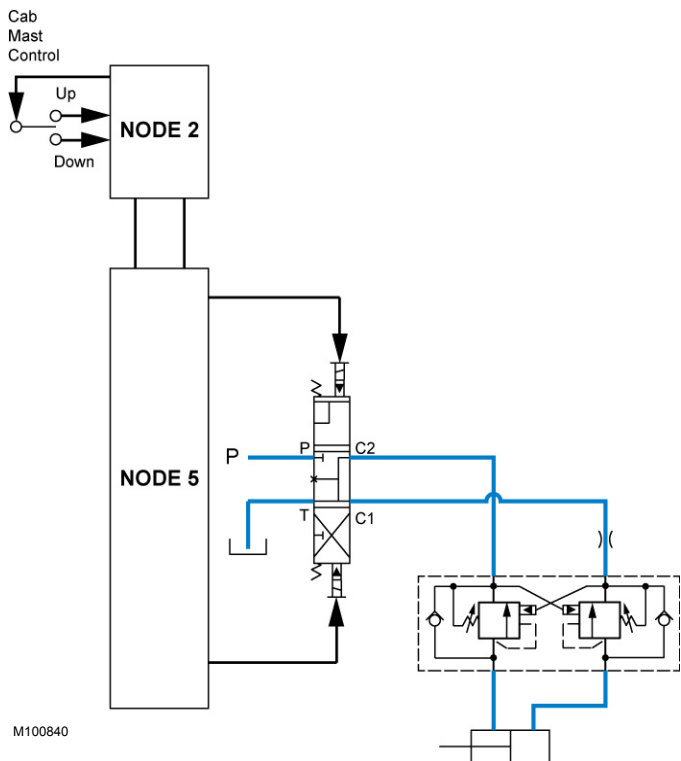

Figure 10-11. Cab Tilt Control

Neutral

Node 2 sends 24Vdc to the cab tilt up/down switch in the cab. The switch is momentary and normally open, so node 2 reads 0Vdc back when no switches are being pressed. Node 5 drives no solenoids in this state, so the valve spool is centered by the return springs in the neutral position. The center valve position is closed, so no fluid flows to the cylinder. The holding valves are also in the closed position,

so no fluid can flow from the rod or barrel end of the cylinder if a load on the cylinder is producing pressure.

Raise

When the cab tilt up/down switch is toggled to the up position, the up contact closes and sends the 24Vdc supply signal back to node 2. Node 5 then sends a 24Vdc signal to the cab tilt up solenoid, energizing it.

The valve spool moves to the open position. Fluid flows from the pressure port, through the valve, and on to the holding valve. At the holding valve, fluid flows through the check valve at the barrel end of the valve and into the barrel end of the cylinder. At the same time, fluid opens the valve at the rod end of the cylinder. As fluid fills the barrel end of the cylinder, the rod extends and the movement forces fluid out of the rod end, through the open holding valve, through the open valve, and back to tank.

Lower

When the cab tilt up/down switch is toggled to the down position, the down contact closes and sends the 24Vdc supply signal back to node 2. Node 5 then sends a 24Vdc signal to the cab tilt down, energizing it.

The valve spool moves to the reverse position. Fluid flows from the pressure port, through the valve, and on to the holding valve. At the holding valve, fluid flows through the check valve at the rod end of the valve and into the rod end of the cylinder. At the same time, fluid opens the valve at the barrel end of the cylinder. As fluid fills the rod end of the cylinder, the rod retracts and the movement forces fluid out of the barrel end, through the open holding valve, through the open valve, and back to tank.

THIS PAGE INTENTIONALLY LEFT BLANK

ALPHABETICAL INDEX

| | |
|--|------|
| Abbreviations | 1-4 |
| Accessory System Pressure | 10-1 |
| Air Cleaner | 7-6 |
| Automatic Boom Stop | 4-1 |
| Batteries | 7-1 |
| Battery Charger | 7-4 |
| Battery Disconnect Switch | 7-4 |
| Block-Up Limit Switch | 5-46 |
| Boom and Luffing Jib Angle Indicator | 4-6 |
| CAN Bus Control System | 3-1 |
| Carbody Theory of Operation | 10-1 |
| Checking and Replacing Electrical Components | 3-11 |
| Circuit Breakers | 3-8 |
| Continuous Innovation | 1-1 |
| Crawler Hand Pump and Jacking Cylinder | 8-8 |
| Crawler Preventative Maintenance | 8-7 |
| Crawler Tread Slack Adjustment | 8-7 |
| Crawler Tread Slack Measurement | 8-7 |
| Drum 1 Pawl | 5-29 |
| Drum 3 Pawl | 5-32 |
| Drum 4 Pawl | 5-31 |
| Drum Gearboxes | 5-19 |
| Drum Identification | 3-1 |
| Electrical Diagrams | 5-11 |
| Electrical Power Sequence | 3-1 |
| Engine Belt Routing | 7-10 |
| Engine Controls | 7-4 |
| Engine Enclosure | 7-10 |
| Engine Radiator | 7-11 |
| Engine Throttle Adjustment | 7-8 |
| Environmental Protection | 1-4 |
| Exhaust Aftertreatment System | 7-15 |
| Free Fall Brake | 5-51 |
| Hoist Theory of Operation | 5-1 |
| Hydraulic System Maintenance | 2-16 |
| Hydraulic System Overview | 2-1 |
| Hydraulic Tests and Calibrations | 2-31 |
| Identification and Location of Components | 1-5 |
| Lattice Section Inspection and Lacing Replacement | 4-15 |
| Load Block and Hook-and-Weight Ball Inspection | 5-60 |
| Lube and Coolant Product Guide | 9-1 |
| Lubrication | 9-1 |
| Manual Release of Swing Brake | 6-5 |
| Mast Angle Sending Unit | 4-7 |
| Minimum Bail Limit (Drum 1 and 2) | 5-43 |
| Minimum Bail Limit (Drum 3) | 5-37 |
| Minimum Bail Limits and Pressure Rollers (Drums 1 and 2) | 5-40 |
| Physical Boom Stop | 4-5 |
| Pressure Roller (Drum 1 and 2) | 5-45 |
| Rotating Bed Cylinders | 10-3 |
| Safe Maintenance Practices | 1-2 |
| Safety Messages | 1-1 |
| Sheave, Roller, and Drum Inspection (Weekly) | 5-57 |

Solenoid Valve Identification 3-7
Speed Sensor—Free Fall Drums 5-35
Speed Sensor—Hoist Motors 5-33
Strap Inspection and Maintenance 4-8
Swing Gearbox 6-6
Swing System Overview 6-1
Test Voltages 3-17
Travel Overview 8-1
Turntable Bearing Maintenance 8-5
Wire Rope Inspection and Replacement. 5-52

Reference Only

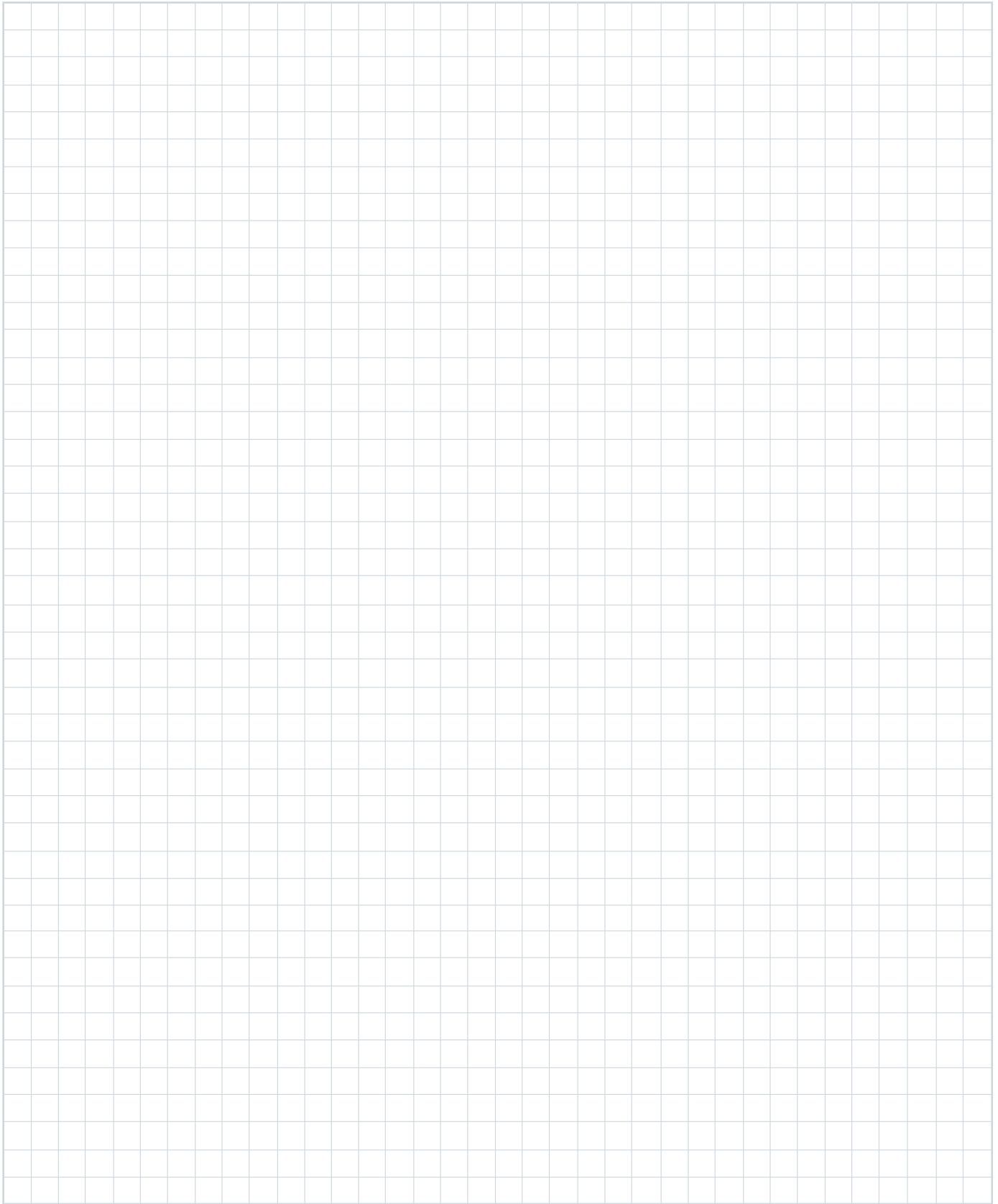

Grove

Manitowoc

National Crane

Potain



Grove

Manitowoc

National Crane

Potain

