

GHC85 Product Guide

ASME B30.5
Metric 75% and Imperial 75%



Features

- 80 t (85 USt)
- 11,0 – 42,0 m (36.1 – 137.8 ft) five-section boom
- 15 m (49.3 ft) offsettable bi-fold swingaway
- 100% pick and carry load charts at .6°, 1.5° and 4°
- Cummins B 6.7L Tier 4 final diesel engine
- Rear view, right side and hoist cameras
- High visibility cab with 20° tilt

GROVE GHC85

The GHC85 delivers heavy-duty lifting power and exceptional mid-range and maximum reach, with a boom length of 11,0 – 42,0 m (36.1 – 137.8 ft).

Features

> Strong telescopic boom

The GHC85 comes equipped with a robust five-section boom that allows for telescoping under load. The main boom 11,0 – 42,0 m (36.1 – 137.8 ft) of reach. This paired with the standard 15 m (49.3 ft) offsettable bi-fold swingaway extension provides a maximum tip height of 60,7 m (199 ft).

> Travel made easy

Transportation to the job site can easily be accomplished in 3-4 loads. Set up time is minimal thanks to the GHC85's quick self-assembly system for both the counterweight and side frames. Once assembled the strong undercarriage provides 100% pick and carry capability and work up to 4° of inclination. The hydraulically extendable tracks allow for three working gauges for maximum flexibility on the job.

> Asymmetrical track spans

Allowing asymmetrical track spans provides increased versatility on the jobsite. This makes it easier to work in congested jobsites with obstructions, and allows for increased capacities when comparing to the standard 360° load charts.



GHC85 benefits

More productive in more places on the jobsite

The GHC85 delivers unsurpassed maneuverability and versatility.

- Telescoping boom, plus heavy-duty crawler tracks for all-terrain productivity
- Superior gradeability
- High visibility cabs with up to 20° tilt
- Two-speed hydrostatic drive allows for skid steering and counter-rotation capability
- Compact design allows you to work in more places



Rugged durability to tackle all terrain

The GHC85 comes equipped with a durable, powerful crawler system.

- Hydraulically extendable and retractable crawlers
- Heavy-duty, 900 mm (36 in) triple bar, maintenance-free track shoes
- Cummins B 6.7L Tier 3 or Tier 4 final diesel engines power through terrain challenges
- Easy self-assembling crawlers



Easy transport to the jobsite and quick assembly

The GHC85 helps you spend less time on the truck and more time on the job.

- Transports to the jobsite in three to four loads
- Retracted gauge for transport width
- Self-assembly counterweight
- Undercarriage frame with jacks for easy self assembly of crawlers
- Excellent serviceability keeps you up and running



What you need, when you need it.

Get right to work with the right equipment — Manitowoc Finance gives you access to flexible, affordable financing you can use to seize profitable new opportunities as they arise.

Feel confident in your investment — rest easy with the assurance of the world's most advanced crane service and support network.

Contents

- Dimensions 5
- Load programs 7
- Transportation/assembly 8
- Working range/load charts - main boom metric 75% 10
- Working range/load charts - extensions metric 75% 14
- Working range/ load charts - main boom imperial 75% 15
- Working range/load charts - extensions imperial 75% 18
- Load handling 20
- Specifications 21

Dimensions

Transport dimensions and weights

Weight: approx. 90,9 t = 200,435 lb (two winches, with 15 m bi-fold jib, 50 t hook block, with 6 t carbody counterweight, with 28,3 t counterweight)

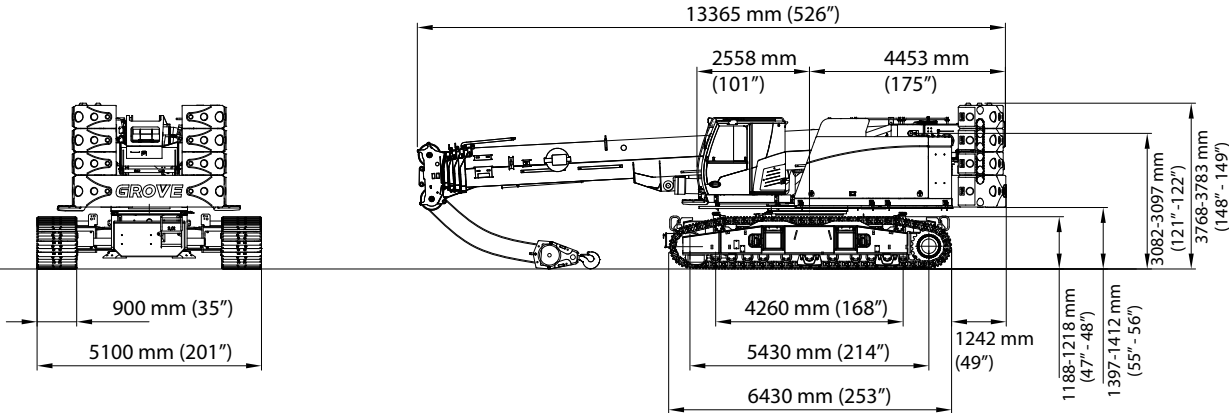

Weight: approx. 36,2 t = 79,780 lb (two winches, with 15 m bi-fold jib, 50t hook block, with walkway)

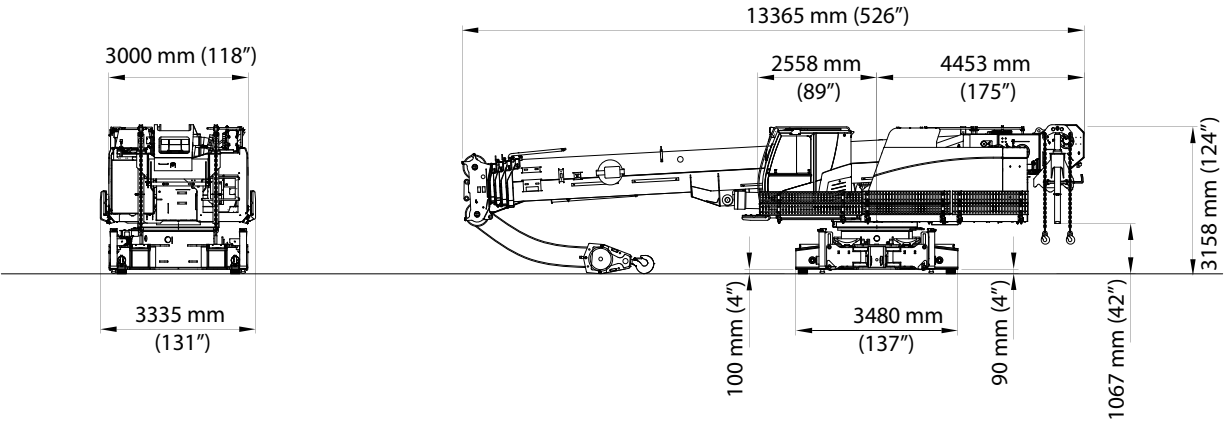

Weight: approx. 55,9t = 123,167 lb (two winches, with 15 m bi-fold jib, 50 t hook block, with walkway)

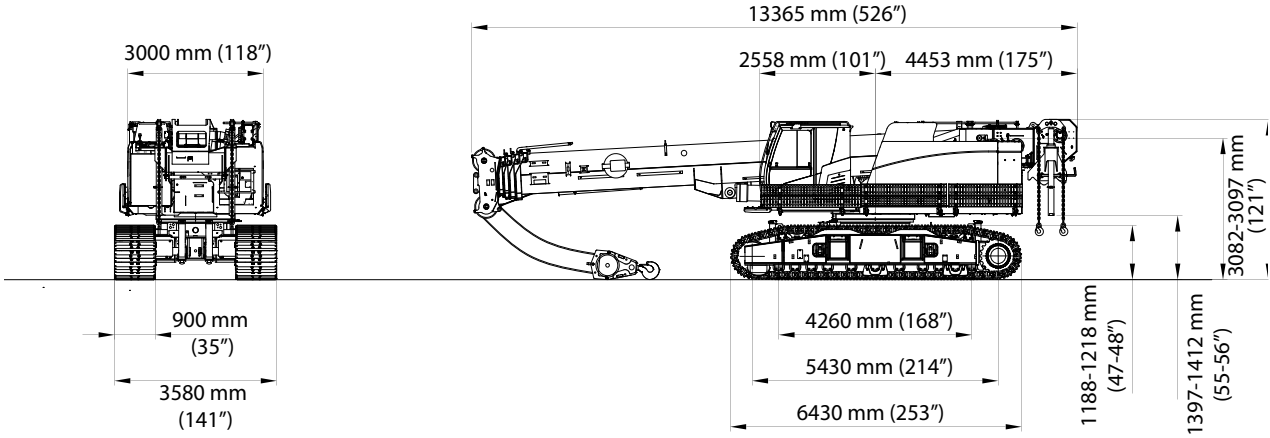











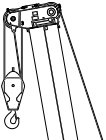
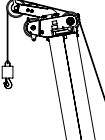























Dimensions











Transport dimensions and weights

	<p>Carbody counterweight x 2</p>	<p>3000 kg (6,614 lb)</p>
	<p>Crawler x 2</p>	<p>9 840 kg (21,693 lb) triple-bar 10 800 kg (23,810 lb) flat tracks</p>
	<p>Base plate for counterweight x 1</p>	<p>14 900 kg (32,849 lb)</p>
	<p>Counterweight x 4</p>	<p>2 250 kg (4,960 lb)</p>
	<p>Fly jib - 8 m (26.3 ft)</p>	<p>920 kg (2,028 lb)</p>
	<p>Fly jib extension - 7 m (23 ft)</p>	<p>300 kg (661 lb)</p>
	<p>Auxiliary jib</p>	<p>160 kg (353 lb)</p>
	<p>Heavy duty jib</p>	<p>700 kg (1,543 lb)</p>

Load programs

Working load programs

	Main boom			Auxiliary boom nose			Heavy Duty jib 3 m (10 ft)		
									
Undercarriage track width (centerline to centerline of crawlers)	 4,2 m (13.8 ft)	 3,4 m (11.3 ft)	 2,7 m (8.8 ft)	 4,2 m (13.8 ft)	 3,4 m (11.3 ft)	 2,7 m (8.8 ft)	 4,2 m (13.8 ft)	 3,4 m (11.3 ft)	 2,7 m (8.8 ft)
Counterweight									
 28,3 t (62,390 lb) + 6,0 t (13,230 lb)	360° 	360° 	—	360° 	360° 	—	360° 	360° 	—
 14,8 t (32,630 lb) + 6,0 t (13,230 lb)	360° 	360° 	—	360° 	360° 	—	360° 	360° 	—
 0,0 t + 0,0 t	360° 	360° 	360° 	360° 	360° 	360° 	360° 	360° 	—

	Boom extension 8 m (26.2 ft)			Boom extension with fly jib 15 m (49.2 ft)		
						
Undercarriage track width (centerline to centerline of crawlers)	 4,2 m (13.8 ft)	 3,4 m (11.3 ft)	 2,7 m (8.8 ft)	 4,2 m (13.8 ft)	 3,4 m (11.3 ft)	 2,7 m (8.8 ft)
Counterweight						
 28,3 t (62,390 lb) + 6,0 t (13,230 lb)	360° 	—	—	360° 	—	—

Note:

Safe working loads are available for 0.6°, 1.5° and 4° inclines.

*THIS CHART IS ONLY A GUIDE AND SHOULD NOT BE USED TO OPERATE THE CRANE.
The individual crane's load chart, operating instructions and other instructional plates must be read and understood prior to operating the crane.*

Transportation / assembly

1

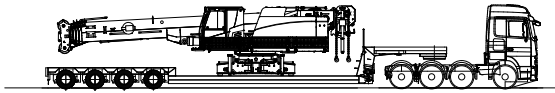

2

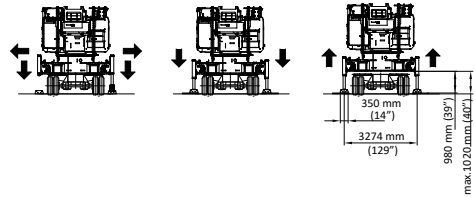

3

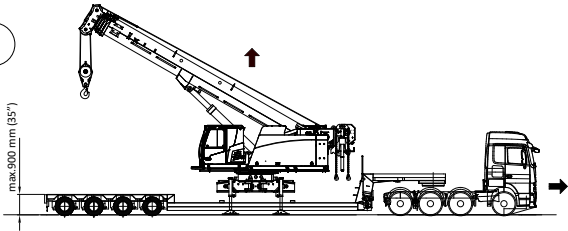

4

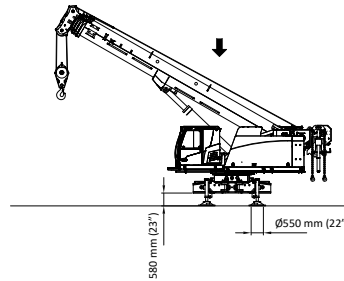

5

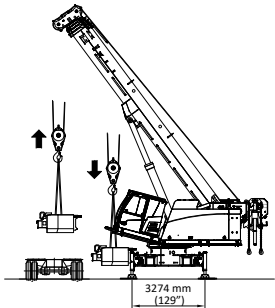

6

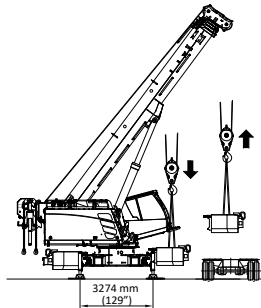

14

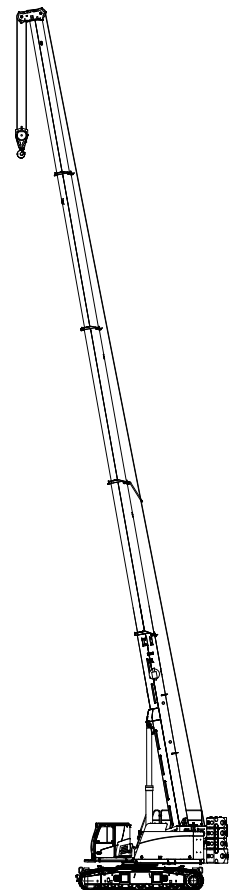

7

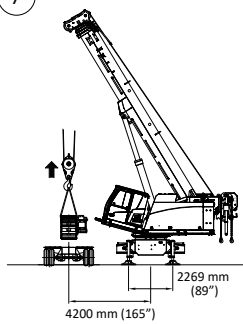

8

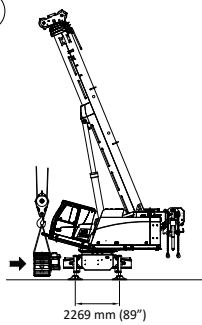

9

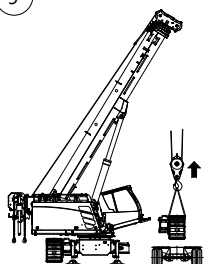

10

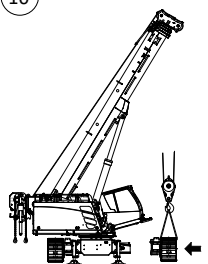

11

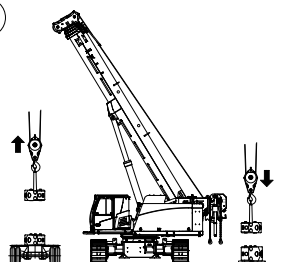

12

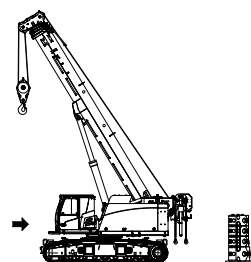

13

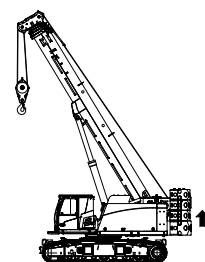

Transportation / assembly

1

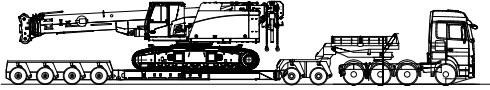

2

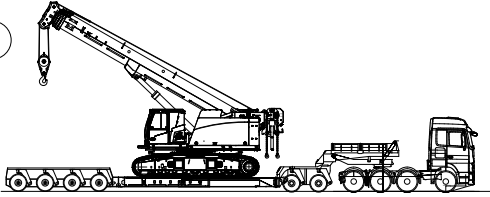

3

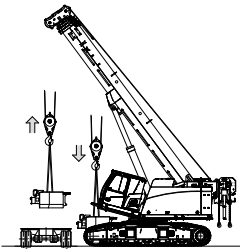

4

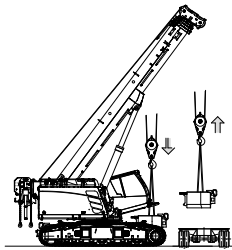

5

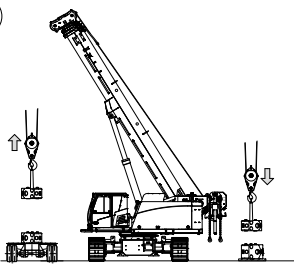

6

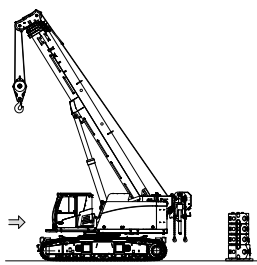

7

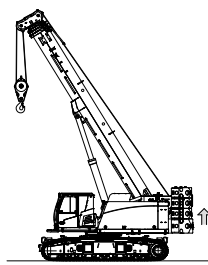

8

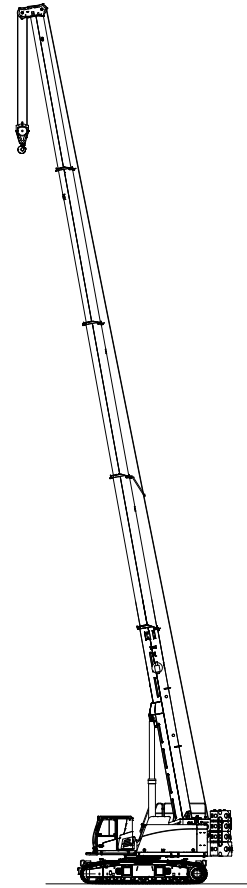

Working range

Main boom - metric 75%

Main boom

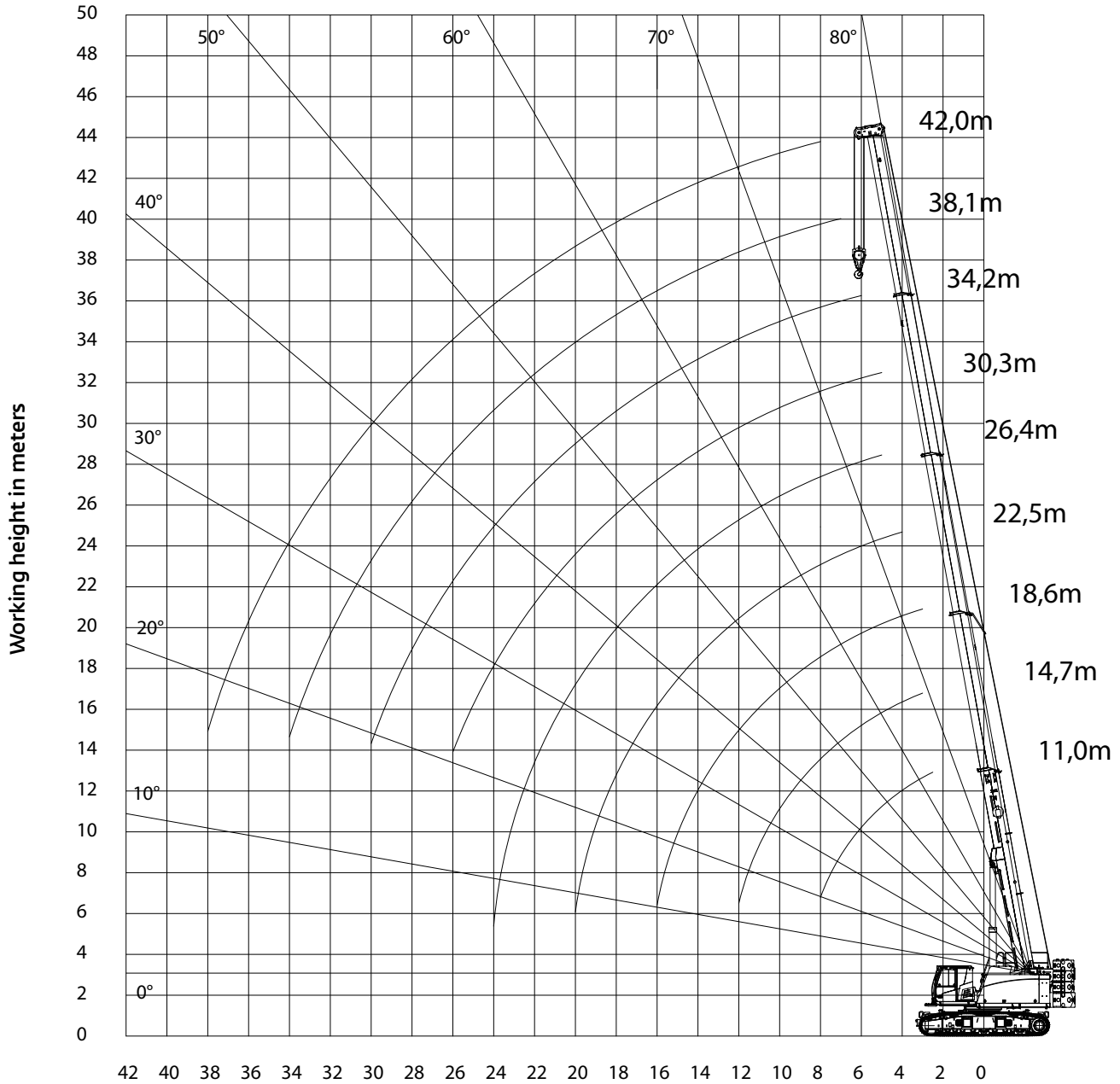

*THIS CHART IS ONLY A GUIDE AND SHOULD NOT BE USED TO OPERATE THE CRANE.
The individual crane's load chart, operating instructions and other instructional plates must be read and understood prior to operating the crane.*

Load chart

Main boom - metric 75%



42,0 m



28,3 t



100%



360°



0,6°



Kilograms

Radius [m]	Main boom length [m]								
	11.0	14.7	18.6	22.5	26.4	30.3	34.2	38.1	42.0
2.5	80.0								
3.0	72.5	50.0	40.8						
4.0	62.4	50.0	41.3	31.5					
5.0	54.7	50.0	41.0	31.4	26.9	20.0			
6.0	48.3	45.1	38.6	29.8	26.9	20.0	17.6		
7.0	41.7	40.1	34.7	29.4	25.9	20.0	17.7	15.6	
8.0	33.4	32.6	31.5	27.9	24.4	19.9	17.8	15.3	10.7
9.0		28.4	28.2	25.2	22.1	19.6	17.2	14.9	10.7
10.0		24.1	23.9	23.0	20.2	18.2	16.2	14.4	10.7
11.0		20.7	20.6	21.1	18.4	16.6	15.1	13.6	10.7
12.0		18.1	18.0	18.3	17.0	15.4	14.1	12.7	10.5
13.0			15.8	16.1	15.7	14.2	13.0	11.9	10.2
14.0			14.0	14.3	14.5	13.3	12.2	11.3	9.9
15.0			12.5	12.8	13.0	12.3	11.3	10.6	9.4
16.0			11.1	11.5	11.7	11.5	10.6	10.0	9.0
17.0				10.3	10.5	10.8	9.9	9.4	8.5
18.0				9.3	9.5	9.9	9.4	8.9	8.1
19.0				8.4	8.7	9.0	8.8	8.4	7.7
20.0				7.7	7.9	8.3	8.3	7.9	7.3
21.0					7.2	7.6	7.8	7.5	7.0
22.0					6.5	6.9	7.4	7.1	6.7
23.0					5.9	6.4	6.6	6.7	6.4
24.0					5.4	5.8	6.1	6.4	6.1
25.0						5.3	5.7	6.0	5.8
26.0						4.9	5.2	5.7	5.5
27.0							4.8	5.2	5.3
28.0							4.4	4.8	5.0
29.0							4.0	4.4	4.8
30.0							3.6	4.1	4.6
31.0								3.8	4.1
32.0								3.5	3.8
33.0								3.2	3.5
34.0								2.9	3.3
35.0									3.0
36.0									2.8
37.0									2.6
38.0									2.4

*THIS CHART IS ONLY A GUIDE AND SHOULD NOT BE USED TO OPERATE THE CRANE.
The individual crane's load chart, operating instructions and other instructional plates must be read and understood prior to operating the crane.*

Load chart

Main boom - metric 75%



42,0 m



28,2 t



100%



360°



1,5°



Kilograms

Radius [m]	Main boom length [m]								
	11.0	14.7	18.6	22.5	26.4	30.3	34.2	38.1	42.0
2.5	80.0								
3.0	72.5	50.0	40.6						
4.0	62.4	50.0	40.6	31.5					
5.0	54.7	50.0	39.8	31.4	26.0	19.9			
6.0	48.3	45.1	37.2	29.3	24.8	19.6	16.6		
7.0	41.7	40.1	34.7	28.5	23.7	19.3	16.1	14.8	
8.0	33.4	33.6	31.5	27.2	22.7	18.7	15.6	14.4	10.8
9.0		28.0	27.8	25.2	21.7	18.0	15.1	14.1	10.8
10.0		23.7	23.6	23.0	20.2	17.3	14.7	13.7	10.8
11.0		20.4	20.3	20.6	18.4	16.6	14.2	13.1	10.8
12.0		17.8	17.7	18.0	17.0	15.4	13.6	12.6	10.5
13.0			15.6	15.8	15.7	14.2	13.0	12.0	10.2
14.0			13.8	14.1	14.2	13.3	12.2	11.3	9.9
15.0			12.3	12.5	12.7	12.3	11.3	10.6	9.5
16.0			10.9	11.3	11.4	11.5	10.6	10.0	9.0
17.0				10.1	10.3	10.8	10.0	9.4	8.5
18.0				9.2	9.3	9.7	9.4	8.9	8.1
19.0				8.3	8.5	8.9	8.8	8.4	7.7
20.0				7.5	7.7	8.1	8.3	7.9	7.3
21.0					7.0	7.4	7.8	7.5	7.0
22.0					6.4	6.8	7.1	7.1	6.7
23.0					5.8	6.2	6.5	6.7	6.4
24.0					5.2	5.7	6.0	6.4	6.1
25.0						5.2	5.5	5.8	5.8
26.0						4.7	5.1	5.3	5.5
27.0							4.6	4.9	5.3
28.0							4.2	4.5	5.0
29.0							3.9	4.2	4.5
30.0							3.5	3.9	4.2
31.0								3.5	3.9
32.0								3.2	3.6
33.0								3.0	3.3
34.0									3.1
35.0									2.8
36.0									2.6
37.0									2.4
38.0									2.4

THIS CHART IS ONLY A GUIDE AND SHOULD NOT BE USED TO OPERATE THE CRANE.
The individual crane's load chart, operating instructions and other instructional plates must be read and understood prior to operating the crane.

Working range

Extensions - metric 75%

Main boom with extensions

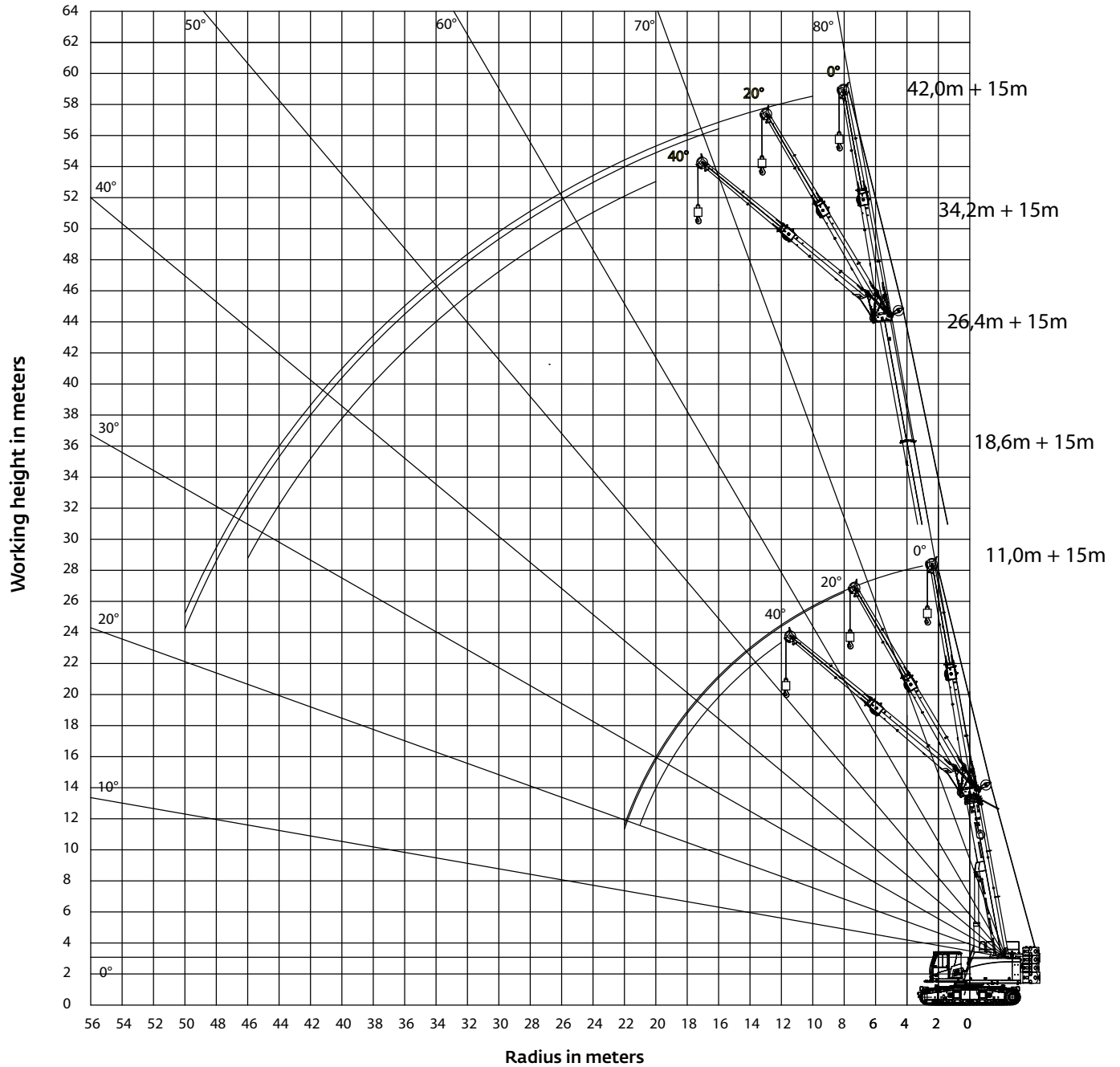

THIS CHART IS ONLY A GUIDE AND SHOULD NOT BE USED TO OPERATE THE CRANE.

The individual crane's load chart is only a guide and should not be used to operate the crane.

The individual crane's load chart, operating instructions and other instructional plates must be read and understood prior to operating the crane.

Load chart

Extensions - metric 75%



42,0 m



15 m



28,2 t



100%



360°



0.6°



Kilograms

Radius [m]	Main boom length [m]														
	11.0			18.6			26.4			34.2			42.0		
	0°	20°	40°	0°	20°	40°	0°	20°	40°	0°	20°	40°	0°	20°	40°
3.0	5.7														
4.0	5.6														
5.0	5.5			5.1											
6.0	5.4			5.0			5.0								
7.0	5.2			4.9			4.9								
8.0	5.0	4.1		4.7			4.8			4.3					
9.0	4.8	3.9		4.6			4.8			4.3					
10.0	4.5	3.7		4.4	3.9		4.7			4.2			2.8		
11.0	4.2	3.5		4.3	3.8		4.6			4.2			2.8		
12.0	4.0	3.4	2.9	4.1	3.6		4.5	3.7		4.1			2.8		
13.0	3.8	3.2	2.8	3.9	3.5		4.4	3.6		4.0			2.8		
14.0	3.6	3.1	2.7	3.7	3.4	2.8	4.3	3.5		4.0	3.5		2.8		
15.0	3.4	3.0	2.6	3.6	3.3	2.8	4.2	3.4		3.9	3.4		2.8		
16.0	3.2	2.9	2.6	3.4	3.2	2.7	4.1	3.3	2.7	3.8	3.3		2.8	3.0	
17.0	3.1	2.8	2.5	3.3	3.1	2.6	4.1	3.2	2.7	3.8	3.2		2.8	3.0	
18.0	2.9	2.7	2.5	3.2	3.0	2.6	4.0	3.1	2.6	3.7	3.2	2.6	2.8	2.9	
19.0	2.8	2.6	2.4	3.1	2.9	2.6	3.8	3.1	2.6	3.7	3.1	2.6	2.8	2.9	
20.0	2.7	2.5	2.4	3.0	2.8	2.5	3.7	3.0	2.6	3.6	3.0	2.6	2.8	2.9	2.5
21.0	2.6	2.5	2.4	2.9	2.7	2.5	3.6	2.9	2.5	3.5	3.0	2.5	2.8	2.8	2.4
22.0	2.5	2.4		2.8	2.7	2.4	3.4	2.8	2.5	3.5	2.9	2.5	2.8	2.8	2.4
23.0				2.7	2.6	2.4	3.3	2.8	2.5	3.4	2.8	2.5	2.8	2.7	2.4
24.0				2.6	2.6	2.4	3.2	2.7	2.4	3.3	2.8	2.4	2.8	2.7	2.3
25.0				2.5	2.5	2.4	3.1	2.7	2.4	3.3	2.7	2.4	2.8	2.6	2.3
26.0				2.5	2.5	2.4	3.0	2.6	2.4	3.2	2.7	2.4	2.8	2.6	2.3
27.0				2.4	2.4	2.4	3.0	2.6	2.4	3.1	2.6	2.4	2.8	2.6	2.3
28.0				2.3	2.4		2.9	2.5	2.3	3.1	2.6	2.3	2.7	2.5	2.2
29.0				2.3	2.4		2.8	2.5	2.3	3.0	2.5	2.3	2.7	2.5	2.2
30.0					2.4		2.7	2.5	2.3	2.9	2.5	2.3	2.7	2.4	2.2
31.0							2.7	2.4	2.3	2.8	2.5	2.3	2.6	2.4	2.2
32.0							2.6	2.4	2.3	2.8	2.4	2.3	2.6	2.4	2.2
33.0							2.5	2.4	2.3	2.7	2.4	2.2	2.6	2.3	2.2
34.0							2.5	2.3	2.3	2.7	2.4	2.2	2.5	2.3	2.1
35.0							2.4	2.3		2.6	2.3	2.2	2.5	2.3	2.1
36.0							2.4	2.3		2.6	2.3	2.2	2.5	2.3	2.1
37.0								2.3		2.5	2.3	2.2	2.4	2.2	2.1
38.0								2.3		2.5	2.3	2.2	2.4	2.2	2.1
39.0										2.4	2.2	2.2	2.3	2.2	2.1
40.0										2.1	2.2	2.2	2.2	2.2	2.1
41.0										1.9	2.2		2.1	2.1	2.1
42.0										1.8	2.0		2.0	2.1	2.1
43.0										1.6	1.8		2.0	2.0	2.0
44.0										1.5	1.6		1.9	1.9	2.0
45.0											1.4		1.6	1.9	1.9
46.0													1.5	1.8	1.8
47.0													1.2	1.4	
48.0													1.0	1.2	
49.0													0.8	0.9	
50.0													0.6	0.6	

THIS CHART IS ONLY A GUIDE AND SHOULD NOT BE USED TO OPERATE THE CRANE.

The individual crane's load chart, operating instructions and other instructional plates must be read and understood prior to operating the crane.

Working range

Main boom - imperial 75%

Main boom

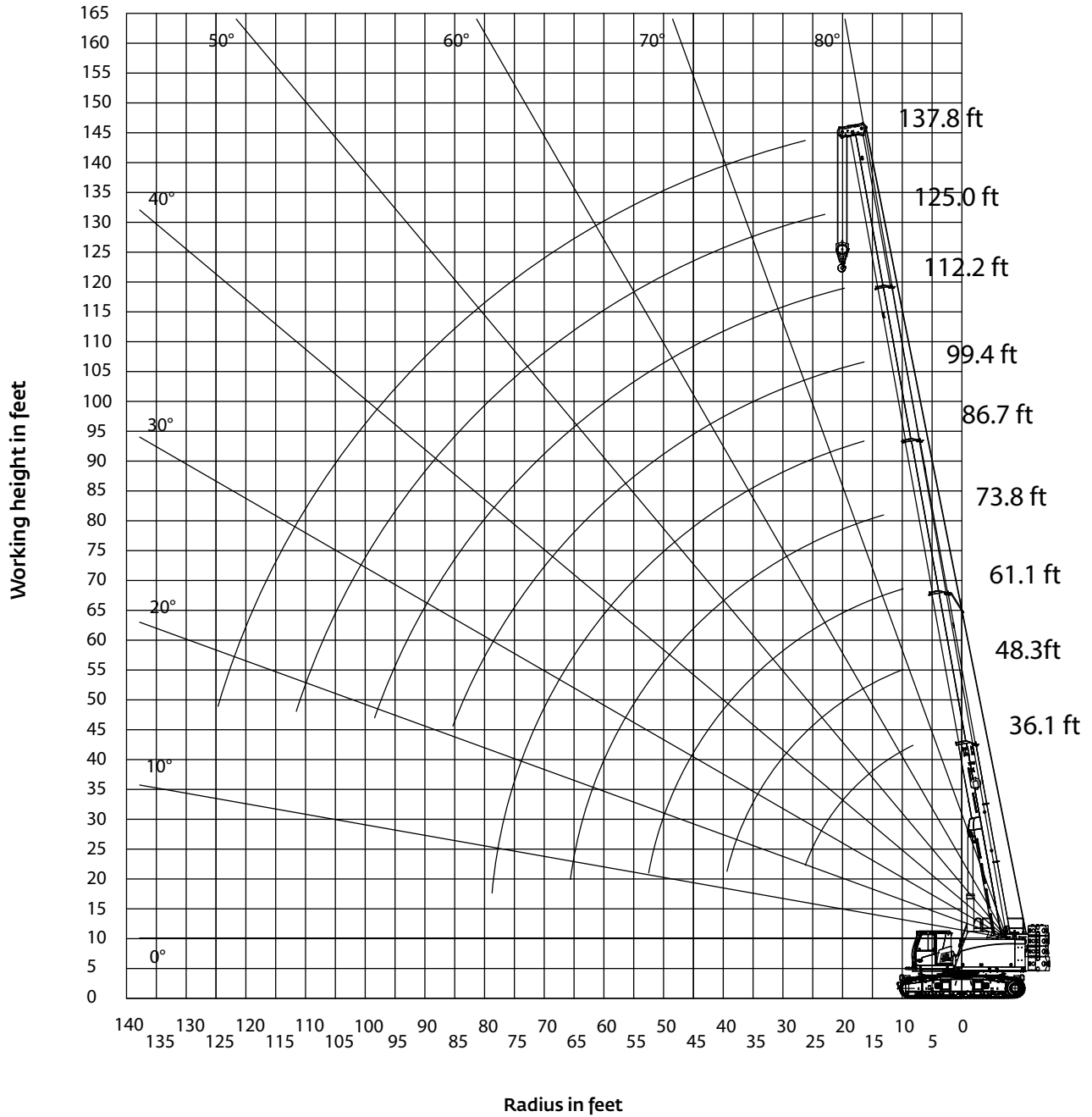

THIS CHART IS ONLY A GUIDE AND SHOULD NOT BE USED TO OPERATE THE CRANE.
 The individual crane's load chart, operating instructions and other instructional plates must be read and understood prior to operating the crane.

Load chart

Main boom - imperial 75%



137.8 ft



62.4 USt



100%



360°



0.6°



Pounds

Radius [ft]	Main boom length [ft]								
	35.9	48.2	61.0	73.8	86.6	99.4	112.2	125.0	137.8
10	158.8	110.2	90.0						
15	127.9	110.2	90.7	69.3					
20	105.1	98.4	84.3	65.5	59.2	44.1	38.8		
25	80.6	78.2	72.1	62.8	55.0	44.0	39.1	33.9	
30		61.2	60.8	54.8	48.1	42.8	37.6	32.7	23.6
35		48.2	47.9	47.8	41.9	37.8	34.1	30.5	23.6
40			38.7	39.4	36.8	33.5	30.6	27.7	23.1
45			32.0	32.6	32.7	29.9	27.4	25.3	22.1
50			26.8	27.5	27.9	26.7	24.6	23.1	20.6
55				23.4	23.8	24.1	22.3	21.1	19.0
60				20.0	20.4	21.3	20.3	19.3	17.6
65				17.2	17.7	18.5	18.5	17.7	16.3
70					15.4	16.2	16.9	16.2	15.2
75					13.3	14.2	14.9	14.9	14.2
80						12.4	13.1	13.7	13.2
85						10.8	11.5	12.7	12.3
90							10.1	11.1	11.4
95							8.8	9.8	10.6
100								8.7	9.6
105								7.6	8.4
110								6.7	7.5
115									6.6
120									5.9

*THIS CHART IS ONLY A GUIDE AND SHOULD NOT BE USED TO OPERATE THE CRANE.
The individual crane's load chart, operating instructions and other instructional plates must be read and understood prior to operating the crane.*

Load chart

Main boom - imperial 75%



137.8 ft



62.4 USt



100%



360°



1.5°



Pounds

Radius [ft]	Main boom length [m]								
	35.9	48.2	61.0	73.8	86.6	99.4	112.2	125.0	137.8
10	158.8	110.2	89.5						
15	127.9	110.2	88.5	69.3					
20	105.1	98.4	81.5	64.5	54.4	43.2	36.5		
25	80.6	79.5	72.0	61.1	50.8	41.7	34.8	32.1	
30		60.3	59.9	54.9	47.4	39.4	33.2	30.9	23.7
35		47.4	47.2	47.1	41.9	37.1	31.6	29.3	23.9
40			38.1	38.7	36.9	33.5	29.8	27.5	23.1
45			31.5	32.1	32.3	29.8	27.4	25.3	22.1
50			26.3	27.0	27.4	26.8	24.6	23.1	20.6
55				22.9	23.3	24.1	22.3	21.1	19.0
60				19.6	20.1	20.9	20.3	19.3	17.6
65				16.8	17.3	18.2	18.5	17.7	16.3
70					15.0	15.9	16.7	16.2	15.2
75					13.0	13.9	14.5	14.9	14.2
80						12.1	12.8	13.5	13.2
85						10.5	11.3	11.9	12.3
90							9.8	10.5	11.4
95							8.6	9.3	10.0
100								8.2	8.9
105								7.2	7.9
110									7.0
115									6.2
120									5.5

*THIS CHART IS ONLY A GUIDE AND SHOULD NOT BE USED TO OPERATE THE CRANE.
The individual crane's load chart, operating instructions and other instructional plates must be read and understood prior to operating the crane.*

Working range

Extensions - imperial 75%

Main boom with extensions

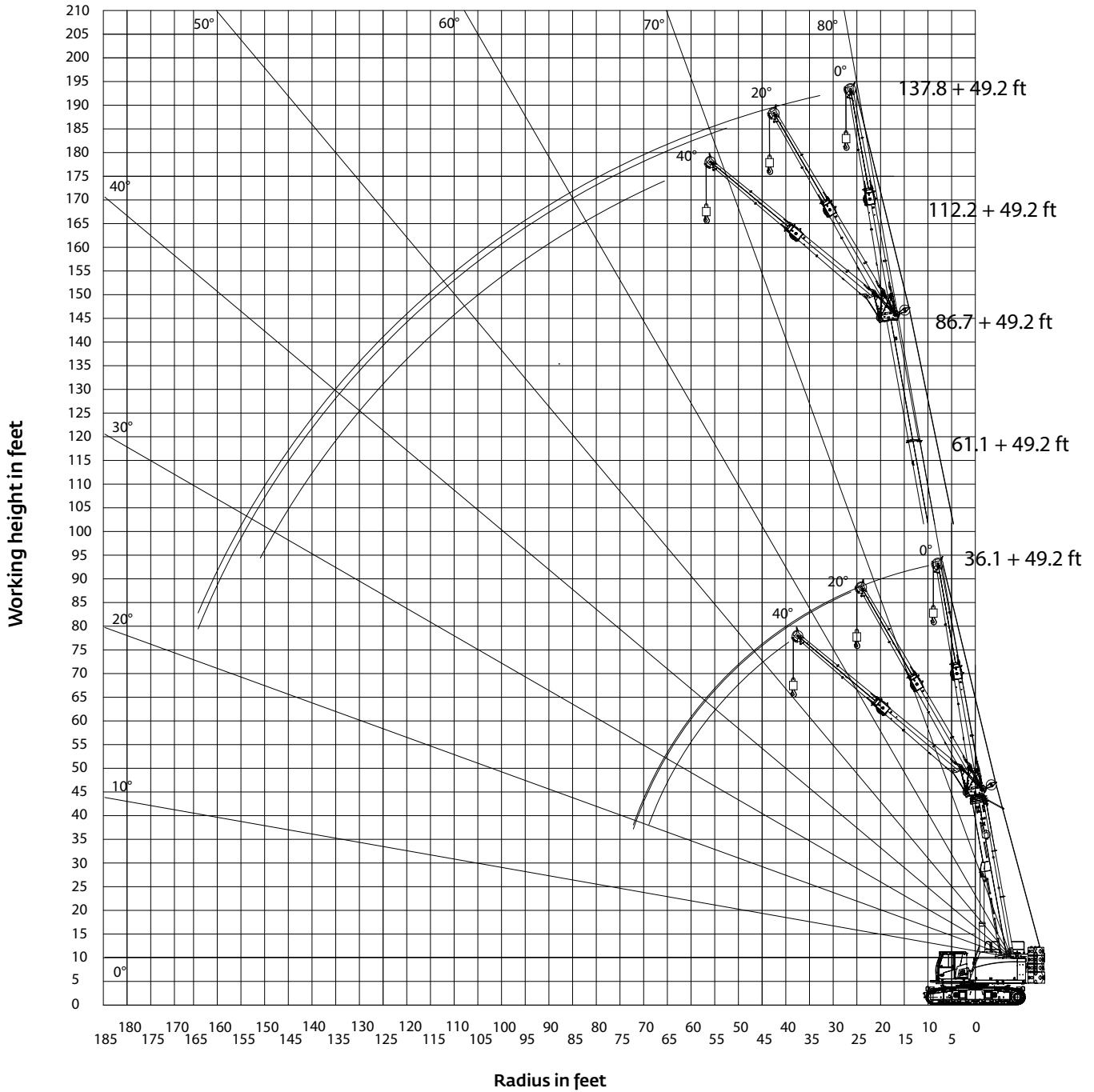

*THIS CHART IS ONLY A GUIDE AND SHOULD NOT BE USED TO OPERATE THE CRANE.
The individual crane's load chart, operating instructions and other instructional plates must be read and understood prior to operating the crane.*

Load chart

Extensions - imperial 75%



137.8 ft



49.2 ft



28.3 USt



100%



360°



0.6°



Pounds

Radius [ft]	Main boom length [ft]														
	35.9			61.0			86.6			112.2			137.8		
	0°	20°	40°	0°	20°	40°	0°	20°	40°	0°	20°	40°	0°	20°	40°
10	12.6														
15	12.3														
20	11.8			10.9			11.1								
25	11.2			10.5			10.8								
30	10.4	8.5		10.1			10.5			9.4					
35	9.5	7.9		9.5	8.4		10.2			9.2			6.2		
40	8.7	7.3	6.3	8.9	7.9		9.9	8.2		9.0			6.2		
45	8.0	6.9	6.0	8.3	7.5		9.6	7.8		8.8			6.2		
50	7.4	6.5	5.8	7.8	7.1	6.0	9.3	7.5		8.6	7.5		6.2		
55	6.9	6.2	5.6	7.4	6.8	5.9	9.0	7.1	6.0	8.4	7.2		6.2	6.5	
60	6.4	5.9	5.4	7.0	6.5	5.7	8.6	6.9	5.8	8.2	6.9	5.8	6.2	6.4	
65	6.0	5.6	5.4	6.6	6.2	5.6	8.2	6.6	5.7	8.0	6.7	5.6	6.2	6.3	
70	5.7	5.4		6.2	6.0	5.4	7.8	6.4	5.5	7.8	6.5	5.5	6.2	6.2	5.3
75				5.9	5.8	5.3	7.4	6.2	5.4	7.5	6.3	5.4	6.2	6.0	5.2
80				5.7	5.6	5.3	7.0	6.0	5.3	7.3	6.1	5.3	6.1	5.9	5.1
85				5.4	5.5	5.3	6.7	5.8	5.3	7.1	5.9	5.2	6.1	5.7	5.1
90				5.2	5.4		6.4	5.6	5.2	6.8	5.8	5.2	6.0	5.6	5.0
95				5.0	5.3		6.2	5.5	5.1	6.6	5.6	5.1	5.9	5.5	4.9
100							6.0	5.4	5.1	6.4	5.5	5.0	5.8	5.3	4.8
105							5.7	5.3	5.1	6.1	5.4	5.0	5.7	5.2	4.8
110							5.6	5.2	5.1	5.9	5.3	4.9	5.6	5.1	4.7
115							5.4	5.1		5.7	5.2	4.9	5.5	5.0	4.7
120								5.1		5.6	5.1	4.9	5.4	4.9	4.7
125										5.4	5.0	4.9	5.2	4.9	4.6
130										4.9	4.9	4.9	4.9	4.8	4.6
135										4.2	4.8		4.7	4.7	4.6
140										3.7	4.1		4.4	4.5	4.5
145											3.5		4.0	4.2	4.3
150													3.3	4.0	4.0
155													2.5	2.9	
160													1.9	2.0	

THIS CHART IS ONLY A GUIDE AND SHOULD NOT BE USED TO OPERATE THE CRANE.
The individual crane's load chart, operating instructions and other instructional plates must be read and understood prior to operating the crane.

Load handling

Weight reductions for load handling devices		
8 m - 15 m (26.2 ft - 49.2 ft) : Boom extension:		
	Without block or ball	With 200 kg (440 lb) headache ball
*8 m (26.2 ft) extension (erected)	1100 kg (2,419 lb)	1 460 kg (3,221 lb)
*15 m (49.2 ft) extension (erected)	1780 kg (3,878 lb)	2 256 kg (4,975 lb)
Hook blocks and Headache ball:		
80 t (88 USt), 5-sheave		1 000 kg+ (2,205 lb+)
50 t (55 USt), 3-sheave		675 kg+ (1,488 lb+)
20 t (22 USt), 1-sheave		325 kg+ (717 lb+)
10 t (11 USt) headache ball		200 kg+ (440 lb+)

*Reduction of main boom capacities
+Refer to rating plate for actual weight

When lifting over boom extension, deduct total weight of all load handling devices reeved over main boom nose from boom extension capacity.

NOTE: All load handling devices and boom attachments are considered part of the load and suitable allowances MUST BE MADE for their combined weights. Weights are for Grove furnished equipment.

Line pulls and reeving information			
Hoists	Cable specs	Permissible line pulls	Nominal cable length
Main and auxiliary	20 mm Verotop Rotation Resistant (non-rotating) Min. breaking strength 47 085 kg (85,795 lb)	7 200 kg* (15,876 lb*)	210 m (590 ft)

The approximate weight of Verotop 20 mm wire rope is 2,0 kg/m (1.3 lb/ft).

*With certain boom and hoist tackle combinations, the allowable line pull may be limited by hoist performance. Refer to Hoist Performance table for lift planning to ensure adequate hoist performance on drum rope layer required.

Hoist performance				
Wire rope layer	Hoist line pulls two-speed hoist		Drum rope capacity	
	Low available*	High available*	Layer	Total
1	9 585 kg (21,132 lb)	6 271 kg (13,826 lb)	39,4 m (129.3 ft)	39,4 m (129.3 ft)
2	8 886 kg (19,590 lb)	5 8148 kg (12,817 lb)	42,5 m (139.4 ft)	81,9 m (268.7 ft)
3	8 281 kg (18,257 lb)	5 418 kg (11,9459 lb)	45,6 m (49.6 ft)	127,5 m (418.3 ft)
4	7 754 kg (17,095 lb)	5 073 kg (11,184 lb)	48,7 m (159.8 ft)	176,2 m (578.1 ft)
5	7 290 kg (16,071 lb)	4 770 kg (10,515 lb)	51,8 m (169.9 ft)	228 m (748.0 ft)

*Max lifting capacity: Verotop 20 mm wire rope = 7 200 kg (15,876 lb)

Working area diagram

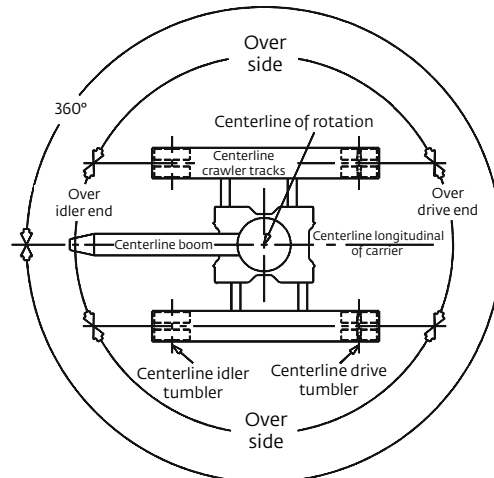

THIS CHART IS ONLY A GUIDE AND SHOULD NOT BE USED TO OPERATE THE CRANE.

The individual crane's load chart, operating instructions and other instructional plates must be read and understood prior to operating the crane.

Specifications

Upper carriage



Standard Boom

11,0 – 42,0 m (36.1 – 137.7 ft) five-section telescopic full power boom. Maximum tip height: 44 m (145 ft).



Boom extension

15 m (49.3 ft) offsettable bi-fold swingaway extension. Extension can be offset at 0°, 20° and 40°. Maximum tip height: 60,7 m (199 ft)



Heavy duty jib extension

3 m (10 ft) heavy duty jib extension that is offset at 10°. Stowable on left side of boom.



Boom nose

Five nylatron sheaves on heavy-duty roller bearings with removable rope guards. Quick reeve type boom nose. Equipped with removable auxiliary boom nose.



Boom elevation

One double-acting hydraulic cylinder with integral holding valves. Elevation: -3.0° to 80.5°.



Counterweight

Upper: 28 300 kg (62,390 lb) total (7 pieces)
Carbody: 6000 kg (13,230 lb) total (2 pieces)



Rated Capacity Limiter and anti-two block system

Graphical display of load moment and anti-two block system with audio-visual warning and control lever lockout. These systems provide electronic display of crane configuration, boom angle, length, radius, tip height, maximum permissible load, momentary load and warning of impending two-block condition. Includes advanced diagnostics system that increases the performance of the machine, simplifies and accelerates troubleshooting, and lowers operating costs. Equipped with event recorder.



Cab

Large-capacity operator's compartment that includes an air suspended operator's seat with lumbar support, heated seat, headrest, 3" safety belt, ergonomic control panels, load sensing electric dual axis joystick controls, travel pedals and levers, exceptional sound insulation, sliding door (includes sliding window), excellent all around visibility, tinted safety glass, front tiltable window, large skylight w/ sun protection, windshield and roof wiper/washer system, Bluetooth/AM/FM/USB/MP3 radio, climate control (A/C, heat, and defrost), fire extinguisher, and 20° tilt capability for improved overhead vision and ergonomic posture. Also equipped with a 7" monitor in cab for rear view, right side and hoist cameras.



Swing

Two-speed, compact planetary gear with axial piston hydraulic motor and integrated brake valves. Sealed, externally geared slewing ring that allows for 360° of continuous rotation. Electronically applied service brake operated via foot pedal. Spring applied, hydraulically released parking brake. Two position, hydraulically pinned house lock.

Swing speed: 0-2 rpm, variable



Hydraulic system

Load sensing / LUDV hydraulic system with hydraulic and pilot-controlled work functions, and load limit sensing control. Single variable-displacement piston pump with a three-section gear pump.

Maximum output: 500 lpm (132 gpm)

Maximum operating pressure: 330 bar (4786 psi)

1000 L (264 gal) steel hydraulic reservoir with sight level gauge.

High performance, 3 micron filtration system with water absorption contamination indicator for higher oil purity and extended oil service life.



Hoist

Two-speed hoists driven via an axial piston hydraulic motor with compact planetary gear. Spring-loaded disc brake. Grooved drum with drum rotation indicator for both hoists that is located in the joystick controls.

- Maximum hoist pull (first layer): 9 585 kg (21,132 lb)
- Maximum permissible single line pull: 7200 kg (15,876 lb)
- Maximum single line speed: 110 m/min (360 ft/min)
- Rope construction: 35 X 7 Rotation Resistant
- Rope diameter: 20 mm
- Rope length: 180 m (590 ft)



Engine (Tier 4)

Cummins B 6.7 L diesel, six cylinders, turbocharged with Cummins Diesel Oxidation (DOC) Catalyst and Selective Catalytic Reduction (SCR).

Meets USEPA Tier 4 final requirements.

186kW (249 bhp) at 2000 rpm.

Fuel requirements: Maximum of 15 ppm Sulphur content (ultra-low diesel fuel). DEF (diesel exhaust fluid) required for SCR (selective catalytic reduction).



Engine (Tier 3)

Cummins B 6,7 L diesel, six cylinders, turbocharged rated at 164 kW (220 bhp) at 2000 rpm.

Specifications



Fuel tank capacity

Diesel Fuel: 450 L (120 gal)
DEF (Diesel Exhaust Fluid): 45 L (12 gal)



Electrical system

24 volt with two 12-volt, maintenance-free batteries.
Includes battery disconnect switch.



Lights

Lighting package includes two halogen lights integrated into the front side of the cab roof and one LED headlight on the upper carriage, right side.



Cameras

Back-up, right-side and hoist cameras.

Lower carriage



Frame

Durable all steel welded construction with extendable side frame beams and hydraulic jacks for side frame installation and removal. Frame mounted hydraulic jacks also used for track extension and retraction.



Side frames

Four steel side frame beams that can be hydraulically extended or retracted via controls in the cab. 900 mm (36 in) triple bar maintenance-free track shoes.

- Retracted gauge: 2,7 m (8.8 ft)
- Intermediate gauge: 3,4 m (11.3 ft)
- Extended gauge: 4,2 m (13.8 ft)

**Note:* These widths are from centerline to centerline of crawlers.



Travel

Two-speed hydrostatic drive operated via lever/pedal controls in cab. Allows for excellent maneuverability with skid steering and counter-rotation. Both side frames are hydraulically driven through a two-stage hydraulic traction motor. Spring-loaded, hydraulically release multi-disk brake.

- Travel Speed: Max Low Range – 0,55 kmh (0.55 mph)
- Max High Range – 2,30 kmh (1.43 mph)
- Gradeability (theoretical): 57%

Operating weight

107 500 kg (237,000 lb) base machine configuration that includes 46,8 m (153.4 ft) boom, 15 m (49.3 ft) extension, 63 t (69 USt) hook block, 900 mm (36 in) triple bar crawlers, main and auxiliary hoist, 28 300 kg (62,391 lb) upper counterweight and carbody weight: 17 000 kg (37,478 lb).

Ground bearing pressure (no load): 0,93 kg/cm² (13.2 psi).

Miscellaneous standard equipment

- Central, easily accessible lubricating strip.
- Grated platform in front of cab, and foldable grated platforms on side of cab and both sides of the upper carriage. Foldable handrails included for upper carriage.
- Service friendly engine and hydraulic compartment with decoupled engine suspension, sound proofing and lighting.
- 63 t (69 USt) 3-sheave quick reeve hook block.
- External RCL light bar.
- Storage box attached to carbody counterweight.

*Optional equipment

- Basket: Yoke style, 72 in x 36 in (1829 mm x 914 mm) steel basket, gravity hung with cylinder brake lock (does not side stow). Includes quick-attach boom attachment. Basket capacities: 544,3 kg (1200 lb) main boom and 226,7 kg (500 lb) on boom extension.
- Radio remote control package.
- Cold weather packages up to -40° C / 40° F.
- Maintenance-free flat track shoes.
- Polyurethane clamp-on track pads.
- Two additional LED lights mounted on base boom
- Wind speed indicator (hardwired) displayed thru RCL.
- Work area definition system.
- Swing barrier protection. Provides a swing perimeter when used with caution tape.
- Pinion lubrication for slewing gear with lubrication pump, operated from cab, with special lubricant.
- CraneStar asset management system.

Notes

The Manitowoc Company, Inc.

Regional headquarters

Americas

Milwaukee, Wisconsin, USA
Tel: +1 414 760 4600

Shady Grove, Pennsylvania, USA
Tel: +1 717 597 8121

Europe and Africa

Dardilly, France - TOWERS
Tel: +33 (0) 4 72 18 20 20

Wilhelmshaven, Germany - MOBILE
Tel: +49 (0) 4421 294 0

APAC

Shanghai, China
Tel: +86 21 6457 0066

Singapore
Tel: +65 6264 1188

Middle East and India

Dubai, UAE
Tel: +971 4 8862677

This document is non-contractual. Constant improvement and engineering progress make it necessary that we reserve the right to make specification, equipment, and price changes without notice. Illustrations shown may include optional equipment and accessories and may not include all standard equipment.

