

SHUTTLELIFT®

SCD25

Product Guide

ASME B30.5 Imperial 85%



25 USt
(22 t)



71 ft
(21,6 m)



45,631 lbs
(20 698kg)



95 ft
(28,9 m)

SHUTTLELIFT SCD25

FEATURES

The SCD25 provides best-in-class reach combined with flexibility to adapt to nearly any jobsite. The four-position pivoting boom head allows for low headroom clearance while the out and down outriggers can be setup in multiple modes, depending on your jobsite requirements.

A 17 ft (5,1 m) swingaway extension added to the 71 ft (21,6 m) main boom provides an impressive 95 ft (28,9 m) tip height. Max capacity with main boom and extension is 7,500 lb (3402 kg).



Pivoting Boom Nose

Ideal for operating in confined spaces, the four-position mechanically offset (0°, 30°, 60° and 80°) pivoting boom nose lowers boom nose head height by 2 ft (0,6 m). Negative pivoting of 15° and 30° allows boom extension offset capability. The offset increases ground clearance for transporting a large load through a low clearance entrance/exit.

Available Options

- Convenience package includes pintle hitches and light grilles
- Lighting package includes amber strobe light and boom-mounted work lights
- Below-deck winch
- Air-conditioning
- RCL with Work Area Definition system

Operator Cab

Simple operator cab features hydraulic joystick controls, tilt steering wheel and easy-to-set up graphic RCL system. Also features 12 volt DC charging port, cup holder and comfortable suspension seat. Optional enclosed cab features split door design for additional comfort.



CUSTOMIZED OPTIONS

Standard options may not always meet the job requirements. Consult your local dealer for a Lift Solution quote for customized options, such as:

- Non-marking tires
- Oil cooler
- Barge charts
- External light bar
- Spark arrestor

Simple Tier 4 Final emissions

The aftertreatment system has been strategically placed behind the cab maintaining a clear right-hand space on the deck allowing long materials to be easily transported on the machine. Loads can be carried on the front deck, side deck, or hook. The diesel exhaust fluid (DEF) tank is easily accessed at the rear of the machine.



The world's most advanced crane service and support network

WORLDWIDE SUPPORT NETWORK

Manitowoc's customer service extends beyond any borders. Our locations span the globe, covering five continents. No matter where the job takes you, you have a business partner nearby.



PARTS

Locating the correct part quickly is vital to managing your operations. With Manitowoc Customer Support, the parts you need are just a phone call or click away.

LIFT SOLUTIONS

The Manitowoc Crane Lift Solutions Team is dedicated to helping customers with unique and customized applications for their Manitowoc cranes, regardless of product line.

TRAINING

Manitowoc Training Centers offer courses for operators and technicians across the globe to provide in-depth instruction on crane operation, maintenance, and troubleshooting procedures.

EnCORE

Manitowoc's EnCORE program maximizes your investment by rebuilding or repairing your crane to extend its life significantly. EnCORE also includes remanufactured parts.



MANITOWOC FINANCE

Manitowoc Finance gets you in the field with the right equipment by giving you access to flexible, affordable financing. With Manitowoc Finance, equipment can be acquired with virtually no cash outlay, and unlike traditional lending, our financial products don't affect bank lines of credit. Your capital resources remain intact for times when you need ready access to cash.

Competitive rates with flexible financing options and payment schedules put you in control.

Did you know? Manitowoc Finance can finance **used** Manitowoc cranes. You can also **trade-in** your used fleet for upgrade and get financed by Manitowoc Finance.



SCS 25

4x4



CONTENTS

8

Dimensions and Weights

10

Working Range and Load Charts

14

Transportation and lifting data

15

Load Handling

17

Specifications

19

Symbols Glossary

DIMENSIONS AND WEIGHTS

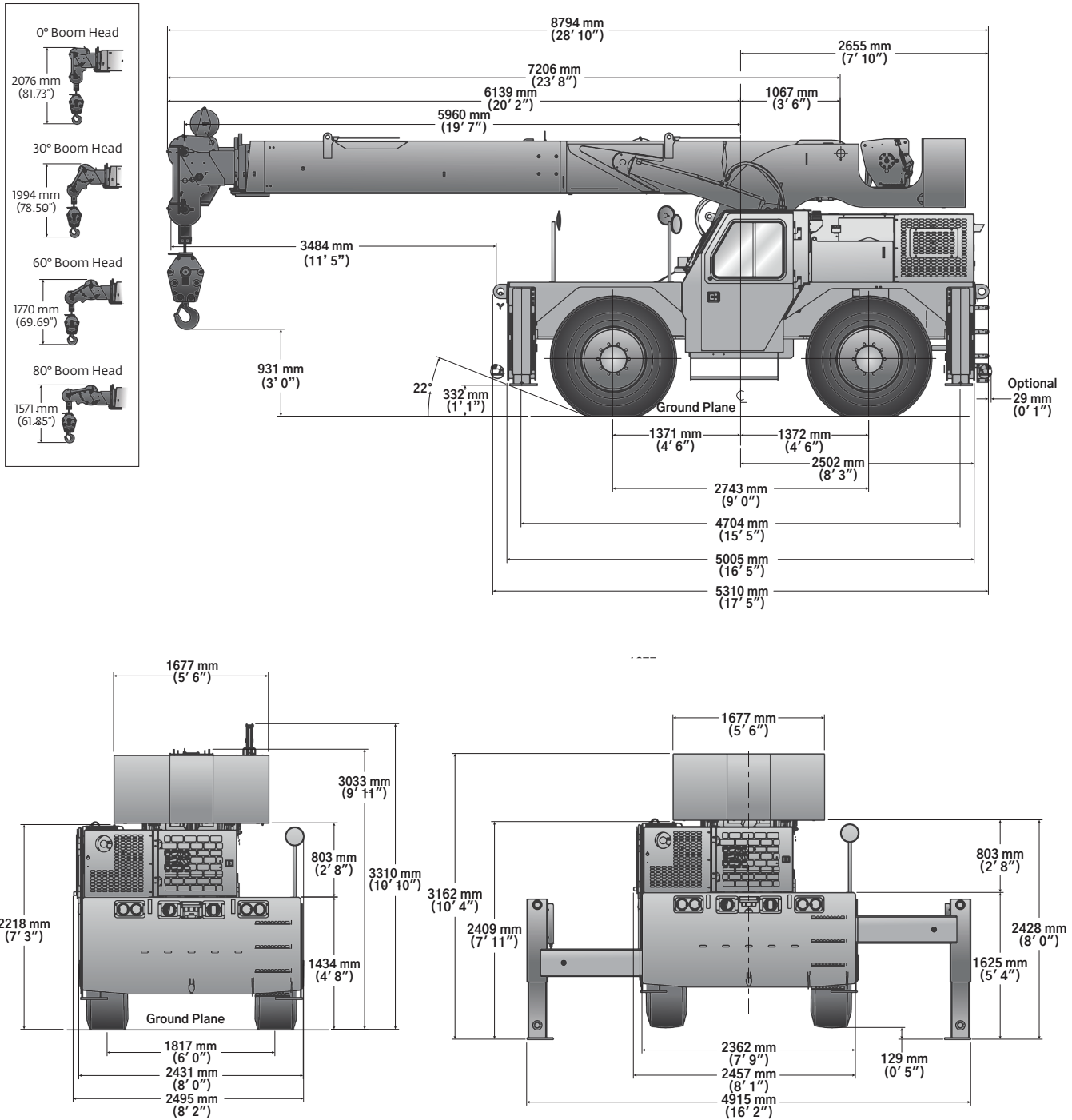

DIMENSIONS AND WEIGHTS

| Tire size | A | B | C | D | E | A | B | C | D | E |
|-----------|--------------------------|-----------------------|-----------------------|-----------------------|-----------------------|---------------------------|-----------------------|-----------------------|-----------------------|----------------------|
| 17.5 x 25 | 8593 mm (338.3 in) | 6178 mm (243.2 in) | 5556 mm (218.7 in) | 5337 mm (210.1 in) | 3813 mm (150.1 in) | 7062 mm (278.0 in) | 4828 mm (190.1 in) | 4454 mm (175.4 in) | 4109 mm (161.8 in) | 2422 mm (95.3 in) |
| | Two-wheel steer (radius) | | | | | Four-wheel steer (radius) | | | | |

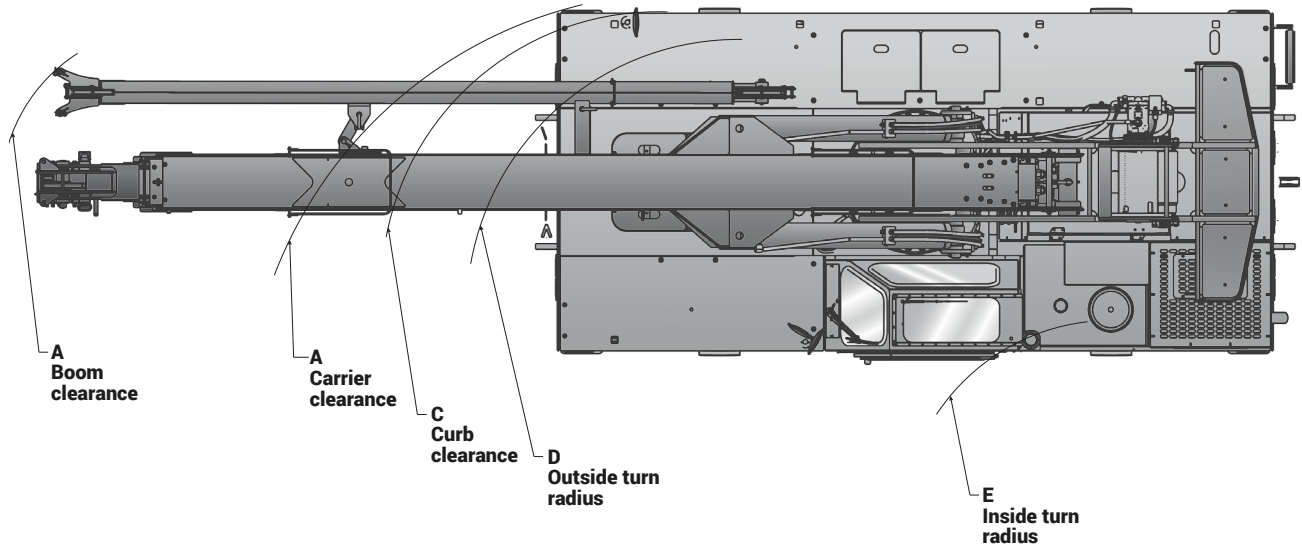

| Weights | GVW | | Front | | Rear | |
|---|--------|--------|--------|--------|--------|--------|
| | kg | lb | kg | lb | kg | lb |
| Basic machine: including 21,6 m (71.0 ft) main boom, hoist with 119,0 m (390 ft) of wire rope, 22,6 t (25 USt) hook block, counterweight, Tier 4 engine, and driver. | 20 623 | 45,465 | 10 115 | 22,299 | 10 508 | 23,166 |
| Add: 17 ft (5,1 m) fixed swingaway extension and extension carrier brackets and downhaul weight. | 255 | 563 | 458 | 1010 | -203 | -447 |
| Crane Weight | 20 878 | 46,028 | 10 573 | 23,309 | 10 305 | 22,719 |
| Basic machine: including 71.0 ft (21,6 m) main boom, main hoist with 390 ft (119,0 m) of wire rope, 25 USt (22,6 t) hook block, full counterweight, Tier 4 engine, and driver. | 20 623 | 45,465 | 10 115 | 22,299 | 10 508 | 23,166 |
| Add: Enclosed cab with heater and defroster. | 106 | 233 | 47 | 104 | 59 | 129 |
| Crane Weight | 20 729 | 45,698 | 10 162 | 22,402 | 10 567 | 23,296 |

WORKING RANGE

Imperial 85%

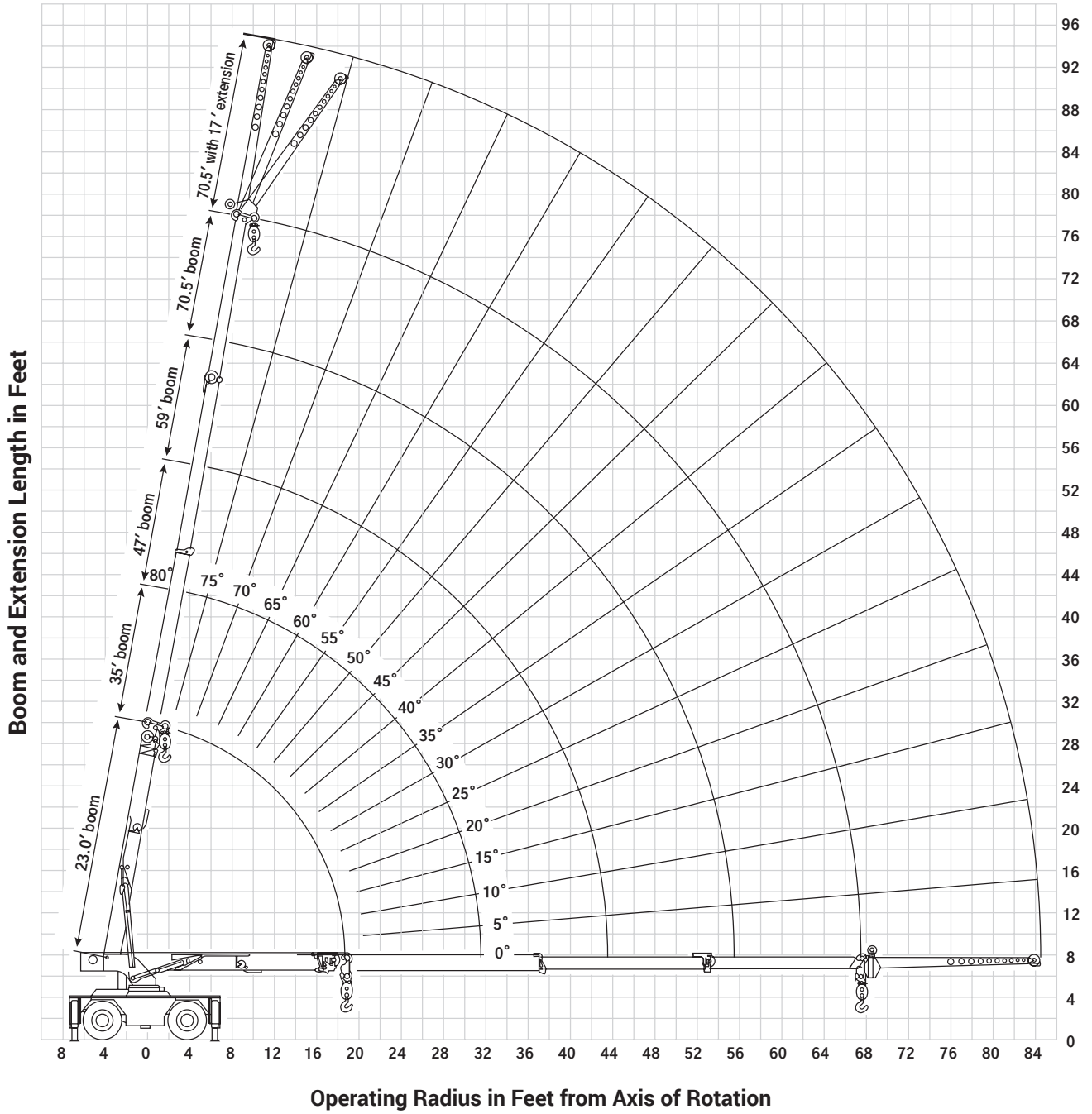

THIS CHART IS ONLY A GUIDE AND SHOULD NOT BE USED TO OPERATE THE CRANE.
The individual crane's load chart, operating instructions and other instructional plates must be read and understood prior to operating the crane

LOAD CHART

Imperial 85%

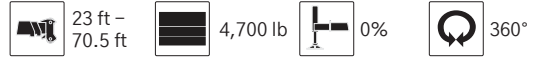
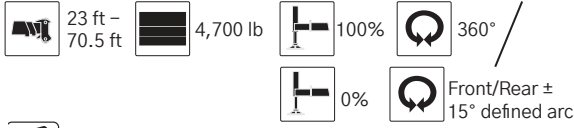

Pounds

| Feet | 23 | 35 | 47 | 59 | 70.5 |
|------|---------------|---------------|---------------|---------------|---------------|
| 8.5 | 50,000 (64.5) | 34,300 (73.5) | 33,600 (78.5) | | |
| 10 | 38,750 (60) | 34,500 (71) | 33,000 (76.5) | 27,800 (80) | |
| 12 | 34,850 (54) | 31,400 (67) | 29,250 (74) | 25,900 (78) | |
| 14 | 31,250 (47) | 28,450 (63.5) | 26,350 (71) | 24,100 (76) | 18,200 (79) |
| 16 | 26,700 (39) | 26,050 (59.5) | 24,000 (68.5) | 22,400 (74) | 16,750 (77.5) |
| 18 | 23,150 (29) | 23,500 (55.5) | 22,100 (66) | 20,750 (72) | 15,500 (75.5) |
| 19.5 | 21,000 (0) | 21,350 (52) | 20,900 (63.5) | 19,550 (70.5) | 14,650 (74.5) |
| 22 | | 18,450 (46) | 18,600 (60) | 17,850 (67.5) | 13,400 (72) |
| 24 | | 16,650 (41) | 16,750 (57) | 16,300 (65) | 12,500 (70.5) |
| 26 | | 14,600 (36) | 14,850 (54) | 14,200 (63) | 11,750 (68.5) |
| 28 | | 12,750 (29) | 13,050 (51) | 13,150 (60.5) | 11,050 (67) |
| 30 | | 11,250 (20) | 11,600 (47.5) | 11,700 (58.5) | 9,800 (65.5) |
| 31.5 | | 10,300 (0) | 10,650 (45) | 10,750 (56.5) | 9,400 (64) |
| 34 | | | 9,350 (40) | 9,480 (53.5) | 8,850 (61.5) |
| 36 | | | 8,460 (36) | 8,590 (51) | 8,400 (60) |
| 38 | | | 7,680 (31) | 7,830 (48.5) | 7,940 (57) |
| 40 | | | 7,000 (25) | 7,150 (45.5) | 7,270 (55) |
| 42 | | | 6,400 (17.5) | 6,550 (42.5) | 6,680 (53) |
| 43.5 | | | 6,000 (0) | 6,000 (40.5) | 6,270 (51.5) |
| 46 | | | | 5,440 (36) | 5,680 (48.5) |
| 48 | | | | 5,040 (32.5) | 5,250 (46.5) |
| 50 | | | | 4,680 (28) | 4,860 (44) |
| 52 | | | | 4,350 (23) | 4,510 (41.5) |
| 54 | | | | 4,040 (16) | 4,190 (38.5) |
| 55.5 | | | | 3,820 (0) | 3,960 (36.5) |
| 58 | | | | | 3,620 (32.5) |
| 60 | | | | | 3,370 (29) |
| 62 | | | | | 3,130 (25) |
| 64 | | | | | 2,920 (20) |
| 66 | | | | | 2,720 (13) |
| 67 | | | | | 2,620 (0) |

| Feet | 23 | 35 | 47 | 59 | 70.5 |
|------|---------------|---------------|---------------|---------------|--------------|
| 8.5 | 26,350 (63.5) | 24,000 (73) | 21,900 (78) | | |
| 10 | 20,800 (59) | 19,300 (70.5) | 17,900 (76) | 16,650 (79.5) | |
| 12 | 16,000 (52.5) | 15,100 (67) | 14,200 (73.5) | 13,350 (77.5) | |
| 14 | 12,300 (45.5) | 12,250 (63) | 11,600 (71) | 11,000 (75.5) | 10,500 (79) |
| 16 | 9,850 (37) | 10,150 (59.5) | 9,710 (68.5) | 9,280 (73.5) | 8,870 (77) |
| 18 | 8,070 (26) | 8,370 (55.5) | 8,230 (65.5) | 7,910 (71.5) | 7,590 (75.5) |
| 19.5 | 7,090 (0) | 7,300 (52) | 7,330 (63.5) | 7,060 (70) | 6,810 (74) |
| 22 | | 5,900 (46.5) | 6,050 (60) | 5,900 (67.5) | 5,720 (72) |
| 24 | | 5,040 (41.5) | 5,170 (57) | 5,150 (65) | 5,000 (70) |
| 26 | | 4,330 (36) | 4,450 (54) | 4,520 (63) | 4,400 (68.5) |
| 28 | | 3,740 (29) | 3,850 (51) | 3,930 (60.5) | 3,880 (66.5) |
| 30 | | 3,250 (20) | 3,340 (47.5) | 3,410 (58.5) | 3,420 (65) |
| 31.5 | | 2,910 (0) | 3,010 (45) | 3,080 (56.5) | 3,120 (63.5) |
| 34 | | | 2,530 (40) | 2,590 (53.5) | 2,640 (61) |
| 36 | | | 2,200 (36) | 2,260 (51) | 2,310 (59) |
| 38 | | | 1,910 (31) | 1,960 (48.5) | 2,010 (57) |
| 40 | | | 1,660 (25) | 1,700 (45.5) | 1,750 (55) |
| 42 | | | 1,410 (17.5) | 1,470 (42.5) | 1,510 (53) |
| 43.5 | | | 1,230 (0) | 1,310 (40.5) | 1,350 (51.5) |
| 46 | | | | 1,070 (36) | 1,110 (48.5) |
| 48 | | | | 890 (32.5) | 930 (46.5) |
| 50 | | | | 720 (28) | 780 (44) |
| 52 | | | | 570 (23) | 630 (41.5) |
| 54 | | | | 430 (16) | 500 (38.5) |
| 55.5 | | | | 330 (0) | 410 (36.5) |
| 58 | | | | | 270 (32.5) |

*NOTE: () Boom angles are in degrees.

THIS CHART IS ONLY A GUIDE AND SHOULD NOT BE USED TO OPERATE THE CRANE.

The individual crane's load chart, operating instructions and other instructional plates must be read and understood prior to operating the crane

LOAD CHART

Imperial 85%



17 ft



4,700 lb



100%



360°



Pounds

| Main Boom Angle (°) | 15 ft Length | | | | |
|---------------------|-----------------------|-------------------------|-----------------------|-------------------------|-----------------|
| | 0° OFFSET | | 15° OFFSET | | 30° OFFSET |
| | Up to 59' boom length | Up to 70.5' boom length | Up to 59' boom length | Up to 70.5' boom length | Any boom length |
| 80 | -- | -- | 5,000 | 5,000 | 3,500 |
| 75 | 7,500 | -- | 4,400 | 4,400 | 3,100 |
| 70 | 6,100 | -- | 3,900 | 3,900 | 2,800 |
| 65 | 5,000 | 4,600 | 3,500 | 3,500 | 2,550 |
| 60 | 4,300 | 3,800 | 3,150 | 3,150 | 2,350 |
| 55 | 3,800 | 3,300 | 2,850 | 2,850 | 2,200 |
| 50 | 3,400 | 2,900 | 2,600 | 2,600 | 2,100 |
| 45 | 3,050 | 2,600 | 2,400 | 2,400 | 2,000 |
| 40 | 2,800 | 2,400 | 2,250 | 2,250 | 1,950 |
| 35 | 2,600 | 2,150 | 2,150 | 2,050 | 1,900 |
| 30 | 2,400 | 1,930 | 2,080 | 1,850 | 1,830 |
| 25 | 2,300 | 1,750 | 2,050 | 1,720 | - |
| 20 | 2,200 | 1,600 | 2,000 | 1,590 | -- |
| 15 | 2,100 | 1,500 | 1,950 | 1,520 | -- |
| 10 | 2,050 | 1,460 | -- | -- | -- |
| 5 | 2,020 | 1,450 | -- | -- | -- |
| 0 | 2,000 | 1,440 | -- | -- | -- |

NOTES:

1. 17 ft boom extension may be used for single line lifting service only.
2. WARNING: Operation of this machine with heavier loads than the capacities listed is strictly prohibited. Machine tipping with boom extension occurs rapidly and without advance warning.

THIS CHART IS ONLY A GUIDE AND SHOULD NOT BE USED TO OPERATE THE CRANE.

The individual crane's load chart, operating instructions and other instructional plates must be read and understood prior to operating the crane

LOAD CHART

Imperial 85%



23 ft –
70.5 ft



4,700 lb



Stationary



Defined Arc
Over Front



Stationary



360°



Pick &
Carry



Over
Front



Pounds

| Radius in Feet | Defined Arc 15° Over Front | Stationary 360° |
|----------------|----------------------------|-----------------|
| 6 | 30,000 | 21,000 |
| 8 | 24,900 | 17,900 |
| 10 | 21,000 | 15,900 |
| 12 | 18,000 | 13,000 |
| 14 | 15,650 | 10,000 |
| 16 | 13,300 | 7,920 |
| 18 | 10,900 | 6,410 |
| 20 | 9,460 | 5,780 |
| 22 | 8,060 | 4,880 |
| 24 | 6,960 | 4,140 |
| 26 | 6,050 | 3,520 |
| 28 | 3,500 | 2,990 |
| 30 | 4,670 | 2,540 |
| 32 | 4,130 | 2,160 |
| 34 | 3,670 | 1,820 |
| 36 | 3,260 | 1,530 |
| 38 | 2,900 | 1,270 |
| 40 | 2,590 | 1,040 |
| 42 | 2,300 | 830 |
| 44 | 2,280 | 720 |
| 46 | 2,050 | 610 |
| 48 | 1,840 | 500 |
| 50 | 1,650 | 390 |
| 52 | 1,480 | 280 |
| 54 | 1,320 | -- |
| 56 | 1,220 | -- |
| 58 | 1,080 | -- |
| 60 | 950 | -- |
| 62 | 840 | -- |
| 64 | 730 | -- |
| 66 | 620 | -- |
| 67 | 570 | -- |

NOTES:

1. Capacities are in pounds and do not exceed 75% of tipping loads as determined by test in accordance with SAE J765.
2. Capacities are applicable to machines equipped with 17.5x25 at 110 psi cold inflation pressure.
3. Capacities are applicable only with machine on a smooth, level and firm surface.
4. Defined Arc – Over front includes 15° on either side of longitudinal centerline of machine.
5. All rubber lifting depends on proper tire inflation, capacity and condition. Capacities must be reduced for lower tire inflation pressures. Damaged tires are hazardous to safe operation of crane.
6. For pick and carry operation, the boom, using the shortest practical boom length, must be centered over front of machine. Maximum speed is 2.5 mph.
7. On rubber lifting with boom extension not permitted.

THIS CHART IS ONLY A GUIDE AND SHOULD NOT BE USED TO OPERATE THE CRANE.

The individual crane's load chart, operating instructions and other instructional plates must be read and understood prior to operating the crane

TRANSPORTATION & LIFTING

1. Lifting of entire crane or major crane assemblies must be accomplished by utilizing specific fittings indicated on adjacent chart. Use of fittings for purposes other than those designated on chart is prohibited. Fitting capacities are maximum allowable loads per individual fitting.
2. Rigging personnel shall be responsible for proper selection and placement of all slings and load handling devices.
3. Dimensions and weights shown are estimated for largest configuration available. Weights do not include boom extension and or jib, unless otherwise indicated.
4. Rigging personnel shall verify dimensions as required for clearance.
5. Do not use counterweight lift locations or boom sling point for lifting or tie down of entire crane.
6. Lifting of the counterweight to be accomplished with a properly rated 1.25" - 7 inch eyebolt.

| FITTING | NO. / UNIT | LIFT | TOW | TIE DOWN | BOOM | CWT | CAPACITY TONS (TONNES) | | | | | | |
|---------|------------|------|-----|----------|------|-----|------------------------|--------------|--------------|------------|--------------|------|------|
| | | | | | | | LIFT | LIFT | LIFT | TOW | TIE DOWN | | |
| | | | | | | | | | | | FORE & AFT | SIDE | DOWN |
| A | 4 | X | X | X | | | 10 (9,1) | 30 (27,2) | 30 (27,2) | 1 (0,9) | 30 (27,2) | | |
| B | 4 | | | | X | | 2 (1,8) | | | | | | |
| C | 4 | | | | | X | 1 (0,9) | | | | | | |

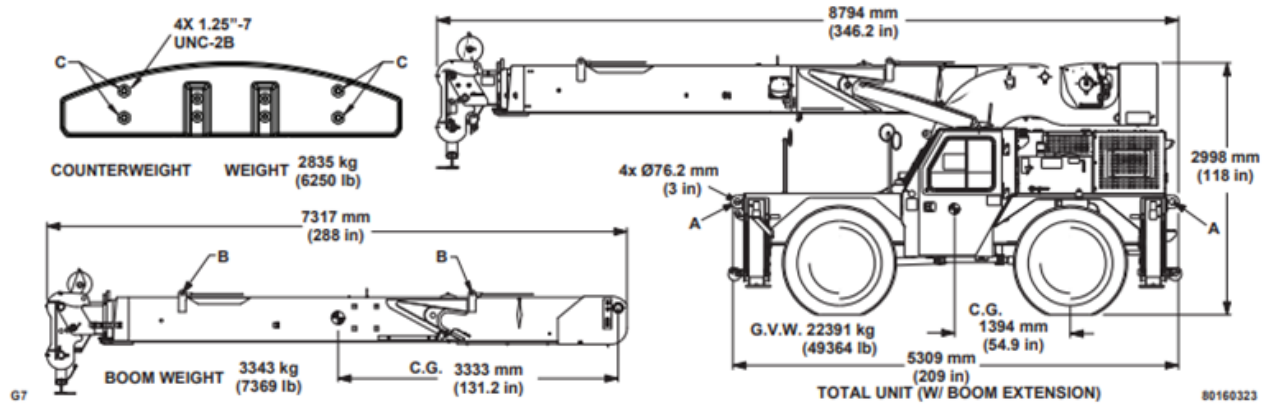

Load Distribution For Carrydeck

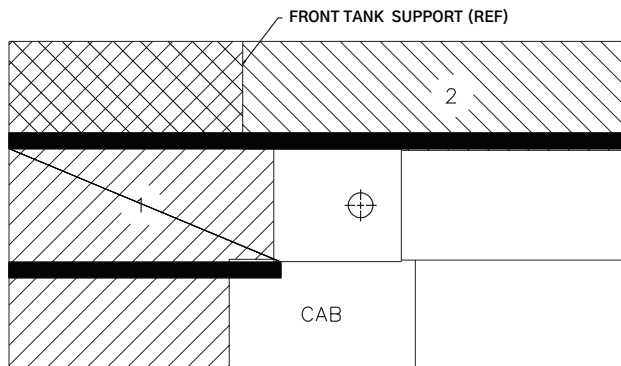

Maximum Allowable Uniformly Distributed Load

AREA 1
13 610 kg
(30,000 lb)

OR

AREA 2
6805 kg
(15,000 lb)

1. Maximum travel speed with any or all loads - 4,0 km/h (2.5 mph).
2. Loads to be transported on smooth level firm surfaces only.
3. Boom must be retracted and in center forward position, and lowered as much as the load allows.
4. Pick and carry loads may be transported on either Deck Area 1 or Deck Area 2; combined loading of Deck Area 1 and Deck Area 2 not permitted.
5. Lifting is not permitted when carry deck is loaded except for loading and unloading carry deck.
6. The maximum pick and carry loads may be transported on Deck Area 1 provided the load is centered over the front axle and cribbed directly on the frame rails.

LOAD HANDLING

Weight Reductions for Load Handling Devices

| 17 ft (5,2 m) Fixed Offsettable Extension | |
|---|-------------------|
| *Stowed | N/A |
| *Erected | 1,120 lb (508 kg) |
| *Reduction of main boom capacities | |
| When lifting over swingaway and/or jib combinations, deduct total weight of all load handling devices reeved over main boom nose directly from swingaway or jib capacity. | |

| Hook Blocks And Headache Balls | |
|--|-------------------|
| 25 USt (22,7 t), 2 sheave hook bloc | 475 lb+ (215 kg+) |
| 6.25 USt (5,7 t) headache ball | 105 lb+ (48 kg+) |
| +Refer to rating plate for actual weight | |
| NOTE: All load handling devices and boom attachments are considered part of the load and suitable allowances MUST BE MADE for their combined weights. Weights are for Shuttlelift furnished equipment. | |

| Tire Inflation – Bar (PSI) | | | |
|-----------------------------|------------|---------------------|--|
| Size (Front & Rear) | Load Range | Load Speed Index | Lifting Service, General Travel & Extended Travel |
| | | | Static & 2.5 MPH (4,0 KMh) |
| OUTRIGGER 17.5x25 E3/L-3 | 20 PR | -- | 110 (7,6) |

LOAD HANDLING

Capacity Reductions for Synthetic Rope Use

If synthetic rope is installed on the hoist, the following capacity reductions apply:

| | Main Boom Charts | Extension Charts |
|---|------------------|------------------|
| Outriggers fully extended – 360° or retracted over front/rear | 80 lb (36 kg) | 0 lb (0 kg) |
| Outriggers retracted 360° | 270 lb (122 kg) | N/A |
| On rubber | 100 lb (45 kg) | N/A |

Lifting Area Diagram

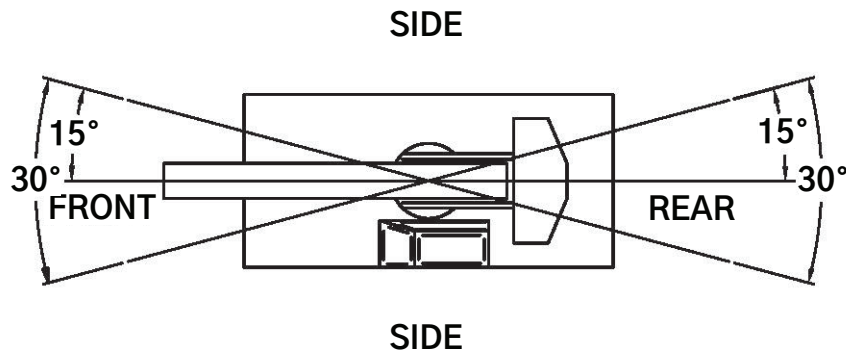

Line Pulls and Reeving Information

| Hoists | Cable Specs. | Permissible Line Pulls | Nominal Cable Length |
|--------|---|------------------------|----------------------|
| Main | <ul style="list-style-type: none"> - 5/8" (16 mm) 35 x 7 EEIPS+ - Uniropo Python Dynamiq - Min. breaking strength: 62,500 lb (28 349 kg) | 12,500 lb (5670 kg)* | 390 ft (119 m) |

The approximate weight of 5/8" (16 mm) wire rope is 0.87 lb/ft (1.3 kg/m).

*With certain boom and hoist tackle combinations, the allowable line pull may be limited by hoist performance. Refer to Hoist Performance table for lift planning to ensure adequate hoist performance on drum rope layer required.

SPECIFICATIONS

Superstructure



Boom

23 ft 8 in – 71 ft (7,21 m – 21,6 m) full power main boom. Four-section boom with three (3) powered sections. Maximum tip height: 79 ft (24,0 m).



*Optional Swingaway Extension

17 ft (5,1 m) offsettable swingaway extension. Offsets 0°, 15° and 30° via pivoting boom nose. Stows alongside base boom section. Maximum tip height: 95 ft (28,9 m).



Boom Nose

Two nickel plated steel sheaves mounted on heavy-duty tapered roller bearings with removable pin-type rope guards. Quick reeve type boom nose with four-position (0°, +30°, +60°, and +80°) pivoting to minimize head height requirements. Lowers head height by 2 ft (0,6 m).



Boom Elevation

Two double acting hydraulic cylinders with integral holding valves provides elevation from -0° to +80°.



Anti-two Block Device

Standard anti-two block device, which, when activated, provides an audible warning to the operator and “locks-out” all functions whose movement can cause two-blocking.



Rated Capacity Limiter (RCL)

Full-color, graphical display of boom angle, boom length, boom radius, rated load, and calculated load. Allows for operator inputs to set the crane configuration. RCL system is hardwired and calculates load via pressure transducers in the lift cylinder. Display includes a color-coded light bar and audible alarm with function cut-out if load exceeds the load chart parameters.



Swing

Ball bearing swing circle with 360° continuous rotation. Hydraulic motor driven pinion with brake. Maximum speed: 2,5 rpm.



Hydraulic System

One pressure compensated variable displacement axial piston pump with load sensing.

Maximum output of: 208 lpm (55 gpm).

Maximum operating pressure: 241 bars (3500 psi).

Four-section valve bank, chassis mounted, operated via dash mounted, hydraulic pilot controls. 55 gal (208 L) hydraulic reservoir with sight level gauge and steel side plating to guard against side impacts.

5 micron return line filter with full flow by-pass protection and service indicator.



Hoist Specifications

Piston motor driven with automatic spring-applied / hydraulically released wet brake. Drum rotation indicator in the hoist joystick control and hoist direction indicator light on dashboard.

- Maximum hoist pull (first layer): 15,000 lb (6804 kg)
- Maximum permissible single line pull: 12,500 lb (5670 kg) (5:1 design factor)
- Maximum single line speed: 441 fpm (134 m/min)
- Rope construction: 35 x 7 EEIPS+
- Rope diameter: 5/8 in (16 mm)
- Rope length: Main hoist: 390 ft (119 m)
- Maximum rope stowage: Main hoist: 554 ft (168 m)

SPECIFICATIONS

Carrier



Chassis

High-strength alloy frame constructed with integral outrigger housings; front and rear lifting, tie-down, and towing lugs. 60 ft² carrydeck size with 30,000 lb (13 608 kg) deck only carrying capacity. Deck coated with anti-skid treatment.



Outriggers

Hydraulic telescoping beam with vertical jack at the four corners provides extended and down and retracted and down lifting capacities. Integral holding valves on the jack cylinders.

Outrigger pad size: 11.5 in x 11.5 in (29,2 cm x 29,2 cm)

Maximum outrigger pad load: 41,500 lb (18 825 kg) / 339 p.s.i.



Outrigger Controls

Independent outrigger control rocker switches for beam or jack selection with separate extend/retract rocker switch. 360° bubble level located inside cab.



Engine (EPA Tier 4F)

Cummins QSB 4.5 L, four-cylinder, turbo-charged diesel rated at 130 hp (97 kW) at 2500 rpm. Standard 110 V engine block heater and cold weather intake grid heater.

Diesel oxidation/catalyst and SCR device to meet EPA Tier 4 Final emissions, combined with a Cummins direct air flow, two-stage air filter system with built-in pre-cleaner.

Maximum torque: 459 ft lb (622 N-m) at 1500 rpm.

Note: Tier 4F engine required in North American countries.

Fuel requirements: Maximum of 15 ppm ultra-low sulfur diesel fuel and diesel exhaust fluid (DEF).



Engine (EPA Tier 3)

Cummins QSB 4,5L, four cylinder / turbo-charged diesel rated at 130 bhp (97 kW) (gross) at 2500 rpm. Standard 110 V engine block heater and cold weather intake grid heater. Engine hour meter located inside operators compartment.

Maximum gross torque: 459 ft lb (622 N-m) at 1500 rpm.

Note: Required for sale outside of North American and European Union countries.

Fuel requirements: Maximum of 5000 ppm. Sulfur diesel fuel.



Fuel Tank Capacity

50 gal (189 L). DEF (diesel exhaust fluid): 5 gal (19 L).



Transmission

Powershift with four speeds forward and three speeds reverse. Stalk mounted direction shifter with rotary gear selection.



Operators Control Station

Frame mounted, open air style control station with cab shell includes all crane functions, driving controls, and overhead safety glass. Other standard equipment includes a suspension seat with seat belt, hour meter, sight level bubble, and 2.5 lb (1,1 kg) fire extinguisher.

The dash panel includes a multi-cluster gauge showing fuel, water temperature, DEF gauge, battery voltage and engine fault codes. An engine monitoring indicator lamp shows engine warning, stop engine, wait to start, transmission high temperature, low brake system pressure, hydraulic oil temperature and DEF status indicators. The RCL display is mounted to the top of the front dash.



*Operators Control Station-Enclosed

Includes the standard cab shell with the addition of front, rear, and right side glass, a split (2 piece) hinged door with sliding glass, front windshield wiper and washer, hot water heater and defroster with fan and cab dome light are included.



Electrical system

Two 12 V maintenance-free batteries, 730 CCA each at 0°. 130 amp alternator.



Drive

Two wheel (rear drive) or four wheel selection, front and rear axle drive with planetary hubs and limited slip differential.

SPECIFICATIONS

Carrier (cont.)



Steering

Standard three steering modes. Front two-wheel, four-wheel coordinated, and four-wheel crab steer with electronic self alignment, three-position rocker selector on dash panel.

Outside turning radius:

Two-wheel steer: 24 ft (7,32 m)

Four-wheel steer: 13 ft 3 in (4,04 m)



Axles

Front: Drive/steer with differential and planetary reduction hubs, axle is rigid mounted to frame.

Rear: Drive/steer with differential and planetary reduction hubs, axle is pivot mounted to frame allows up to 3.5° of oscillation.



Oscillation lockouts

Manual switch to engage and disengage the rear axle lockouts. Engage when lifting on rubber and in crab steer mode, disengage to allow oscillation when traveling over rough terrain.



Brakes

Hydraulic actuated internal wet-disc service brake acting on all four wheels. Dash mounted toggle switch with light for activating or release of the dry disc parking brake mounted on the transmission output yoke.



Tires

Standard: 17.5 x 25 bias



Lights

Full lighting including turn indicators, head, tail, brake and hazard warning lights recessed mounted.



Maximum Speed

19.4 mph (31,22 km/h)



Gradeability (theoretical)

63%..... (at engine stall) no load

38%..... (at engine stall) with 30,000 lb (13 608 kg) deck load



Gross Vehicle Weight (GVW)

Open cab: 45,465 lb (20 623 kg)

Enclosed cab: 45,698 lb (20 729 kg)

Miscellaneous Standard Equipment

- 25 USt (22 t) two-sheave “painted block” hook block, with “quick reeve.”
- Back-up motion alarm
- Outrigger motion alarm
- Dual rear-view mirrors
- Hoist drum rotation indicator

*Optional Equipment

- Auxiliary lighting: includes amber strobe light and boom mounted work lights
- Convenience package: includes front and rear pintle hitch and headlight/taillight grille covers
- Enclosed cab package: includes heater and defroster, cab dome light, all window glass, and two-piece split door
- Offsettable swing away boom extension with hook and ball
- Air conditioner
- Wire rope third wrap indicator with hoist function cut-out
- 8,000 lb (3629 kg) below-deck mounted tow winch
- Foam-filled tires
- RCL system includes a full color graphical display, work area definition (WADS), and is datalogger capable (requires activation)
- Below-deck winch

SYMBOLS GLOSSARY



Axles



Chassis



Gross Vehicle Weight (GVW)



Rotation



Anti-Two Block Device



Counterweight



Hoist



Speed



Boom



Drive



Hydraulic System



Steering



Boom Elevation



Electrical System



Lights



Swing



Boom Extension



Engine



Outriggers



Tires



Boom Nose



Extension



Outrigger Controls



Transmission



Brakes



Fuel Tank Capacity



Radius



Cab



Gradeability



Rated Capacity Limiter (RCL)



NOTES



NOTES



NOTES

The Manitowoc Company, Inc.

Regional headquarters

Americas

Milwaukee, Wisconsin, USA
Tel: +1 414 760 4600

Shady Grove, Pennsylvania, USA
Tel: +1 717 597 8121

Europe and Africa

Dardilly, France – TOWERS
Tel: +33 (0) 4 72 18 20 20

Wilhelmshaven, Germany – MOBILE
Tel: +49 (0) 4421 294 0

APAC

Shanghai, China
Tel: +86 21 6457 0066

Singapore
Tel: +65 6264 1188

Middle East and India

Dubai, UAE
Tel: +971 4 8862677

© 2025 The Manitowoc Company, Inc.
Form No. SCD25
Part No. 17-015/0324

This document is non-contractual. Constant improvement and engineering progress make it necessary that we reserve the right to make specification, equipment, and price changes without notice. Illustrations shown may include optional equipment and accessories and may not include all standard equipment.



[manitowoc.com](https://www.manitowoc.com)