

GROVE GMK7450

Maintenance manual

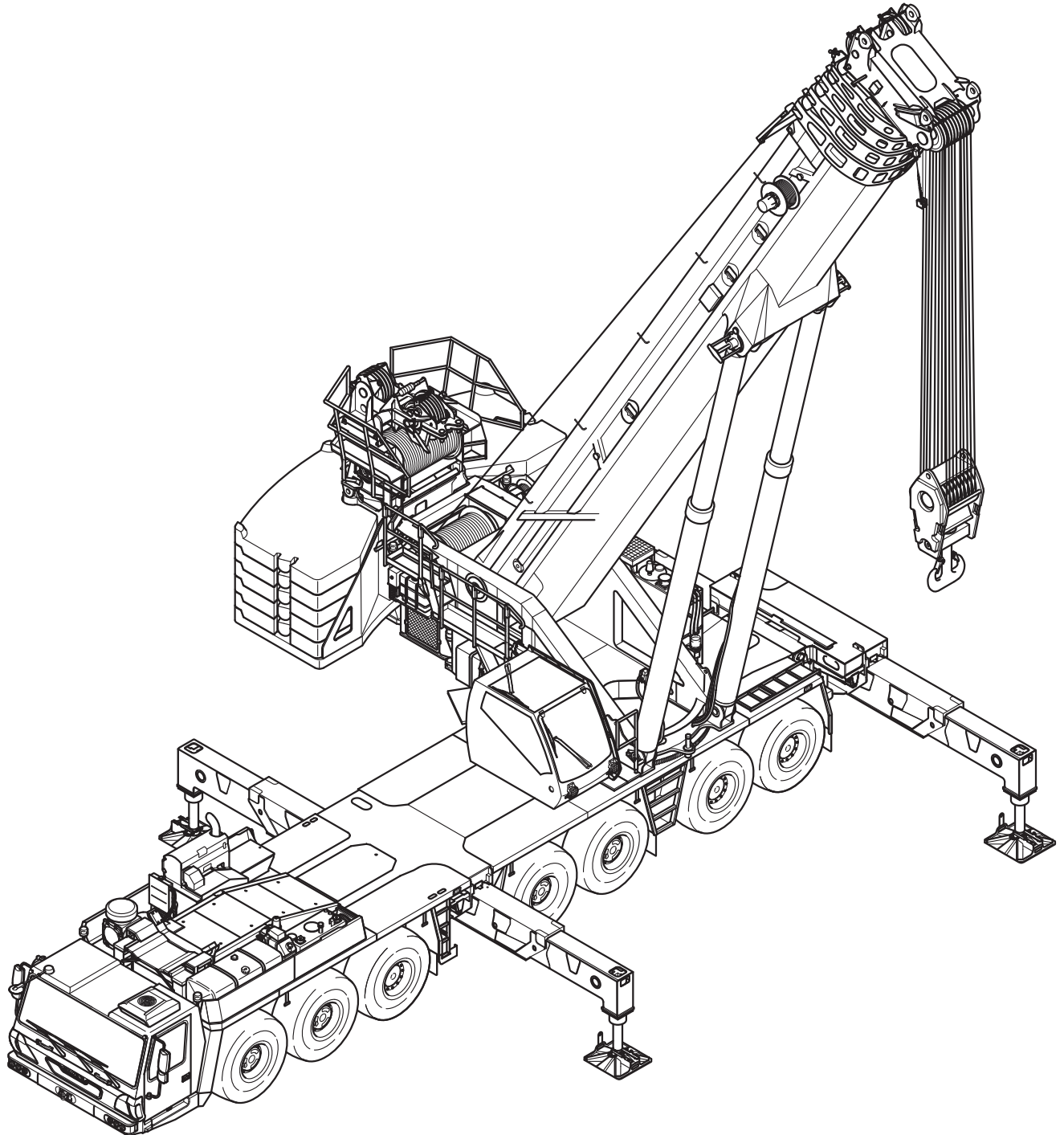

3 302 577 en

16.08.2018

 **Manitowoc**[®]

Important note

Any type of duplication or excerpt from this document, even in electronic form, is not subject to the revision service of **Manitowoc Crane Group Germany GmbH**.

© Copyright reserved by

Manitowoc Crane Group Germany GmbH

Industriegelände West

D-26389 Wilhelmshaven, Germany

Tel: [+49] (0)44 21 294-0

Fax: +[49] (0) 44 21 294-301

The passing on or duplication of this document as well as the utilisation and disclosure of its contents is prohibited unless expressly permitted. Infringement will incur liability for compensation. All rights pertaining to registration of patent or utility model are reserved. The original language of this document is German.

16.08.2018

Contents

- 1 General instructions**
 - 2 Safety and environmental protection**
 - 3 Cleaning**
 - 4 Run-in regulations**
 - 5 Maintenance overview**
 - 6 Lubricants and consumables**
 - 7 Maintenance work on the carrier**
 - 8 Maintenance work on the superstructure**
 - 9 Longer out of service periods**
 - 10 Torques**
 - 11 Spare parts required for maintenance**
- Appendix**

**This maintenance manual does not replace the operating manual.
Details of operation and standard safety instructions can be found in the
operating manual.**

Blank page

1 General instructions

1.1	Using the maintenance manual	1 - 1
1.2	Warnings and symbols	1 - 1
1.3	Maintenance instructions	1 - 2
1.4	Instructions regarding the electronic controls	1 - 4
1.5	Safety instructions for welding work	1 - 4
1.6	Definition of direction references	1 - 5
1.7	Conversion table for US measuring units	1 - 6

1

General instructions

1.1

Using the maintenance manual

This maintenance manual is not designed to replace proper training and instructions!

Maintenance personnel for this truck crane must have the relevant, specialist knowledge and that of proper safety procedures!

Please read Chapters 1 and 2 carefully before beginning maintenance work.



Maintenance work on the lattice extensions is described in the *Lattice extension operating manual*.

1.2

Warnings and symbols

The following definitions and symbols are used in the operating instructions to highlight particularly important information:



This symbol indicates hazards related to the described operation, which can endanger persons. The type of danger (e.g. life-threatening, personal injury, risk of crushing or electric shocks) generally precedes the warning sign.



Dangers which could put objects at risk are pointed out here, e.g. damage to the truck crane or the load.



This symbol is to remind you that you are working with substances which pose a risk to the environment. Take particular care. The measures required for the corresponding maintenance work are indicated next to the symbol. You will find more detailed information in Section *Handling substances that are harmful to the environment*, p. 2 - 4.

The vertical line to the left of the text indicates that: This text, regardless of its length, relates to the warning symbol.





The hand with the pointing finger indicates passages that contain additional instructions and tips regarding truck crane operation.



This symbol indicates that the topic is continued on the next page. Turn to the next page!

1.3

Maintenance instructions

This maintenance manual is intended for maintenance personnel. The maintenance manual does not contain information on repair work. Repair work may only be carried out by a qualified repair crew (e.g. **Manitowoc Crane Care**).

Repair work also requires:

- appropriate workshop equipment,
- special tools and
- spare parts approved by **Manitowoc Crane Group Germany GmbH**.

It is your responsibility to maintain and service the truck crane regularly and carefully in order to extend its service life and keep it in good working order.

Please note that **Manitowoc Crane Group Germany GmbH** can only uphold the warranty provided for the truck crane when the following conditions are met:

- It is used for the purpose for which it was intended,
- Care and maintenance are carried out as prescribed,
- Repair work/overhauling is carried out by qualified personnel.

Many defects and failures are caused by **improper maintenance** such as:

- Insufficient oil, grease or antifreeze,
- Dirt,
- Damage to the ropes,
- Faulty compressed air and hydraulic systems,
- Damaged hoses or loose screw connections,
- Faulty brakes,
- Faulty tyres or wheel rims,
- Exceeded maintenance intervals.

For your safety and the safety of others, avoid these errors by carrying out maintenance work carefully within the specified intervals. Do not put off maintenance work that is due. If repairs are needed, immediately contact **Manitowoc Crane Care** or an authorised GROVE dealer or your repair crew. This work may only be carried out by trained, qualified personnel.

A few **general maintenance instructions**:

- Clean the parts of the truck crane that are to be serviced, particularly the area around the oil filler opening, the oil inspection opening, the oil drain opening and the lubricating nipples.
- When changing the oil, it should run out at operating temperature.
- Ensure that only oils and lubricants approved in the *Lubricants*, p. 6 - 1 are used.
- Replace all filters within the specified period if cleaning is not explicitly permitted.
- Always replace all gaskets before assembly. Clean the sealing surfaces.
- Tighten loose screw connections on hydraulic and compressed air systems only when the system is depressurised.
- Keep brake and clutch linings free of grease.
- Replace hydraulic hoses immediately once damage or moisture penetration becomes visible.
- Cleanliness is imperative when handling hydraulic oil. Even when filling with fresh hydraulic oil, it must be filtered.



- Cleanliness is imperative when handling grease for the central lubrication system. Do not remove the caps from the filling hole and grease gun until immediately before refilling the grease.
- Check fastening and retaining elements (nuts, bolts, lock washers etc.) before re-using them and replace them if necessary.

Torques can be found in Sections p. 10 - 1 and p. 10 - 2.

The training centre at our factory offers specialised training programmes for your qualified personnel.

Please contact **Manitowoc Crane Care**.

The vehicle must meet all current regulations applicable to it before being put into operation and driven on public roads.

1.4

Instructions regarding the electronic controls

The electronic ESX control is designed for a service life of 10 years. In terms of use, the control system's service life can be estimated based on the following limiting factors:

- The service life of the EEPROM allows 10^6 accesses.
- The maximum number of make-and-break cycles for the safety relay is 10^7 .
- Some conventional capacitors in the ESX have a service life of 10 years.

These devices must be serviced or replaced by **Manitowoc Crane Care** before one of these limits is reached.

1.5

Safety instructions for welding work

To avoid damage, especially to electronic parts, there are certain measures you must take before doing any welding work. You should therefore, always consult **Manitowoc Crane Care** before any welding work.

All welding work (especially on load carrying members) may only be performed by qualified expert personnel with the prior written permission from **Manitowoc Crane Group Germany GmbH**.

1.6

Definition of direction references

Basic rule

Directions always depend on whether the carrier or the superstructure is being operated.

On the carrier

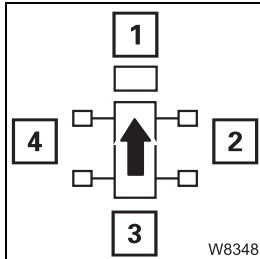

The driver's cab is always at the front, which means that:

- | | |
|----------|----------|
| 1: front | 2: right |
| 3: rear | 4: left |

Forwards always means with driver's cab leading,
Backwards always means the rear lights on the carrier are to the front.

On the superstructure

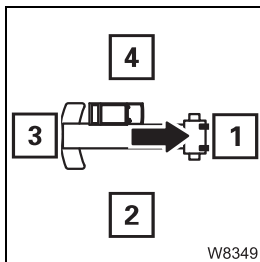

The main boom head is always at the front, which means that:

- | | |
|----------|----------|
| 1: front | 2: right |
| 3: rear | 4: left |

Switches and buttons

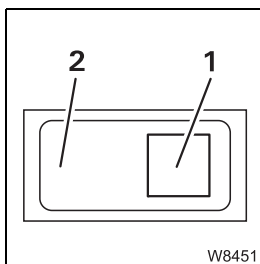

For switches and buttons, the terms **at the bottom** and **at the top** are used.

Regardless of the fitting position (vertical, horizontal, diagonal, transverse or turned), the following always applies:

- At the bottom:** press in at (1) – next to the symbol
At the top: press in at (2) – opposite the symbol

1.7**Conversion table for US measuring units**

The following conversion factors will help you convert from metric to US units when the truck crane is used in countries that use US units of measurement and vice versa.

Converting from	in	Multiply by
mm	in	0.03937
in	mm	25.4
m	ft	3.28084
ft	m	0.30479
m ²	ft ²	10.76391
cm ²	in ²	0.155
cm ³	in ³	0.061
l	gal (US)	0.264178
kg	lbs	2.204622
lbs	kg	0.45359
t	lbs	2,204.622
lbs	t	0.0004536
kN	lbf	224.809
daN/cm ²	lbf/in ²	14.50378
lbf/in ²	daN/cm ²	0.06895
bar	psi	14.50378
psi	bar	0.06895
m/s	ft/s	3.28084
km/h or km	mph or mi	0.62137
mph or mi	km/h or km	1.60935
Nm	lbf ft	0.7375
°C	°F	1.8 x °C + 32
°F	°C	(°F-32)/1.8
t/m ²	lbs/ft ²	204.8
m ² /t	ft ² /lbs	0.04882
MPa	bar	10
bar	MPa	0.1

2 Safety and environmental protection

2.1	Safety rules	2 - 1
2.1.1	Securing against unauthorised use	2 - 3
2.2	Handling substances that are harmful to the environment	2 - 4
2.3	Disposal of the truck crane	2 - 6

2

Safety and environmental protection

2.1

Safety rules

When carrying out maintenance work, please observe the applicable **accident prevention regulations**.

Observe the following safety rules:

- Familiarise yourself with the truck crane and its operation.
Read the *operating manual* carefully and request guidance from the crane operator.
- Do not carry out maintenance work on the truck crane unless you are authorised to do so.
- Observe all safety and warning signs on the truck crane.
- Observe all safety instructions contained in this *maintenance manual*.
- Familiarise yourself with the conditions under which the superstructure may be slewed and the boom may be extended into horizontal position.
- Do not carry out maintenance work unless the truck crane is standing on flat, stable ground and is secured against rolling away.
- Keep all handles, steps, railings and ladders free of dirt, grease, snow and ice.
- Use the provided, safe access aids and working platforms when carrying out work above body height. Wear a safety harness when carrying out maintenance work at a great heights.
Use your personal fall protection equipment to secure yourself from falling from the truck crane.
All locations on the truck crane designed for fastening a fall prevention safety system are marked with a *symbol*.
- Walk only on those machine parts which are equipped with appropriate tread grids and railings and therefore guarantee safety. During rigging and maintenance work on machine parts above body height which have no apparatus for walking on, always use the supplied ladder (e.g. when lubricating telescopic slide faces).

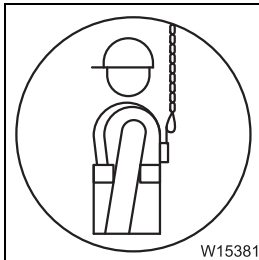

- Perform maintenance work only after the truck crane has been shut down. Always ensure that the truck crane is well-protected from unauthorised operation before beginning maintenance work. Remove the key and put up warning signs.

If due to exceptional circumstances the truck crane needs be put into operation for certain types of maintenance work, great care must be taken where there are moving parts (superstructure, outriggers, Cardan shafts, slewing bearing, engines, tiltable crane cab). There is a **risk of injury!**

- Ensure that all hydraulic components are returned to their initial positions (e.g. the main boom) or locked (e. g. the outriggers) before starting maintenance work.

Escaping hydraulic fluid or compressed air can cause severe injury. Remember that the hydraulic and compressed air systems of the truck crane are pressurised even when the truck crane is not in operation. Tighten loose screw connections only when the systems are depressurised. Always depressurise the hydraulic and compressed air systems before opening them.

- Do not allow hot fluids to escape in an uncontrolled manner. Risk of scalding!
- Observe the applicable safety regulations when working with flammable fluids.
- Observe the applicable safety regulations when working with process materials.
- Switch off all electrical consumers and first disconnect the earthing terminal before removing any electrical batteries.
- Keep in mind the corrosive effect of battery acid.
- Note the fire alarm and fire-fighting facilities on site.
- Return the truck crane to proper working order once maintenance work is completed. Inform the crane operator accordingly.

2.1.1

Securing against unauthorised use

- Secure the truck crane against unauthorised use by:
 - Applying the parking brake,
 - Switching the transmission to position **N**,
 - Turning off the engine,
 - Removing the ignition key and
 - Stowing away the hand-held control in the crane cab or in the driver's cab,
 - Locking the driver's cab and the crane cab.



Danger due to unauthorised use!

Always stow away the hand-held control in the crane cab or in the driver's cab before leaving the truck crane and lock the doors.

This way you can prevent unauthorised persons from starting the engine with the hand-held control.

- Set up warning signs in the driver's cab and in the crane cab with information about
 - when,
 - why,
 - and by whom

the truck crane was secured to prevent unauthorised use.

Remove the warning signs from the driver's cab and the crane cab after **completion** of the maintenance work.

2.2

Handling substances that are harmful to the environment

Which substances are harmful to the environment?

When you carry out maintenance work on the truck crane you will occasionally work with consumables which are classified as harmful to the environment by applicable national and regional regulations.

These include oil, fuel, grease, used oil and fuel filters, as well as rags which have come into contact with these environmentally harmful substances.

- When handling these substances observe the applicable national and regional regulations as well as the instructions in this chapter.

Using suitable equipment

Substances harmful to the environment can sometimes be corrosive. When doing maintenance work involving these consumables (oils, coolant, fuel) always use receptacles, hoses, pumps, funnels etc. which have sufficient capacity and which are resistant to the consumables.

For oil samples, always use receptacles that can be closed and have sufficient capacity and resistance to the consumables.

The approximate amount of consumables to be expected is specified in the maintenance plans.

Filling and draining

- When filling and draining, make absolutely sure that no substances harmful to the environment seep into the earth, escape into the sewage system or pollute natural waters.
- Collect consumables (e.g. oils, fuels, coolant) in a suitable receptacle when draining.
- Always use a drain hose when draining, and a funnel or a pump with a hose suitable for the respective substance when filling.

Separate collection and storage

Substances which are harmful to the environment should always be collected separately from other waste.

- Ask your local environmental protection authority about the different categories of the substances.
- Also, when collecting substances which are harmful to the environment, keep solid materials (e.g. filter cartridges) separate from fluids. Disposal costs will be reduced if you collect fluids separately according to defined categories.
- Store environmentally harmful substances only in approved receptacles and in locations which meet the requirements of applicable national and regional regulations.

Disposal

- Ask your local environmental protection authority about the prescribed disposal options.
- Once collected, have environmentally harmful substances disposed of only by disposal companies which are approved by the national or regional authority responsible.

2.3

Disposal of the truck crane

Since you are the owner/operator, you can be faced with responsibility for the proper, orderly and final decommissioning, disposal and scrapping of the truck crane.

Before you decide to finally decommission your truck crane and scrap it:

- Allow **Manitowoc Crane Care** to advise you about alternatives.

Proper disposal

- Find out about the applicable official regulations regarding the final de-registration and disposal at the place of registration of the truck crane.
- On site, find out about certified vehicle disposal companies.
- Have the vehicle disposal company issue a disposal certificate for the truck crane.
- Once collected, have environmentally harmful substances disposed of only by disposal companies which are approved by the national or regional authority responsible; ■■■► *Handling substances that are harmful to the environment*, P. 2 - 4.

After disposal

- Inform **Manitowoc Crane Care** about the disposal of the truck crane, specifying the serial number.

3 Cleaning

3.1	Overview of assemblies easily damaged when cleaning	3 - 2
------------	--	--------------

3

Cleaning

During the first 3 months

The paintwork on the truck crane will continue to harden for the first three months.

- During this period the crane may be cleaned only with cold water.
- Do not use high-pressure or steam jet cleaning equipment during this period.

After the first 3 months

- Avoid water temperatures above 60 °C (140 °F) even after this period.
- Do not use corrosive cleaning agents that might damage the paint.
- Never hold the spray nozzle of your cleaning unit at a right angle to the surface you are cleaning and ensure that you are standing at a sufficient distance away from the surface you are cleaning.



Risk of accidents from a misdirected high pressure water jet!

When working with high-pressure and steam-jet cleaners, the water jet will be deflected by crane parts and could spray into your face and eyes at high speed and great pressure.

Always wear a face guard when cleaning the truck crane with high-pressure and steam-jet cleaning equipment!

- To prevent damage to the gaskets, never point the spray nozzle directly at them.
- Never point the spray nozzle at electrical equipment, relay and switch boxes, suction and ventilation filters or control elements and lubricated surfaces.
- To prevent corrosion, relubricate all slide faces after cleaning.
- Keep all electric and hydraulic connections free of dirt. Check the connecting points for dust, foreign bodies and moisture before installation. This also applies to protective caps and bridging plugs.

The parts specified in the next section are particularly at risk.

- After cleaning with high-pressure or a steam jet equipment, activate intermediate lubrication on the central lubrication system (▮▮▮▮▶ *Triggering intermediate lubrication*, P. 7 - 105). Lubricate all remaining lubricating points using a grease gun.

3.1 Overview of assemblies easily damaged when cleaning

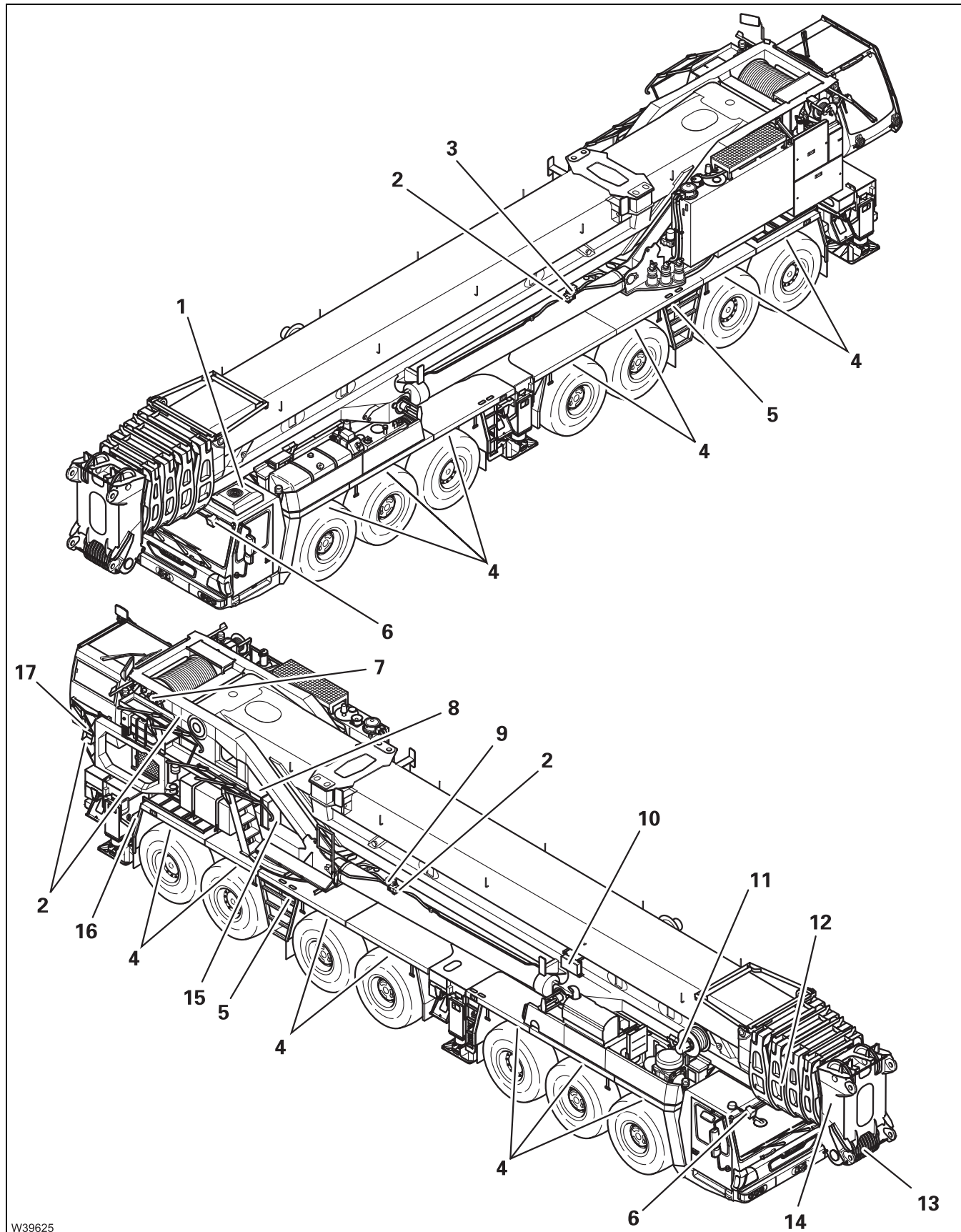

W39625

16.08.2018

- 1 Air-conditioning system in the driver's cab
- 2 Connection for the hand-held control
- 3 Derricking-cylinder pressure sensor, left
- 4 Suspension struts
- 5 Control units for outriggers
- 6 Spotlights, pivoting
- 7 Lowering limit switch
- 8 Control unit at connection 1
- 9 Derricking-cylinder pressure sensor, right
- 10 Angle sensor switch box
- 11 RCL length measuring unit
- 12 Telescopic slide faces
- 13 Lifting limit switch
- 14 RCL terminal box
- 15 Distribution box
- 16 Removable supporting box (ROB) control unit
- 17 Crane cab air-conditioning system



Assemblies at risk of damage on the lattice extension;  *Lattice extension operating manual.*

Blank page

4 Run-in regulations

4

Run-in regulations

There are regulations about running in individual parts which must be followed, after:

- **First commissioning** or
- **Part replacement** or
- **General overhaul.**

This is why you must carry out **additional maintenance work** on the **carrier** and **superstructure** at specific intervals:

Operating hours (oper. hrs.)	Driven km (mi)	Additional maintenance work on the CARRIER
	after 50 (30)	Tighten the wheel nuts; ■■■▶ <i>Special torques, P. 10 - 2.</i>
	after 150 (95)	Tighten the wheel nuts; ■■■▶ <i>Special torques, P. 10 - 2.</i>
after 50		Tighten the clips on the coolant hoses; ■■■▶ <i>Special torques, P. 10 - 2.</i>
after 100		Lubricate the outrigger beams; ■■■▶ <i>Lubricating the outrigger beams, P. 7 - 120.</i>
during the first 100		Check the hydraulic oil filter every week, and change it if necessary; ■■■▶ <i>Cleaning the magnetic rods, P. 7 - 89,</i> ■■■▶ <i>Changing the hydraulic oil filter, P. 7 - 101.</i>
after 100	after 1,000 (650)	Change the drive oil; ■■■▶ P. 7 - 52 for the transfer case, ■■■▶ P. 7 - 57 for the axle centre drives, ■■■▶ P. 7 - 60 for the final drives.
after 250	after 2,500 (1,550)	Change the engine oil; ■■■▶ <i>Engine manufacturer's documentation.</i>



Operating hours (oper. hrs.)	Additional maintenance work on the SUPERSTRUCTURE
after 50	Tighten the clips on the coolant hoses; <ul style="list-style-type: none"> ▣▣▣▣▶ <i>Special torques, P. 10 - 2.</i>
during the first 100	Check the hydraulic oil filter every week, and change it if necessary; <ul style="list-style-type: none"> ▣▣▣▣▶ <i>Oil filters 1 and 2 – cleaning the magnetic rod, P. 8 - 72,</i> ▣▣▣▣▶ <i>Changing the hydraulic oil filter, P. 8 - 78.</i>
after 100	Tighten the bolts on the slewing bearing; <ul style="list-style-type: none"> ▣▣▣▣▶ <i>Checking the screws, P. 8 - 55,</i> ▣▣▣▣▶ <i>Special torques, P. 10 - 2.</i>
after 100	Hook blocks; <ul style="list-style-type: none"> ▣▣▣▣▶ <i>Greasing, P. 8 - 115.</i>
after 200	First oil change on the hoists; <ul style="list-style-type: none"> ▣▣▣▣▶ <i>Changing the oil/checking the oil, P. 8 - 46.</i>
after 1,000 or after 12 months at the latest	Second oil change on the hoists; <ul style="list-style-type: none"> ▣▣▣▣▶ <i>Changing the oil/checking the oil, P. 8 - 46.</i>
after 200	Change the slewing gear oil; <ul style="list-style-type: none"> ▣▣▣▣▶ <i>Changing the oil/checking the oil, P. 8 - 52.</i>
after 250	Change the engine oil; <ul style="list-style-type: none"> ▣▣▣▣▶ <i>Engine manufacturer's documentation.</i>

5 Maintenance overview

5.1	Maintenance intervals	5 - 1
5.2	Maintenance plans	5 - 3
5.2.1	Maintenance plan D	5 - 4
5.2.2	Maintenance plan W	5 - 6
5.2.3	Maintenance plan M 1	5 - 8
5.2.4	Maintenance plan M 3	5 - 10
5.2.5	Maintenance plan M 6	5 - 12
5.2.6	Maintenance plan M 12	5 - 14
5.2.7	Maintenance plan Y 2	5 - 16
5.2.8	Maintenance plan Y 3	5 - 17
5.2.9	Maintenance plan Y 5	5 - 17
5.2.10	Maintenance plan Y 6	5 - 18
5.2.11	Maintenance plan Y 10	5 - 18
5.3	Periodic inspections	5 - 19
5.3.1	Load hook inspection	5 - 20
5.4	Measures required for winch monitoring	5 - 21
5.4.1	Theoretical service life	5 - 21
5.4.2	Proportion of theoretical service life used	5 - 22
5.4.3	Example	5 - 26

5

Maintenance overview

- Maintenance plans **D** (= daily),
- Maintenance plans **W** (= weekly) and
- Maintenance plans **M 1** (= once a month) to **M 12** (= every 12 months) and
- Maintenance plans **Y 2** (= every 24 months) to **Y 10** (= every 120 months).

The maintenance plans are provided in tabular form, divided into

- Maintenance work on the **carrier** and
- Maintenance work on the **superstructure**.

In the tables, cross references direct you to the sections in which the appropriate maintenance work is described. The cross references consist of the chapter number and the corresponding page number, e.g.

Check the hydraulic oil level; ■■■► P. 7 - 87.

Checking the hydraulic oil level is described in Chapter 7, the section starts on page 7 - 87.

5.1

Maintenance intervals

The length of the maintenance interval depends on the grade of oil used and operating conditions of the truck crane.

The next maintenance must be carried out after

- a specified **time (maintenance interval)** or
- a specified number of **km driven (mi)** or
- a specified number of **operating hours (oper. hrs.)** or
- an **indication** on the instrument panel in the driver's cab; ■■■► P. 7 - 9 or
- an **indication** on the side panel or ECOS display in the crane cab; ■■■► P. 8 - 11.



The **maintenance interval that occurs first** determines when the next maintenance is due.

- The **driven km (or mi)** can be taken from the speedometer.
- You can call up the individual **engine and power unit operating hours (oper. hrs.)** of the superstructure on the *ECOS* display in the crane cab. The operating hours of the engine are equivalent to the total operating hours of the superstructure.

The following table sets out the maintenance intervals for the maintenance plans:

Maintenance plans	Maintenance interval	Driven km (mi) (carrier)	Operating hours (oper. hrs.) of the engine (super-structure)
D	Daily / before putting into operation	—	—
W	Weekly	—	—
M 1	monthly	approx. 2,000 (approx. 1 240)	approx. 100
M 3	every three months	5,000 – 6,000 (3 100 – 3 730)	250
M 6	every six months	10,000 – 12,500 (6 210 – 7 770)	500
M 12	every twelve months	20,000 – 25,000 (12 430 – 15 530)	1,000
Y 2	every 24 months	40,000 – 50,000 (25 000 – 31 000)	2,000
Y 3	every 36 months	—	3,000
Y 5	every 60 months	100,000 (62 000)	5,000
Y 6	every 72 months	—	6,000
Y 10	every 120 months	200,000 (124 000)	12,000

Please note that the long-term maintenance plans always incorporate the short-term ones!

5.2

Maintenance plans

The descriptions for certain maintenance work for the maintenance plans **D**, **W**, **M 1** to **M 12** and **Y 2** to **Y 10** are provided for

- the carrier in Chapter 7 and for
- the superstructure in Chapter 8.

References (chapter and page number) to the description of this maintenance work can be found after the respective maintenance work for carrier and superstructure.

The section titles

- of Chapter 7 *Maintenance work on the carrier* and
- of Chapter 8 *Maintenance work on the superstructure*

contain the abbreviation (**D** to **Y 10**) of the relevant maintenance plan for better comprehension.

In addition to the **Maintenance work on the carrier** and the **Maintenance work on the superstructure** Chapter 6 also lists the **Lubricants and consumables**:

- The **designations** of the oils/lubricants in accordance with *Lubricants list*, p. 6 - 2.
- The **amounts** as approximate values for oil amounts in litres (l) (and US gallons (gal)) (the exact oil amounts can always be determined by the oil level inspection holes, the oil dipsticks or the oil level indicators) *Lubricant applications list*, p. 6 - 3.



Items that are only available with additional equipment are designated accordingly in Chapter 7 and Chapter 8.

Maintenance work on the engines that goes beyond the daily and weekly checks is **only partially** described in this maintenance manual! When carrying out such maintenance work, follow the instructions given in the accompanying *Engine manufacturer's documentation*.

5.2.1

Maintenance plan D

D

Maintenance work on the CARRIER: Daily/before putting into operation	
Engine – Check the oil level – Checking the air filter – Checking the coolant level	<p>▣▣▣▣▶ P. 7 - 11</p> <p>▣▣▣▣▶ P. 7 - 14</p> <p>▣▣▣▣▶ P. 7 - 15</p>
Fuel system – Checking fuel filter 1 – Draining off water from fuel filter 1	<p>▣▣▣▣▶ P. 7 - 28</p> <p>▣▣▣▣▶ P. 7 - 29</p>
Exhaust system with exhaust emission control – Checking the AdBlue tank level	▣▣▣▣▶ P. 7 - 36
Transmission – Check the oil level	▣▣▣▣▶ P. 7 - 43
Wheels – Checking the tyres for damage	▣▣▣▣▶ P. 7 - 65
Steering – Checking for leaks	▣▣▣▣▶ P. 7 - 81
Hydraulic system – Check the oil level	▣▣▣▣▶ P. 7 - 87
Electrical system – Checking the lighting and indicators	▣▣▣▣▶ P. 7 - 107

Maintenance work on the SUPERSTRUCTURE: Daily/before putting into operation	
Engine – Check the oil level – Checking the air filter – Checking the coolant level	 ▶▶▶▶ P. 8 - 13 ▶▶▶▶ P. 8 - 16 ▶▶▶▶ P. 8 - 17
Fuel system – Draining off water from fuel filter 1	▶▶▶▶ P. 8 - 28
Exhaust system with exhaust emission control – Checking the AdBlue tank level	▶▶▶▶ P. 8 - 36
Hydraulic system – Check the oil level	▶▶▶▶ P. 8 - 69
Hoist ropes – Checking the winding	▶▶▶▶ P. 8 - 97
Electrical system – Checking the lighting and indicators	▶▶▶▶ P. 8 - 117

5.2.2

Maintenance plan W

W

Maintenance work on the CARRIER: Weekly	
Engine – General inspection	▣▣▣▣▶ P. 7 - 16
Transmission – General inspection	▣▣▣▣▶ P. 7 - 47
Transfer case – General inspection	▣▣▣▣▶ P. 7 - 51
Axle lines – General inspection	▣▣▣▣▶ P. 7 - 55
Wheels – Checking the tyre pressure	▣▣▣▣▶ P. 7 - 66
Compressed air system – Draining water from the compressed air system – Checking for leaks	▣▣▣▣▶ P. 7 - 83 ▣▣▣▣▶ P. 7 - 84
Hydraulic system – Checking the hydraulic hoses – Checking for leaks	▣▣▣▣▶ P. 7 - 88 ▣▣▣▣▶ P. 7 - 88
Central lubrication system – Checking the filling level	▣▣▣▣▶ P. 7 - 103
Other maintenance work – Checking the windscreen washing system	▣▣▣▣▶ P. 7 - 119















W

Maintenance work on the SUPERSTRUCTURE: Weekly	
Engine – General inspection	▣▣▣▣▶ P. 8 - 18
Hoists – Checking the oil level – General inspection – Checking the hoist brake	▣▣▣▣▶ P. 8 - 43 ▣▣▣▣▶ P. 8 - 44 ▣▣▣▣▶ P. 8 - 44
Slewing gear – Checking the oil level – Checking for leaks	▣▣▣▣▶ P. 8 - 49 ▣▣▣▣▶ P. 8 - 50
Pump transfer case – General inspection	▣▣▣▣▶ P. 8 - 65
Hydraulic system – Checking the hydraulic hoses – Checking the ventilation filter – Checking for leaks	▣▣▣▣▶ P. 8 - 70 ▣▣▣▣▶ P. 8 - 70 ▣▣▣▣▶ P. 8 - 71
Hoist ropes – Checking the hoist ropes	▣▣▣▣▶ P. 8 - 98
Central lubrication system – Checking the filling level	▣▣▣▣▶ P. 8 - 113
Other maintenance work – Checking the windscreen washing system	▣▣▣▣▶ P. 8 - 125

5.2.3

Maintenance plan M 1

M 1







Maintenance work on the CARRIER: monthly / after approx. 2,000 km (approx. 1 240 mi)	
Engine – Notes;  <i>Engine manufacturer's documentation</i>	 P. 7 - 11
Exhaust system with exhaust emission control – Check the exhaust system for external damage	 P. 7 - 37
Transfer case – Check the oil level	 P. 7 - 51
Axle lines – Axle centre drives – checking the oil level – Final drives – Checking the oil level – Lubricating the drive shafts in the axle lines	 P. 7 - 55  P. 7 - 59  P. 7 - 62
Wheels – Checking that the wheel nuts are tight	 P. 7 - 67
Suspension – Suspension struts – Checking the oil level – Suspension struts – checking the fastening	 P. 7 - 77  P. 7 - 78
Electrical system – Checking the batteries	 P. 7 - 108
Air-conditioning system – Checking the air-conditioning system	 P. 7 - 113
Other maintenance work – Lubricating the outrigger beams – Checking the functioning of the auxiliary heater	 P. 7 - 120  P. 7 - 121

Maintenance work on the SUPERSTRUCTURE: Monthly/after approx. 100 operating hours	
Engine – Notes; ■■■▶ <i>Engine manufacturer's documentation</i>	■■■■▶ P. 8 - 13
Exhaust system with exhaust emission control – Check the exhaust system for external damage	■■■■▶ P. 8 - 37
Pump transfer case – Check the oil level	■■■■▶ P. 8 - 65
Main boom – Grease the piston rod of the derricking cylinder	■■■■▶ P. 8 - 85
Electrical system – Checking the batteries	■■■■▶ P. 8 - 118
Air-conditioning system – Checking the air-conditioning system	■■■■▶ P. 8 - 121
Other maintenance work – Checking the functioning of the auxiliary heater	■■■■▶ P. 8 - 126

5.2.4

Maintenance plan M 3

M 3

Maintenance work on the CARRIER: every three months/after 5,000 - 6,000 km (3 100 - 3 730 mi)	
Engine – Notes;  <i>Engine manufacturer's documentation</i>	 P. 7 - 11
Vehicle brake – Checking brake lining thickness	 P. 7 - 73
Suspension – Forced lever – checking correct functioning	 P. 7 - 79
Hydraulic system – Cleaning the magnetic rods	 P. 7 - 89
Electrical system – Checking the charge level of the batteries – Charging the batteries using the battery charger	 P. 7 - 110  P. 7 - 112

Maintenance work on the SUPERSTRUCTURE: every three months/after 250 oper. hrs.	
Engine – Notes; ■■■► <i>Engine manufacturer's documentation</i>	■■■► P. 8 - 13
Slewing bearing – Checking the screws	■■■► P. 8 - 55
Hydraulic system – Oil filters 1 and 2 – cleaning the magnetic rod	■■■► P. 8 - 72
Main boom – Lubricating the locking pins – Lubricating the telescopic slide faces – Checking the sheaves	■■■► P. 8 - 86 ■■■► P. 8 - 89 ■■■► P. 8 - 94
Hoist ropes – Lubricating the hoist rope	■■■► P. 8 - 99
Hook blocks – Checking the sheaves	■■■► P. 8 - 115
Electrical system – Checking the charge level of the batteries – Charging the batteries using the battery charger	■■■► P. 8 - 118 ■■■► P. 8 - 119

5.2.5

Maintenance plan M 6

M 6

Maintenance work on the CARRIER: every six months / after 10,000 - 12,500 km (6 210 - 7 770 mi)	
Engine – Notes; ■■■► <i>Engine manufacturer's documentation</i> – Changing the oil and oil filter	■■■■► P. 7 - 11 ■■■■► P. 7 - 17
Fuel system – Replacing fuel filter 1 – Replacing fuel filter 2	■■■■► P. 7 - 30 ■■■■► P. 7 - 32
Transfer case – Changing the oil	■■■■► P. 7 - 52
Axle lines – Lubricating longitudinal drive shafts	■■■■► P. 7 - 63
Wheels – Changing the wheels	■■■■► P. 7 - 68
Air-conditioning system – Checking hoses	■■■■► P. 7 - 113

M 6

Maintenance work on the SUPERSTRUCTURE: every six months/after 500 oper. hrs.	
Engine – Notes; ■■■▶ <i>Engine manufacturer's documentation</i> – Changing the oil and the oil filter	■■■■▶ P. 8 - 13 ■■■■▶ P. 8 - 19
Fuel system – Replacing fuel filter 1 – Replacing fuel filter 2	■■■■▶ P. 8 - 29 ■■■■▶ P. 8 - 31
Hoists – Lubricating the auxiliary hoist	■■■■▶ P. 8 - 45
Slewing gear – Checking the slewing gear brake	■■■■▶ P. 8 - 50
Slewing bearing – Lubricating the gear teeth – General inspection – Measuring tilting play	■■■■▶ P. 8 - 59 ■■■■▶ P. 8 - 61 ■■■■▶ P. 8 - 62
Cable drums and slewing angle sensor – Maintenance of the slip ring assemblies	■■■■▶ P. 8 - 111
Air-conditioning system – Checking hoses	■■■■▶ P. 8 - 121

5.2.6

Maintenance plan M 12

M 12

Maintenance work on the CARRIER: every 12 months / after 20,000 - 25,000 km (12 430 - 15 530 mi)	
Engine – Notes; ■■■► <i>Engine manufacturer's documentation</i> – Have the radiator checked/cleaned – Changing the coolant – Changing the coolant cartridge	■■■► P. 7 - 11 ■■■► P. 7 - 19 ■■■► P. 7 - 23 ■■■► P. 7 - 25
Exhaust system with exhaust emission control – Having the AdBlue system checked – Having the soot particle filter system checked	■■■► P. 7 - 39 ■■■► P. 7 - 40
Axle lines – Axle centre drives – changing the oil – Final drives – Changing the oil	■■■► P. 7 - 57 ■■■► P. 7 - 60
Suspension – Pressure accumulator – checking the gas pressure	■■■► P. 7 - 80
Compressed air system – Replacing the filter cartridge of the compressed air drier	■■■► P. 7 - 85
Hydraulic system – Changing the ventilation filter – Taking oil samples: depending on the oil sample test results: – Changing the hydraulic oil – Changing the hydraulic oil filter	■■■► P. 7 - 91 ■■■► P. 7 - 92 ■■■► P. 7 - 97 ■■■► P. 7 - 101
Air-conditioning system – Cleaning the condenser fins – Checking the entire air-conditioning system – Changing the pollen filter	■■■► P. 7 - 114 ■■■► P. 7 - 114 ■■■► P. 7 - 116
Other maintenance work – Lubricating the cab door – Lubricating the connecting and socket pins – Renewing the corrosion protection	■■■► P. 7 - 121 ■■■► P. 7 - 122 ■■■► P. 7 - 123

M 12

Maintenance work on the SUPERSTRUCTURE: every 12 months/after 1,000 operating hours	
Engine – Notes; ■■■► <i>Engine manufacturer's documentation</i> – Have the radiator checked/cleaned – Changing the coolant	■■■■► P. 8 - 13 ■■■■► P. 8 - 21 ■■■■► P. 8 - 25
Exhaust system with exhaust emission control – Having the AdBlue system checked – Having the soot particle filter system checked	■■■■► P. 8 - 39 ■■■■► P. 8 - 40
Hoists – Changing the oil/checking the oil	■■■■► P. 8 - 46
Slewing gear – Changing the oil/checking the oil	■■■■► P. 8 - 52
Slewing bearing – Lubricating the locking of turntable	■■■■► P. 8 - 64
Pump transfer case – Changing the oil	■■■■► P. 8 - 66
Hydraulic system – Changing the ventilation filter – Pressure accumulator – checking the gas pressure – Taking oil samples: depending on the oil sample test results: – Changing the hydraulic oil – Changing the hydraulic oil filter	■■■■► P. 8 - 75 ■■■■► P. 8 - 76 ■■■■► P. 8 - 76 ■■■■► P. 8 - 82 ■■■■► P. 8 - 78
Main boom – Checking the locking system	■■■■► P. 8 - 95
Hook blocks – Greasing	■■■■► P. 8 - 115
Air-conditioning system – Cleaning the condenser fins – Checking the entire air-conditioning system	■■■■► P. 8 - 122 ■■■■► P. 8 - 122
Other maintenance work – Lubricating the crane cab door – Lubricating the connecting and socket pins – Renewing the corrosion protection	■■■■► P. 8 - 127 ■■■■► P. 8 - 128 ■■■■► P. 8 - 129

5.2.7

Maintenance plan Y 2

Y 2

Maintenance work on the CARRIER: every 24 months / after 40,000 – 50,000 km (25 000 – 31 000 mi)	
Engine – Notes; ■■■► <i>Engine manufacturer's documentation</i>	■■■■► P. 7 - 11
Transmission – Changing the oil and oil filter	■■■■► P. 7 - 47
Other maintenance work – Having the fire extinguisher checked	■■■■► P. 7 - 125

Maintenance work on the SUPERSTRUCTURE: every 24 months/after 2,000 oper. hrs.	
Engine – Notes; ■■■► <i>Engine manufacturer's documentation</i>	■■■■► P. 8 - 13
Other maintenance work – Having the fire extinguisher checked	■■■■► P. 8 - 131

5.2.8

Maintenance plan Y 3

Y 3

Maintenance work on the CARRIER: every 36 months	
Engine – Notes; ■■■▶ <i>Engine manufacturer's documentation</i>	■■■▶ P. 7 - 11

Maintenance work on the SUPERSTRUCTURE: every 36 months/after 3,000 oper. hrs.	
Engine – Notes; ■■■▶ <i>Engine manufacturer's documentation</i>	■■■▶ P. 8 - 13
Hoists – Having a partial inspection carried out	■■■▶ P. 8 - 48

5.2.9

Maintenance plan Y 5

Y 5

Maintenance work on the CARRIER: every 60 months / 100,000 km (62 000 mi)	
Engine – Notes; ■■■▶ <i>Engine manufacturer's documentation</i>	■■■▶ P. 7 - 11
– Have the Cardan shaft between the transmission on the engine and the transfer case replaced by Manitowoc Crane Care or an authorised GROVE dealer.	

Maintenance work on the SUPERSTRUCTURE: every 60 months/after 5,000 oper. hrs.	
Engine – Notes; ■■■▶ <i>Engine manufacturer's documentation</i>	■■■▶ P. 8 - 13

5.2.10

Maintenance plan Y 6

Y 6

Maintenance work on the CARRIER: every 72 months	
Engine – Notes; ■■■▶ <i>Engine manufacturer's documentation</i>	■■■▶ P. 7 - 11

Maintenance work on the SUPERSTRUCTURE: every 72 months/after 6,000 oper. hrs.	
Engine – Notes; ■■■▶ <i>Engine manufacturer's documentation</i>	■■■▶ P. 8 - 13
Hoists – Having a general inspection carried out	■■■▶ P. 8 - 48

5.2.11

Maintenance plan Y 10

Y 10

Maintenance work on the CARRIER: every 120 months/after 200,000 km (124 000 mi)	
Steel construction – Check the load-bearing steel fabrication. For further information, please contact Manitowoc Crane Care .	

Maintenance work on the SUPERSTRUCTURE: every 120 months/after 12,000 oper. hrs.	
Steel construction – Check the load-bearing steel fabrication. For further information, please contact Manitowoc Crane Care .	
Rated capacity limiter (RCL) – Have the RCL checked by Manitowoc Crane Care .	

5.3

Periodic inspections

Your GMK7450 truck crane has been inspected before delivery.

- Truck cranes used in Germany are inspected in accordance with the regulations of the professional trade association as defined by DGUV Regulation 52 (BGV D 6) .
- Truck cranes that are to be used abroad are inspected in accordance with the regulations of the respective country. If such regulations do not exist, they are inspected in accordance with the regulations of the professional trade association as defined by DGUV Regulation 52 (BGV D 6).

According to German regulations (DGUV), an inspection must be carried out once a year. The regulations in other countries may prescribe different inspection intervals. If such regulations do not exist, an inspection should be carried out by an *expert* at least once a year.

These periodic inspections are generally visual examinations intended to assess the condition of the truck crane and its components. Their purpose is to detect defects at an early stage and thus prevent accidents.

Inspections must be carried out on the following, if they are not already included in the list of periodic maintenance work:

- the hydraulic and electrical control and safety devices,
- the rated capacity limiter (RCL),
- the fastening and safety devices of all screwed-on parts,
- the hoist ropes,
- the load hooks (▣▣▣▣► *Load hook inspection*, P. 5 - 20),
- the load-bearing structural steelwork (for tears, deformations, etc.), including a special check of all welds.

If damage is found on the steel fabrication, qualified specialists must determine the extent of the damage using the required material examination methods. They should then determine what sort of repair should be carried out.

Prior to carrying out welding work on the truck crane, observe the ▣▣▣▣► *Safety instructions for welding work*, P. 1 - 4.

The inspector must write a report containing the result of the annual inspection that was performed and the measures taken to repair any damage.

5.3.1 Load hook inspection

The hook opening on the load hooks must be checked regularly for deformation.

The hook opening must not have increased by more than 10% of the original dimensions y , $y1$, $y2$.

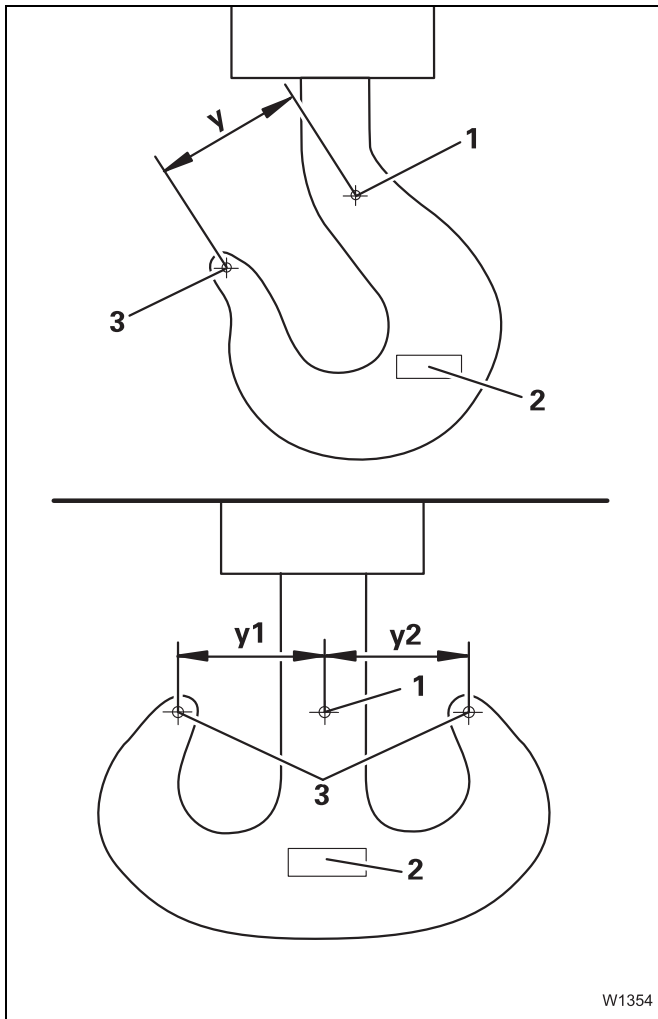

The original dimensions y , $y1$, $y2$ are specified in field (2) on the load hooks.

- To check this, measure the distance between the marked measuring points on the load hook shaft (1) and the tip of the hook (3).

The hook block may no longer be used if the opening has increased by more than 10% of its original dimension.



Risk of accidents due to the load falling!

Hook blocks with deformed load hooks are no longer safe to use. The load hooks could break and drop the load.

Deformed load hooks must always be replaced!

The actual service life of a winch is affected by a number of additional external factors, such as:

1. Overloading caused by improper use of the truck crane.
2. Insufficient maintenance: Oil is not changed at the specified intervals.
3. Operating errors: Extreme acceleration or deceleration of the load, load drops and stops suddenly while suspended.
4. Improper maintenance: Wrong oil used, incorrect filling quantity, contamination during oil change.
5. Improper assembly during maintenance and repair work.
6. Leaks which were ignored.
7. Improper adjustment of safety devices.
8. Concealed damage caused by accidents.
9. Extreme environmental conditions: Low or high temperatures, aggressive atmosphere, dust and dirt.

5.4.2

Proportion of theoretical service life used

The truck crane operator must perform a truck crane inspection at least once a year (ISO 9927-1 and DGUV Regulation 52 (BGV D 6) / DGUV Regulation 54 (BGV D 8)).

This includes determining the proportion of theoretical service life that has been used. If required, the truck crane operator has to appoint an approved inspector for this assessment.

The actual operating conditions (load spectrum) and the hoist operating hours must be determined for each inspection interval when determining the proportion of theoretical service life that has been used. The operator is responsible for proper documentation in the crane logbook.

Determining the operating conditions (load spectrum)

The truck crane's load spectrum is divided into groups (see also ISO 4301/1, FEM 1.001):



When determining the load spectrum, the existing rope pull is used as the standard, i.e. under certain circumstances, the truck crane can be supporting a small load, whereby the winch is actually supporting a heavy load, e.g. due to insufficient reeving. Therefore, the following graphic representation of the load spectrum refers to the winch's wire cables.

Load spectrum class	Definition	Proportions of the running time	Factor of the load-spectrum $K_m =$	Graphic representation
Light Q 1 L 1	Power units or parts thereof that are subject to high stress in exceptional situations, but which are generally subject to only low stress	10% of the running time with greatest load (dead load + 1/1 payload) 40% of the running time with dead load + 1/3 payload 50% of the running time with dead load	0.125	
Medium Q 2 L 2	Power unit or parts thereof that are subject to high stress quite often, but which are generally subject to only minimal stress	1/6 of the running time with greatest load (dead load + 1/1 payload) 1/6 of the running time with dead load + 2/3 payload 1/6 of the running time with dead load + 1/3 payload 50% of the running time with dead load	0.25	
heavy Q 3 L 3	Power units or parts thereof that are subject to high stress frequently and medium stress continuously	50% of the running time with greatest load (dead load + 1/1 payload) 50% of the running time with dead load	0.5	
very heavy Q 4 L 4	Power unit or parts thereof that are regularly subjected to high stress from neighbouring stress sources	90% of the running time with greatest load (dead load + 1/1 payload) 10% of the running time with dead load	1	

16.08.2018



One of the load spectrums listed above should be selected on the basis of the actual operating conditions and entered in the crane logbook for the respective testing interval.

Note for truck cranes:

The load spectrum L1 and the factor of the load spectrum $K_m = 0.125$ are generally applied to truck cranes in assembly mode.

Determining the effective operating hours T_i

The effective winch operating hours must be entered in the crane logbook for the respective inspection interval.

- The effective winch operating hours T_i displayed in the *Operating hours submenu*;  *Operating manual*.

Determining the proportion of theoretical service life used

For an inspection interval i (max. 1 year according to ISO 9927-1 or DGUV Regulation 52 (BGV D 6) / DGUV Regulation 54 (BGV D 8)), the proportion of theoretical service life used S_i is calculated using the formula:

$$S_i = \frac{K_{m_i}}{K_m} \times T_i$$

K_m = Factor of the load spectrum used as the basis for winch calculation. This factor is given in the operating manual.

K_{m_i} = Factor of the load spectrum in inspection interval i in accordance with the section "Determining the operating conditions (load spectrum)"

T_i = Effective operating hours in the testing interval i as described in the section "Determining the actual operating hours T_i "

This used proportion is subtracted from the remaining theoretical service life D_i after every inspection interval (see example in the appendix to this chapter).

If the remaining theoretical service life is not sufficient for the next operating period, then a general overhaul of the winch must be performed.

If theoretical service life D has been reached ( *Theoretical service life*, P. 5 - 21), the winch must not be operated until after a general overhaul has been performed.

A general overhaul must always be performed at least once every 10 years after putting the truck crane into operation.

The general overhaul is to be arranged by the operator and performed by the manufacturer or a representative authorised by the manufacturer. The results are to be entered in the crane logbook.

The manufacturer or an authorised representative will specify a new theoretical service life D upon completion of the general overhaul.

The next general overhaul must be performed within 10 years at the latest.

Alternative provision

If after 10 years the theoretical service life has not been used up the winch can continue to be operated without a general overhaul under the following conditions:

The crane expert has confirmed that the used proportion of the service life is correct and useful by signing his/her name in the crane test book after every inspection.

In this case the crane inspector must closely inspect the winch. This includes at least:

- a visual examination of the exterior (for leaks, damage, deformation etc.),
- an oil inspection (especially for metallic residues),
- a load inspection with minimum and maximum rope pull and each at maximum possible speed. At least one layer must be wound. Investigate any unusual noises during the load inspection.

This inspection must be confirmed in the crane logbook by the approved crane inspector and there must be a statement on continued operation for the winch. The next inspection occurs before expiry of the 12th operating year and must be repeated annually after this.

5.4.3

Example

A GMK7450 is equipped with a separate operating hours counter for the hoist and is classified by **Manitowoc Crane Group Germany GmbH** as follows:

Power unit group:	M 3
Load spectrum:	light L1, $K_m = 0.125$
Theoretical service life:	$D = 3,200$ h

The used proportion S of theoretical service life is calculated based on the individual inspection intervals as follows:

1st Inspection (1st year)

The truck crane was used for assembly work during the previous year: Load spectrum L 1, i.e. $K_{m1} = 0.125$.

The operating hours counter for the main hoist reads 160 h, i.e. $T_1 = 160$ h.

The used proportion S_1 of theoretical service life after the first inspection therefore is: Inspection:

$$S_i = \frac{0,125}{0,125} \times 160 \text{ h} = 160 \text{ h}$$

Remaining theoretical service life:

$$D_1 = 3,200 \text{ h} - 160 \text{ h} = 3,040 \text{ h.}$$

The aforementioned values are entered in the table (see table example p. 5 - 28).

2nd inspection (2nd year)

The truck crane was used for unloading work on docks: Load spectrum: L 3, i.e. $K_{m2} = 0.5$.

The operating hours counter for the main hoist reads 640 h, i.e. during this period: $640 \text{ hrs.} - 160 \text{ hrs.} = 480 \text{ hrs.}$ (160 hrs. were used during the first year)
 $T_2 = 480 \text{ hrs.}$

The used proportion S_2 of theoretical service life after the 2nd inspection is therefore:

$$S_i = \frac{0,5}{0,125} \times 480 \text{ h} = 1920 \text{ h}$$

Remaining theoretical service life:

$$D2 = 3,040 \text{ h} - 1,920 \text{ h} = 1,120 \text{ h}.$$

The aforementioned values are entered in the table (see table example p. 5 - 28).

3rd inspection (3rd year)

The truck crane was used for assembly work and occasional unloading work on docks: Load spectrum: L 2, i.e. $Km_3 = 0.25$.

The operating hours counter for the main hoist reads 940 h, i.e. during this period: $940 \text{ h} - 640 \text{ h} = 300 \text{ h}$. $T3 = 300 \text{ h}$.

The used proportion $S3$ of theoretical service life after the 3rd inspection is therefore:

$$S_i = \frac{0,25}{0,125} \times 300 \text{ h} = 600 \text{ h}$$

Remaining theoretical service life:

$$D3 = 1,120 \text{ h} - 600 \text{ h} = 520 \text{ h}.$$

The values are entered in the table (see table example p. 5 - 28).

The remaining theoretical service life is to be documented in a separate table for each winch.

This table is to be attached to the crane logbook. This table is to be found in the maintenance manual's appendix for truck cranes that do not require a crane logbook or similar documentation according to the regulations in the country in which you are working.



Sample table to determine the remaining theoretical service life on winch no. 1 (main hoist winch)

Crane type: GMK 3045
 Work number: 3045 42 06
 Initial commissioning: 10. 06. 1990
 Serial number of the winch in accordance with the model plate: 13 301
 Last general overhaul performed on:

Winch design data (see operating manual):
 Engine group: M 3
 Load spectrum: Q 1 (L1)
 Factor of the load spectrum: Km = 0.125
 Theoretical service life: D = 3,200 h

Inspection interval no. (max. 1 year)	Date of first commissioning/date of inspection	Operating conditions since the last inspection	Factor of the load spectrum	Operating hours of the entire crane	Operating hours of the superstructure	Operating hours of the superstructure since the last inspection	Winch operating hours	Operating hours T_1 of the winch since the last inspection	Used proportion S_i of theoretical service life D :	Remaining theoretical service life $D_i = D - S_i$	Name of the expert	Signature	Comment	Name of the approved inspector	Signature
0(*)	10. 6. 90	-	-	-	-	-	-	-	0	3,200					
1	5. 6. 91	L 1	0.125	-	-	-	160	160	160	3,040	Müller				
2	20. 5. 92	L 3	0.5	-	-	-	640	480	1,920	1,120	Huber				
3	18. 5. 93	L 2	0.25	-	-	-	940	300	600	520	Schmitz				

CAUTION:
A general overhaul is to be performed every 10 years!

For alternative provision, refer to section 5.4.2, p. 5 - 25.

General overhaul performed on.....

S_i = Used proportion of theoretical service life since the last inspection
 D_i = Remaining theoretical service life
 D_{i-1} = Remaining theoretical service life after the previous inspection
 K_m = Factor of the load spectrum used to calculate the winch.
 This factor is given in the operating manual.
 K_{m1} = Factor of the load spectrum in the inspection interval "1" according to section 2.1
 T_1 = Effective operating hours in the inspection interval "1" according to section 2.2
 (*) Copy the last line of the previous page to the following page.

6 Lubricants and consumables

6.1	Lubricants	6 - 1
6.1.1	Lubricants list	6 - 2
6.1.2	Lubricant applications list	6 - 3
6.2	Refrigerant	6 - 5
6.3	Consumables	6 - 5
6.3.1	Fuel	6 - 5
6.3.2	Engine coolant admixtures	6 - 5
6.3.3	After-treatment of exhaust gases	6 - 6
6.3.4	Windscreen washing system admixtures	6 - 6
6.3.5	Fuel for crane cab heating system	6 - 6

6

Lubricants and consumables

6.1

Lubricants

All lubricants that you require for

- *Maintenance work on the carrier, p. 7 - 1* and
- *Maintenance work on the superstructure, p. 8 - 1*

are listed with serial numbers in the lubricants list and the lubricant applications list.

▣▣▣▣▶ *Lubricants list, P. 6 - 2.*

▣▣▣▣▶ *Lubricant applications list, P. 6 - 3.*

6.1.1

Lubricants list

Consec. no.	GROVE- Part number	Lubricant type	Designation to DIN 51502	Specification classification	Viscosity
1	04162428	Engine oil	HD - CD	CES 20081 Cummins	SAE 15 W-40
2	6829101690	Gear oil		TranSynd TE295 C4-27403598	synthetic
3	00552891	Gear oil	C - LPF	MIL-L 2105 B API-GL-5	Hyp SAE 90 ISO - VG 220
4	02310863	Gear oil		Rivolta S.K.D. 170	
5	02313611	Gear oil	C - LPF	MIL-L 2105 B API-GL-4/5 (synthetic)	SAE 75 W-90 EP ISO - VG 220
6	00554217	Gear oil	C - LPF	Aral Degol BG 220 MIL-L 2105 C	SAE 90 ISO - VG 220
7	04162158	Hydraulic oil	HVLP	Castrol Hyspin AWH-M 32 DIN 51524-3	ISO - VG 32
8	03233369	Lubricating grease	KP - 1K - 50	DIN 51825 Renolit JP 1619	- 50 °C to +120 °C (-58 °F to +248 °F)
9	00554205	Spray		Ceplattyn 300	
10	02314698	Slide paste		PAL 1	
11	03325215	Lubricating grease		RHUS SW 2	
12	01929824	Spray		Berulub spray	
13	03133770	Lubricating grease		Elaskon 30	

6.1.2 Lubricant applications list

Consec. no.	Lubricant type	Usage	Fill quantity in litres (gal)	Maintenance interval
1	Engine oil	Diesel engine for carrier; ■■■► P. 7 - 17	53 (14.0)	M 6
		Diesel engine for superstructure; ■■■► P. 8 - 19	17 (4.5)	M 6
2	Gear oil	Transmission; ■■■► P. 7 - 47	51 (13.5)	Y 2
3	Gear oil	with 14 x 6 drive: Transfer case; ■■■► P. 7 - 52	12.8 (3.4)	M 6
		with 14 x 8 drive: Transfer case; ■■■► P. 7 - 52	11.8 (3.1)	M 6
		1st axle line axle centre drive; ■■■► P. 7 - 57	13.0 (3.5)	M 12
		5th axle line axle centre drive; ■■■► P. 7 - 57	13.0 (3.5)	M 12
		4th axle line axle centre drive; ■■■► P. 7 - 57	16.5 (4.4)	M 12
		only for 14 x 8 x 14 drive: 2nd axle line axle centre drive; ■■■► P. 7 - 57	16.5 (4.4)	M 12
		6 or 8 x final drives; ■■■► P. 7 - 60	2.7 (0.7)	M 12
4	Gear oil	6 x suspension struts; ■■■► P. 7 - 77	1.5 (0.4)	M 1
		8 x suspension struts; ■■■► P. 7 - 77	3.2 (0.84)	M 1
5	Gear oil	2 x hoists; ■■■► P. 8 - 46	11.5 (3.0)	M 12
		3 x slewing gears; ■■■► P. 8 - 52	0.9 (0.24)	M 12
6	Gear oil	Pump transfer case; ■■■► P. 8 - 66	3.8 (1.0)	M 12
7	Hydraulic oil	Carrier hydraulic tank; ■■■► P. 7 - 97	200 (53)	M 12
		Superstructure hydraulic tank; ■■■► P. 8 - 82	1,780 (470)	M 12



Consec. no.	Lubricant type	Usage	Fill quantity in litres (gal)	Maintenance interval
8	Lubricating grease	Carrier central lubrication; ■■■▶ P. 7 - 103		W
		Superstructure central lubrication; ■■■▶ P. 8 - 113		W
		Cardan shafts – transverse; ■■■▶ P. 7 - 62		M 1
		Cardan shafts – longitudinal; ■■■▶ P. 7 - 63		M 6
		Outrigger beams; ■■■▶ P. 7 - 120		M 1
		Auxiliary hoist; ■■■▶ P. 8 - 45		M 6
		Turntable lock; ■■■▶ P. 8 - 64		M 12
		Hook blocks; ■■■▶ P. 8 - 115		M 12
		Cab door hinges; ■■■▶ P. 7 - 121		M 12
		Carrier pins; ■■■▶ P. 7 - 122		M 12
		Superstructure pins; ■■■▶ P. 8 - 128		M 12
9	Spray	Slewing bearing gear teeth; ■■■▶ P. 8 - 59		M 6
10	Slide paste	Telescope slide faces; ■■■▶ P. 8 - 89		M 3
11	Lubricating grease	Derricking cylinder piston rod; ■■■▶ P. 8 - 85		M 1
		Cab door rails; ■■■▶ P. 8 - 127		M 12
12	Spray	Outrigger pad/supporting cylinder; ■■■▶ P. 7 - 120		M 1
		Derricking cylinder piston rod; ■■■▶ P. 8 - 85		M 1
		Boom locking pin; ■■■▶ P. 8 - 86		M 3
13	Lubricating grease	Lubricating the hoist ropes; ■■■▶ P. 8 - 99		M 3

6.2 Refrigerant

Refrigerant Designation	Usage	Fill quantity in kg (lbs)	Maintenance interval
Tetrafluoroethane (R134a) CAS no. 811-97-2 EC no. 212-377-0	Air-conditioning system in the driver's cab; ▣▣▣▣▶ P. 7 - 114	1.25 (2.75)	M 12
	Air-conditioning system in the crane cab; ▣▣▣▣▶ P. 8 - 122	1.45 (3.20)	M 12

6.3 Consumables

6.3.1 Fuel

The fuels to be used and their respective specifications can be found in the *Engine manufacturer's documentation*.

- Also observe the **signs** on the diesel tank of the truck crane:
"The **use of additives is not permitted** and can damage the engine system."

6.3.2 Engine coolant admixtures

The specifications and admixture ratios can be found in the *Engine manufacturer's documentation*.

The coolant must be replaced annually (**M 12**);
▣▣▣▣▶ *Engine manufacturer's documentation*.

6.3.3 After-treatment of exhaust gases

Designation	Usage	Fill quantity in litres (gal)
DEF (Diesel Exhaust Fluid) ¹⁾ <i>AdBlue</i> : GROVE part number: 03140555	AdBlue tank on the carrier; ▣▣▣▣▶ P. 7 - 36	56.8 (15)
	AdBlue tank on the superstructure; ▣▣▣▣▶ P. 8 - 36	37.8 (10)

- ¹⁾ DEF (Diesel Exhaust Fluid),
Consumable for exhaust gas emission control, e.g. *AdBlue*.
For *AdBlue* there are registered trademarks of the following companies
- Kruse GmbH & Co KG,
 - BASF SE,
 - and of the Association of the Automotive Industry e.V.

6.3.4 Windscreen washing system admixtures

Commercial cleansers and antifreeze may be added to the windscreen washing water. Observe the application instructions on the packaging.

6.3.5 Fuel for crane cab heating system

Only if the truck crane is fitted with a separate tank for the auxiliary heater do you have the option of selecting whether to use the same fuel as in Section 6.3.1 or to use EL heating oil.

7	Maintenance work on the carrier	
7.1	General instructions	7 - 1
7.1.1	Covers	7 - 1
7.1.2	Overview of maintenance work on the carrier	7 - 2
7.2	Symbols for maintenance work	7 - 9
7.3	Engine	7 - 11
7.3.1	Check the oil level	7 - 11
7.3.2	Topping up the oil	7 - 13
7.3.3	Checking the air filter	7 - 14
7.3.4	Checking the coolant level	7 - 15
7.3.5	General inspection	7 - 16
7.3.6	Changing the oil and oil filter	7 - 17
7.3.7	Have the radiator checked/cleaned	7 - 19
7.3.8	Changing the coolant	7 - 23
7.3.9	Changing the coolant cartridge	7 - 25
7.4	Fuel system	7 - 27
7.4.1	Checking fuel filter 1	7 - 28
7.4.2	Draining off water from fuel filter 1	7 - 29
7.4.3	Replacing fuel filter 1	7 - 30
7.4.4	Replacing fuel filter 2	7 - 32
7.5	Exhaust system with exhaust emission control	7 - 35
7.5.1	Checking the AdBlue tank level	7 - 36
7.5.2	Filling up with AdBlue	7 - 36
7.5.3	Check the exhaust system for external damage	7 - 37
7.5.4	Having the AdBlue system checked	7 - 39
7.5.5	Having the soot particle filter system checked	7 - 40
7.6	Transmission	7 - 43
7.6.1	Check the oil level	7 - 43
7.6.2	General inspection	7 - 47
7.6.3	Changing the oil and oil filter	7 - 47
7.7	Transfer case	7 - 51
7.7.1	General inspection	7 - 51
7.7.2	Check the oil level	7 - 51
7.7.3	Changing the oil	7 - 52
7.8	Axle lines	7 - 55
7.8.1	General inspection	7 - 55
7.8.2	Axle centre drives – checking the oil level	7 - 55
7.8.3	Axle centre drives – changing the oil	7 - 57
7.8.4	Final drives – Checking the oil level	7 - 59
7.8.5	Final drives – Changing the oil	7 - 60
7.8.6	Lubricating the drive shafts in the axle lines	7 - 62
7.8.7	Lubricating longitudinal drive shafts	7 - 63
7.9	Wheels	7 - 65
7.9.1	Checking the tyres for damage	7 - 65

7.9.2	Checking the tyre pressure	7 - 66
7.9.3	Checking that the wheel nuts are tight	7 - 67
7.9.4	Changing the wheels	7 - 68
7.10	Vehicle brake	7 - 73
7.10.1	Checking brake lining thickness	7 - 73
7.11	Suspension.	7 - 77
7.11.1	Suspension struts – Checking the oil level	7 - 77
7.11.2	Suspension struts – checking the fastening	7 - 78
7.11.3	Forced lever – checking correct functioning	7 - 79
7.11.4	Pressure accumulator – checking the gas pressure	7 - 80
7.12	Steering	7 - 81
7.12.1	Checking for leaks	7 - 81
7.13	Compressed air system.	7 - 83
7.13.1	Draining water from the compressed air system	7 - 83
7.13.2	Checking for leaks	7 - 84
7.13.3	Replacing the filter cartridge of the compressed air drier	7 - 85
7.14	Hydraulic system	7 - 87
7.14.1	Check the oil level	7 - 87
7.14.2	Checking the hydraulic hoses	7 - 88
7.14.3	Checking for leaks	7 - 88
7.14.4	Cleaning the magnetic rods	7 - 89
7.14.5	Changing the ventilation filter	7 - 91
7.14.6	Taking oil samples	7 - 92
7.14.7	Changing the hydraulic oil	7 - 97
7.14.8	Changing the hydraulic oil filter	7 - 101
7.15	Central lubrication system	7 - 103
7.15.1	Checking the filling level	7 - 103
7.15.2	Bleeding the central lubrication system.	7 - 105
7.15.3	Triggering intermediate lubrication	7 - 105
7.16	Electrical system	7 - 107
7.16.1	Checking the lighting and indicators	7 - 107
7.16.2	Checking the batteries	7 - 108
7.16.3	Checking the charge level of the batteries	7 - 110
7.16.4	Charging the batteries using the battery charger	7 - 112
7.17	Air-conditioning system	7 - 113
7.17.1	Checking the air-conditioning system	7 - 113
7.17.2	Checking hoses	7 - 113
7.17.3	Cleaning the condenser fins	7 - 114
7.17.4	Checking the entire air-conditioning system	7 - 114
7.17.5	Changing the pollen filter	7 - 116
7.18	Other maintenance work	7 - 119
7.18.1	Checking the windscreen washing system	7 - 119
7.18.2	Lubricating the outrigger beams	7 - 120
7.18.3	Checking the functioning of the auxiliary heater	7 - 121
7.18.4	Lubricating the cab door	7 - 121

7.18.5	Lubricating the connecting and socket pins	7 - 122
7.18.6	Renewing the corrosion protection	7 - 123
7.18.7	Having the fire extinguisher checked	7 - 125

7

Maintenance work on the carrier

7.1

General instructions

7.1.1

Covers

Various types of work (e.g. oil change) require that covers be removed.

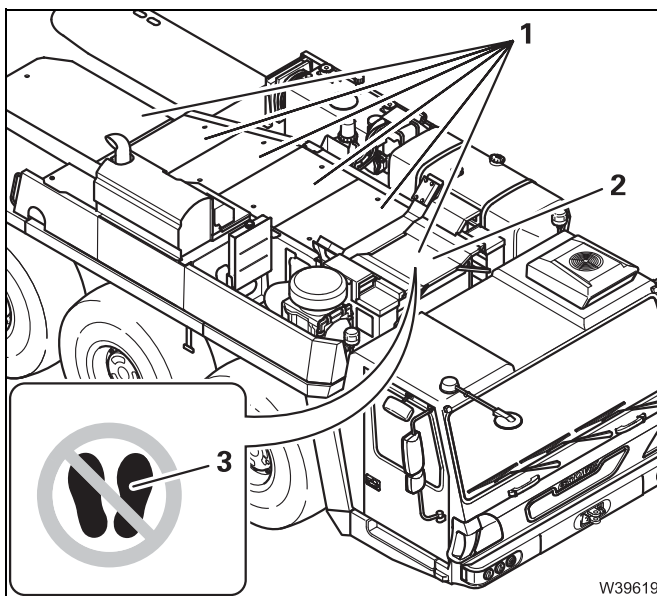

Before maintenance work

- Remove the covers (1).

After maintenance work

- Fasten the covers (1) with the locks.



Risk of damage to the radiator!

A radiator that can be damaged is located under the cover (2). Therefore, do not walk on the cover (2). Observe the label (3) on the cover. Remove the cover (2) only when performing maintenance work on the radiator;  Have the radiator checked/cleaned, P. 7 - 19.

7.1.2

Overview of maintenance work on the carrier

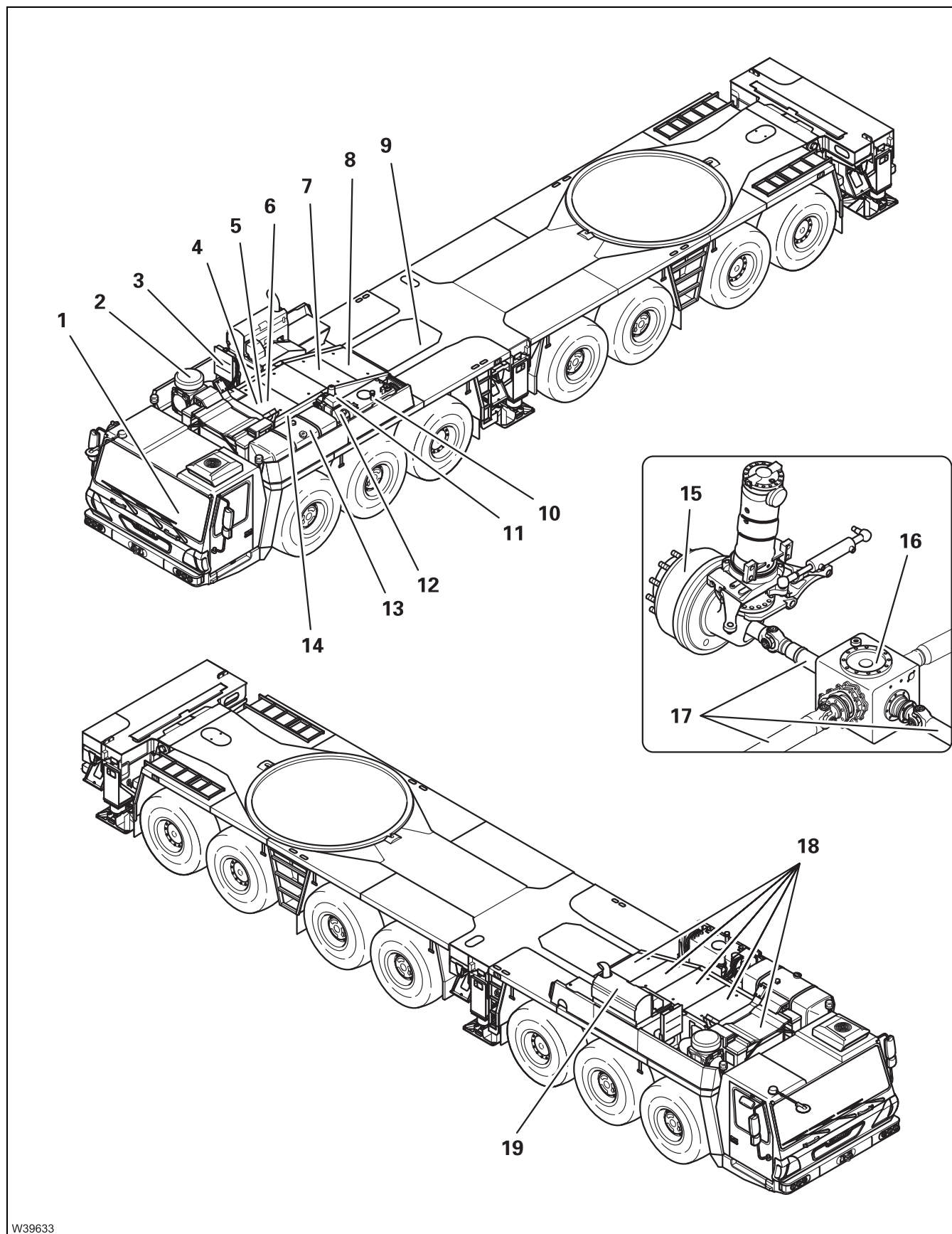

W39633

16.08.2018

Symbols for maintenance work

	▣▣▣▣➔	P. 7 - 9
1 Instrument panel	▣▣▣▣➔	P. 7 - 9
Engine	▣▣▣▣➔	P. 7 - 11
6 Diesel engine	▣▣▣▣➔	P. 7 - 11
18 Covers	▣▣▣▣➔	P. 7 - 1
14 Dipstick	▣▣▣▣➔	P. 7 - 11
4 Oil filler opening	▣▣▣▣➔	P. 7 - 13
2 Air filter	▣▣▣▣➔	P. 7 - 14
3 Coolant reservoir	▣▣▣▣➔	P. 7 - 15
5 Oil filter	▣▣▣▣➔	P. 7 - 17
Fuel system	▣▣▣▣➔	P. 7 - 27
13 Diesel tank	▣▣▣▣➔	P. 7 - 27
10 Filter 1	▣▣▣▣➔	P. 7 - 28
11 Filter 2	▣▣▣▣➔	P. 7 - 32
Exhaust system with exhaust emission control	▣▣▣▣➔	P. 7 - 35
12 AdBlue tank	▣▣▣▣➔	P. 7 - 36
19 Exhaust silencer with filter and catalytic converter	▣▣▣▣➔	P. 7 - 37
Transmission	▣▣▣▣➔	P. 7 - 43
7 Dipstick	▣▣▣▣➔	P. 7 - 43
8 Oil filter	▣▣▣▣➔	P. 7 - 47
Transfer case	▣▣▣▣➔	P. 7 - 51
9 Oil level plug	▣▣▣▣➔	P. 7 - 52
Axle lines	▣▣▣▣➔	P. 7 - 55
16 Axle centre drives	▣▣▣▣➔	P. 7 - 55
15 Final drives	▣▣▣▣➔	P. 7 - 59
17 Cardan shafts	▣▣▣▣➔	P. 7 - 62



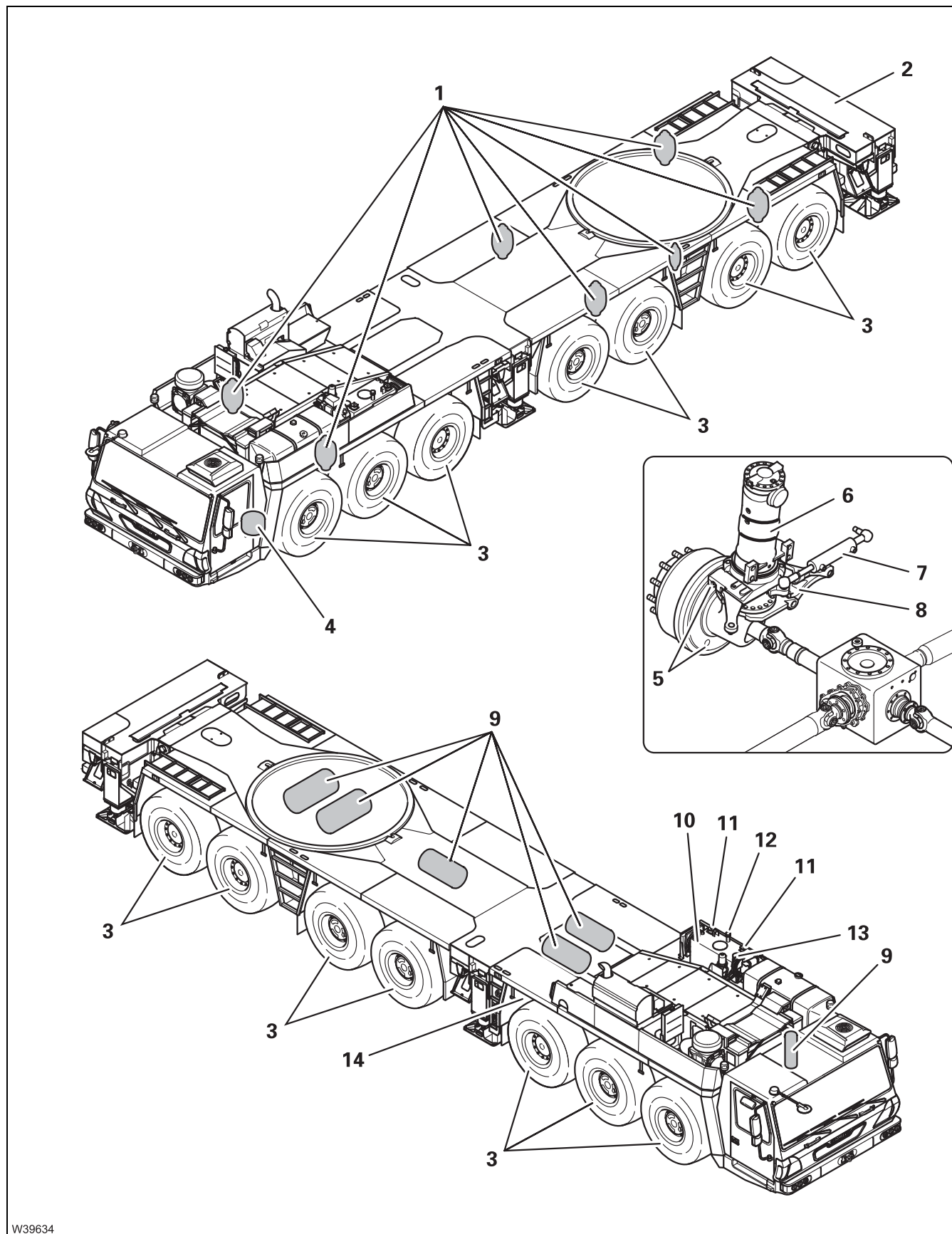

W39634

16.08.2018

Wheels	▣▣▣▣▶ P. 7 - 65
3 Wheels	▣▣▣▣▶ P. 7 - 65
2 Removable Outrigger Box (ROB)	
Vehicle brake	▣▣▣▣▶ P. 7 - 73
5 Brake linings	▣▣▣▣▶ P. 7 - 73
Suspension	▣▣▣▣▶ P. 7 - 77
6 Suspension struts	▣▣▣▣▶ P. 7 - 77
8 Forced lever	▣▣▣▣▶ P. 7 - 79
1 Pressure accumulator	▣▣▣▣▶ P. 7 - 80
Steering	▣▣▣▣▶ P. 7 - 81
7 Steering cylinder	▣▣▣▣▶ P. 7 - 81
Compressed air system	▣▣▣▣▶ P. 7 - 83
9 Receptacle	▣▣▣▣▶ P. 7 - 83
4 Drier	▣▣▣▣▶ P. 7 - 85
Hydraulic system	▣▣▣▣▶ P. 7 - 87
10 Oil tank with sight glass	▣▣▣▣▶ P. 7 - 87
11 Oil filters 1 and 2	▣▣▣▣▶ P. 7 - 102
12 Ventilation filter	▣▣▣▣▶ P. 7 - 91
13 Oil filler opening	▣▣▣▣▶ P. 7 - 99
Central lubrication system	▣▣▣▣▶ P. 7 - 103
14 Centralized lubrication pump	▣▣▣▣▶ P. 7 - 103



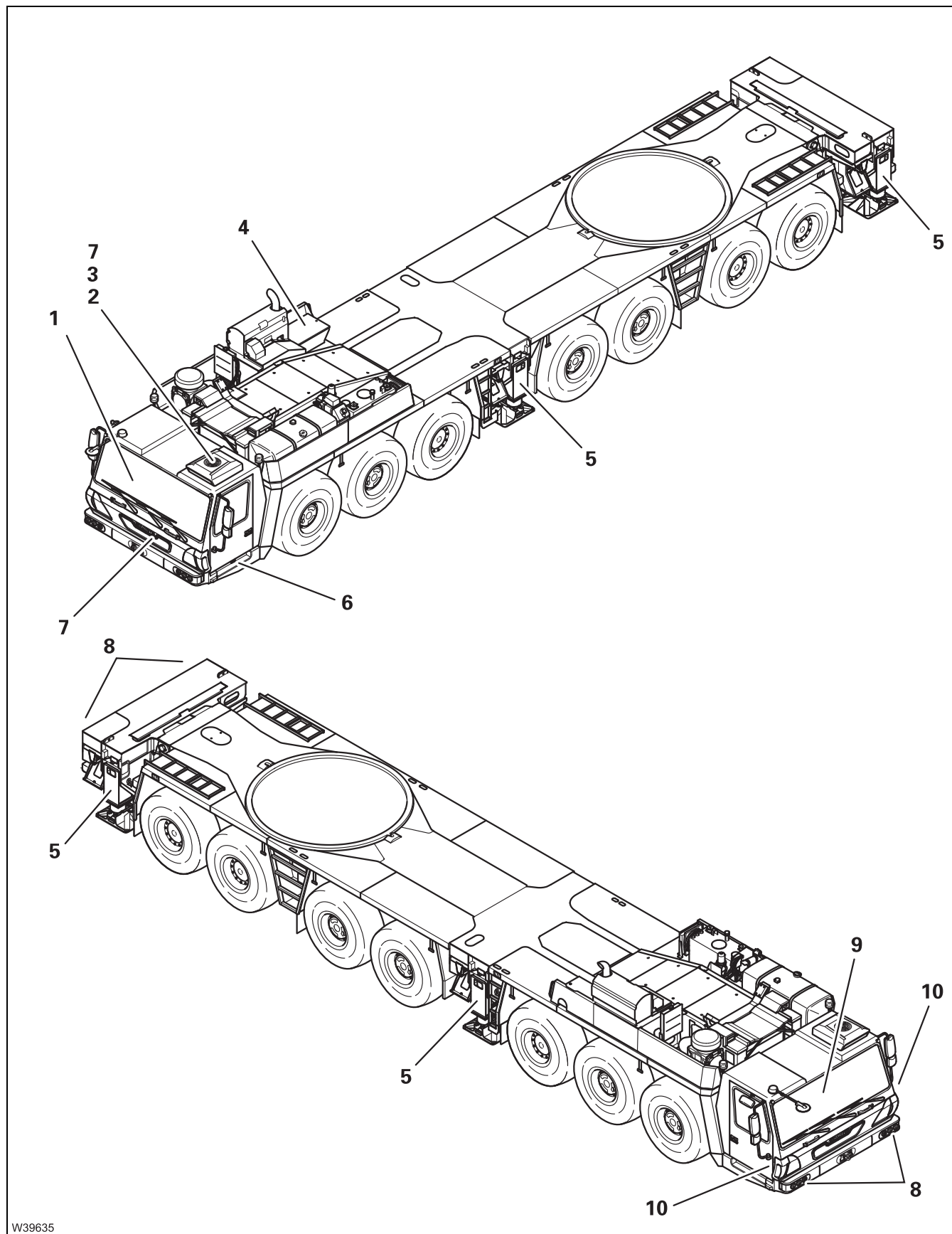

W39635

16.08.2018

Electrical system	▣▣▣▣▶ P. 7 - 107
8 Carrier lighting	▣▣▣▣▶ P. 7 - 107
4 Battery box	▣▣▣▣▶ P. 7 - 108
Air-conditioning system	▣▣▣▣▶ P. 7 - 113
2 Air-conditioning system in the driver's cab	▣▣▣▣▶ P. 7 - 113
3 Condenser fins	▣▣▣▣▶ P. 7 - 114
7 Pollen filter	▣▣▣▣▶ P. 7 - 116
Other maintenance work	▣▣▣▣▶ P. 7 - 119
6 Windscreen washing system reservoir	▣▣▣▣▶ P. 7 - 119
5 Outrigger beams	▣▣▣▣▶ P. 7 - 120
1 Driver's cab auxiliary heater ¹⁾	▣▣▣▣▶ P. 7 - 121
10 Cab door hinges	▣▣▣▣▶ P. 7 - 121
– Various connecting pins and socket pins	▣▣▣▣▶ P. 7 - 122
– Corrosion protection	▣▣▣▣▶ P. 7 - 123
9 Fire extinguisher	▣▣▣▣▶ P. 7 - 125

¹⁾ Additional equipment

Blank page

7.2

Symbols for maintenance work

Check the following lamps daily before starting operations.

On the instrument panel

If one of the lamps on the instrument panel in the driver's cab is lit you must carry out the corresponding maintenance work:

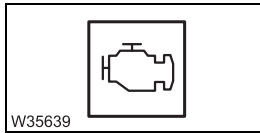

– Engine malfunction; P. 7 - 11,

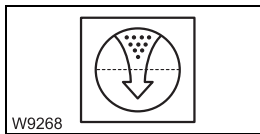

– Air filter; P. 7 - 14,



– Coolant level; P. 7 - 15,



– AdBlue system; P. 7 - 36,

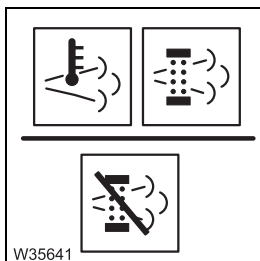

– Exhaust gas temperature and exhaust gas regeneration; P. 7 - 40,



– Transmission malfunction; P. 7 - 43,

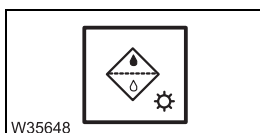

– Hydraulic oil filter; P. 7 - 101.

Blank page

7.3

Engine

- In addition, carry out further maintenance work specified in the *Engine manufacturer's documentation* supplied.

7.3.1

Check the oil level

D

Prerequisites

- The truck crane must be level.

Check the oil level

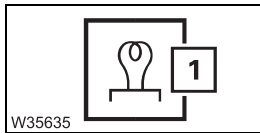

- After switching on the ignition, wait until the pre-heating lamp (1) goes out.
- Start the engine.

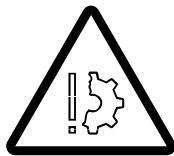

Risk of damage to the engine if the oil pressure is too low!

If the lamp (2) goes on, switch off the engine immediately.

Running the engine when the oil pressure is too low can damage it.

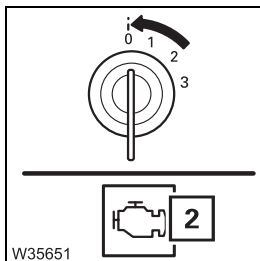

- **Switch off the engine immediately, if**
 - the lamp (2) lights up,
 - and the warning buzzer sounds.

If the lamp (2) goes on then an engine fault is present and you must have the error read. For example, the oil pressure could be too low.

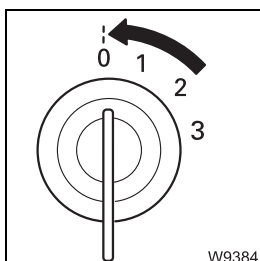

- Allow the engine to run at idling speed for 2–3 minutes.
- Switch the engine off.
- Check the oil level after a few minutes.



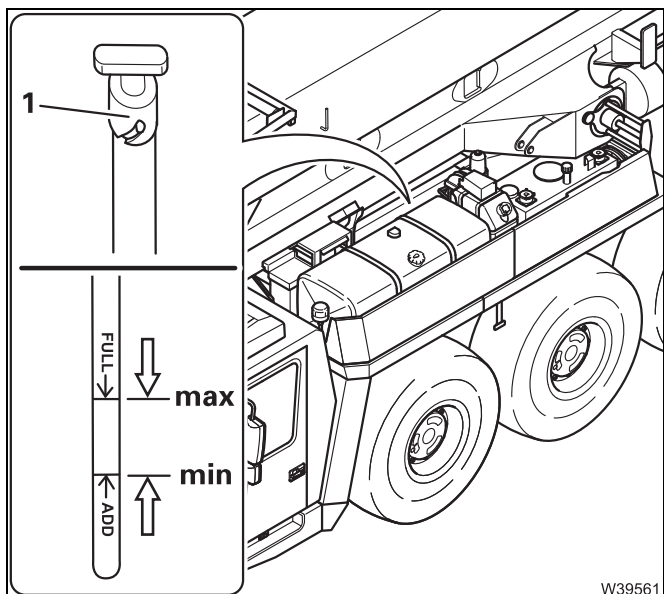

- On the dipstick (1), check that the oil level is between the **Min.** and **Max.** marks (arrow markings).
- After checking the oil level, put the dipstick back in the dipstick tube.

If the oil level is too low

- Top up with oil;  P. 7 - 13.

7.3.2

Topping up the oil

Data on the prescribed oil specifications;  *Engine manufacturer's documentation.*

Oil

Engine oil in litres (gal)	Designation to DIN 51502	Specifications Classification	GROVE part no.
53 (14.0)	HD - CD	CES 20081 Cummins	SAE 15 W-40 04162428

Prerequisites

- The truck crane must be level.
- The engine must not be running and must be secured against unauthorised use;  P. 2 - 3.

Topping up the oil



Risk of damage to the engine if the oil level is too high!

Do not overfill with oil; the oil level must not be higher than the **max.** mark (arrow marking). Drain off oil if necessary;  *Engine manufacturer's documentation.*



Risk of burns when the engine is hot!

During operation, the engine and add-on parts reach temperatures up to 400 °C (750 °F). Wear appropriate protective gloves and be careful not to touch hot parts.

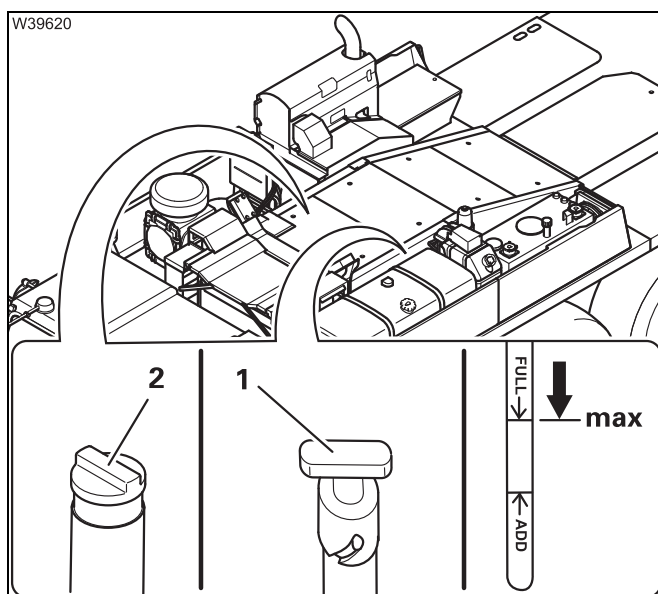

- Add oil through the filler neck (2) up to the **Max.** mark.
- Close the filler neck with the cap.
- Insert the dipstick (1) into the dipstick tube after checking the oil level.

7.3.3

Checking the air filter

D

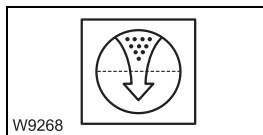

You must change the air filter if the lamp lights up.

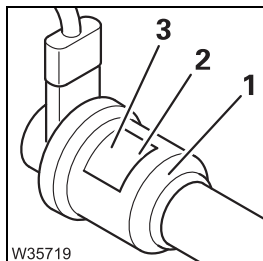

- Also check the visual pressure indicator (1) directly on the air filter. If the visual pressure indicator is in the red area (2) (CHANGE), then the air filter is clogged (100%). The green region (3) provides a prior indication of how heavily the air filter is contaminated (30%, 75%).

Spare parts and tools

Designation	Quantity	GROVE part no.
Main filter	1	90025830
Back-up filter	1	90025831

Prerequisites

- The engine must not be running and must be secured against unauthorised use; ■■■► P. 2 - 3.

Replace air filter

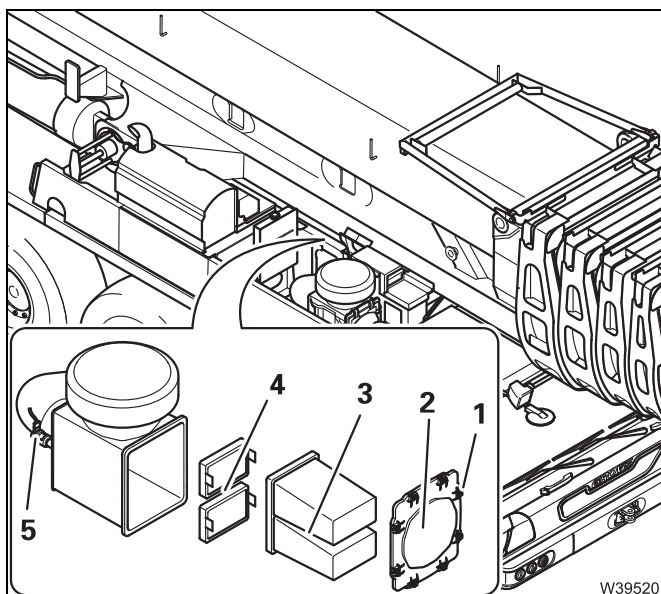

- Undo all the clamps (1) and remove the cover (2).
- Change the main filter (3) and the back-up filter (4).
- Replace the cover and secure it with all the clamps.
- Reset the visual pressure display (5).

7.3.4

Checking the coolant level

D

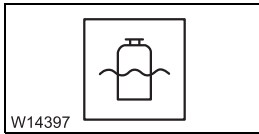

You must top up the coolant if the lamp lights up.

Topping up coolant



There is a risk of scalding when the cooling circuit is hot!

The hot cooling circuit is under pressure. When you open the expansion tank, you could be scalded by escaping vapour/coolant.

Wear suitable protective gloves and cover the cap on the expansion tank with a rag before opening it.

Turn the cap slowly to the first detent in order to allow the pressure to be released.

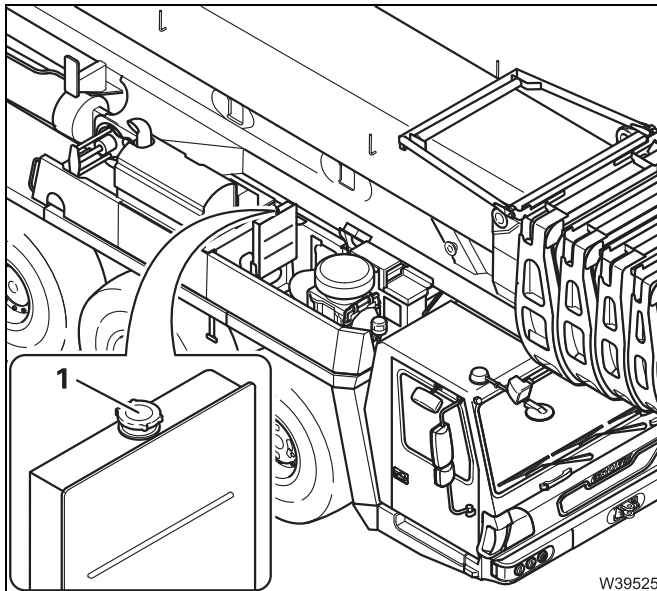

- Loosen (do not open) the cap (1) to reduce the pressure if the coolant is at operating temperature.
- Open the cap (1).
The coolant level must be at the lower marking in the filler neck.

If the coolant level is too low

- Top up the coolant.
Composition of the coolant;  *Engine manufacturer's documentation.*
- Close the cap (1).



Risk of damage to engine due to lack of coolant!

If the coolant has to be topped up frequently, the cooling system may be leaking. Have the cooling system checked by **Manitowoc Crane Care** or an authorised GROVE dealer or your repair crew.

7.3.5

General inspection

W

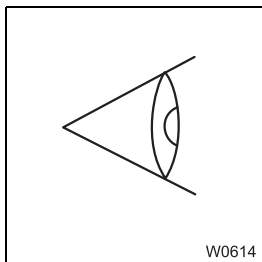

- Investigate any unusual running noises from the engine.
- Check the engine and the connections for leaks. If consumables are leaking;
 - ▶▶▶ Check the oil level, P. 7 - 11,
 - ▶▶▶ Checking the coolant level, P. 7 - 15.
- Check that pipes and hoses are tightly connected and undamaged.

If any damage is found, report it to **Manitowoc Crane Care** or an authorised GROVE dealer or an authorised specialist workshop.

7.3.6

Changing the oil and oil filter

M 6



Oil, spare parts,
tools

Engine oil in litres (gal)	Designation to DIN 51502	Specifications Classification	GROVE part no.
53 (14.0)	HD - CD	CES 20081 Cummins	SAE 15 W-40 04162428

Designation	Quantity	GROVE part no.
Oil filter	1	04241344
O ring on the drain plug	1	04241329

– Receptacle, approx. 60 l (16 gal);  P. 2 - 4.

Prerequisites

- Find out the prescribed oil specifications and about the need to shorten the maintenance interval under special operating conditions;  *Engine manufacturer's documentation.*
 - Find out about the safety instructions and the sequence of steps to change the oil and the oil filter;  *Engine manufacturer's documentation.*
- The truck crane must be level.
- The engine must not be running and must be secured against unauthorised use;  P. 2 - 3.

Changing



Risk of environmental damage due to leaking consumables!

Always let consumables drain into suitable receptacles. Wipe up any consumables that escape.

Store/dispose of consumables and any soaked equipment properly.

Ask about the applicable regulations.



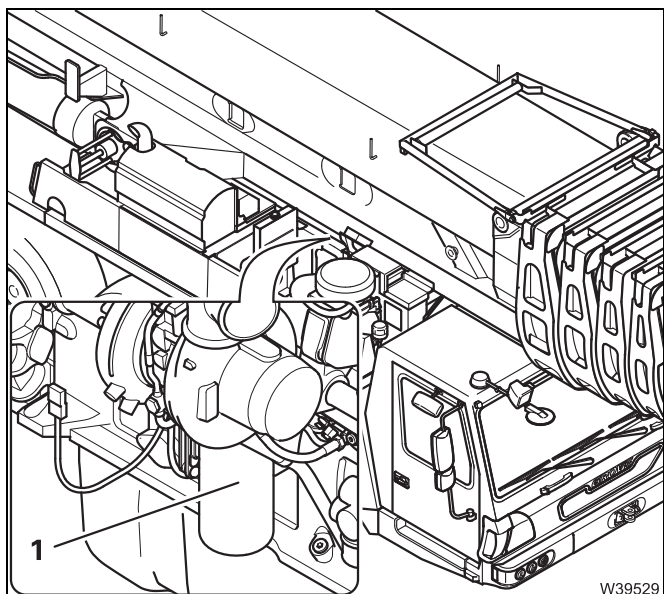

Oil filter

- Place a receptacle underneath the engine.
- Unscrew the filter (1).
- Apply a light film of oil to the seal of the new filter (1) and firmly screw it in by hand.

- Leave the receptacle in place for the oil change.

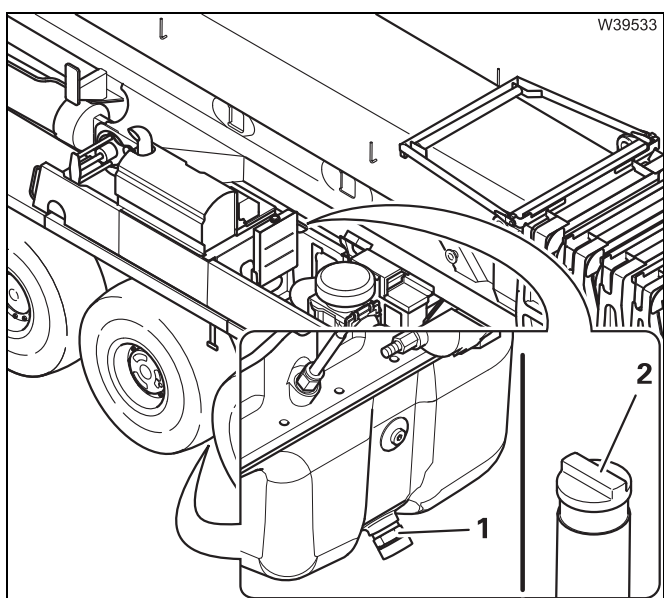

Draining oil

- Unscrew the drain plug (1) and let the oil drain off.
- Fit a new gasket and tighten the screw (1).
- Remove the receptacle.

Topping up the oil

- Top up with fresh oil through the filler neck (2);  P. 7 - 13.

7.3.7



Have the radiator checked/cleaned

M 12

Reducing the interval

- Under difficult operating conditions – at extremely sandy or dusty locations or if there is a heavy density of fallen leaves – you must have the radiator fins cleaned earlier than this.

Prerequisites

- The truck crane must be supported on outriggers and must be level;  *Operating manual*.
- The main boom must be fully retracted and raised to 75;  *Operating manual*.
- The engine must not be running and must be secured against unauthorised use;  P. 2 - 3.
- The cover above the cooler between the driver's cab and the boom rest has been removed.
- Trained repair crew and repair tools must be available.

Check the level of dirt

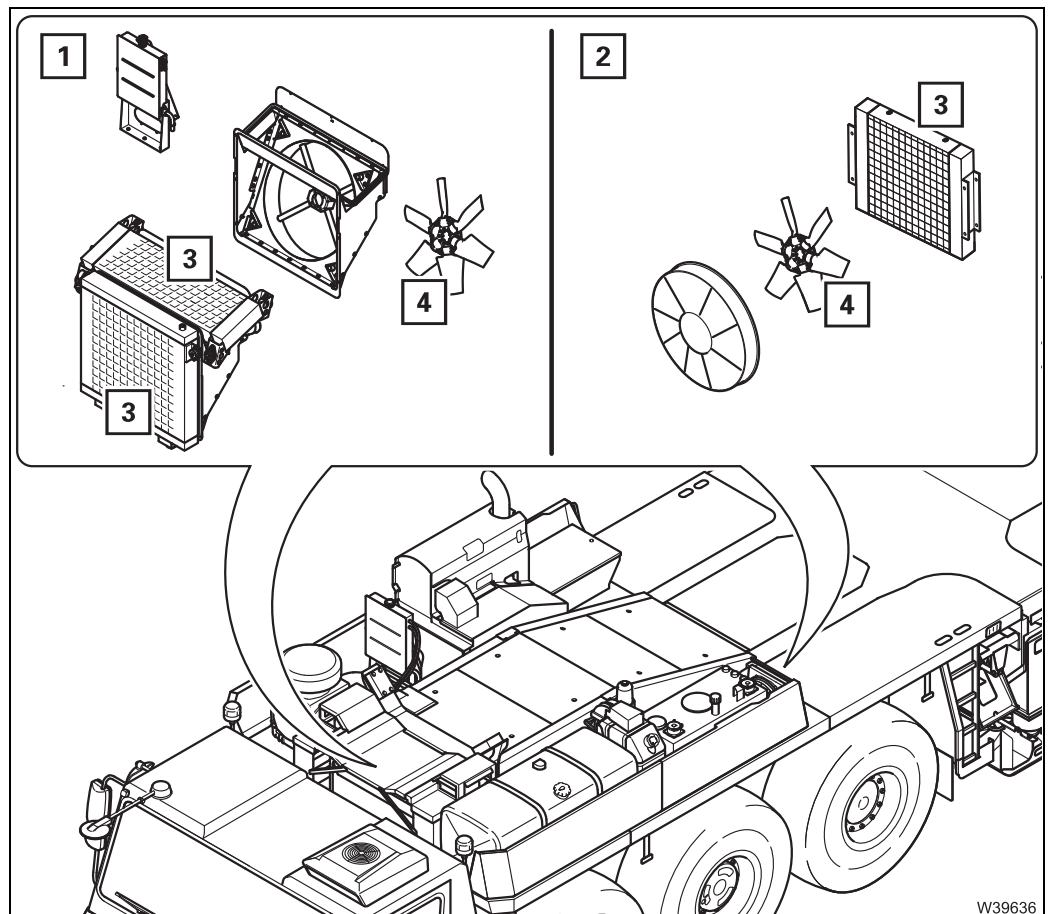

The radiator units are protected by grilles (3) and plates. The fan wheels (4) are located under the grilles. When the engine is running, the fan impellers rotate behind the grilles!



Risk of injury due to the fan impellers!

When the fan impellers are rotating they can trap the fingers of your hand and amputate them. Never reach into the fan impellers when they are rotating. Do not push any tools through the grilles to clean them.

Always stop the engine before attempting to clean the fan impellers and radiator fins.

Radiator unit 1

Radiator for the engine cooling water, radiator for the engine charge air.

Radiator unit 2

Cooler for hydraulic oil.

Checking

- If necessary remove leaves, twigs and other debris from the grilles (3).
- View the fan impellers (4) through the grilles from above to check their condition. The impeller blades must be clean and undamaged.



If the radiator fins are heavily soiled have them cleaned, since further soiling can lead to overheating;  *Have them cleaned, P. 7 - 21.*

**Have them
cleaned**



Risk of injury due to the fan impellers!

When the fan impellers are rotating they can trap the fingers of your hand and amputate them. Never reach into the fan impellers when they are rotating. Do not push any tools through the grilles to clean them.

Always stop the engine before attempting to clean the fan impellers and radiator fins.



Risk of damaging the radiator fins!

Do not use a high pressure cleaner or steam jet cleaner. The powerful jet may damage the fins.

Use only suitable cleaning agents air for cleaning.

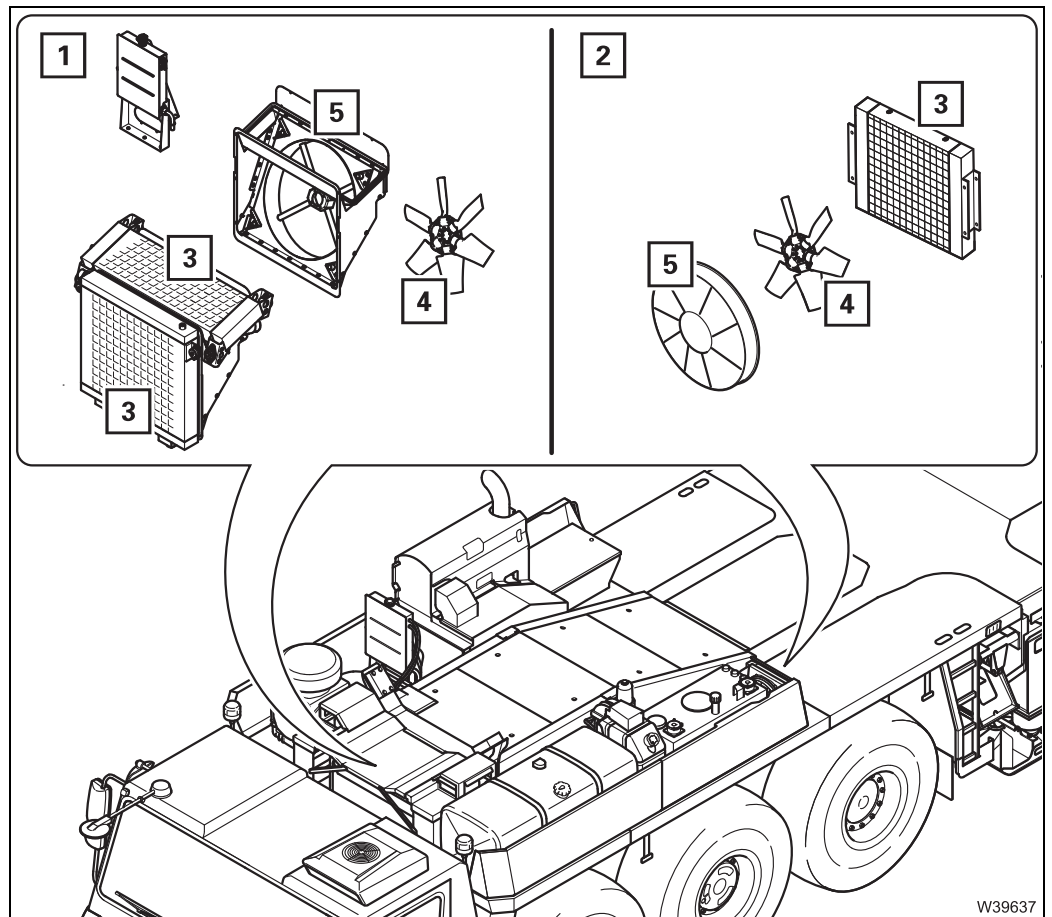

W39637



- Have the radiator units (1) and (2) opened up by the repair specialists, so that the radiator fins are accessible.
- Have the radiator fins cleaned on both sides, using suitable cleaning agents.
- Have the fan impeller (4) cleaned.
- Have the cooling air baffle (5) cleaned.
- Have the hoses and connections checked for damage and leaks.
- Have any damaged parts replaced.

**After checking/
cleaning**



- Remove all tools and cleaning equipment.
- Check that all the grilles (3) and plates (5) are securely fastened.
- Start the engine and wait until the fan impellers are rotating.
- Check that the fan impellers are running freely.
- Check the respective temperature displays in the driver's cab;
 ▣▣▣▣► *Operating manual*.
- Switch the engine off.
- Check the radiator and connections for leaks.

7.3.8



Changing the coolant

M 12

Tools

- Receptacle, approx. 50 l (13.5 gal);  P. 2 - 4.
- Antifreeze 50 l (13.5 gal);  *Engine manufacturer's documentation.*

Prerequisites

- Information on the coolant and admixture ratio has been obtained;  *Engine manufacturer's documentation.*
- The truck crane must be level.
- The engine must not be running and must be secured against unauthorised use;  P. 2 - 3.
- The engine has cooled down.



Risk of environmental damage due to leaking consumables!

Always let consumables drain into suitable receptacles. Wipe up any consumables that escape.

Store/dispose of consumables and any soaked equipment properly. Ask about the applicable regulations.



There is a risk of scalding when the cooling circuit is hot!

The hot cooling circuit is under pressure. When you open the expansion tank, you could be scalded by escaping vapour/coolant.

Wear suitable protective gloves and cover the cap on the expansion tank with a rag before opening it.

Turn the cap slowly to the first detent in order to allow the pressure to be released.

Changing

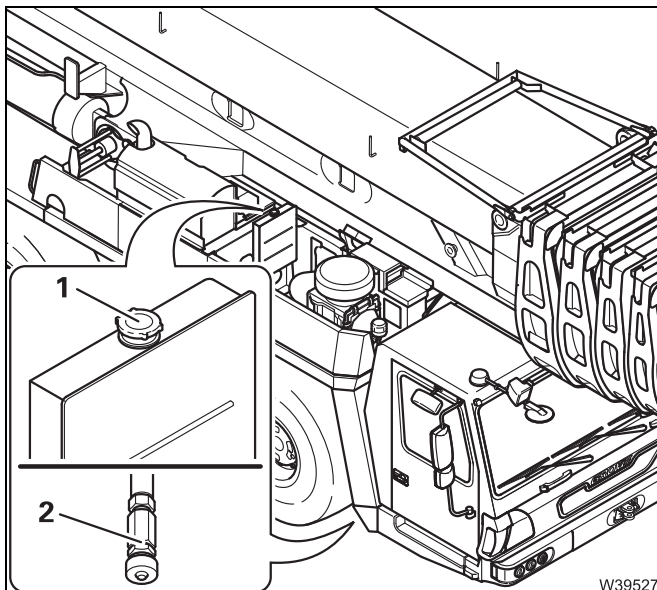

Draining when the engine is cold

- Open the cap (1) on the expansion tank.
- Place a receptacle under the valve (2) under the cab.
- Open the valve (2) and allow the oil to drain.
- Close the valve (2).
- Remove the receptacle.



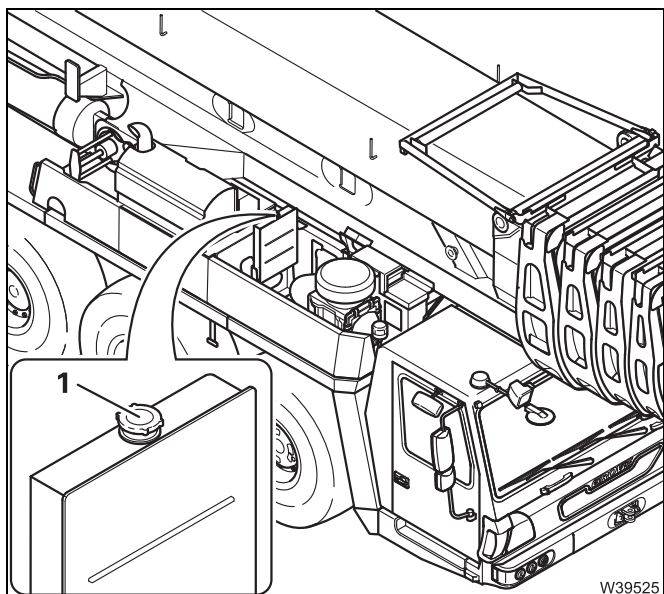

Topping up when the engine is cold

- Slowly top up the expansion tank (1) with coolant until it is filled up to the lower edge in the filler neck.
- Wait about 1 minute. Add more coolant if necessary.
- Close the cap (1).

Check it when the engine is warm

- Start the engine.
- Let the engine run at idling speed for approx. 5 minutes.
- Switch the engine off.
- Check the coolant level when the engine is warm;  *Checking the coolant level, P. 7 - 15.*

7.3.9

Changing the coolant cartridge

M 12

Spare parts and tools

Designation	Quantity	GROVE part no.
Coolant cartridge	1	04241506

Prerequisites

- The truck crane must be level.
- The engine must not be running and must be secured against unauthorised use; ■■■► P. 2 - 3.
- The engine has cooled down.

Changing the cartridge

The cartridge contains a anticorrosive (additive), which is continuously added to the coolant.

- Change the cartridge
 - after 12 months,
 - after 4,000 operating hours,
 - after 240,000 km (15 000 mi) or
 - if necessary, when changing the coolant; ■■■► P. 7 - 23.
- Inform yourself about changing the cartridge in the documentation supplied; ■■■► *Engine manufacturer's documentation*.

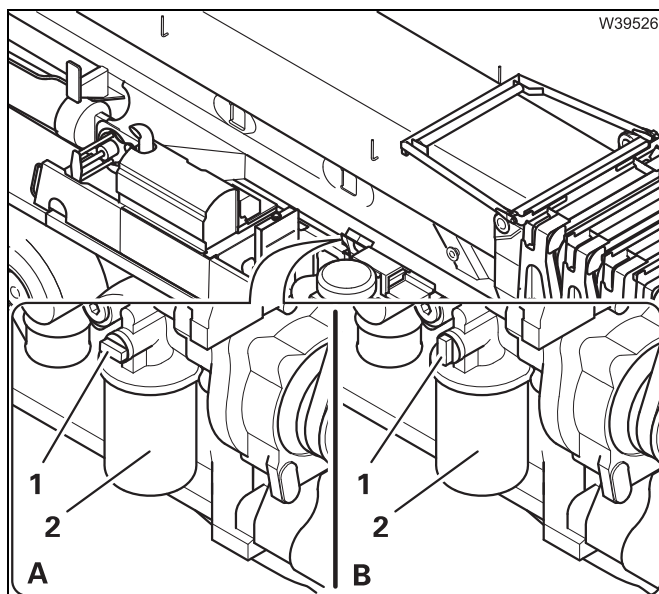

- Close the valve (1) – at right angles to the line.
- Place a receptacle under the cartridge (2).
- (A) – Remove the cartridge.
- (B) – Screw on a new cartridge (lubricate gasket lightly).
- Open the valve – parallel to the line.
- Remove the receptacle.

- Check the coolant level; ■■■► P. 7 - 15.

Blank page

7.4

Fuel system

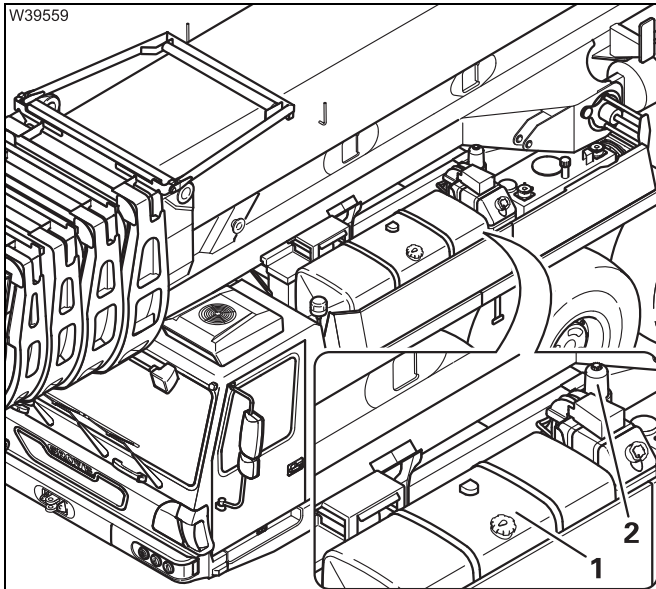

The following elements are installed in the carrier fuel system:

- 1 Fuel tank
- 2 Fuel filter 1

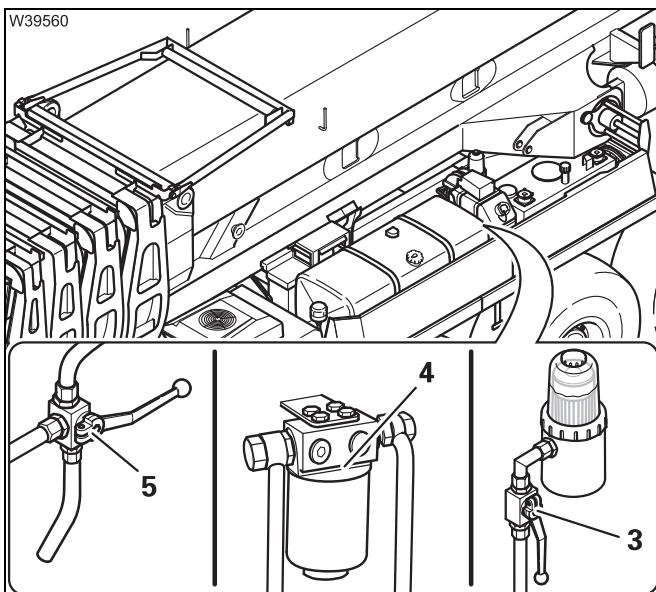



- 3 Valve in the supply line; for shutting off the supply
- 4 Fuel filter 2
- 5 3-way valve in the return line; for draining the fuel

7.4.1

Checking fuel filter 1

D

Prerequisites

- The truck crane must be level;  *Operating manual*.
- The engine must not be running and must be secured against unauthorised use;  P. 2 - 3.

Checking

You can visually check the degree of contamination (6) of the internal filters (5) through the transparent cover (1).

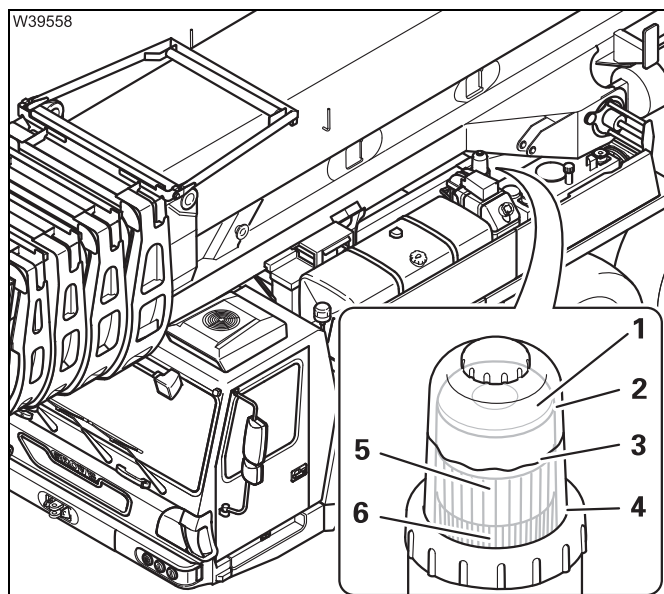

Visual inspection

- Clean the cap (1) with a cloth if necessary.
- Check that the fuel level (3) lies between the lower ring (4) and the upper ring (2).

The fuel level (3) must always be higher than the dark discoloration (6) of the filter (5) due to the contamination.

This ensures that the fuel always flows through the upper, clean region of the filter.

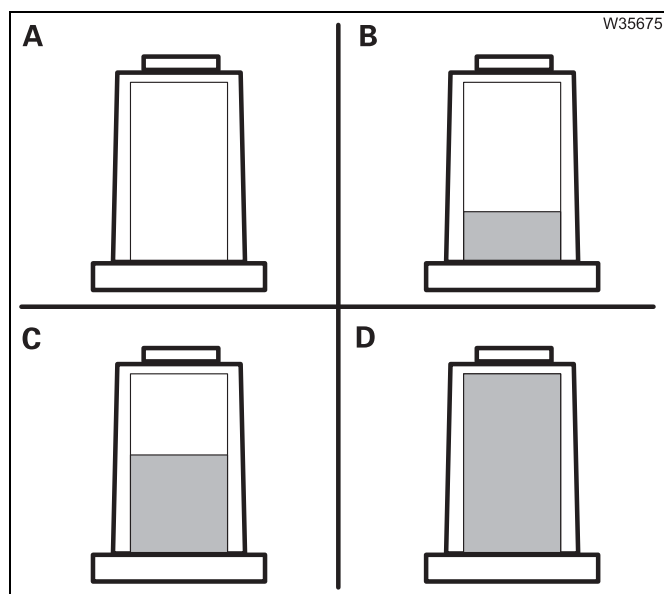

Degree of soiling

- A** 0% soiling:
Filter is new:
- B** 25% soiling.
- C** 50% soiling.
- D** 100% soiling:
Filter is full; replace.

- Check the degree of soiling.
- Change the filter at the very latest when soiling degree (D) is reached.

7.4.2



Draining off water from fuel filter 1

D

Spare parts and tools

- Receptacle, approx. 5 l (1.5 gal);  P. 2 - 4.

Prerequisites

- The truck crane must be level;  *Operating manual*.
- The engine must not be running and must be secured against unauthorised use;  P. 2 - 3.

WIF sensor

Fuel filter 1 is equipped with a chamber in the lower region that collects the separated water.

The sensor emits a signal when the chamber is full (WIF = Water in Fuel).

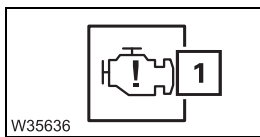

If the engine malfunction lamp (1) on the instrument panel lights up (have the error code read) then you must drain the water from fuel filter 1.

- Where possible, drain the water regularly before the sensor is triggered.
- Note that the quality of the fuel, and thus the water content, can vary greatly with the application location.
- **Daily** water draining may be necessary in the case of very low quality fuel.

Draining off water



Risk of environmental damage due to leaking consumables!

Always let consumables drain into suitable receptacles. Wipe up any consumables that escape.

Store/dispose of consumables and any soaked equipment properly.

Ask about the applicable regulations.

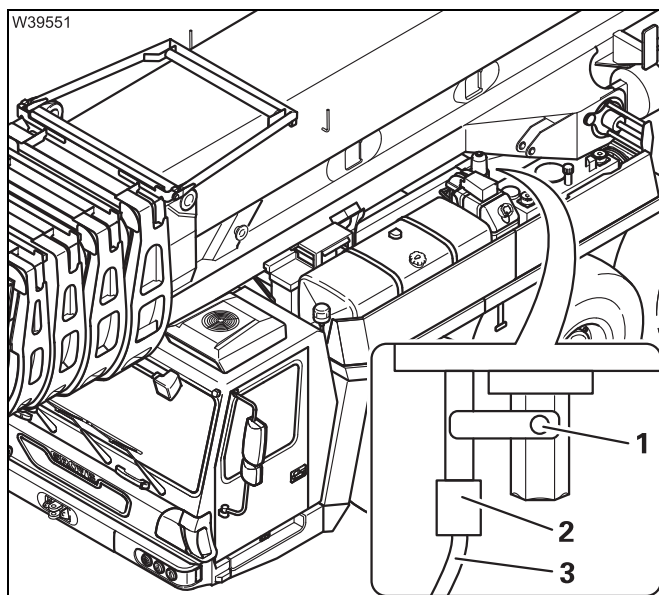

- Place a receptacle underneath the filter.
- Open the valve – lever (1) parallel to the line.
- When clean fuel escapes, close the valve – lever (1) at right angles to the line.
- Remove the receptacle and properly dispose of the drained consumable.
- Check the fastening of the electrical connecting cable (3) to the water sensor (WIF = Water in Fuel) (2).

7.4.3

Replacing fuel filter 1

M 6

Interval

The engine manufacturer specifies a interval of 500 oper. hrs. (M 6) for changing the fuel filter; *Engine manufacturer's documentation.*

- Change the filter at the very latest when soiling degree (D) is reached; P. 7 - 28.

Spare parts and tools

Designation	Quantity	GROVE part no.
Filter	1	04256757

- Receptacle, approx. 5 l (1.5 gal); P. 2 - 4.
- Special wrench for the ring on the cover (GROVE part no. 04256759).

Prerequisites

- The truck crane must be level and on outriggers; *Operating manual.*
- The engine must not be running and must be secured against unauthorised use; P. 2 - 3.

Changing



Risk of environmental damage due to leaking consumables!

Always let consumables drain into suitable receptacles. Wipe up any consumables that escape.

Store/dispose of consumables and any soaked equipment properly.

Ask about the applicable regulations.

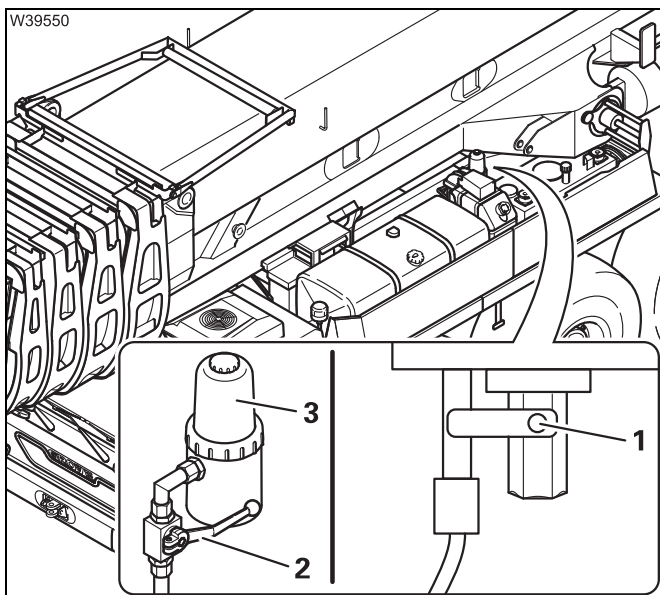

- Place a receptacle underneath the filter.
- Close the valve – lever (2) at right angles to the line.
- Open the valve – lever (1) parallel to the pipe, and allow the consumable to drain fully out of the transparent cover (3).
- Close the valve – lever (1) at right angles to the line.

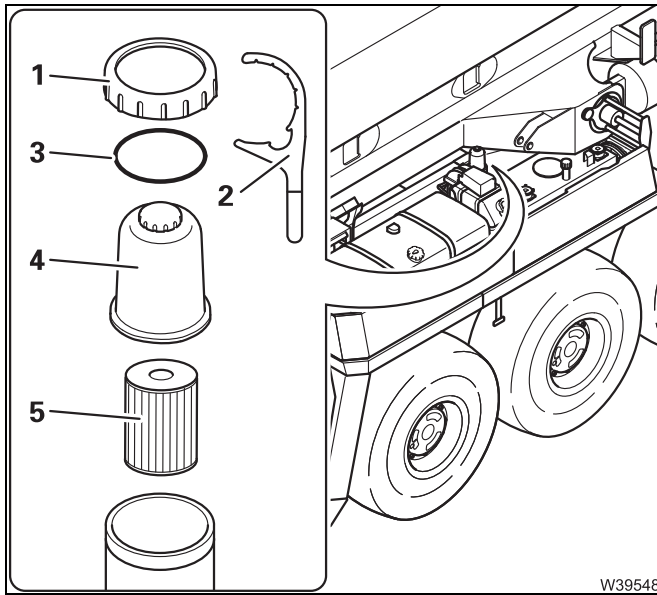

- Release the pin (1) using the special wrench (2).
- Remove the ring (1) upwards and off.
- Remove the cap (4).
- Remove the old filter (5) and place it in the receptacle.
- Insert a new filter (5).
- Replace the seal (3) in the ring (1).
- Fit the cover (4).
- Slide the ring (1) over the cover (4) and fasten the ring (1) using the special wrench (2).
- Remove the receptacle.

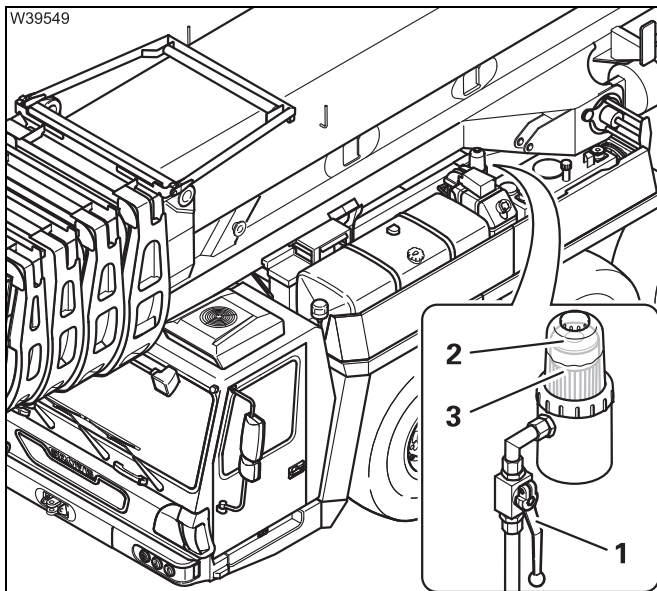

- Open the valve (1) – lever parallel to the line.
- Observe the increasing fuel level through the transparent cover (2). After the increase, the fuel level must be above the ring (3). This corresponds to degree (A) with a new filter; ■■■► P. 7 - 28.

- If necessary, also replace fuel filter 2 before starting the engine; ■■■► Replacing fuel filter 2, P. 7 - 32.
- Start the engine and check for leaks.

7.4.4

Replacing fuel filter 2

M 6

Spare parts and tools

Designation	Quantity	GROVE part no.
Filter	1	04241343

- Receptacle, approx. 5 l (1.5 gal); ▮▮▮▮ P. 2 - 4.
- Strap wrench.

Prerequisites

- The truck crane must be level and on outriggers; ▮▮▮▮ *Operating manual*.
- The main boom must be fully raised; ▮▮▮▮ *Operating manual*.
- The engine must not be running and must be secured against unauthorised use; ▮▮▮▮ P. 2 - 3.
- If the fuel is dirty: Reduce the maintenance interval.

Changing



Risk of environmental damage due to leaking consumables!

Always let consumables drain into suitable receptacles. Wipe up any consumables that escape.

Store/dispose of consumables and any soaked equipment properly. Ask about the applicable regulations.

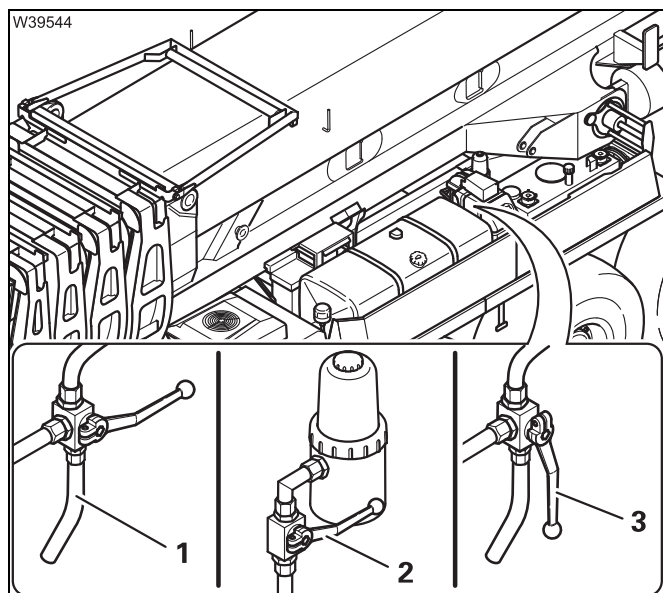

Emptying the line

- Place a receptacle under the line (1).
- Close the valve – lever (2) at right angles to the line.
- Open the valve – lever (3) parallel to the line.
- Let the consumable drain.

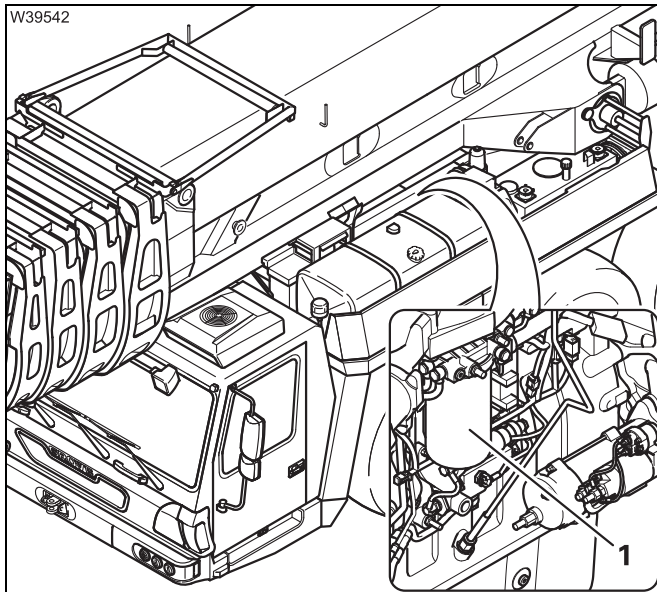

Changing the filter

- Place a receptacle under the filter (1).
- Remove the filter (1).
- Fill a new filter (1) with clean consumable and screw it up (lightly grease the gasket).
- Remove the receptacle.

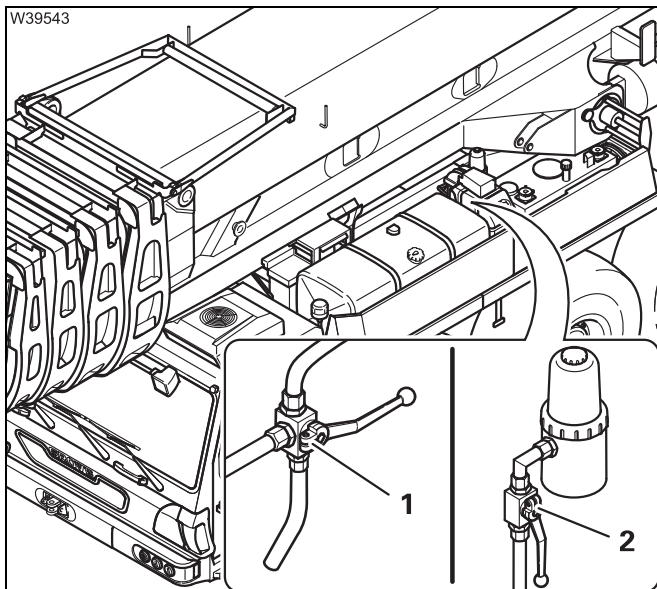

Establishing an operational status

- Open the valve (2) – lever parallel to the line.
- Close the valve – lever (1) at right angles to the line.
- Remove the receptacle.



If you have used a clean receptacle, you can refill the fuel tank with the consumable using a filter.
Otherwise dispose of the consumable properly.



It is not necessary to bleed air from the fuel line when starting this engine.

- Start the engine and check for leaks.

Blank page



7.5

Exhaust system with exhaust emission control

Overview

In order to adhere to the exhaust emission regulations, you are only permitted to drive the crane with the **multi-stage exhaust system** consisting of **DOC catalytic converter, DPF particle filter, SCR catalytic converter** (**DOC = Diesel Oxidation Catalyst, DPF = Diesel Particulate Filter, SCR = Selective Catalytic Reduction**).

The exhaust gas is cleaned with an **AdBlue system (DEF)**. **AdBlue (DEF) (Diesel Exhaust Fluid)** from the DEF tank is injected into the mixing tube in the exhaust system for this.

The motor output is automatically sharply reduced when there is not enough AdBlue solution available. Driving with an empty AdBlue tank will invalidate the truck crane's licence for use on public roads;  *Operating manual*,  *Engine manufacturer's documentation*.

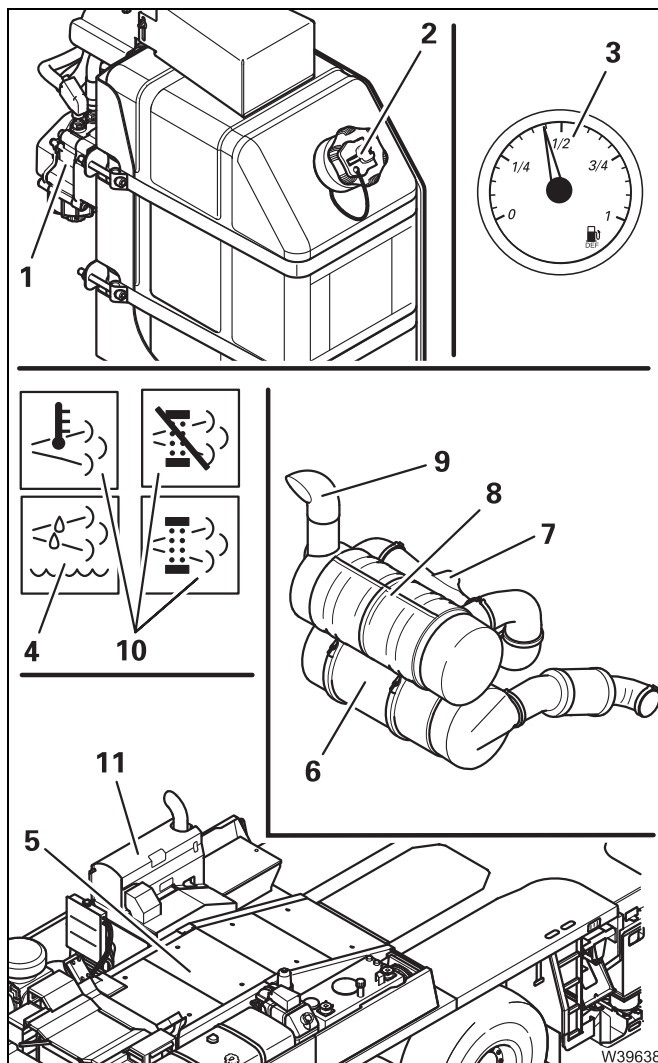

AdBlue system

- 1 Pump unit for pumping AdBlue to the dosing unit on the diesel engine and for pumping engine coolant for preheating the AdBlue tank.
- 2 AdBlue tank.
- 3 Tank gauge, AdBlue tank
- 4 Warning lamps: AdBlue system fault.
- 5 Diesel engine with dosing unit for AdBlue (compressed air supply) and a solenoid valve for preheating the AdBlue tank using engine coolant.
- 6 Exhaust pipe: DOC catalytic converter and DPF particle filter.
- 7 AdBlue mixing tube with injection nozzle for injecting the AdBlue/compressed air mixture.
- 8 Exhaust pipe: SCR catalytic converter.
- 9 Exhaust end pipe.
- 10 3 warning lamps: Exhaust gas temperature, active/passive regeneration of the exhaust gas filter.
- 11 Heat shield.

7.5.1

Checking the AdBlue tank level

D

Checking

The warning lamp for checking the DEF system and a gauge for checking the tank DEF level are located on the instrument panel in the driver's cab.



The tank has a maximum filling volume of approx. 56.8 l (15 gal). Depending on where the truck crane is used, it may be sensible to carry additional canisters of AdBlue.

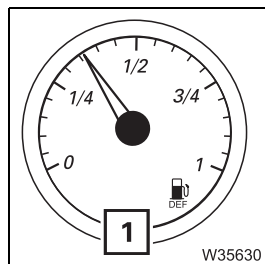

- Start the engine.
- Check the AdBlue level in the tank via the display (1) in the driver's cab; *Operating manual*.
- Refill the tank when the AdBlue level falls below one quarter (1/4) at the very latest.

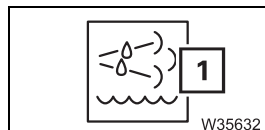

- Check the warning lamp (1). The lamp lights up when the AdBlue tank is empty or when a fault occurs in the AdBlue system.

7.5.2

Filling up with AdBlue

Consumable and tools

AdBlue in litres (gal)	Specifications Classification	GROVE part no.
56.8 (15)	DEF (Diesel Exhaust Fluid) e.g. <i>AdBlue</i> .	03140555

- As required: 2 canisters of about 20 l each (5 gal); P. 2 - 4.

Prerequisites

- A service station with a filling pump for AdBlue can be used, or AdBlue can be filled manually from canisters.
- The engine must not be running and must be secured against unauthorised use; P. 2 - 3.

Refuelling

- Find out about filling up in the operating manual and note the warnings;
 ▣▣▣▣► *Operating manual.*



Danger of scalding due to ammonia vapours!

Ammonia vapour can escape if the AdBlue tank is opened when the outside temperature is high. Ammonia vapours can irritate mucous membranes, skin and eyes.

Ensure that there is adequate fresh air supply and do not breathe in the escaping ammonia vapours.

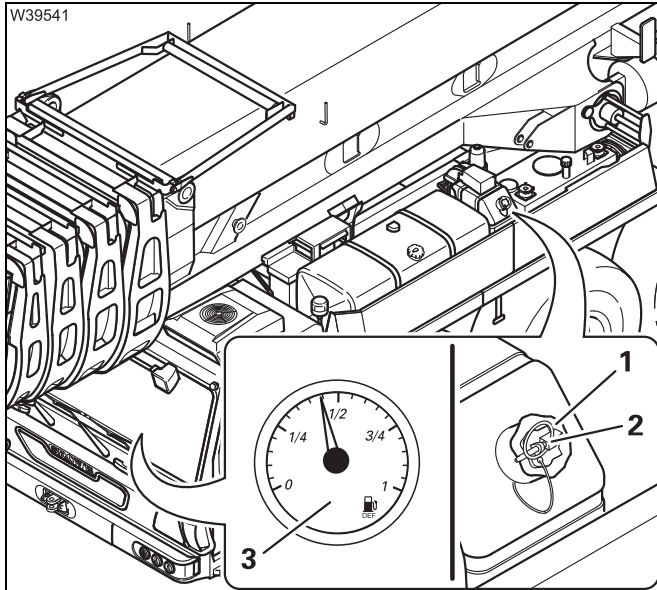

- Fill the AdBlue tank via the filler neck (1) and close it using the cap.
- Secure the cap with the securing plug (2).
- Check the level on the display (3) in the driver's cab; ▣▣▣▣► P. 7 - 36.

7.5.3

Check the exhaust system for external damage

M 1

Spare parts and tools

Designation	Quantity	GROVE part no.
Entire exhaust system	1	04168557
– DOC catalytic converter + DPF particle filter	1	04175209
– AdBlue mixing tube	1	04175194
– SCR catalytic converter	1	04175193

Prerequisites

- The engine must not be running and must be secured against unauthorised use; ▣▣▣▣► P. 2 - 3.
- The engine and the exhaust system must be cool.



Checking



Risk of burns if the exhaust system is hot!

The exhaust system becomes extremely hot during operation.

Especially during the *regeneration phases*, the exhaust gas temperature can reach 600 °C (1100 °F).

Wear suitable gloves and wait until the exhaust system has cooled down.

Make sure not to touch any hot parts.

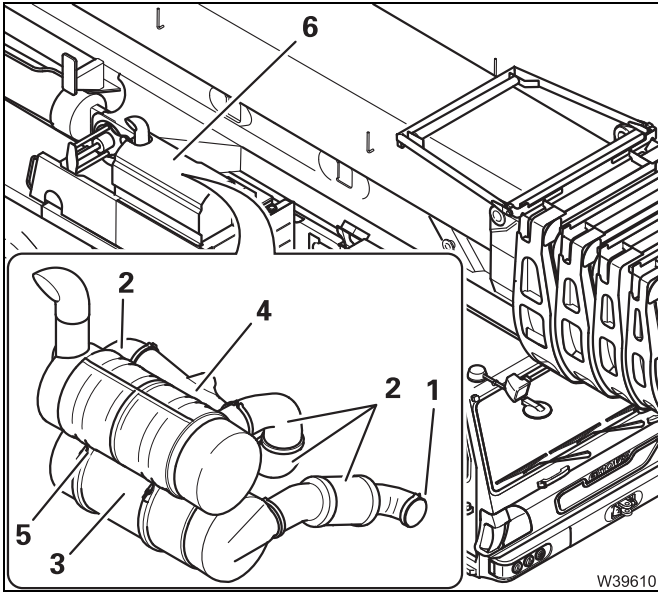

- Remove the heat shield (6).
- Check the exhaust pipes (2) for damage, from the engine (1) to the DOC catalytic converter with DPF particle filter (3), the AdBlue mixing pipe (4), the SCR catalytic converter (5) and up to the end pipe. The exhaust pipes (2) may not have any loose clamps, holes or cracks.
- Check that the area around the exhaust pipes is free of loose components which could burn by coming into contact with the hot exhaust system.
- Check the filler neck (4) for injecting AdBlue for external damage.

After checking

- Start the engine.
- Check the lamp for the AdBlue system and the lamps for the exhaust system on the instrument panel; P. 7 - 36; P. 7 - 40.
- Check whether exhaust gases are leaking from any damaged places in the exhaust system.
- Switch the engine off and allow it to cool down.
- Attach the heat shield (6).

If you discover any damage

Have any damaged parts of the exhaust system replaced immediately by **Manitowoc Crane Care** or an authorised GROVE dealer.

7.5.4

Having the AdBlue system checked

M 12

This inspection may only be performed by **Manitowoc Crane Care** or an authorised GROVE dealer or an authorised specialist workshop!

- Have the entire AdBlue system checked for leaks and correct operation; *Overview, p. 7 - 35.*
- Also observe the information on the components mounted on the engine;
 ▣▣▣▣ *Engine manufacturer's documentation:*
 - AdBlue dosing unit,
 - Solenoid valve for engine coolant for preheating the AdBlue tank.

Maintenance interval for the pump unit

The engine manufacturer specifies additional maintenance intervals for the pump unit (1); ▣▣▣▣ *Engine manufacturer's documentation.*

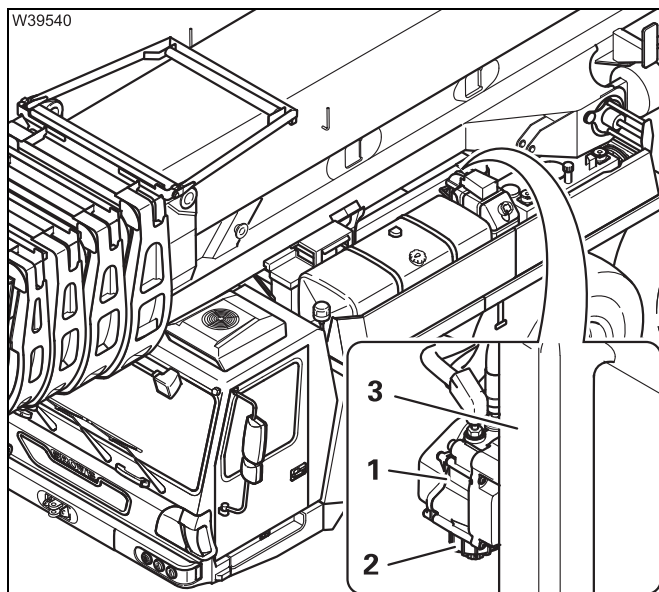

AdBlue filter

A diagnostic unit and special tools are required for this work.

The operating pressure must be discharged before replacing the filters.

- Have the AdBlue filter (2) in the pump unit (1) changed.

Grove part no. 04241341.

The operating pressure must be adjusted anew after replacing the filters!

- Have the electrically heated AdBlue cables at the pump unit (1) checked for correct operation.

The AdBlue tank (3) can be fitted with an insulation hood as extra equipment.

- Have the insulation hood checked for damage and for tight fitting on the AdBlue tank. The insulation hood prevents the AdBlue tank freezing up.





Risk of damage to the pump unit!

Oil from the compressed air system can damage the pump unit. Therefore, a filter cartridge must be installed in the compressed air drier that removes both water and oil. **Manitowoc Crane Care** recommends the suitable filter cartridge with the GROVE part number 04156032.

- Use only the suitable filter cartridge; *Replacing the filter cartridge of the compressed air drier, P. 7 - 85.*

7.5.5

Having the soot particle filter system checked

M 12

Checking daily

The exhaust system contains a soot particle filter (DPF particle filter).

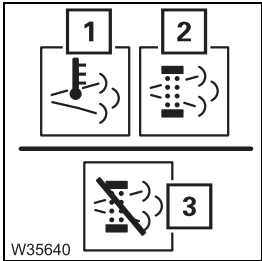

- Check the operating status of the exhaust system on a **daily** basis by checking the lamps (1) to (3) on the instrument panel in the driver's cab; *Operating manual.*
 - High exhaust gas temperature warning lamp (1),
 - passive regeneration (2),
 - active regeneration (3),



Under high loads (intensive crane operation for longer periods of time), the **passive** regeneration system ensures permanent conversion of the soot particles into gases that are then expelled. Under long periods of operation at low loads (city traffic) the warning lights indicate that the system has switched over to **active** regeneration.

Active regeneration switches on automatically when the soot particle filter is in danger of clogging. When this occurs, more diesel is injected into the engine, which significantly increases the exhaust gas temperature and burns the soot filter free of soot.

Active regeneration can be manually suppressed (3), and specific soot-burning cycles are available; *Operating manual*; *Engine manufacturer's documentation.*

The soot particles are not completely burned away without residue, so that the ash must be removed after a long period of operation; P. 7 - 41.

Have the ash removed

The maintenance periods can fluctuate greatly depending on the truck crane operating conditions, fuel quality and engine oil quality. Under good operating conditions the ash must be removed after five years (Y 5), 100,000 km (62,000 mi), or 5,000 operating hours (5,000 oper. hrs.).

Service partner

- Have the particulate filter cleaned by service partners. Information can be obtained from **Manitowoc Crane Care**.

Prerequisites

- The engine must not be running and must be secured against unauthorised use;  P. 2 - 3.
- The exhaust system has cooled down.



Risk of burns if the exhaust system is hot!

During operation, the exhaust system can heat up to 600 °C (1100 °F). Wear suitable gloves and/or wait until the exhaust system has cooled down. Make sure not to touch any hot parts.



Soot particles can be a health hazard.

Soot particles are suspected of being hazardous to health. Wear appropriate dust respirator masks and be careful not to breathe in or ingest soot particles.



Risk of polluting the environment

Collect the combustion residues from the particulate filter in a suitable receptacle and dispose of them according to the relevant regulations.

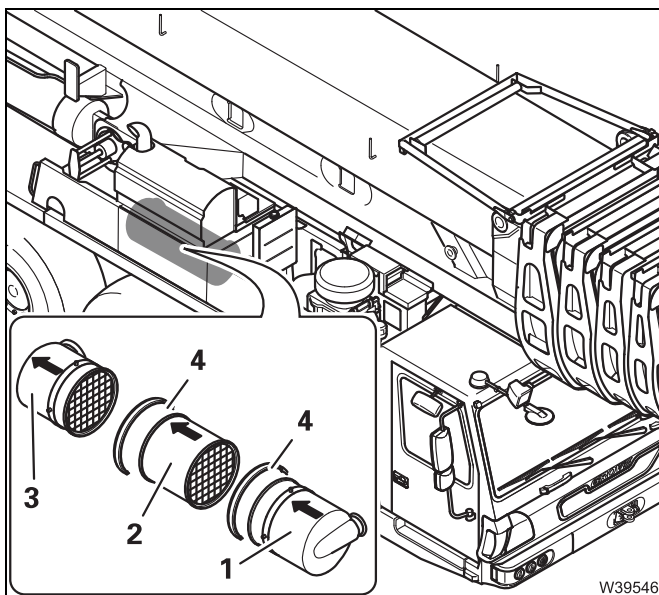

Have them removed

- Mark the exhaust flow direction on the parts.
- Release the tensioning straps (4) and remove the subsections one after another:
 - Inlet piece (1),
 - DPF particle filter (2),
 - Outlet piece (3).



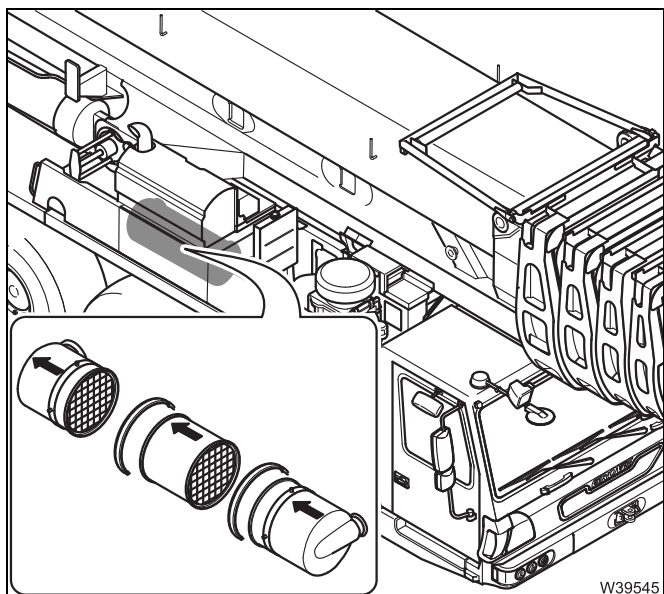

Have them cleaned

- Only clean the filter in a system approved by the filter manufacturer.
- Replacement filters are available from the filter manufacturer's service partner if you do not have a cleaning system available.
- If necessary, replace damaged filters and tensioning straps with defective seals.

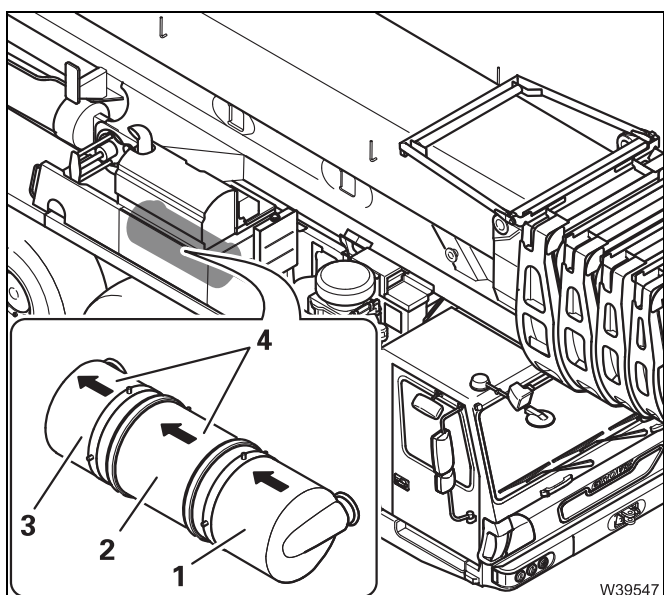

Have them installed

- Observe the exhaust flow direction markings on the parts.
- Assemble the subsections (1) to (3).
- Tighten the tensioning straps (4) to the specified torque.
- Ensure that the subsections are properly sealed to each other with the tensioning straps.
- Completely install the exhaust system.

- Have a back pressure test performed to check if the exhaust system is gas-tight.

If you discover any damage

Have any damaged parts of the exhaust system replaced immediately by **Manitowoc Crane Care** or an authorised GROVE dealer.

7.6

Transmission

7.6.1

Check the oil level

D

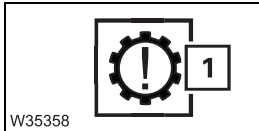

- Check the warning lamp (1) on the instrument panel in the driver's cab on a daily basis.
- Switch on the ignition.
 - The warning lamp (1) lights up briefly and then goes out.
 - There is no transmission malfunction – the engine can be started.

If the lamp (1) is lit

- There is a transmission malfunction – the engine may not be started.
- Have the transmission malfunction corrected immediately.



Risk of damage to the transmission!



If the oil level is too low or too high, this can lead to malfunctions and damage to the transmission.

Carry out the oil level checks in the sequence specified.

Prerequisites

- The truck crane must be level.
- The parking brake must be applied.
- The transmission must be in neutral position **N**.

Sequence of checks

- Check the oil level in the transmission daily in this sequence:
 - prior to starting the engine;  P. 7 - 44.
 - when the gear oil is cold;  P. 7 - 44.
 - when the gear oil is warm;  P. 7 - 45.



To prevent damage to the transmission, the oil level check is always most accurate when the gear oil is warm.



When the engine is running, the gear oil level will continue to be monitored by the oil level sensor;  *Operating manual*.



Prior to starting the engine

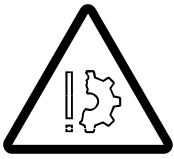

Risk of damage to the transmission!

The engine must not be started without the gear oil level having been checked beforehand. This prevents damage to the transmission being caused by undetected loss of oil.

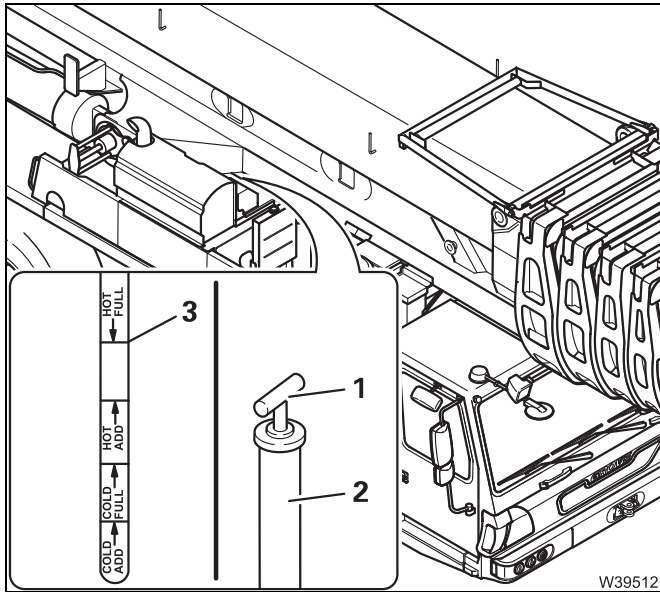

- On the dipstick (1), check whether the oil level is roughly at the mark (3).

If the oil level is too low

- Top up the oil via the dipstick tube (2).
- Insert the dipstick into the dipstick tube.
- Now check the oil level when the gear oil is cold; P. 7 - 44.

When the gear oil is cold

- If necessary, heat up the gear oil to a temperature range between 15 and 50 °C (60 to 120 °F); *Warming up the gear oil*, P. 7 - 45.

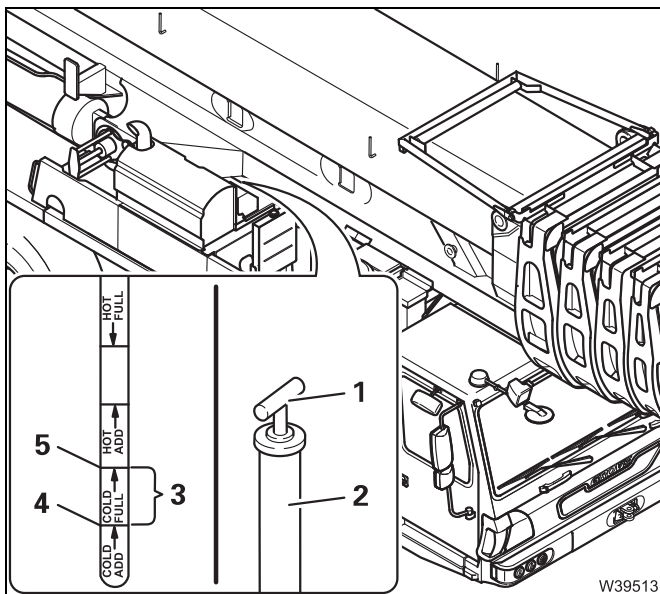

- On the dipstick (1), check whether the oil level lies in region (3).

If the oil level is too high

- Drain off oil until it is below the mark (5); P. 7 - 48.

If the oil level is too low

- Top up the oil via the dipstick tube (2) until the mark (4) is exceeded.
- Insert the dipstick into the dipstick tube.
- Now check the oil level when the gear oil is warm; P. 7 - 45.

When the gear oil is warm

- Heat up the gear oil to a temperature range between 75 and 95 °C (160 to 200 °F); **▶▶▶▶** *Warming up the gear oil*, P. 7 - 45.

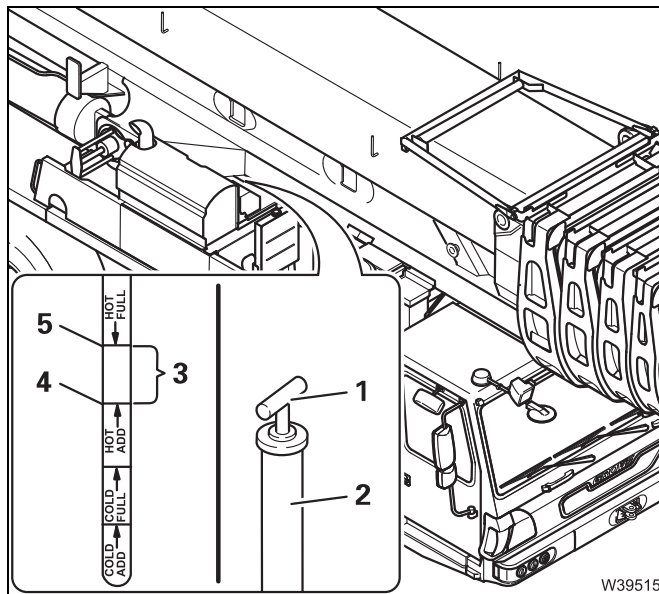

- On the dipstick (1), check whether the oil level lies in region (3).

If the oil level is too high

- Drain off oil until it is below the mark (5); **▶▶▶▶** P. 7 - 48.

If the oil level is too low

- Top up the oil via the dipstick tube (2) until the mark (4) is exceeded.
- Insert the dipstick into the dipstick tube.

Warming up the gear oil

You warm up the gear oil by

- allowing the truck crane to warm up while the vehicle is stationary or
- by accelerating the truck crane to warm it up while the vehicle is stationary or
- driving the truck crane.

Warming it up when stationary

- Allow the engine to run at idling speed in neutral position **N**.
- Check the gear oil temperature.
- Wait until the prescribed temperature range is reached.
- Switch the engine off and check the gear oil level; **▶▶▶▶** *When the gear oil is cold*, P. 7 - 44; **▶▶▶▶** *When the gear oil is warm*, P. 7 - 45.

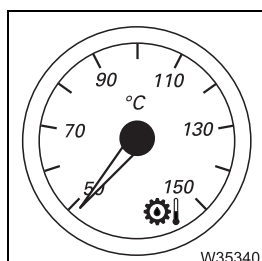

Speeding up the warming up procedure

- Allow the engine to run at idling speed in neutral position **N**.
- Fully press the service brake pedal, even if the parking brake is applied.

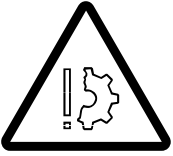



Risk of damage to the transmission when speeding up the warming up procedure!

When the wheels are locked, the full engine output may only be applied in transmission mode **D** or **R** for a maximum of 30 seconds. If this duration is exceeded, the transmission could become overheated and be damaged.





Risk of scalding from escaping coolant

During accelerated warming up, coolant may escape from the expansion tank, before the display shows a coolant temperature of 70 °C (160 °F). The coolant then leaks from the expansion tank.

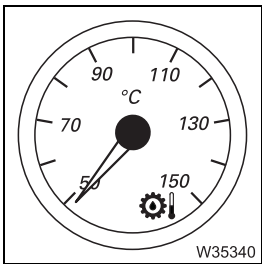
- Shift first to transmission mode **D** and then to **R** and allow the engine to run briefly at approx. 1,200 - 1,500 rpm in each transmission mode for a maximum of 30 seconds.
- Shift into neutral position **N** and let the engine run at idling speed.
- Check the gear oil temperature.
- Wait until the prescribed temperature range is reached.
- Switch the engine off and check the gear oil level;  *When the gear oil is cold, P. 7 - 44;*  *When the gear oil is warm, P. 7 - 45.*



Driving the truck crane

- Check the gear oil temperature.
- Wait until the required gear oil temperature is reached.
- Stop and apply the parking brake.
- Align the truck crane horizontally.
- Shift into the neutral position **N**.
- Switch the engine off and check the gear oil level;  *When the gear oil is cold, P. 7 - 44;*  *When the gear oil is warm, P. 7 - 45.*

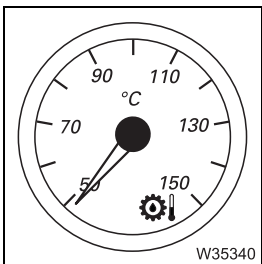

7.6.2

General inspection

W

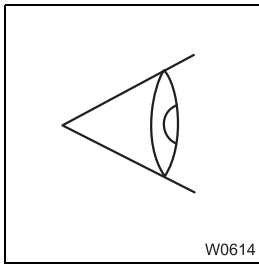

- Pay attention to any unusual running noises from the transmission.
- Check the transmission, power take-off (PTO), oil cooler, retarder and the connections for leaks. If consumables are leaking; Check the oil level, P. 7 - 43.
- Check that pipes and hoses are tightly connected and undamaged.

If any damage is found, report it to **Manitowoc Crane Care** or an authorised GROVE dealer or an authorised specialist workshop.

7.6.3

Changing the oil and oil filter

Y 2

Oil, spare parts and tools

Gear oil in litres (gal)	Specifications Classification	GROVE part no.
51 (13.5)	TranSynd TES295; synthetic, Do not mix this with mineral oil!	6829101690

Designation	Quantity	GROVE part no.
Oil filter set with gaskets (contains two filters and one oil drain plug gasket)	1	03141323

- Receptacle, approx. 51 l (13.5 gal); P. 2 - 4.
- Torque wrench for torques of 25-32 Nm (18-24 lbf ft) and 50-60 Nm (37-44 lbf ft).

Prerequisites

- The gear oil must be at operating temperature (75 to 95 °C (160 to 200 °F)).
- The truck crane must be raised on outriggers or parked over an inspection pit.
- The engine must not be running and must be secured against unauthorised use; P. 2 - 3.



Changing



Risk of scalding from gear oil at operating temperature!

You could scald yourself by gear oil escaping in an uncontrolled manner at operating temperature. Wear appropriate protective gloves and take care not to come into contact with the gear oil.



Risk of environmental damage due to leaking consumables!

Always let consumables drain into suitable receptacles. Wipe up any consumables that escape. Store/dispose of consumables and any soaked equipment properly. Ask about the applicable regulations.

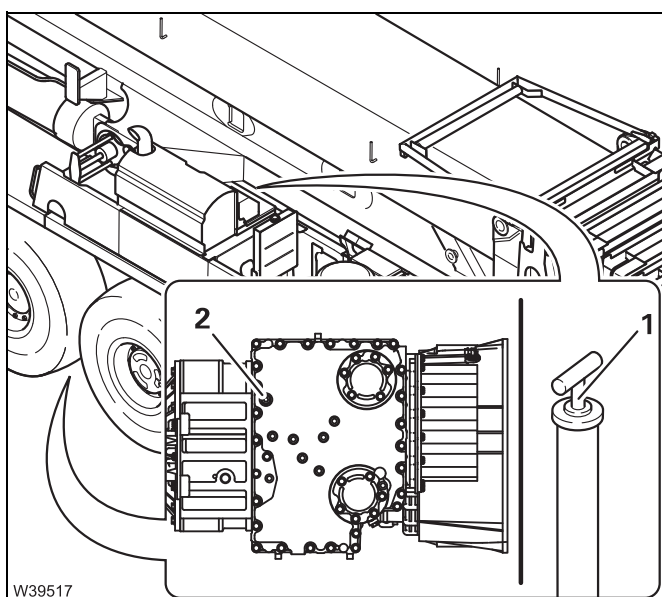

Draining oil

- Pull out the dipstick (1).
- Place a receptacle under the screw (2).
- Remove the screw and let the oil drain out.

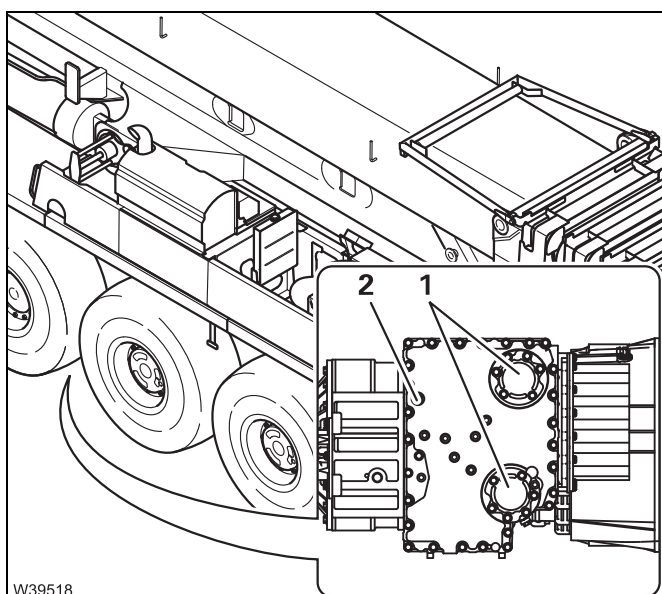

Changing the oil filter

- Release the cap (1) and pull out the filters.
- Insert new filters.
- Replace the gaskets and tighten the caps – torque 50-60 Nm (37-44 lbf ft).
- Replace the gasket and tighten the screw (2) – torque 25-32 Nm (18-24 lbf ft).

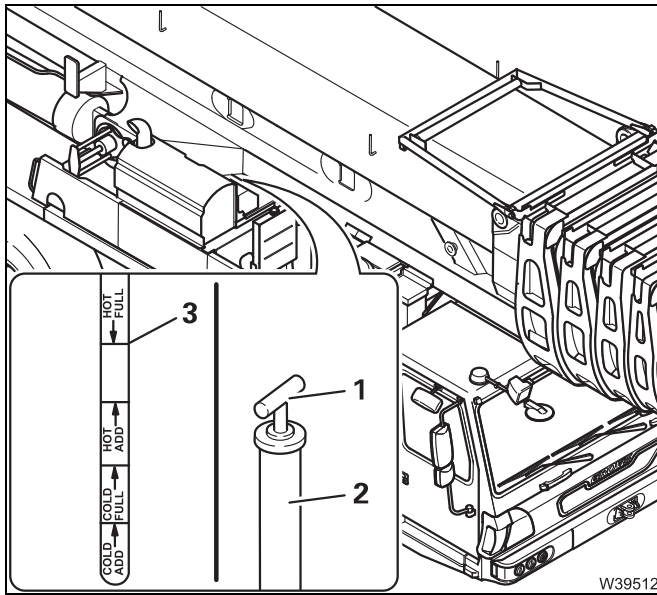

Topping up the oil

- Top up the oil via the dipstick tube (2).
- Wait so that the oil is evenly distributed in the transmission.
- Use the dipstick (1) to check whether the oil level is clearly above the mark (3), otherwise the engine may not be started.
- Insert the dipstick into the dipstick tube.
- Allow the engine to run at idling speed in the neutral position **N** so that the oil can be evenly distributed in the transmission and in the oil cooler.

Checking



- Check the oil level when the gear oil is cold; ■■■▶ P. 7 - 44.

Risk of accidents when searching for leaks under the truck crane!

Ensure that the parking brake is engaged before you go underneath the truck crane to search for leaks.
Keep away from rotating parts.

- Check the transmission for leaks on the caps of the oil filters and at the oil drain plug.
- Check the oil level when the gear oil is warm; ■■■▶ P. 7 - 45.

Blank page

7.7

Transfer case

- Also adhere to the  *Run-in regulations*, P. 4 - 1.

7.7.1

General inspection

W

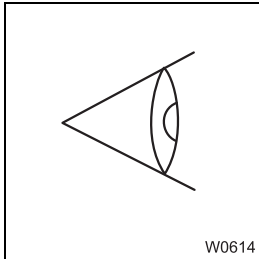

- Investigate any unusual noises made by the transfer case.
- Check the transfer case and the connections for leaks. If consumables are leaking;  *Check the oil level*, P. 7 - 51.
- Check that pipes and hoses are tightly connected and undamaged.

If any damage is found, report it to **Manitowoc Crane Care** or an authorised GROVE dealer or an authorised specialist workshop.

7.7.2

Check the oil level

M 1

Spare parts and tools

Designation	Quantity	GROVE part no.
Gasket 30 x 36 Cu DIN 7603	1	00117151

- Clean receptacle, approx. 5 l (1.3 gal);  P. 2 - 4.

Prerequisites

- The truck crane must be raised on outriggers or parked over an inspection pit.
- The engine must not be running and must be secured against unauthorised use;  P. 2 - 3.



Checking the oil level

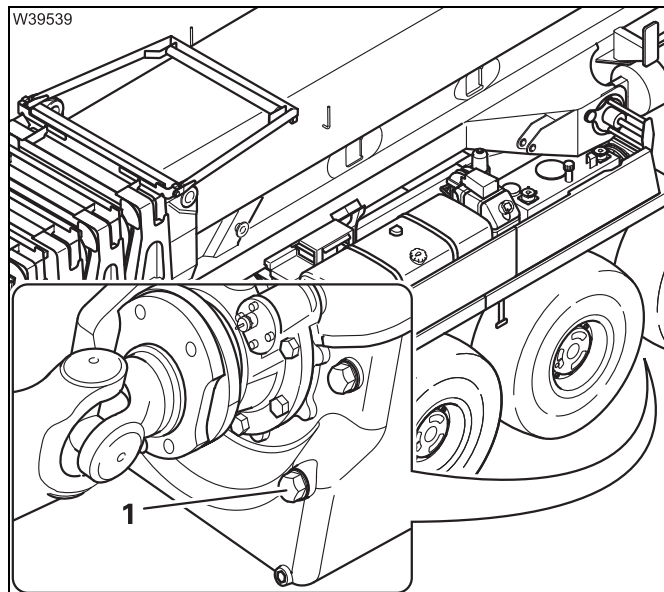

- Remove the drain plug (1).
- Check that the oil reaches the lower edge of the opening (1).
- Fit a new gasket and tighten the screw (1).

If the oil level is too low

- Top up with oil; ►► P. 7 - 53.

7.7.3

Changing the oil

M 6

Oil, spare parts, tools

Gear oil in litres (gal)	Designation to DIN 51502	Specifications Classification	GROVE part no.
12.8 (3.4) (14 x 6 drive)	C - LPF	MIL-L 2105 B API-GL-5 Viscosity: Hyp SAE 90 ISO - VG 220	00552891
11.8 (3.1) (14 x 8 drive)			

Designation	Quantity	GROVE part no.
Gasket 16 x 20 Cu DIN 7603	1	00117134
Gasket 30 x 36 Cu DIN 7603	1	00117151

– Receptacle, approx. 15 l (4.0 gal); ►► P. 2 - 4.

Prerequisites

- The truck crane must be raised on outriggers or parked over an inspection pit.
- The engine must not be running and must be secured against unauthorised use; ►► P. 2 - 3.

Changing the oil



Risk of scalding from gear oil at operating temperature!

You could scald yourself by gear oil escaping in an uncontrolled manner at operating temperature. Wear appropriate protective gloves and take care not to come into contact with the gear oil.



Risk of environmental damage due to leaking consumables!

Always let consumables drain into suitable receptacles. Wipe up any consumables that escape.

Store/dispose of consumables and any soaked equipment properly. Ask about the applicable regulations.

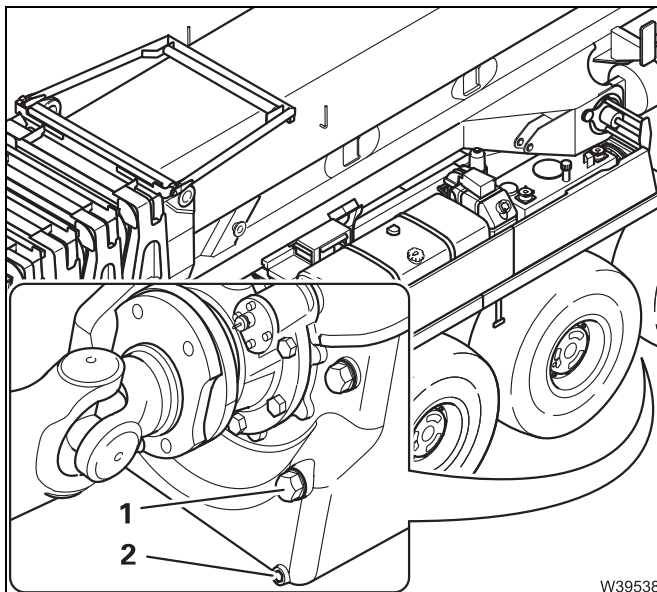

- Place a container under the screws (2).
- Unscrew bolts (1) and (2) and allow the oil to drain.
- Fit a new gasket and tighten the screw (2).
- Fill the oil up to the lower edge of the opening (1).
- Fit a new gasket and tighten the screw (1).

Inspections after an oil change

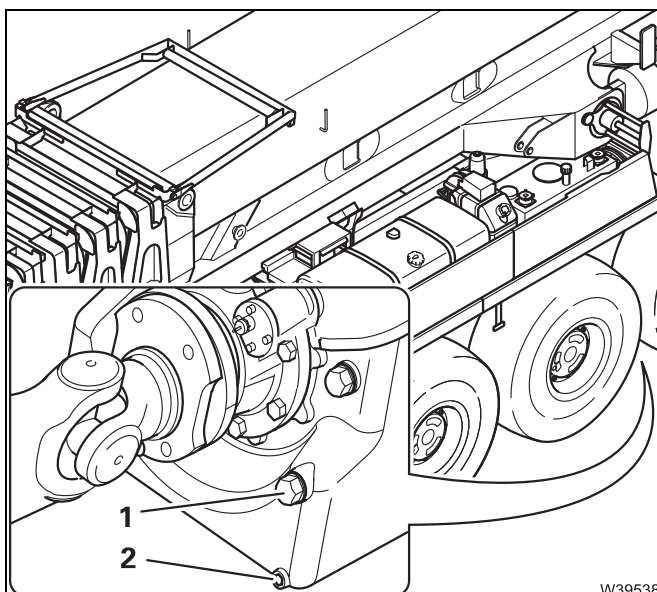

- Go for a test drive.
- Switch the engine off and wait for about 5 minutes.
- Check drain plugs (1) and (2) for leaks.

Blank page

7.8

Axle lines



- Also adhere to the  *Run-in regulations*, P. 4 - 1.

7.8.1

General inspection

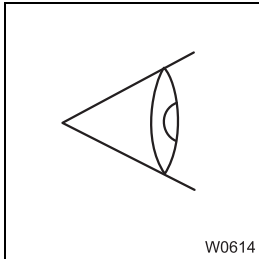
W



- Investigate any unusual running noises from the axle centre drives and the final drives.
- Check the axle centre drives/final drives and the connections for leaks. If consumables are leaking;
 -  *Axle centre drives – checking the oil level*, P. 7 - 55,
 -  *Final drives – Checking the oil level*, P. 7 - 59.
- Check that pipes and hoses are tightly connected and undamaged.

If any damage is found, report it to **Manitowoc Crane Care** or an authorised GROVE dealer or an authorised specialist workshop.

7.8.2

Axle centre drives – checking the oil level

M 1

Spare parts and tools

for drive	Designation	Quantity	GROVE part no.
14 x 6 x 14	Gasket 30 x 36 Cu DIN 7603	3	00117151
	Gasket 24 x 29 Cu DIN 7603	1	00117145
14 x 8 x 14 ¹⁾	Gasket 30 x 36 Cu DIN 7603	4	00117151
	Gasket 24 x 29 Cu DIN 7603	2	00117145

¹⁾ Additional equipment (2nd axle line driven)

Prerequisites

- The truck crane must be raised on outriggers or parked over an inspection pit.
- The engine must not be running and must be secured against unauthorised use;  P. 2 - 3.



1st and 5th axle line

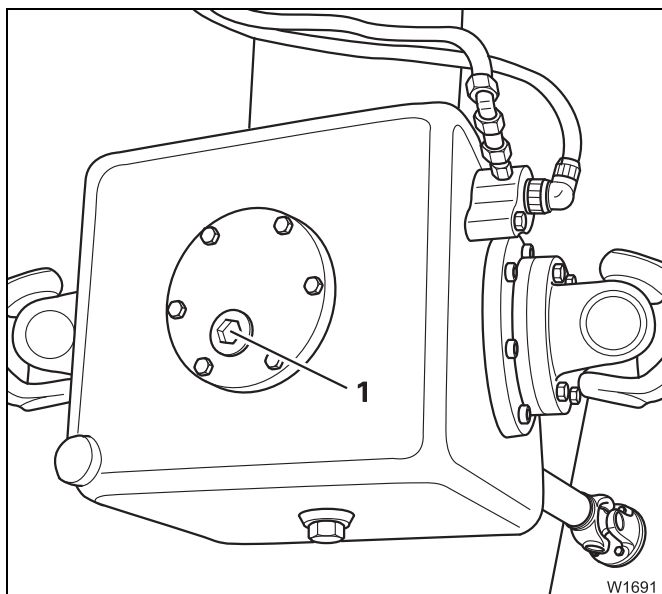

- Remove the drain plug (1).
- Check that the oil reaches the lower edge of the openings.
- Fit new gaskets and tighten the screws.

If the oil level is too low

- Top up with oil; ►► P. 7 - 58.

2nd and 4th axle line

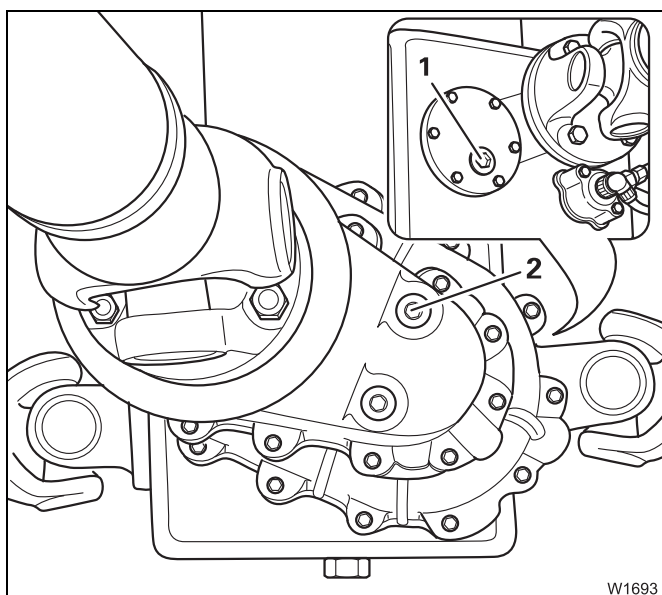

The drive has two oil chambers.

- Remove the drain plugs (1) and (2).
- Check that the oil reaches the lower edge of the openings.
- Fit new gaskets and tighten the screws.

If the oil level is too low

- Top up with oil; ►► P. 7 - 58.

7.8.3

Axle centre drives – changing the oil

M 12

Oil, spare parts,
tools

Gear oil in litres (gal)	Designation to DIN 51502	Specifications Classification	GROVE part no.
Axle line 1+5: 13.0 (3.5) each Axle line 2+4 ¹⁾ : 16.5 (4.4)	C - LPF	MIL-L 2105 B API-GL-5 Viscosity: Hyp SAE 90 ISO - VG 220	00552891

For drive	Designation	Quantity	GROVE part no.
14 x 6 x 14	Gasket 30 x 36 Cu DIN 7603	3	00117151
	Gasket 24 x 29 Cu DIN 7603	2	00117145
	Gasket 36 x 42 Cu DIN 7603	3	01371208
14 x 8 x 14	Gasket 30 x 36 Cu DIN 7603	4	00117151
	Gasket 24 x 29 Cu DIN 7603	4	00117145
	Gasket 36 x 42 Cu DIN 7603	4	01371208

¹⁾ Additional equipment (2nd axle line driven)

– Receptacle, approx. 20 l (5.0 gal);  P. 2 - 4.

Prerequisites

- The truck crane must be raised on outriggers or parked over an inspection pit.
- The engine must not be running and must be secured against unauthorised use;  P. 2 - 3.



Risk of environmental damage due to leaking consumables!

Always let consumables drain into suitable receptacles. Wipe up any consumables that escape.

Store/dispose of consumables and any soaked equipment properly.

Ask about the applicable regulations.



1st and 5th axle line

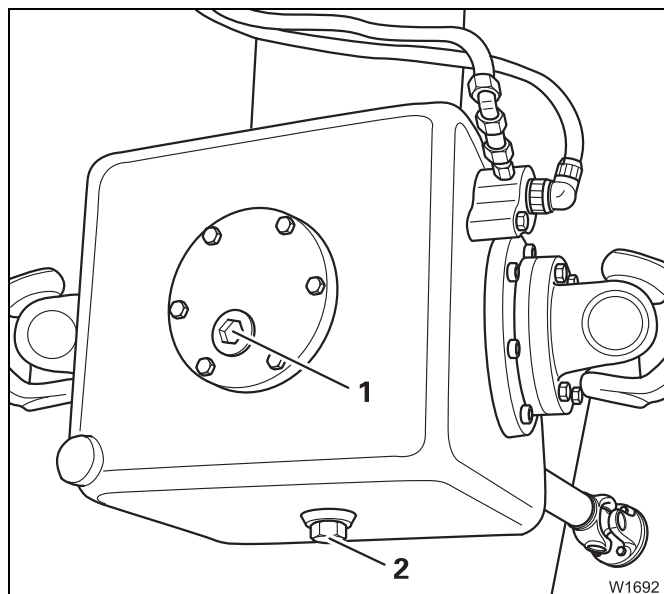

- Place a receptacle under the screw (2).
- Unscrew drain plugs (1) and (2) and allow the oil to drain.
- Fit a new gasket and tighten the screw (2).
- Fill the oil up to the lower edge of the opening.
- Fit a new gasket and tighten the screw (1).

2nd and 4th axle line

The drive has two oil chambers.



Risk of oil overheating!

When topping up the oil, both openings must be opened so that both oil tanks are filled equally. This prevents the oil tanks from being overfilled and thus the oil from overheating.

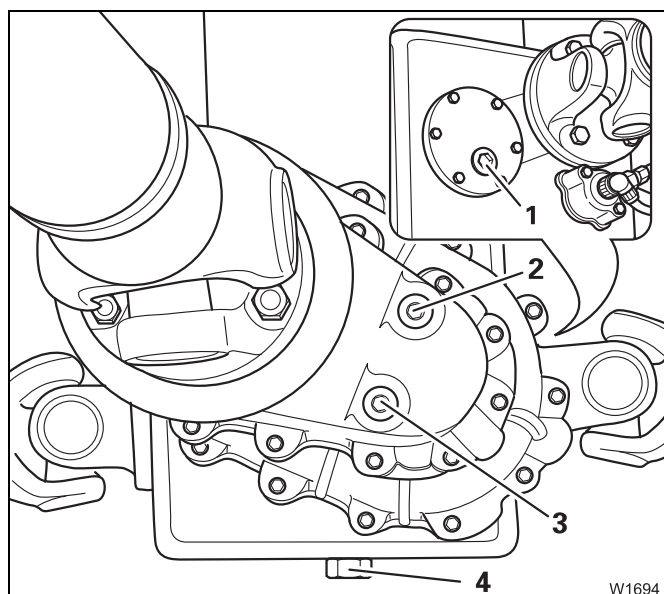

- Place a receptacle under screws (3) and (4).
- Remove the drain plugs (1), (2), (3) and (4) and let the oil drain off.
- Fit new gaskets and tighten the screws (3) and (4).
- Top up oil through opening (2) until it flows out of the opening (1).
- Fit new gaskets and tighten the screws (1) and (2).

7.8.4

Final drives – Checking the oil level

M 1

Spare parts and tools

For drive	Designation	Quantity	GROVE part no.
14 x 6 x 14	Gasket 24 x 29 Cu DIN 7603	6	00117145
14 x 8 x 14 ¹⁾	Gasket 24 x 29 Cu DIN 7603	8	00117145

¹⁾ Additional equipment (2nd axle line driven)

Prerequisites

- The truck crane must be raised on outriggers and must be level.
- The engine must not be running and must be secured against unauthorised use;  P. 2 - 3.
- The parking brake must be released.

Checking the oil level

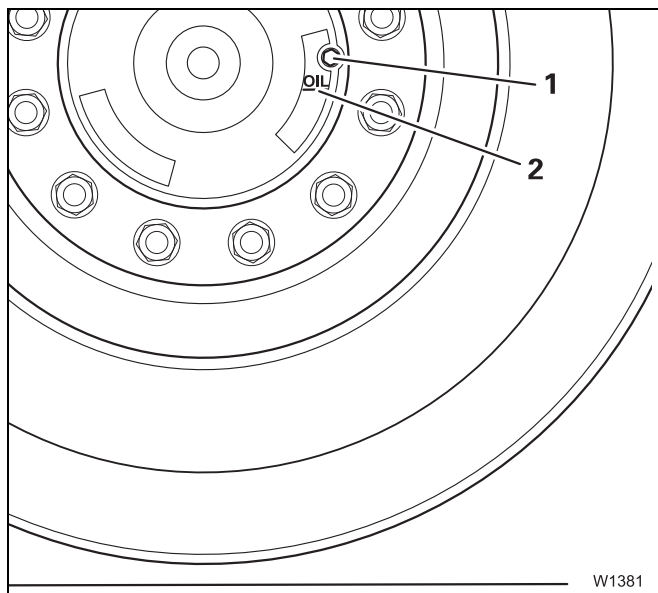

- Check the oil level at all other final drives in the same way.
- Turn the wheel until the marking (2) is horizontal and is on the right, next to the centre of the axle.
- Remove the drain plug (1).
- Check that the oil level is at the mark (2).
- Fit a new gasket and tighten the screw.

If the oil level is too low

- Top up with oil;  P. 7 - 61.

7.8.5

Final drives – Changing the oil

M 12

Oil, spare parts, tools

Gear oil in litres (gal)	Designation to DIN 51502	Specifications Classification	GROVE part no.
for each final drive: 2.7 (0.7)	C - LPF	MIL-L 2105 B API-GL-5 Viscosity: Hyp SAE 90 ISO - VG 220	00552891

For drive	Designation	Quantity	GROVE part no.
14 x 6 x 14	Gasket 24 x 29 Cu DIN 7603	6	00117145
14 x 8 x 14 ¹⁾	Gasket 24 x 29 Cu DIN 7603	8	00117145

¹⁾ Additional equipment (2nd axle line driven)

- Drain channel.
- Receptacle, approx. 5 l (1.5 gal);  P. 2 - 4.

Prerequisites

- The truck crane is raised on outriggers.
- The engine must not be running and must be secured against unauthorised use;  P. 2 - 3.
- The parking brake must be released.



Risk of environmental damage due to leaking consumables!

Always let consumables drain into suitable receptacles. Wipe up any consumables that escape.

Store/dispose of consumables and any soaked equipment properly.

Ask about the applicable regulations.

Draining oil

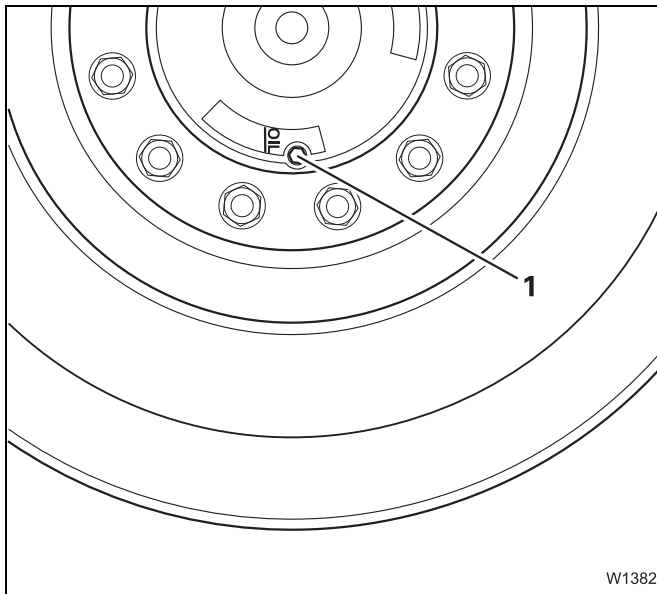

- Change the oil on all final drives in the same way.
- Turn the wheel until the bolt (1) is at the bottom.
- Use a drain channel and place a receptacle under the screw.
- Remove the screw and let the oil drain out.

Topping up the oil

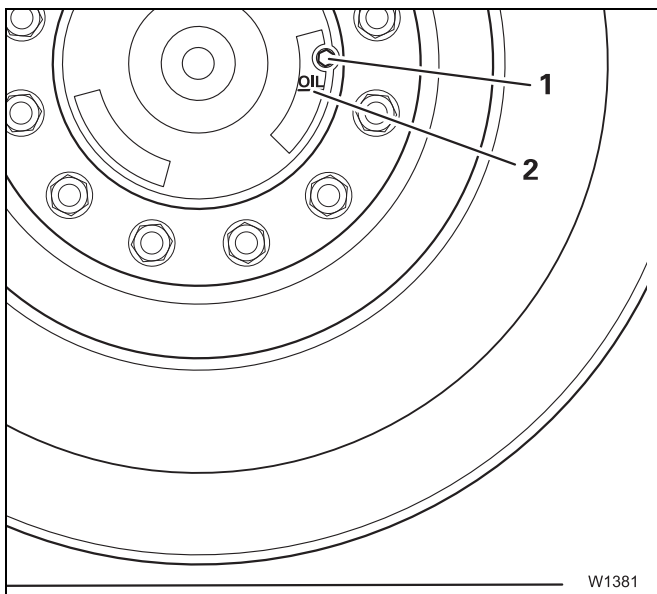

- Turn the wheel until the marking (2) is horizontal and is on the right, next to the centre of the axle.
- Top up the oil through the opening.
- Fit a new gasket and tighten the screw (1).

7.8.6

Lubricating the drive shafts in the axle lines

M 1



Check all drive shafts to see if they have grease nipples. drive shafts with grease nipples must be serviced, drive shafts without grease nipples are maintenance-free.

Grease, spare parts, tools

Lubricating grease	Designation to DIN 51502	Specifications Classification	GROVE part no.
Grease	KP - 1K - 50	DIN 51825	03233369

- Grease gun from the tool set.

Prerequisites

- The truck crane must be raised on outriggers or parked over an inspection pit.
- The engine must not be running and must be secured against unauthorised use; P. 2 - 3.
- The wheels must be turned as far as they will go, so that the lubricating nipples on the sides of the final drives are more easily accessible.

Greasing

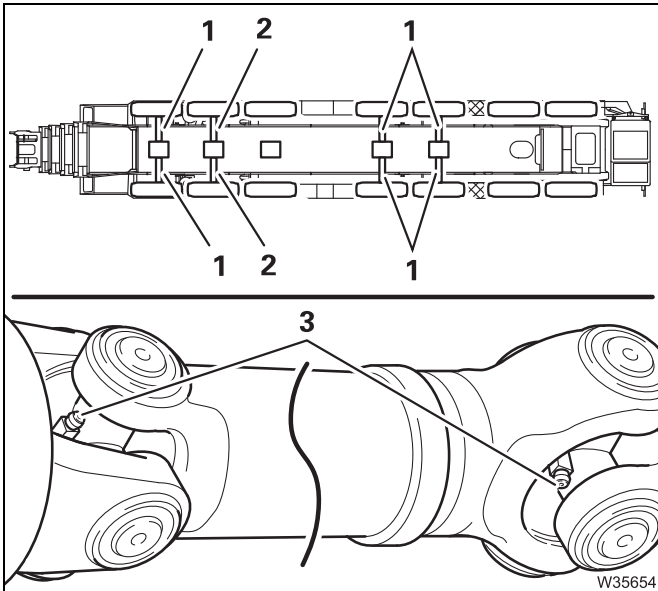

Drive shafts (2) are fitted only to the 14 x 8 x 14 drive.

- Check which drive shafts (1) and (2) have lubricating nipples (3).
- Clean the grease nipples (3).
- Inject grease into the grease nipples until grease escapes from the bearing points. Do not inject grease with excessive force, otherwise the lip seals may be damaged.
- Remove any grease that has escaped.

7.8.7

Lubricating longitudinal drive shafts

M 6



Check all drive shafts to see if they have grease nipples. drive shafts with grease nipples must be serviced, drive shafts without grease nipples are maintenance-free.

Grease, spare parts, tools

Lubricating grease	Designation to DIN 51502	Specifications Classification	GROVE part no.
Grease	KP - 1K - 50	DIN 51825	03233369

- Grease gun from the tool set.

Prerequisites

- The truck crane must be raised on outriggers or parked over an inspection pit.
- The engine must not be running and must be secured against unauthorised use; ► P. 2 - 3.

Greasing

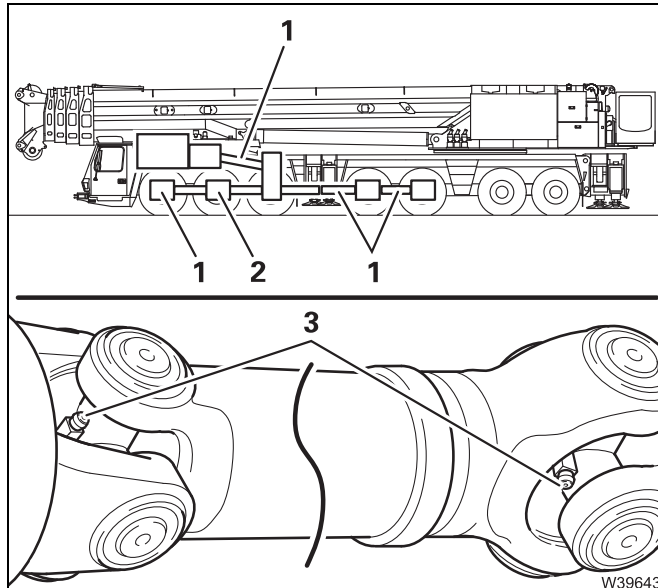

Drive shafts (2) are fitted only to the 14 x 8 x 14 drive.

- Check which drive shafts (1) and (2) have lubricating nipples (3).
- Clean the grease nipples (3).
- Inject grease into the grease nipples until grease escapes from the bearing points. Do not inject grease with excessive force, otherwise the lip seals may be damaged.
- Remove any grease that has escaped.

Blank page

7.9

Wheels

7.9.1

Checking the tyres for damage

D

Prerequisites

- The truck crane is raised on outriggers.
- The engine must not be running and must be secured against unauthorised use;  P. 2 - 3.
- The parking brake must be released.

Checking

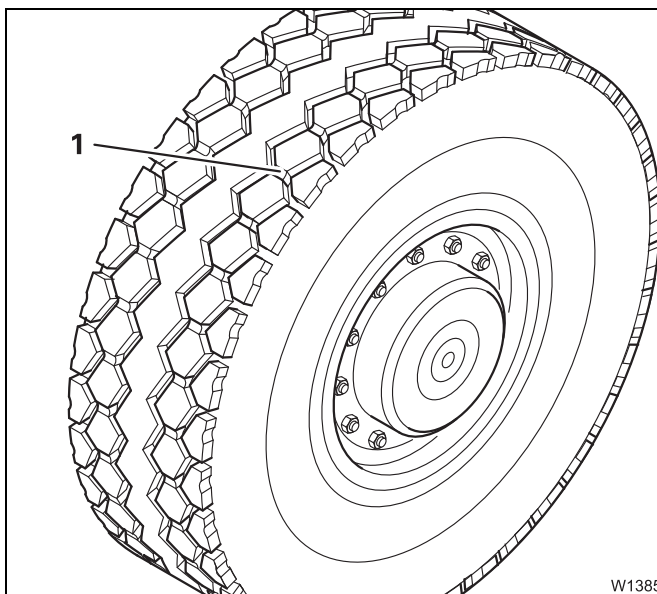

- Check all tyres for:
 - Broken off tread blocks,
 - Dents,
 - Areas of uneven wear,
 - Whether the wear mark (1) has been reached.
- Replace any damaged tyres.
- If the tyres show varying degrees of wear, change the wheels;  *Changing the wheels*, P. 7 - 68.



Risk of accidents due to uneven braking!

When replacing the tyres, only use the same quality of tyres as those originally fitted (dimensions, load bearing capacity, air pressure) so that the driving characteristics are maintained.

Always replace all the tyres on an axle line.

7.9.2

Checking the tyre pressure

W



Risk of damage to the tyres!

The air pressure increases when the tyres become hot during driving.
Never release the increased air pressure of tyres at operating temperature!
Always check the air pressure in on-road driving mode with cold tyres.

- Check the air pressure using the following table.

Tyres	Air pressure in bar (psi) with cold tyres
14.00 R 25	10.0 (145)
14.00 R 25 X Crane	9.0 (131)
16.00 R 25	9.0 (131)
17.50 R 25	7.0 (102)
20.50 R 25	7.0 (102)
385/95 R 25	10.0 (145)
445/80 R 25	7.0 (102)
445/95 R 25	9.0 (131)
525/80 R 25	7.0 (102)

7.9.3

Checking that the wheel nuts are tight

M 1

Spare parts and tools

Designation	Quantity per wheel	GROVE part no.
Wheel nut with pressure plate for steel rims	12	01207756
Wheel nut with pressure plate for aluminium rims	12	7659100000

– Torque wrench for 650 Nm (480 lbf ft).

Prerequisites

– The engine must not be running and must be secured against unauthorised use;  P. 2 - 3.

Check the wheel nuts

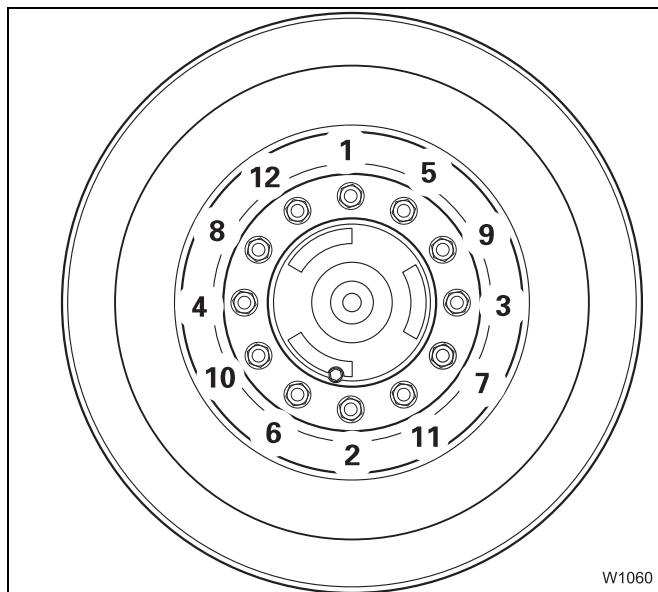

- Check the wheel nuts and the pressure plates for damage.
- Replace any damaged wheel nuts or pressure plates.
- Check the wheel nuts in the sequence (1-12) for a tight fit – torque 650 Nm (480 lbf ft).

7.9.4

Changing the wheels

M 6

The wear on tyres varies depending on whether the axle

- is driven/not driven,
- is steered/not steered,
- is braked/not braked,
- and whether it is subject to more or less load.

To achieve even wear, you must swap the wheels to different positions regularly.

This will have a positive effect on tyre life and performance.

Spare parts and tools

Designation	Quantity per wheel	GROVE part no.
Wheel nut with pressure plate for steel rims	12	01207756
Wheel nut with pressure plate for aluminium rims	12	7659100000

- Torque wrench for 650 Nm (480 lbf ft).

Prerequisites

- The engine must not be running and must be secured against unauthorised use;  P. 2 - 3.

Changing the wheels



Risk of accidents if the procedure is not carried out correctly!

This section only shows the sequence to be followed when changing wheels.

When removing/installing the wheels, observe all the safety instructions and the procedure stated in the operating manual.

- Remove the wheels from the axles.

Only for two-piece aluminium rims

- Have a specialist workshop check the bolts on the two-piece aluminium rims, using the appropriate special tool.

Depending on the manufacturer, there are 20 or 22 bolts visible on the outer face of the wheel rim. On the inner face of the wheel rim there are 20 or 22 nuts and the torque of these must be checked in a specialist workshop;  *Recognising two-piece aluminium rims*, P. 7 - 69.

Recognising two-piece aluminium rims

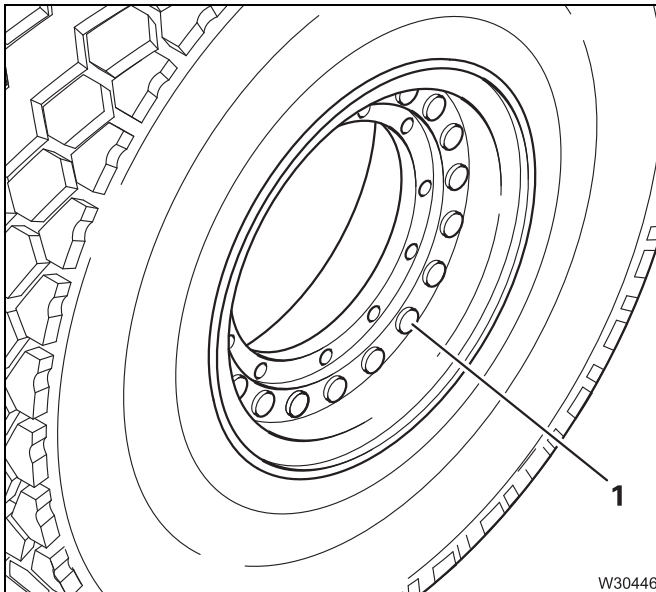

The round-head bolts (1) are on the outer face of the wheel rim.

The round heads must be free of cracks, and the bolts must be seated securely in the bores.

Around the edge of the aluminium rim there are impressed marks and safety instructions which must be complied with by the specialist workshop.

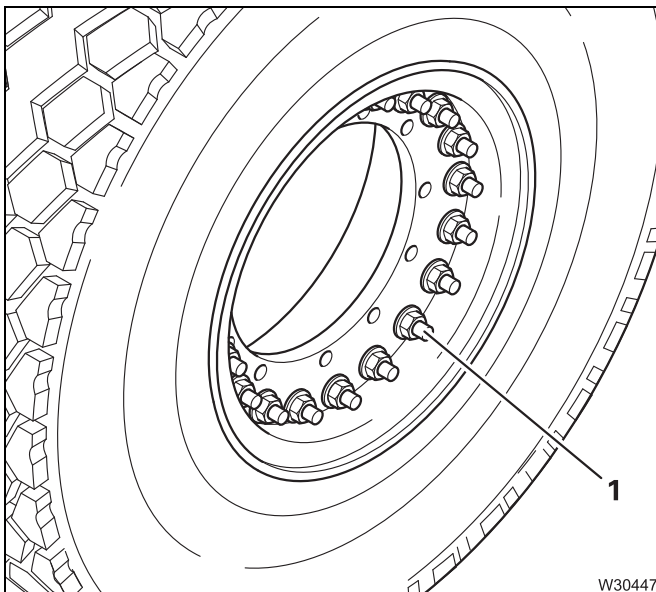

The nuts (1) are on the inner face of the wheel rim.

The round heads must be free of cracks and securely seated on the bolts. The torque must be checked within the specialist workshop.

Aluminium rims with 20 nuts:

550 Nm (406 lbf ft)

Aluminium rims with 22 nuts:

385 Nm (284 lbf ft)



- Mount the wheels on another axle, as shown in the diagram. Replace any damaged parts. Tighten the wheel nuts;  P. 7 - 67.

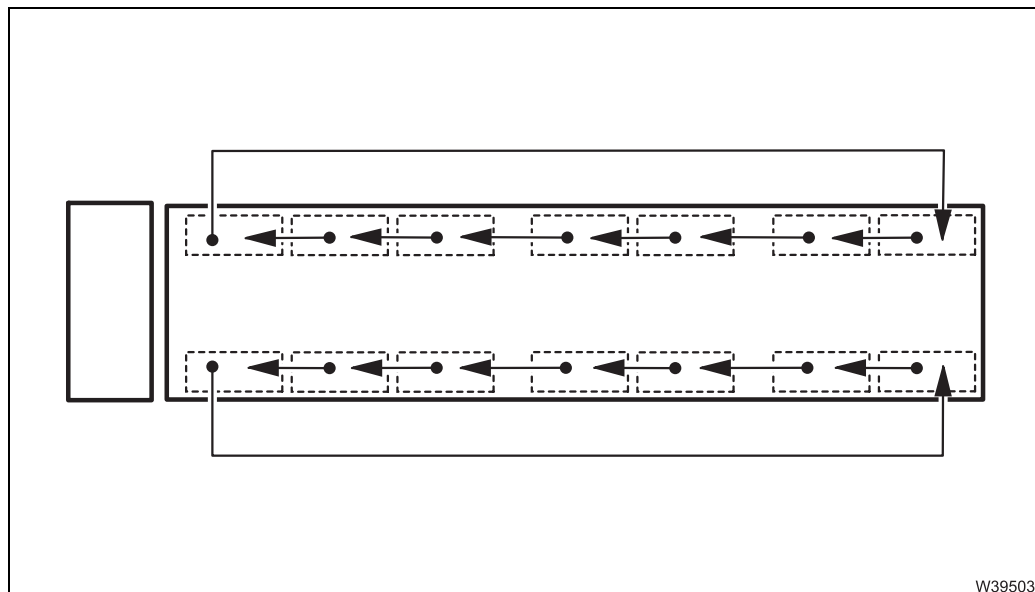

Optimised wheel changes

To ensure even more even wear on all tyres, you can also rotate the tyres on the wheel rim and mount them on the other side of the vehicle.



Risk of accidents if the procedure is not carried out correctly!

This section only shows the sequence to be followed when changing wheels.

When removing/installing the wheels, observe all the safety instructions and the procedure stated in the operating manual.



Risk of accidents due to errors when mounting aluminium wheel rims!

Only have tyres fitted to aluminium wheel rims in an authorised workshop with the correct special tool.

This will prevent tyre damage caused by assembly errors.



Risk of tyre damage caused by the tyres running in a different direction!

Turn the tyres on the wheel rims before you put the wheels on the other side of the vehicle.

This will prevent tyre damage caused by the tyres running in a different direction.

- Remove the wheels from the axles.
- Turn the tyre on the wheel rim if the wheel is to be used on the other side of the crane.
- Mount the wheels on another axle, as shown in the diagram. Replace any damaged parts. Tighten the wheel nuts;  P. 7 - 67.

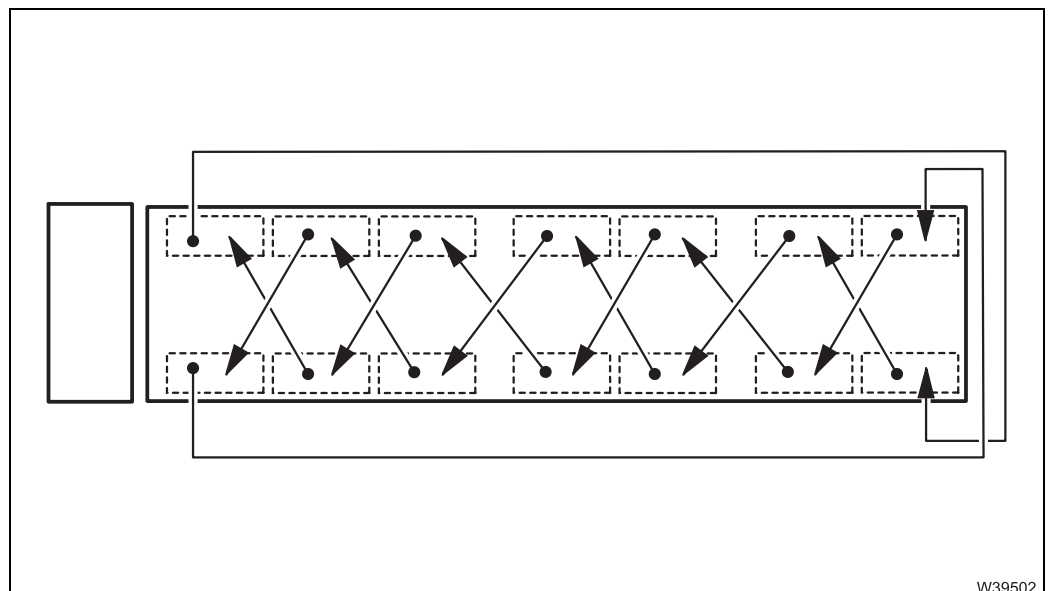

Blank page

7.10 Vehicle brake

7.10.1 Checking brake lining thickness

M 3

Spare parts and tools

Designation	Quantity per axle line	GROVE part no.
1st and 2nd axle line (duplex brake)		
Brake shoe with brake lining	4	03322112
Spring	4	03322110
Brake drum	2	01925703
3rd, 4th, 5th, 6th and 7th axle line (simplex brake)		
Brake shoe with brake lining	4	03322121
Spring	4	02315393
Brake drum	2	01925703

– Measuring tool for brake linings.



Prerequisites

- The truck crane is parked over an inspection pit.
- The truck crane is raised on outriggers.
- The engine must not be running and must be secured against unauthorised use; ■■■► P. 2 - 3.
- The parking brake must be released.

Safety instructions

- **Do not perform repair work** on the vehicle brakes; ■■■► *Maintenance instructions*, P. 1 - 2.



Risk of accidents due to incorrect work on the vehicle brakes!

Incorrect work on the vehicle brakes can lead to failure of the brakes causing severe accidents.

Incorrect work invalidates the operating approval of the truck crane and no claims of liability for damage can then be accepted.

All repair work on the vehicle brakes may only be performed by **Manitowoc Crane Care** or an authorised GROVE dealer or an authorised specialist workshop with specially trained repair crew.

- Perform **only maintenance work**; ■■■► *Checking*, P. 7 - 74.

Checking

- Check the thickness of the brake linings on all axle lines.

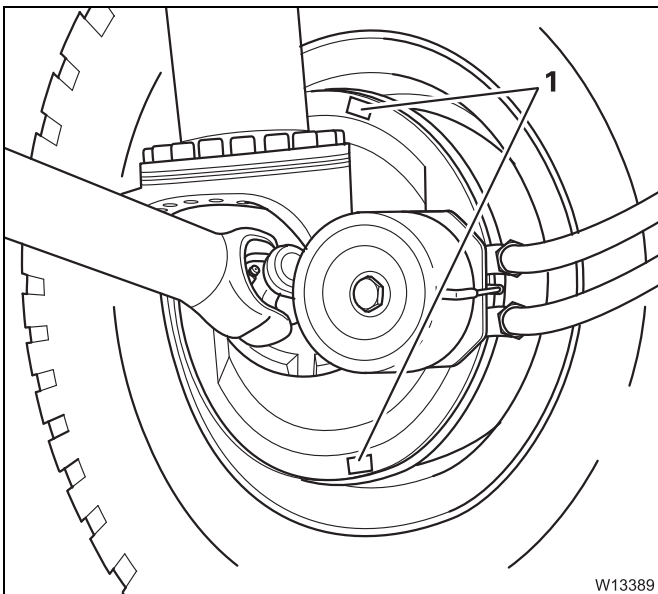



- Check the brake lining thickness from the inside at the openings (1).

If the brake lining thickness has worn down to the wear marks (stepped edges or grooves), **or** if the brake lining thickness has worn down to only 6 mm (0.25 in).

- Have the brake lining replaced; ■■■► *Having repairs performed*, P. 7 - 75.
- Close the openings using the covers.

Having repairs performed

- **Do not perform repair work** on the vehicle brakes;  *Safety instructions*, P. 7 - 74.
- All repair work on the vehicle brakes may only be performed by **Manitowoc Crane Care** or an authorised GROVE dealer or an authorised specialist workshop with specially trained repair crew.
- Make sure that only original spare parts are used;  *Spare parts and tools*, P. 7 - 73.



Risk of accidents due to uneven braking.

If the brake linings are only replaced on one side of the axle line then the wheels have an uneven braking force.
Always have the brake linings replaced on both ends of the axle line.

Allow the brakes to run in

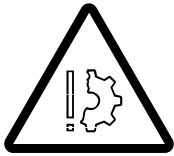

New brake linings do not provide optimal braking and must therefore be run in by periodic braking.

Risk of damage to the brakes when running them in!

Constant or heavy braking at high speeds can overheat the brakes and damage them.

The brakes must only be run in through periodic braking.

This must first be done at low speed and then later at medium speed.

- Perform a test drive to make sure that the new brake pads are sufficiently run in before putting the truck crane into normal operation.

Blank page

7.11 Suspension

7.11.1 Suspension struts – Checking the oil level

M 1

Oil, spare parts,
tools

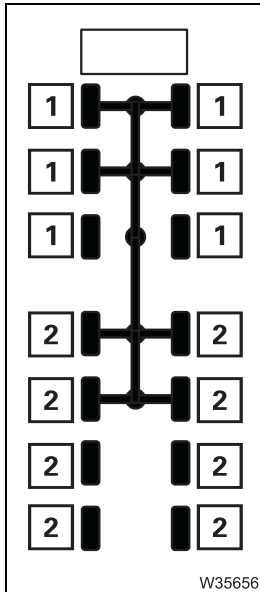

Oil in litres (gal)	Designation	GROVE part no.
6 x suspension struts (1) 1.5 (0.4) each	Rivolta S.K.D. gear oil 170	02310863
8 x suspension struts (2) 3.2 (0.84) each		

– Press with connected hose (from the toolbox).

Prerequisites

- The engine must not be running and must be secured against unauthorised use; P. 2 - 3.
- Immediately before the inspection, the truck crane must be completely lowered and returned to *on-road level*; *Operating manual*.

Checking the oil level



Risk of damage due to faulty suspension struts!

If the oil level is above the upper marking on the sight glass, the suspension strut is faulty and must be replaced.

Notify **Manitowoc Crane Care** or an authorised GROVE dealer.



Risk of damage to the suspension struts due to insufficient lubrication!

It is difficult to inject the oil. Do not fill oil through the inspection glass connections. If you do this, the oil will not reach all the lubricating points.



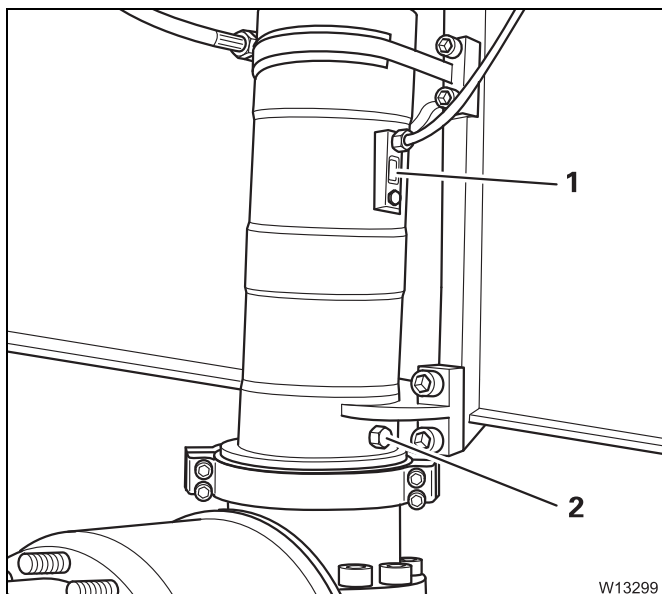

- Check whether oil is visible in the middle of the inspection glass (1) on each suspension strut.

If the oil level is too low

- Open the connection (2) – oil escapes – and quickly connect the press with the hose.
- Inject oil until it reaches the middle of the sight glass.
- Remove the hose and quickly close the connection (2).

7.11.2

Suspension struts – checking the fastening

M 1

Spare parts and tools

- Torque wrench for torques up to 900 Nm (664 lbf ft).

Prerequisites

- The truck crane is raised on outriggers; *Operating manual*.
- The engine must not be running and must be secured against unauthorised use; P. 2 - 3.
- The wheels must have been removed.

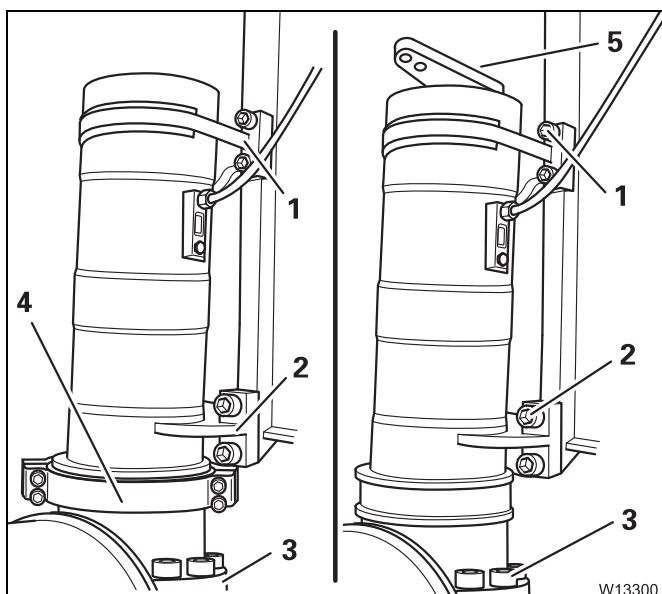

- Check whether the screws on all suspension struts are fitted tightly; *Special torques*, P. 10 - 2:

- 1 on the upper bracket,
- 2 on the lower bracket,
- 3 on the lower flange,
- 4 on the half shells for the steering arm,
- 5 on the upper steering arm.

7.11.3

Forced lever – checking correct functioning

M 3

On suspension struts with forced levers, the forced levers must be checked for proper functioning when the suspension is switched on and off.



Risk of crushing when releasing the suspension locking system!

When the suspension is switched on, the wheels drop down suddenly. Ensure that nobody is in close proximity to the wheels when you switch on the suspension.



Risk of damage to the tyres!

Remove sharp-edged or pointed objects from below the wheels before switching on the suspension. In this way you prevent the tyres from bursting or being damaged when the wheels come down.

- Start the engine.
- Lower the truck crane to the lowest level with the level adjustment system; *Operating manual*.
- Switch off the suspension; *Operating manual*.

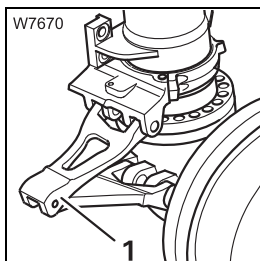
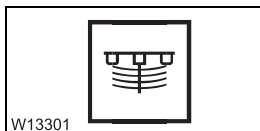

The suspension struts and the forced levers (1) are brought together.

- Raise the truck crane with the outriggers; *Operating manual*.
- Switch on the suspension; *Operating manual*.

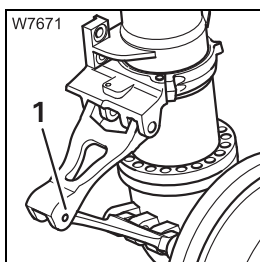
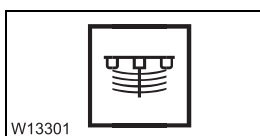

- Check whether all suspension struts are extended and the forced levers (1) are slackened.

If the suspension struts are not extended or only partially extended, the forced lever is faulty.

- Faulty forced levers should be replaced as soon as possible by **Manitowoc Crane Care** or an authorised GROVE dealer or your qualified repair crew.

7.11.4

Pressure accumulator – checking the gas pressure

M 12

The gas pressure must be checked every 3,000 operating hours, but in any case no less frequently than every 12 months.



Risk of accidents due to incorrect inspection!

The gas pressure test must be carried out only by an authorised official inspector of pressure tanks or under his/her supervision or instructions.

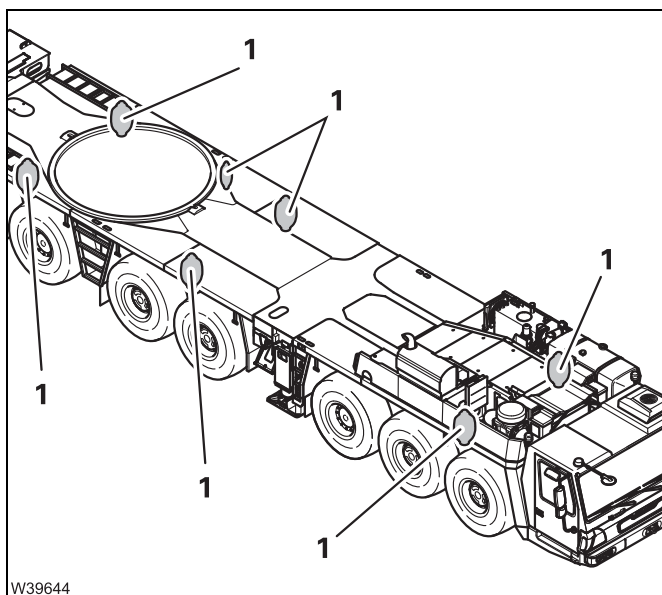

The suspension features integrated pressure accumulators that contain nitrogen (1).

The filling pressure at 20 °C (68 °F) is 40 bar (580 psi).

- Have the filling pressure checked, and if necessary corrected, by **Manitowoc Crane Care** or an authorised GROVE dealer or an authorised specialist workshop.

W39644

7.12

Steering

7.12.1

Checking for leaks

D

- Check the hydraulic system of the steering (steering cylinders, pipes and hose lines and their connections) for leaks.



Risk of accidents from hydraulic oil spraying out!

Never tighten leaking connections when the system is under pressure.
Change pipes and hose lines only when the system is depressurised.

- Top up the oil if necessary;  *Check the oil level, P. 7 - 87.*

After changing pipes and hose lines

- Bleed the hydraulic system;  *Bleeding the hydraulic system, P. 7 - 100.*

If damage cannot be rectified immediately or further damage is likely

- Notify **Manitowoc Crane Care** or an authorised GROVE dealer or your repair crew.

Blank page

7.13 Compressed air system



7.13.1 Draining water from the compressed air system

W

Spare parts and tools

Designation	Quantity	GROVE part no.
Valve	6	01570750
Gasket 22 x 27 Cu DIN 7603	6	00117142

Prerequisites

- The truck crane must be raised on outriggers or parked over an inspection pit.
- The compressed-air supply is completely full;  *Operating manual*.
- The engine must not be running and must be secured against unauthorised use;  P. 2 - 3.

Draining water from the compressed air system

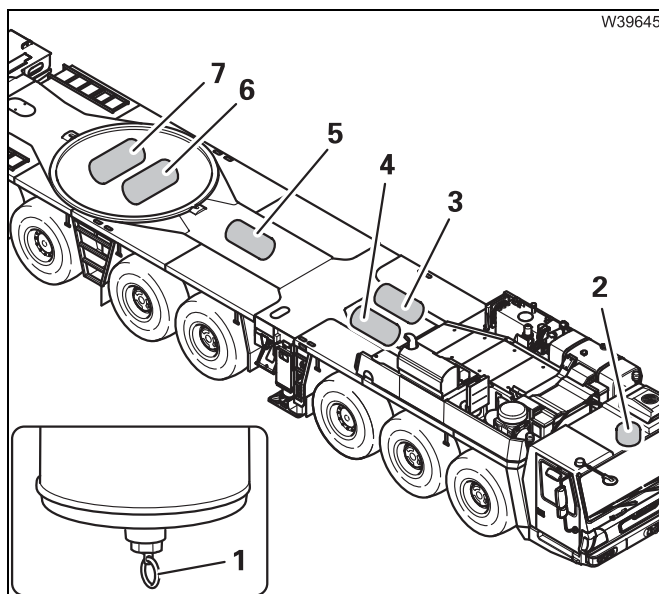

- Actuate the valves (1) on the air reservoirs (2) to (7).

If a great deal of water escapes

- Have the compressed air drier checked or replaced by **Manitowoc Crane Care** or an authorised GROVE dealer or your qualified repair crew.

7.13.2

Checking for leaks

W

- Start up the compressed air system.
- Check for any possible leaks in the compressed air system (connections, pipes, hose lines and valves).



Risk of accidents due to escaping compressed air!

Never tighten connections when the system is under pressure. Only change gaskets, pipes and hose lines when the system is depressurised.

If damage cannot be rectified immediately or further damage is likely:

- Notify **Manitowoc Crane Care** or an authorised GROVE dealer or your repair crew.

7.13.3

Replacing the filter cartridge of the compressed air drier

M 12

Spare parts and tools

Designation	Quantity	GROVE part no.
Filter cartridge	1	04156032

- Strap wrench.

Prerequisites

- The truck crane must be raised on outriggers or parked over an inspection pit.
- The engine must not be running and must be secured against unauthorised use; ► P. 2 - 3.

Changing the filter cartridge



Risk of injury from escaping compressed air!

If the reservoir (2) is not completely vented, the compressed air drier will be under pressure.

Bleed the reservoir until air no longer escapes from the valve.

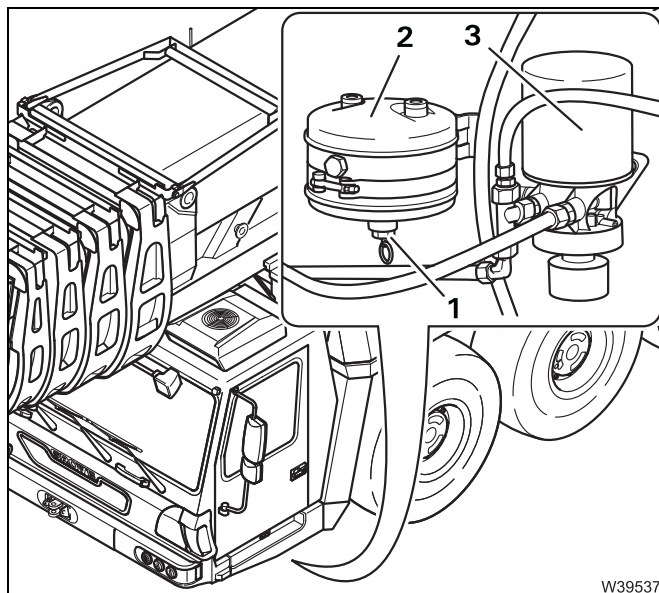

- Using the valve (1), bleed all the air from the reservoir (2).
- Replace the filter cartridge (3) using the strap wrench (lubricate gasket slightly).

Blank page

7.14

Hydraulic system



Risk of environmental damage due to leaking consumables!

Always let consumables drain into suitable receptacles. Wipe up any consumables that escape.

Store/dispose of consumables and any soaked equipment properly.

Ask about the applicable regulations.

7.14.1

Check the oil level

D

Prerequisites

- The truck crane must be aligned horizontally at on-road level; *Operating manual*.
- The outriggers are retracted; *Operating manual*.
- The engine must not be running and must be secured against unauthorised use; P. 2 - 3.

Check the oil level



Risk of damage to the hydraulic system!

When working with hydraulic oil, cleanliness is imperative!
Even fresh hydraulic oil should be filtered.

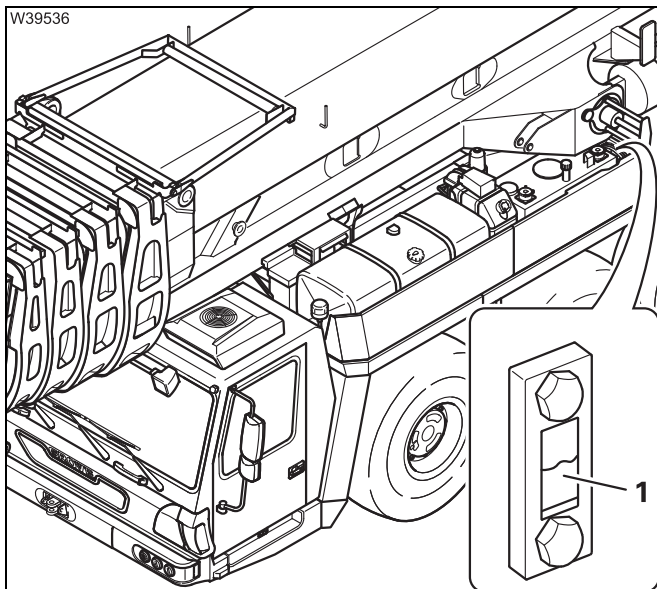

- Check that oil is visible in the middle of the sight glass (1) before starting work.

If the oil level is too low

- Top up with oil; P. 7 - 99.

7.14.2

Checking the hydraulic hoses

W

Hydraulic hoses are also subject to ageing as well as internal and external strain.

- Check the hydraulic hoses for
 - external damage (tears, abrasion, heat damage, chemical damage),
 - leaks and moist areas,
 - blistering or unevenness of hose casing,
 - signs of ageing (porous surface, rust on hose fittings).

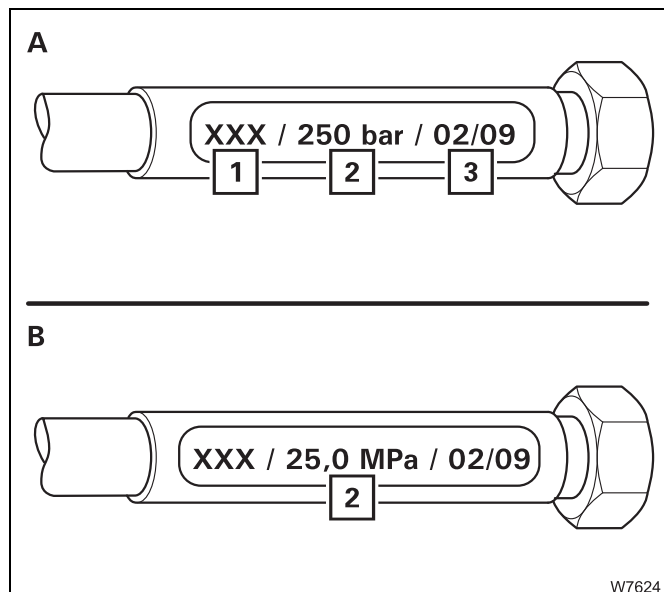

Hydraulic hoses should not be used for longer than 72 months from date of manufacture. The date of manufacture and the permitted operating pressure are marked on the hose fitting:

- 1 Manufacturer's designation.
- 2 Maximum operation pressure and unit of measurement (**A**) (e.g. 250 bar (3626 psi)).
Maximum operation pressure and unit of measurement (**B**) (e.g. 25.0 MPa (3626 psi)).
- 3 Month and year of manufacture.



- Always ensure that the corresponding parts of the hydraulic system are depressurised.
- Damaged or old hydraulic hoses must be replaced immediately.

7.14.3

Checking for leaks

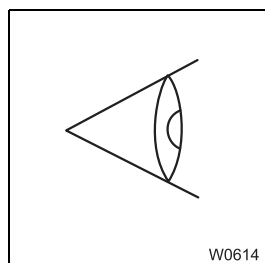
W



- When the engine is running, carry out a visual inspection for leaks on the hydraulic system (pumps, drives, cylinders, control blocks, valves, pipe and hose lines and connections).
- Check the hydraulic oil cooler for dirt;  *Have the radiator checked/cleaned, P. 7 - 19.*
- Check the oil level if there are leaks;  *Check the oil level, P. 7 - 87.*



Risk of accidents from hydraulic oil spraying out!

Never tighten any leaking connections when the system is under pressure. Change pipes and hose lines only when the system is depressurised.



Risk of environmental damage due to leaking consumables!

Immediately repair leaks in the hydraulic system or have them repaired to ensure that no hydraulic oil escapes, seeps into the ground or reaches waterways when the crane is used.

After parts have been changed

- Bleed the carrier's hydraulic system; *Bleeding the hydraulic system*, P. 7 - 100.

If damage cannot be rectified immediately or further damage is likely

- Notify **Manitowoc Crane Care** or an authorised GROVE dealer or your repair crew.

7.14.4

Cleaning the magnetic rods

M 3

Spare parts and tools

Designation	Quantity	GROVE part no.
Filter	2	03329152
Packing set	2	03135778

- Receptacle, approx. 5 l (1.5 gal); P. 2 - 4.

Prerequisites

- The truck crane must be standing on a level surface.
- The engine must not be running and must be secured against unauthorised use; P. 2 - 3.
- During the first 100 operating hours: Clean the magnetic rods weekly.



Cleaning the magnetic rods

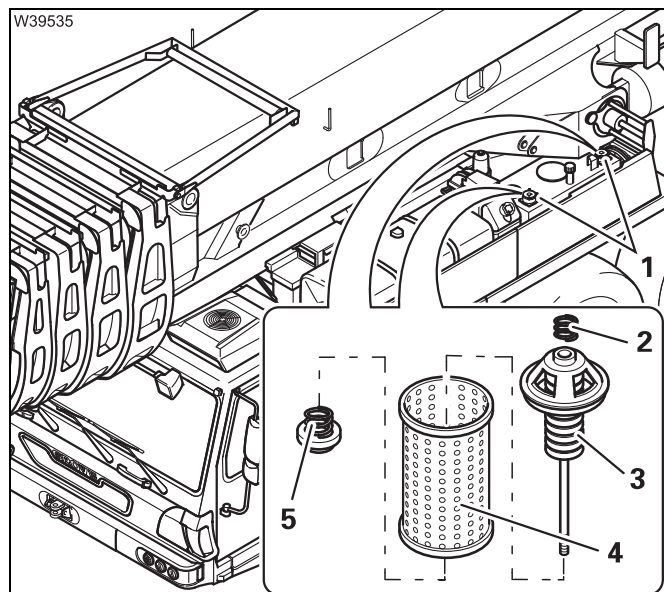

- Release the cap (1) and pull out the filters.
- Place the filters in a receptacle.
- Remove the spring (2).
- Remove the nuts (5).
- Take the magnetic rod (3) out of the filter cage (4) and clean it.
- Replace any damaged parts, if necessary.



Risk of damage to the hydraulic system!

Large amounts of metal particles are a sign of damage in the hydraulic system. Have the hydraulic system checked by **Manitowoc Crane Care** or an authorised GROVE dealer or your repair crew.

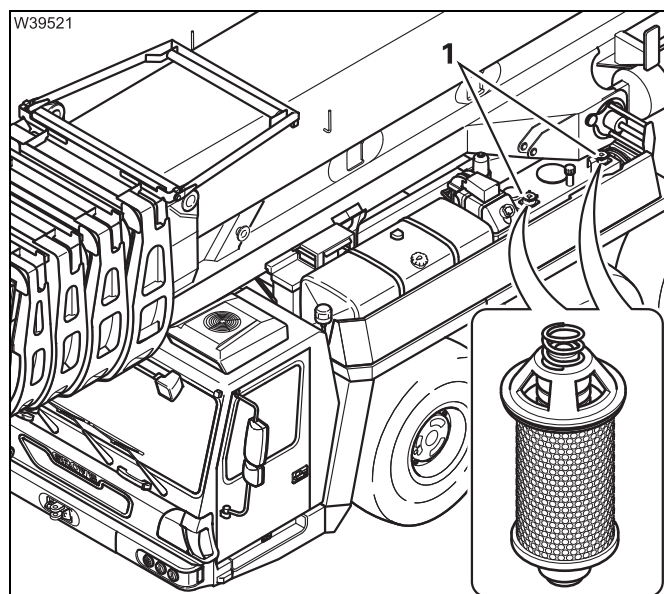

- Assemble the filters and install them.
- Replace the gaskets if necessary and fasten the cap (1).
- Start the engine and check for leaks.

7.14.5

Changing the ventilation filter

M 12

Reducing the interval

- Under difficult operating conditions – at extremely sandy or dusty locations – you must change the ventilation filters earlier than normal.

Spare parts and tools

Designation	Quantity	GROVE part no.
Filter	1	01576026

Prerequisites

- The engine must not be running and must be secured against unauthorised use;  P. 2 - 3.



Risk of damage to the environment from filter residues!

Store used hydraulic oil filter inserts in suitable receptacles and have them disposed of properly by qualified personnel.

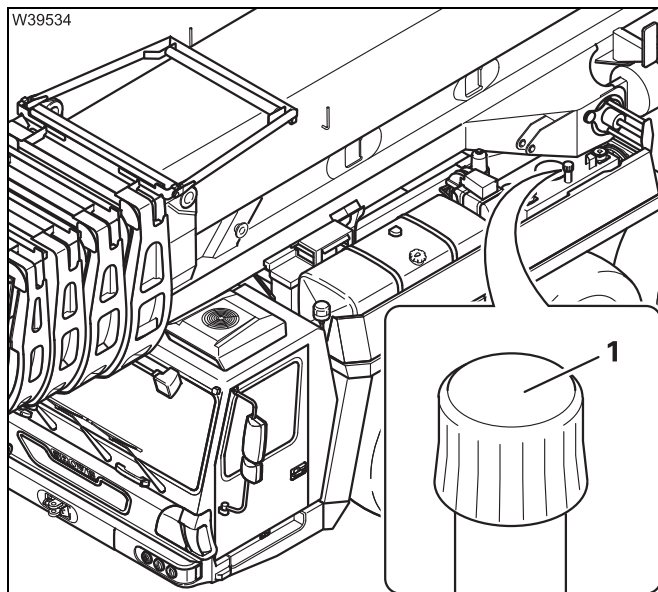

- Change the filter (1).

7.14.6

Taking oil samples

M 12

Reducing the interval

- Under difficult operating conditions – at tropical or very hot locations – you must halve the oil change interval.

Spare parts and tools

- A hose with a connecting piece for a gauge port.

Hose lengths	GROVE part no.
1 m (3.3 ft)	01923003
2 m (6.6 ft)	00551941
4 m (13.2 ft)	01923139

- A sample container 0.3 litres (0.08 gal).

	GROVE part no.
One set of sample containers with a protective mailing bag and delivery note to the contracted laboratory	03141012

- Receptacle, approx. 5 l (1.5 gal);  P. 2 - 4.

Prerequisites

- During the oil test the engine must be switched off and be secured against unauthorised use;  P. 2 - 3.

Select the sampling location

To determine the usability of the oil, you must take a sample from the hydraulic system. To do that you must connect the hose with the connecting piece to a gauge port.

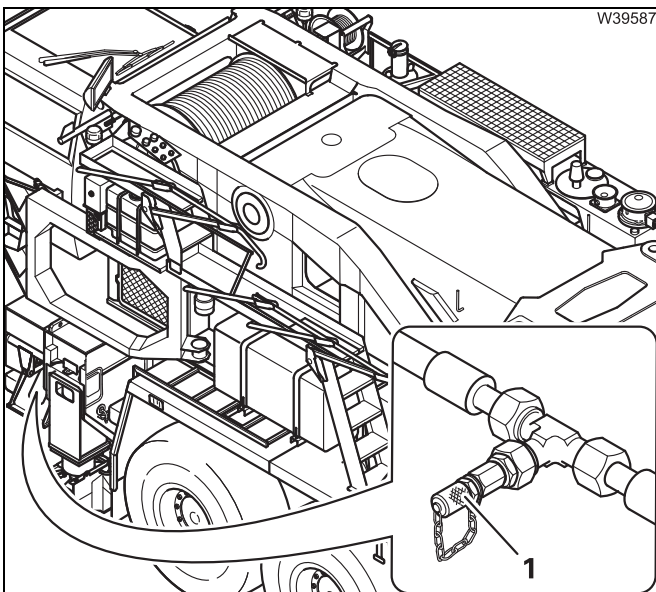

The gauge port (1) is located on the cylinder of the outrigger.

- Clean the gauge port before connecting the hose.

Protecting the hose from dirt

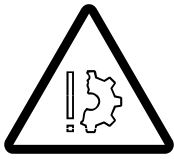

Danger of contamination of the oil sample!

If the hose with the connecting piece is dirty, the dirt can contaminate the oil sample in the sample container during the sampling process. The laboratory analysis would then be incorrect.

For flushing, always allow 2 litres (0.5 gal) of oil to flow through the hose into a receptacle before filling the sample container.

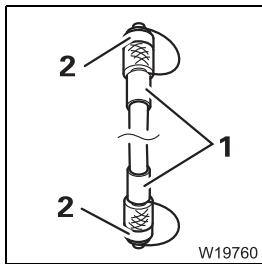

When storing the hose

- Close the hose ends (1) with the caps (2).

Connecting the hose



Danger due to escaping hydraulic oil!

When you screw the connecting piece on to the gauge port, the gauge port opens and oil flows out of the hose. Put the hose end into a receptacle before screwing on the connecting piece.

Always let consumables drain into suitable receptacles. Wipe up any consumables that escape.

Store/dispose of consumables and any soaked equipment properly.

Ask about the applicable regulations.

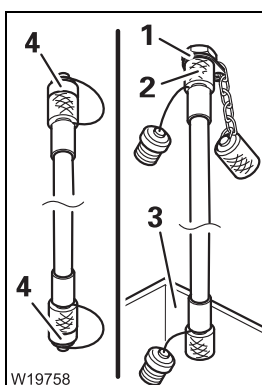

- Only use a hose with a connecting piece.
- Remove the caps (4).
- Put the hose end into the receptacle (3).
- Remove the cap from the gauge port (1) and screw the connecting piece (2) on to the gauge port – the gauge port opens.



Taking oil samples

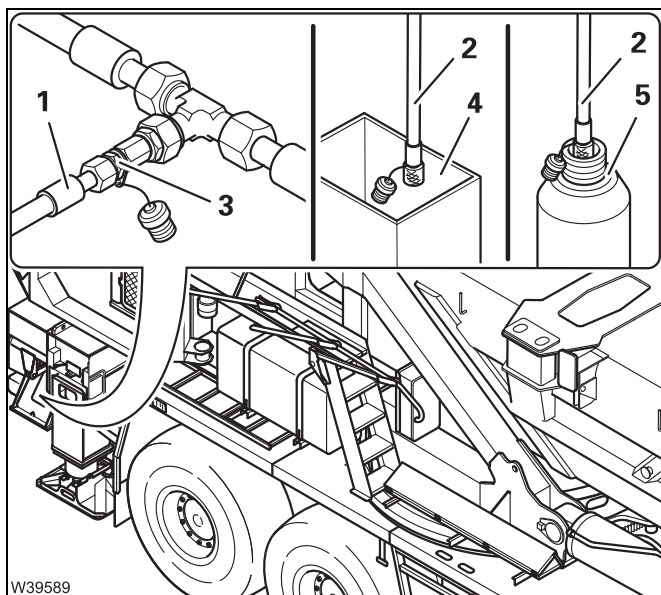

The hose end (1) is connected to the gauge port (3).

The hose end (2) is in receptacle (4).

- Start the engine.
- Allow 2 litres (0.5 gal) of oil to flow into the receptacle.
- Switch the engine off and put the hose end (2) into the sample container (5).
- Start the engine.
- Allow 0.3 litres (0.08 gal) of oil to flow into the sample container.
- Switch the engine off.
- Put the hose end back into the receptacle.
- Seal the sample container.

Disconnecting the hose

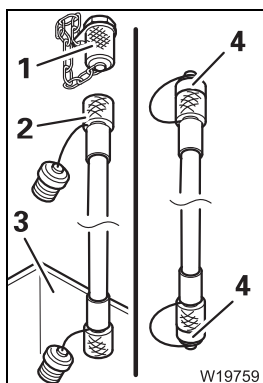

- Disconnect the hose (2) – the gauge port (1) closes.
- Close the gauge port with the cap.
- Allow the oil to flow out of the hose into the receptacle (3).
- Close the hose ends with the caps (4).
- Remove the receptacle and properly dispose of the oil.

Dispatch the oil sample to the laboratory

Manitowoc Crane Care gives you the opportunity to have the oil sample analysed at our contracted laboratory. A delivery note and a protective mailing bag are available along with the sample containers (GROVE part no. 03141012). You will get the laboratory analysis via the Internet in a short time.

- Label the sample container prior to dispatch with
 - the truck crane serial number,
 - date of sample,
 - the number of operating hours since the last oil change and
 - the sampling location (e.g. gauge port on a control block).
- Have the following properties of the oil sample determined by the laboratory
 - the viscosity,
 - the viscosity index,
 - the contamination,
 - the water content.

Determining the quality of the oil

- Compare the laboratory analysis with the **limit values** and carry out the specified measures if necessary.

Viscosity limit values

- Viscosity ISO-VG 32 as per DIN 51524 Part 2.
- Viscosity index $V_i \geq 150$.

If one of these limit values has been reached/fallen short of:

- Carry out an oil change;  P. 7 - 97.

Contamination limit value

- Contamination according to NAS 1638 Class 7 or ISO 4406:1999 Code 18/16/13 (cleanliness class).

If this limit value has been reached/exceeded:

- Replace the filters of the hydraulic system;  P. 7 - 101.
- Have the hydraulic oil cleaned with a mobile filter unit until the required cleanliness class is achieved.

Water content limit value

- Water content ≤ 100 ppm.

If this limit value has been reached/exceeded:

- Have the hydraulic oil cleaned with a mobile water separator until the water content is clearly below the limit value.

Blank page

7.14.7 Changing the hydraulic oil

The oil only needs to be changed if the laboratory analysis indicates the need for it; *Determining the quality of the oil*, P. 7 - 95.

Oil, spare parts,
tools

Hydraulic oil in litres (gal)	Designation to DIN 51502	Specifications Classification	GROVE part no.
200 (53)	HVLP	DIN 51524-3 Viscosity: ISO-VG 32	04162158 Castrol Hyspin AWH-M 32

Designation	Quantity	GROVE part no.
Cover gasket 140 / 90 x 3	1	02313899

- Connecting piece and hose (toolbox).
- One or more receptacles, approx. 200 l (53 gal); P. 2 - 4.

Prerequisites

- The outriggers are retracted; *Operating manual*.
- The engine must not be running and must be secured against unauthorised use; P. 2 - 3.

Closing the valves



Risk of damage to the hydraulic pumps!

Be sure to secure the engine against unauthorised use.

If the engine is started while the valves in the suction line are closed, the hydraulic pumps will be damaged!

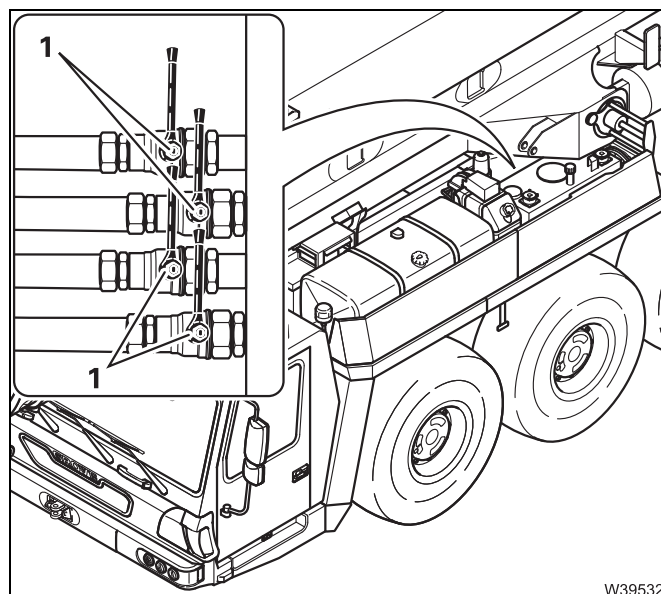

- Close the valves – lever (1) at right angles to the line.



Handling the valves

The valves can only be opened and closed using the connecting piece and hose. The connecting piece is available in the toolbox.



Risk of environmental damage due to leaking consumables!

Use the supplied connecting piece and hose and a receptacle with sufficient capacity to drain the hydraulic oil.



Danger due to escaping hydraulic oil!

When the connecting piece is screwed on to the valve, the valve opens and the hydraulic oil immediately flows out of the connecting piece. Holding it by the connecting piece, place the hose into a suitable receptacle before screwing on the connecting piece.

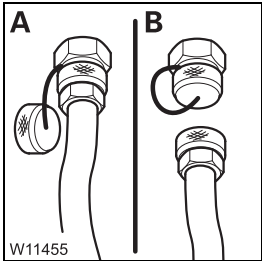

- Fit the hose on to the connecting piece and put the other end of the hose into a receptacle.
- **A** – Remove the cap and screw the connecting piece and hose on to the valve – the valve will open.
- Drain the oil.
- **B** – Remove the connecting piece and hose – the valve will close.
- Screw the cap on to the valve.

Draining oil



Risk of environmental damage due to leaking consumables!

Use the supplied connecting piece and hose and a receptacle with sufficient capacity to drain the hydraulic oil.

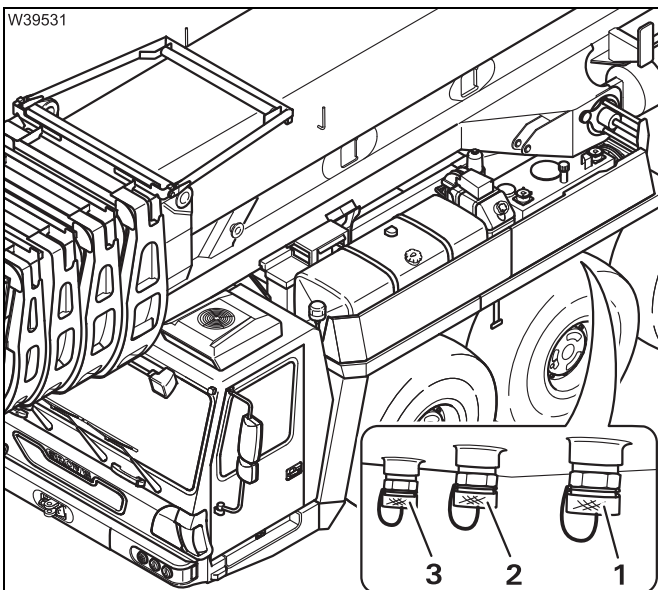

- Place a receptacle underneath the valves.
- One after the other, screw the connecting piece and hose onto the valves (1), (2) and (3);
▣▣▣▣ Handling the valves, P. 7 - 98.
- Change the filters; ▣▣▣▣ P. 7 - 101.

Topping up the oil



Risk of damage to the hydraulic system!

Cleanliness is of the utmost importance when handling hydraulic oil. Even fresh hydraulic oil must be filtered before it is added to the tank.

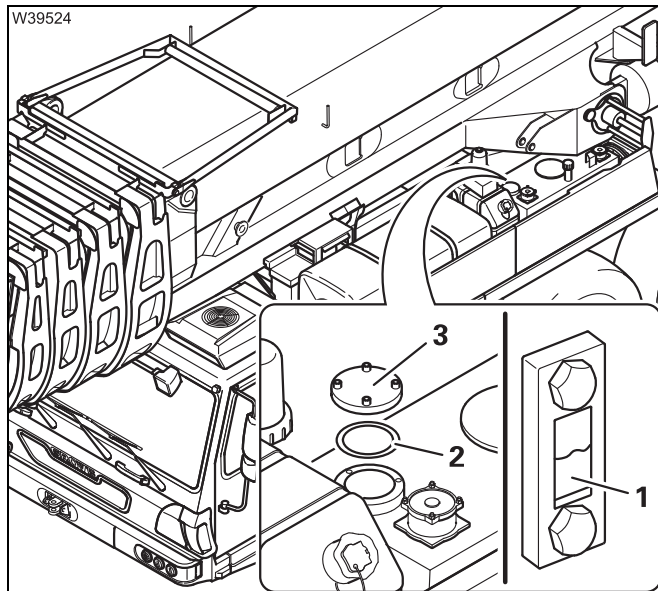

- Remove the cap (3).
- Add new oil through a filter until the level reaches the centre of the sight glass (1).
- Replace the gasket (2) if necessary and fasten the cap (3).

Establishing an operational status

After having changed the oil filters and topping up the oil, you must re-establish the operating conditions.



Risk of damage to the hydraulic pumps!

Open the valves prior to starting the engine. This prevents damage to the hydraulic pumps.

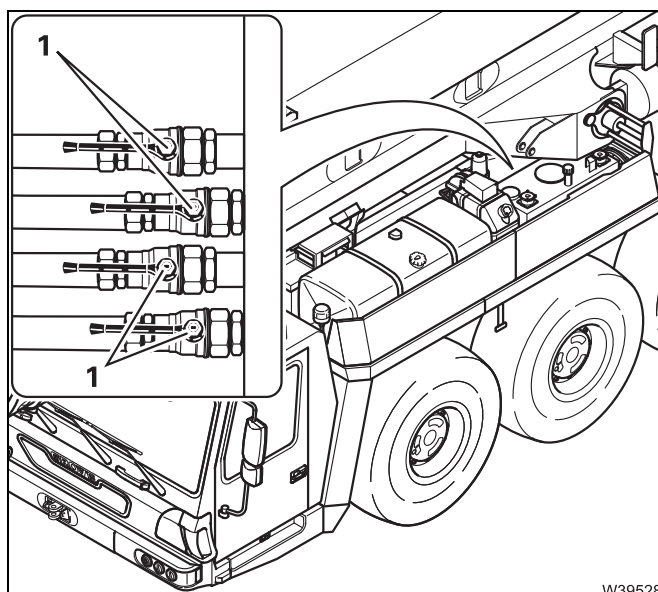

Opening the valves

- Open the valves – lever (1) parallel with the line.



- Start the engine.
- Carry out all hydraulic functions several times to remove any air in the system.
- Test drive the truck crane, turning the steering wheel several times to its fullest extent.
- Check the oil level through the sight glass on the hydraulic oil tank. Top up oil if necessary;  *Check the oil level, P. 7 - 87.*

Bleeding the hydraulic system

If the steering is “loose” during the test drive, you must bleed the steering cylinders of the hydraulic system.

Preparations

- The truck crane is raised on outriggers;  *Operating manual.*
- The parking brake must be applied.



Risk of crushing from turning wheels!

When working between the wheels ensure that the steering wheel cannot be turned by an unauthorised person. The wheels turn when the steering wheel is operated.



Risk of accidents from high oil pressure!

Never undo the hose connections completely. The hydraulic system is under pressure, even when the steering wheel is not turned.

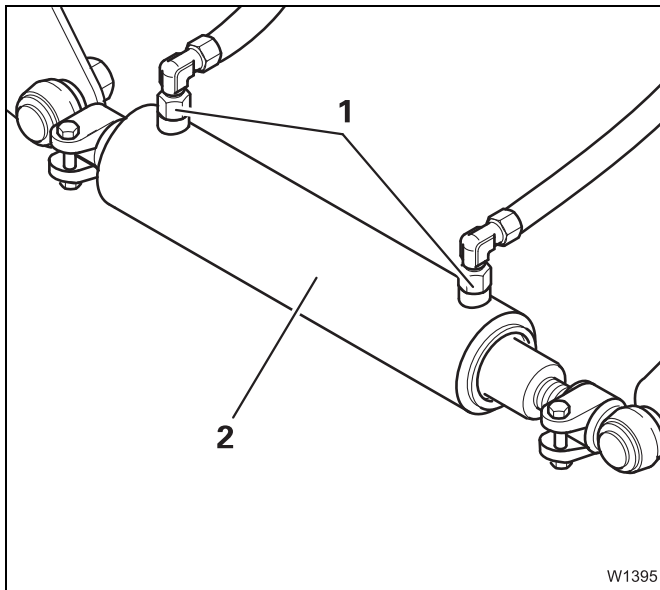

Bleed the steering cylinders individually, one after the other

- Start the engine.
- Bleed each steering cylinder (2) by loosening each of the collar nuts (1) in turn, until the oil coming out no longer contains air bubbles.

If the steering system is still not operating properly

- Notify **Manitowoc Crane Care** or an authorised GROVE dealer or an authorised specialist workshop.

7.14.8

Changing the hydraulic oil filter

The hydraulic oil filters must be replaced when changing the oil.

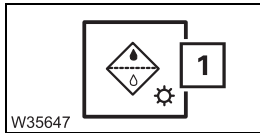

If the warning lamp (1) lights up, change the hydraulic oil filter.

Spare parts and tools

Designation	Quantity	GROVE part no.
Filter (for filters 1 and 2)	2	03329152
Packing set	2	03135778

– Receptacle, approx. 5 l (1.5 gal); P. 2 - 4.

Prerequisites

– The engine must not be running and must be secured against unauthorised use; P. 2 - 3.



Changing filters 1 and 2



Risk of damage to the environment from filter residues!

Store used hydraulic oil filter inserts in suitable receptacles and have them disposed of properly by qualified personnel.

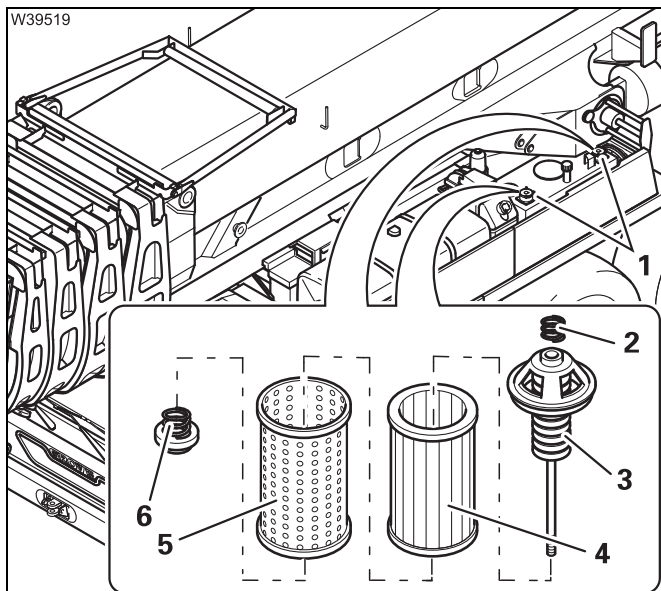

- Release the cap (1) and pull out the filters.
- Place the filters in a receptacle.
- Remove the spring (2).
- Remove the nuts (6).
- Remove the magnetic rod (3) and filter (4) from the filter cage (5).
- Clean the magnetic rod (3) and filter cage (5).
- Insert a new filter (4) into the filter cage (5).
- Replace any damaged parts, if necessary.



Risk of damage to the hydraulic system

Large amounts of metal particles are a sign of damage in the hydraulic system.

Have the hydraulic system checked by **Manitowoc Crane Care** or an authorised GROVE dealer or your repair crew.

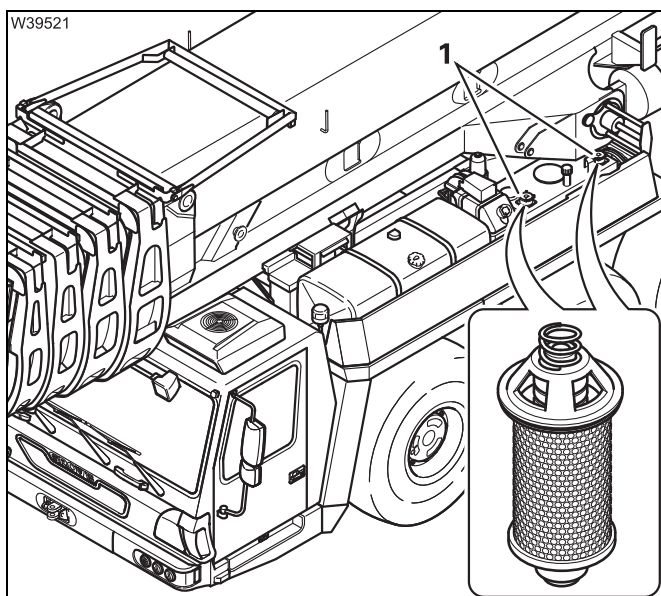

- Assemble the filters and install them.
- Replace the gaskets and fasten the caps (1).
- Start the engine and check for leaks.

7.15 Central lubrication system

The central lubrication system supplies the steering lever on the first, second and third axle lines.

7.15.1 Checking the filling level

W

Grease, spare parts, tools

Lubricating grease	Designation to DIN 51502	Specifications Classification	GROVE part no.
Grease	KP - 1K - 50	DIN 51825	03233369

– Filling pump from the tool set.

Prerequisites – The parking brake must be applied.

Checking the filling level

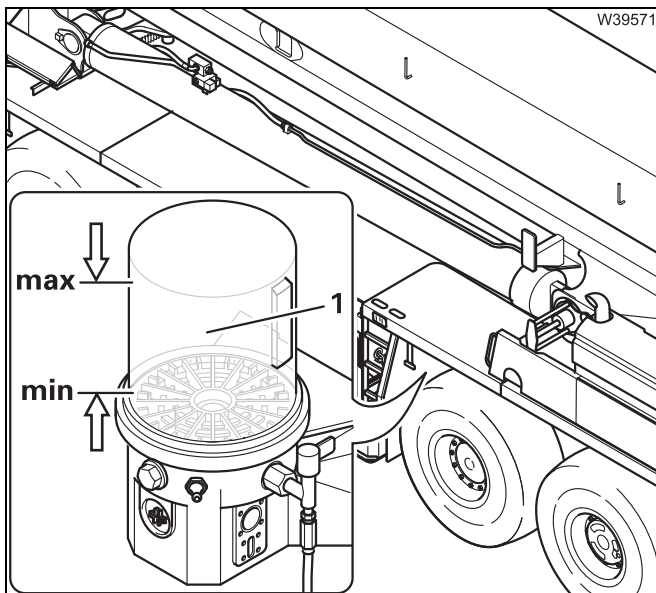

- Check the level in the grease container (1). The filling level must be near the **max.** marking. If it is below the **min.** marking, the level is too low.

If the level is too low

- Add more grease; ► P. 7 - 104.



Topping up



Risk of damage to the central lubrication system!

Cleanliness is of the utmost importance when handling grease and filling pumps.

Do not remove the caps from the opening and filling pump until immediately before refilling the grease. This prevents dirt particles from getting into the grease and damaging the central lubrication system.

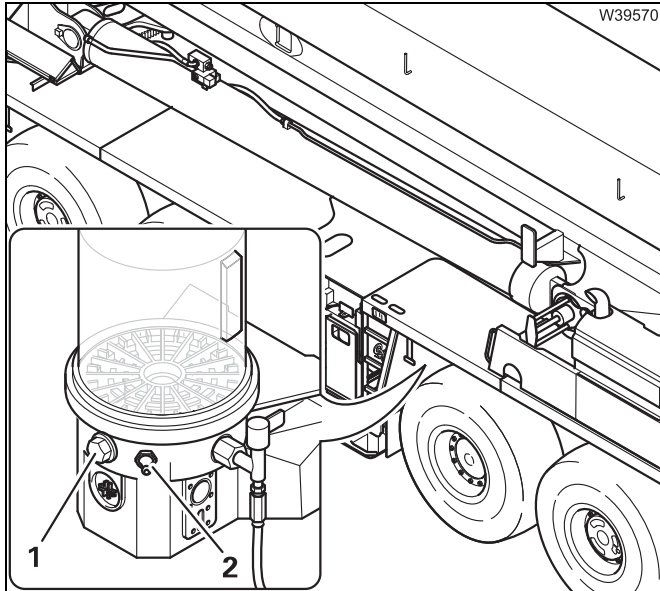

Fill the grease container as follows:

- 1 Filling pump tool set:
You must install the connector from the toolbox.
- 2 Filling pumps for lubrication nipples

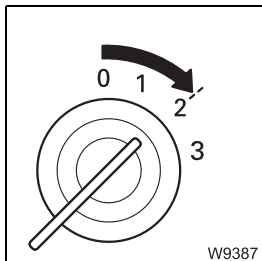

- Switch on the ignition.

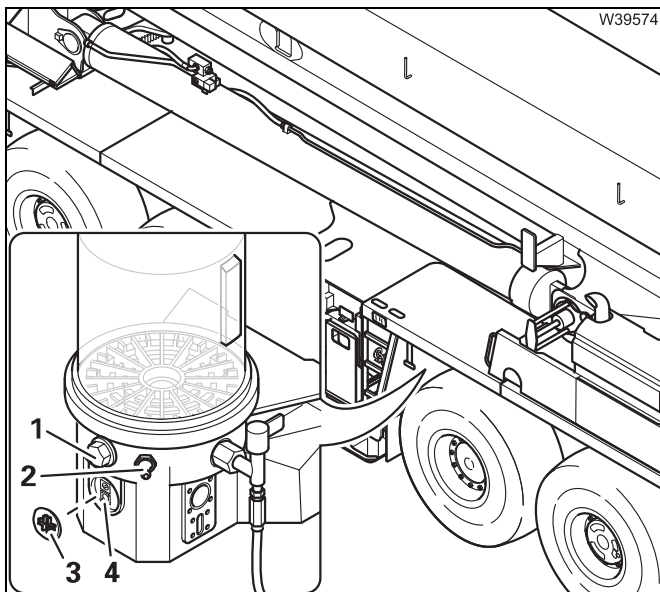

- Remove the cap (3).
- Attach the filling pump to connection (1) or (2).
- Press the button (4) once for approx. 2 seconds.

Intermediate lubrication will be triggered.

- Fill the grease container up to the **Max.** marking.
- Remove the filling pump, wipe away any excess grease and close the holes.

7.15.2

Bleeding the central lubrication system

If the grease container is empty or contains bubbles, you must bleed the central lubrication system.

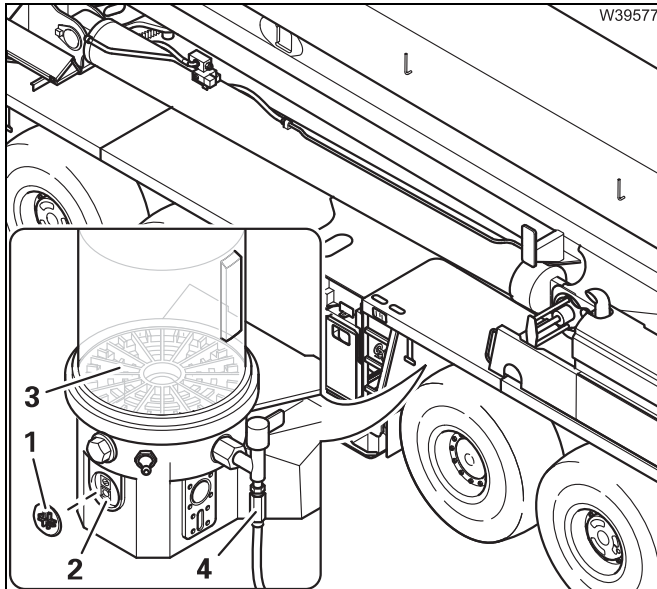

The grease container (3) must be full.

- Undo the connection (4).
- Switch on the ignition.
- Remove the cap (1) and press button (2) once for approx. 2 seconds. Repeat the procedure until the grease flowing from the connection no longer contains any bubbles.
- Attach the connection and the cap.
- Remove any grease that has escaped.

7.15.3

Triggering intermediate lubrication

Intermediate lubrication should be triggered,

- after high pressure cleaning,
- to check the lubrication system at all lubricating points.

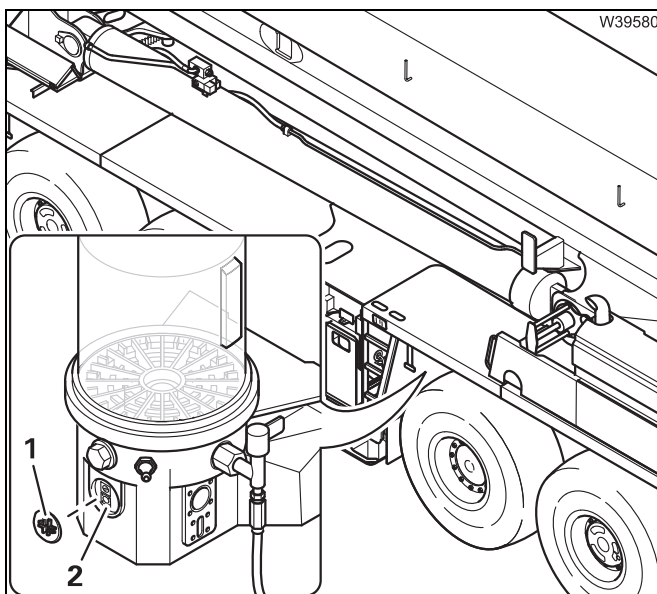

- Switch on the ignition.
- Remove the cap (1) and press button (2) once for approx. 2 seconds.

An intermediate lubrication cycle will be triggered which lasts approximately 3 minutes. Check whether grease is applied to all lubricating points (steering arms on the 1st, 2nd and 3rd axle lines).

- Switch off the ignition and remove any excess grease.
- Fasten the cap.

Blank page

7.16 Electrical system

7.16.1 Checking the lighting and indicators

D



Risk of accidents if the safety devices are faulty!

Have faulty lights and indicators repaired by **Manitowoc Crane Care** or an authorised GROVE dealer or an authorised specialist workshop.

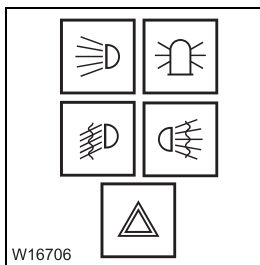

- Check the following functions every day before operating or driving the truck crane, and have faulty parts repaired:

- Parking light/headlight, marker lights, rotating beacons, fog tail light, fog light, outrigger lights,
- Hazard warning system,
- Brake lights,
- Reversing lights,
- Warning buzzer,
- Reversing lamp (additional equipment).

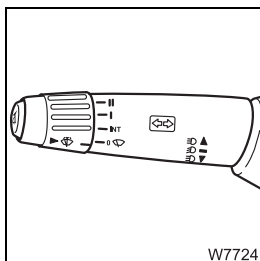

- Full-beam headlight,
- Turn signal indicators,
- Horn,
- Windscreen wipers,
- Windscreen washing system.

7.16.2

Checking the batteries

M 1



Risk of poisoning from batteries containing lead!

Battery poles, terminals and parts inside the battery contain lead. Residue containing lead can stick to your hands and may not be allowed to enter your body – e.g. by touching food.

Wash your hands after working on batteries.



Risk of explosion from escaping hydrogen!

Do not place tools on the battery and keep naked lights away from it.



Risk of explosion from static charge!

Use only antistatic cloths to clean the batteries.

This prevents the build-up of static charges which could cause hydrogen mixtures to explode.



Risk of burns from battery acids!

Battery acid is highly caustic. Wear safety glasses and protective gloves. Do not tilt the battery. Rinse off or wash out any acid spray on the skin or clothing using soap suds.



Risk of damage to the crane's electrical system!

Always switch off the battery master switches before commencing work on the truck crane's electrical system.

This prevents short circuits and resulting damage to the electrical system.

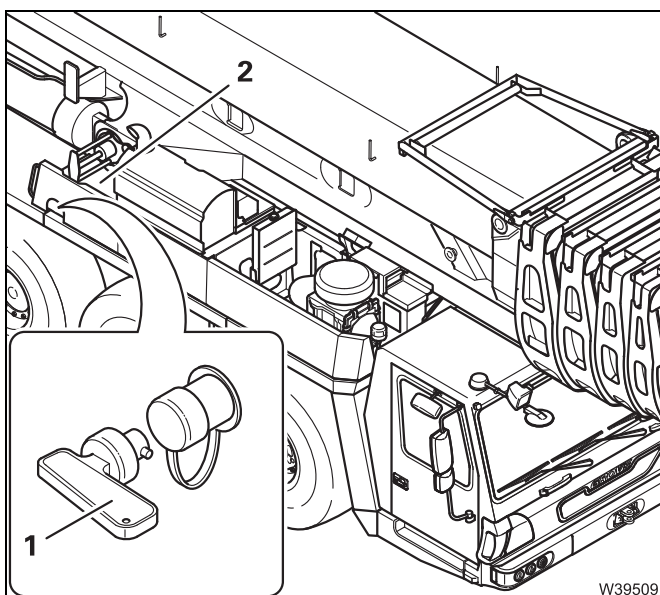

Before checking

- Switch the battery master switch (1) off and remove the selector handle.
- Open the cover (2) on the battery box.

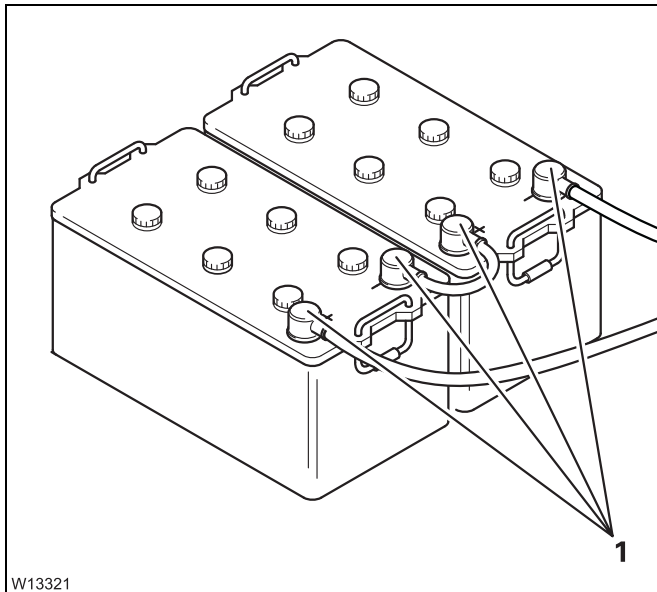

Checking the connecting terminals

- Keep the batteries clean and dry.
- Release any dirty connecting terminals (1) and clean them.
- Fasten any loose connecting terminals.
- Grease the connecting terminals and poles lightly with a special battery terminal grease.

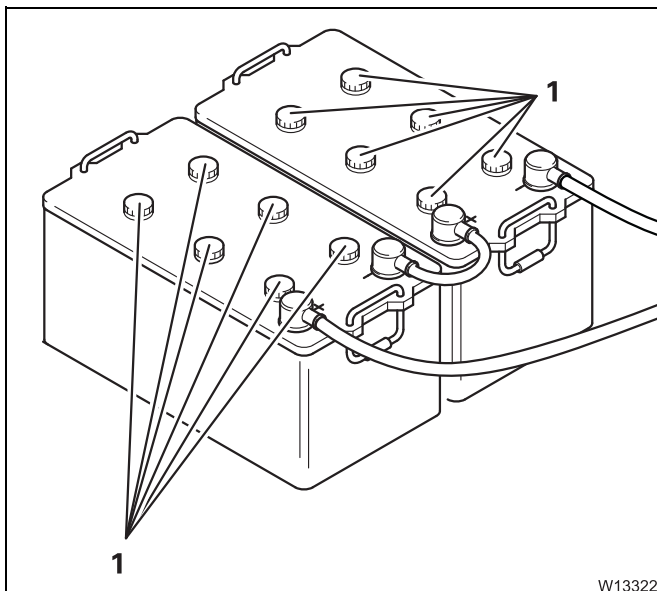

Checking the acid level

Batteries without covers (1) are maintenance-free.

- Remove all covers (1).
The acid level must be above the plates.

If the acid level is too low

- Top it up using only distilled water until the plates are covered.
- Tightly screw on all covers (1).

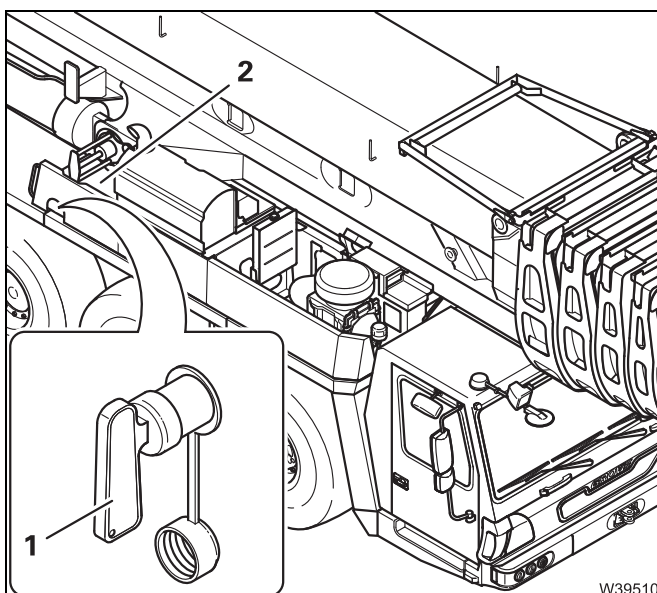

After checking

- Close the cover (2) on the battery box.
- Attach the selector handle and switch on the battery master switch (1).
- Check the timers on the tachograph and the auxiliary heater; *Operating manual*.
- Enter the code for the radio; *Separate operating manual*.

7.16.3

Checking the charge level of the batteries

M 3

Spare parts and tools

- Battery testing device;  *Separate operating manual*, or
- Acid siphon.

Charge level table

The measurement of the acid concentration with the acid siphon will give you an indication of the charge level of the batteries. The acid siphon can have a scale in g/cm³, for example. Observe the special scale on your acid siphon.

Acid concentration (g/cm ³)	Charge level
1.28	good
1.20	half-charged; recharge
1.12	flat; recharge immediately



Risk of poisoning from batteries containing lead!

Battery poles, terminals and parts inside the battery contain lead. Residue containing lead can stick to your hands and may not be allowed to enter your body – e.g. by touching food.

Wash your hands after working on batteries.



Risk of explosion from escaping hydrogen!

Do not place tools on the battery and keep naked lights away from it.



Risk of explosion from static charge!

Use only antistatic cloths to clean the batteries.

This prevents the build-up of static charges which could cause hydrogen mixtures to explode.



Risk of burns from battery acids!

Battery acid is highly caustic. Wear safety glasses and protective gloves. Do not tilt the battery. Rinse off or wash out any acid spray on the skin or clothing using soap suds.



Risk of damage to the crane's electrical system!

Always switch off the battery master switches before commencing work on the truck crane's electrical system.

This prevents short circuits and resulting damage to the electrical system.

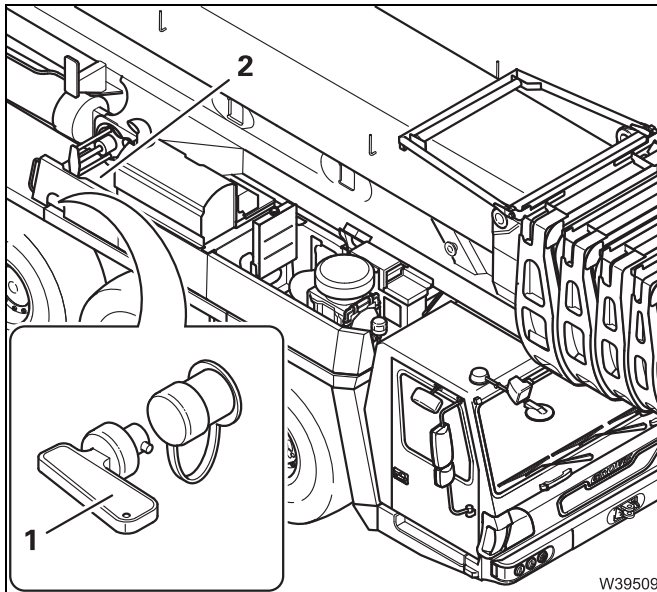

Before checking

- Switch the battery master switch (1) off and remove the selector handle.
- Open the cover (2) on the battery box.

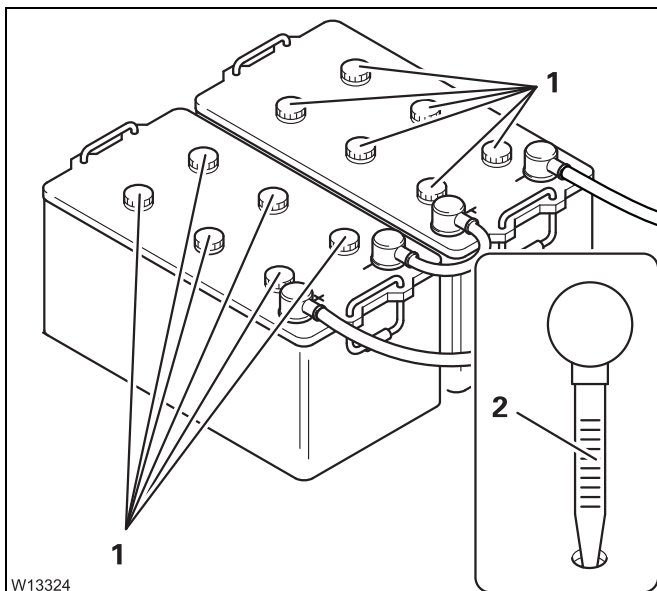



Checking the acid concentration

Batteries without covers (1) are maintenance-free.

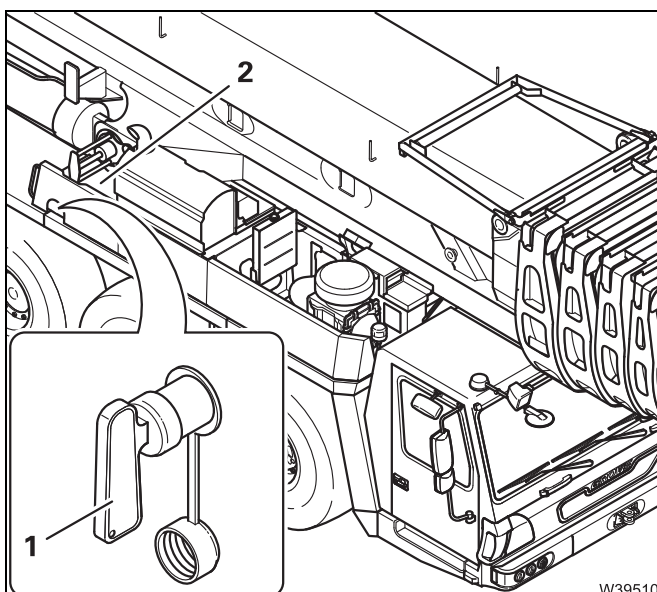
- Remove all covers (1).
- Read off the cell value on the acid siphon (2) and compare the value with that in the table;  *Charge level table, P. 7 - 110.*
- Check all cells in the same way.
- Tightly screw on all covers (1).



After checking

- Close the cover (2) on the battery box.
- Attach the selector handle and switch on the battery master switch (1).
- Check the timers on the tachograph and the auxiliary heater;  *Operating manual.*
- Enter the code for the radio;  *Separate operating manual.*

7.16.4

Charging the batteries using the battery charger

M 3

Prerequisites

- The engine must not be running and must be secured against unauthorised use;  P. 2 - 3.
- An external 230 V mains power supply must be available at the location.
- The battery charger (GROVE part no. 03320239; additional equipment) must be available.
- The location must be well ventilated and protected against moisture. The battery charger may not be used at locations where there is risk of a gas or dust explosion.

Battery charger

- Familiarise yourself with the correct operation of the battery charger;  *Separate operating manual.*

Connecting

- Take the battery charger out of its storage compartment in the driver's cab.

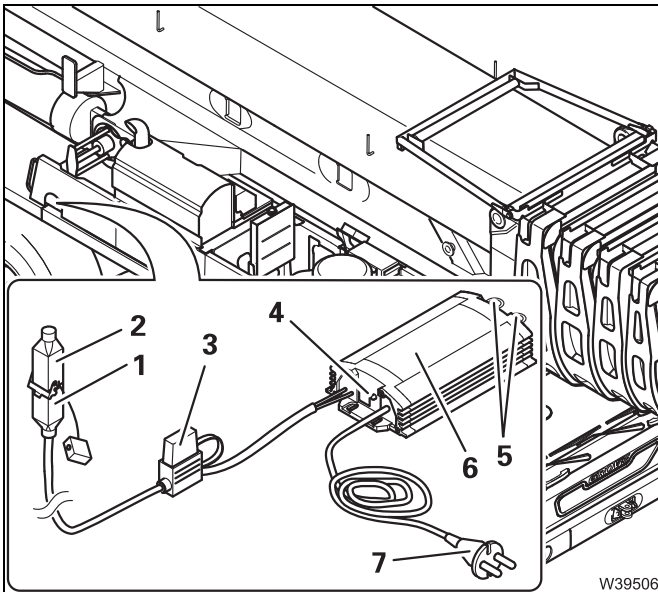

- Insert the plug (1) into the socket (2) on the battery box.
- Place the battery charger (6) in a protected place where you can see the indicator lamp (4).
The battery charger can be suspended from the ring eyes (5).
- Insert the plug (7) into the socket on the mains supply 230 V at the location.
The indicator lamp (4) flashes – the charging process starts.
- If the indicator lamp (4) does not flash, check the fuse (3).

Charging

- Check the charging process at the indicator lamp (4).

Indicator lamp flashing: The batteries are being charged.

Indicator lamp lit continuously: The batteries are fully charged.

After completion of charging

- Remove the plug (7) from the 230 V mains supply.
- Remove the plug (1) from the battery box.
- Return the battery charger to the storage compartment in the driver's cab.

7.17 Air-conditioning system

7.17.1 Checking the air-conditioning system

M 1

The air-conditioning control panel is located on the ceiling in the driver's cab. The compact air-conditioning system is located on the roof of the driver's cab.

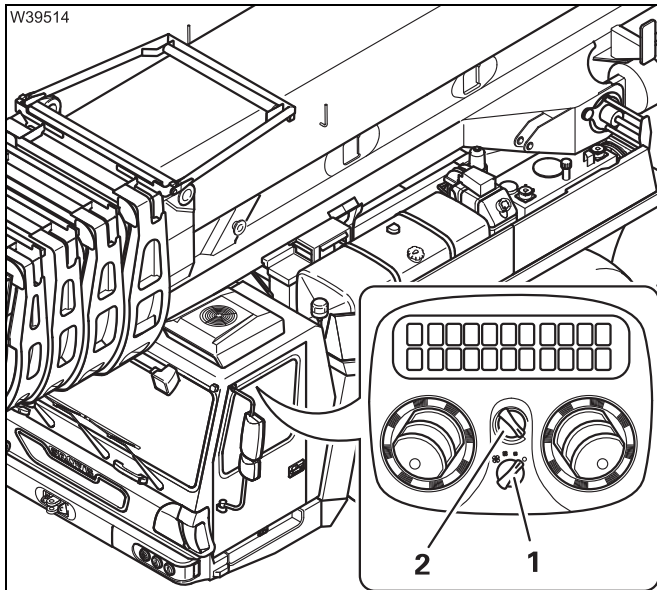

- Switch on the air conditioning system with at the switches (1) and (2);  *Operating manual*.
- Check that cooling takes place. If it does not, the air-conditioning system is defective.
- Switch off the air conditioning system at the switches (1) and (2).

If the air-conditioning system is defective

- Do not start it up again to avoid further damage.
- Have the air-conditioning system repaired as soon as possible by **Manitowoc Crane Care** or an authorised GROVE dealer or an authorised specialist workshop.

7.17.2 Checking hoses

M 6



Risk of burns due to escaping refrigerant!

Wear suitable safety glasses and gloves when checking the hoses and connections.

This will prevent injury from suddenly escaping refrigerant. Seek medical attention if the skin or eyes come into contact with the refrigerant.

- Check all refrigerant hoses for damage and areas of wear.

Have damaged hoses replaced only by **Manitowoc Crane Care** or an authorised GROVE dealer or an authorised specialist workshop.

7.17.3

Cleaning the condenser fins

M 12



Risk of damage to the condenser!

Do not use a high pressure cleaner or steam jet cleaner. The hard jet can damage the fins and the fan. Use only compressed air for cleaning.

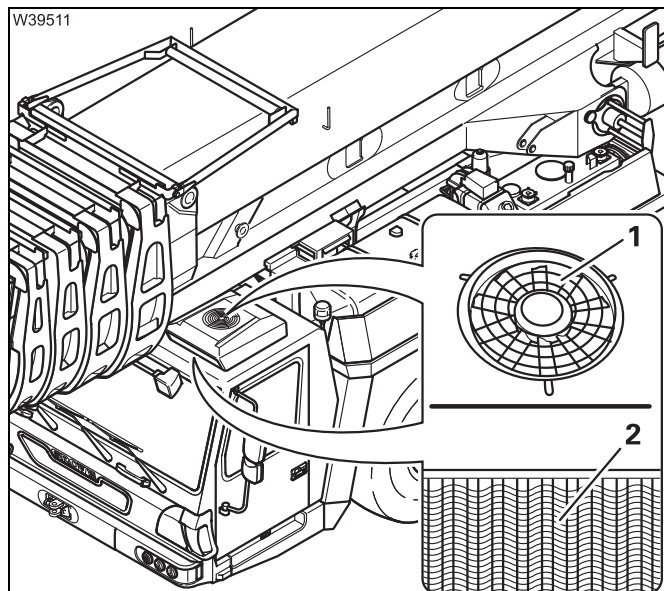

- Switch the air-conditioning system off;  *Operating manual*.
- Clean the fins of the condenser (2) and the fan (1) with compressed air.

7.17.4

Checking the entire air-conditioning system

M 12



This inspection may only be performed by **Manitowoc Crane Care** or an authorised GROVE dealer or an authorised specialist workshop!



Risk of burns due to escaping refrigerant!

Wear suitable safety glasses and gloves when checking the hoses and connections.

This will prevent injury from suddenly escaping refrigerant. Seek medical attention if the skin or eyes come into contact with the refrigerant.

- Have the entire air-conditioning system checked for leaks and proper functioning.
The inspection of the air-conditioning system particularly includes the inspection of
 - The refrigerant collector, in accordance with the pressure container regulations (test group II) and
 - The refrigerant compressor.
- Only allow the system to be topped up with suitable refrigerant.

Refrigerant

Fill quantity in kg (lbs)	Designation	CAS no. EC no.
1.25 (2.75)	Tetrafluoroethane (R134a)	811-97-2 212-377-0

Filler connections

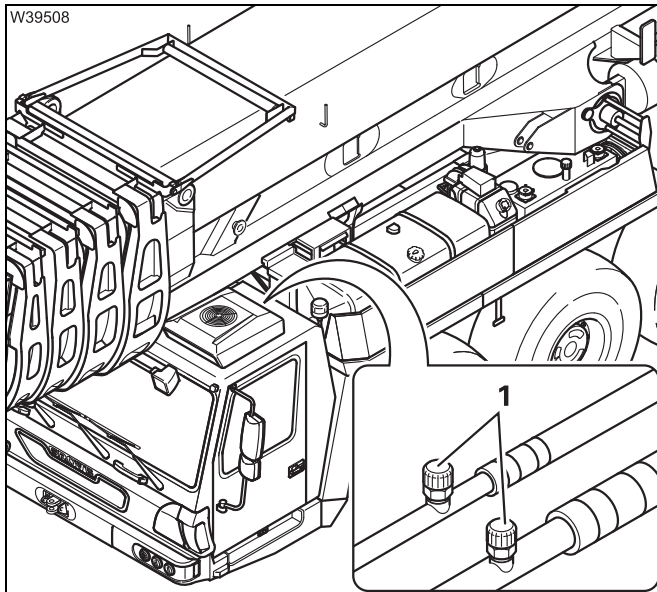

The filler connections (1) for the refrigerant are located on the roof of the driver's cab.

7.17.5

Changing the pollen filter

M 12

Reducing the interval

- Under difficult operating conditions – at extremely sandy or dusty locations – you must change the pollen filter earlier than usual.

Spare parts and tools

Designation	Quantity	GROVE part no.
Pollen filter for roof air-conditioning system (184-192-0016 24V Aurora; cpl.)	1	03268376 cpl.
Pollen filter for heating system	1	02212145

Prerequisites

- The engine must not be running and must be secured against unauthorised use; ►► P. 2 - 3.

Changing

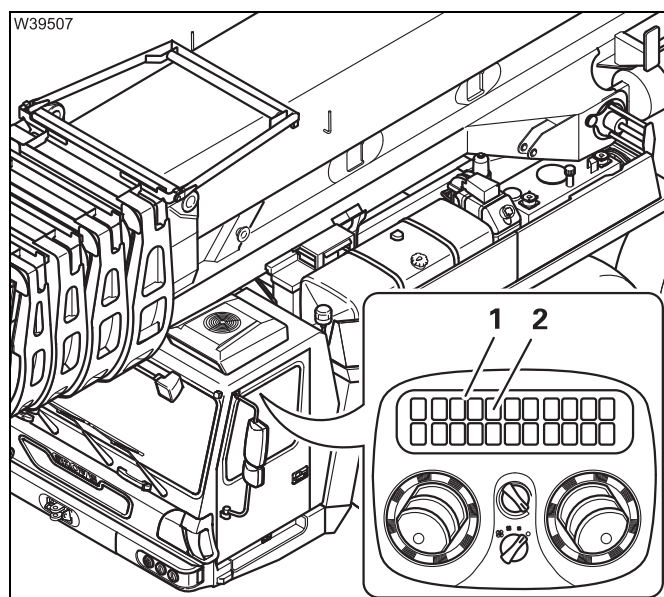

Air-conditioning system

- Remove the frame (1).
- Remove the filter (2) from the housing and clean the housing with a cloth.
- Insert a new filter.
- Fasten the frame (1).

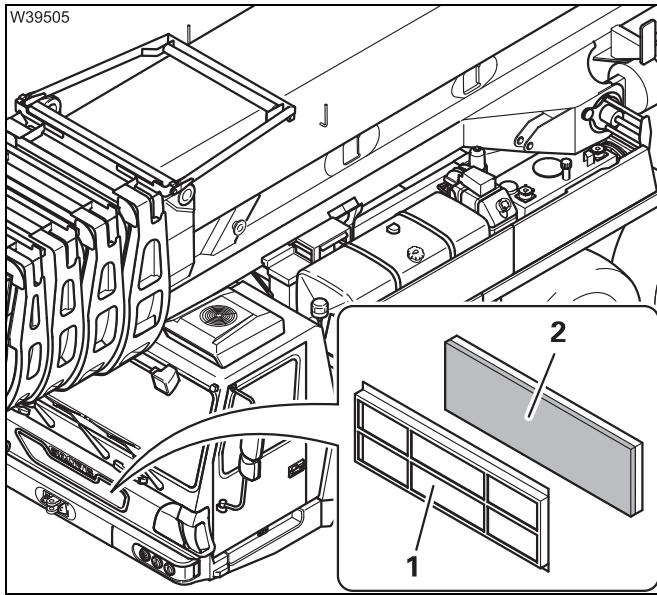

Heating system

- Remove the frame (1).
- Remove the filter (2) from the housing and clean the housing with a cloth.
- Insert a new filter.
- Fasten the frame (1).

Blank page

7.18 Other maintenance work

7.18.1 Checking the windscreen washing system

W

Water, spare parts, tool

Designation	Quantity	GROVE part no.
Wiper blades	3	02311858

- Water; add commercially available detergent and antifreeze to it.
- A can for mixing and filling.

Topping up

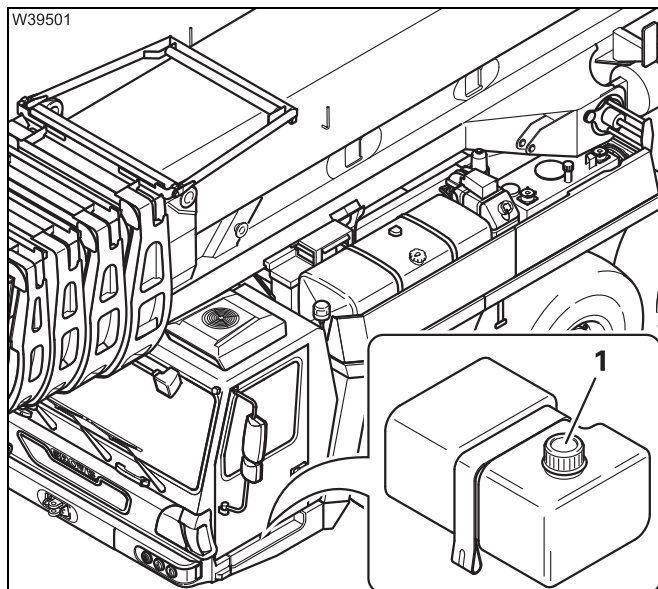

- Open the cap (1) on the filler neck.
- Top up the windscreen washing fluid through the filler neck.
- Close the filler neck with the cap.

Wiping

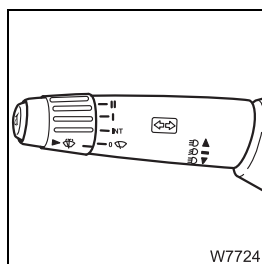

- Press the multipurpose switch of the windscreen wiper/washing system;  *Operating manual*.

- Check all the wiping stages (slow, fast, intermittent).

If the windscreen does not wipe clean

- Change the wiper blades.

7.18.2

Lubricating the outrigger beams

M 1

- Also adhere to the  *Run-in regulations*, P. 4 - 1.

Grease, spare parts, tools

Lubricating grease	Designation to DIN 51502	Specifications Classification	GROVE part no.
Grease	KP - 1K - 50	DIN 51825	03233369
Spray	Spray on Berulub; 0.5 litres (spray-on spray)		01929824

- Brush or roller.



Risk of crushing by extending outrigger beams!

Ensure that there is sufficient room around the crane. Warn any persons nearby before extending the outrigger beams. Observe the safety instructions in the operating manual.

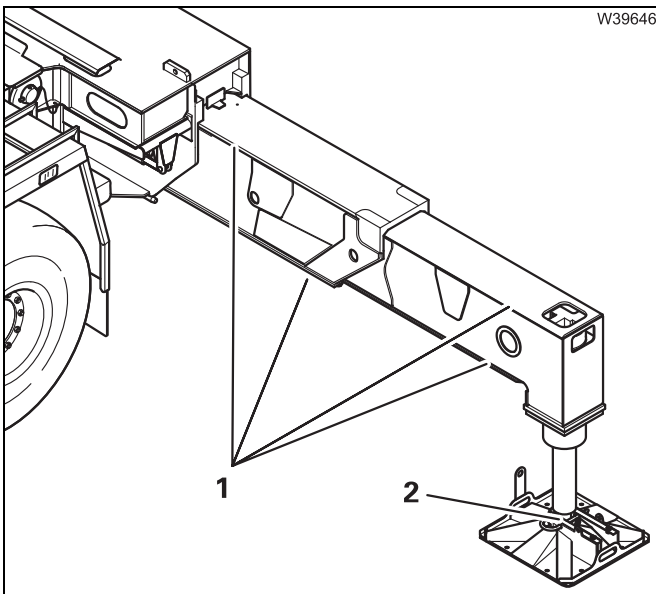

- Fully extend all outrigger beams;  *Operating manual*.
- Apply the grease to both sides of the slide faces (1) on all the outrigger beams.
- Extend and retract the outrigger beams several times.
- Remove any excess grease.
- Clean the uncovered end (2) of the outrigger cylinder and bearing surfaces on the outrigger pad by removing old grease, dirt particles and rust.
- Spray the uncovered end (2), making sure the grease coating is evenly distributed.

After every high-pressure cleaning operation on the truck crane

- Lubricate the outrigger beams.

7.18.3

Checking the functioning of the auxiliary heater

M 1

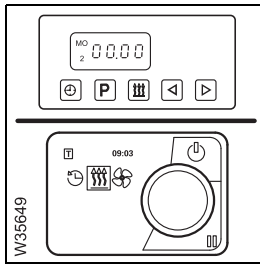

Depending on the equipment, your truck crane is equipped with two auxiliary heaters (driver's cab and battery box).

Even during the warm summer months, run the auxiliary heater for 20 to 30 minutes; *Operating manual*.

- Check that the system is working properly. Also perform a functional check of the controls.
- If the heating system is not working correctly, report it to **Manitowoc Crane Care** or an authorised GROVE dealer or an authorised specialist workshop.

7.18.4

Lubricating the cab door

M 12

Grease, tools

Lubricating grease	Designation to DIN 51502	Specifications Classification	GROVE part no.
Grease	KP - 1K - 50	DIN 51825	03233369

- Grease gun from the tool set.

Greasing

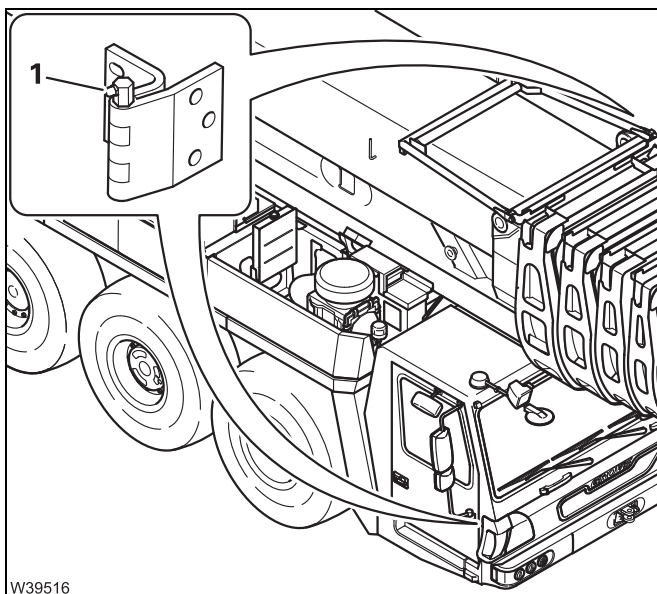

- Open the doors on the driver and passenger side.
- Clean the grease nipples (1) on the door hinges.
- Press grease into the grease nipples.
- Close and open the doors several times – the doors should move easily.
- Remove any grease that has escaped.

- In case the doors are stiff or do not close properly after lubrication, have them adjusted by **Manitowoc Crane Care** or by an authorised GROVE dealer.

7.18.5

Lubricating the connecting and socket pins

M 12

Grease, tools

Lubricating grease	Designation to DIN 51502	Specifications Classification	GROVE part no.
Grease	KP - 1K - 50	DIN 51825	03233369

- Brush.

Checking

Depending on the equipment, there are various connecting and socket pins on the carrier such as:

- Fastenings to hold the hook block on the bumper while driving on the road,
 - Fastenings for ladders on the carrier,
 - Hinged warning panels under the bumper,
 - Fastenings for the outrigger pads and socket pins on the outrigger,
 - Locks on the removable covers,
 - Hinges on the doors and covers of the storage box.
- Check the pins for wear such as rust, deformation, broken clips, chains and pin-type keepers.
 - If the pins are damaged, have them replaced by **Manitowoc Crane Care** or an authorised GROVE dealer or your qualified repair crew.
 - Use only authentic replacement pins.

Greasing

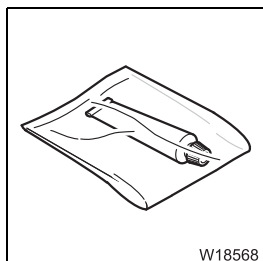

- Clean the pins.
- Lubricate the pins with a brush.

7.18.6

Renewing the corrosion protection

M 12

Protective agent, tools

Protective agent	GROVE part no.
Corrosion protection	03140192

- Spray gun with spray extension.
- Brush.
- Protective clothing, protective goggles.

Prerequisites

- The undercarriage of the truck crane must be thoroughly cleaned.
- The truck crane must be raised on outriggers or parked over an inspection pit.
- The engine must not be running and must be secured against unauthorised use;  P. 2 - 3.

Checking

At the factory, the underside of the carrier was sprayed with corrosion protection for the first time.

The corrosion protection is solvent-free and is water soluble while being sprayed on. A transparent, waxy, protective film is formed after a drying time of one hour.

- Check the condition of the original protective film.
- If required, remove any rust and touch up the paintwork before you spray on a new protective film.

Processing instructions

- Observe the processing instructions for corrosion protection:
 - Working temperature: above 10 °C (50 °F).
 - Removability before drying: with water.
 - Removability before drying: with test petrol.
 - Drying time: 1 hour.



Spraying



Risk of injury to the eyes!

While working with the spray extension you could be hit by the spray jet or spray droplets. Wear protective goggles, protective clothing and gloves.

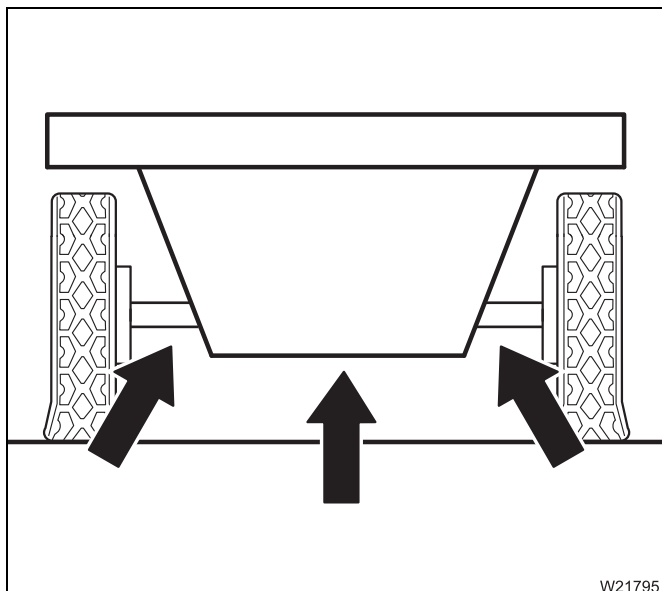

W21795

- Spray the corrosion protection agent on the underside of the carrier using a spray extension.
- Clean surfaces sprayed by accident immediately with water.
- Let the corrosion protection dry for one hour.
- Check that a transparent waxy protective film has covered the entire surface.

7.18.7

Having the fire extinguisher checked

Y 2

Depending on your truck crane's equipment, it can be fitted with fire extinguishers.



The maintenance interval may even be shorter, depending on the respective national regulations and the operating location. Ask the local fire safety officer about the national and local regulations.

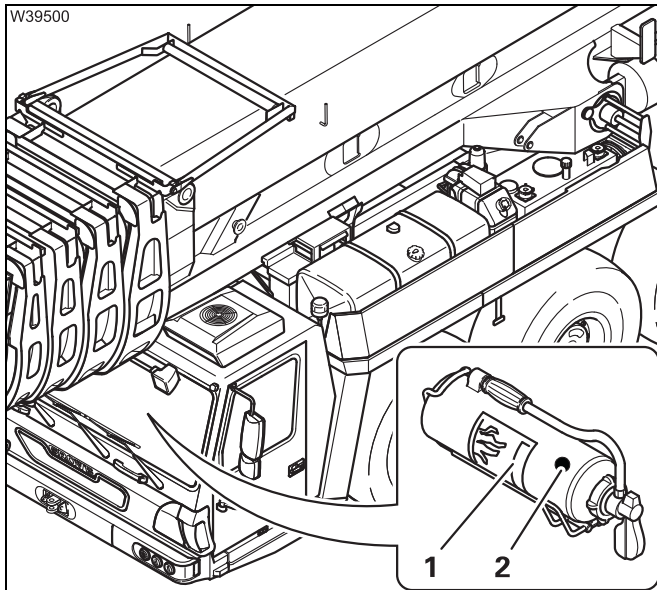

- Observe the operating instructions (1) on the fire extinguisher.
- Have the fire extinguisher serviced by trained personnel in good time before the maintenance interval specified on the label (2) expires.



Danger due to the fire extinguisher not working!

There is no guarantee that the fire extinguisher will still work properly once the maintenance interval on the label has expired.

Blank page

8 Maintenance work on the superstructure

8.1	General instructions	8 - 1
8.1.1	Covers	8 - 1
8.1.2	Overview of maintenance work on the superstructure	8 - 4
8.2	Symbols for maintenance work	8 - 11
8.3	Engine	8 - 13
8.3.1	Check the oil level	8 - 13
8.3.2	Topping up the oil	8 - 15
8.3.3	Checking the air filter	8 - 16
8.3.4	Checking the coolant level	8 - 17
8.3.5	General inspection	8 - 18
8.3.6	Changing the oil and the oil filter	8 - 19
8.3.7	Have the radiator checked/cleaned	8 - 21
8.3.8	Changing the coolant	8 - 25
8.4	Fuel system	8 - 27
8.4.1	Draining off water from fuel filter 1	8 - 28
8.4.2	Replacing fuel filter 1	8 - 29
8.4.3	Replacing fuel filter 2	8 - 31
8.5	Exhaust system with exhaust emission control	8 - 35
8.5.1	Checking the AdBlue tank level	8 - 36
8.5.2	Filling up with AdBlue	8 - 36
8.5.3	Check the exhaust system for external damage	8 - 37
8.5.4	Having the AdBlue system checked	8 - 39
8.5.5	Having the soot particle filter system checked	8 - 40
8.6	Hoists	8 - 43
8.6.1	Checking the oil level	8 - 43
8.6.2	General inspection	8 - 44
8.6.3	Checking the hoist brake	8 - 44
8.6.4	Lubricating the auxiliary hoist	8 - 45
8.6.5	Changing the oil/checking the oil	8 - 46
8.6.6	Having a partial inspection carried out	8 - 48
8.6.7	Having a general inspection carried out	8 - 48
8.7	Slewing gear	8 - 49
8.7.1	Checking the oil level	8 - 49
8.7.2	Checking for leaks	8 - 50
8.7.3	Checking the slewing gear brake	8 - 50
8.7.4	Changing the oil/checking the oil	8 - 52
8.8	Slewing bearing	8 - 55
8.8.1	Checking the screws	8 - 55
8.8.2	Lubricating the gear teeth	8 - 59
8.8.3	General inspection	8 - 61
8.8.4	Measuring tilting play	8 - 62
8.8.5	Lubricating the locking of turntable	8 - 64

8.9	Pump transfer case	8 - 65
8.9.1	General inspection	8 - 65
8.9.2	Check the oil level	8 - 65
8.9.3	Changing the oil	8 - 66
8.10	Hydraulic system	8 - 69
8.10.1	Check the oil level	8 - 69
8.10.2	Checking the hydraulic hoses	8 - 70
8.10.3	Checking the ventilation filter	8 - 70
8.10.4	Checking for leaks	8 - 71
8.10.5	Oil filters 1 and 2 – cleaning the magnetic rod	8 - 72
8.10.6	Changing the ventilation filter	8 - 75
8.10.7	Pressure accumulator – checking the gas pressure	8 - 76
8.10.8	Taking oil samples	8 - 76
8.10.9	Changing the hydraulic oil filter	8 - 78
8.10.10	Changing the hydraulic oil	8 - 82
8.11	Main boom	8 - 85
8.11.1	Grease the piston rod of the derricking cylinder	8 - 85
8.11.2	Lubricating the locking pins	8 - 86
8.11.3	Lubricating the telescopic slide faces	8 - 89
8.11.4	Checking the sheaves	8 - 94
8.11.5	Checking the locking system	8 - 95
8.12	Hoist ropes	8 - 97
8.12.1	Checking the winding	8 - 97
8.12.2	Checking the hoist ropes	8 - 98
8.12.3	Lubricating the hoist rope	8 - 99
8.12.4	Assessing the condition of the hoist rope	8 - 100
8.12.5	Replacing the hoist rope	8 - 106
8.12.6	Setting the lowering limit switch	8 - 109
8.13	Cable drums and slewing angle sensor	8 - 111
8.13.1	Maintenance of the slip ring assemblies	8 - 111
8.14	Central lubrication system	8 - 113
8.14.1	Checking the filling level	8 - 113
8.15	Hook blocks	8 - 115
8.15.1	Checking the sheaves	8 - 115
8.15.2	Greasing	8 - 115
8.16	Electrical system	8 - 117
8.16.1	Checking the lighting and indicators	8 - 117
8.16.2	Checking the batteries	8 - 118
8.16.3	Checking the charge level of the batteries	8 - 118
8.16.4	Charging the batteries using the battery charger	8 - 119
8.17	Air-conditioning system	8 - 121
8.17.1	Checking the air-conditioning system	8 - 121
8.17.2	Checking hoses	8 - 121
8.17.3	Cleaning the condenser fins	8 - 122
8.17.4	Checking the entire air-conditioning system	8 - 122

8.18	Other maintenance work	8 - 125
8.18.1	Checking the windscreen washing system	8 - 125
8.18.2	Checking the functioning of the auxiliary heater	8 - 126
8.18.3	Lubricating the crane cab door	8 - 127
8.18.4	Lubricating the connecting and socket pins	8 - 128
8.18.5	Renewing the corrosion protection	8 - 129
8.18.6	Having the fire extinguisher checked	8 - 131

8

Maintenance work on the superstructure

8.1

General instructions

8.1.1

Covers

Before maintenance work

Various types of work (e.g. oil change) require that covers be removed.

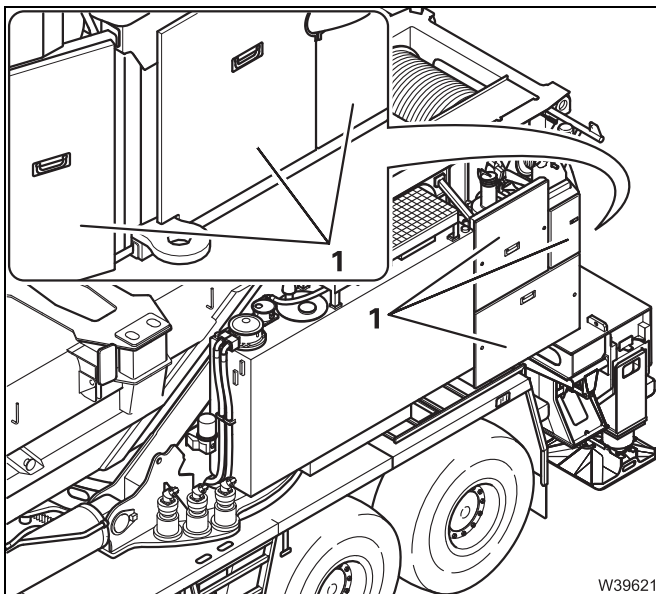

- Slew the crane cab in the *crane operation position*;  *Operating manual*.
- Remove the covers (1).

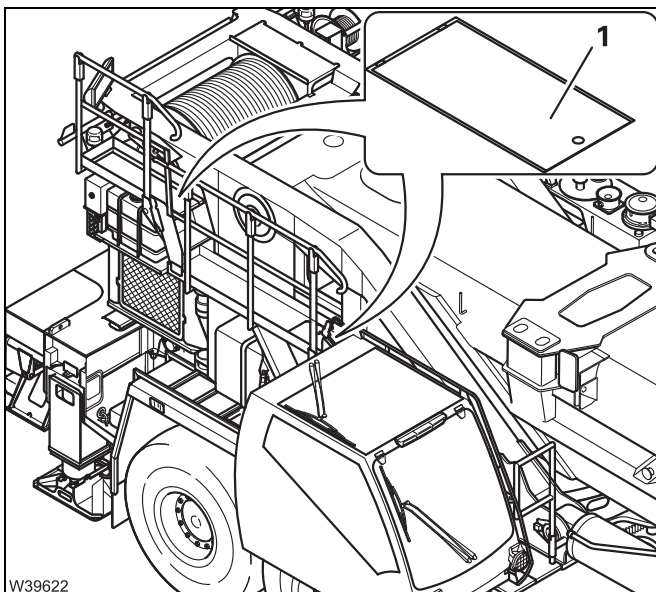

- Fold out the railings, and secure the ladders and platforms (1) in the holders in the *crane operation position*;  *Operating manual*.



After maintenance work

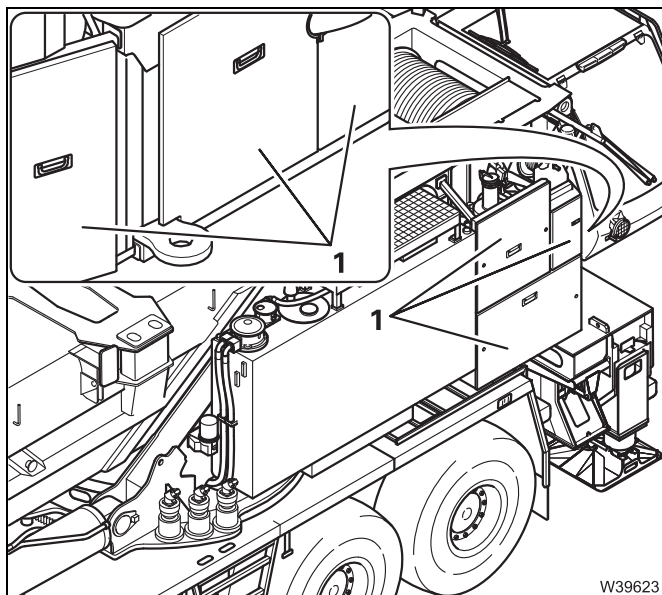

- Slew the crane cab the *driving position*;  *Operating manual*.
- Fasten the covers (1) with the locks.

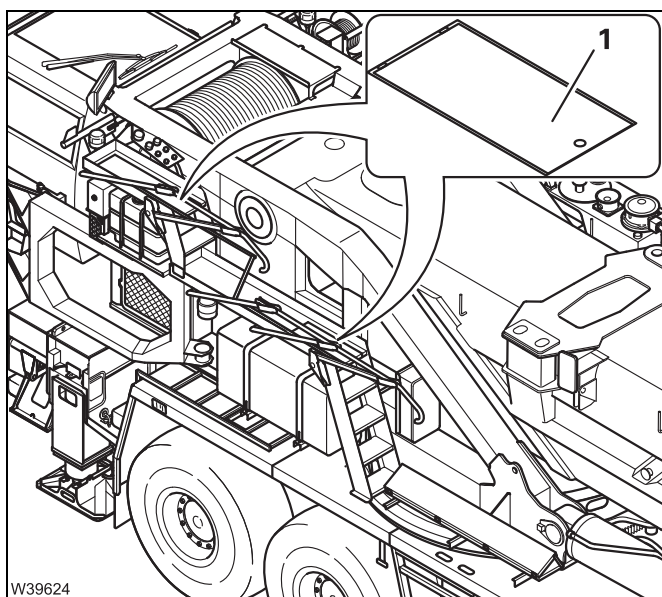

- Fold in the railings, and secure the ladders and platforms (1) in the holders in the *driving position*;  *Operating manual*.

Blank page

8.1.2

Overview of maintenance work on the superstructure

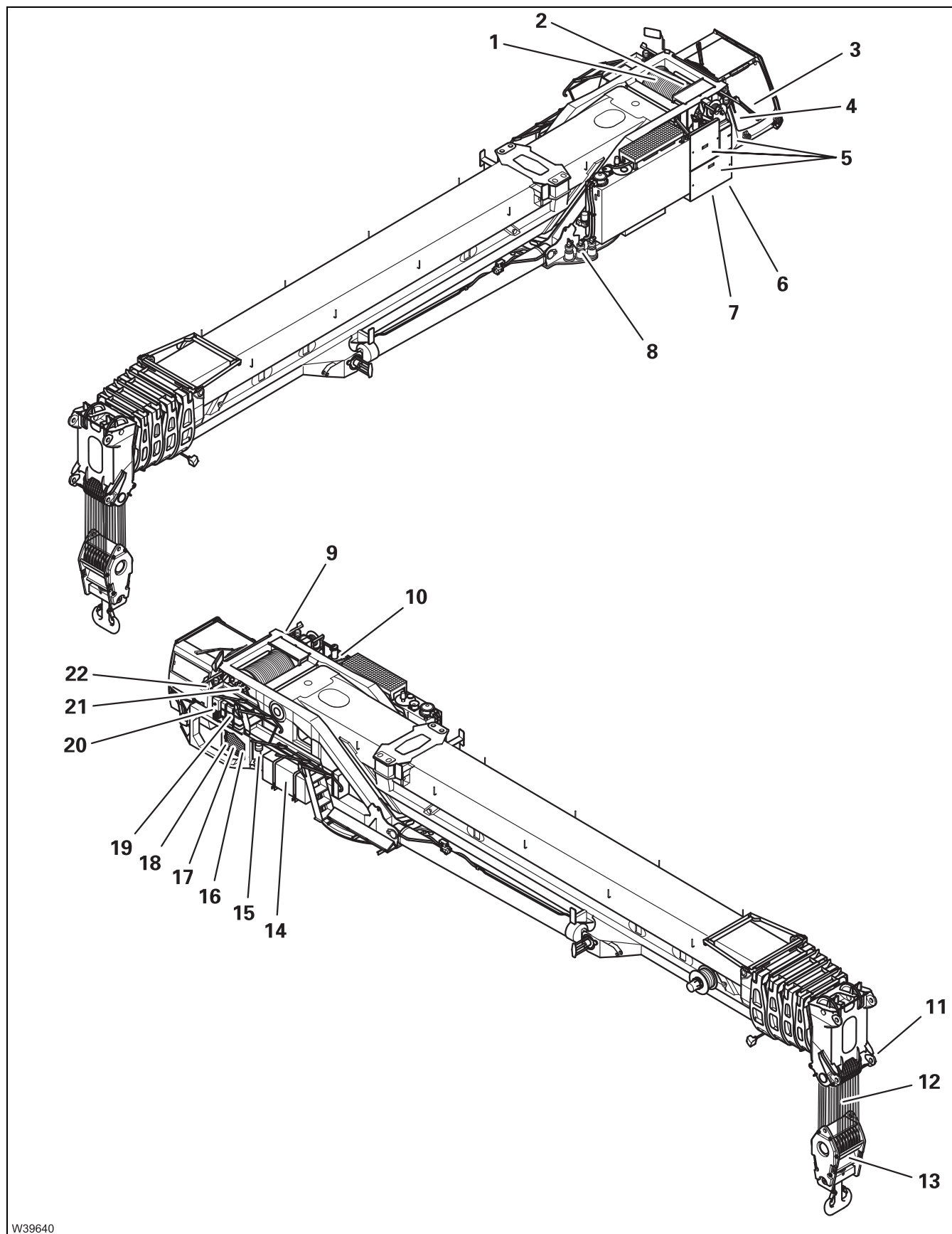

W39640

16.08.2018

Symbols for maintenance work	▣▣▣▣ P. 8 - 11
4 Side panel	▣▣▣▣ P. 8 - 11
3 ECOS display	▣▣▣▣ P. 8 - 12
Engine	▣▣▣▣ P. 8 - 13
7 Diesel engine	▣▣▣▣ P. 8 - 13
5 Covers	▣▣▣▣ P. 8 - 1
16 Dipstick	▣▣▣▣ P. 8 - 13
17 Oil filler opening	▣▣▣▣ P. 8 - 15
22 Air filter	▣▣▣▣ P. 8 - 16
20 Coolant reservoir	▣▣▣▣ P. 8 - 17
6 Oil filter	▣▣▣▣ P. 8 - 19
Fuel system	▣▣▣▣ P. 8 - 27
14 Diesel tank	▣▣▣▣ P. 8 - 27
15 Filter 1	▣▣▣▣ P. 8 - 28
18 Filter 2	▣▣▣▣ P. 8 - 31
Exhaust system with exhaust emission control	▣▣▣▣ P. 8 - 35
19 AdBlue tank	▣▣▣▣ P. 8 - 36
10 Exhaust silencer with filter and catalytic converter	▣▣▣▣ P. 8 - 37
Hoists	▣▣▣▣ P. 8 - 43
12 Hoist ropes	▣▣▣▣ P. 8 - 97
2 Rope wedges	▣▣▣▣ P. 8 - 98
1 Rope drums	▣▣▣▣ P. 8 - 97
9 Oil inspection glasses	▣▣▣▣ P. 8 - 43
13 Hook block	▣▣▣▣ P. 8 - 115
11 Rope end fitting	▣▣▣▣ P. 8 - 98
21 Lowering limit switch	▣▣▣▣ P. 8 - 109
Slewing gear	▣▣▣▣ P. 8 - 49
8 Oil inspection glasses	▣▣▣▣ P. 8 - 49



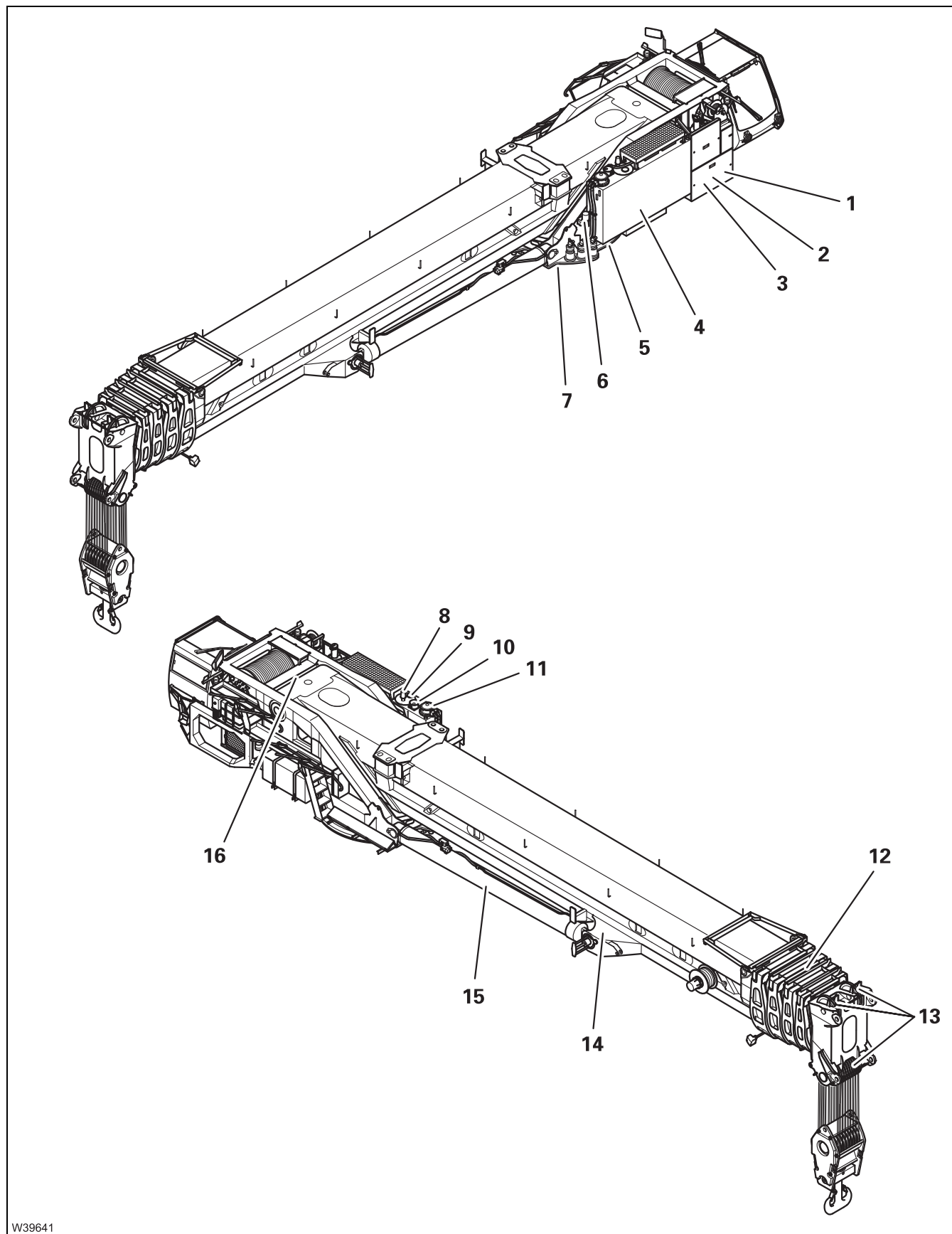

W39641

16.08.2018

Slewing bearing	▣▣▣▣▶ P. 8 - 55
5 Gear teeth	▣▣▣▣▶ P. 8 - 59
7 Turntable lock	▣▣▣▣▶ P. 8 - 64
Pump transfer case	▣▣▣▣▶ P. 8 - 65
1 Oil level plug	▣▣▣▣▶ P. 8 - 65
Hydraulic system	▣▣▣▣▶ P. 8 - 69
4 Oil tank with sight glass	▣▣▣▣▶ P. 8 - 69
9 Oil filler opening	▣▣▣▣▶ P. 8 - 82
8 Ventilation filter	▣▣▣▣▶ P. 8 - 75
3 Pressure accumulator	▣▣▣▣▶ P. 8 - 76
11 Oil filter 1	▣▣▣▣▶ P. 8 - 79
10 Oil filter 2	▣▣▣▣▶ P. 8 - 80
2 Oil filter 3	▣▣▣▣▶ P. 8 - 81
Main boom	▣▣▣▣▶ P. 8 - 85
12 Telescopic sections 1 to 4 and basic section	▣▣▣▣▶ P. 8 - 86
15 Derricking cylinder	▣▣▣▣▶ P. 8 - 85
13 Sheaves	▣▣▣▣▶ P. 8 - 94
Cable drums and slewing angle sensor	▣▣▣▣▶ P. 8 - 111
14 Cable drum 1	▣▣▣▣▶ P. 8 - 111
16 Cable drum 2	▣▣▣▣▶ P. 8 - 111
Central lubrication system	▣▣▣▣▶ P. 8 - 113
6 Centralized lubrication pump	▣▣▣▣▶ P. 8 - 113



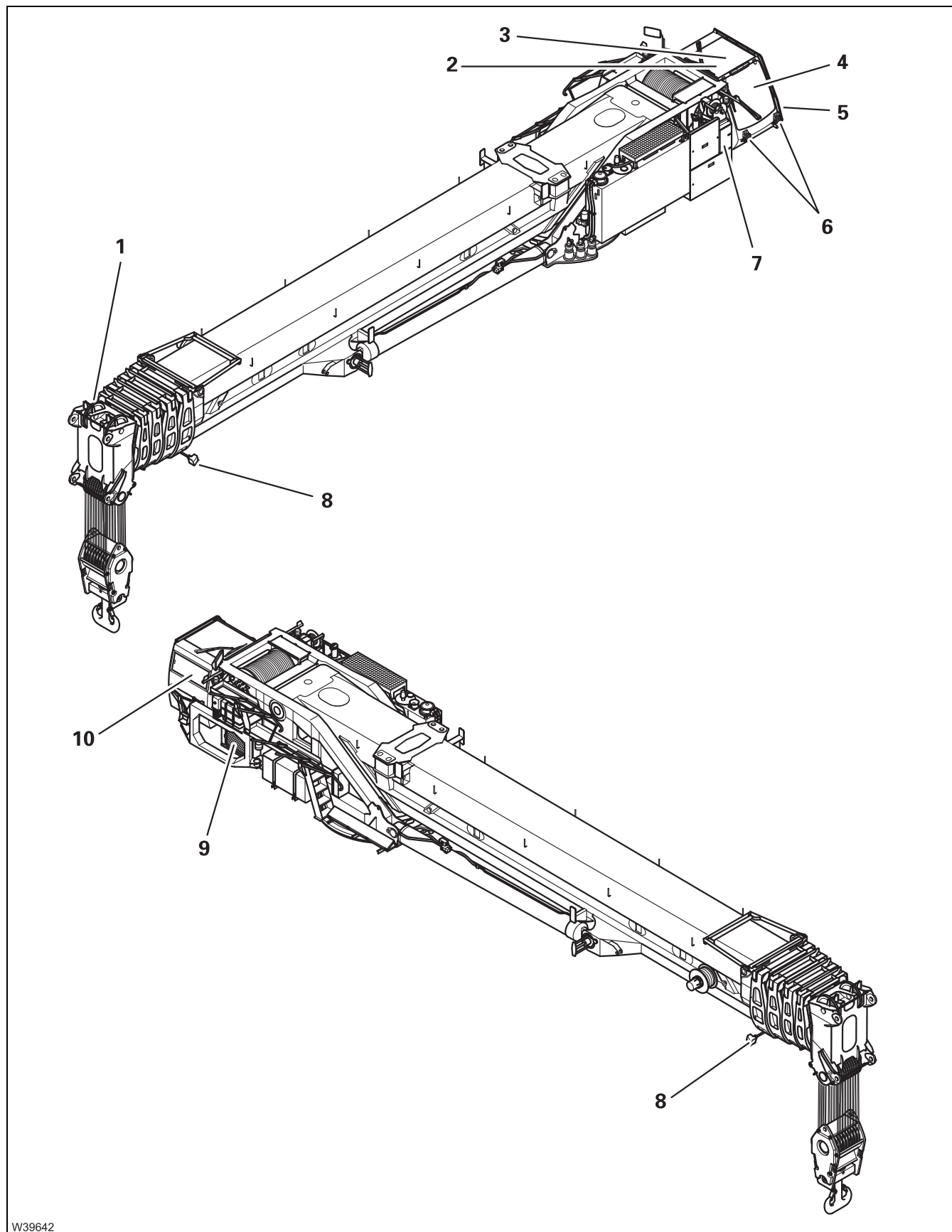

W39642

16.08.2018

Electrical system	▣▣▣▣▶ P. 8 - 117
6 Spotlights on the crane cab	▣▣▣▣▶ P. 8 - 117
8 Spotlights on the telescopic boom	▣▣▣▣▶ P. 8 - 117
1 Anemometer, air traffic control light	▣▣▣▣▶ P. 8 - 117
7 Battery box	▣▣▣▣▶ P. 8 - 118
Air-conditioning system	▣▣▣▣▶ P. 8 - 121
10 Crane cab air conditioning system ¹⁾	▣▣▣▣▶ P. 8 - 121
9 Condenser fins	▣▣▣▣▶ P. 8 - 122
Other maintenance work	▣▣▣▣▶ P. 8 - 125
5 Windscreen washing system reservoir	▣▣▣▣▶ P. 8 - 125
4 Crane cab auxiliary heater ¹⁾	▣▣▣▣▶ P. 8 - 126
3 Cab door rails	▣▣▣▣▶ P. 8 - 127
– Various connecting pins and socket pins	▣▣▣▣▶ P. 8 - 128
– Corrosion protection	▣▣▣▣▶ P. 8 - 129
2 Fire extinguisher ¹⁾	▣▣▣▣▶ P. 8 - 131

¹⁾ Additional equipment

Blank page

8.2

Symbols for maintenance work

- Check the following lamps and symbols on the side panel and ECOS display on a daily basis before you start work.

On the side panel

If one of the lamps on the side panel is lit in the driver's cab you must carry out the corresponding maintenance work:

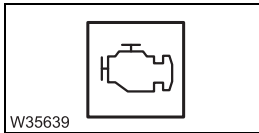

- Engine malfunction;  P. 8 - 13,

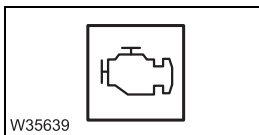

- Air filter;  P. 8 - 16,

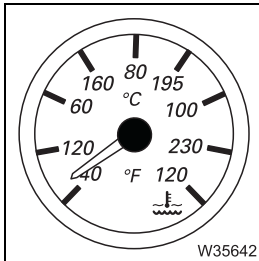

- Engine coolant level (temperature display);  P. 8 - 17,









- AdBlue system;  P. 8 - 36.

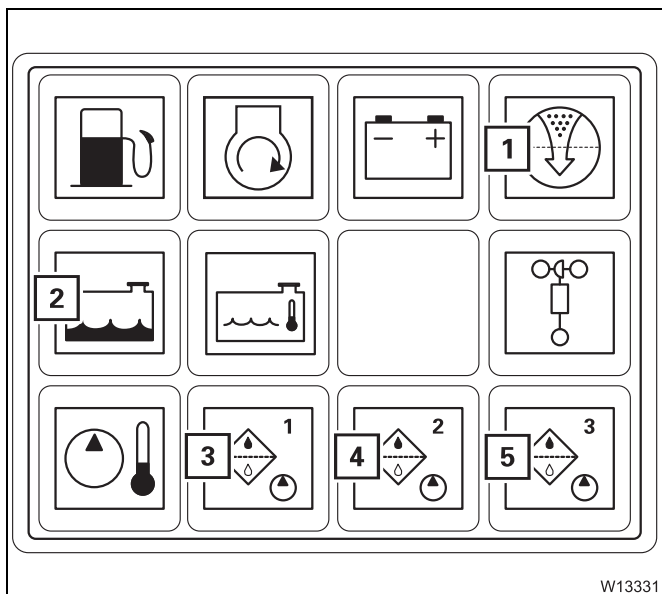

On the ECOS display

- Open the *Warning* submenu in the crane cab;  *Operating manual*.
You must carry out the corresponding maintenance work if a symbol is **rot**:



- 1 Air filter;  P. 8 - 16
- 2 Coolant level;  P. 8 - 17
- 3 Hydraulic oil filter 1;  P. 8 - 78.
- 4 Hydraulic oil filter 2;  P. 8 - 78.
- 5 Hydraulic oil filter 3;  P. 8 - 78.

8.3

Engine

- In addition, carry out further maintenance work specified in the *Engine manufacturer's documentation* supplied.

8.3.1

Check the oil level

D

Prerequisites

- The truck crane must be level.

Check the oil level

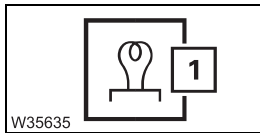

- After switching on the ignition, wait until the pre-heating lamp (1) goes out.
- Start the engine.

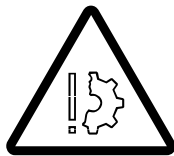

Risk of damage to the engine if the oil pressure is too low!

If the lamp (2) goes on, switch off the engine immediately.

Running the engine when the oil pressure is too low can damage it.

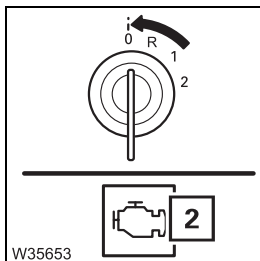

- **Switch off the engine immediately, if**
 - The lamp (2) lights up,
 - and the warning buzzer sounds.

If the lamp (2) goes on then an engine fault is present and you must have the error read. For example, the oil pressure could be too low.

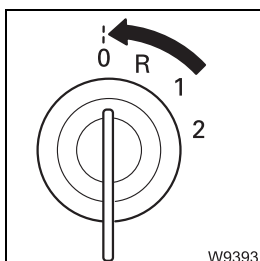

- Allow the engine to run at idling speed for 2–3 minutes.
- Switch the engine off.
- Check the oil level after a few minutes.



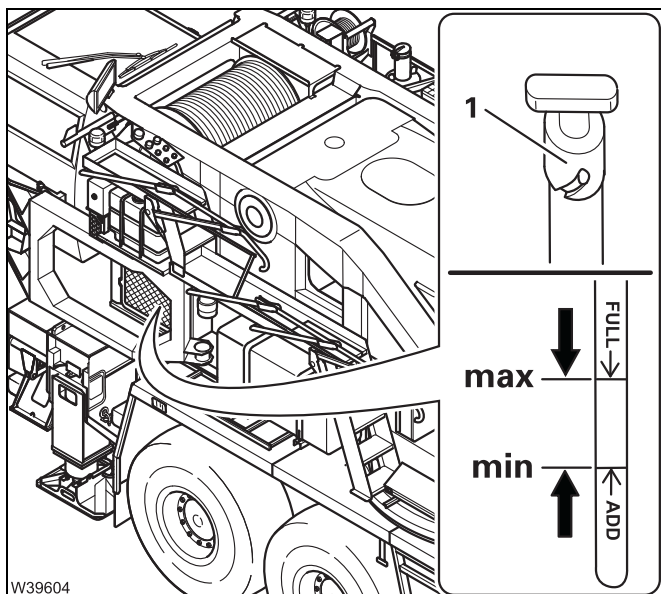

- On the dipstick (1), check that the oil level is between the **Min.** and **Max.** marks (arrow markings).
- After checking the oil level, put the dipstick back in the dipstick tube.

If the oil level is too low

- Top up with oil;  P. 8 - 15.

8.3.2

Topping up the oil

Data on the prescribed oil specifications;  *Engine manufacturer's documentation.*

Oil

Engine oil in litres (gal)	Designation to DIN 51502	Specifications Classification	GROVE part no.
17 (4.5)	HD - CD	CES 20081 Cummins	SAE 15 W-40 04162428

Prerequisites

- The truck crane must be level.
- The engine must not be running and must be secured against unauthorised use;  P. 2 - 3.

Topping up the oil



Risk of damage to the engine if the oil level is too high!

Do not overfill with oil; the oil level must not be higher than the **max.** mark (arrow marking). Drain off oil if necessary;  *Engine manufacturer's documentation.*



Risk of burns when the engine is hot!

During operation, the engine and add-on parts reach temperatures up to 400 °C (750 °F). Wear appropriate protective gloves and be careful not to touch hot parts.

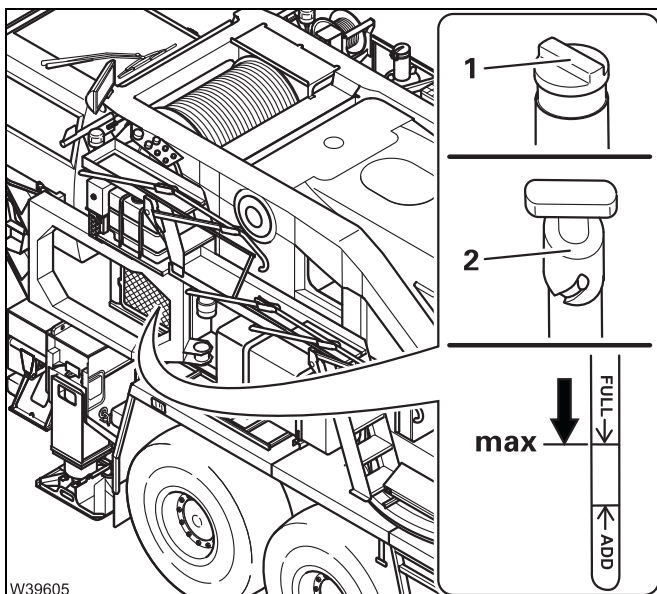

- Add oil through the filler neck (1) up to the **Max.** mark.
- Close the filler neck with the cap.
- Insert the dipstick (2) into the dipstick tube after checking the oil level.

8.3.3

Checking the air filter

D

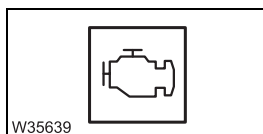

When the engine malfunction lamp on the side panel lights up then the air filter might be clogged.

- Also check the symbol on the ECOS display; ■■■► P. 8 - 12.

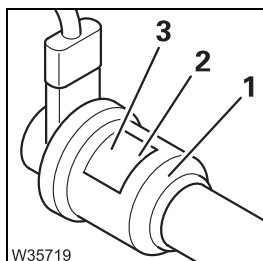

- Also check the visual pressure indicator (1) directly on the air filter. If the visual pressure indicator is in the red area (2) (CHANGE), then the air filter is clogged (100%). The green region (3) provides a prior indication of how heavily the air filter is contaminated (30%, 75%).

Spare parts and tools

Designation	Quantity	GROVE part no.
Main filter	1	04256761
Back-up filter	1	04256762

Prerequisites

- The engine must not be running and must be secured against unauthorised use; ■■■► P. 2 - 3.

Replace air filter

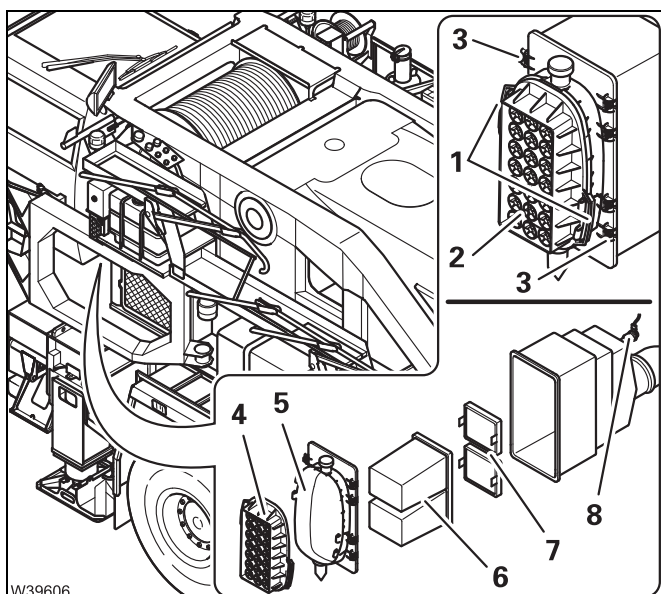

- Loosen the clamps (1).
- Remove the cover (2) and clean the inside of the coarse filter (4).
- Loosen all clamps (3).
- Remove the cap (5).
- Change the main filter (6) and the back-up filter (7).
- Fasten the cover (5) and secure it with all the clamps (3).
- Fasten the cover (2) and secure it with all the clamps (1).
- Reset the visual pressure display (8).

8.3.4

Checking the coolant level

D

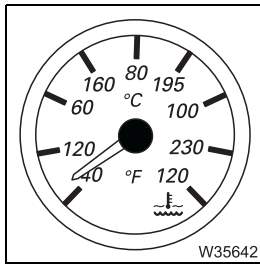

Monitor the coolant temperature on the display on the side panel during crane operation.

A major increase in temperature can be caused by a loss of coolant.

- Also check the symbol on the ECOS display; P. 8 - 12.

Topping up coolant



There is a risk of scalding when the cooling circuit is hot!

The hot cooling circuit is under pressure. When you open the expansion tank, you could be scalded by escaping vapour/coolant.

Wear suitable protective gloves and cover the cap on the expansion tank with a rag before opening it.

Turn the cap slowly to the first detent in order to allow the pressure to be released.

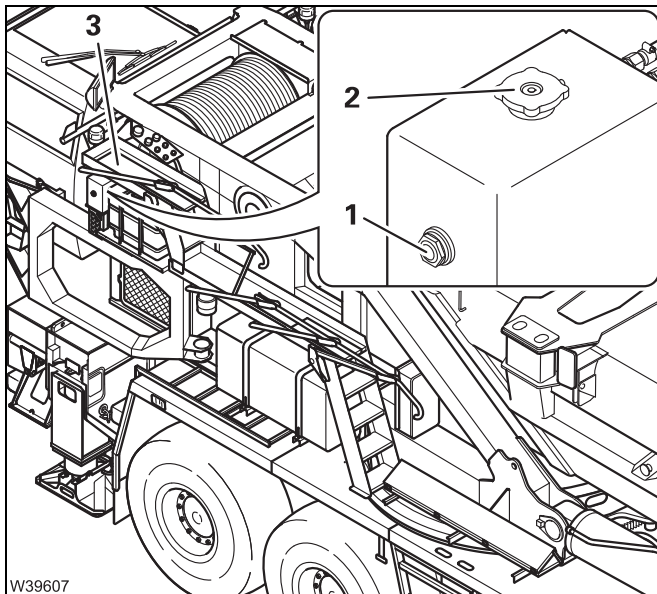

- Check the coolant level via the inspection glass (1).

If the coolant level is too low

The cover (2) is accessible from above through the opening (3) in the platform.

- Loosen (do not open) the cap (2) to reduce the pressure if the coolant is at operating temperature.
- Open the cap (2).
- Top up the coolant.
Composition of the coolant; *Engine manufacturer's documentation.*
- Close the cap (2).



Risk of damage to engine due to lack of coolant!

If the coolant has to be topped up frequently, the cooling system may be leaking. Have the cooling system checked by **Manitowoc Crane Care** or an authorised GROVE dealer or your repair crew.

8.3.5

General inspection

W

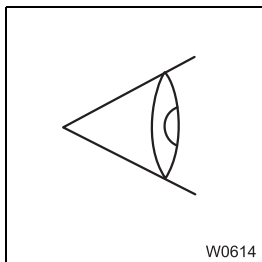

- Investigate any unusual running noises from the engine.
- Check the engine and the connections for leaks. If consumables are leaking;
 - ▣▣▣▣▶ *Check the oil level, P. 8 - 13,*
 - ▣▣▣▣▶ *Checking the coolant level, P. 8 - 17.*
- Check that pipes and hoses are tightly connected and undamaged.

If any damage is found, report it to **Manitowoc Crane Care** or an authorised GROVE dealer or your repair crew.

8.3.6

Changing the oil and the oil filter

M 6



**Oil, spare parts,
tools**

Engine oil in litres (gal)	Designation to DIN 51502	Specifications Classification	GROVE part no.
17 (4.5)	HD - CD	CES 20081 Cummins	SAE 15 W-40 04162428

Designation	Quantity	GROVE part no.
Oil filter with gasket	1	9414101679
Gasket for oil drain plug	1	03042029

– Receptacle, approx. 17 l (4.5 gal);  P. 2 - 4.

Prerequisites

- Find out the prescribed oil specifications and about the need to shorten the maintenance interval under special operating conditions;  *Engine manufacturer's documentation.*
- The truck crane must be level.
- The superstructure must be turned so that it is at right angles to the carrier – the engine is then more easily accessible from below.
- The engine must not be running and must be secured against unauthorised use;  P. 2 - 3.



Changing



Risk of environmental damage due to leaking consumables!

Always let consumables drain into suitable receptacles. Wipe up any consumables that escape.

Store/dispose of consumables and any soaked equipment properly.

Ask about the applicable regulations.



Risk of environmental damage due to leaking consumables!

Use the supplied connecting piece and hose and a receptacle with sufficient capacity to drain the oil.

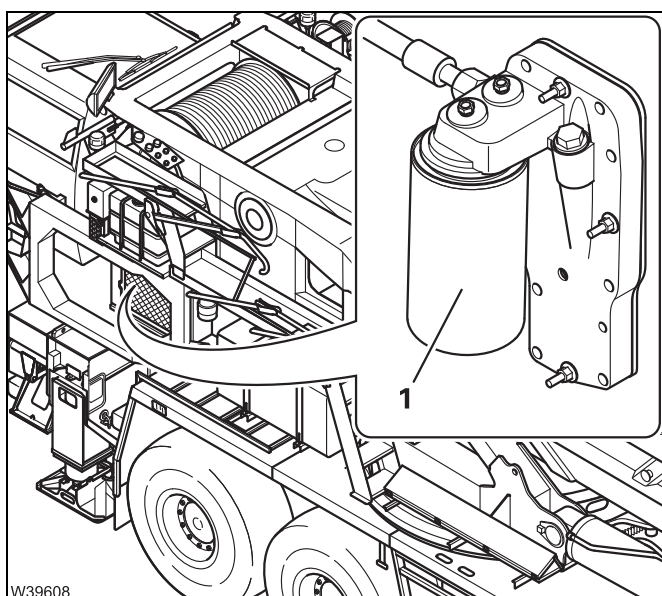

Oil filter

- Place a receptacle underneath the engine.
- Loosen the oil filter (1) using a strap wrench.
- Leave the receptacle in place for the oil change.

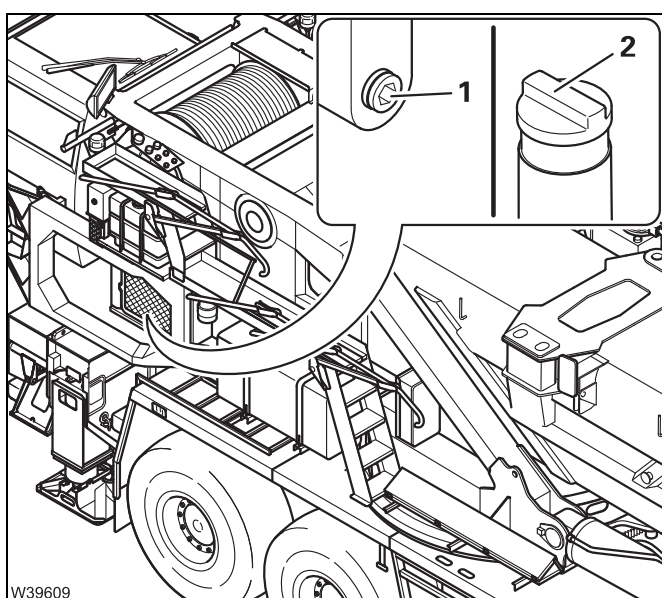

Draining oil

The drain plug (1) is accessible from below, at the side of the shallow oil pan.

- Unscrew the drain screw (1) and drain the oil into the container.
- Fit a new gasket and tighten the drain screw (1).
- Remove the receptacle.

Topping up the oil

- Top up with fresh oil through the filler neck (2);  P. 8 - 15.

8.3.7

Have the radiator checked/cleaned

M 12

Reducing the interval

- Under difficult operating conditions – at extremely sandy or dusty locations or if there is a heavy density of fallen leaves – you must have the radiator fins cleaned earlier than this.

Prerequisites

- The engine must not be running and must be secured against unauthorised use; ►► P. 2 - 3.
- Trained repair crew and repair tools must be available.

Check the level of dirt

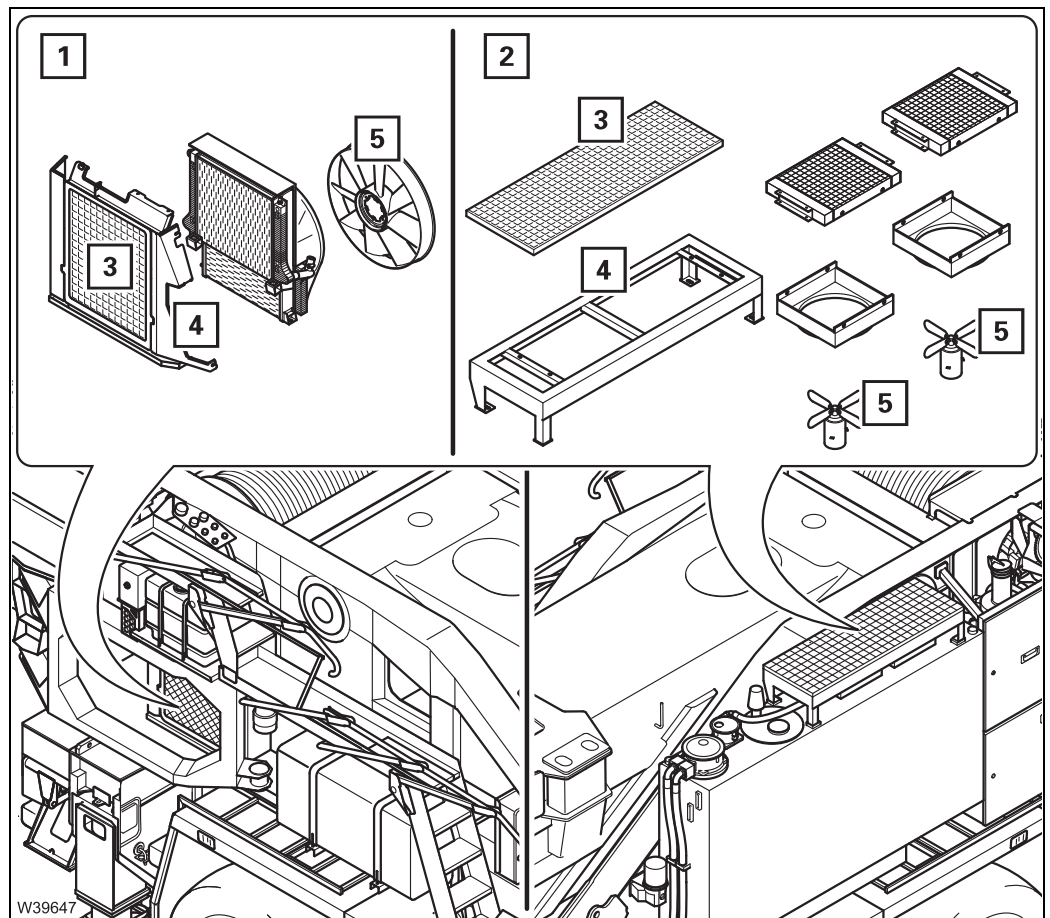

The two radiator units (1) and (2) are protected by grilles (3) and plates (4). When the engine is running, the fan impellers rotate (5).



Risk of injury at the fan wheel!

When the fan impellers are rotating they can trap the fingers of your hand and amputate them. Never reach into the fan impellers when they are rotating. Do not push any tools through the grilles to clean them. Always stop the engine before attempting to clean the fan impellers and radiator fins.

Radiator unit (1)

Radiator for the engine cooling water, radiator for the engine charge air.

Radiator unit (2)

Radiator for the hydraulic oil.

Standard equipment: 1 radiator; Additional equipment: 2 radiators.

Checking

- If necessary remove leaves, twigs and other debris from the grilles (3).
- Check the condition of the fan impellers (5). The impeller blades must be clean and undamaged.



If the radiator fins are heavily soiled have them cleaned, since further soiling can lead to overheating;  *Have them cleaned*, P. 8 - 23.

**Have them
cleaned**



Risk of injury at the fan wheel!

When the fan impeller is rotating it can trap the fingers of your hand and amputate them. Never reach into the fan impeller when it is rotating. Do not push any tools through the impeller to clean it.

Always stop the engine before attempting to clean the fan wheel and radiator fins.



Risk of damaging the radiator fins!

Do not use a high pressure cleaner or steam jet cleaner. The powerful jet may damage the fins.

Use only suitable cleaning agents air for cleaning.

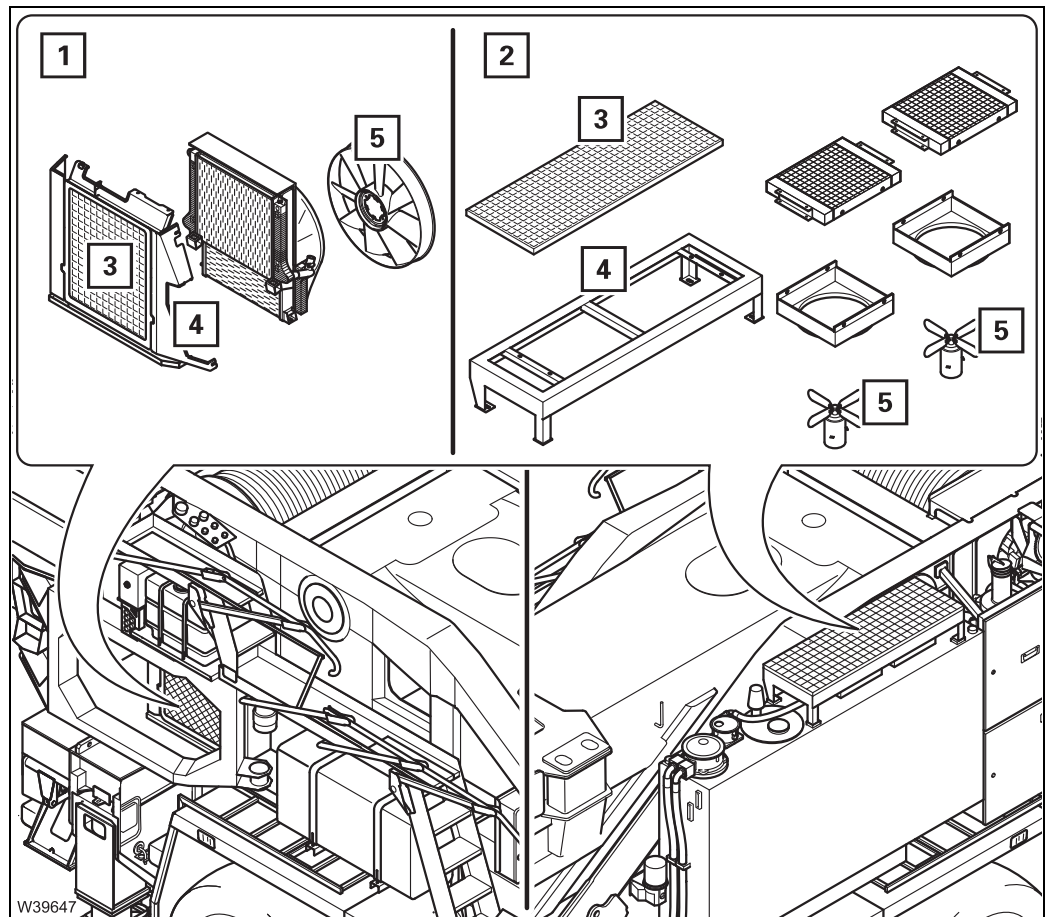

- Have the radiator units (1) and (2) opened up by the repair specialists, so that the radiator fins are accessible.
- Have the radiator fins cleaned on both sides, using suitable cleaning agents.
- Have the fan wheels (5) cleaned.
- Have the grille (3) and the plates (4) cleaned.
- Have the hoses and connections checked for damage and leaks.
- Have any damaged parts replaced.

**After checking/
cleaning**



- Remove all tools and cleaning equipment.
- Check that all the grilles (3) and plates (4) are secure.
- Start the engine and from a safe distance monitor the free running of the fan impellers (5).
- Check the respective temperature displays in the driver's cab;
 ▣▣▣▣▶ *Operating manual*.
- Switch the engine off.
- Check the radiator and connections for leaks.

8.3.8



Changing the coolant

M 12

Tools

- Receptacle, approx. 15 l (4 gal);  P. 2 - 4.
- Antifreeze;  *Engine manufacturer's documentation.*

Prerequisites

- Information on the coolant and admixture ratio has been obtained;
 *Engine manufacturer's documentation.*
- The engine must not be running and must be secured against unauthorised use;  P. 2 - 3.
- The engine has cooled down.



Risk of environmental damage due to leaking consumables!

Always let consumables drain into suitable receptacles. Wipe up any consumables that escape.
Store/dispose of consumables and any soaked equipment properly.
Ask about the applicable regulations.



There is a risk of scalding when the cooling circuit is hot!

The hot cooling circuit is under pressure. When you open the expansion tank, you could be scalded by escaping vapour/coolant.
Wear suitable protective gloves and cover the cap on the expansion tank with a rag before opening it.
Turn the cap slowly to the first detent in order to allow the pressure to be released.



Changing

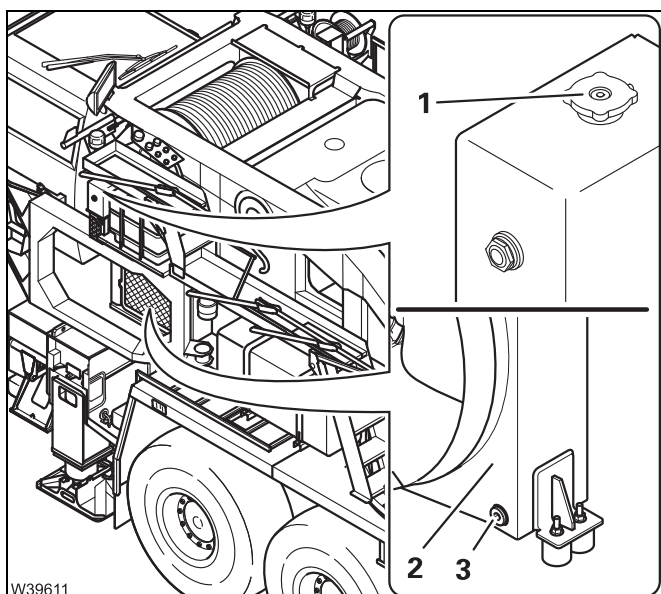

Draining when the engine is cold

- Open the cap (1) on the expansion tank.
- Place a container under the oil filter (2).
- Unscrew the drain plug (3) and let the oil drain off.
- If necessary fit a new gasket and tighten the screw (3).
- Remove the receptacle.

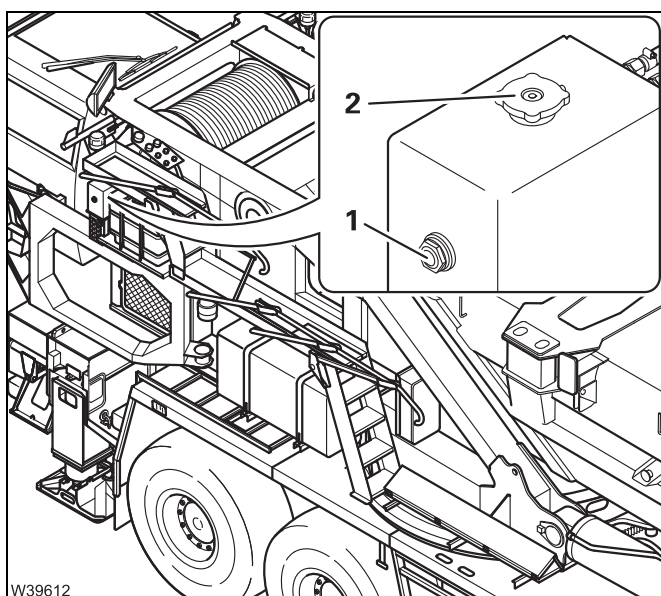

Topping up when the engine is cold

- Slowly top up the expansion tank (2) with coolant until it is filled up to the middle of the inspection glass (1).
- Wait about 1 minute. Add more coolant if necessary.
- Close the cover (2).

Check it when the engine is warm

- Start the engine.
- Let the engine run at idling speed for approx. 5 minutes.
- Switch the engine off.
- Check the coolant level when the engine is warm;  *Checking the coolant level, P. 8 - 17.*

8.4

Fuel system

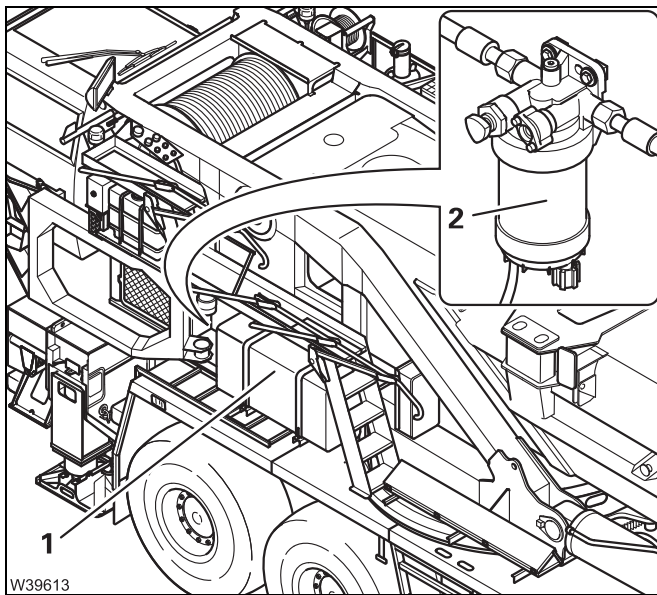

The following elements are installed in the superstructure fuel line:

- 1 Fuel tank
- 2 Fuel filter 1

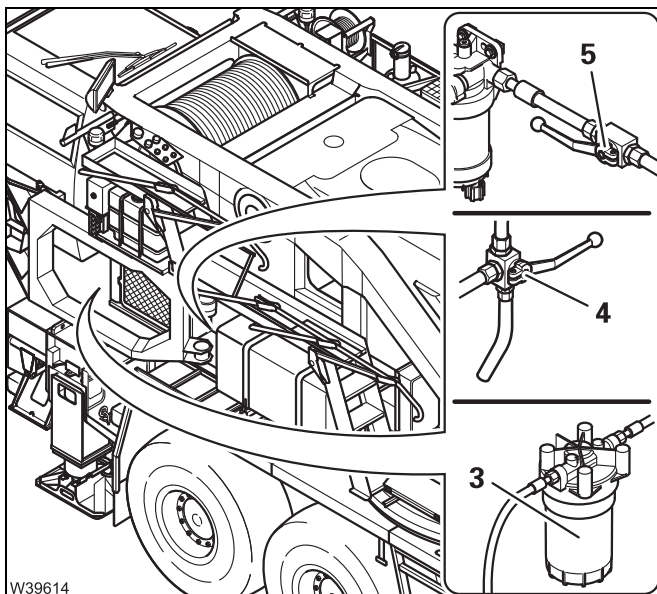

- 3 Fuel filter 2
- 4 3-way valve
in the return line;
for draining the fuel
- 5 Valve
in the supply line;
for shutting off the supply

8.4.1

Draining off water from fuel filter 1

D

Spare parts and tools

- Receptacle, approx. 5 l (1.5 gal);  P. 2 - 4.

Prerequisites

- The truck crane must be level.
- The engine must not be running and must be secured against unauthorised use;  P. 2 - 3.

WIF sensor

Fuel filter 1 is equipped with a chamber in the lower region that collects the separated water.

The sensor emits a signal when the chamber is full (WIF = Water in Fuel).

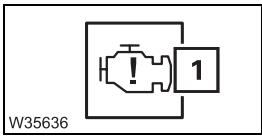

If the engine malfunction lamp (1) on the side panel lights up (have the error code read) then you must drain the water from fuel filter 1.

- Where possible, drain the water regularly before the sensor is triggered.
- Note that the quality of the fuel, and thus the water content, can vary greatly with the application location.
- **Daily** water draining may be necessary in the case of very low quality fuel.

Draining off water



Risk of environmental damage due to leaking consumables!

Always let consumables drain into suitable receptacles. Wipe up any consumables that escape.

Store/dispose of consumables and any soaked equipment properly.

Ask about the applicable regulations.

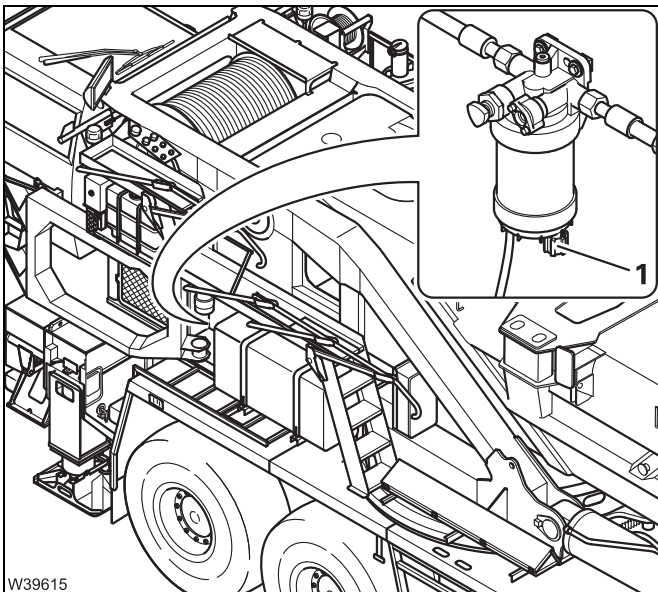

- Place a receptacle underneath the filter.
- Open the valve (1).
- If the consumable that emerges is clean, close the valve by hand.
- Remove the receptacle and properly dispose of the drained consumable.

8.4.2

Replacing fuel filter 1

M 6

Spare parts and tools

Designation	Quantity	GROVE part no.
Filter	1	04182148

- Receptacle, approx. 5 l (1.5 gal);  P. 2 - 4.

Prerequisites

- The truck crane must be level.
- The engine must not be running and must be secured against unauthorised use;  P. 2 - 3.
- If the fuel is dirty: Reduce the maintenance interval.

Changing



Risk of environmental damage due to leaking consumables!

Always let consumables drain into suitable receptacles. Wipe up any consumables that escape.

Store/dispose of consumables and any soaked equipment properly.

Ask about the applicable regulations.

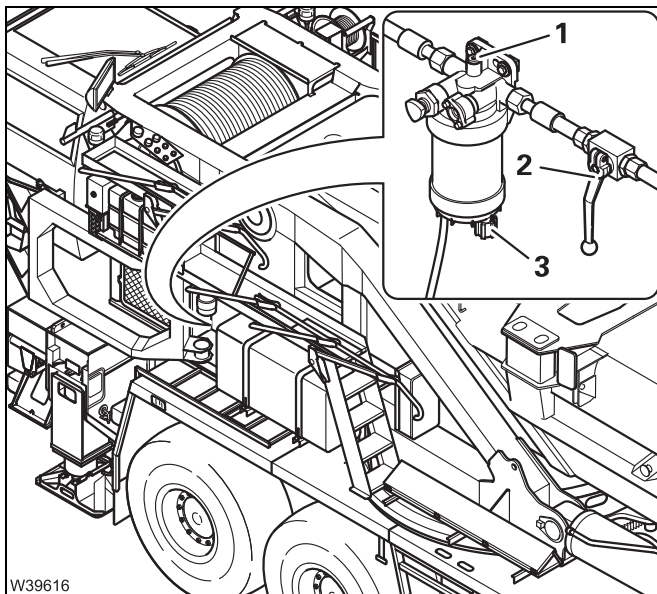

- Place a receptacle underneath the filter.
- Close the valve – lever (2) at right angles to the line.
- Open the screw (1) and the valve (3) and drain the consumable.



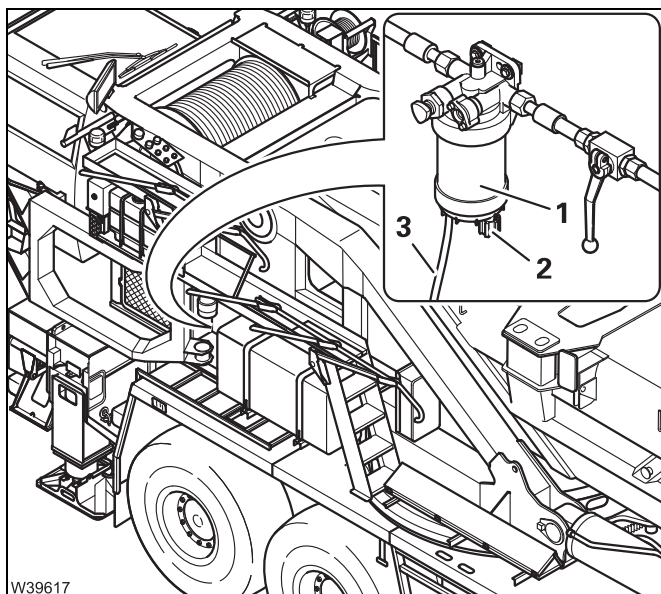

- Remove the electrical connecting cable (3) from the water sensor (WIF = Water in Fuel).
- Remove the filter (1).
- Screw on a new filter (1) and tighten it.
- Close the valve (2) manually.
- Attach the electrical connecting cable (3) to the water sensor (WIF = Water in Fuel).

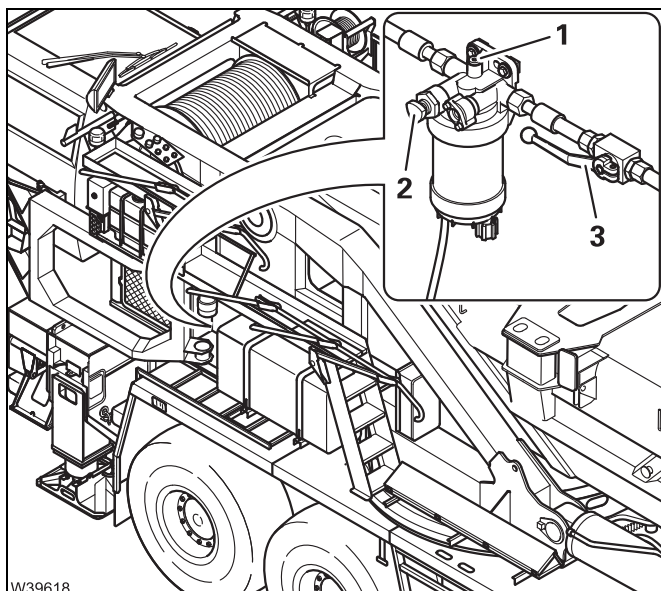

- Open the valve – lever (3) parallel to the line.
- Actuate the pump (2) until the fluid flowing out of the screw plug (1) no longer contains any bubbles.
- Close the drain plug (1).
- Start the engine and check for leaks.
- Remove the receptacle.



If you have used a clean receptacle, you can refill the fuel tank with the consumable using a filter.
Otherwise dispose of the consumable properly.

8.4.3

Replacing fuel filter 2

M 6

Spare parts and tools

Designation	Quantity	GROVE part no.
Filter	1	04182157

– Receptacle, approx. 5 l (1.5 gal); P. 2 - 4.

Prerequisites

- The truck crane must be level; *Operating manual*.
- The engine must not be running and must be secured against unauthorised use; P. 2 - 3.



Risk of environmental damage due to leaking consumables!

Always let consumables drain into suitable receptacles. Wipe up any consumables that escape.

Store/dispose of consumables and any soaked equipment properly. Ask about the applicable regulations.

Emptying the fuel line

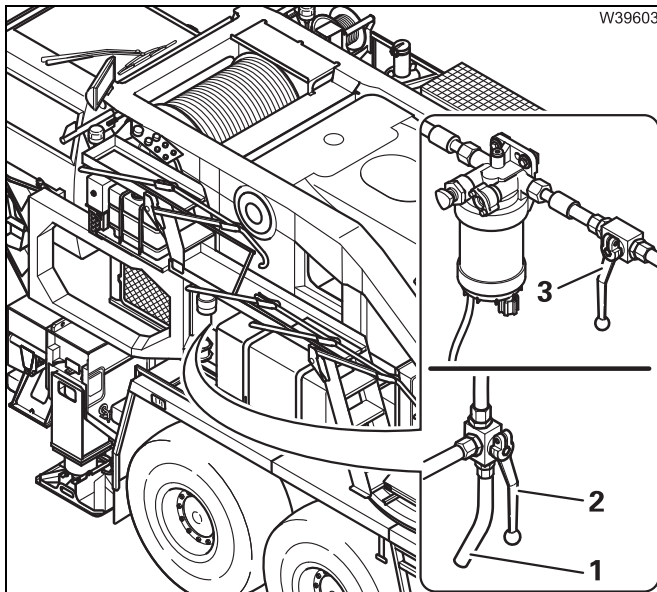

- Close the valve – lever (3) at right angles to the line.
- Place a receptacle under the end of the hose (1).
- Turn the valve – lever (2) parallel with the end of the hose (1).
- Let the consumable drain into the receptacle.

Leave the receptacle under the end of the hose. More consumable will run out when you bleed the fuel line.



Changing filter 2 The filter 2 is mounted on the inner side of the engine and is accessible from below.

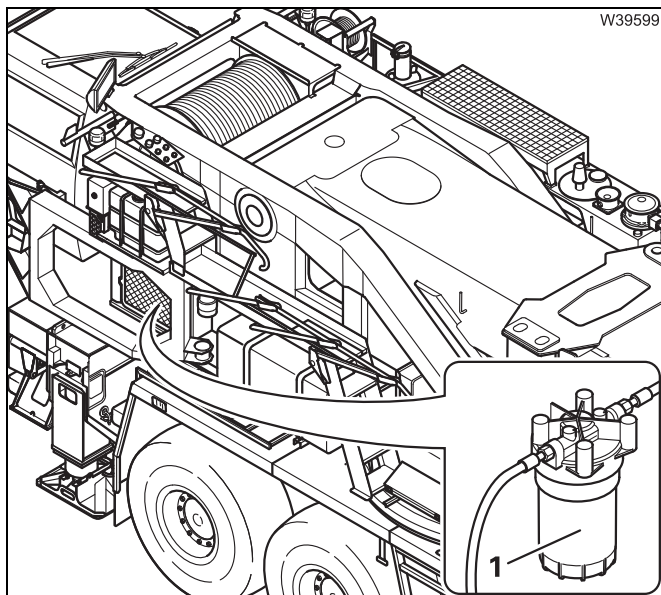

- Place a receptacle under the filter (1).
- Remove the filter (1).
- Fill a new filter (1) with clean consumable and screw it up (lightly grease the gasket).

Bleeding the fuel line

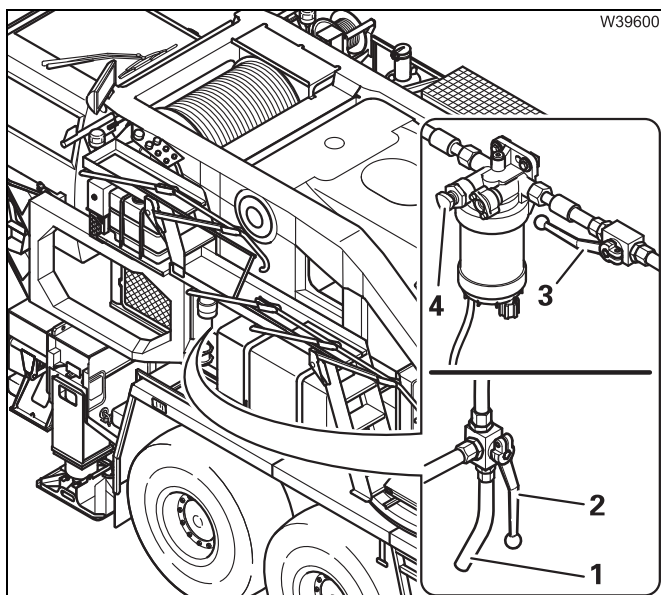

A receptacle is under the end of the hose (1). The lever (2) is parallel with the end of the hose.

- Open the valve – lever (3) parallel to the line.
- Actuate the pump (4) until the consumable flowing through the end of the hose (1) no longer contains any bubbles.

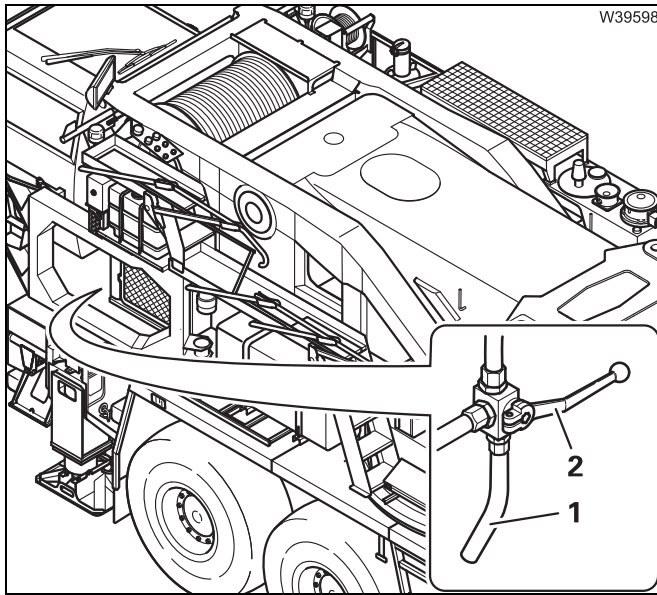

- Turn the valve – lever (2) at right angles to the end of the hose (1).
- Start the engine and check that the fuel filters are not leaking.
- Remove the receptacle under the end of the hose.



If you have used a clean receptacle, you can refill the fuel tank with the consumable using a filter.
Otherwise dispose of the consumable properly.

Blank page



8.5

Exhaust system with exhaust emission control

Overview

In order to adhere to the exhaust emission regulations, you are only permitted to drive the crane with the **multi-stage exhaust system** consisting of **DOC catalytic converter, DPF particle filter, SCR catalytic converter** (DOC = Diesel Oxidation Catalyst, DPF = Diesel Particulate Filter, SCR = Selective Catalytic Reduction).

The exhaust gas is cleaned with an **AdBlue system (DEF)**. **AdBlue (DEF)** (Diesel Exhaust Fluid) from the DEF tank is injected into the mixing tube in the exhaust system for this.

The motor output is automatically sharply reduced when there is not enough AdBlue solution available. Driving with an empty AdBlue tank will cause the engine to malfunction;  *Operating manual*,  *Engine manufacturer's documentation*.

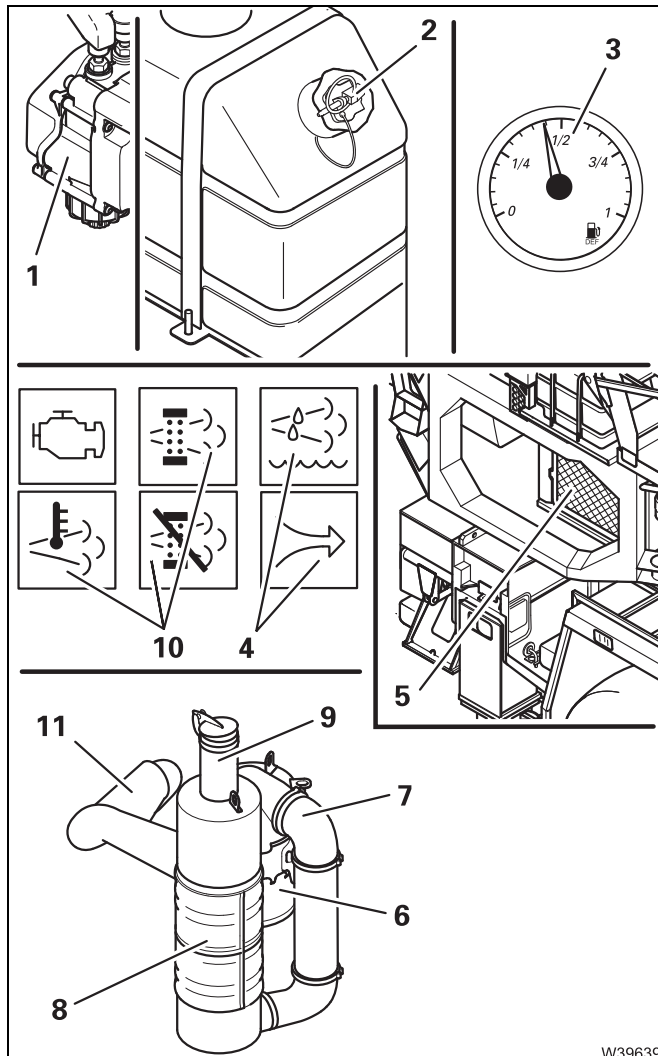

AdBlue system

- 1 Pump unit for pumping AdBlue to the dosing unit on the diesel engine and for pumping engine coolant for preheating the AdBlue tank.
- 2 AdBlue tank
- 3 Tank gauge, AdBlue tank
- 4 Warning lamps: AdBlue system fault.
- 5 Diesel engine with dosing unit for AdBlue (compressed air supply) and a solenoid valve for preheating the AdBlue tank using engine coolant.
- 6 Exhaust pipe: DOC catalytic converter and DPF particle filter.
- 7 AdBlue mixing tube with injection nozzle for injecting the AdBlue/compressed air mixture.
- 8 Exhaust pipe: SCR catalytic converter.
- 9 Exhaust end pipe
- 10 3 warning lamps: Exhaust gas temperature, active/passive regeneration of the exhaust gas filter.
- 11 Thermal insulation mat: behind the manifold on the engine.

8.5.1

Checking the AdBlue tank level

D

Checking

The warning lamp for checking the AdBlue system and a display for the AdBlue level in the tank is located on the side console in the crane cab.



The tank has a maximum filling volume of approx. 37.8 l (10 gal). Depending on where the truck crane is used, it may be sensible to carry additional canisters of AdBlue.

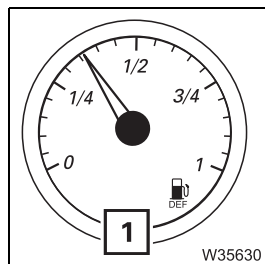

- Start the engine.
- Check the AdBlue level in the tank via the display (1) in the crane cab; *Operating manual*.
- Refill the tank when the AdBlue level falls below one quarter (1/4) at the very latest.

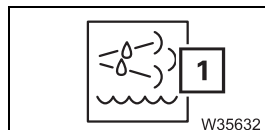

- Check the warning lamp (1). The lamp lights up when the AdBlue tank is empty or when a fault occurs in the AdBlue system.

8.5.2

Filling up with AdBlue

Consumable and tools

AdBlue in litres (gal)	Specifications Classification	GROVE part no.
37.8 (10)	DEF (Diesel Exhaust Fluid) e.g. <i>AdBlue</i> .	03140555

– As required: 2 canisters of about 20 l each (5 gal); P. 2 - 4.

Prerequisites

- A service station with a filling pump for AdBlue can be used, or AdBlue can be filled manually from canisters.
- The engine must not be running and must be secured against unauthorised use; P. 2 - 3.

Refuelling

- Find out about filling up in the operating manual and note the warnings;  *Operating manual.*



Danger of scalding due to ammonia vapours!

Ammonia vapour can escape if the AdBlue tank is opened when the outside temperature is high. Ammonia vapours can irritate mucous membranes, skin and eyes.

Ensure that there is adequate fresh air supply and do not breathe in the escaping ammonia vapours.

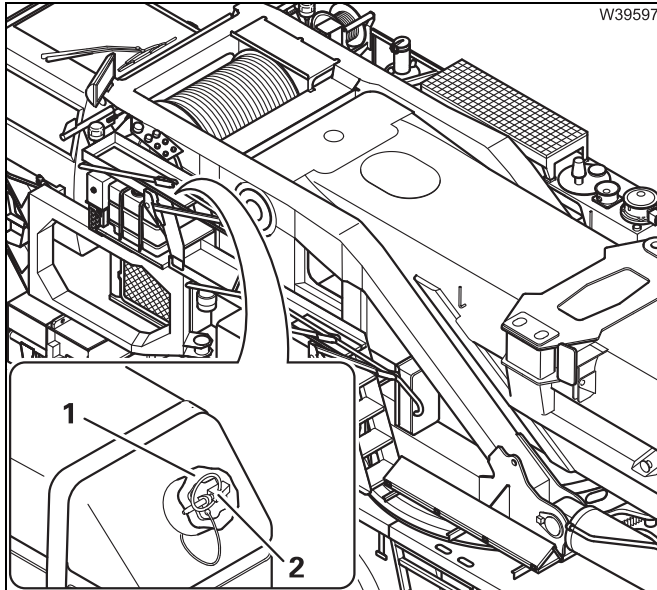

- Fill the AdBlue tank via the filler neck (1) and close it using the cap.
- Secure the cap with the securing plug (2).
- Check the filling level on the display in the crane cab;  P. 8 - 36.

8.5.3

Check the exhaust system for external damage

M 1

Spare parts and tools

Designation	Quantity	GROVE part no.
Entire exhaust system	1	04168803
– DOC catalytic converter + DPF particle filter	1	04168812
– AdBlue mixing tube	1	04168809
– SCR catalytic converter	1	04168808

Prerequisites

- The engine must not be running and must be secured against unauthorised use;  P. 2 - 3.
- The engine and the exhaust system must be cool.



Checking



Risk of burns if the exhaust system is hot!

The exhaust system becomes extremely hot during operation.

Especially during the *regeneration phases*, the exhaust gas temperature can reach 600 °C (1100 °F).

Wear suitable gloves and wait until the exhaust system has cooled down.

Make sure not to touch any hot parts.

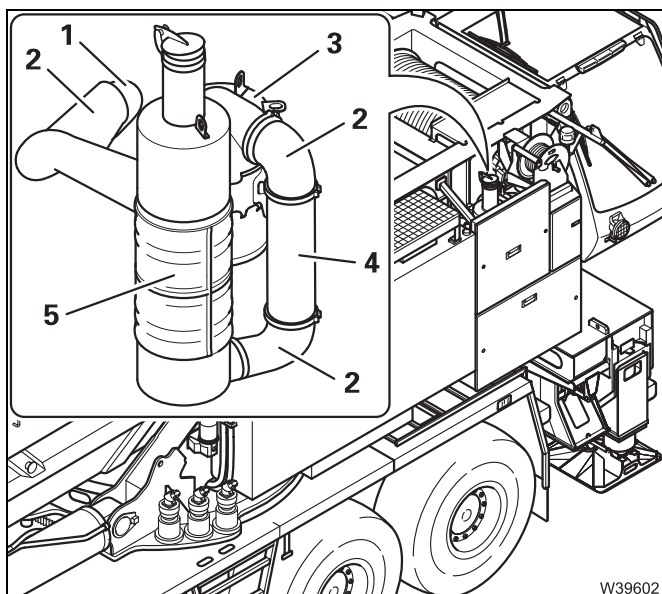

- Check the exhaust pipes (2) for damage, from the engine (1) to the DOC catalytic converter with DPF particle filter (3), the AdBlue mixing pipe (4), the SCR catalytic converter (5) and up to the end pipe. The exhaust pipes (2) may not have any loose clamps, holes or cracks.
- Check that the area around the exhaust pipes is free of loose components which could burn by coming into contact with the hot exhaust system.
- Check the mixing tube (4) at the inclined filler neck for injecting AdBlue for external damage.

After checking

- Start the engine.
- Check the lamp for the AdBlue system and the lamps for the exhaust system on the side console in the crane cab; P. 8 - 36; P. 8 - 40.
- Check whether exhaust gases are leaking from any damaged places in the exhaust system.
- Switch the engine off and allow it to cool down.

If you discover any damage

Have any damaged parts of the exhaust system replaced immediately by **Manitowoc Crane Care** or an authorised GROVE dealer.

8.5.4

Having the AdBlue system checked

M 12

This inspection may only be performed by **Manitowoc Crane Care** or an authorised GROVE dealer or an authorised specialist workshop!

- Have the entire AdBlue system checked for leaks and correct operation; *Overview*, p. 8 - 35.
- Also observe the information on the components mounted on the engine;
 ▣▣▣▣ *Engine manufacturer's documentation*:
 - AdBlue dosing unit,
 - Solenoid valve for engine coolant for preheating the AdBlue tank.

Maintenance interval for the pump unit

The engine manufacturer specifies additional maintenance intervals for the pump unit (1); ▣▣▣▣ *Engine manufacturer's documentation*.

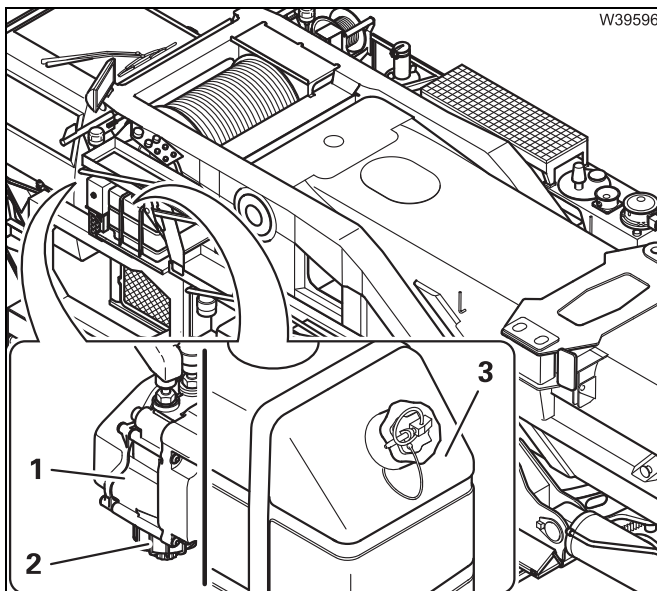

AdBlue filter

A diagnostic unit and special tools are required for this work.

The operating pressure must be discharged before replacing the filters.

- Have the AdBlue filter (2) in the pump unit (1) changed.
 Grove part no. 04182142.

The operating pressure must be adjusted anew after replacing the filters!

- Have the electrically heated AdBlue cables at the pump unit (1) checked for correct operation.

The AdBlue tank (3) can be fitted with an insulation hood as extra equipment.

- Have the insulation hood checked for damage and for tight fitting on the AdBlue tank. The insulation hood prevents the AdBlue tank freezing up.

8.5.5

Having the soot particle filter system checked

M 12

Checking daily

The exhaust system contains a soot particle filter (DPF particle filter).

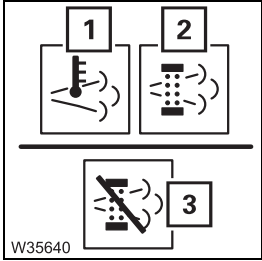

- Check the operating status of the exhaust system on a **daily** basis by checking the lamps (1) to (3) on the side console in the crane cab;
 ▶ *Operating manual*.
 - high exhaust gas temperature warning lamp (1),
 - passive regeneration (2),
 - active regeneration (3).



Under high loads (intensive crane operation for longer periods of time), the **passive** regeneration system ensures permanent conversion of the soot particles into gases that are then expelled. Under long periods of operation at low loads (brief crane operation with long pauses) the warning lights indicate that the system has switched over to **active** regeneration.

Active regeneration switches on automatically when the soot particle filter is in danger of clogging. When this occurs, more diesel is injected into the engine, which significantly increases the exhaust gas temperature and burns the soot filter free of soot.

Active regeneration can be manually suppressed (3), and specific soot-burning cycles are available; ▶ *Operating manual*; ▶ *Engine manufacturer's documentation*.

The soot particles are not completely burned away without residue, so that the ash must be removed after a long period of operation; ▶ P. 8 - 41.

Have the ash removed

The maintenance periods can fluctuate greatly depending on the truck crane operating conditions, fuel quality and engine oil quality. Under good operating conditions the ash must be removed after five years (Y 5), or 5,000 operating hours (5,000 oper. hrs.).

Service partner

- Have the particulate filter cleaned by service partners. Information can be obtained from **Manitowoc Crane Care**.

Prerequisites

- The engine must not be running and must be secured against unauthorised use;  P. 2 - 3.
- The exhaust system has cooled down.



Risk of burns if the exhaust system is hot!

During operation, the exhaust system can heat up to 600 °C (1100 °F). Wear suitable gloves and/or wait until the exhaust system has cooled down. Make sure not to touch any hot parts.



Soot particles can be a health hazard.

Soot particles are suspected of being hazardous to health. Wear appropriate dust respirator masks and be careful not to breathe in or ingest soot particles.



Risk of polluting the environment

Collect the combustion residues from the particulate filter in a suitable receptacle and dispose of them according to the relevant regulations.

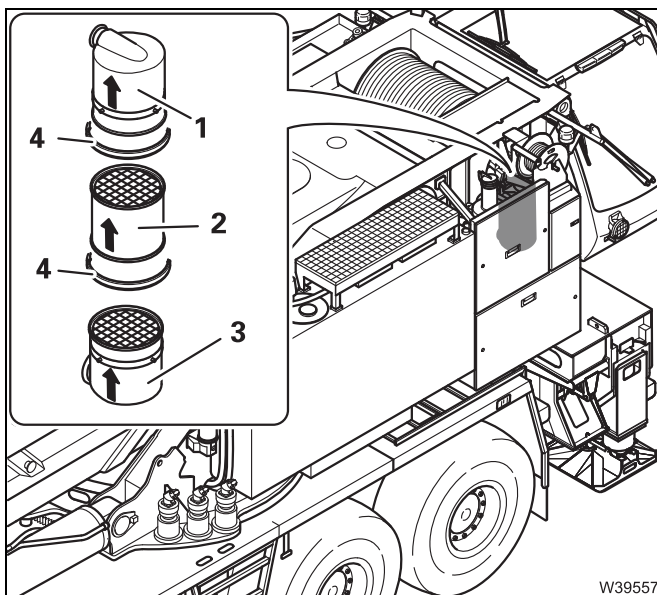

Have them removed

- Mark the exhaust flow direction on the parts.
- Release the tensioning straps (4) and remove the subsections one after another:
 - Inlet piece (3),
 - DPF particle filter (2),
 - Outlet piece (1).



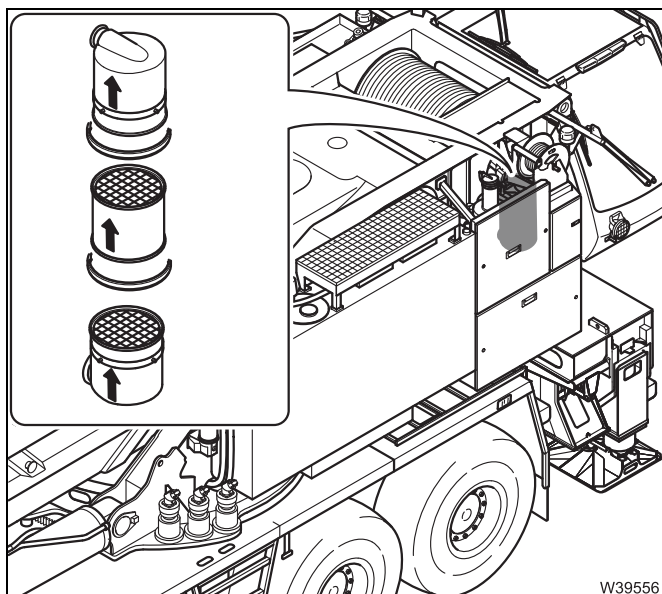

Have them cleaned

- Only clean the filter in a system approved by the filter manufacturer.
- Replacement filters are available from the filter manufacturer's service partner if you do not have a cleaning system available.
- If necessary, replace damaged filters and tensioning straps with defective seals.

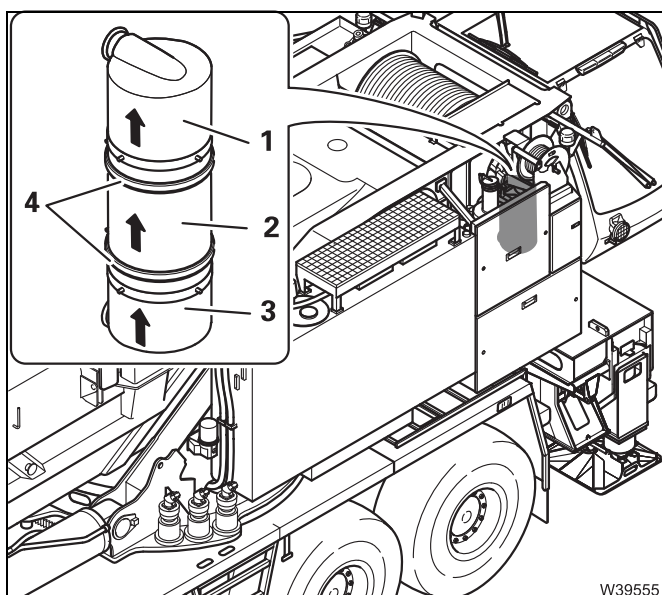

Have them installed

- Observe the exhaust flow direction markings on the parts.
- Assemble the subsections (1) to (3).
- Tighten the tensioning straps (4) to the specified torque.
- Ensure that the subsections are properly sealed to each other with the tensioning straps.
- Completely install the exhaust system.

- Have a back pressure test performed to check if the exhaust system is gas-tight.

If you discover any damage

Have any damaged parts of the exhaust system replaced immediately by **Manitowoc Crane Care** or an authorised GROVE dealer.

8.6

Hoists

8.6.1

Checking the oil level

W

Spare parts and tools

Designation	Quantity	GROVE part no.
Gasket 14 x 18 Cu DIN 7603	2	00117131
Gasket 18 x 22 Cu DIN 7603	4	00117137

Prerequisites

- The truck crane must be level and in on-road mode; *Operating manual*.
- The auxiliary hoist (additional equipment) is rigged; *Operating manual*.
- The engine must not be running and must be secured against unauthorised use; P. 2 - 3.

Checking the oil level

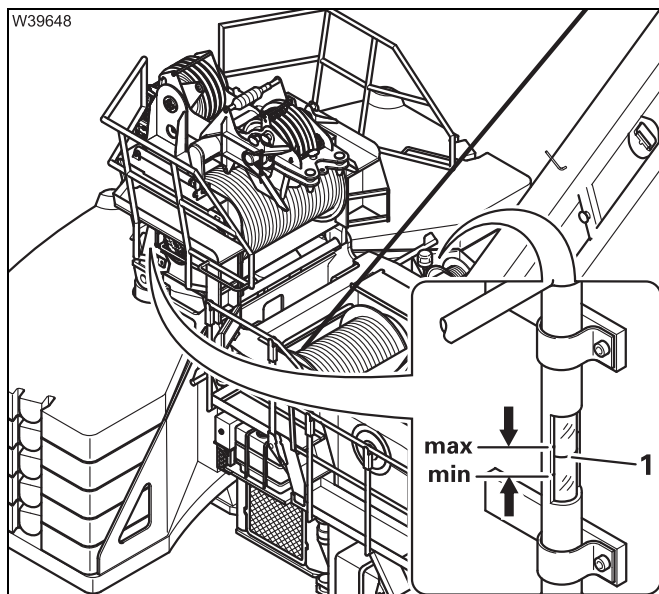

- Check that the oil level is visible between the **Min.** and **Max.** marks (1).

If the oil level is too low

- Top up the oil; P. 8 - 46.

8.6.2

General inspection

W

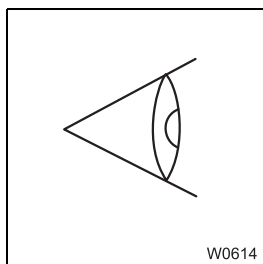

- Pay attention to any unusual running noises from the hoists.
- Check the hoists and the connections for leaks. If consumables are leaking;  *Checking the oil level*, P. 8 - 43.
- Check that pipes and hoses are tightly connected and undamaged.

If any damage is found, report it to **Manitowoc Crane Care** or an authorised GROVE dealer or your repair crew.

8.6.3

Checking the hoist brake

W

Check that the hoist brake is working correctly on the main hoist and the auxiliary hoist.

Main hoist

- Attach the hook block to the hoist rope, reeved once.
- Lift a test load of approx. 11.2 t (24 700 lbs) approx. 30 cm (1.0 ft) above the ground.
- Measure the distance to the ground when the load is hanging completely still.
- Switch the engine off.

If the load has not lowered after approx. 2 minutes, the brake is currently in working order.

If the load lowers, notify **Manitowoc Crane Care** or an authorised GROVE dealer.

Auxiliary hoist

- Carry out the check on the auxiliary hoist in just the same way as the main hoist, but use a load of approx. 10.0 t (22 045 lbs).

8.6.4

Lubricating the auxiliary hoist

M 6

Grease, spare parts, tools

Lubricating grease	Designation to DIN 51502	Specifications Classification	GROVE part no.
Grease	KP - 1K - 50	DIN 51825	03233369

- Grease gun from the tool set.

Prerequisites

- The engine must not be running and must be secured against unauthorised use; ►► P. 2 - 3.

Greasing



Risk of damage to the auxiliary hoist!

The auxiliary hoist drum bearing is **not** automatically lubricated by the centralised lubrication pump on the turntable.

Lubricate the auxiliary hoist drum bearing with the grease gun at the lubricating nipple.

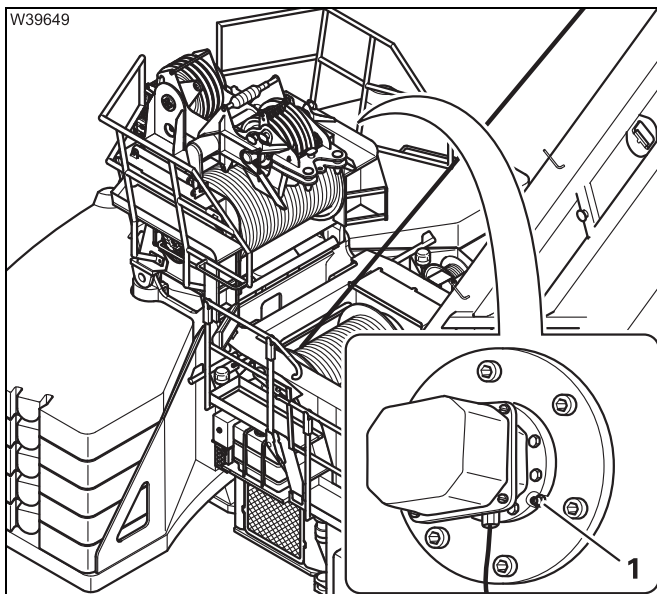

- Clean the lubricating nipple (1) and lubricate the hoist at the lubricating nipple.
- Remove any grease that has escaped.

8.6.5

Changing the oil/checking the oil

M 12

- Also adhere to the  *Run-in regulations*, P. 4 - 1.



Oil, spare parts, tools

Gear oil in litres (gal)	Designation to DIN 51502	Specifications Classification	GROVE part no.
11.5 (3.0) for each hoist	C - LPF	MIL-L 2105 B API-GL-4/5 Viscosity: SAE 75 W-90 EP ISO - VG 220	02313611 Synthetic oil; do not mix this with mineral-based oils!

Designation	Quantity	GROVE part no.
Gasket 14 x 18 Cu DIN 7603	2	00117131
Gasket 18 x 22 Cu DIN 7603	4	00117137
Gasket 26 x 31 Cu DIN 7603	4	00117147

- Receptacle, approx. 12 l (3.2 gal);  P. 2 - 4.
- Torque wrench for torque of 30 Nm (22.1 lbf ft).

Prerequisites

- The truck crane must be level and in on-road mode;  *Operating manual*.
- The auxiliary hoist (additional equipment) is rigged;  *Operating manual*.
- The engine must not be running and must be secured against unauthorised use;  P. 2 - 3.

Changing the oil at the hoist

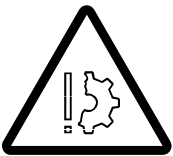

Risk of damage to the hoist gears!

The waste oil must be checked for abrasion particles. This inspection is used to detect any damage at an early stage;  P. 8 - 47.



Risk of environmental damage due to leaking consumables!

Always let consumables drain into suitable receptacles. Wipe up any consumables that escape.

Store/dispose of consumables and any soaked equipment properly. Ask about the applicable regulations.



During filling, the oil spreads only slowly in the hoist. The oil level therefore rises quickly in the standpipe at first, then drops slightly and then eventually rises again to its true level.

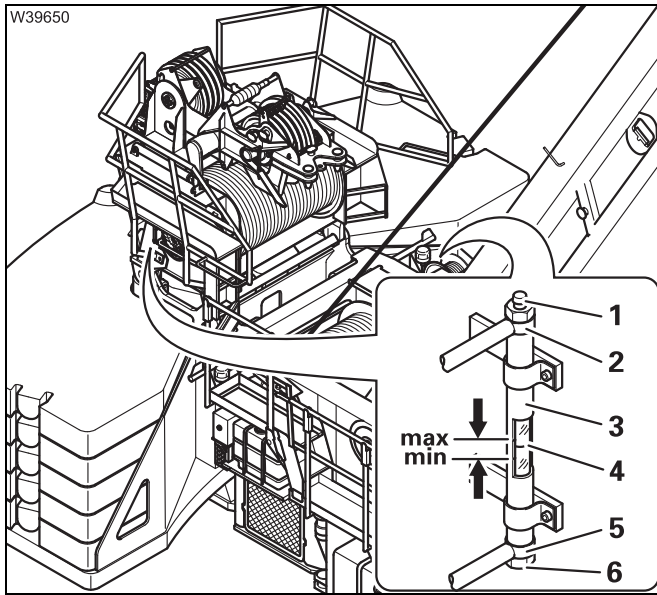

Draining oil

- Place a receptacle under the pipe (3).
- Unscrew bolts (1) and (6) and allow the oil to drain.
- Replace the gaskets and secure the hose (5) with the screw (6) – torque 30 Nm (22.1 lbf ft).

Topping up the oil

- Fill the oil through the pipe (3) up to the **Max.** mark (4).
- Replace the gaskets and secure the hose (2) with the screw (1) – torque 30 Nm (22.1 lbf ft).

Checking the oil



Risk of accidents from falling load!

If this inspection is not performed, there is a risk of damage to the hoist gear which could lead to the load falling.



Check the waste oil for abrasion particles or have it tested in a laboratory:

- Pour the waste oil through a clean filter mat.
- Examine the oil or the residues on the filter mat using a magnifying glass.

If you find abrasion particles or solid materials on the mat, the hoist gear must be dismantled and inspected by the manufacturer.



Some abrasion particles may appear in the first oil filled. If you notice abrasion particles during the first oil change (after 200 oper. hrs.), first consult **Manitowoc Crane Care** before introducing any specific measures.

8.6.6

Having a partial inspection carried out

Y 3

Only suitably trained specialists should carry out a partial inspection of

- the multiple-disc brake,
- the plug connections between the hydraulic motor and the multiple-disk brake,
- the plug connections between the multiple-disk brake and transmission unit

and be permitted to replace parts with signs of wear.

8.6.7

Having a general inspection carried out

Y 6



When carrying out the general inspection of the hoists, also observe the information contained in *Measures required for winch monitoring*, p. 5 - 21.

The general inspection involves removing the transmission and sending it to the manufacturer to be examined.



For transmissions that have undergone a general overhaul, an oil change must be carried out after 200 and 1,000 operating hours;  *Run-in regulations*, P. 4 - 1.

8.7

Slewing gear

8.7.1



Checking the oil level

W

Spare parts and tools

Designation	Quantity	GROVE part no.
Gasket 10 x 14 Cu DIN 7603	3	00117125

Prerequisites

- The truck crane must be level and in on-road mode;  *Operating manual*.
- The engine must not be running and must be secured against unauthorised use;  P. 2 - 3.

Check the oil level Always check the oil level prior to using the crane.

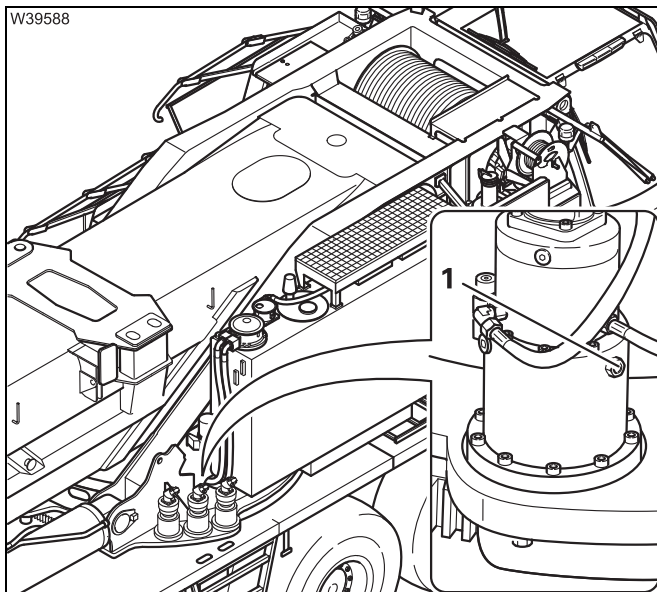

- Check that oil is visible in the sight glass (1).
- Always check the oil level for all the slewing gears.

If the oil level is too low

- Top up the oil;  P. 8 - 52.

8.7.2

Checking for leaks

W

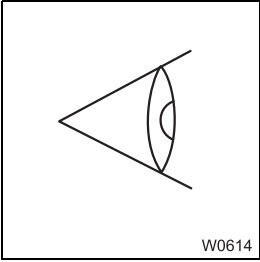

- Pay attention to any unusual running noises from the slewing gears.
- Check the slewing gears and the connections for leaks. If consumables are leaking;  *Checking the oil level*, P. 8 - 49.
- Check that pipes and hoses are tightly connected and undamaged.



If any damage is found, report it to **Manitowoc Crane Care** or an authorised GROVE dealer or your repair crew.

8.7.3

Checking the slewing gear brake

M 6

Prerequisites

- The crane must be rigged with an outrigger span of at least **8.76 x 8.90 m (28.7 x 29.2 ft)** and be level;  *Operating manual*.
- The Mega-Wing-Lift, lattice extension and auxiliary hoist are removed.
- A suitable counterweight combination allowing a steeply raised main boom to be slewed over a range of 360° is rigged according to the *lifting capacity table*.
- Be sure to first obtain detailed information from **Manitowoc Crane Care**.
- The RCL code for the current rigging mode must be entered;  *Operating manual*.
- The current load must not exceed **1 t (2 200 lbs)** – if necessary unreeve the hook block.
- The slewing range 360° around the truck crane must be secured.
- The main boom must be raised to 65° and fully retracted.



Risk of overturning while slewing!

Always set a rigging mode for the slewing range of 360° in accordance with the *lifting capacity table* and enter the corresponding RCL code. Do not override the rated capacity limiter (RCL).



Risk of injury due to swinging hook block!

If a faulty slewing gear brake slips, the superstructure can accidentally, suddenly turn and the hook block can suddenly swing. People standing within the slewing range could be injured.

Secure the slewing range 360°, before you check the slewing gear brake.

Checking

When checking the slewing gear brake you must perform the slewing movement against the slewing gear brake.

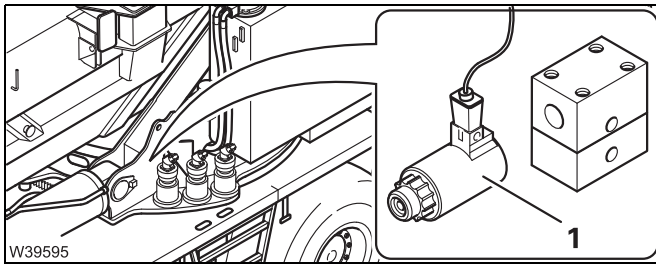

- Switch the engine off.
- Remove the coil (1) from the valve Y 2304. The slewing gear brake will now not be released when the slewing gear is switched on.

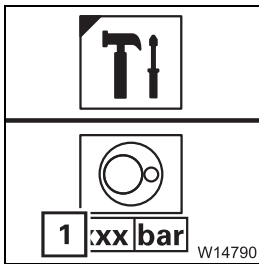

- Start the engine and switch on the slewing gear;  *Operating manual*.
 - Open the *Settings* submenu.
- Display (1) will show the pressure in the slewing gear's hydraulic circuit.

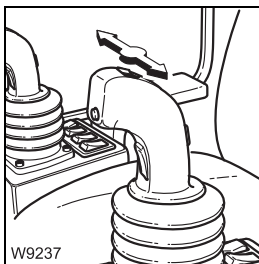

- Move the control lever slowly to the end stop and wait until the pressure in the hydraulic circuit has risen to approx. 200 bar (approx. 2 900 psi).
 - If the superstructure still **does not** slew, the braking force of the slewing gear brake is adequate.
 - If the superstructure does slew, the slewing gear brake is defective and must be repaired immediately by **Manitowoc Crane Care** or an authorised GROVE dealer.

- Switch the slewing gear off and switch the engine off.

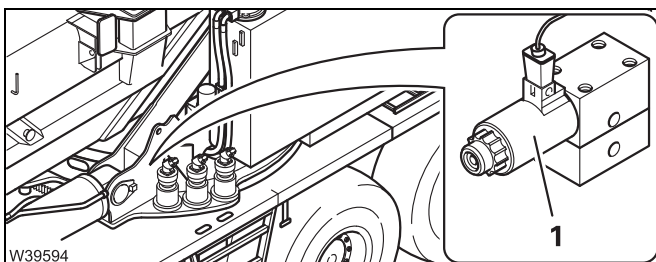

- Fasten the coil (1) to the valve Y 2304 using the nut.
- Start the engine and check the slewing gear for correct operation.

8.7.4

Changing the oil/checking the oil

M 12

- Also adhere to the  *Run-in regulations*, P. 4 - 1.



Oil, spare parts, tools

Gear oil in litres (gal)	Designation to DIN 51502	Specifications Classification	GROVE part no.
0.9 (0.24) for each slewing gear	C - LPF	MIL-L 2105 B API-GL-4/5 Viscosity: SAE 75 W-90 EP ISO - VG 220	02313611 Synthetic oil; do not mix this with mineral-based oils!

Designation	Quantity	GROVE part no.
Gasket 10 x 14 Cu DIN 7603	3	00117125
Gasket 14 x 20 Cu DIN 7603	3	00117132

- Receptacle, approx. 5 l (1.5 gal);  P. 2 - 4.

Prerequisites

- The truck crane must be level and in on-road mode;  *Operating manual*.
- The engine must not be running and must be secured against unauthorised use;  P. 2 - 3.

Changing the oil



Risk of environmental damage due to leaking consumables!

Always let consumables drain into suitable receptacles. Wipe up any consumables that escape.

Store/dispose of consumables and any soaked equipment properly.

Ask about the applicable regulations.

- Always change the oil in all slewing gears.

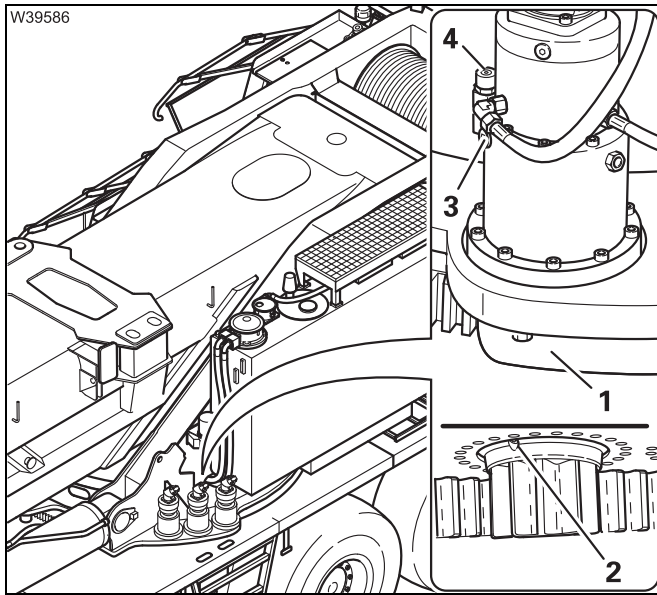

Draining oil

- Remove the plate (1).
- Place a receptacle under the screw (2).
- Unscrew the filter (4) and screws (3) and (2).
- Drain the oil.

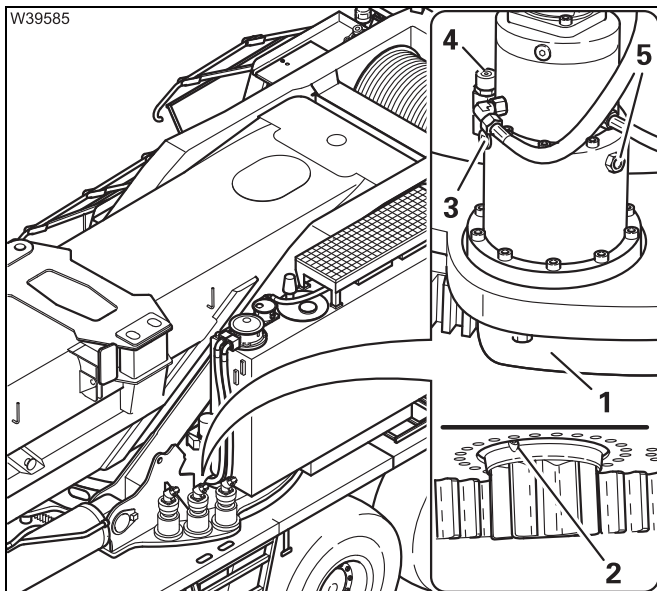

- Replace the gasket and screw the screw (2) back in.

Topping up the oil

- Top up the oil through the filler neck (4) until oil is visible in the sight glass (5).
- Replace the seal and screw in the plug (3) and the filter (4).
- Fasten the plate (1).

Checking the oil

Check the waste oil that was drained from the slewing gears for abrasion particles, or have it tested at a laboratory.

- Pour the waste oil through a clean filter mat.
- Examine the oil or the residues on the filter mat using a magnifying glass.

If you find abrasion particles or solid materials on the mat, the slewing gear transmission must be removed and inspected by the manufacturer.

Blank page

8.8

Slewing bearing

8.8.1

Checking the screws



M 3

- Also adhere to the  *Run-in regulations*, P. 4 - 1.

Tools

- Torque wrench.
- Auxiliary tools for the torque wrench;  P. 8 - 57.

Prerequisites

- The crane must be rigged with an outrigger span of at least **8.76 x 8.90 m (28.7 x 29.2 ft)** and be level;  *Operating manual*.
- A suitable counterweight combination allowing a steeply raised main boom to be slewed over a range of 360° is rigged according to the *lifting capacity table*.
- Be sure to first obtain detailed information from **Manitowoc Crane Care**.
- The Mega-Wing-Lift, lattice extension and auxiliary hoist are removed.
- In addition, the tyres on the 5th and 6th axle lines should be removed to improve the freedom of movement under the slewing bearing.
- The main boom must be fully retracted and raised to 75;  *Operating manual*.
- The current load must not exceed **1 t (2 200 lbs)** – if necessary unreeve the hook block.
- The slewing range 360° around the truck crane must be secured.
- The engine must not be running and must be secured against unauthorised use;  P. 2 - 3.

Safety instructions



Risk of damage to the screws on the slewing bearing!

All screws were tightened at the factory with a certain torque, and this should be checked during maintenance. Only slight tightening of the screws is permissible, if required.

You may **not** slacken the bolts and re-tighten them, or completely unscrew and then reuse them.

If the superstructure has to be removed from the carrier, only a completely **new set of bolts** may be used to reinstall the superstructure. Only **original bolts** manufactured according to the factory specifications may be used.





Danger of the slewing bearing being ripped off!

If while checking you notice very loose, broken or missing screws, then the slewing bearing has been overloaded and is no longer safe to use. During crane operation, the slewing bearing may rip off suddenly and thus cause fatal accidents.

Do not put the truck crane back into operation and have the slewing bearing repaired by **Manitowoc Crane Care**.

Access to the outer ring

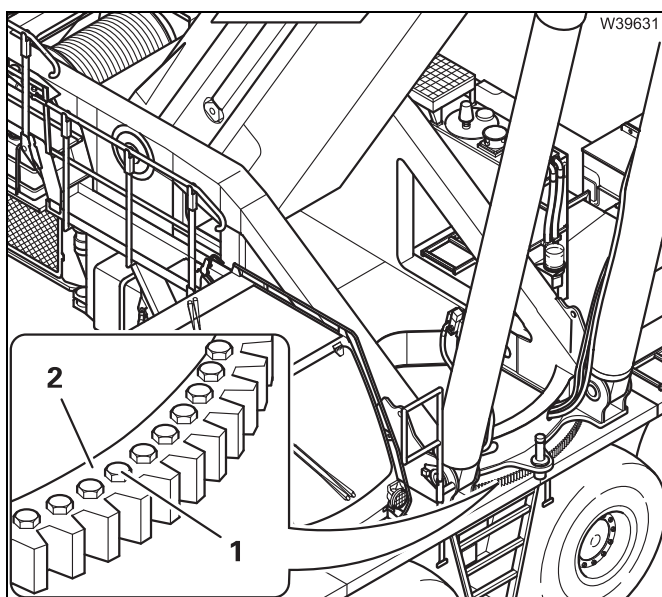

The **outer ring** is attached to the carrier by the bolts (1).

- Check all 96 bolts (1) from **above**.

To do this, you must move the clear area (2) on the turntable round step by step to allow all the bolts (1) to be checked.

Access to the inner ring

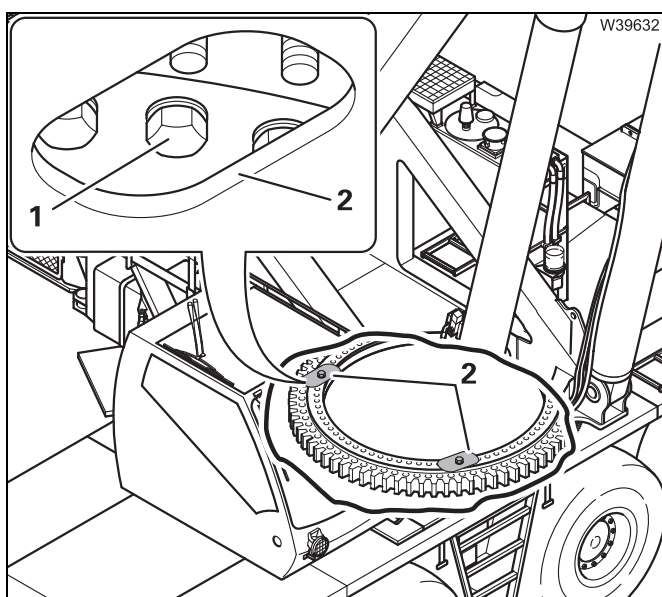

The **inner ring** is attached to the turntable by the bolts (1).

- Check all 96 bolts (1) from **below**.

To do this, you must rotate the turntable gradually to gain access to a pair of bolts (1) opposite one another, through the openings (2) in the carrier.

Selecting the tools

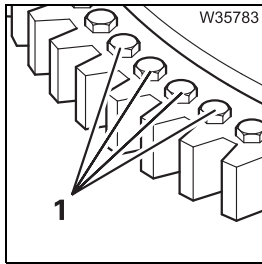

Outer ring

The screw heads (1) are easily accessible for fitting a socket wrench. Therefore, you can use **manual or mechanical torque tools** (electric or hydraulic drivers).

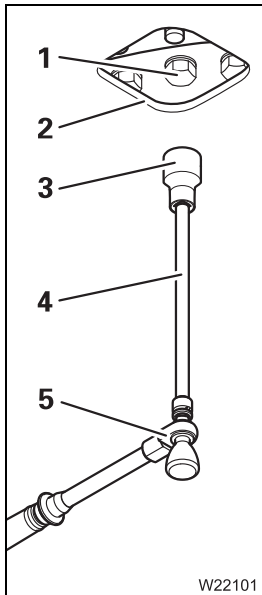

Inner ring

The screw head (1) is accessible only via the opening (2). An extension (4) is required for fitting a socket wrench (3).

A **manual torque tool (5)** is recommended so that it can be tightened gently, and slipping from the screw head (1) is avoided.

Torques

Screw type	GROVE part number	Torque Nm (lbf ft)
Roller slewing bearing Bearing type: RDV, three rows	03319920 Model plate: Inside the inner ring.	
M 30 x 165: 96 pieces on the outer ring	04170757	1,560 (1,150)
M 30 x 195: 96 pieces on the inner ring	04170756	1,560 (1,150)



Checking the outer ring

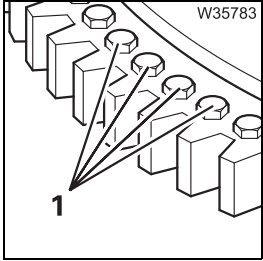

- Divide the checking of the 96 screws into 24 working steps of 4 screws each (1).
Between each of the 24 operation steps you need to rotate the turntable to the next group of 4 screws on the opposite side.
- Switch the engine off after every rotation and secure the truck crane against unauthorised use; ■■■► P. 2 - 3.
- Check the tightness of the first group of 4 adjoining screws (1);
■■■► *Torques*, P. 8 - 57.
- Once they have been checked, mark the screws to avoid subsequent confusion.
- Remove the tool.
- Start the engine and turn the turntable by 180° – the second group on the opposite side is now accessible.
- Switch the engine off.
- Check all other groups in the same way.

Checking the inner ring

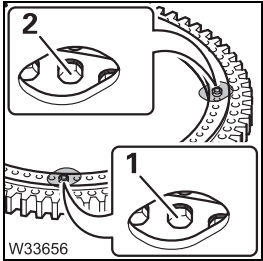

- Divide the checking of the 96 screws into 48 working steps of 2 screws each.
Between each of the 48 operation steps you need to rotate the turntable to the next pair of screws on the opposite side.
- Switch the engine off after every rotation and secure the truck crane against unauthorised use; ■■■► P. 2 - 3.
- Check the tightness of the first pair of screws (1) and (2) on the opposite side; ■■■► *Torques*, P. 8 - 57.
- Mark the screws that have been checked, to avoid confusion later.
- Remove the tool.
- Start the engine and turn the turntable by 90° – the second pair of screws on the opposite side is now accessible.
- Switch the engine off.
- Check all other screws in the group in the same way.

8.8.2

Lubricating the gear teeth

M 6

Grease

Designation	Quantity	GROVE part no.
Adhesive lubricating grease (spray can)	1	00554205



Observe the instructions and safety instructions on the adhesive lubricating grease packaging!

Prerequisites

- The truck crane must be level and on outriggers; *Operating manual*.
- The main boom must be fully raised; *Operating manual*.
- The engine must not be running and must be secured against unauthorised use; P. 2 - 3.

Greasing



Risk of crushing from the gear teeth!

Fingers may be crushed or clothing can be drawn into the open, rotating pinion. For this reason, be sure to remount the plate after lubricating.

A distinction is made between initial lubrication and subsequent lubrications:



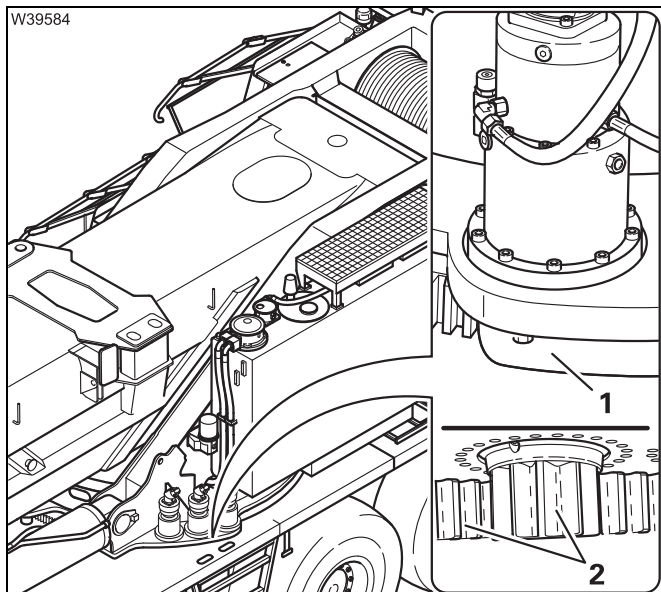

First lubrication

- Remove the plate (1).
- Remove the old grease from all the gear teeth (2).
- Apply a thin layer of new grease to all the gear teeth and allow it to penetrate for about 10 minutes.
- Apply a second, thicker layer of grease and allow it to penetrate for about 30 minutes.
- Attach the plate.

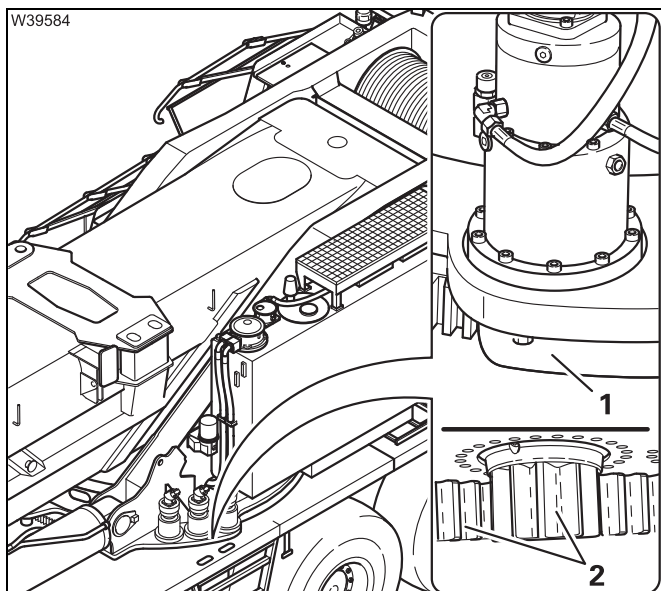

Subsequent lubrication

- Remove the plate (1).
- Apply new grease to all the gear teeth (2).
- Allow it to penetrate for about 30 minutes.
- Attach the plate.

8.8.3

General inspection

M 6

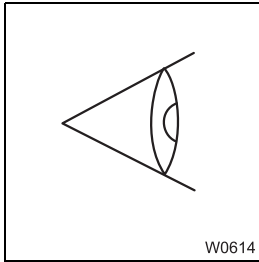

- Pay attention to any unusual running noises from the slewing bearing.
- If unusual noises occur, take a sample of the grease that has escaped. Have **Manitowoc Crane Care** examine the sample for metal residue.
- Check the slewing bearing for damage (e.g. gaskets).

If any damage is found, report it to **Manitowoc Crane Care** or an authorised GROVE dealer or your repair crew.



The maintenance interval specified here must be reduced if the slewing bearing was subjected to heavy blows (falling load, load slipping).

8.8.4

Measuring tilting play

M 6



Reducing the interval

- When after several years of intensive crane operation, half of the value for the maximum permissible tilting play is reached, then you must reduce the maintenance interval.
- Measure the tilting play from then on every three months (**M 3**).

Spare parts and tools

- Dial gauge (precision 0.01 mm (0.00039 in)) with tripod.
- Measurement report from when the truck crane was put into operation;  *Delivery receipt*.

Prerequisites

- The slewing bearing must have been previously checked for tightness;  *Checking the screws*, P. 8 - 55.
- A suitable counterweight combination allowing tilting play to be generated at the slewing bearing by slowly lowering the main boom from a steep position to a flat position is rigged according to the *lifting capacity table*.
- Be sure to obtain detailed information from **Manitowoc Crane Care** before measuring tilting play on the GMK7450.
- The crane must be rigged with an outrigger span of at least **8.76 x 8.90 m (28.7 x 29.2 ft)** and be level;  *Operating manual*.
- The Mega-Wing-Lift, lattice extension and auxiliary hoist are removed.
- The main boom must be fully retracted.
- The current load must not exceed **1 t (2 200 lbs)** – if necessary unreeve the hook block.

Type

The GMK7450 truck crane is equipped with a slewing bearing of the bearing type: RDV, three rows.

Type of slewing bearing	GROVE part number
Roller slewing bearing Bearing type: RDV, three rows	03319920 Model plate: Inside the inner ring.

Measuring tilting play

The base value of the tilting play is determined and documented by **Manitowoc Crane Care** or an authorised GROVE dealer when the ball slewing bearing is put into operation or replaced.

The maximum permissible wear is 1 mm (0.039 in).

This results in the maximum permissible tilting play.

	Base value + max. permissible wear =	max. permissible tilting play
Example:	0.12 mm (0.005 in) + 1 mm (0.039 in)	1.12 mm (0.044 in)

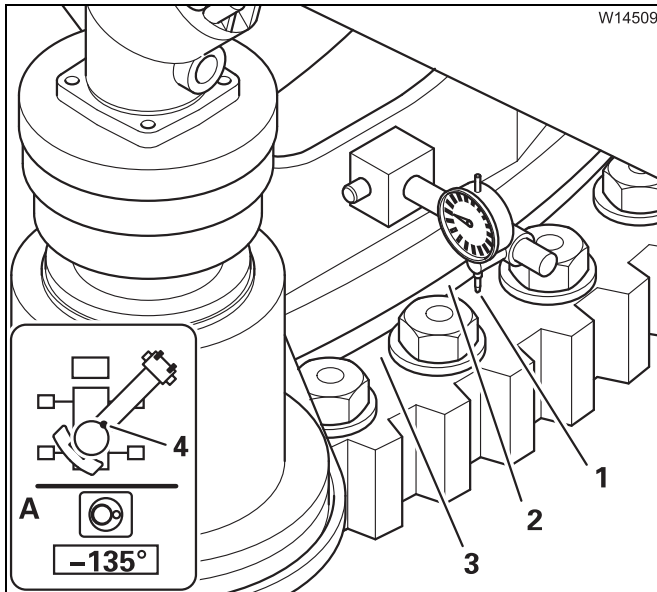

Measuring current tilting play

- Raise the main boom completely and slew to -135° – display (A).
- Fasten a dial gauge on the front on the turntable (4) and place the button (1) on to the lower ring (3) as close as possible to the gasket (2).
- Slowly lower the main boom completely. The hook block may not touch the ground.
- Read off from the dial gauge how far the turntable is inclined and record this value as the current tilting play; \blacktriangleright *Appendix – Tilting play measurement report.*
- Remove the dial gauge.

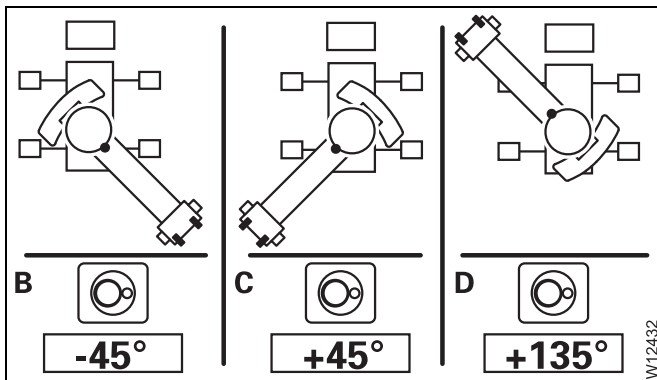

- Repeat the measurement with the slewing angles
 - B** -45°
 - C** $+45^\circ$
 - D** $+135^\circ$

If the **current tilting play** is greater than the **max. permissible tilting play**, you must have the slewing bearing replaced by **Manitowoc Crane Care** or an authorised GROVE dealer.

If the **current tilting play** is half as great as the **max. permissible tilting play**, you must reduce the maintenance interval; \blacktriangleright *Reducing the interval*, P. 8 - 62.

8.8.5

Lubricating the locking of turntable



M 12

Grease, spare parts, tools

Lubricating grease	Designation to DIN 51502	Specifications Classification	GROVE part no.
Grease	KP - 1K - 50	DIN 51825	03233369

- Brush.

Prerequisites

- The truck crane must be level and in on-road mode;  *Operating manual*.
- The engine must not be running and must be secured against unauthorised use;  P. 2 - 3.
- The turntable must be at one of the locking points (0° and 180°).

Greasing

- Familiarize yourself with the operation of the turntable locking and observe the safety instructions;  *Operating manual*.

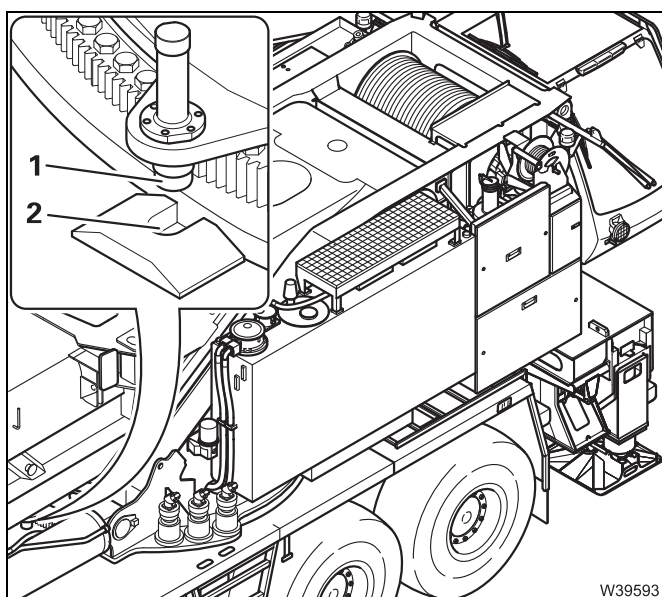

- Grease the lubricating points (1) and (2) with the brush.

8.9 Pump transfer case

8.9.1 General inspection

W

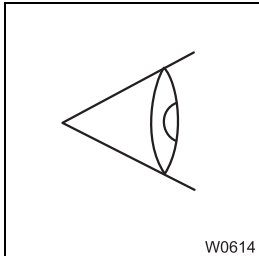

- Pay attention to any unusual running noises from the transmission.
- Check the connections on the transmission for leaks. If consumables are leaking; Check the oil level, P. 8 - 65.

If any damage is found, report it to **Manitowoc Crane Care** or an authorised GROVE-dealer.

8.9.2 Check the oil level

M 1

Spare parts and tools

Designation	Quantity	GROVE part no.
Gasket A21 x 26 x 2	1	03043651

Prerequisites

- The truck crane must be level.
- The engine must not be running and must be secured against unauthorised use; P. 2 - 3.

Check the oil level

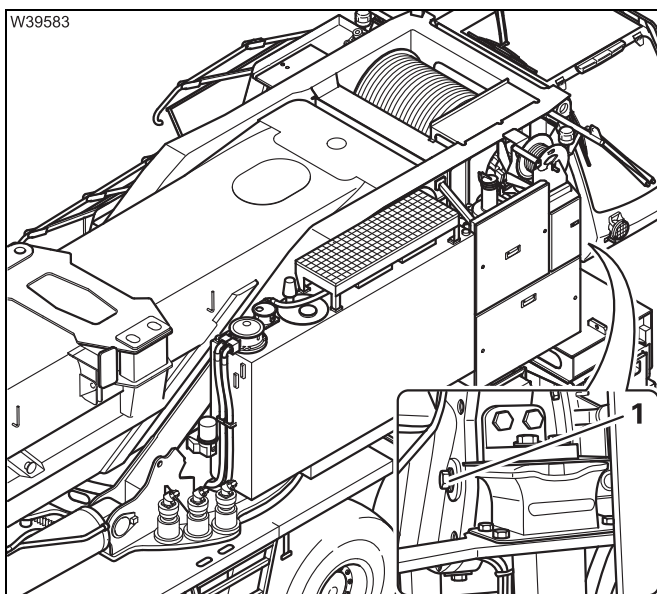

- Remove the drain plug (1).
- Check that the oil reaches the lower edge of the opening.
- Fit a new gasket and tighten the screw (1).

If the oil level is too low

- Fill the oil up to the lower edge of the opening; P. 8 - 66.

8.9.3

Changing the oil

M 12

Oil, spare parts and tools

Gear oil in litres (gal)	Specifications Classification	GROVE part no.
3.8 (1.0)	Aral Degol BG 220 MIL-L 2105 C SAE 90	00554217

Designation	Quantity	GROVE part no.
Gasket A21 x 26 x 2	2	03043651

– Receptacle, approx. 5 l (1.5 gal);  P. 2 - 4.

Prerequisites

- The gear oil is at operating temperature.
- The truck crane must be level.
- The engine must not be running and must be secured against unauthorised use;  P. 2 - 3.

Changing the oil



Risk of scalding from warm gear oil!

When coming into contact with gear oil that has been warmed up through operation, you could get scalded.

Only let the gear oil escape at operating temperature if it has been checked.



Risk of environmental damage due to leaking consumables!

Always let consumables drain into suitable receptacles. Wipe up any consumables that escape.

Store/dispose of consumables and any soaked equipment properly.

Ask about the applicable regulations.

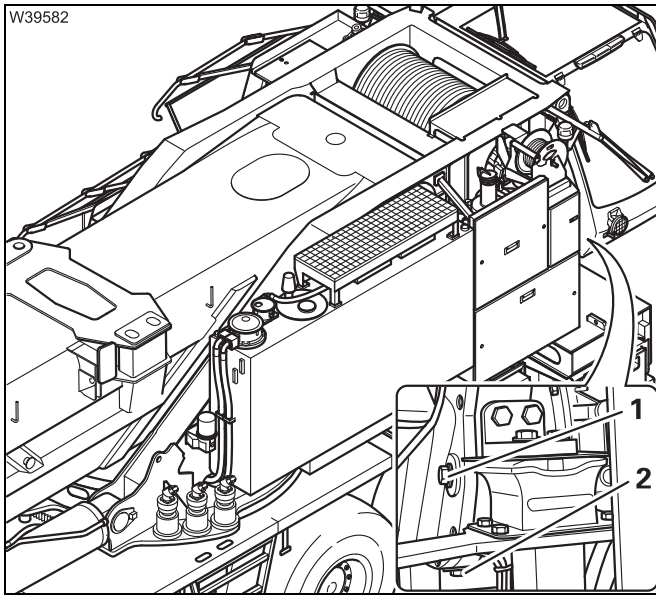

- Place a receptacle under the screw (2).
- Unscrew bolts (1) and (2) and allow the oil to drain.
- Fit a new gasket and tighten the screw (2).
- Fill the oil up to the lower edge of the opening (1).
- Fit a new gasket and tighten the screw (1).

Blank page

8.10

Hydraulic system



Risk of environmental damage due to leaking consumables!

Always let consumables drain into suitable receptacles. Wipe up any consumables that escape.

Store/dispose of consumables and any soaked equipment properly.

Ask about the applicable regulations.

8.10.1

Check the oil level

D

Prerequisites

- The truck crane must be level and in on-road mode; *Operating manual*.
- The telescoping cylinder must be locked in telescopic section 1 *Operating manual*.
- The truck crane must be standing on a level surface.
- The engine must not be running and must be secured against unauthorised use; P. 2 - 3.

Check the oil level



Risk of damage to the hydraulic system!

Cleanliness is imperative when handling hydraulic oil!

Even fresh hydraulic oil must be filtered before it is added to the tank.

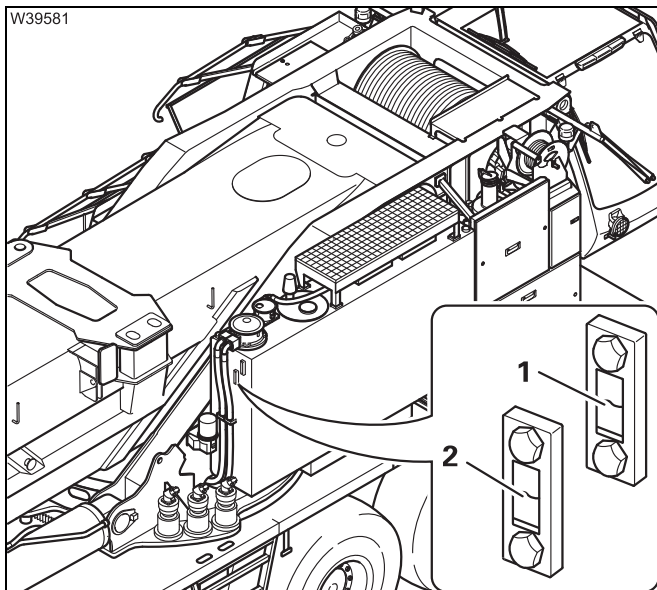

For truck cranes with a Mega-Wing-Lift

- Check whether oil is visible in the middle of the sight glass (1).

For truck cranes without a Mega-Wing-Lift

- Check whether oil is visible in the middle of the sight glass (2).

If the oil level is too low

- Top up with oil; P. 8 - 83.

8.10.2

Checking the hydraulic hoses

W

The inspection work is described in section *Checking the hydraulic hoses*, p. 7 - 88.

8.10.3

Checking the ventilation filter

W

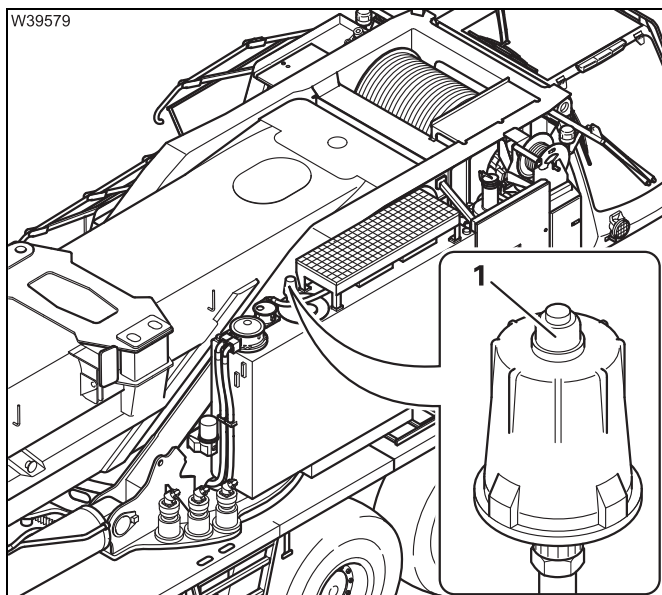

- Check the display (1) on the ventilation filter.

If the indicator is coloured

- Replace the filter; ► P. 8 - 75.

8.10.4

Checking for leaks

W

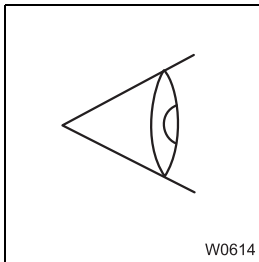

- When the engine is running, carry out a visual inspection for leaks on the hydraulic components (tank, pumps, drives, cylinders, control blocks, valves, pipe and hose lines and connections).
- If leaks are detected, check the oil level and top up if necessary;  *Check the oil level, P. 8 - 69.*



Risk of accidents from hydraulic oil spraying out!

Never tighten any leaking connections when the system is under pressure. Change pipes and hose lines only when the system is depressurised.



Risk of environmental damage due to leaking consumables!

Immediately repair leaks in the hydraulic system or have them repaired to ensure that no hydraulic oil escapes, seeps into the ground or reaches waterways when the crane is used.

After hydraulic components have been changed

- Bleed the hydraulic system;  *Establishing an operational status, P. 8 - 84.*

If damage cannot be rectified immediately or further damage is likely

- Notify **Manitowoc Crane Care** or an authorised GROVE dealer or your repair crew.

8.10.5

Oil filters 1 and 2 – cleaning the magnetic rod

M 3

Spare parts and tools

Designation	Quantity	GROVE part no.
For oil filter 1:		
Filter	1	03325700
Packing set	1	03135853
For oil filter 2:		
Filter	1	03317083
Seal (O-ring)	1	01372280

– Receptacle, approx. 5 l (1.5 gal); ■■■▶ P. 2 - 4.

Prerequisites

- The truck crane must be standing on an even surface.
- The engine must not be running and must be secured against unauthorised use; ■■■▶ P. 2 - 3.



Risk of environmental damage due to leaking consumables!

Always let consumables drain into suitable receptacles. Wipe up any consumables that escape.

Store/dispose of consumables and any soaked equipment properly.

Ask about the applicable regulations.

Cleaning oil filter 1

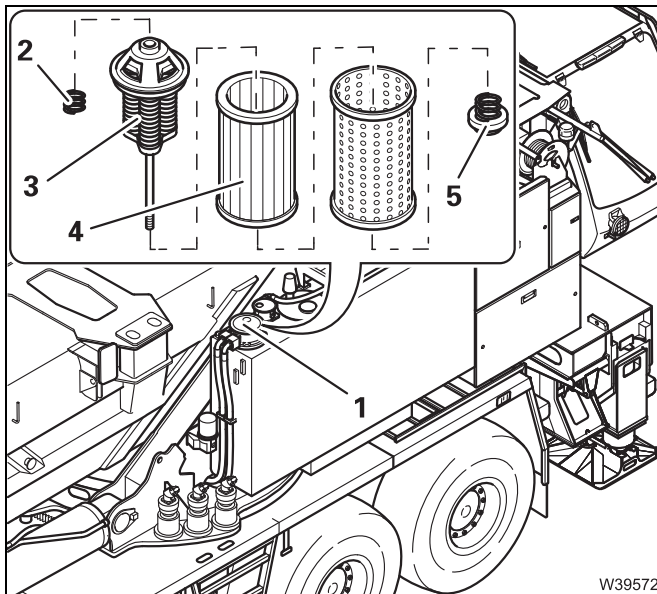

- Take off the cap (1) and pull out the filter.
- Place the filter in a receptacle.
- Remove the spring (2).
- Remove the nut (5).
- Take the magnetic rod (3) out of the filter (4) and clean the magnetic rod.
- Replace any damaged parts, if necessary.



Risk of damage to the hydraulic system

Large amounts of metal particles are a sign of damage in the hydraulic system.

Have the hydraulic system inspected by **Manitowoc Crane Care** or by your qualified repair crew.

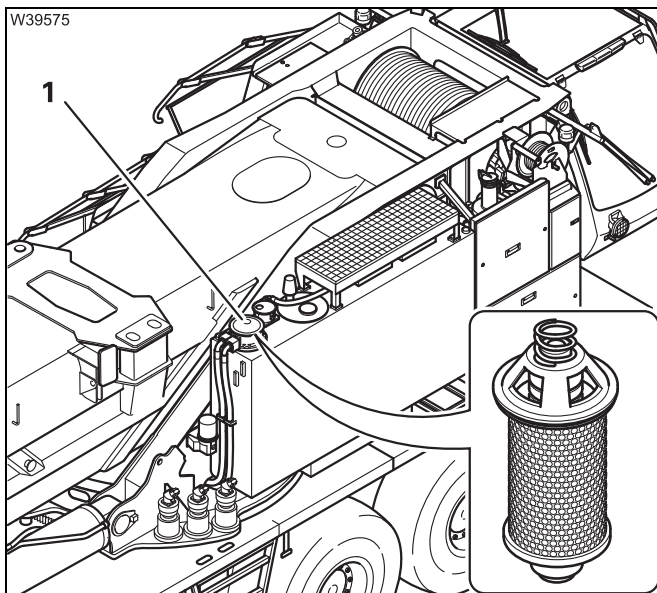

- Replace the gaskets (packing set) if necessary.
- Assemble the filter and insert it.
- Fasten the cover (1).



Cleaning oil filter 2

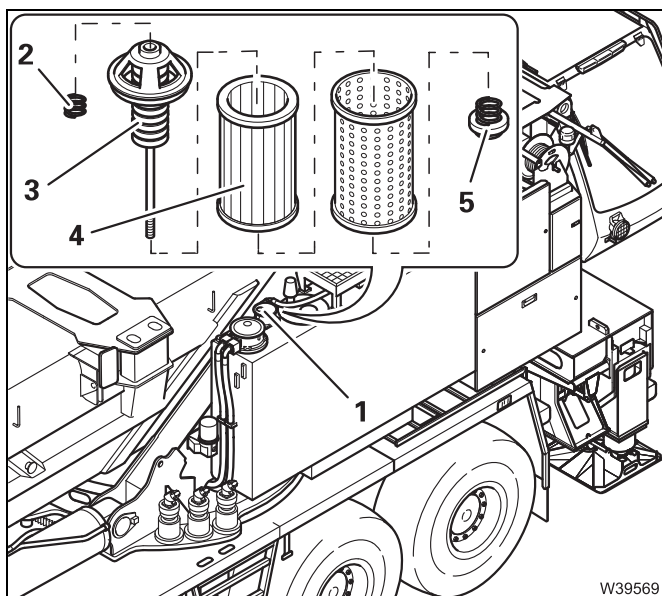

- Take off the cap (1) and pull out the filter.
- Place the filter in a receptacle.
- Remove the spring (2).
- Remove the nut (5).
- Take the magnetic rod (3) out of the filter (4) and clean the magnetic rod.
- Replace any damaged parts, if necessary.



Risk of damage to the hydraulic system

Large amounts of metal particles are a sign of damage in the hydraulic system.

Have the hydraulic system inspected by **Manitowoc Crane Care** or by your qualified repair crew.

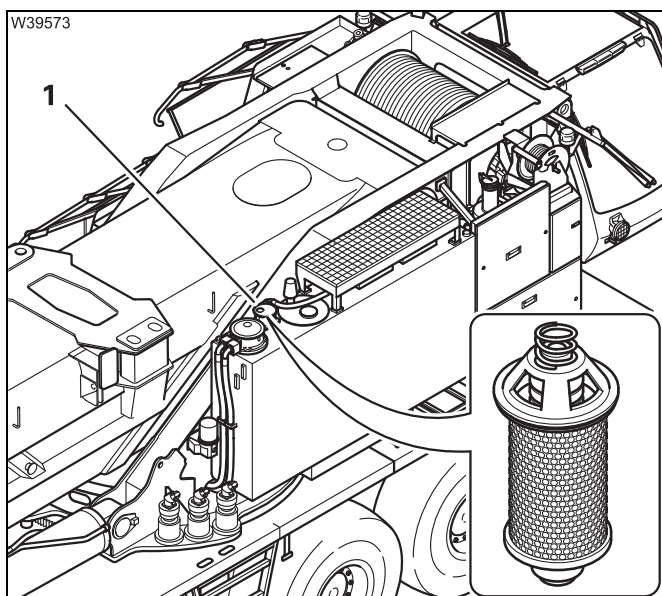

- Replace the gaskets.
- Assemble the filter and insert it.
- Fasten the cover (1).

After cleaning

Start the engine and check the oil filters 1 and 2 for leak-tightness.

8.10.6

Changing the ventilation filter

M 12

Spare parts and tools

Designation	Quantity	GROVE part no.
Filter	1	03319602

Prerequisites

- The engine must not be running and must be secured against unauthorised use;  P. 2 - 3.



Risk of damage to the environment from filter residues!

Store used hydraulic oil filter inserts in suitable receptacles and have them disposed of properly by qualified personnel.

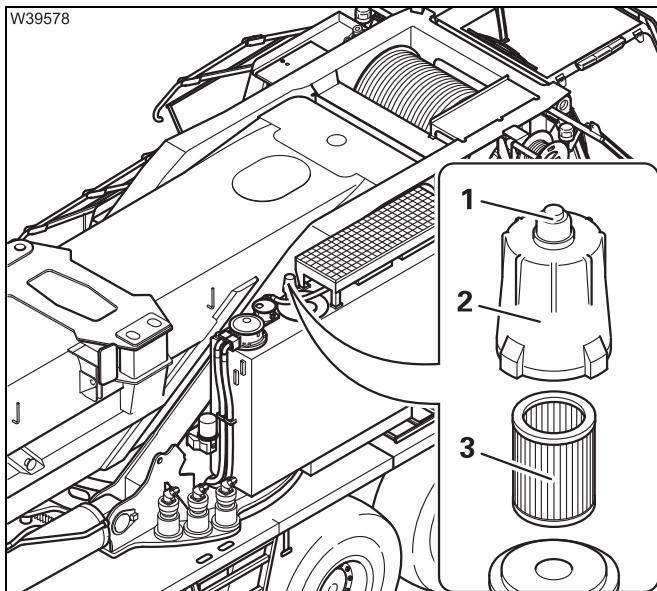

- Remove the cap (2).
- Change the filter (3) and screw on the cap tightly.
- Reset the display by pressing the pin (1) down.

8.10.7

Pressure accumulator – checking the gas pressure

M 12



Risk of accidents due to incorrect inspection!

The gas pressure test must be carried out only by an authorised official inspector of pressure tanks or under his/her supervision or instructions.

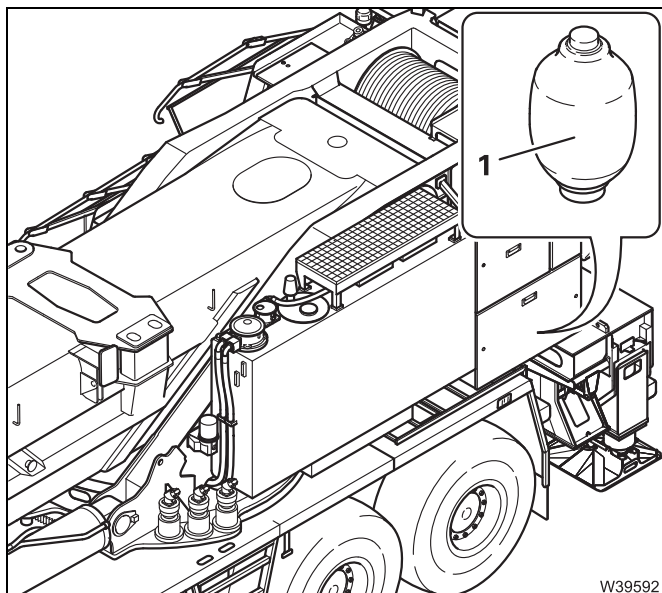

A pressure accumulator is built into the superstructure.

The filling pressure at 20 °C (68 °F) is:

1 Pressure accumulator 180 bar (2610 psi)

- Have the filling pressure checked and if necessary corrected by **Manitowoc Crane Care** or an authorised GROVE dealer.

8.10.8

Taking oil samples

M 12

The oil sample from the superstructure hydraulic system is taken in a way similar to that for the carrier hydraulic system.

Information on taking samples with the hose and on the laboratory analysis;  *Taking oil samples*, P. 7 - 92.

Prerequisites

- The engine must not be running and must be secured against unauthorised use;  P. 2 - 3.

Select the sampling location

To determine the usability of the oil, you must take a sample from the hydraulic system. To do that you must connect the hose with the connecting piece to a gauge port.

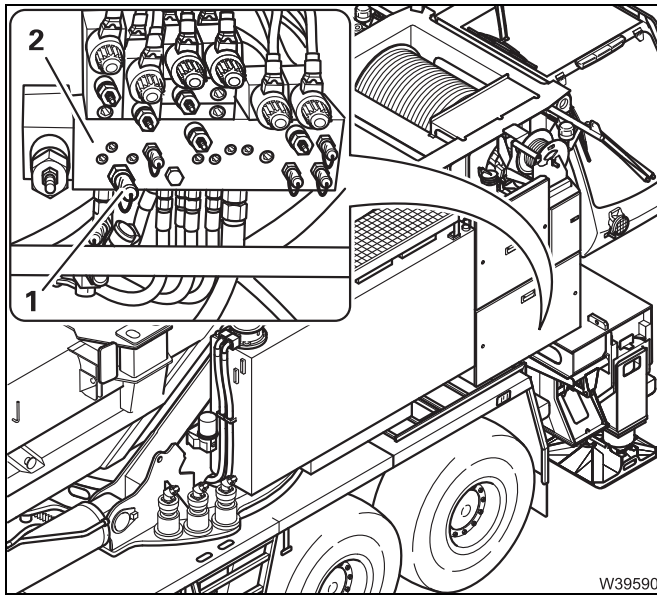

The gauge port (1) is mounted on the control block (2). When a hydraulic function is run, e.g. *tilting the crane cab*, oil can then be taken at the gauge port.

- First consult the *Tilting the crane cab* section of the operating instructions for operating instructions and safety instructions.

Taking oil samples

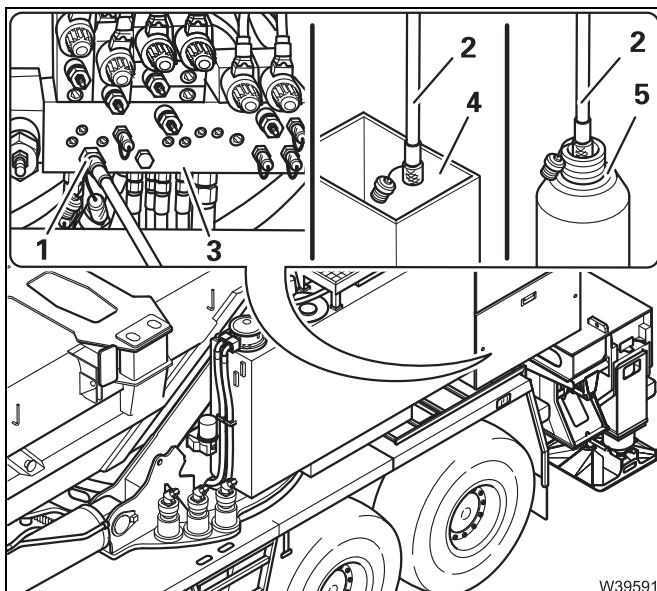

- Clean the gauge port and connect the hose (1) at the port (3); **▣▣▣▣** *Connecting the hose*, P. 7 - 93.
- Put the hose end (2) into the receptacle (4).
- Start the engine.
- Tilt the crane cab.
- Allow 2 litres (0.5 gal) of oil to flow into the receptacle.
- Switch the engine off and put the hose end (2) into the sample container (5).
- Start the engine.
- Tilt the crane cab.
- Allow 0.3 litres (0.08 gal) of oil to flow into the sample container.

- Switch the engine off.
- Remove the hose; **▣▣▣▣** *Disconnecting the hose*, P. 7 - 94.
- Seal the sample container and dispatch it; **▣▣▣▣** *Dispatch the oil sample to the laboratory*, P. 7 - 95.
- Determine the condition of the oil; **▣▣▣▣** *Determining the quality of the oil*, P. 7 - 95.

8.10.9

Changing the hydraulic oil filter

All the oil filters must be replaced when changing the oil.

In the event of a warning message, the red symbols in the *Warning* sub-menu indicate which oil filters you have to change.

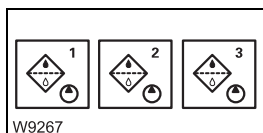

- 1 Red – Change oil filters 1 and 2
- 2 Red – Change oil filters 1 and 2
- 3 Red – Change oil filter 3

In the case of a visual indicator on the filter head of oil filter 3

You must replace oil filter 3 when the indicator bar (1) is in the red area at the left.

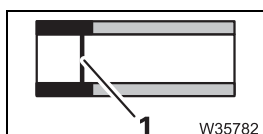

Spare parts and tools

Designation	Quantity	GROVE part no.
For oil filter 1:		
Filter	1	03325700
Packing set	1	03135853
For oil filter 2:		
Filter	1	03317083
Seal (O-ring)	1	01372280
For oil filter 3:		
Filter	1	04257232

– Receptacle, approx. 10 l (3 gal); P. 2 - 4.

Prerequisites

- The truck crane must be level and in on-road mode; *Operating manual*.
- The engine must not be running and must be secured against unauthorised use; P. 2 - 3.



Risk of damage to the environment from filter residues!

Store used hydraulic oil filter inserts in suitable receptacles and have them disposed of properly by qualified personnel.

Change oil filter 1



Risk of environmental damage due to leaking consumables!

Always let consumables drain into suitable receptacles. Wipe up any consumables that escape.

Store/dispose of consumables and any soaked equipment properly.

Ask about the applicable regulations.

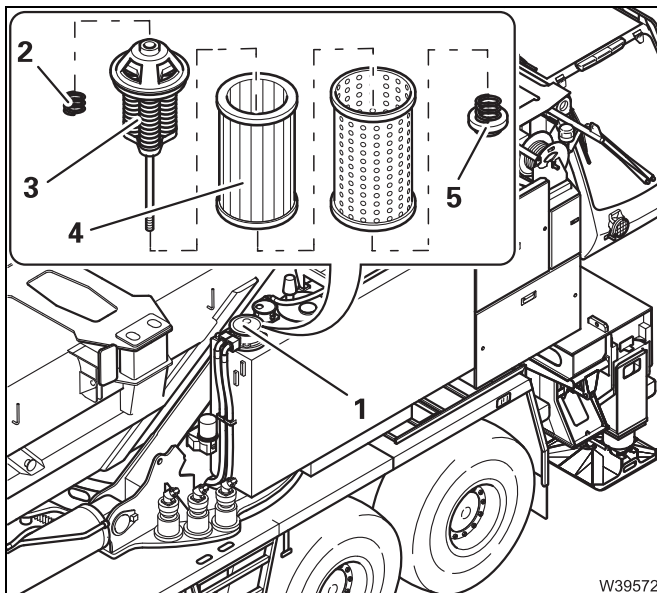

- Take off the cap (1) and pull out the filter.
- Place the filter in a receptacle.
- Remove the spring (2).
- Remove the nut (5).
- Remove the magnetic rod (3) and filter (4) from the filter cage.
- Clean the magnetic rod (3) and filter cage.
- Insert a new filter (4) into the filter cage.
- Replace any damaged parts, if necessary.

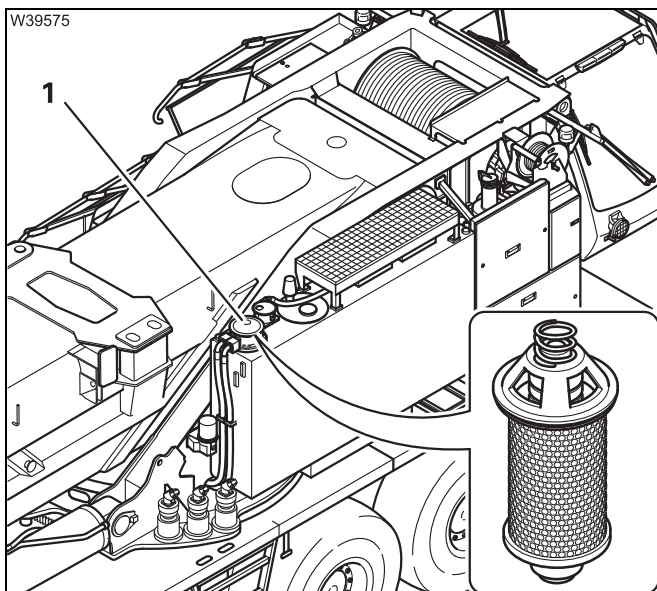

- Replace the gaskets (packing set) if necessary.
- Assemble the filter and insert it.
- Fasten the cover (1).



Change oil filter 2

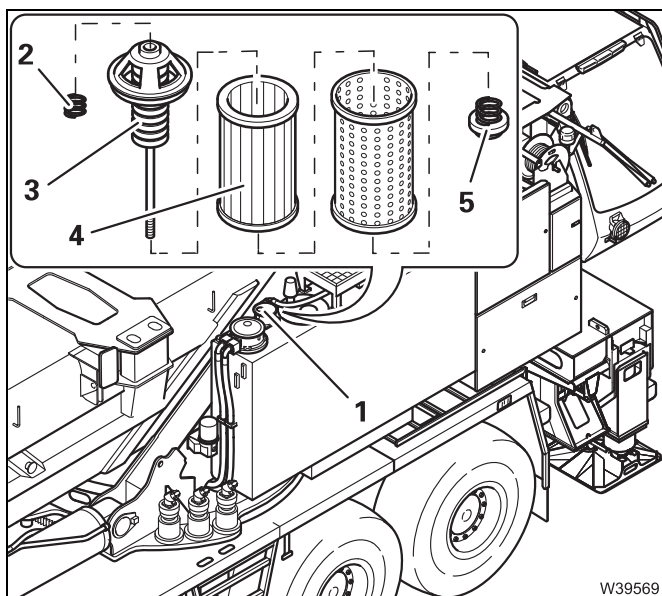

- Take off the cap (1) and pull out the filter.
- Place the filter in a receptacle.
- Remove the spring (2).
- Remove the nut (5).
- Remove the magnetic rod (3) and filter (4) from the filter cage.
- Clean the magnetic rod (3) and filter cage.
- Insert a new filter (4) into the filter cage.
- Replace any damaged parts, if necessary.

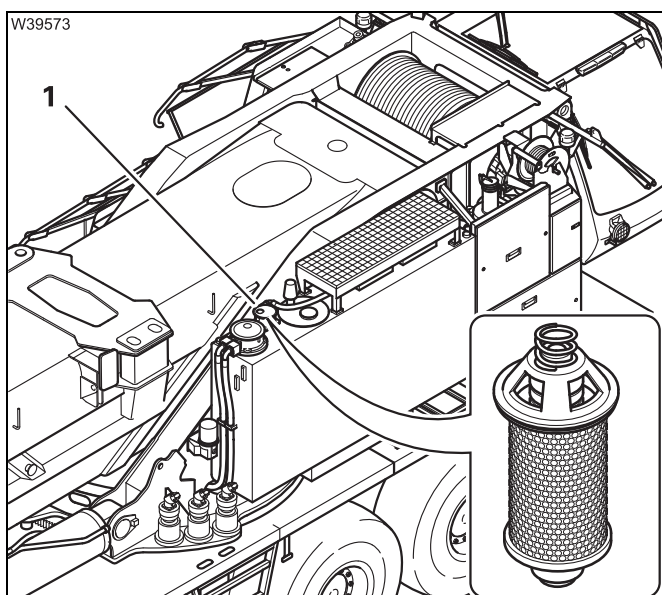

- Replace the gaskets.
- Assemble the filter and insert it.
- Fasten the cover (1).

Change oil filter 3

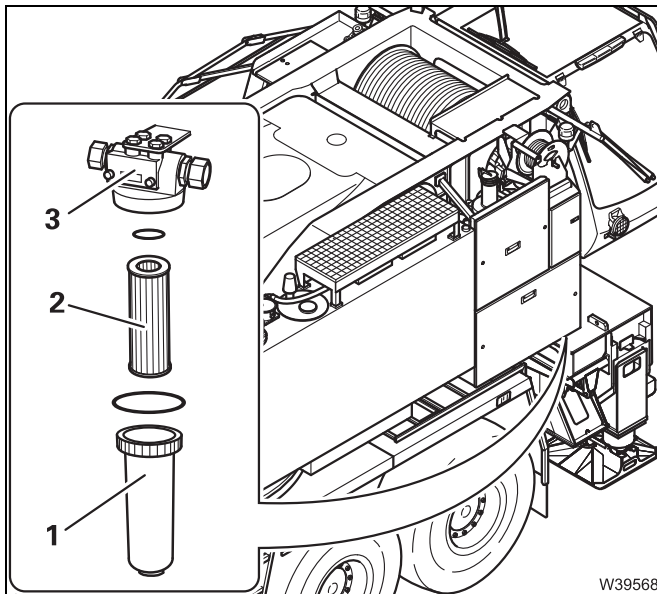

- Release the receptacle (1) at the hexagon head.
- Change the filter (2).
- Replace the gaskets.
- Fill the receptacle with clean oil and tighten it up.
- Check the visual display (3); P. 8 - 78.

After changing the filter



Risk of damage to the hydraulic pumps!

The engine may only be started if the valve in the suction line of the hydraulic pumps is open and there is enough hydraulic oil in the hydraulic oil tank!

- Check the valves on the hydraulic oil tank. Open the valves, if necessary; P. 8 - 84.
- Check the oil level. Top up the oil, if necessary; P. 8 - 83.
- To bleed the system, start the engine and let it idle for 3 minutes.
- Check that none of the oil filters is leaking.
- Check the visual indicator on the oil filter 3; P. 8 - 78.

8.10.10 Changing the hydraulic oil

The oil only needs to be changed if the laboratory analysis results indicate this; ■■■► *Taking oil samples*, P. 8 - 76.

Oil, spare parts, tools

Hydraulic oil in litres (gal)	Designation to DIN 51502	Specifications Classification	GROVE part no.
1,780 (470) (With MWL)	HVLP	DIN 51524-3 Viscosity: ISO-VG 32	04162158 Castrol Hyspin AWH-M 32

Designation	Quantity	GROVE part no.
Cover gasket 140 / 90 x 3	1	02313899

- Connecting piece and hose (tool box); ■■■► P. 7 - 98.
- One or more receptacles, approx. 1,800 l (475 gal); ■■■► P. 2 - 4.

Prerequisites

- The truck crane must be level and in on-road mode; ■■■► *Operating manual*.
- The engine must not be running and must be secured against unauthorised use; ■■■► P. 2 - 3.
- The oil filters must be removed; ■■■► *Changing the hydraulic oil filter*, P. 8 - 78.

Closing the valves



Risk of damage to the hydraulic pumps!

Be sure to secure the engine against unauthorised use.

If the engine is started while the valves in the suction lines are closed, the hydraulic pumps will be damaged!

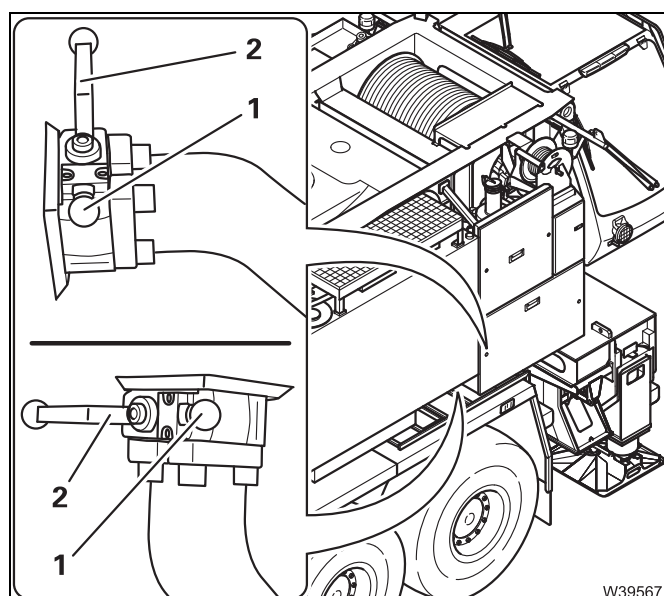

- Pull out the locking bolt (1).
- Close the valves – lever (2) at right angles to the line.
- Insert the locking bolt (1).

W39567

Draining oil



Risk of environmental damage due to leaking consumables!

Use the supplied connecting piece and hose and a receptacle with sufficient capacity to drain the hydraulic oil.

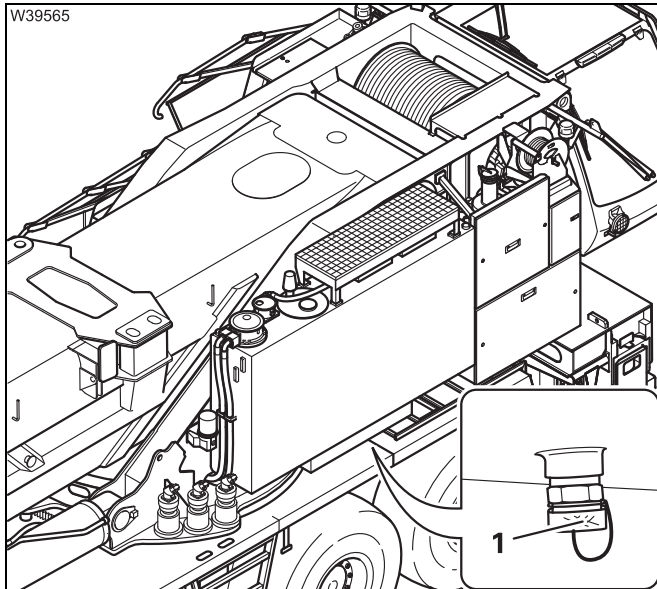

- Place a receptacle underneath the valve.
- Screw the connecting piece and hose on to the valve (1) and drain the oil; Handling the valves, P. 7 - 98.
- Change the filters; P. 8 - 78.

Topping up the oil



Risk of damage to the hydraulic system!

Cleanliness is of the utmost importance when handling hydraulic oil. Even fresh hydraulic oil must be filtered before it is added to the tank.

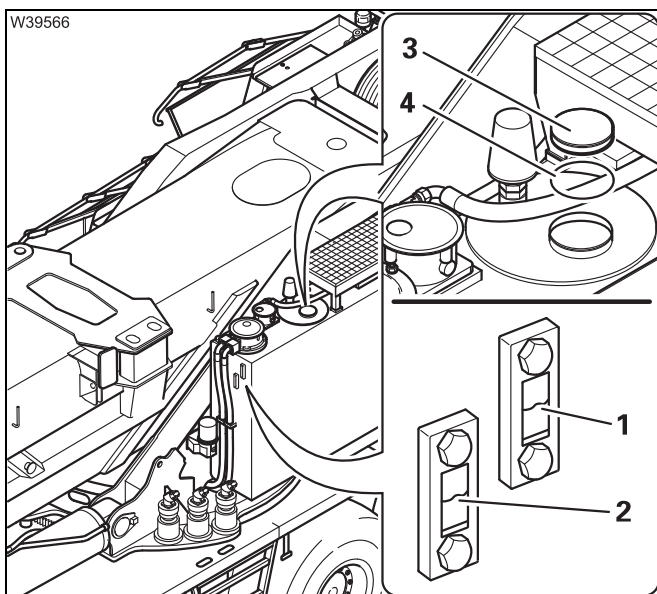

- Remove the cap (3).

For truck cranes with a Mega-Wing-Lift

- Add the new oil through a strainer until it reaches the middle of the inspection glass (1).

For truck cranes without a Mega-Wing-Lift

- Add the new oil through a strainer until it reaches the middle of the inspection glass (2).
- Replace the gasket (4) if necessary and fasten the cap (3).



Establishing an operational status

After having changed the oil filters and topping up the oil, you must re-establish the operating conditions.



Risk of damage to the hydraulic pumps!

Open the valves prior to starting the engine.
This prevents damage to the hydraulic pumps.

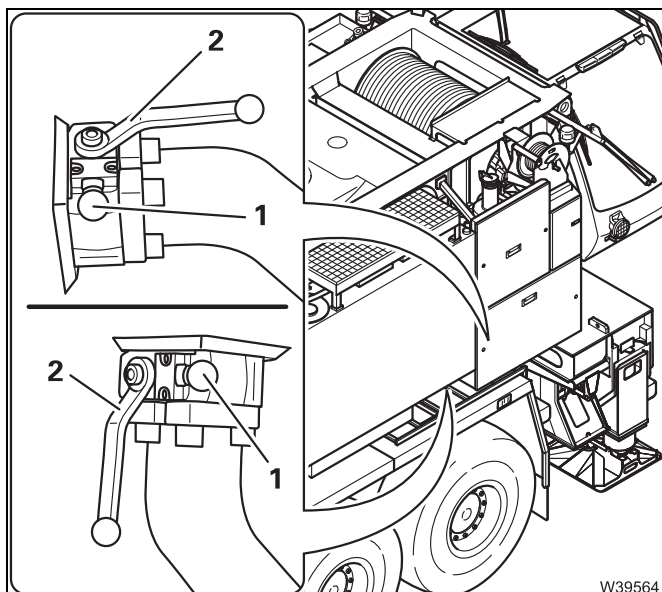

Opening the valves

- Pull out the locking bolt (1).
- Open the valves – lever (2) parallel with the line.
- Insert the locking bolt (1).

- Start the engine.
- Carry out all hydraulic functions several times to remove any air in the system.
- Check that none of the oil filters is leaking.
- Check the oil level through the sight glass on the hydraulic oil tank. Top up oil if necessary; ►► P. 8 - 83.

8.11 Main boom

8.11.1 Grease the piston rod of the derricking cylinder

M 1

Grease, spare parts and tools

Designation	GROVE part no.
Lubricant RHUS 2 AF; 1 kg (Apply the grease with a brush)	03325215
or	
Spray on Berulub; 0.5 litres (spray-on spray)	01929824

– Brush.



Risk of damage to the derricking cylinder's gasket due to rust!

Ensure that the uncovered end of the piston rod is always kept covered with a layer of grease. In this way you can avoid rust which damages the gasket in the derricking cylinder head when fully lowered.

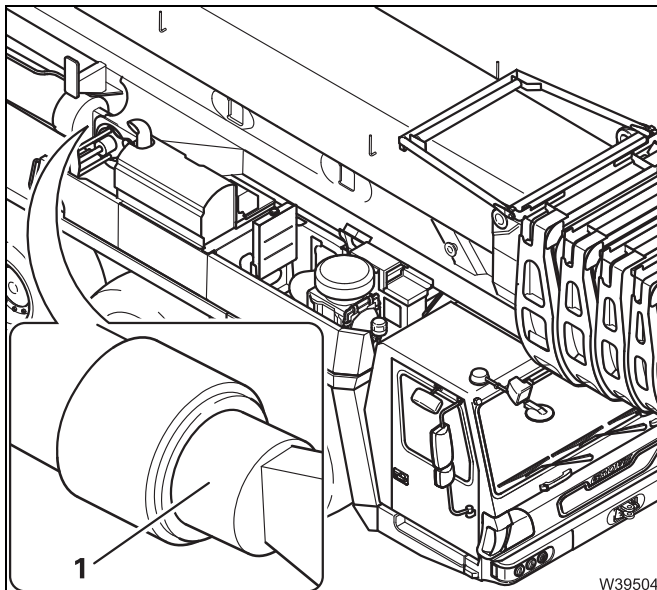

- Clean the uncovered end (1) of the piston rod by removing old grease, dirt particles and rust.
- Grease the uncovered end, making sure the grease coating is evenly distributed.
- Repeat this procedure on the second derricking cylinder.

After every high-pressure cleaning operation on the truck crane

- Grease the piston rod.



You can hinder the formation of rust if you turn the main boom to the side between maintenance intervals and completely lower it.

8.11.2

Lubricating the locking pins

M 3

Reducing the interval

Under difficult operating conditions – at extremely sandy or rainy locations – you must lubricate them more frequently.

Grease, spare parts, tools

Lubricating grease	Designation to DIN 51502	Specifications Classification	GROVE part no.
Spray	Spray on Berulub; 0.5 litres (spray-on spray)		01929824

Prerequisites

- The truck crane is supported on an outrigger span of **8.76 m x 6.10 m (28.7 ft x 20.0 ft)** and has been rigged with at least a **60 t** counterweight **or**
- the truck crane is supported on an outrigger span of **8.76 m x 8.90 m (28.7 ft x 29.2 ft)** and has been rigged with at least a **40 t** counterweight.
- The truck crane must be level.
- The hook block must be unreeved.
- The main boom must be completely retracted and lowered into horizontal position.

Information



Risk of accidents from slipping off the main boom!

There is grease residue on the telescopic sections. For this reason, you must not walk on the main boom.

Use the ladder provided with your crane!



Risk of overturning when telescoping if the RCL is overridden!

You must override the rated capacity limiter (RCL) in order to telescope a second telescopic section in a horizontal position.

When the RCL is overridden, only carry out a telescopic extension as far as specified here. In this way, you avoid overturning the truck crane – even when it is rigged with a 60 t counterweight and the superstructure is rotated to the rear.

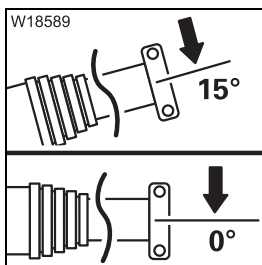

If the main boom has been telescoped **several times**, the telescoping mechanism and derricking gear can be so heavily loaded that the main boom can be neither telescoped nor derricked. Therefore note the following instructions:

- Before retracting the boom, raise it to approximately 15°.
- Do not lower the main boom below 0°.

Telescopic section I

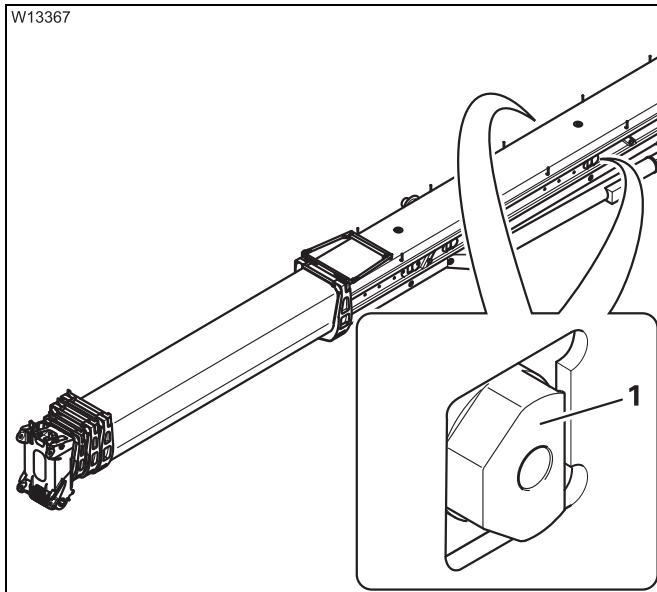

- Mechanically lock the telescopic section I at a fixed length of 44%.

You can now access the locking pins (1) from the outside.

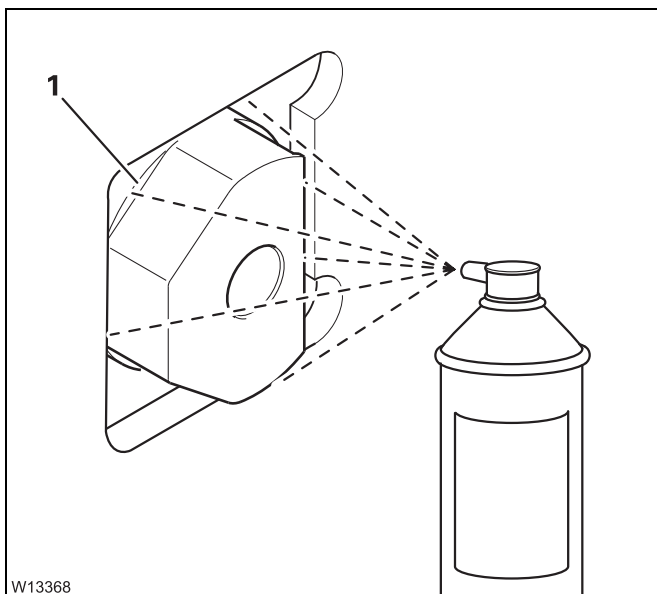

Lubricating the locking pins

- Spray oil around the gap (1).
- Lubricate the locking pins on the opposite side in the same way.
- Distribute the oil by locking and unlocking the telescopic section several times.



Telescopic section II -IV

- Retract all telescopic sections.
- Enter the RCL rigging code for the current rigging mode of the truck crane.



Risk of overturning when telescoping if the RCL is overridden!

You must override the rated capacity limiter (RCL) in order to telescope a second telescopic section in a horizontal position.

When the RCL is overridden, only carry out a telescopic extension as far as specified here. In this way, you avoid overturning the truck crane – even when it is rigged with a 60 t counterweight and the superstructure is rotated to the rear.

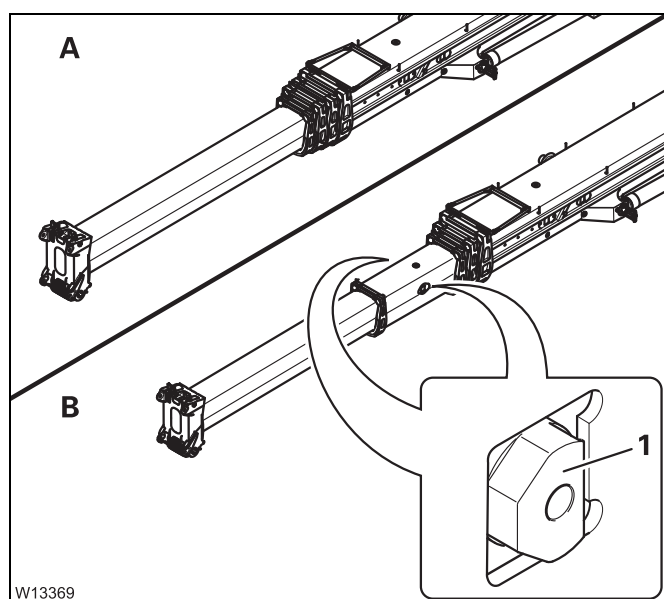

The procedure is the same for the telescopic sections **II -IV**.

- **(A)** – Mechanically lock the telescopic section to the 100% fixed length, e.g. telescopic section **IV**.
- **(B)** – Override the RCL.
- Extend the next smallest telescopic section approx. 1.50 m (5 ft), e.g. telescopic section **III**.
- Lubricate the locking pins **(1)** in the same way as for telescopic section **I**;  P. 8 - 87.
- Retract all telescopic sections.

W13369

8.11.3

Lubricating the telescopic slide faces

M 3

Reducing the interval

Under difficult operating conditions – at extremely sandy or rainy locations – you must lubricate them more frequently.

Grease, spare parts, tools

Designation	GROVE part no.
Slide paste for the telescopic slide faces: PAL1, 25 kg bucket	02314698

- A grease gun for the grease nipples on the upper telescopic slide faces.
- A brush or roller for the outer, upper and lower telescopic slide faces.



Manitowoc Crane Group Germany GmbH recommends using pneumatic grease spray guns for more effective lubrication of the telescopic slide faces:

Designation	GROVE part no.
Grease spray gun, complete: Mobile, external compressed air connection required	03325445
Manual grease spray gun for cartridge: Via the tyre inflator connection on the truck crane	03329027
25 m hose for manual grease spray gun:	03329072
Slide paste for the telescopic slide faces: PAL1, 400 ml cartridge, refillable	03329071

Prerequisites

- The truck crane is supported on an outrigger span of **8.76 m x 6.10 m (28.7 ft x 20.0 ft)** and has been rigged with at least a **60 t** counterweight **or**
- The truck crane is supported on an outrigger span of **8.76 m x 8.90 m (28.7 ft x 29.2 ft)** and has been rigged with at least a **40 t** counterweight.
- The truck crane must be level.
- The hook block must be unreeved.
- The main boom must be completely retracted and lowered into horizontal position.
- The RCL code for the current rigging mode must be entered.



Safety instructions



Risk of accidents from slipping off the main boom!

There is grease residue on the telescopic sections. For this reason, you must not walk on the main boom.

Use the ladder provided with your crane!



Risk of overturning when telescoping if the RCL is overridden!

You must override the rated capacity limiter (RCL) in order to telescope a second telescopic section in a horizontal position.

When the RCL is overridden, only carry out a telescopic extension as far as specified here. In this way, you avoid overturning the truck crane – even when it is rigged with a 60 t counterweight and the superstructure is rotated to the rear.

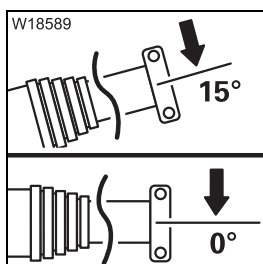

If the main boom has been telescoped **several times**, the telescoping mechanism and derricking gear can be so heavily loaded that the main boom can be neither telescoped nor derricked. Therefore note the following instructions:

- Before retracting the boom, raise it to approximately 15°.
- Do not lower the main boom below 0°.

**Location of the
lubricating points**

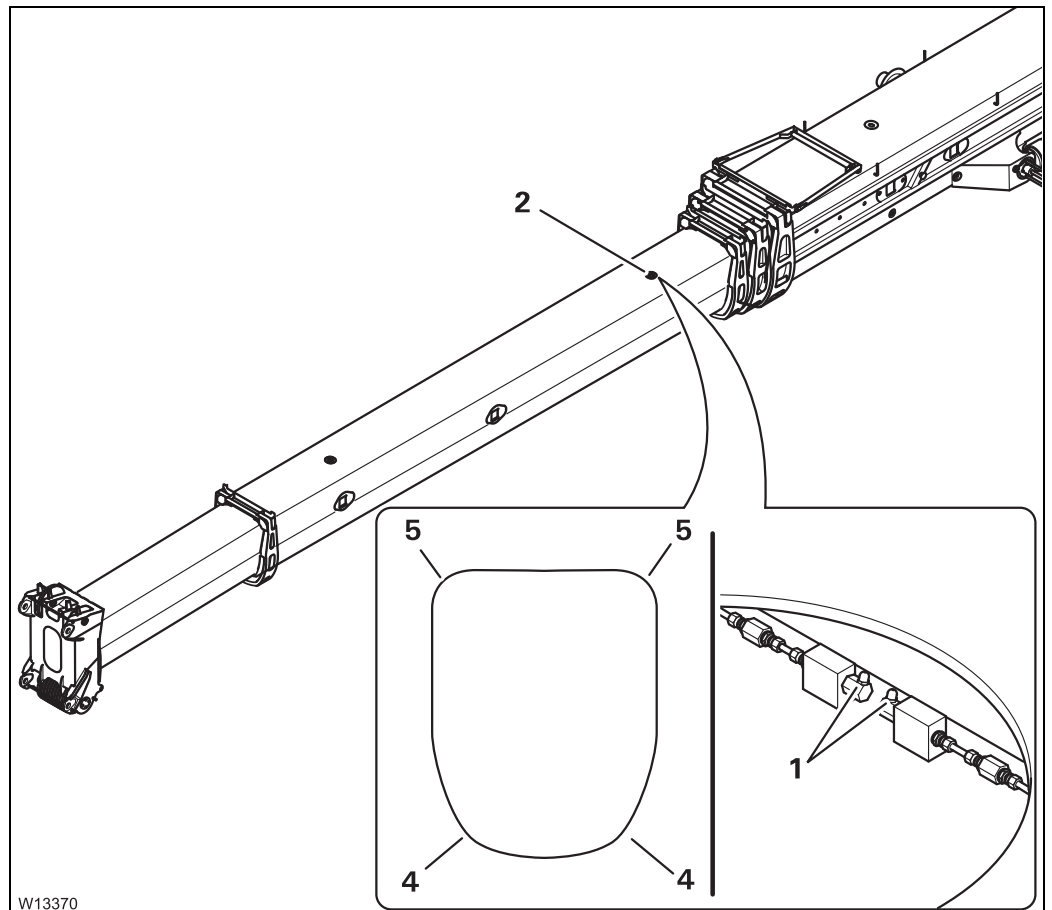

The diagram shows the telescoping for the lubrication of telescopic section **IV**. There are four slide faces on the edges of the telescopic sections.

- The two outer lower slide faces (**4**) and the outer upper slide faces (**5**) are lubricated from the outside in the extended state.
- The two upper slide faces (**5**) are lubricated via the lubricating nipple (**1**). The lubricating nipples (**1**) can be reached through the bore holes (**2**) in the telescopic sections located above them.



Telescopic section IV

- Retract all telescopic sections.
- Enter the RCL rigging code for the current rigging mode of the truck crane.
- Telescope telescopic section **IV** to the first locking position (44%) and lock it.
- Override the RCL,
To do this, turn the Override key-operated switch to the right.
- Extend telescopic section **III** to approx. 88% until the lubricating hole for telescopic section **IV** can be reached in the top chord.
- Use the grease gun (PAL1) to lubricate the upper slide faces at the lubricating nipples (1) on both sides.
- Fully retract telescopic section **III**.
- Turn off the RCL override.
- Fully extend telescopic section **IV**.
- Use a brush or a roller (PAL1) to lubricate the outer upper and lower slide faces of telescopic section **IV**.
- Extend and retract telescopic section **IV** again so that the grease is distributed uniformly on the telescopic slide faces.
- Retract telescopic section **IV**.

Telescopic section III

- Retract all telescopic sections.
- Enter the RCL rigging code for the current rigging mode of the truck crane.
- Telescope telescopic section **III** to the first locking position (44%) and lock it.
- Override the RCL,
To do this, turn the Override key-operated switch to the right.
- Extend telescopic section **II** to approx. 88% until the lubricating hole for telescopic section **III** can be reached in the top chord.
- Use the grease gun (PAL1) to lubricate the upper slide faces at the lubricating nipples (1) on both sides.
- Fully retract telescopic section **II**.
- Turn off the RCL override.
- Fully extend telescopic section **III**.
- Use a brush or a roller (PAL1) to lubricate the outer upper and lower slide faces of telescopic section **III**.
- Extend and retract telescopic section **III** again so that the grease is distributed uniformly on the telescopic slide faces.
- Fully retract telescopic section **III**.

Telescopic section II

- Retract all telescopic sections.
- Enter the RCL rigging code for the current rigging mode of the truck crane.
- Telescope telescopic section **II** to the first locking position (44%) and lock it.
- Override the RCL,
To do this, turn the Override key-operated switch to the right.
- Extend telescopic section **I** to approx. 88% until the lubricating hole for telescopic section **II** can be reached in the top chord.
- Use the grease gun (PAL1) to lubricate the upper slide faces at the lubricating nipples (**1**) on both sides.
- Fully retract telescopic section **I**.
- Turn off the RCL override.
- Fully extend telescopic section **II**.
- Use a brush or a roller (PAL1) to lubricate the outer upper and lower slide faces of telescopic section **II**.
- Extend and retract telescopic section **II** again so that the grease is distributed uniformly on the telescopic slide faces.
- Retract telescopic section **II**.

Telescopic section I

- Retract all telescopic sections.
- Enter the RCL rigging code for the current rigging mode of the truck crane.
- Telescope telescopic section **I** to 100% and lock it.
You can now reach the lubricating nipples (**1**) via the front lubricating hole in the top chord of the basic section.
- Use the grease gun (PAL1) to lubricate the upper slide faces at the lubricating nipples (**1**) on both sides.
- Use a brush or a roller (PAL1) to lubricate the outer upper and lower slide faces of telescopic section **I**.
- Retract and extend telescopic section **I** again so that the grease is distributed uniformly on the telescope slide faces.
- Retract telescopic section **I**.



Before driving the truck crane

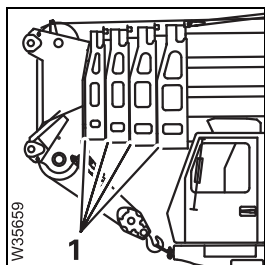

Fully retracting all telescopic sections of the main boom after greasing may result in excess lubricant paste emerging at the collar (1).

- Remove any excess lubricant paste from the collar (1).
This is to prevent any lumps dropping off on to the windscreen and suddenly obstructing the view when driving.

8.11.4

Checking the sheaves

M 3

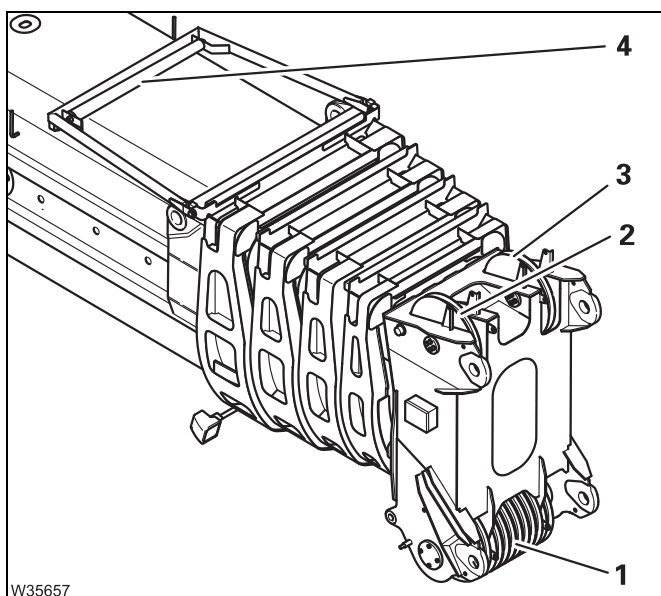

- Check all the sheaves (1) to (4) on the main boom head and on the bracket for damage, wear, mobility and for excessive dirt.

Have damaged, worn, stiff or extremely soiled sheaves replaced by **Manitowoc Crane Care** or an authorised GROVE dealer or your repair crew.

8.11.5

Checking the locking system

M 12



Risk of accidents if maintenance work is not carried out!

Have the maintenance work on the main boom locking system performed regularly by **Manitowoc Crane Care** or an authorised GROVE dealer.

This prevents the complete unlocking of a telescopic section in Emergency operation/Emergency program mode, which could cause serious accidents and damage to the truck crane.

- Have the main boom locking system checked regularly by **Manitowoc Crane Care** or an authorised GROVE dealer.

Blank page

8.12 Hoist ropes

8.12.1 Checking the winding

D



Risk of accidents due to rotating rope drum!

Keep away from the rope drum while it is turning.

This will prevent your limbs from being drawn in and getting crushed.

Prerequisites

- The hoist mirrors must be folded out; *Operating manual*.
- Camera monitoring (additional equipment) of the hoists from the crane cab must be switched on *Operating manual*.
- One hook block must be reeved; *Operating manual*.
- The main boom must be raised to about 30°; *Operating manual*.
- The engine must be started.

Checking

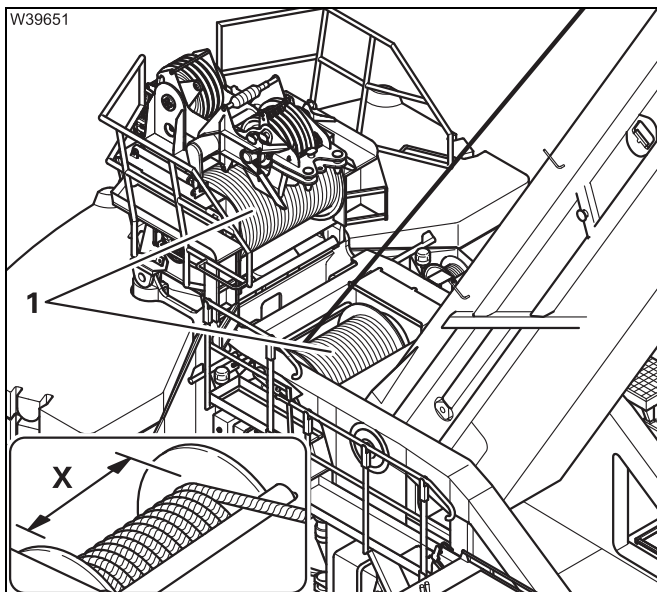

Always check the entire length of the winding of the ropes (1).

- Slowly perform the *Lower* movement until the rope has moved over the complete width (X) of the rope drum.
 - The rope must be evenly wound.
 - The rope turns on the drum must be evenly spaced at a distance of 0 to 2 mm (0 to 0.08 in).
 - The cross-over points must be at an angle of approx. 180° to each other.



The ropes of the top layer lie over the ropes of the bottom layer at the cross-over points.

8.12.2

Checking the hoist ropes

W

Spare parts and tools

- Torque wrench for 80 Nm (59 lbf ft).

Prerequisites

- Establish a rigging mode in accordance with the *Lifting capacity table* and enter the RCL; ■■■► *Operating manual*.
- A hook block is reeved (reeve for the main hoist has six lines, and 11 for the auxiliary hoist); ■■■► *Operating manual*.
- The main boom must be raised and fully extended; ■■■► *Operating manual*.

Checking the ropes

- Start the engine.
- Unreel the rope and check the rope and the rope spooling; ■■■► *Assessing the condition of the hoist rope*, P. 8 - 100. When 5 turns are left on the rope drum, the lowering limit switch must switch off.

If the lowering limit switch does not switch off or switches off too late, it must be reset; ■■■► *Setting the lowering limit switch*, P. 8 - 109.

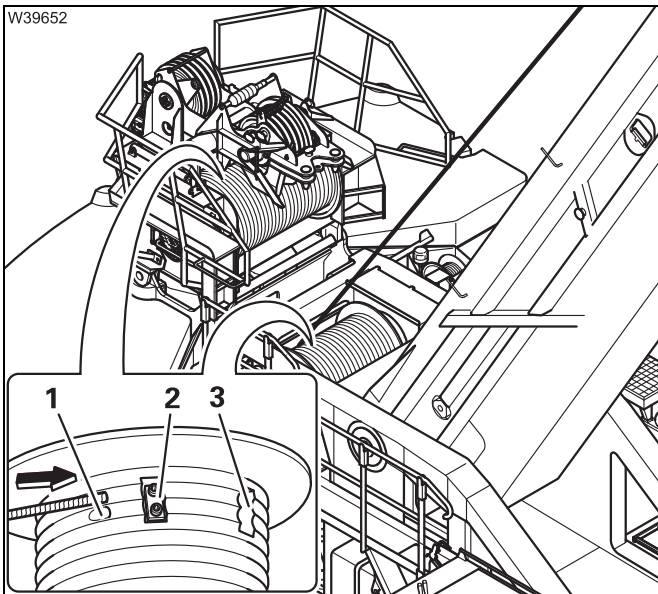

- Check the clamp (2) for damage and firm seating – torque 80 Nm (59 lbf ft).
- The rope end must not protrude out of the bore hole (1).
- The rope wedge must be in the pocket (3).
- The rope end on the rope wedge must not show any signs of wear.
- Reel in the rope. At the same time, the rope may not show any signs of kinking or being flattened.

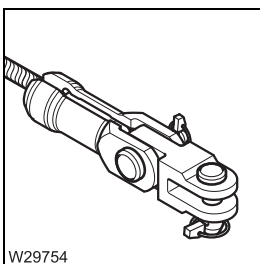

- Check the end of the rope and the rope end fitting for damage.
- Make sure the rope end is correctly fitted in the rope end fitting; ■■■► *Operating manual*.

8.12.3

Lubricating the hoist rope

M 3

Grease, spare parts and tools

Designation	Quantity	GROVE part no.
Grease	1	03133770

- brush, roller, spray gun, tray or pressure pump.

Lubricating the rope

- lubricating the rope
- significantly prolongs its service life and
- keeps the friction between the rope, the sheaves and the hoist drum as low as possible.

The lubricant is applied to the rope by

- spraying, brushing, rolling or
- by running it through a tray filled with lubricant or
- by means of high-pressure lubrication with a pressure pump.



Manitowoc Crane Group Germany GmbH recommends high-pressure lubrication with a pressure pump (GROVE part no. 90018525) for reasons of sustainability, efficiency and environmental protection.

When lubricating the hoist ropes, observe the instructions concerning the lubricant.

When using the pressure pump, observe the manufacturer's separate operating instructions.

For further information, contact **Manitowoc Crane Care** or an authorised GROVE dealer.

8.12.4

Assessing the condition of the hoist rope



If in doubt about damage assessment, always consult an approved inspector.

To assess the condition of the rope, you must be familiar with the following:

- The type of rope (lang lay rope),
- The number of load bearing wires in the outer strand,
- The rope diameter (▣▣▣▣▶ *Operating manual*).

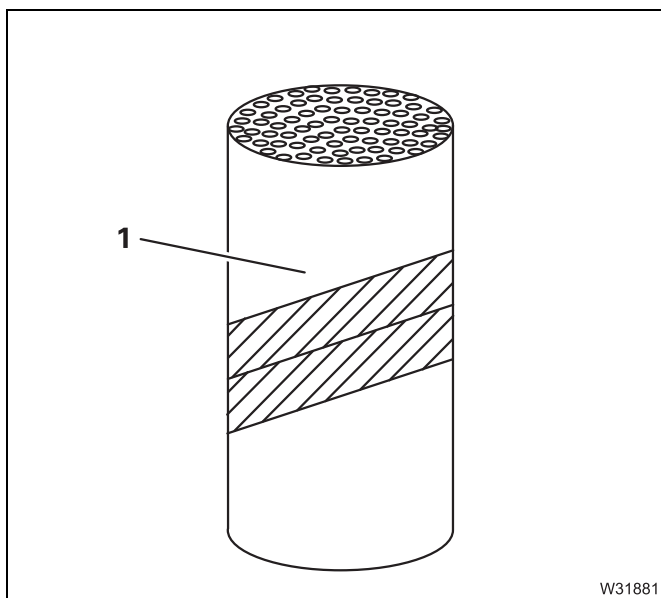

In a lang lay rope (**1**) the wires run at an angle of approximately 45° to the longitudinal direction of the rope.

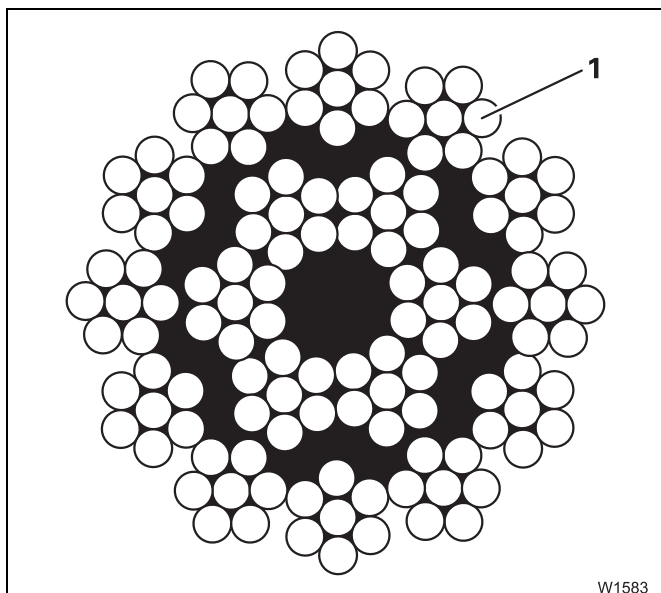

The number of load-bearing outer wires (**1**) is found by counting the number of outer strands of the rope and multiplying by 7.



If there are multiple layers of strands, only the outer layer is counted.

The **tables** show by rope diameter the number of wire breaks in a length 6 times and 30 times the rope diameter which if reached would require replacement of the rope.

- Familiarise yourself with DIN ISO 4309:2013-06 (rotation-resistant ropes).

This table applies only to the **hoist ropes** fitted as initial equipment and original replacement ropes!

Number of visible wire breaks on a rotation-resistant hoist rope						
The rope section runs over a rope disc or on a drum wound as a single layer						
Number of load-bearing outer wires	Ø 13 mm		Ø 16 mm		Ø 17 mm	
	to 78 mm	to 390 mm	to 96 mm	to 480 mm	to 102 mm	to 510 mm
101-120	3	5	3	5	3	5
121-140	3	5	3	5	3	5
The rope section is running on a drum wound as multiple layers						
	Ø 19 mm		Ø 22 mm		Ø 24 mm	
	to 114 mm	to 570 mm	to 132 mm	to 660 mm	to 144 mm	to 720 mm
101-120	3	5	3	5	3	5
121-140	3	5	3	5	3	5
The rope section is running on a drum wound as multiple layers						
	Ø 13 mm		Ø 16 mm		Ø 17 mm	
	to 78 mm	to 390 mm	to 96 mm	to 480 mm	to 102 mm	to 510 mm
101-120	5	10	5	10	5	10
121-140	6	11	6	11	6	11
	Ø 19 mm		Ø 22 mm		Ø 24 mm	
	to 114 mm	to 570 mm	to 132 mm	to 660 mm	to 144 mm	to 720 mm
101-120	5	10	5	10	5	10
121-140	6	11	6	11	6	11





Risk of accidents due to reduced load bearing capacity!

Remember that other factors may also make it necessary to replace a rope before the number of wire breaks requiring rope replacement has been reached (age of rope, frequency of use or exceptional loading).

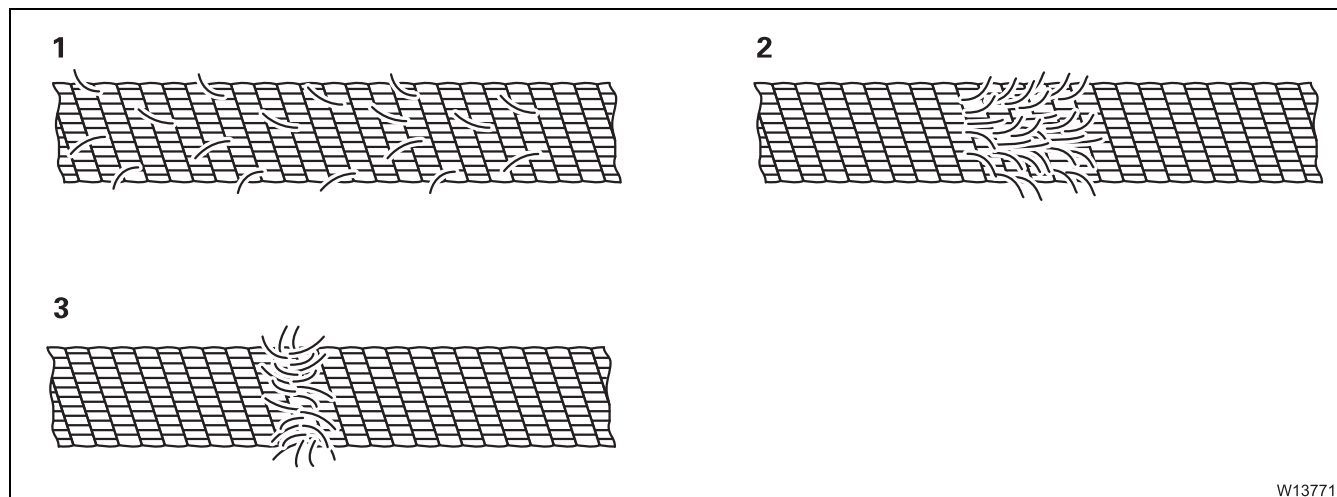

W13771

Damage	Description	Cause	Replacement
Wire break (1)	Individual wires are broken; the broken ends of the wires are protruding from the rope.	General wear caused by ageing of the rope or Subsequent damage resulting from damage to the rope.	Replace the rope at the latest when the maximum permissible number of wire breaks according to the table are visible externally. Replace the rope immediately if wire breakage clusters or strand breakages occur. The frequency of wire breaks increases as the rope ages. For safety reasons, it is advisable to replace the rope while the number of wire breaks is still low.
Wire break-age cluster (2)			
Strand break-age (3)			
Effect of heat	Tarnished colour is visible externally on the rope.	Rope has been subjected to excessive heat.	Replace the rope immediately .

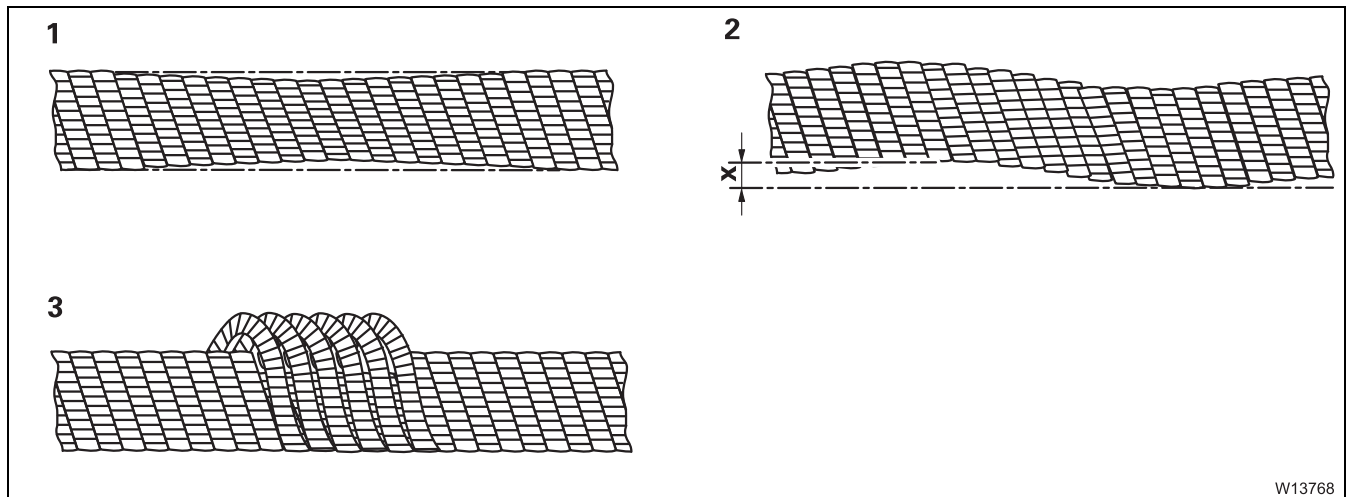

Damage	Description	Cause	Replacement
Reduced diameter (1)	The diameter of the rope has become smaller along large sections.	Structural changes	Replace the rope immediately if the diameter has decreased by 15% or more compared to the nominal diameter.
		Corrosion or abrasion.	Replace the rope immediately if the diameter has decreased by 10% or more compared to the nominal diameter.
Corkscrew-type rope deformation (2)	The rope winds its way along its longitudinal axis in a way that is similar to a corkscrew. Deformation is measured with suspended hook block.	Damage resulting from overloading.	Even a small amount of deformation leads to increased abrasion, wire breaks and rough operation of the rope drive. If deformation "x" at a position on the rope is greater than a third of the rope diameter, the rope must be replaced immediately .
Basket like deformation (3)	Wires of the outer layer protrude. In other areas of the rope, the insert has buckled or is protruding from the rope.	Outer and inner layers have been displaced in relation to each other.	Replace the rope immediately.



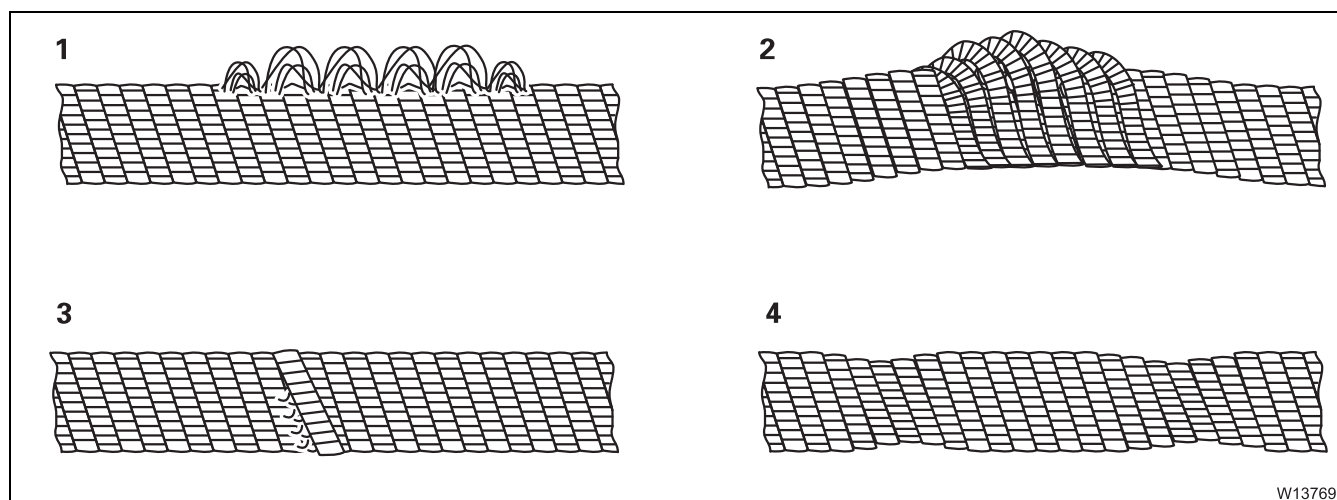

Damage	Description	Cause	Replacement
Loop formation (1)	Outer layer wires in the form of hair pins are protruding from the rope away from the sheave.	General wear due to ageing of the rope or consequential damage as a result of damage to the rope.	Immediately replace the rope if the rope structure has been substantially altered by the loop formations.
Loosening of wires or strands (2)	Outer wires or strands have become loose. Only the inner strands continue to bear the load.	Corrosion or abrasion.	Replace the rope immediately .
		Other causes.	The number of wire breaks determines when the rope must be replaced.
Knot formation (3)	If there is repeatedly occurring knot-like thickening of the rope; the insert comes out frequently. Strands bear on each other at thin points; increased frequency of wire breaks.	General wear due to ageing of the rope or consequential damage as a result of damage to the rope.	Determine number of wire breaks; replace rope immediately if serious knot formation occurs.
Constriction (4)	Diameter reduction over short sections.	General wear caused by ageing of the rope.	Replace rope immediately if serious constrictions are detected.

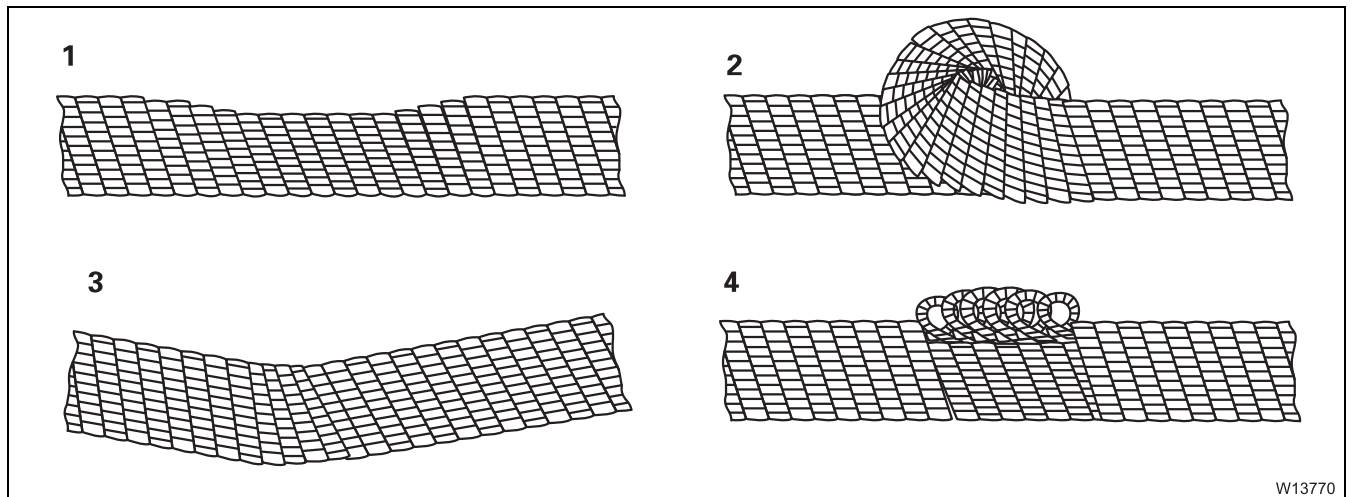

Damage	Description	Cause	Replacement
Flattening (1)	Crushed areas, mostly with wire breaks.	Mechanical damage, e. g. due to driving over the rope.	Determine number of wire breaks; replace rope immediately if serious crushing has occurred.
Kink (2)	Rope deformation with twists and wire breaks.	Rope in the eyelets was pulled straight while twisted.	Replace the rope immediately .
Kinks (3)	Buckled section in the rope.	Mechanical damage.	Replace the rope immediately .
Crinkling (4)	Crinkling rope deformation.	Loaded rope was pulled over an edge.	Replace the rope immediately .

8.12.5

Replacing the hoist rope

Spare parts and tools

- An original replacement part; ■■■▶ *Rope certificate*.
- A reel stand with braking block.
- Torque wrench for 80 Nm (59 lbf ft).



Risk of accidents from falling load!

Use only a replacement rope that has the same technical specifications as the defective rope, or an authentic replacement rope.

Prerequisites

- The truck crane must be level.
- The main boom is set down on the boom rest.
- The hook block must be unreeved; ■■■▶ *Operating manual*.

Replacing the old rope

- Unreel the hoist rope until it switches off.
- Adjust the lowering limit switch so that you can unreel the rope completely; ■■■▶ *Setting the lowering limit switch*, P. 8 - 109.
- Unreel the remaining layers from the hoist drum.
- Lock the truck crane to prevent unauthorised use; ■■■▶ P. 2 - 3.



Risk of accidents due to the rotating rope drum!

Switch the engine off and remove the ignition key so that no unauthorised operation of the hoist can occur.

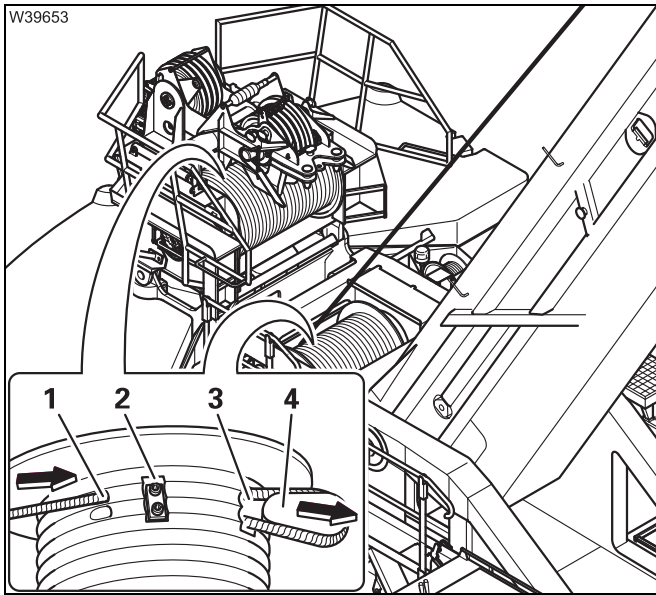

- Remove the clamp (2).
- Push the rope (1) through the bore hole (3) until the rope wedge (4) slides out of the pocket.
- Remove the rope wedge and place the old rope away from the truck crane.

Inserting a new rope

The service life of a rope can be significantly affected by the insertion procedure. Errors can significantly reduce the service life, therefore:

- Make sure the rope is not twisted when it is inserted.
- Avoid soiling and damage when fitting.
- Wind the rope up in the same direction in which the rope is reeled on to the reel.
- Tense the rope slightly while winding it up.

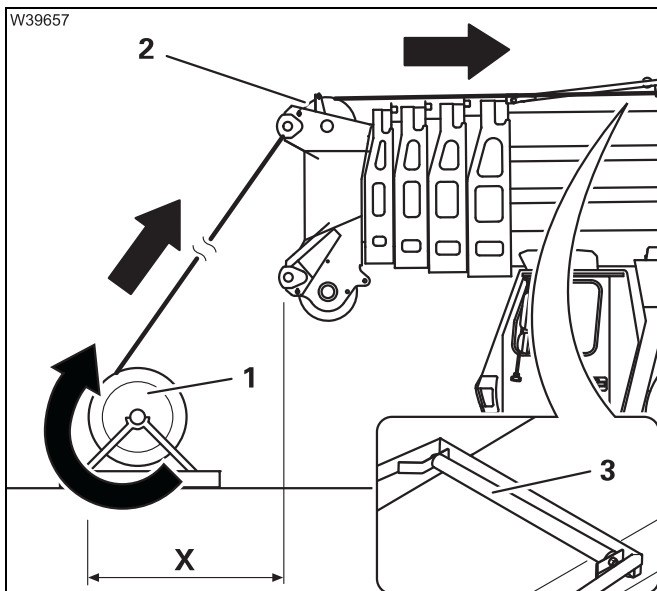

- Place the reel stand (1) with the new rope in front of the main boom head.

The distance (X) between the reel stand (1) and the head sheave (2) must be at least 30 m so that the rope runs over the head sheave as straight as possible.

Ensure that the rope is being rolled on to the drum with the right slewing direction.

- Guide the rope over the head sheave (2) and under the bracket (3) up to the hoist drum.



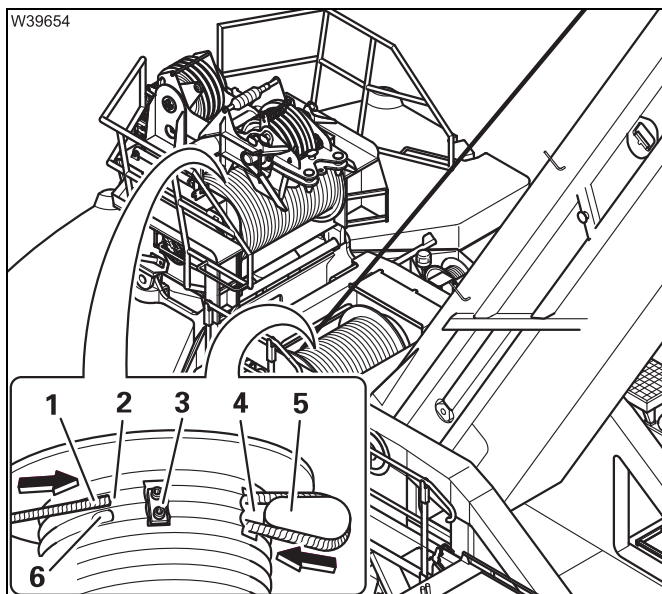

- Push the rope (1) through the bore (2), until it protrudes approx. 1.5 m (5.0 ft) out of the pocket (4).
- Feed the free end of the rope back through the pouch into the hole (6).
- The rope end must not protrude out of the bore hole (6).
- Secure the clamp (3) and tighten it – torque 80 Nm (59 lbf ft).
- Place the rope wedge (5) in the loop.

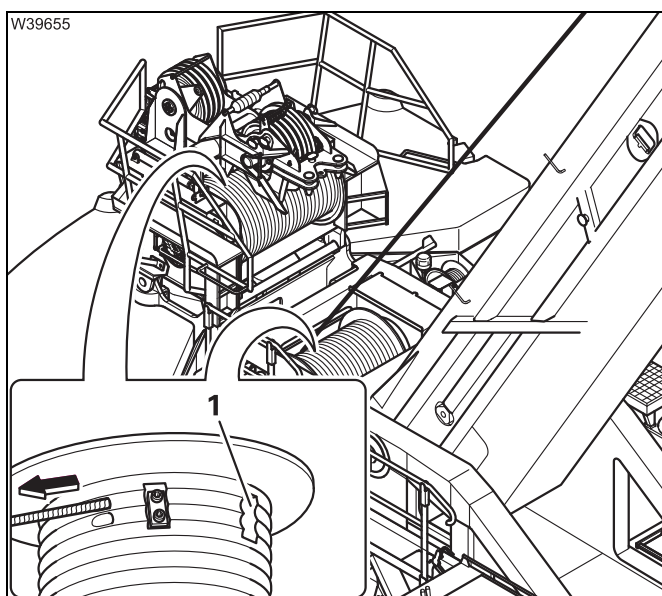

- Push the rope back until rope wedge slips fully into the pouch (1).

- Start the engine.
- Hold the rope taut and wind up the rope slowly.
- Reeve a hook block in – the reeve for the main hoist must have at least six lines, and at least 11 lines for the auxiliary hoist;  *Operating manual*.
- Raise the main boom to a steep position and extend it fully.
- Unwind the rope until only five turns remain on the rope drum.



Observe the hook block when unreeling.
The hook block must not rotate!



Risk of accidents if the lowering limit switch is set incorrectly!

After inserting a new rope, the lowering limit switch must always be reset. In this way you avoid the lowering limit switch switching off too late or not at all, the rope being damaged and the load being dropped.

- Set the lowering limit switch; ▮▮▮▮▶ P. 8 - 109.
- Run in the new rope with small loads so that the rope can settle on the hoist drum.

8.12.6

Setting the lowering limit switch

A lowering limit switch is mounted both on the main hoist and on the auxiliary hoist.

Spare parts and tools

Designation	Quantity	GROVE part no.
Cover gasket	2	03137794

Prerequisites

- A hook block is reeved (reeve for the main hoist has six lines, and 11 for the auxiliary hoist); ▮▮▮▮▶ *Operating manual*.
- The main boom is fully raised and extended; ▮▮▮▮▶ *Operating manual*.
- The hook block is lowered until only five turns of the rope remain on the hoist drum.



Setting the lowering limit switch



Risk of accidents if the rope end fitting is overloaded!

The lowering limit switch must always be reset after repair work on the hoist and after rope replacement. A faulty lowering limit switch must always be replaced!

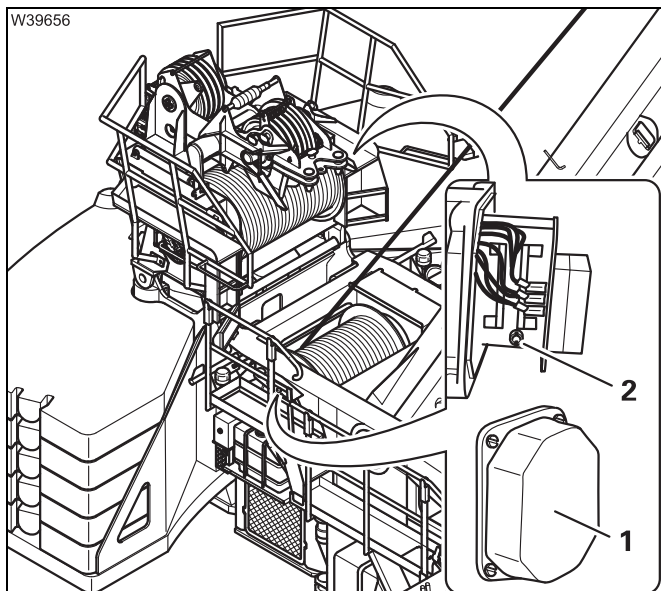

- Remove the cap (1).
- Turn the screw (2) until you hear the switch activate.
- Screw the cover on again.
Replace the gasket if necessary.
- Check that the lowering limit switch switches off the hoist correctly.

Checking switch-off

- Raise the hook block until there are approx. 10 turns on the hoist drum.
- Lower the hook block and check whether the lowering limit switch switches off properly.

The lowering limit switch must switch off the hoist while five rope turns are still on the hoist drum.

- Correct the setting of the lowering limit switch if necessary.

8.13

Cable drums and slewing angle sensor

8.13.1

Maintenance of the slip ring assemblies

M 6

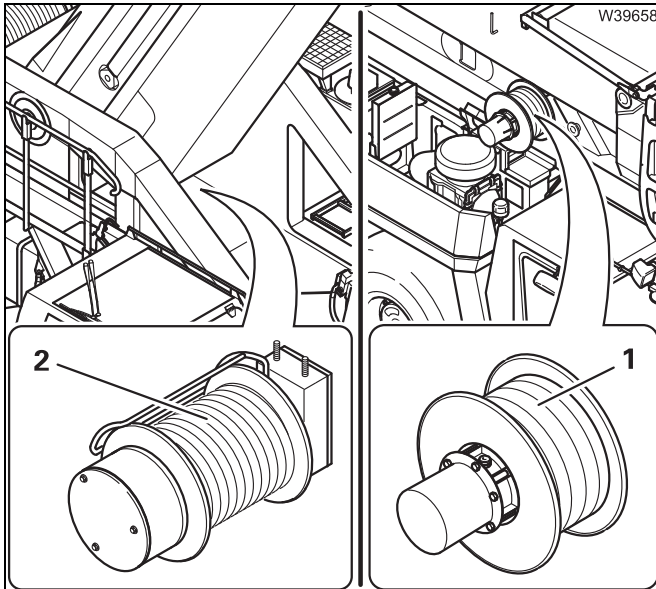

The slip ring assemblies are located in:

- 1 Cable drum 1
- 2 Cable drum 2

Spare parts and tools

Designation	Quantity	GROVE part no.
Cover gasket for cable drum 1	1	02313293
Cover gasket for cable drum 2	1	03137971

- Clean, lint-free cloth.
- Dry, oil-free compressed air.

Prerequisites

For cable drum 1

- The main boom must be set down on the support; *Operating manual*.

For cable drum 2

- The main boom must be fully raised; *Operating manual*.

For cable drums 1 and 2

- The engine must not be running and must be secured against unauthorised use; P. 2 - 3.
- The selector handle must be removed from the battery master switch.





Risk of damage to the RCL!

Before maintenance work on the slip ring assemblies, always switch off the battery master switch so that the cable drum is without power. This prevents short circuits which may lead to damage to the rated capacity limiter (RCL).



Risk of crushing from movement of the main boom!

Perform maintenance work only after the truck crane has been shut down. Always ensure that the truck crane is protected from unauthorised use before beginning maintenance work. Remove the keys from the crane cab and put up warning signs.

Maintenance of the slip ring assemblies

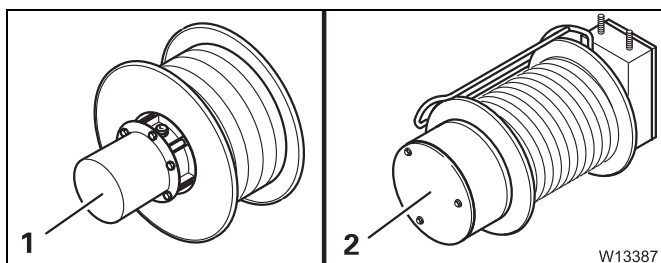

- Remove the cover (1) or (2).
- Clean and dry the cover.
- Replace the gasket if necessary.

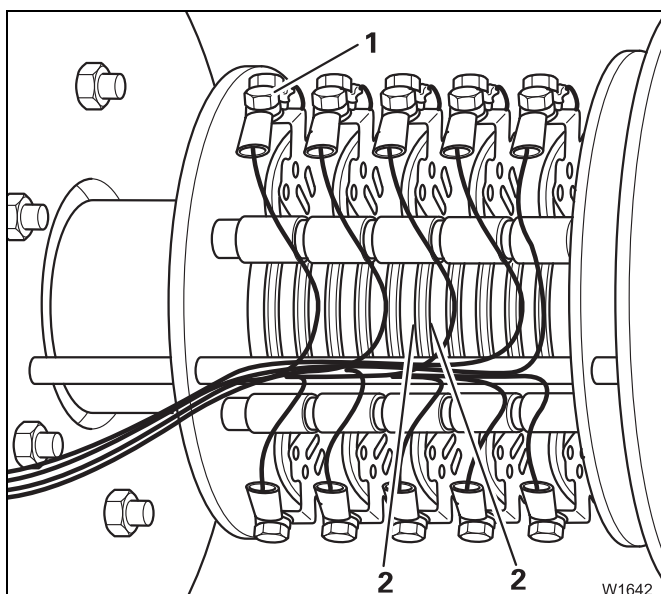

- Only use a cloth and compressed air to remove any dirt on the slip rings (2).
- **Do not** use spray oil.
- Check to make sure all screws (1) are tight.
- Attach the cover to the cable drum.

8.14

Central lubrication system

8.14.1

Checking the filling level

W

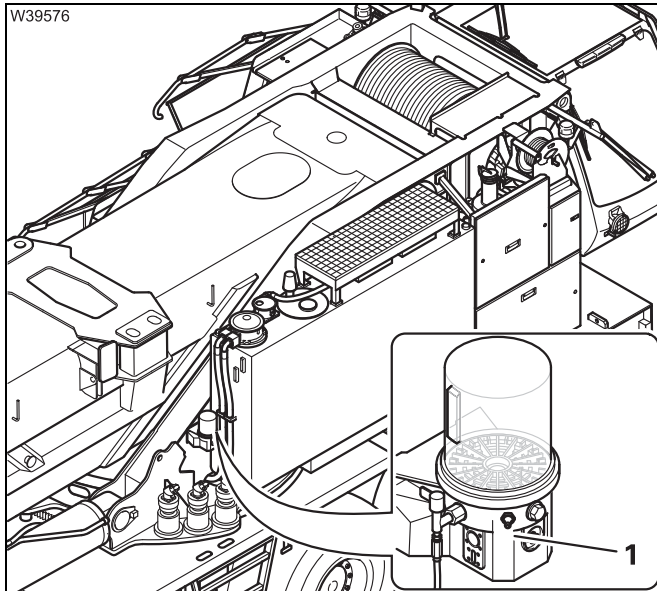

The maintenance of the pump (1) is the same as the maintenance on the carrier;  *Central lubrication system*, P. 7 - 103.

Connected lubricating points

- Main hoist drum,
- Slewing bearing,
- Telescopic boom – pivot pins,
- Derricking cylinder – pivot pins.

Lubricating points not connected

- Auxiliary hoist drum;  P. 8 - 45.

Blank page

8.15 Hook blocks

8.15.1 Checking the sheaves

M 3

- Check the sheaves in the hook blocks for damage, wear, mobility and extreme soiling.

Have damaged, worn, stiff or extremely soiled sheaves replaced by **Manitowoc Crane Care** or an authorised GROVE dealer or your repair crew.

8.15.2 Greasing

M 12

- Also adhere to the  *Run-in regulations*, P. 4 - 1.

Grease, spare parts, tools

Lubricating grease	Designation to DIN 51502	Specifications Classification	GROVE part no.
Grease	KP - 1K - 50	DIN 51825	03233369

- Grease gun from the tool set.

Prerequisites

- The hook block has been reeved at least twice;  *Operating manual*.

Greasing



On the hook blocks supplied, the sheaves, crossheads and load hooks of the axial bearings are greased.

The sheaves on the hook block often have no grease nipple and are maintenance-free.

- Check all hook blocks for grease nipples. Hook blocks with grease nipples must be serviced, hook blocks without grease nipples are maintenance-free.



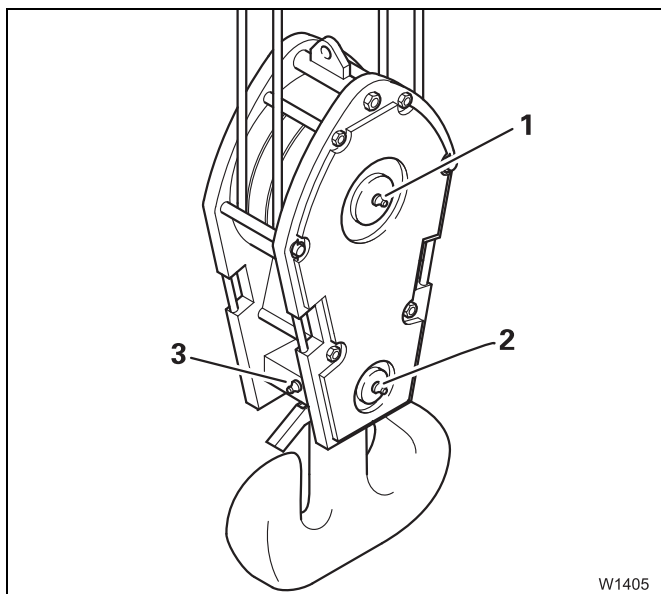

The diagram gives an example of the arrangement of the grease nipples (1), (2) and (3) on a hook block.

There are more grease nipples on the other side.

- Clean the grease nipples on all hook blocks and grease them using a grease gun.

Having them dismantled

Depending on the manufacturer, there are different maintenance intervals for the dismantling of the hook blocks. The maintenance-free sheaves are also greased at this time. Some manufacturers recommend dismantling every 4 years or after 500 operating hours.

- Ask **Manitowoc Crane Care** about the maintenance intervals for the hook blocks supplied with your crane.
- Have the hook blocks dismantled by **Manitowoc Crane Care** or an authorised GROVE dealer or your qualified repair crew.

8.16

Electrical system

8.16.1

Checking the lighting and indicators

D



Risk of accidents if the safety devices are faulty!

Have faulty lights and indicators repaired by **Manitowoc Crane Care** or an authorised GROVE dealer or an authorised specialist workshop.

- Check the lamps and displays on the *ECOS* and *RCL* control units;
 ▶ *Operating manual*.

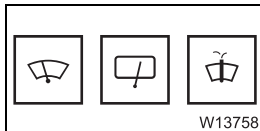

- Check the following functions:
 - Windscreen wipers, windscreen washing system,

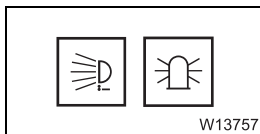

- Spotlight on the crane cab, air traffic control light,
- Spotlight on the main boom (xenon light),
- Horn, anemometer,
- Camera lights on the main and auxiliary hoists.



Risk of accidents from exploding glass bodies and high voltage!

The glass bodies of gas discharge lamps (xenon lights) are pressurised. If the lamp breaks, the glass splinters explosively and shards scatter. Xenon lights operate at high voltage. While changing the lamp, there is still a danger of residual voltage discharging (electric shock) even when the battery master switch is switched off.

Have faulty lamps replaced only by properly qualified personnel who use the relevant protective equipment.

- Have faulty lamps in the spotlights replaced only by qualified personnel.

8.16.2

Checking the batteries

M 1

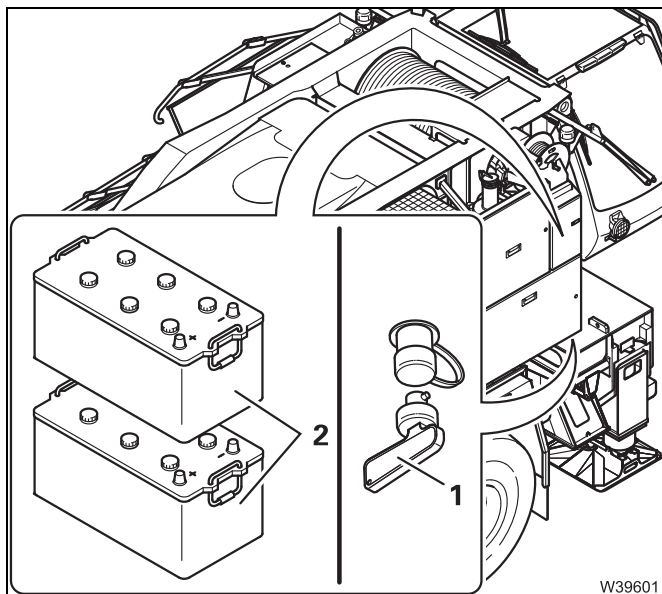

- Switch the battery master switch (1) off and remove the selector handle.
- Check the batteries (2) in the same way as when checking them on the carrier;
 ▣▣▣▣▶ *Checking the batteries, P. 7 - 108.*

8.16.3

Checking the charge level of the batteries

M 3

- Check the charge state in the same way as when checking it on the carrier;
 ▣▣▣▣▶ *Checking the charge level of the batteries, P. 7 - 110.*

8.16.4

Charging the batteries using the battery charger

M 3

Prerequisites

- The engine must not be running and must be secured against unauthorised use;  P. 2 - 3.
- An external 230 V mains power supply must be available at the location.
- The battery charger (GROVE part no. 03320239; additional equipment) must be available.
- The location must be well ventilated and protected against moisture. The battery charger may not be used at locations where there is risk of a gas or dust explosion.

Battery charger

- Familiarise yourself with the correct operation of the battery charger;  *Separate operating manual.*

Connecting

- Take the battery charger out of its storage compartment in the driver's cab.

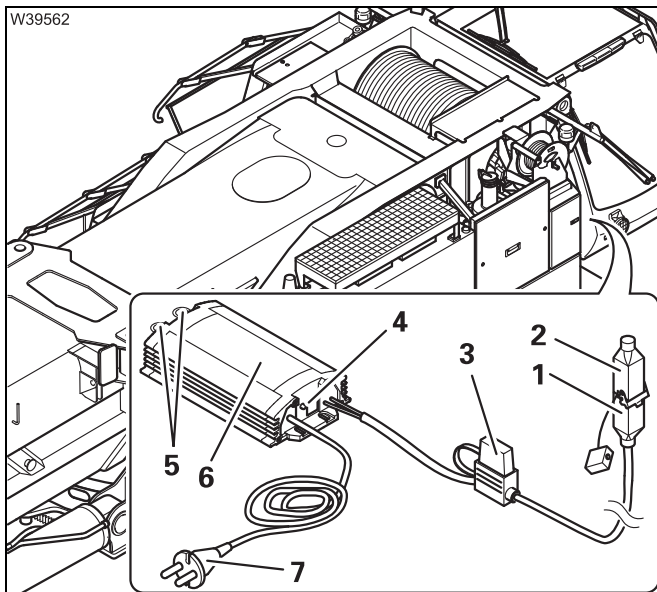

- Insert the plug (1) into the socket (2) on the battery box.
- Place the battery charger (6) in a protected place where you can see the indicator lamp (4).
The battery charger can be suspended from the ring eyes (5).
- Insert the plug (7) into the socket on the mains supply 230 V at the location.
The indicator lamp (4) flashes – the charging process starts.
- If the indicator lamp (4) does not flash, check the fuse (3).

Charging

- Check the charging process at the indicator lamp (4).

Indicator lamp flashing: The batteries are being charged.

Indicator lamp lit continuously: The batteries are fully charged.

After completion of charging

- Remove the plug (7) from the 230 V mains supply.
- Remove the plug (1) from the battery box.
- Return the battery charger to the storage compartment in the driver's cab.

Blank page

8.17 Air-conditioning system

8.17.1 Checking the air-conditioning system

M 1

The air-conditioning control panel is located on the side panel in the crane cab.

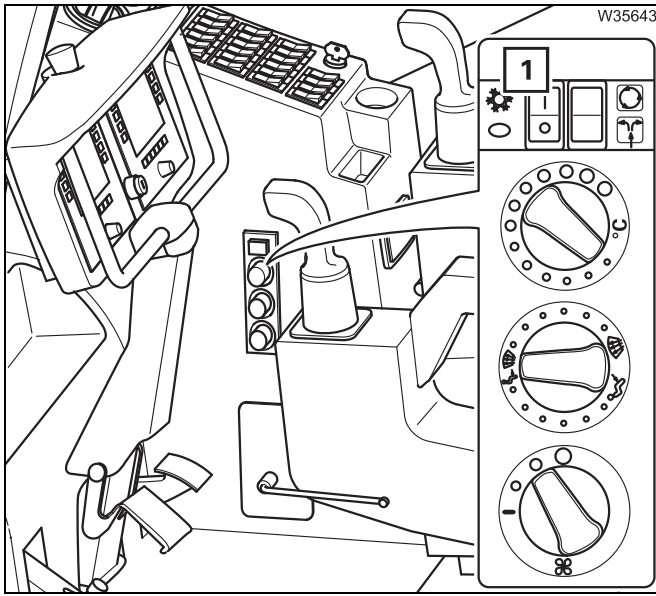

- Switch on the air conditioning system (1);
 ▣▣▣▣▶ *Operating manual*.
- Check that cooling takes place. If it does not, the air-conditioning system is defective.
- Switch off the air conditioning system (1).

If the air-conditioning system is defective

- Do not start it up again to avoid further damage.
- Have the air-conditioning system repaired as soon as possible by **Manitowoc Crane Care** or an authorised GROVE dealer or an authorised specialist workshop.

8.17.2 Checking hoses

M 6



Risk of burns due to escaping refrigerant!

Wear suitable safety glasses and gloves when checking the hoses and connections.

This will prevent injury from suddenly escaping refrigerant. Seek medical attention if the skin or eyes come into contact with the refrigerant.

- Check all refrigerant hoses for damage and areas of wear.

Have damaged hoses replaced only by **Manitowoc Crane Care** or an authorised GROVE dealer or an authorised specialist workshop.

8.17.3

Cleaning the condenser fins

M 12



Risk of damage to the condenser!

Do not use a high pressure cleaner or steam jet cleaner. The powerful jet may damage the fins. Use only compressed air for cleaning.

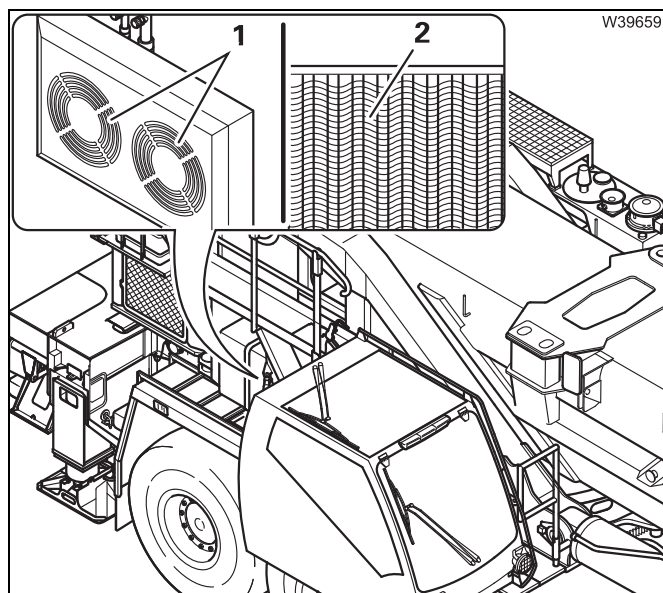

- Switch the air-conditioning system off.
- Clean the condenser fins (2) and the fans (1) with compressed air.

8.17.4

Checking the entire air-conditioning system

M 12



This inspection may only be performed by **Manitowoc Crane Care** or an authorised GROVE dealer or an authorised specialist workshop!



Risk of burns due to escaping refrigerant!

Wear suitable safety glasses and gloves when checking the hoses and connections.

This will prevent injury from suddenly escaping refrigerant. Seek medical attention if the skin or eyes come into contact with the refrigerant.

- Have the entire air-conditioning system checked for leaks and proper functioning.
The inspection of the air-conditioning system particularly includes the inspection of
 - the refrigerant collector, in accordance with the pressure container regulations (test group II) and
 - the refrigerant compressor.

Only allow the system to be topped up with suitable refrigerant.

Refrigerant

Fill quantity in kg (lbs)	Designation	CAS no. EC no.
1.45 (3.2)	Tetrafluoroethane (R134a)	811-97-2 212-377-0

Filler connections

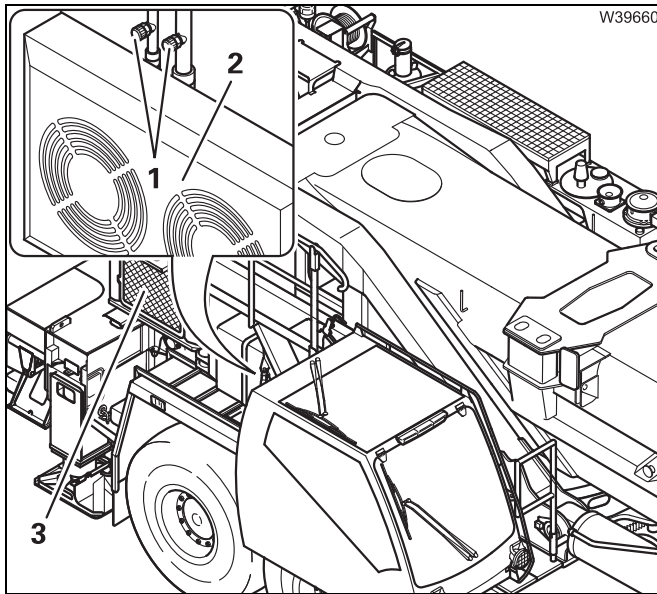

The refrigerant filler connections (1) are located on the lines between the refrigerant compressor (3) and the condenser (2).

Blank page

8.18 Other maintenance work

8.18.1 Checking the windscreen washing system

W

Water, spare parts, tool

Designation	Quantity	GROVE part no.
Windscreen wiper blade	1	03322652
Roof wiper blade	1	03322631

- Water; add commercially available detergent and antifreeze to it.
- A can for mixing and filling.

Prerequisites

- The crane cab is slewed away from the rear of the carrier – the cover (1) is accessible.

Topping up

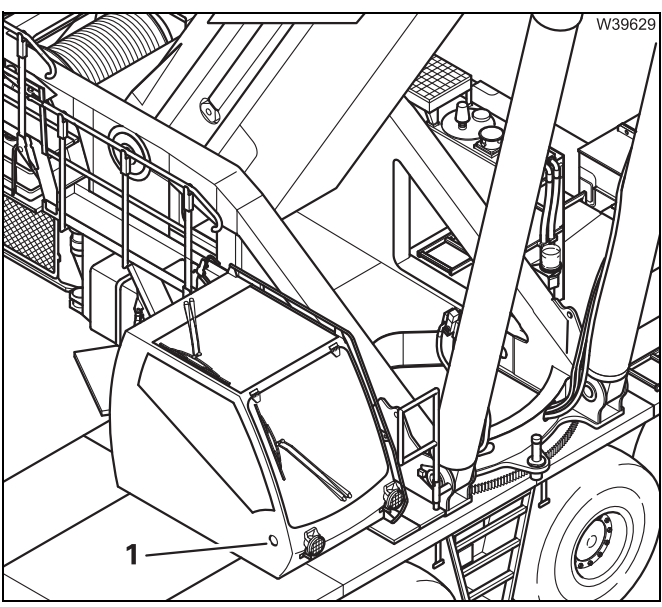

If the tank is empty

- Open the cap (1) on the filler neck.
- Top up the windscreen washing fluid through the filler neck.
- Close the filler neck with the cap.



Wiping

The wiping/washing system operation is described in the accompanying operating instructions;  *Operating manual*.

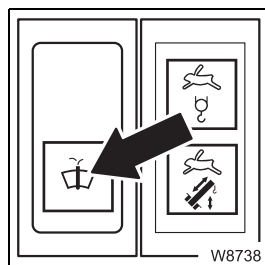

- Spray water on the **windscreen** – press the **bottom** part of the switch.
- Spray water on the **skylight** – press the **top** part of the switch.

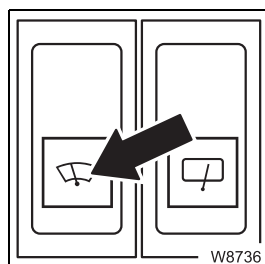

- Switch the **windscreen wiper** on – press in the **bottom** part of the switch for continuous operation.
- Also check intermittent operation – push the switch in the middle position.
- Switch the **windscreen wiper** off – press in the **top** part of the switch.

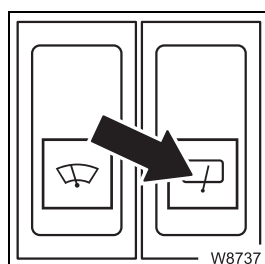

- Switch the **roof window wiper** on – press in the **bottom** part of the switch for continuous operation.
- Also check intermittent operation – push the switch in the middle position.
- Switch the **roof window wiper** off – press in the **top** part of the switch.

In case the windscreen/skylight is not wiped clean:

- Change the wiper blade.

8.18.2

Checking the functioning of the auxiliary heater

M 1

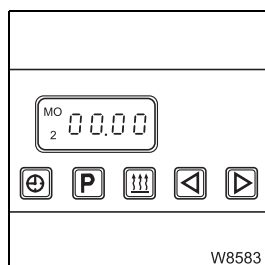

Check the auxiliary heater in the same way you check it on the carrier;
 *Checking the functioning of the auxiliary heater, P. 7 - 121.*

8.18.3

Lubricating the crane cab door

M 12

Grease, spare parts, tools

Designation	GROVE part no.
Grease: RHUS 2 AF, 1 kg can	03325215

– Brush.

Prerequisites

– The engine must not be running and must be secured against unauthorised use;  P. 2 - 3.

Greasing

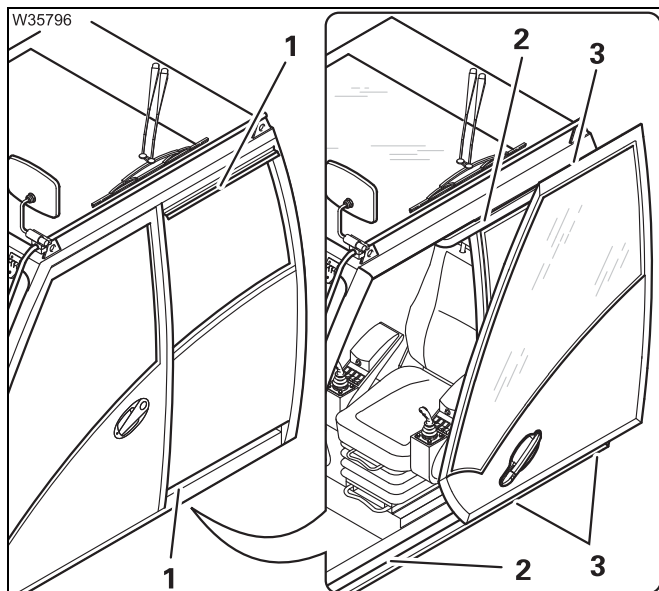

- With the door closed, clean the rails (1) outside.
- Grease the rails (1) lightly with a brush.
- Open the door and slide it fully open – the door locks in place.
- Clean the rails (2).
- Grease the rails (2) and the rollers (3) lightly with a brush.
- Check if the door moves smoothly on the rails and if it locks easily.

If the door is sluggish or does not close properly, have it adjusted by **Manitowoc Crane Care** or an authorised GROVE-dealer.

8.18.4

Lubricating the connecting and socket pins

M 12

Grease, tools

Lubricating grease	Designation to DIN 51502	Specifications Classification	GROVE part no.
Grease	KP - 1K - 50	DIN 51825	03233369

- Brush.

Checking

Depending on the equipment, the **superstructure** can have various connecting pins and socket pins such as:

- Hinged or fold out railings,
 - Locks and supports on the covers,
 - Hinges on the covers,
 - Hinges on the crane cab's front and the rear window,
 - Retaining rods for the rope discs at the head of the main boom.
-
- Check the pins for wear such as rust, deformation, broken clips, chains and pin-type keepers.
 - If the pins are damaged, have them replaced by **Manitowoc Crane Care** or an authorised GROVE dealer or your qualified repair crew.
 - Use only authentic replacement pins.

Greasing

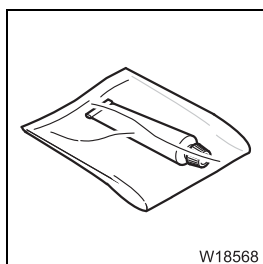

- Clean the pins.
- Lubricate the pins with a brush.

8.18.5

Renewing the corrosion protection

M 12

Protective agent, tools

Protective agent	GROVE part no.
Corrosion protection	03140192

- Spray gun with spray extension.
- Brush.
- Protective clothing, protective goggles.

Prerequisites

- The superstructure must be thoroughly cleaned.
- The engine must not be running and must be secured against unauthorised use;  P. 2 - 3.

Checking

Some particular parts of the superstructure were sprayed for corrosion protection for the first time in the factory itself.

These are pumps, valve blocks, controls and fittings, pipes, screw connections, hose fittings of the hydraulic system of the superstructure;  P. 8 - 130.

The corrosion protection is solvent-free and is water soluble while being sprayed on. A transparent, waxy, protective film is formed after a drying time of one hour.

- Check the condition of the original protective film.
- If required, remove any rust and touch up the paintwork before you spray on a new protective film.

Processing instructions

- Observe the processing instructions for corrosion protection;  *Processing instructions*, P. 7 - 123.



Spraying



Risk of injury to the eyes!

While working with the spray extension you could be hit by the spray jet or spray droplets. Wear protective goggles, protective clothing and gloves.

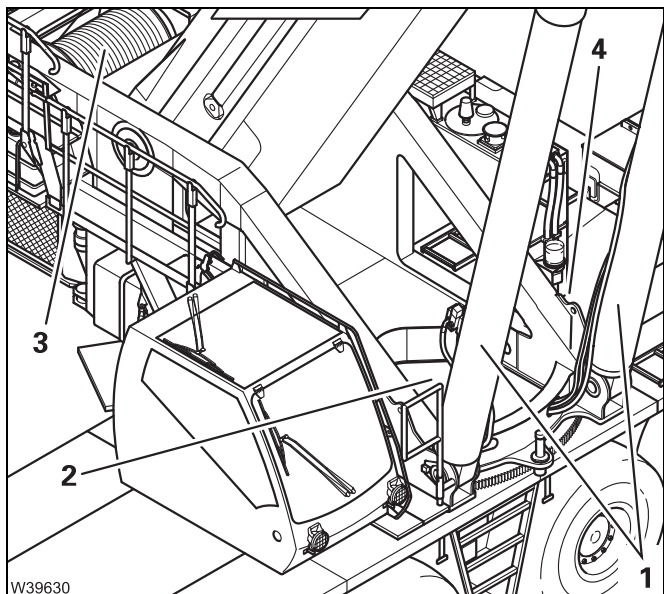

- Make sure that you do not spray running surfaces. There is a risk of slipping!
- Spray the corrosion protection with a spray gun aimed only at the pumps, valve blocks, screw connections, pipes, hoses of the hydraulic system of the superstructure:
 - At the derricking cylinders (1),
 - On the slewing duct (2),
 - On the hoists (3),
 - On the slewing gears (4).
- Clean surfaces sprayed by accident immediately with water.

- Let the corrosion protection dry for one hour.
- Check that a transparent waxy protective film has covered the entire surface.

8.18.6

Having the fire extinguisher checked

Y 2

Depending on your truck crane's equipment, it can be fitted with fire extinguishers.



The maintenance interval may even be shorter, depending on the respective national regulations and the operating location. Ask the local fire safety officer about the national and local regulations.

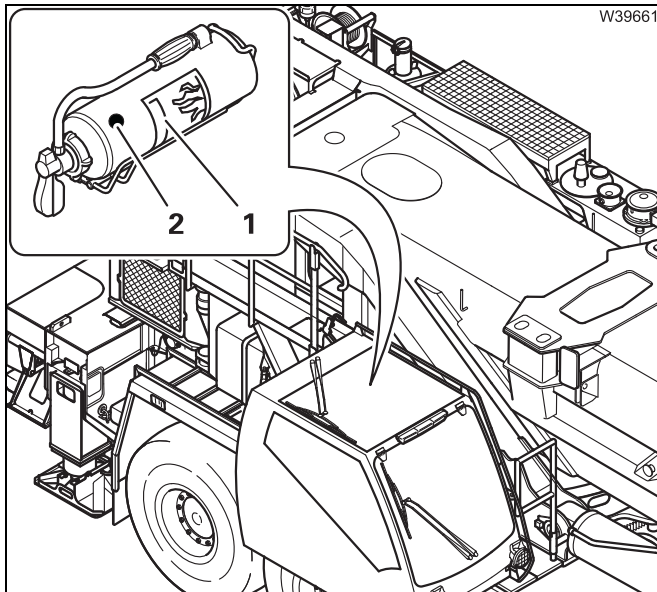

- Observe the instructions (1) on the fire extinguisher.
- Have the fire extinguisher serviced by trained personnel in good time before the maintenance interval specified on the label (2) expires.



Danger due to the fire extinguisher not working!

There is no guarantee that the fire extinguisher will still work properly once the maintenance interval on the label has expired.

Blank page

9 Longer out of service periods

9

Longer out of service periods

Carry out the following jobs if the truck crane is going to be out of service for a long period (months).

Putting the truck crane out of service

- Clean the truck crane thoroughly on the inside and outside.
- Remove any rust and touch up the paintwork.
- Parts that are not painted must be lubricated with an acid-free grease or oil.

If more than half of the oil change interval has passed:

- Change the oil according to the maintenance plans **M 3** to **M 12**.
- Seal all the air filters.
- Increase the tyre pressure by 10% and mark the tyre positioning, or support the truck crane and leave it standing on the outriggers.
- Observe the specifications on preservation in the *Engine manufacturer's documentation*.

Checks

- Check the levels in the fuel tanks. Always keep the tanks filled.
- Check the batteries every week and recharge them if necessary.
- Check the tyre pressure every week and correct it if necessary.
- Perform a full functional test on the truck crane every two weeks. (Open all air filters beforehand!)
- Run the hydraulic systems up to a fluid temperature of approx. 50 °C (122 °F) and then check all functions of the carrier and superstructure hydraulic systems.



- Ensure that the tyre positioning is different each time the crane is parked (without outriggers).
- Seal all air filters again.

If the truck crane is going to be out of service for more than 12 months:

- Carry out all maintenance work in accordance with the maintenance plan **M 12**.
- Observe the specifications on preservation in the *Engine manufacturer's documentation*.

Putting the truck crane into operation

- Open all air filters.
- Inflate the tyres up to the prescribed pressure.
- Carry out periodic maintenance work in accordance with the maintenance plans in chapter 5.
- Observe the specifications on preservation and putting the truck crane back into service in the *Engine manufacturer's documentation*.

10 Torques

10.1	Torques for the retaining bolts	10 - 1
10.2	Special torques	10 - 2

10 Torques

10.1 Torques for the retaining bolts

Metric standard screw thread Metric fine thread			Guide values		
Thread size (mm)	Spanner size (mm)		Torques (maximum permissible pre-tensioning for bolts) for oiled bolts (Nm)		
	Hexagon-head bolt	Cylinder screw	Bolt quality		
			8.8	10.9	12.9
M 8 M 8 x 1	13	6	23 24	32 34	36 41
M 10 M 10 x 1.25	17	8	44 47	62 66	75 79
M 12 M 12 x 1.5	19	10	78 81	110 113	130 135
M 14 M 14 x 1.5	22	12	120 135	170 189	210 225
M 16 M 16 x 1.5	24	14	165 203	190 284	320 342
M 18 M 18 x 1.5	27	14	260 293	365 414	435 495
M 20 M 20 x 1.5	30	17	370 414	520 576	620 693
M 22 M 22 x 1.5	32	17	500 549	700 774	840 945
M 24 M 24 x 1.5	36	19	640 702	900 990	1,080 1,170
M 30	46	22	1,300	1,800	2,160
M 33	50	24		2,700	
M 36	55	27		3,300	

10.2 Special torques

Designation	Thread size (mm)	Size across flats (mm)		Torque (Nm)
		Hexagon-head bolt	Cylinder screw	
Suspension strut:				
– Bracket for the vehicle chassis, top	M 16	—	14	265
– Bracket for the vehicle chassis, bottom	M 24	—	19	900
– Suspension strut flange, bottom	M 20		17	520
– Half shell steering lever	M 16		14	265
– Upper steering arm on suspension strut	M 20	30	14	610
Steering linkage:				
– Ball-and-socket joints and steering track rods	M 10 x 1 M 12 x 1.5 M 14 x 1.5 M 24 x 1.5 M 30 x 1.5			45 - 55 70 - 85 140 - 160 250 - 280 450 - 500
Others:				
– Coolant hose clamps				4
– Wheel nuts	M 22 x 1.5	32		650
– Rim connection bolts (only for aluminium rims)		Aluminium rims with 20 nuts		550
		Aluminium rims with 22 nuts		385
– Retaining bolts for the Slewing bearing	M 30	46	—	1,560
– Hoist drum rope clamp	M 12	19	—	80

11 Spare parts required for maintenance

11.1	General information	11 - 1
11.2	Lighting	11 - 1
11.3	Spare parts for the carrier.....	11 - 5
11.4	Spare parts for the superstructure	11 - 8

11

Spare parts required for maintenance

11.1

General information

The spare parts required for maintenance are divided into

- lighting,
- spare parts for the carrier and
- spare parts for the superstructure.

The only spare parts listed here are those required for the maintenance work described.

A more detailed spare parts document can be found in the accompanying *Spare parts list*.

An overview of the required lubricants can be found in:

- *Lubricants list*, p. 6 - 2,
- *Lubricant applications list*, p. 6 - 3.

11.2

Lighting

Lamps are listed according to the installation point. The list includes standard and additional lighting equipment for the truck crane.

Lighting specific to certain countries can be found in the accompanying *Spare parts list*, in the section on country-specific packages.



Risk of accidents from exploding glass bodies and high voltage!

The glass bodies of gas discharge lamps (xenon lights) are pressurised. If the lamp breaks, the glass splinters explosively and shards scatter. Xenon lights operate at high voltage. While changing the lamp, there is still a danger of residual voltage discharging (electric shock) even when the battery master switch is switched off.

Have faulty lamps replaced only by properly qualified personnel who use the relevant protective equipment.



Installation point	GROVE part number	Designation	Power (W)
CARRIER LIGHTING:			
Front spotlights: (integrated in the bumper)			
– Daytime driving light	03328445	P21 W 24 V	21
– Low-beam + full-beam headlights	03134828	H7 24 V	70
– Low-beam + full-beam headlights (USA)	03143584	H9 12 V	65
– Indicator light	03327578	PY21 W 24 V	21
– Parking light (in direction indicator light)	03140908	LED	
– Yellow side marker light	03320937	LED	
Front, side direction indicator lights: (at the access ladder to the driver's cab)			
– Indicator light	00439055	P25-1 24 V	21
Rear lights: (only at the rear of the chassis, on the removable outrigger box and on the rear bumper)			
– Marker light	03137450	R5 W 24 V	5
– Number plate light	03137450	R5 W 24 V	5
– Rear light	03137450	R5 W 24 V	5
– Brake light	03328445	P21 W 24 V	21
– Indicator light	03137451	PY21 W 24 V	21
– Fog tail light	03328445	P21 W 24 V	21
– Reverse light	03328445	P21 W 24 V	21
Yellow side marker lights: (at the sides, along the chassis)			
– Side marker light	03140042	LED	
White rear marker lights: (at the rear of the chassis)			
– Left marker light	04164499	LED	
– Right marker light	04164500	LED	
Rear marker lights, red/white: (on the rear bumper)			
– Marker light, left and right	03329681		
Red triple light strip for USA: (only at the rear of the chassis, on the removable outrigger box and on the rear bumper)			
– Triple light strip	7581100056	LED	

Installation point	GROVE part number	Designation	Power (W)
White front marker lights: (at the top on the driver's cab)			
– Marker light	00438514	C5 W 24 V	5
Yellow additional lights for USA: (at the top on the driver's cab)			
– Yellow side marker light	03320937	LED	
Outrigger beam spotlights: (above the front and rear outrigger beams)			
– Filament lamp	02316460	8GH 002090251	70
Yellow rotating beacons: (on the driver's cab)			
– Rotating beacon; complete	04156048		
Inside lights: (in the driver's cab)			
– Filament lamp	00550434	K 24 V	10
Dashboard light: (in the driver's cab; socket 12V)			
– Filament lamp	04159964	Xenon	12V / 6W



Installation point	GROVE part number	Designation	Power (W)
SUPERSTRUCTURE LIGHTING:			
Marker lights, yellow: (on the main boom head)			
– Marker light; complete	03329569	LED	
Red rear marker lights: (on the turntable)			
– Marker light	03329492	FPL 98 CKS	
Yellow rotating beacon: (on the turntable)			
– Rotating beacon; complete	04156048		
Inside light: (in the crane cab)			
– Cab light	01207144	R10 W 24 V	10
– Reading light	00439055	P25-1 24 V	21
Spotlight, attachable: (at the front of the crane cab)			
– Filament lamp	03326694	8GS007949101	35
Spotlight, electrically adjustable: (at the front of the main boom)			
– Gas discharge lamp	03142726	8GS009028001	35

11.3 Spare parts for the carrier

Assemblies and spare parts Carrier	GROVE- Part number	Quantity, in single parts For maintenance interval				
		W	M 1	M 3	M 6	M 12
Engine						
Air filter – main filter	90025830	1 item when the symbol lights up				
Air filter – back-up filter	90025831					
Oil filter	04241344				1	
Drain plug seal	04241329				1	
Coolant cartridge	04241506					1
Fuel system						
Filter 1	04256757				1	
Filter 2	04241343				1	
Exhaust system with exhaust emission control						
AdBlue/DEF filter	04241341					1
Transfer case						
Gasket 30 x 36 Cu DIN 7603	00117151		1		1	
Gasket 16 x 20 Cu DIN 7603	00117134				1	
Axle lines Axle centre drive (for max. 14 x 8 x 14)						
Gasket 30 x 36 Cu DIN 7603	00117151		4			4
Gasket 24 x 29 Cu DIN 7603	00117145		2			4
Gasket 36 x 42 Cu DIN 7603	01371208					4
Axle lines Final drive (for max. 14 x 8 x 14)						
Gasket 24 x 29 Cu DIN 7603	00117145		8			8
Wheels						
Wheel nuts for steel rims	01207756	In case of damage; 12 each per wheel				
Wheel nuts for aluminium rims	7659100000					



Assemblies and spare parts Carrier	GROVE- Part number	Quantity, in single parts For maintenance interval					
		W	M 1	M 3	M 6	M 12	
Vehicle brake (per axle line)							
1st and 2nd axle line (duplex brake):		only in the case of wear on the drum brakes					
Brake shoe with brake lining	03322112						4
Spring	03322110						4
Brake drum	01925703						2
3rd to 7th axle line (simplex brake):							
Brake shoe with brake lining	03322121						4
Spring	02315393	4					
Brake drum	01925703	2					
Compressed air system							
Valve (if defective)	01570750	(6)					
Gasket 22 x 27 Cu DIN 7603	00117142	(6)					
Filter cartridge	04156032					1	
Hydraulic system							
Filters 1 and 2 (only clean it)	03329152			(2)			
Packing set	03135778			2			
Filters 1 and 2	03329152	at every oil change and when the symbol lights up				2	
Packing set	03135778					2	
Oil tank cover gasket 140 / 90 x 3	02313899	1 item for every oil change (if damaged)					
Ventilation filter	01576026					1	
Air-conditioning system							
Pollen filter roof air-conditioning sys. (184-192-0016 24V Aurora; cpl.)	03268376 cpl.					1	
Pollen filter heating system	02212145					1	
Other maintenance work							
Driver's cab wiper blades	02311858	(3)	(if damaged)				

Assemblies and spare parts Carrier	GROVE- Part number	Quantity, in single parts For maintenance interval				
		Y 2	Y 3	Y 5	Y 6	Y 10
Transmission						
Oil filter set with gaskets (contains two filters and one oil drain plug gasket)	03141323	1				

11.4 Spare parts for the superstructure

Assemblies and spare parts Superstructure	GROVE- Part number	Quantity, in single parts For maintenance interval				
		W	M 1	M 3	M 6	M 12
Engine						
Air filter – main filter	04256761	1 item when the symbol lights up				
Air filter – back-up filter	04256762					
Oil filter	9414101679				1	
Drain plug seal	03042029				1	
Fuel system						
Filter 1	04182148				1	
Filter 2	04182157				1	
Exhaust system with exhaust emission control						
AdBlue/DEF filter	04182142					1
Hoists						
Gasket 14 x 18 Cu DIN 7603	00117131	(2)	(if damaged)			
Gasket 18 x 22 Cu DIN 7603	00117137	(4)				
Gasket 14 x 18 Cu DIN 7603	00117131					2
Gasket 18 x 22 Cu DIN 7603	00117137					4
Gasket 26 x 31 Cu DIN 7603	00117147					4
Slewing gear						
Gasket 10 x 14 Cu DIN 7603	00117125	(3)	(if damaged)			
Gasket 10 x 14 Cu DIN 7603	00117125					3
Gasket 14 x 20 Cu DIN 7603	00117132					3
Pump transfer case						
Gasket A21 x 26 x 2	03043651		1			2

Assemblies and spare parts Superstructure	GROVE- Part number	Quantity, in single parts For maintenance interval				
		W	M 1	M 3	M 6	M 12
Hydraulic system						
Filter 1 (only clean it)	03325700			(1)		
Packing set	03135853			1		
Filter 2 (only clean it)	03317083			(1)		
Gasket	01372280			1		
Filter 1	03325700	Change the oil filter at every oil change and if a warning message is displayed.				1
Packing set	03135853					1
Filter 2	03317083					1
Gasket	01372280					1
Filter 3	04257232					1
Ventilation filter	03319602					1
Oil tank cover gasket 140 / 90 x 3	02313899	1 item for every oil change (if damaged)				
Hoist ropes						
Cover gasket for the lowering limit switch	03137794	1 (if damaged) for every rope change on the hoist				
Cable drums						
Cover gasket for cable drum 1	02313293	(if damaged)			(1)	
Cover gasket for cable drum 2	03137971				(1)	
Other maintenance work						
Windscreen wiper blade	03322652	(1)	(if damaged)			
Roof wiper blade	03322631	(1)				

Blank page

Appendix

Appendix

Table to determine the remaining theoretical service life on winch no.

Crane type:
 Work no.:
 First put into operation on:
 Winch serial number in accordance with the model plate:
 Last general overhaul performed on:
 Winch design data (see operating manual):
 Engine group:
 Load spectrum:
 Load spectrum factor:
 Theoretical service life:

Inspection interval no. (max. 1 year)	Date of first commissioning/date of inspection	Operating conditions since the last inspection	Factor of the load spectrum	Operating hours of the entire crane	Operating hours of the superstructure	Operating hours of the superstructure since the last inspection	Operating hours of the winch	Winch operating hours since the last inspection	Used proportion of theoretical service life D:	Remaining theoretical service life	Name of the expert	Signature	Comment	Name of the approved inspector	Signature
"1"			Km _i	[h]	[h]	[h]	[h]	[h]	$S_i = \frac{K m_i}{K m} \times T_i$	$D_i = D_{i-1} - S_i$					
(*)															

CAUTION:

A general overhaul is to be performed every 10 years!
 For alternative provision, refer to section 5.4.2, p. 5 - 25.

General overhaul performed on.....

- S_i = Used proportion of theoretical service life since the last inspection
- D_i = Remaining theoretical service life
- D_{i-1} = Remaining theoretical service life after the previous inspection
- Km = Factor of the load spectrum used to calculate the winch. This factor is given in the operating manual.
- Km_i = Factor of the load spectrum in the inspection interval "i" according to section 2.1
- T_i = Effective operating hours in the inspection interval "i" according to section 2.2
- (*) Copy the last line of the previous page to the following page.

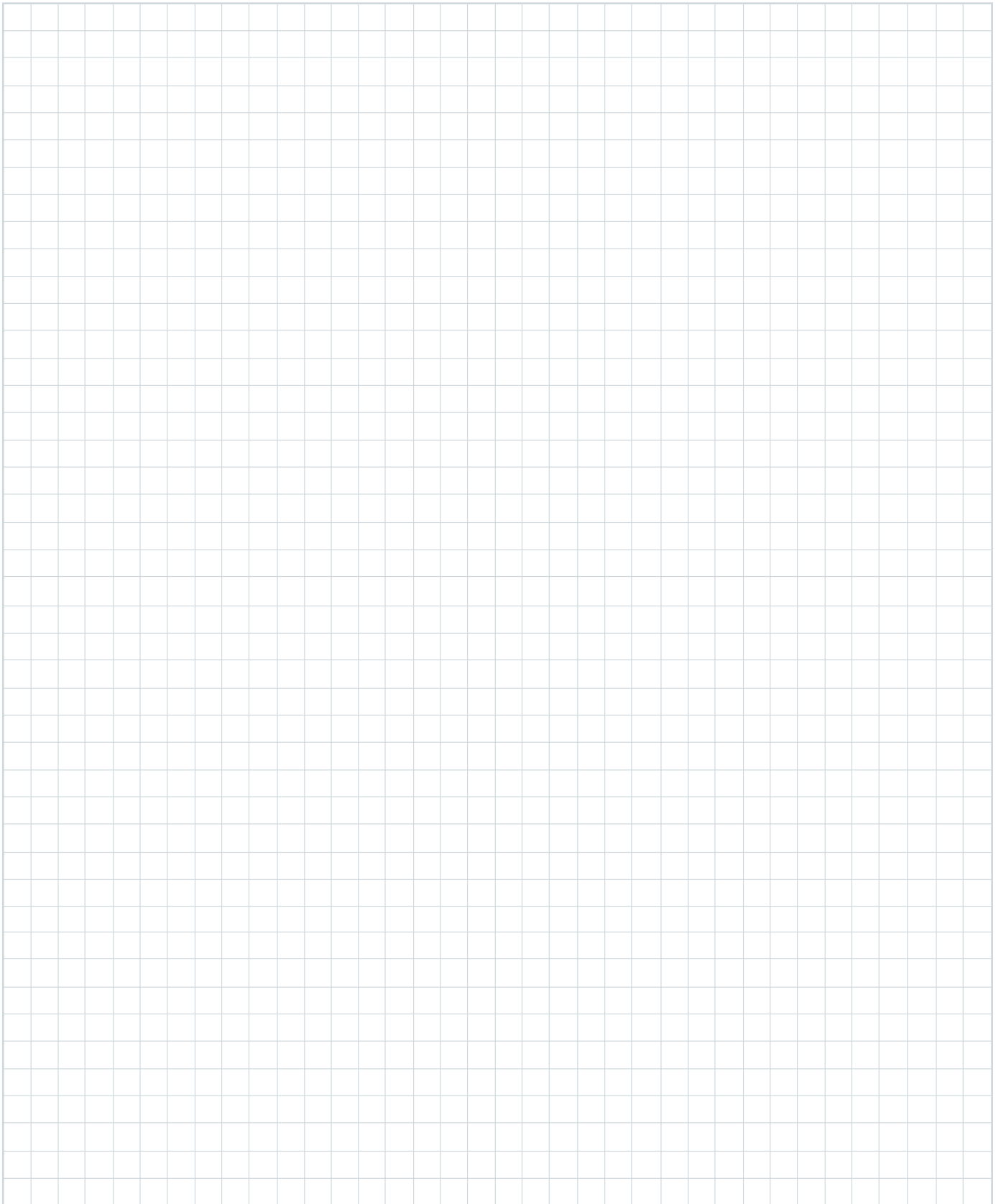

Grove

Manitowoc

National Crane

Potain



Grove

Manitowoc

National Crane

Potain

