

MLC80A-1

Product Guide

ASME B30.5
Imperial



Features

- 80 USt capacity
- 2672 ft-kips maximum load moment
- 200 ft main boom
- Max boom + fixed jib combination:
180 ft + 60 ft
- 300 hp Tier 4 Final engine
- 275 hp Tier 3 engine

MANITOWOC MLC80A-1

The MLC80A-1 provides a broad range of features that will undoubtedly be translated into jobsite benefits that increase productivity and save money.

Features

> New Cab Design

- 10% more legroom for operator
- Full high back seat with headrest and moveable riser supports operator comfortably
- Utilizes Crane Control System (CCS)
- Storage shelving located in the rear of the cab
- Redesigned consoles providing more legroom
- Left side console rotates for improved egress
- Six-way electric seat riser/slider



> Efficient Self-Assembly

- Gantry raised counterweight reduces components and maintenance
- Boom butt mounted sheaves allow for reeving assembly hook without installing boom top
- Additional boom butt mounted sheave allows for carbody counterweight installation without outside assist
- Button style wire rope terminations for easy reeving



Job site benefits

Transport and Assembly

- Designed to be transported with minimal permitted loads
- Increased hook height allows for complete self-assembly with various trailer heights
- Self Assembly sheaves in boom butt allow self-assembly without installation of boom top saving time during the assembly process

Serviceability and support

- Elimination of wireless components to reduce complexity for increased reliability
- Cummins engine, cooler, air cleaner and after treatment package allows for better serviceability
- Crane Control System (CCS) allows for troubleshooting through the control system
- Codes can be cross referenced through the Manitowoc diagnostics code app
- Supported by Manitowoc's world class dealer network



Manitowoc Crane Care when you need it.
The assurance of the world's most advanced crane service and support to get you back to work fast.



Manitowoc Finance helps you get right to work generating profits for your business.
Financial tools that help you capitalize on opportunity with solutions that fit your needs.

Contents

- Outline dimensions5
- Transport data7
- Performance data8
- Boom combinations9
- Working range/load charts - Main boom10
- Working range/ load charts - Fixed jib12
- Specifications14

Outline dimensions

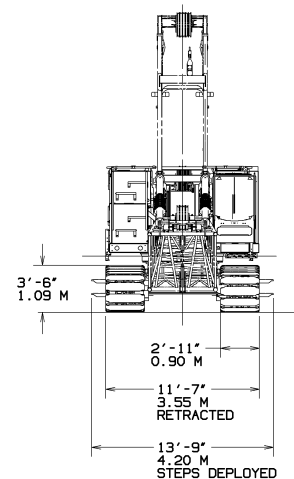
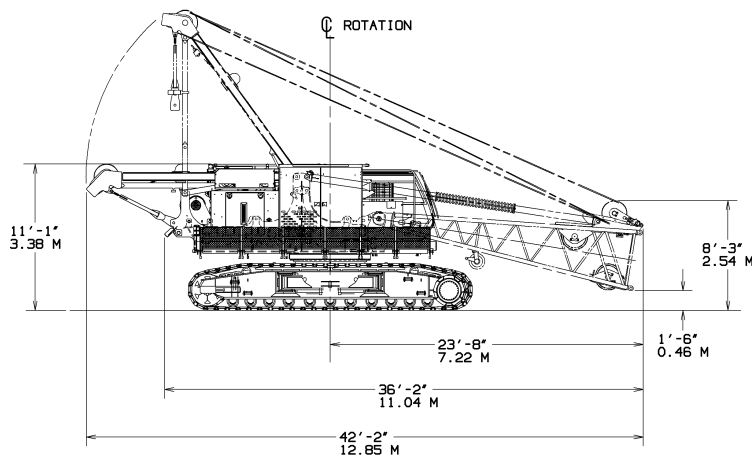
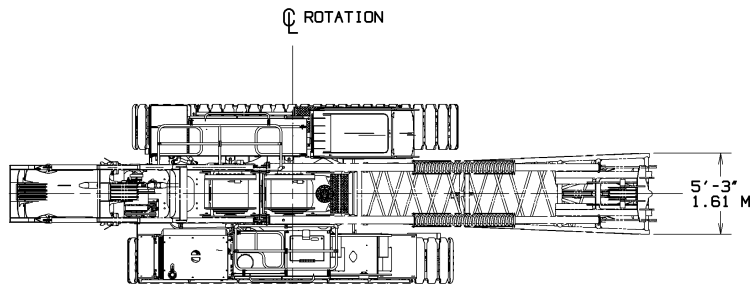
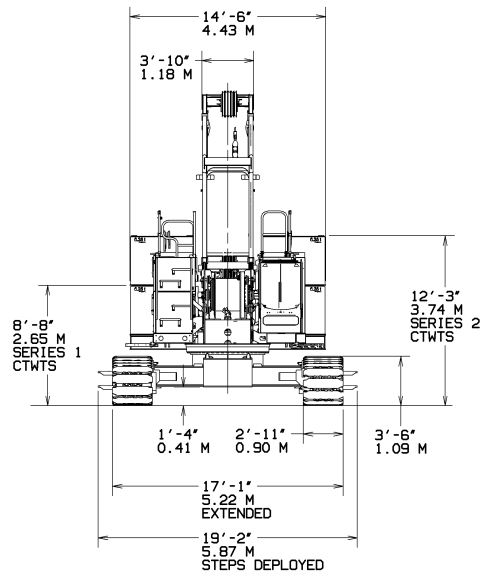
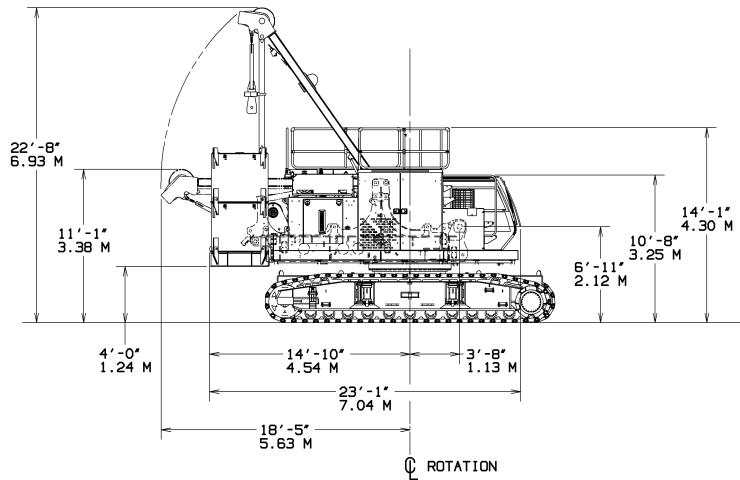
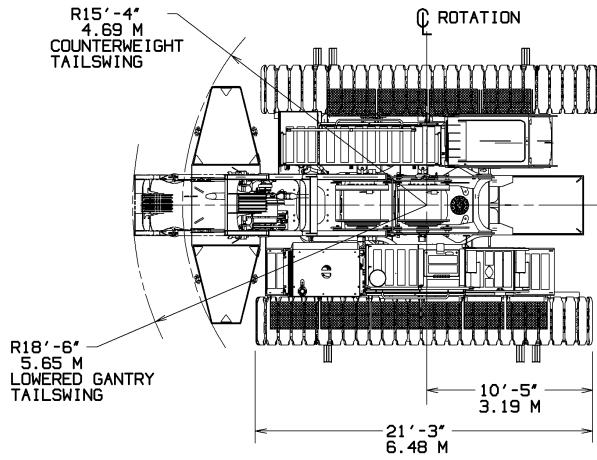

Outline dimensions

Rotating Bed w/ Boom Butt

Height	11' 2"
Length	42' 4"
Width	11' 8"
Weight	91,500 lb

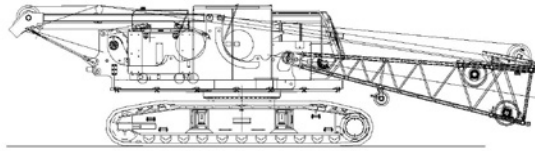

Counterweight Tray

Height	4' 5"
Length	14' 7"
Width	4' 5"
Weight	17,700 lb

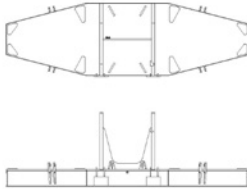

Upper Counterweight

Height	3' 11"
Length	4' 10"
Width	4' 3"
Weight	13,800 lb

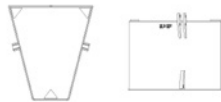

Lower Counterweight

Height	2' 5"
Length	5' 11"
Width	3' 7"
Weight	11,600 lb



7 m No. 290 Boom Top

Height	4' 11"
Length	24' 7"
Width	5' 3"
Weight	3200 lb

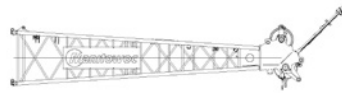

Basic Jib Assembly

Height	3' 4"
Length	32' 8"
Width	3' 1"
Weight	2000 lb



Boom Inserts				
	Height	Length	Width	Weight
3 m No. 290 Boom	4' 7"	10' 2"	5' 3"	700 lb
6 m No. 290 Boom	4' 7"	20' 0"	5' 3"	1200 lb
12 m No. 290 Boom	4' 7"	39' 8"	5' 3"	2100 lb
3 m Fixed Jib	1' 10"	10' 2"	2' 6"	170 lb

Transportation Data

Load summary						
Item	150.9 ft B10:290 Quantity on trailer load # (Does not include blocking, strapping, etc.)					
	Qty	lb	1	2	3	4
Rotating bed w/ boom butt	1	91,500	1			
Counterweight tray	1	17,700				1
Upper counterweight	4	13,800		2	1	1
Lower counterweight	2	11,600			2	
3m No. 290 boom insert	1	700		1		
6m No. 290 boom insert	1	1,200				1
12m No. 290 boom insert	2	2,100		1	1	
7m No. 290 boom top	1	3,200				1
Detachable upper boom point	1	520		1		
82.7 Ust block	1	1,550		1		
Weight ball	1	660				1
Job box	1	850			1	
Payload for each trailer (lb)			91,500	32,470	39,950	36,560

Performance data

Front and Rear Drum Linespeed				
Single line pull lb	Single line pull/single line speed ft/min			
	Layer			
	1	2	3	4
0	347	371	396	420
5,000	340	363	387	410
10,000	333	356	378	400
15,000	326	348	369	381
20,000	290	293	296	300
25,000	241	244	247	251
27,600	223	226	229	232

Third Drum Linespeed				
Single line pull lb	Single line pull/single line speed ft/min			
	Layer			
	1	2	3	4
0	284	311	337	363
5,000	275	300	324	348
8,000	270	293	316	339
11,000	256	259	261	263
14,000	207	209	211	214
17,000	175	177	179	182
20,000	152	155	157	159

Front and Rear Drum Hoist Reeving	
Parts of line	Max load (lb)
1	27,600
2	55,200
3	82,800
4	110,400
5	138,000
6	159,900

Third Drum Linepull	
Parts of line	Max load (lb)
1	20,000

Drum Spooling Capacity	
Drum	Wire rope length (working)
Front and Rear	641 ft
Third	471 ft

Boom combinations

B10:290 boom combinations

Boom length ft	Boom inserts length ft		
	9.8	19.7	39.4
62.3	0	1	0
72.2	1	1	0
82	0	0	1
91.9	1	0	1
101.7	0	1	1
111.5	1	1	1
121.4	0	0	2
131.2	1	0	2
141.1	0	1	2
150.9	1	1	2
160.8	0	0	3
170.6	1	0	3
180.4	0	1	3
190.3	1	1	3
200.1	2	1	3

No. 117 fixed jib combinations

Fixed jib length ft	Fixed jib inserts length ft
	10
30	0
40	1
50	2
60	3

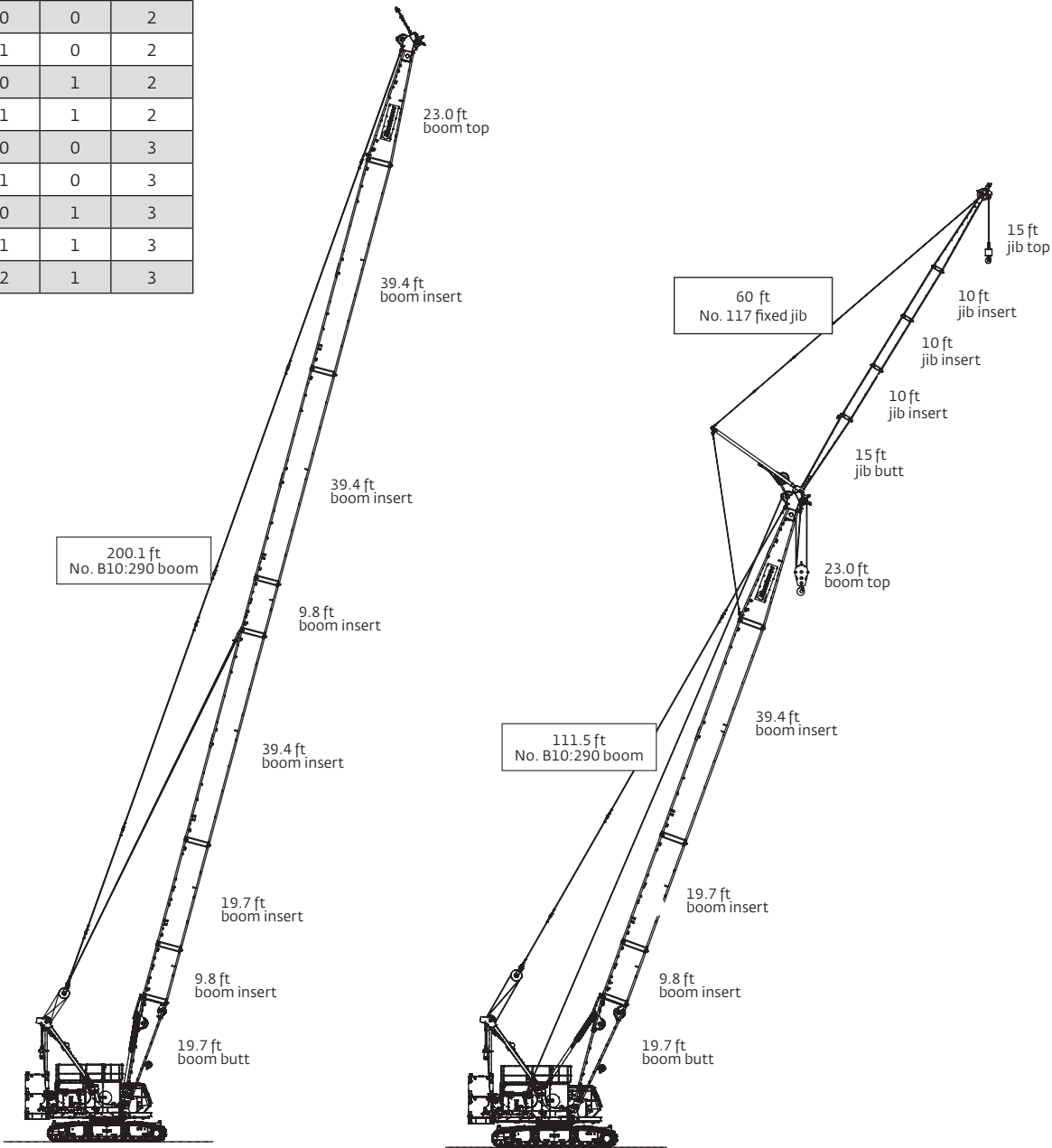

Main boom range diagram

B10:290 boom

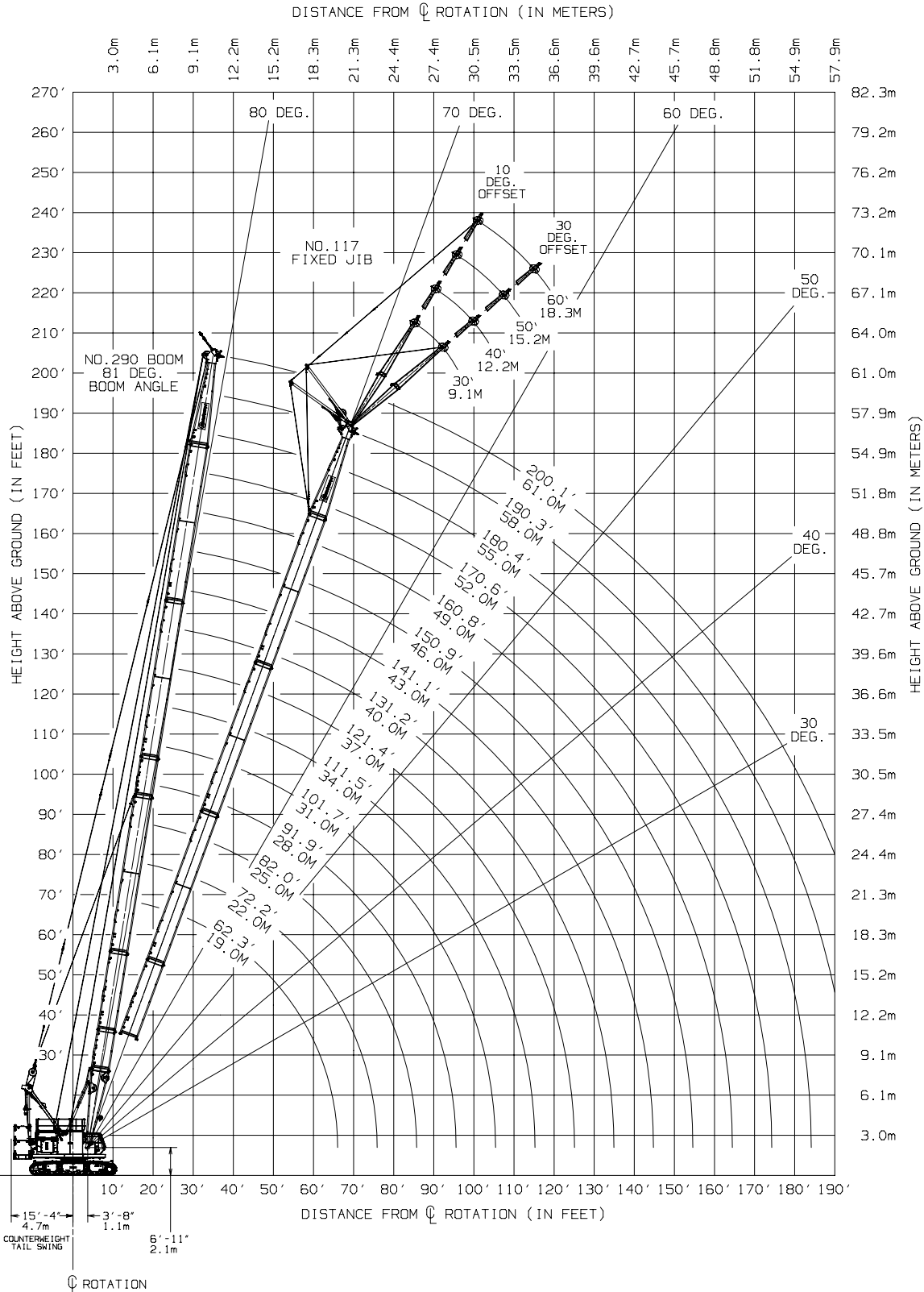
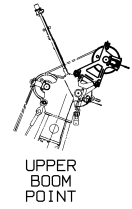

THIS CHART IS ONLY A GUIDE AND SHOULD NOT BE USED TO OPERATE THE CRANE.

The individual crane's load chart, operating instructions and other instructional plates must be read and understood prior to operating the crane

Main boom load chart

B10:290 boom

73,000 lb upper counterweight, 23,100 lb carbody counterweight

360° Radius (ft)	lb x 1000											
	Boom Length (ft)											
	62	82	92	102	112	121	131	141	151	161	180	200
16	159.9											
18	147.8	142.8										
20	133.4	133.3	126.9									
22	115.9	116.2	116.1	114.5	105.9							
24	101.4	101.6	101.6	101.5	101.4	96.1						
26	90.0	90.2	90.2	90.0	89.9	89.8	87.4					
28	80.8	81.0	80.9	80.8	80.7	80.5	80.4	77.8				
30	73.2	73.4	73.3	73.2	73.1	72.9	72.8	72.6	70.7	62.9		
34	61.5	61.6	61.6	61.4	61.3	61.1	61.0	60.8	60.6	60.4	46.0	
38	52.8	52.9	52.9	52.7	52.6	52.4	52.2	52.1	51.9	51.7	44.7	38.3
42	46.1	46.3	46.2	46.0	45.9	45.7	45.5	45.3	45.1	44.9	43.2	37.4
46	40.8	41.0	40.9	40.7	40.6	40.4	40.2	40.0	39.8	39.6	39.2	36.4
50	36.5	36.6	36.6	36.4	36.2	36.0	35.9	35.7	35.5	35.3	34.9	34.4
55	32.1	32.3	32.2	32.0	31.9	31.7	31.5	31.3	31.1	30.9	30.5	29.9
60	28.6	28.7	28.7	28.5	28.3	28.1	28.0	27.7	27.5	27.3	26.9	26.4
65		25.8	25.8	25.5	25.4	25.2	25.0	24.8	24.6	24.4	23.9	23.4
70		23.3	23.3	23.1	22.9	22.7	22.5	22.3	22.1	21.9	21.5	20.9
75		21.2	21.2	21.0	20.8	20.6	20.4	20.2	20.0	19.8	19.4	18.8
80		19.4	19.4	19.2	19.0	18.8	18.6	18.4	18.2	17.9	17.5	17.0
85			17.8	17.6	17.4	17.2	17.0	16.8	16.6	16.4	15.9	15.4
90			16.4	16.2	16.0	15.8	15.6	15.4	15.2	15.0	14.5	14.0
95				14.9	14.8	14.5	14.4	14.2	14.0	13.7	13.3	12.7
100					13.7	13.4	13.3	13.1	12.9	12.6	12.2	11.6
105					12.7	12.4	12.3	12.1	11.9	11.6	11.2	10.6
110						11.5	11.4	11.2	11.0	10.7	10.3	9.7
115						10.7	10.6	10.4	10.2	9.9	9.5	8.9
120							9.9	9.6	9.4	9.2	8.8	8.2
125							9.2	8.9	8.7	8.5	8.1	7.5
130								8.3	8.1	7.9	7.4	6.9
135								7.7	7.5	7.3	6.9	6.3
140									7.0	6.8	6.3	5.8
145									6.5	6.3	5.8	5.3
150										5.8	5.4	4.8
155										5.1	4.9	4.4
160											4.5	4.0
165											4.1	

For complete chart, refer to www.cranelibrary.com.

THIS CHART IS ONLY A GUIDE AND SHOULD NOT BE USED TO OPERATE THE CRANE.
The individual crane's load chart, operating instructions and other instructional plates must be read and understood prior to operating the crane

Fixed jib working range

J10:117 fixed jib on B10:290 boom

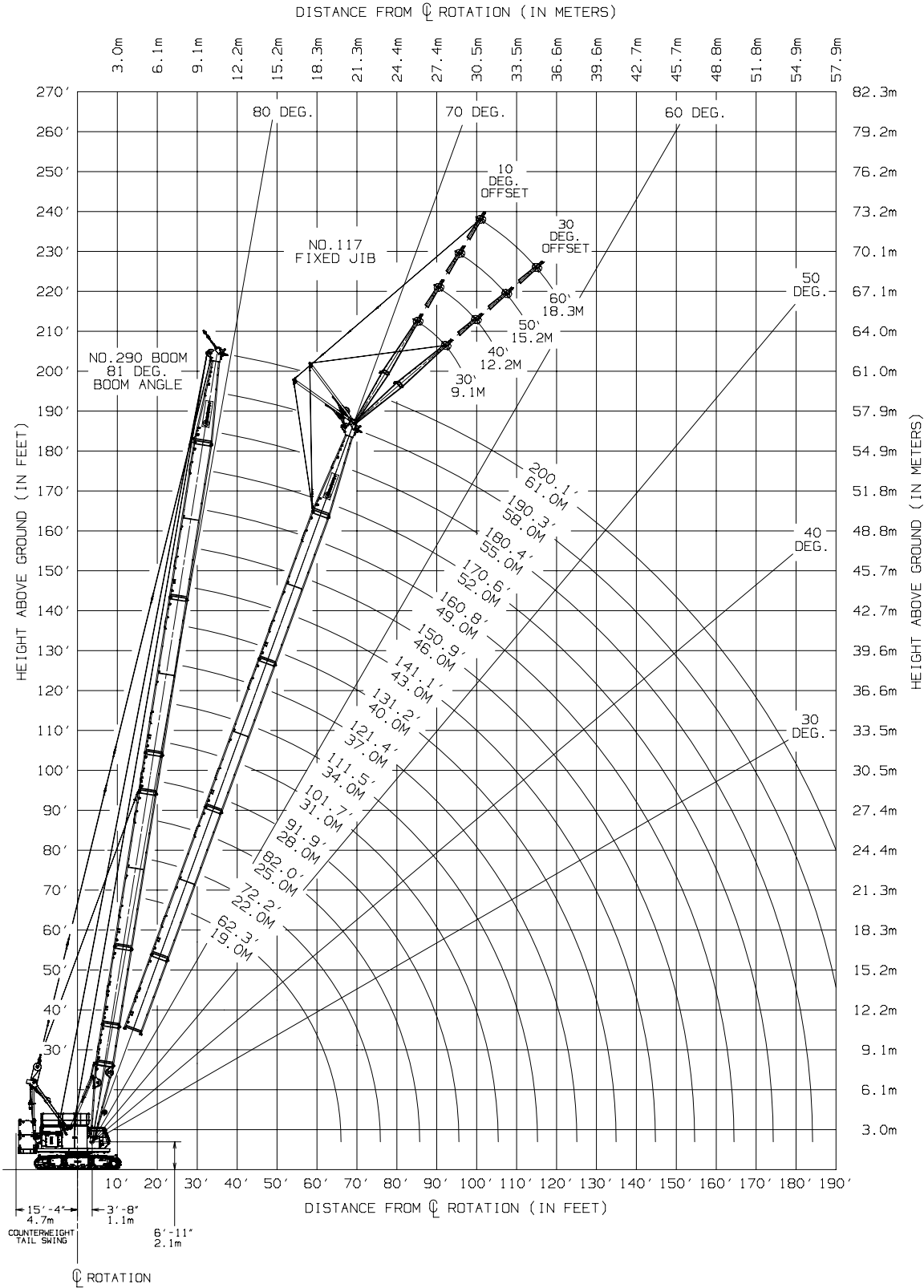
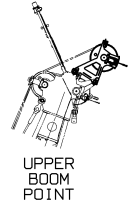

THIS CHART IS ONLY A GUIDE AND SHOULD NOT BE USED TO OPERATE THE CRANE.

The individual crane's load chart, operating instructions and other instructional plates must be read and understood prior to operating the crane

Fixed jib load chart

FJ10:117 fixed jib on B10:290 boom

73,000 lb upper counterweight, 23,100 lb carbody counterweight

360° lb x 1000

30 ft jib at 10° offset					
Radius (ft)	Boom Length (ft)				
	62	92	121	151	180
26	27.6				
30	27.6				
34	27.6	27.6			
38	27.6	27.6	27.6		
42	27.6	27.6	27.6	27.6	
46	27.6	27.6	27.6	27.6	27.6
50	27.6	27.6	27.6	27.6	27.6
60	27.2	27.6	27.6	27.4	26.7
70	23.9	23.5	22.7	22	21.3
80	20.2	19.5	18.8	18.1	17.3
90	17.1	16.5	15.8	15.1	14.3
100		14.2	13.4	12.7	12
110		12.3	11.5	10.8	10.1
120		10.6	9.9	9.3	8.5
130			8.6	7.9	7.2
140			7.5	6.8	6.1
150				5.9	5.1
160				5	4.3
170				4.2	3.5
180					2.8

40 ft jib at 10° offset					
Radius (ft)	Boom Length (ft)				
	62	92	121	151	180
30	26.5				
34	25.9				
38	25.4	25.9			
42	25	25.6	25.7		
46	24.6	25.3	25.5	25.2	
50	24.1	25	25.3	25.1	24.3
60	23.3	24.3	24.8	24.7	24.1
70	21.1	23.7	23.1	22.4	21.6
80	18.9	19.8	19.1	18.4	17.7
90	17.1	16.8	16.1	15.4	14.7
100	15	14.5	13.7	13	12.3
110		12.5	11.8	11.1	10.4
120		10.9	10.2	9.5	8.8
130		9.6	8.9	8.2	7.5
140			7.7	7.1	6.3
150			6.7	6.1	5.4
160				5.2	4.5
170				4.5	3.8
180				3.7	3.1
190					2.3

50 ft jib at 10° offset					
Radius (ft)	Boom Length (ft)				
	62	92	121	151	180
34	23				
38	22.5	22.8			
42	22.1	22.5			
46	21.7	22.2	22.3		
50	21.3	21.9	22.1	21.8	
60	20.5	21.2	21.6	21.5	20.9
70	18.3	20.7	21.1	21.1	20.7
80	16	20	19.3	18.6	17.9
90	14.3	17	16.3	15.6	14.9
100	13	14.7	13.9	13.2	12.5
110	12.2	12.7	12	11.3	10.6
120		11.1	10.4	9.7	9
130		9.8	9.1	8.4	7.7
140		8.6	7.9	7.3	6.5
150			6.9	6.3	5.5
160			6.1	5.4	4.7
170				4.7	3.9
180				4	3.3
190				3.2	2.7

60 ft jib at 10° offset					
Radius (ft)	Boom Length (ft)				
	62	92	121	151	180
38	20.3				
42	20	20.2			
46	19.6	19.9	19.9		
50	19.3	19.7	19.7	19.4	
60	18.4	19	19.2	19	17.5
70	16.8	18.4	18.7	18.7	17.1
80	14.6	17.8	18.3	18.3	16.8
90	12.8	17.1	16.4	15.7	15
100	11.5	14.8	14	13.4	12.6
110	10.4	12.9	12.1	11.4	10.7
120	9.8	11.3	10.5	9.8	9.1
130		10	9.2	8.5	7.8
140		8.8	8.1	7.4	6.7
150		7.7	7.1	6.4	5.7
160			6.2	5.6	4.8
170			5.5	4.8	4.1
180				4.1	3.4
190				3.5	2.8
200				2.7	2.1

THIS CHART IS ONLY A GUIDE AND SHOULD NOT BE USED TO OPERATE THE CRANE.

Manitowoc MLC80A-1 The individual crane's load chart, operating instructions and other instructional plates must be read and understood prior to operating the crane

Specifications

Upperworks

Engine

Cummins Model QSB6.7 Tier 4 Final (Stage IV), 6 cylinder diesel, 300 hp (223 kW) at 2100 governed RPM.

Cummins Model QSB6.7 Tier 3 (Stage III), 6 cylinder diesel, 275 hp (205 kW) at 2100 governed RPM.

Includes exhaust aftertreatment system (Tier 4 Final) or muffler (Tier 3), air cleaner, 70 amp alternator, radiator and fan. Also includes 100 gallon (378 liter) capacity diesel fuel tank, mounted on right side of upperworks.

Crane Control System

The Crane Control System (CCS) offers a user-friendly interface, two full graphic displays mounted vertically for better visibility, a jog dial for easier data input and ergonomic joysticks. Block-up limit control is standard for hoist and whip lines. Travel and swing alarms are standard. RCL/RCI (Rated Capacity Limiter/Rated Capacity Indicator) system is standard.

Hydraulic system

Three high-pressure pumps are driven by the engine. Two pumps provide “open loop” hydraulic power enabling simultaneous multi-function capability. One pump provides independent “closed loop” hydraulic power for the swing system. An additional pump provides hydraulic power for the cooler fan and an additional pump is included with free fall.

Hydraulic reservoir capacity is 83 gallon (314 liter) and is equipped with breather, sight and electrical level indicator, clean out access, and internal diffuser. Replaceable, full flow tank filters are furnished in the hydraulic circuit. All oil is filtered prior to return to the hydraulic reservoir. Hydraulic system also includes hydraulic oil cooler.

Drums

Two 22 inch width drums are driven by independent variable displacement axial piston hydraulic motors through planetary reduction. Drums are grooved for 26 mm rope and mounted in rotating bed. Powered hoisting/lowering operation is standard with automatic (spring applied, hydraulically released) multi-disc brakes, and drum rotation indicators.

- Optional: free-fall operation for front and/or rear drums.
- Optional: auxiliary (third) hydraulic powered drum mounted in rotating bed. Drum is grooved for 26 mm rope. Includes all hydraulic and electrical components to equip drum.

Boom hoist

Independent boom hoist consists of a single drum grooved for 0.75 inch diameter wire rope. Includes 0.75 inch diameter wire rope for boom hoist reeving. Drum is powered by a fixed displacement hydraulic motor coupled to an internal brake and planetary gearbox equipped with ratchet and pawl.

Gantry

The 8 part boom hoist reeving is reeved between the 5 sheave gantry and 4 sheave equalizer, with the dead end on the gantry. When used with optional self-erect sheave in the boom butt the machine is capable of installing carbody counterweights, stacking the upperworks counterweights and assembling the boom and jib. The gantry is also utilized to lift the entire upperworks counterweight assembly into place, controlled by remote control.

Counterweight

The upperworks counterweight is attached to rotating bed with remote controlled hydraulically actuated pins. The upperworks counterweight consists of a one-piece tray and four upper counterweight boxes. Carbody counterweight boxes are each attached to carbody.

Series 1

Upper counterweight (2 pieces+tray) 45,450 lb

Series 2

Upper counterweight (4 pieces+tray) 73,020 lb

Carbody counterweight (2 pieces) 23,150 lb

Total counterweight 96,170 lb

Swing system

Independent single swing drive mounted in rotating bed is powered by a hydraulic motor driving a spur gear through a planetary reduction with internal brake.

Maximum swing speed: 2.5 rpm.

- Optional: electronic swing position indicator and swing limiter

Operator's cab

New wider cab provides 10% increased operator legroom. Fully enclosed and galvaneled steel insulated module is equipped with sliding door, large safety glass windows on all sides and roof. Signal horn, cab space heater, front and roof windshield wipers, air conditioning, dome light, sun visor and shade, fire extinguisher and air circulating fan are standard.

- Optional: External RCI light, electronic level indicator, radio and camera system.

Lowerworks

Carbody

High strength fabricated steel assembly utilizing swing away carbody beams and two hydraulic cylinders for extending and retracting of crawlers.

Crawlers

Crawler assemblies are 21' 3" (6.5 m) long, high strength steel fabrications with 3' (0.9 m) wide cast steel crawler pads. Each crawler is powered independently by a variable displacement hydraulic motor driving a planetary reduction. Crawlers provide ample tractive effort that allows counter rotation with full rated load. Maximum ground speed of 1.6 mph. (2.6 km/hr).

Attachments

No. 290 boom

The liftcrane is equipped with a 62' 4" (19 m) basic No. 290 tubular chord boom consisting of a 19' 8" (6 m) butt, a 19' 8" (6 m) boom insert and 23' (7 m) top with three 25.6" diameter roller bearing sheaves. No. 290 boom utilizes wire rope pendants. Boom butt has incorporated equalizer rails for connecting to equalizer to boom butt, boom butt also remains installed for transportation.

Spring cushioned boom stop and electronic automatic boom stop standard.

- Optional: No. 290 boom lengths are increased using 9' 10" (3 m), 19' 8" (6 m), and 39' 4" (12 m) boom inserts with wire rope pendants. Max boom length is 200.1' (61 m).

No. 117 fixed jib

30' (9.1 m) basic No. 117 tubular chord fixed jib consisting of 15' (4.6 m) jib butt and 15' (4.6 m) jib top with 17' 11" (5.5 m) jib strut, and wire rope, pendants. Includes RCL/RCI hardware.

- Optional: No. 117 fixed jib lengths are increased using 10' (3 m) inserts with wire rope pendants. Max fixed jib length is 60' (18.3 m).

Specifications

Optional equipment

Detachable upper boom point with one 24 in diameter tapered roller bearing sheave for No. 290 boom top

Blocks and hooks –

- 13.8 USt (12.5 mT) cylindrical weight ball with swivel hook.
- 27.5 USt (25mT) hook block with one 24 in sheaves for 26 mm wire rope with swivel hook and hook latch.
- 82.7 USt (75 mT) hook block with three 24 in sheaves for 26 mm wire rope with swivel hook and hook latch.
- 110.2 USt (100 mT) hook block with four 24 in sheaves for 26 mm wire rope with swivel hook and hook latch.

Hydraulic Test Kit: recommended to properly analyze the performance of the hydraulic system.

Service Interval Kits including the items necessary to perform general scheduled maintenance, available through Crane Care.

Special Paint Color (other than Manitowoc standard red and black.)

Special Customer Decals: custom vinyl decal(s) of name and/or logo from artwork supplied by customer.

Export Packaging: basic crane, boom and jib sections.

Notes

Maniowoc Cranes

Regional headquarters

Americas

Maniowoc, Wisconsin, USA
Tel: +1 920 684 6621

Shady Grove, Pennsylvania, USA
Tel: +1 717 597 8121

Europe, Middle East, Africa

Ecully, France
Tel: +33 (0)4 72 18 20 20

China

Shanghai, China
Tel: +86 21 6457 0066

Greater Asia-Pacific

Singapore
Tel: +65 6264 1188



Maniowoc Crane Care when you need it.

The assurance of the world's most advanced crane service and support to get you back to work fast.



Maniowoc Finance helps you get right to work generating profits for your business.

Financial tools that help you capitalize on opportunity with solutions that fit your needs.

This document is non-contractual. Constant improvement and engineering progress make it necessary that we reserve the right to make specification, equipment, and price changes without notice. Illustrations shown may include optional equipment and accessories and may not include all standard equipment.