

ROTATING UPPERWORKS WEIGHT AND CENTER OF GRAVITY (WU)			
EQUIPPED AS	WEIGHT (lbs)	DIM "A" (in.)	DIM "B" (in.)
14000 SERIES 1 (127,000 lb. CTWT)	190.717	138.5	-0.7
14000 SERIES 2 (168,000 lb. CTWT)	231.661	145.8	-5.2
14000 SERIES 3 (178,000 lb. CTWT)	241.661	147.3	-7.3
LOWERWORKS WEIGHT AND CENTER OF GRAVITY (WL)			
EQUIPPED AS	WEIGHT (lbs)	DIM "C" (in.)	DIM "D" (in.)
14000 SERIES 1	95.808	0	-74.0
14000 SERIES 1 - WITH OPTIONAL CARBODY JACKS	98.417	0	-73.8
14000 SERIES 2	148.934	0	-72.2
14000 SERIES 2 - WITH OPTIONAL CARBODY JACKS	151.543	0	-72.1
14000 SERIES 3	166.434	0	-72.1
14000 SERIES 3 - WITH OPTIONAL CARBODY JACKS	169.043	0	-72.0

BOOM WEIGHTS		
BOOM LENGTH (ft.)	#76	
	WBB (lbs)	WBT (lbs)
65.5	12,754	15,000
75.5	13,901	15,557
85.5	14,978	16,189
95.1	15,752	16,485
105.0	16,768	17,180
114.8	17,438	17,587
124.7	18,192	17,929
134.5	18,814	18,386
144.4	19,802	19,110
154.2	20,377	19,616
164.0	20,972	20,010
173.9	21,536	20,528
183.7	22,526	21,250
193.6	23,060	21,799
203.4	23,598	22,252
213.2	24,132	22,803
223.1	25,330	23,743
232.9	25,834	23,482
242.8	26,329	23,980
252.6	26,837	24,557
262.5	27,834	25,272
272.3	28,390	25,798
282.1	28,863	26,320
292.0	29,359	26,909

NOTE 1: BOOM AND JIB WEIGHTS INCLUDE WEIGHT OF BOOM, JIB, PENDANTS ETC.; BUT DO NOT INCLUDE WEIGHT OF LOAD, LOAD BLOCK, WEIGHT BALL, SLINGS, ETC. ALL ITEMS SUSPENDED FROM BOOM OR JIB MUST BE CONSIDERED PART OF THE LOAD.

NOTE 2: FOR #76 BOOM ONLY, WEIGHTS FOR 65.5 THRU 223.1 FT. BOOMS INCLUDE A 7 SHEAVE BOOM POINT, 232.9 FT THRU 292 FT BOOM INCLUDES A 2 SHEAVE BOOM POINT.

NOTE 3: CONSULT PROPER CRANE CAPACITY CHART FOR LIFTING CAPACITIES AND ALLOWABLE BOOM AND JIB COMBINATIONS.

CAUTION: NOT TO BE USED FOR CRANE RATING PURPOSES.

#134 JIB WEIGHTS		
LENGTH (ft.)	WJB (lbs)	WJT (lbs)
30	2,300	1,080
40	2,589	1,322
50	2,871	1,573
60	3,150	1,828
70	3,427	2,085
80	3,701	2,343

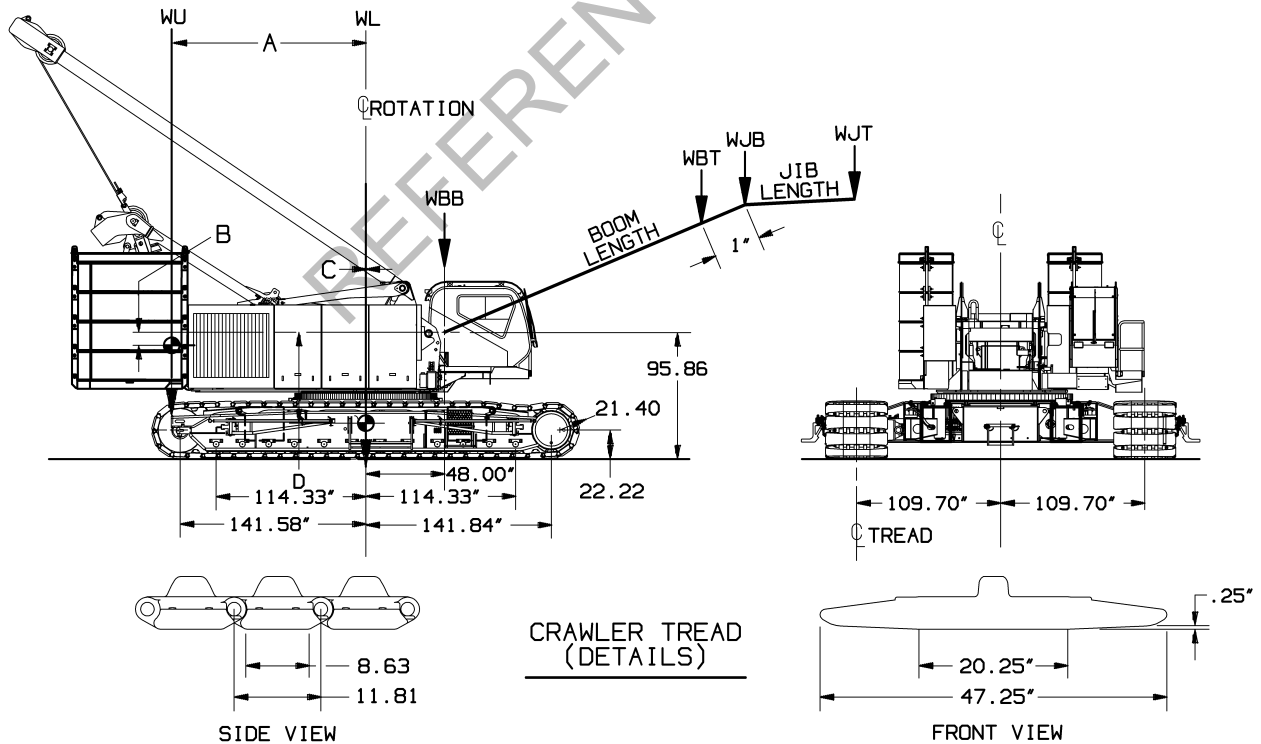

DATE 11-13-20	SCALE NONE	MANITOWOC CRANES, INC. MANITOWOC, WISCONSIN	C G CHART
DWG. NO. T.S. 341	DR. JLD		48" TREADS
	CK. JLD	MODEL 14000	BOOM NO.76
	APP.		FIXED JIB NO. 134