

**POTAIN®**

## Igo T range

**CRANES THAT MEET YOUR REQUIREMENTS!**







## Igo T range





### Cranes that meet your requirements!

The 3 models **Igo T 70 A**, **Igo T 85 A** and **Igo T 130** are telescopic, automatic erection cranes, with a high lifting capability. They help your day-to-day construction work on the most demanding sites.

Igo T cranes are suitable for all sites, due to their variable height and various jib configurations.

The simple and quick erection requires very little ground area, as the jib is unfolded from the top.

- > Proven transport solutions,
- > Quick and safe erection,
- > Very adaptable to site configuration,
- > Operator comfort.

Igo T				 m												
	m	m	t	28,5	30	30,5	31	31,7	33,5	33,8	35	40	42	45	47	50
Igo T 70 A	4,5	35	4	2,5		2,2					1,85	1,45				
Igo T 85 A	4,5	38	6					2,75		2,5		1,8		1,4		
Igo T 130	5	37,3	8							3,9			2,25		1,7	1,4



## Proven transport solutions

Igo T cranes use standard transport axles that are shared between the entire GMA Potain range: one set of axles can be used for several types of crane.

10 km/h, 25 km/h and 80 km/h transport systems are available to resolve the various problems involved in routing to work sites.

- ✓ Igo T 85 A on a trailer  
Transport axles DJ105/S125



> Igo T cranes can be transported:

- on a trailer
- by an articulated truck

The steerable rear axle S125D, available on the Igo T 70 A and Igo T 85 A further enhances their on-site manoeuvrability.

The compact nature of the transport equipment together with optimum ground clearance, facilitate access, even over rough ground.

- ▼ Igo T 130 on an articulated truck  
Transport equipment SL122/J215M.







## Quick and safe erection

Their hydraulic technology allows Igo T cranes to be erected quickly and without effort.

**Each phase of the erection is made safe by sensors that minimise manual action and prevent operating errors.**

## > Exclusive erection kinematics: space management

The entire erection requires very little space:

- Telescopic action with the jib along the mast limits the ground area required to the size of the transport convoy.
- Unfolding the jib from the top avoids any obstacles that may be present on the site.

Radio-controlled erection gives the erection technician excellent visibility whilst extending the machine.

## > Jib raising configurations

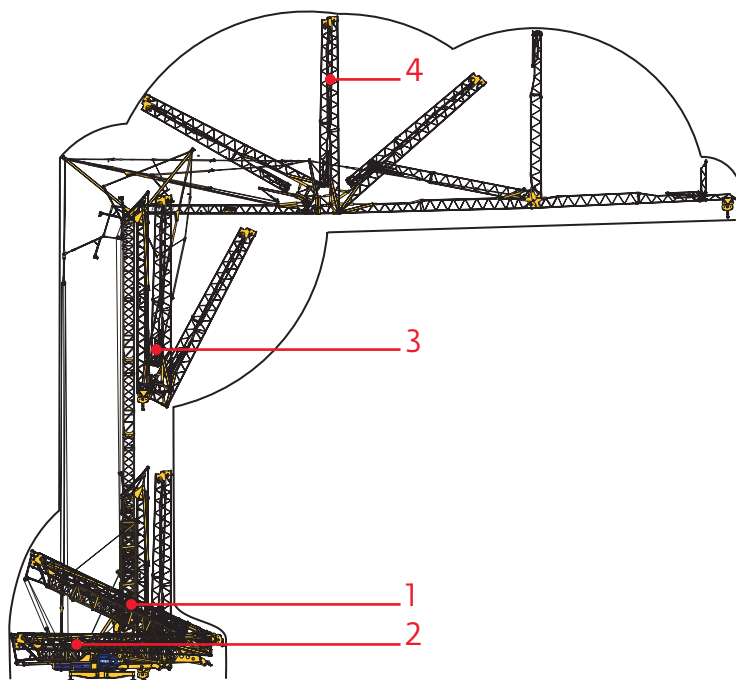

Raising the jib after telescoping

< Igo T 70 A  
Igo T 85 A  
Igo T 130

- < 1 - Raising the mast
- 2 - Ballasting
- 3 - Telescoping
- 4 - Unfolding the jib

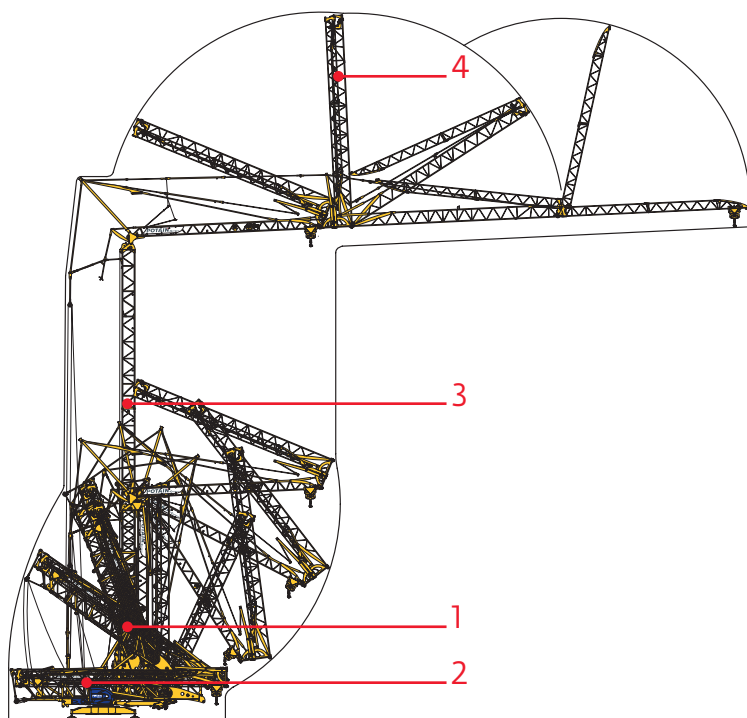

Raising the jib before telescoping

< Igo T 70 A  
Igo T 85 A

- < 1 - Raising the mast
- 2 - Ballasting
- 3 - Telescoping
- 4 - Unfolding the jib



## > Raising the mast

The mast is raised by a radio-controlled hydraulic cylinder.  
A simple and quick action for the erection operator.

## > Ballasting with the derrick

The hydraulic derrick allows the user to ballast the crane with no auxiliary lifting equipment, allowing the user more independence.

### ∨ Hydraulic raising of the mast



### ∨ Independent ballasting







## > Telescoping

Igo T cranes offer considerable erection time-saving, particularly during the telescoping phase. Each 6 m extension mast is assembled and locked simply, without effort and in complete safety.

- Patented locking system
- Telescoping system integral with crane

Shared format of the extension masts for the Igo T 70 A and Igo T 85 A.

Igo T 130 extension masts can be used on the Igo T 70 A and 85 A, with an adapter.

The cost of ownership of the machines is reduced.

^ Telescoping by insertion of extension mast



^ Patented locking system

## > Unfolding the jib

- Unfolding the jib from the top is radio-controlled. This automatic sequence is powered by hydraulic cylinders and makes the operation simple and quick.

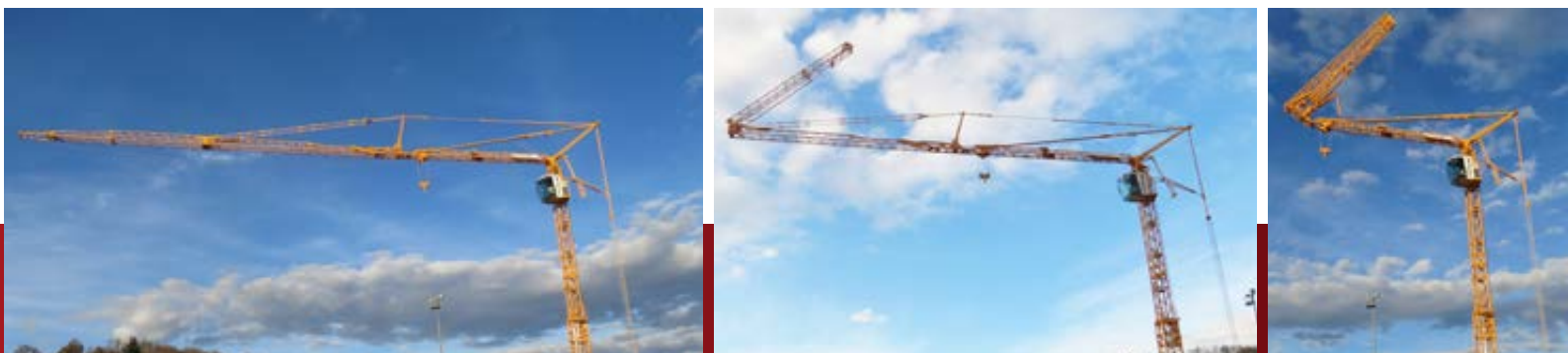

The image shows a construction site with two large red tower cranes. One crane is on the left, and another is on the right. In the background, a multi-story building is under construction, with some floors showing concrete and others showing wooden formwork. The sky is blue with some clouds. The text 'Performance on operation site' is written in red in the upper left quadrant.

## Performance on operation site

By combining raised jib and extension masts, the Igo T cranes go even higher:

Igo T 70 A : 44,5 m

Igo T 85 A : 51 m

Igo T-130 : 61 m

CALIFORNIA

PENTA  
LAS AMERICAS



## > Many jib configurations

The Igo T 70 A, Igo T 85 A and Igo T 130 have maximum jib lengths of 40 m, 45 m and 50 m, respectively, thus offering many possible working configurations.

- The horizontal jib position, aligned or folded.
- The many short jib configurations allow higher peak loads.
- Raising the jib to 30° allows greater heights to be reached, while still retaining an excellent load curve.

## > Variable working heights

Several working heights are available as standard (without extension mast).

5 supplementary working heights may be obtained by inserting 3 extension masts of 6 m. With adjustment possible every 3 m, the Igo T can be modified and adapted to the height of each work site.



< Working with folded jib

## User comfort

### > Cabs, comfort and productivity (options)

Igo T cranes are operated either by radio-control or from a cab.

The Ultra View cab and the 800 cab are available on all the Igo T models.

The Ultra View cab is very spacious, has a very ergonomic design and offers a panoramic view, thus providing optimum working conditions for the operator.





## > Radio-control

The radio-control facility allows the operator complete freedom to control the crane from the ground during the slinging operations. The ergonomic design is easy to handle and the screen permanently displays essential information: height, suspended load, jib radius, moment and wind speed.



< Dynamic operator aid with indication of load/jib radius values compared with the maximum authorised values.

## > Control system

The SmartCom onboard control system allows control in complete safety and a fast start-up for the crane. It also offers maintenance and diagnostic aid. Options such as the zone limitation system are easily connected.



^ Basic version supplied with an auxiliary control unit.  
Integral combination unit optional.

## > Mechanisms

The frequency variation mechanisms provide very smooth and progressive movement and extremely precise control.

For slewing, the operator can select a control profile as a function of the work to be carried out (broad movement amplitude or precision).

For the Igo T 85 A and the Igo T 130, the frequency variation rail travelling mechanism is available, with the bogies remaining mounted on the crane for transport.



^ New: Igo T 130 rail travelling.



# Technologies

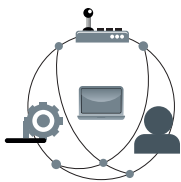

## > SmartCom (Igo T 70 A - Igo T 85 A - Igo T 130)

The SmartCom onboard control system centralises the control actions input by the operator and controls the various movements. It also manages the safety systems during the work phases and helps the technician during the erection operations.

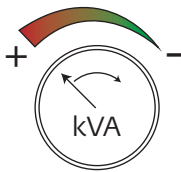

## > Power Control (Igo T 130)

The crane is compatible with the electrical power supply available on site. In case of a low power system or a generator, the required power output can be easily adjusted through a parameter in the crane control system.

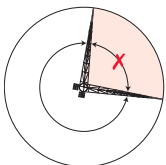

## > Top Zone (Igo T 70 A - Igo T 85 A - Igo T 130)

All Igo T cranes can be equipped, as an option, with our zone limitation system. The system is easy to install and use, and prevents working over public buildings, schools, railway lines, overhead power lines, etc.

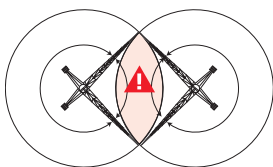

## > Top Tracing 2 (Igo T 70 A - Igo T 85 A - Igo T 130)

The Top Tracing 2 anti-collision system is available as an option on the Igo T range. This system manages the risk of collision between cranes.



## > Centralised lubrication system (Igo T 70 A - Igo T 85 A - Igo T 130)

The centralised lubrication of the slewing ring automatically and regularly lubricates both the inside of the ring and the outer drive teeth. This system is an ideal means of extending the life cycle of the ring.





# The Manitowoc Company, Inc.

## Regional headquarters

### Americas

Milwaukee, Wisconsin, USA

Tel: +1 414 760 4600

Shady Grove, Pennsylvania, USA

Tel: +1 717 597 8121

### Europe and Africa

Dardilly, France - TOWERS

Tel: +33 (0) 4 72 18 20 20

Wilhelmshaven, Germany - MOBILE

Tel: +49 (0) 4421 294 0

### APAC

Shanghai, China

Tel: +86 21 6457 0066

Singapore

Tel: +65 6264 1188

### Middle East and India

Dubai, UAE

Tel: +971 4 8862677

This document is non-contractual. Constant improvement and engineering progress make it necessary that we reserve the right to make specification, equipment, and price changes without notice. Illustrations shown may include optional equipment and accessories and may not include all standard equipment.

