

Potain Igo T 70 A

Product Guide



Features

- 4000 kg (8818 lb) maximum capacity
- 1450 kg (3197 lb) capacity at 40 m (131 ft)
- 40 m (131 ft) maximum operating hook radius
- 44,5 m (146 ft) maximum hook height with jib set at 30°
- 35 m (115 ft) maximum hook height with jib horizontal
- Variable height mast from 15 m (49 ft) to 35 m (115 ft) with optional mast inserts

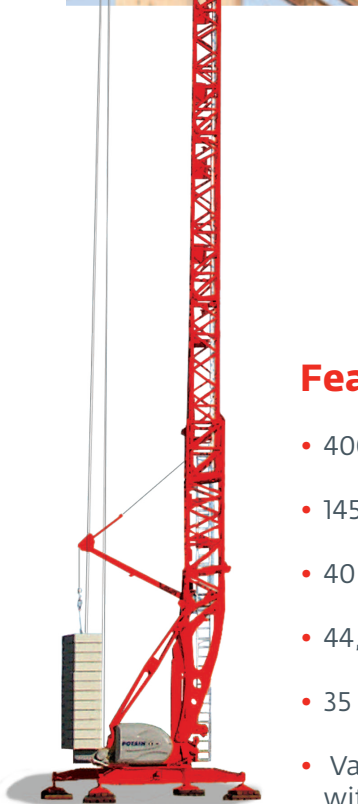

Features



Mast inserts

Increase your working height by up to 15 m (49 ft) with optional mast inserts. Each insert is 6 m (20 ft) and provides the operator with additional heights under hook.

SmartCom technology

SmartCom is an embedded control system in CAN bus network which is based on a man to machine interface located in the control panel. This electronic system offers various functionalities which make putting the crane into service, as well as controlling the safety devices, faster and easier and makes crane maintenance easier than ever.

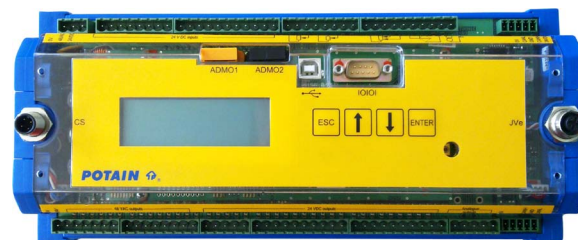

Cab

Two cab options are available for the Igo T 70 A: the Ultra View cab is equipped with integrated controls and provides maximum operator comforts; the Cab 800 provides operators with an areal view and offers basic comforts.



North American Highway Axle

Simplify road transport with the North American Highway Axle and adaptation kit 203. Multiple pin positions for optimal weight distribution, DOT compliance and an optional attachable 3rd axle make this an ideal solution for your transportation needs.

Contents

Features	2
Specifications	4
Transport	5
Weights	6
Dimensions	7
Crane profile & working range	8
Load charts	9
Mechanisms	10
Metric dimensions	11
Metric crane profile	12
Metric load charts	13
Metric mechanisms	14
Symbols glossary	15

Specifications



Jib

40 m (131 ft) radius standard offsettable lattice jib. Jib can be offset to 30°. Opening and aligning are carried out automatically by three hydraulic cylinders.



Mast

Telescoping lattice mast is made vertical by one hydraulic cylinder. Hook heights of 15 m (49 ft), 17 m (56 ft), and 20 m (66 ft) achievable with standard mast. 360° rotation possible during raising sequence.



*Optional mast inserts

Three 6 m (20 ft) mast inserts available to reach a maximum hook height of 35 m (115 ft). Increasing mast height with one insert provides hook heights of 23 m (75 ft) and 26 m (85 ft); second mast insert provides hook heights of 29 m (95 ft) and 32 m (105 ft); third mast insert provides hook height of 35 m (115 ft).



Chassis

Outriggers swing and lock into position. 4,5 m (14.8 ft) square outrigger spread with 2,7 m (8.9 ft) slewing radius. Outrigger pads are stowed on the crane during transport (600 mm x 600 mm [23.6 in x 23.6 in]).



*Ballast

Ballast requirement for the crane consists of, at minimum, 15 slabs each weighing 2200 kg (4850 lb). An additional slab is required if cab is mounted as well as another if mast insert(s) is used. Maximum counterweight is permissible in all configurations except when forbidden, please consult the crane's manual for details.



*Optional hydraulic ballasting derrick

Removable and able to be used on other Igo T 70 A units, the hydraulic ballasting derrick uses the hoisting winch and is controlled by the remote control.



Electrical requirement

480 volt, 60 Hz measured at the turntable. Earth rod and electric cable stowed on the crane during transport.



Reeving

SM/DM block for 2 (SM) or 4-part line (DM). Manual removal of one pin to change between SM and DM. Pure SM1 (section of hook block removed) is possible with gain of 100 kg (220 lb) lifting capacity.



Hydraulic equipment

Hydraulic cylinders are used for raising the mast, unfolding the jib, and slewing the derrick. All actions are carried about by the remote control.



Controls

Wireless remote control provides information to the operator about wind speed, radius, hook height, load, and moment. Lights and buzzers alert the operator when nearing limits of operation. Battery charger and extra battery are provided with crane.

Auxiliary remote attached by tethered cord ensures continual operation in case of battery or other malfunction of the wireless remote control.



Anemometer

Electronic wind speed meter to alert the operator of wind speed conditions. Provides selective display on the radio remote. Maximum in service wind speed is 72 km/h (45 mph) and maximum out of service wind speed is 150 km/h (93 mph).



Swing

RVF 151 Optima +: slewing mechanism with maximum swing speed of 0.8 rpm. Progressive control of speed with counter-slewing possible, anti-load swinging system makes aligning the load with the jib easier. Multiple rpm speeds possible depending upon parameter selected.



Hoist

15 LVF 11 Optima: 15 hp variable frequency hoist with 1.1 t (1.2 USt) line pull. 3 notch, progressive speed change according to the accelerating or decelerating ramps. Optima allows the hoist to adapt its speed to the weight of the load.



Trolley

3 DVF 5: 3 hp variable frequency hoist with 500 kg (1102 lb) line pull. Three (3) notch winch, progressive speed change according to acceleration or deceleration ramps controlled by the frequency converter.



*Optional transport axle sets

Axle sets are available for both jobsite and highway applications. Jobsite axles are rated at either 10 km/h (6 mph) or 25 km/h (15.5 mph); highway axle set is rated at 80 km/h (50 mph).

*Optional equipment

- STANDARD NORTH AMERICAN SPECIFICATION: includes offsettable jib, pre-equipment for interference system, three mast inserts, Top Zone and sixteen (16) slabs of counterweight.
- Mast inserts 6 m (20 ft)
- Fixed height cab (Ultra View or Cab 800)
- Access ladders
- Transport axles and kits
- Top Zone
- Top Tracing

Consult price list for additional options

DJ100 / S120 10 km/h (6 mph)

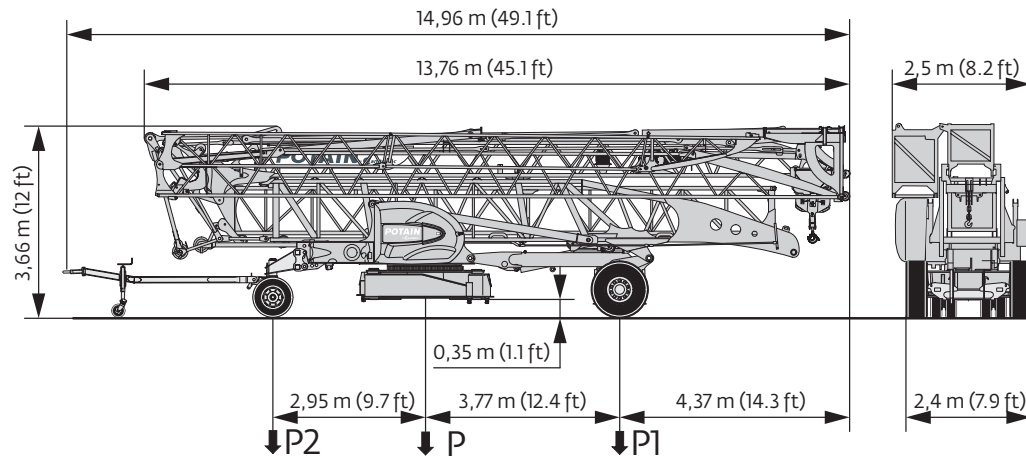

DJ105 / S125 25 km/h (16 mph)

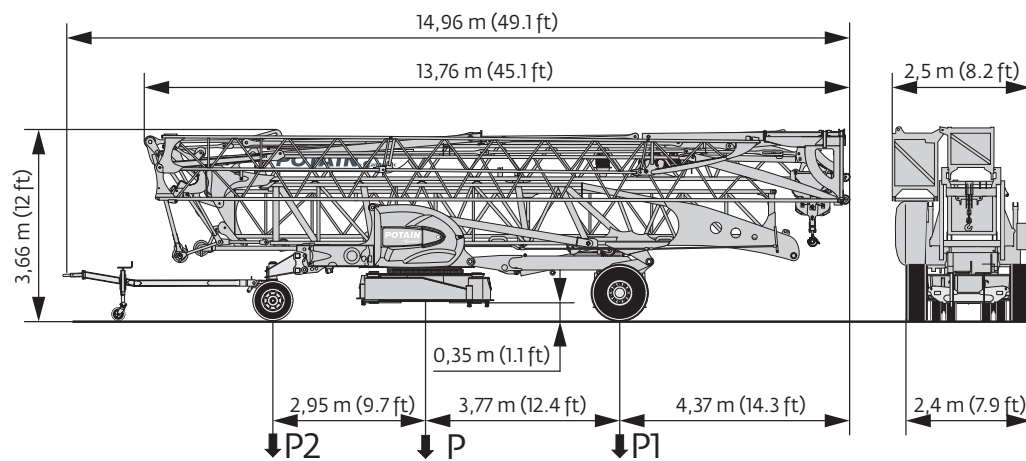

Weights

North American Highway 2-Axle

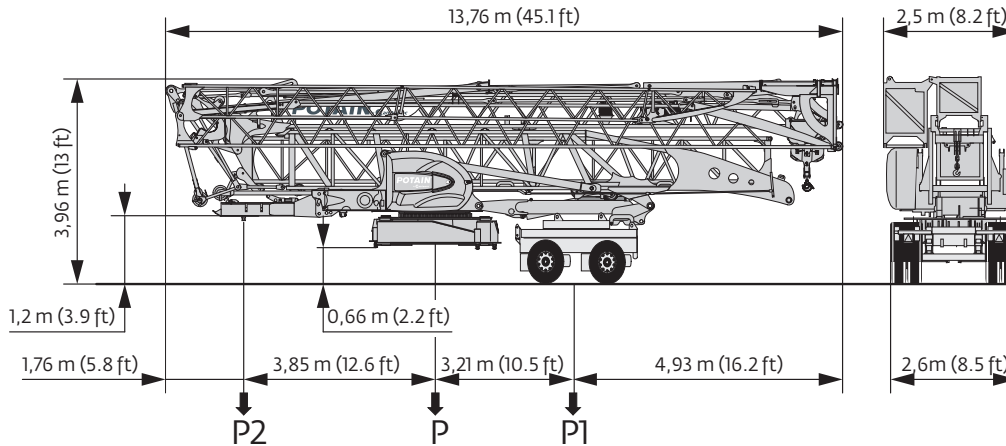

*Other axle sets are available.

Chassis data (in transport position)

	DJ100 / S120 10 km/h (6 mph)		DJ105 / S125 25 km/h (16 mph)		North American Highway 2-Axle	
	meters	(feet)	meters	(feet)	meters	(feet)
Overall length	14,96	49.1	14,96	49.08	13,76	45.1
Overall height	3,66	12.0	3,66	12.01	3,96	13.0
Overall width	2,5	8.2	2,5	8.2	2,5	8.2
Overhang	4,37	14.34	4,37	14.34	3,21	10.5

Weights

Crane weight less counterweight:	16 430 kg	36,222 lb
Counterweight for operation (15 slabs):	33 000 kg	72,753 lb
Crane with counterweight:	49 430 kg	108,975 lb

Crane with transport equipment

	DJ100 / S120 10 km/h (6 mph)		DJ105 / S125 25 km/h (16 mph)		North American Highway 2-Axle	
	kilograms	(pounds)	kilograms	(pounds)	kilograms	(pounds)
In transport with no counterweight:						
Gross (P)	16 970	37,412	17 260	38,052	17,890	39,441
Rear (P1)	9540	21,032	9750	21,495	12,350	27,227
Front (P2)	7430	16,380	7510	16,557	5540	12,214

NOTE: Dimensions and weights may vary due to manufacturing tolerances.

Dimensions

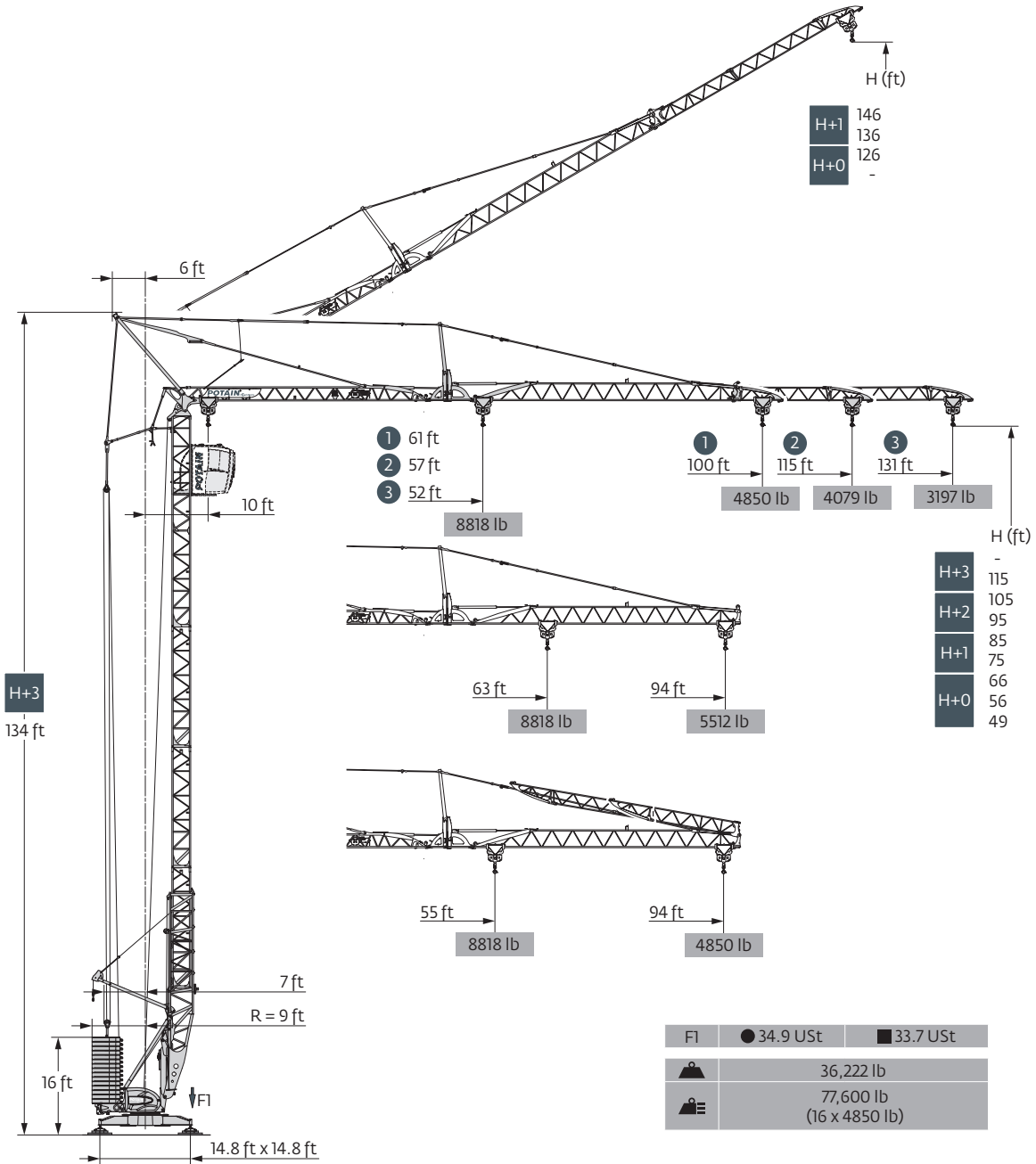

THIS CHART IS ONLY A GUIDE AND SHOULD NOT BE USED TO OPERATE THE CRANE.

Potain Igo T70 A The individual crane's load chart, operating instructions and other instructional plates must be read and understood prior to operating the crane.

Crane profile & working range

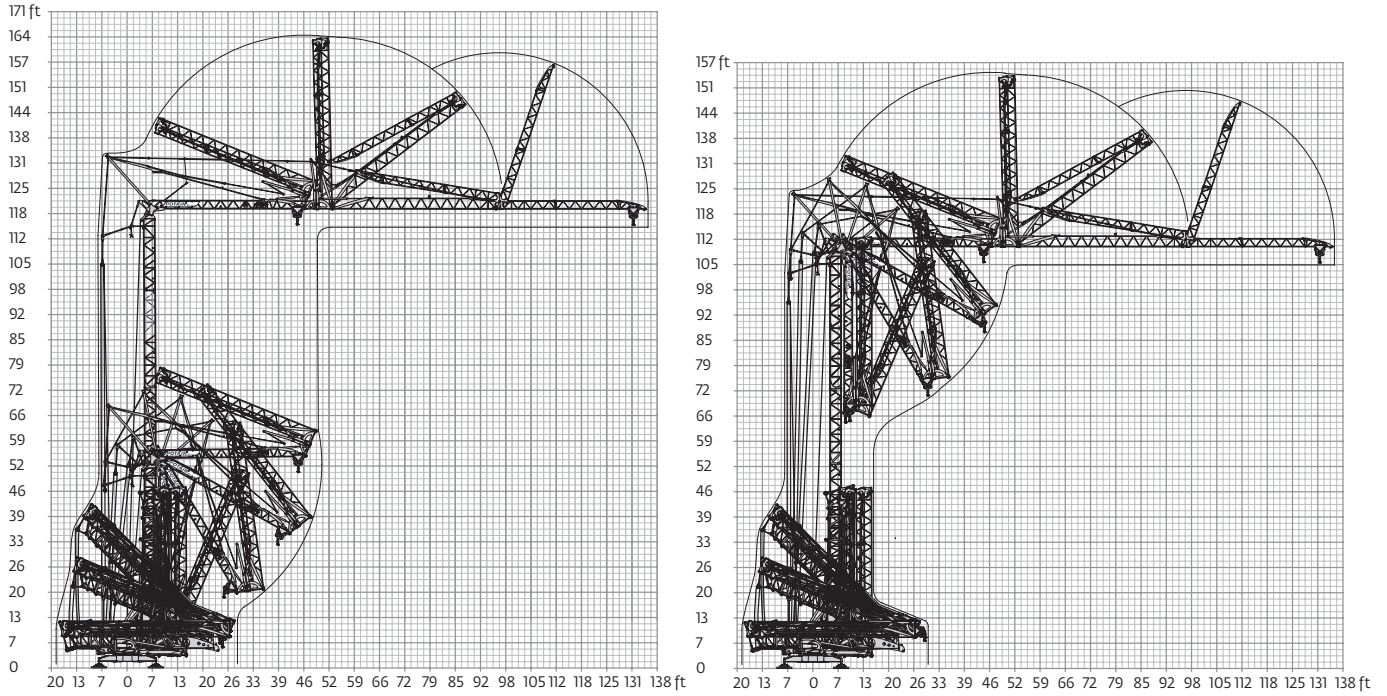

There are two possible profiles for the Igo T 70 A that are beneficial for erecting and dismantling on congested job sites.

Jib raised 30°

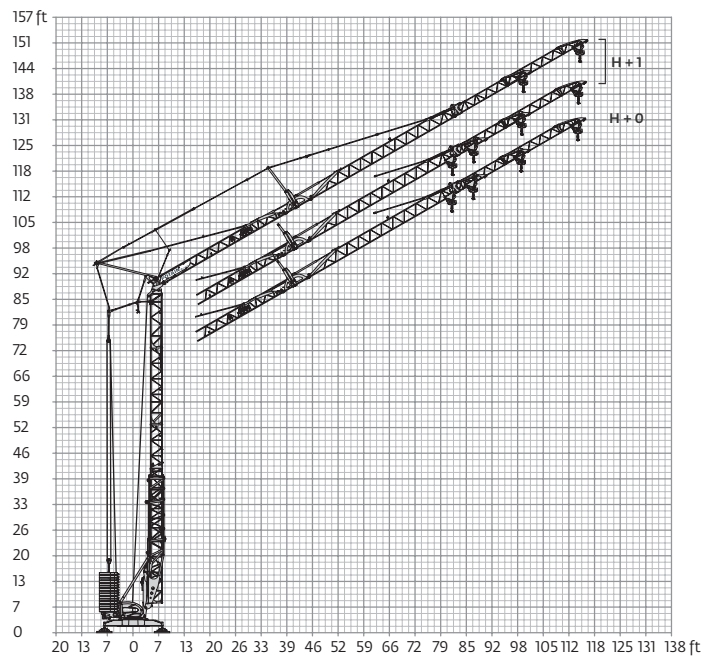

THIS CHART IS ONLY A GUIDE AND SHOULD NOT BE USED TO OPERATE THE CRANE.

The individual crane's load chart, operating instructions and other instructional plates must be read and understood prior to operating the crane.

Load charts

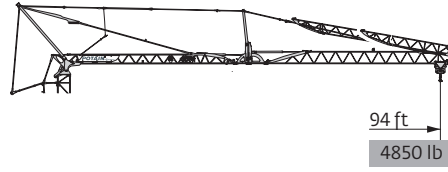
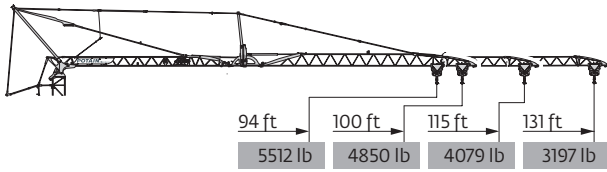

Height (ft)	10	52	59	66	72	79	85	86	92	98	105	112	118	125	131	ft
131 ft	▶	8818	7650	6746	5997	5401	4894	4850	4475	4101	3792	3527	3285	3064	2866	lb
								4850	4475	4101	3792	3527	3285	3064	2866	lb
								4850	4519	4189	3858	3638	3417	3197		lb
115 ft	▶	8818	8378	7385	6592	5930	5379	4916	4850	4531	4189	3880	3748			lb
								4850	4531	4189	3880	3748				lb
								4850	4519	4189	4079					lb
100 ft	▶	8818	8047	7165	6460	5886	5379	4938	4850							lb
								4850								lb
								4850								lb
94 ft	▶	8818	8400	7496	6768	6151	5622	5512								lb
								4850								lb
								4850								lb
131 ft	▶	8818	8069	7099	6327	5710	5181	4850	4729	4630						lb
115 ft	▶							4850	4729	4630						lb
								4850								lb

Height (ft)	131 ft	115 ft	100 ft	94 ft
H+2	105	95		
H+1	85	75		
H+0	66	56	49	

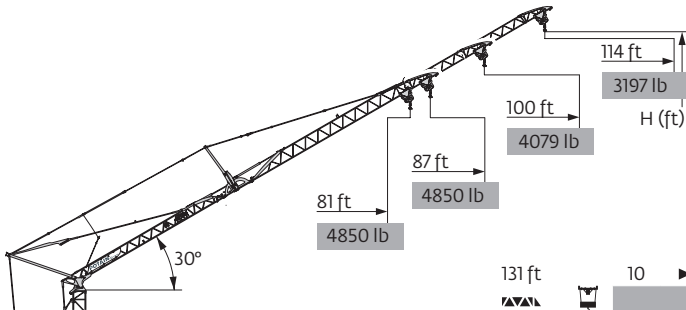

Height (ft)	131 ft	115 ft	100 ft	94 ft
H+1	146	138	-	-
H+0	126	118	111	107

Height (ft)	10	75	81	92	102	114	ft
131 ft	▶	4850	4409	3781	3329	2866	lb
							lb
							lb
115 ft	▶	4850	4453	4145	3748		lb
							lb
							lb
100 ft	▶		87				ft
			4850				lb
			4850				lb
94 ft	▶		81				ft
			4850				lb
			4850				lb

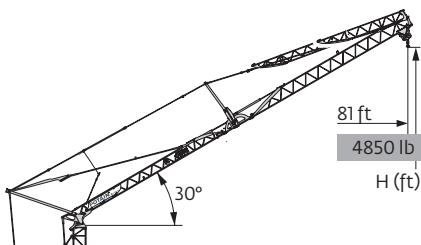

Height (ft)	10	81	ft
131 ft	▶	4850	lb
115 ft	▶	4850	lb
		4850	lb

Height (ft)	131 ft	115 ft
H+1	-	117
H+0	107	

THIS CHART IS ONLY A GUIDE AND SHOULD NOT BE USED TO OPERATE THE CRANE.

Potain Igo T70 A The individual crane's load chart, operating instructions and other instructional plates must be read and understood prior to operating the crane.

Mechanisms

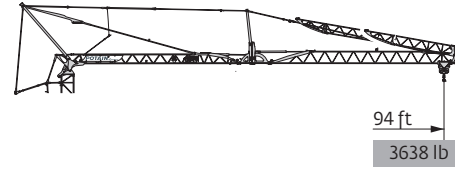
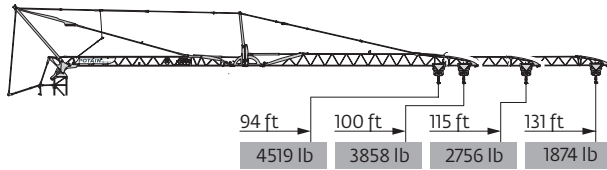

131 ft	10 ▶	63	66	72	79	85	92	98	105	112	118	125	131	ft
▲▲▲	▶	4850 4630 4079 3638 3307 2976 2756 2535 2315 2161 2006 1874												lb
115 ft	10 ▶			73	79	85	92	98	105	112	115			ft
▲▲▲	▶	4850 4409 3968 3638 3307 3086 2976 2756												lb
100 ft	10 ▶				83	85	92	100						ft
▲▲▲	▶	4850 4740 4299 3858												lb
94 ft	10 ▶				88	92	94							ft
▲▲▲	▶	4850 4630 4519												lb
131 ft														
115 ft	10 ▶			74	79	85	92	94						ft
▲▲▲	▶	4850 4519 4079 3748 3638												lb

▲▲▲	131 ft
	115 ft
	100 ft
	94 ft
H+3	-
	115

480 V - 60 Hz			U↑					UU↑					hp	kW
▲	15 LVF 11 Optima	fpm	11	59	98	118	223	6	30	49	59	112	15	11
		lb	4850	4850	4850	3307	1213	8818	8818	8818	6614	2425		
◀▶	3 DVF 5	fpm	49 - 98 - 135 (2866 → 8818 lb) 49 - 98 - 148 (0 → 2866 lb)									3	2.2	
⊙	RVF 151 Optima+	rpm	0 → 0.8									5.5	4	
◀●	i													

IEC 60204-32	kVA
480 V (+6% -10%) 60 Hz	→ 17 kVA → 19 kVA

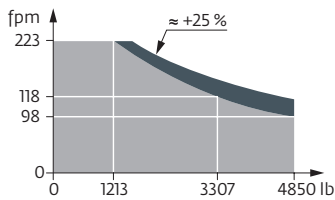

Metric dimensions

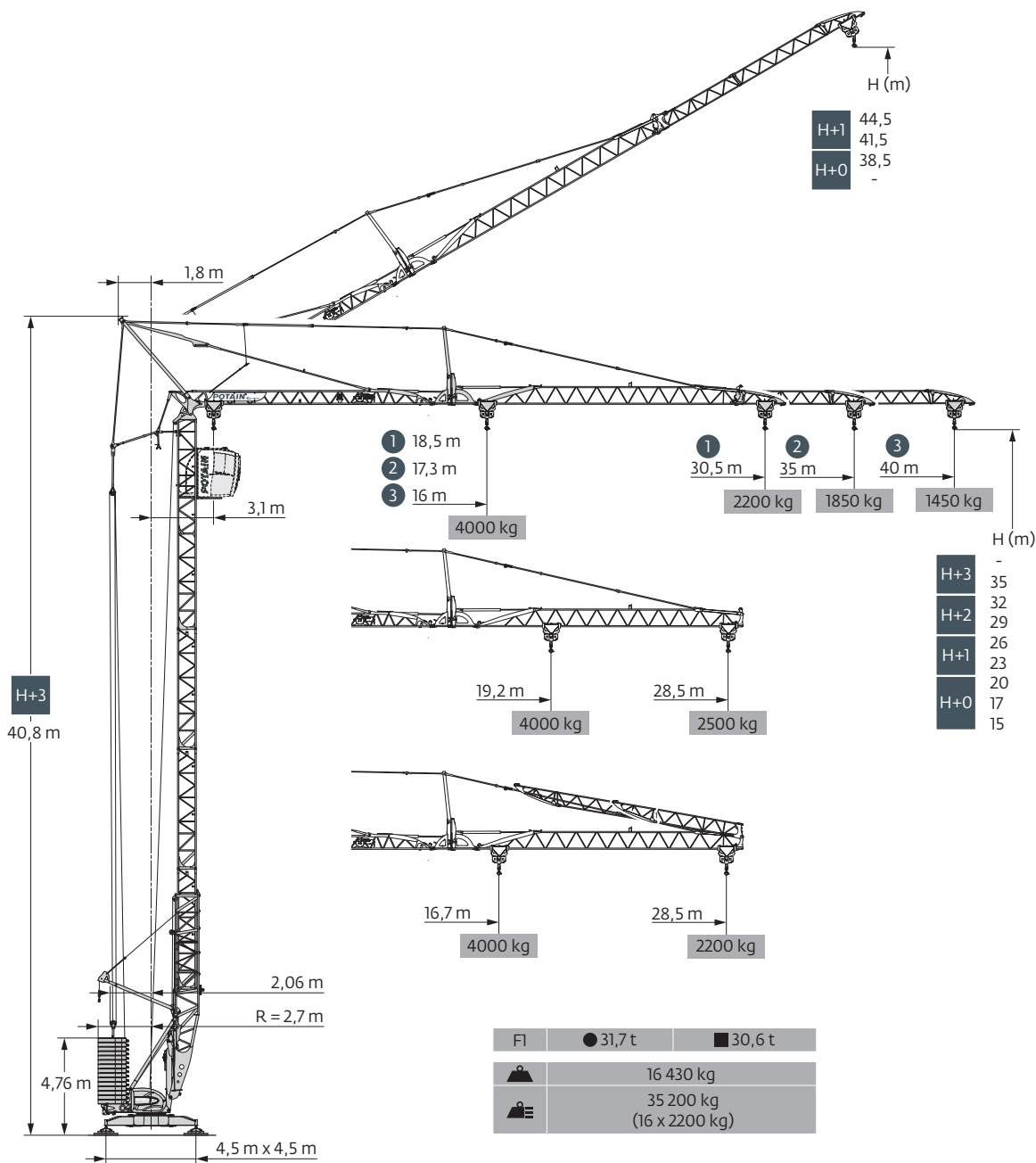

THIS CHART IS ONLY A GUIDE AND SHOULD NOT BE USED TO OPERATE THE CRANE.

Potain Igo T70 A The individual crane's load chart, operating instructions and other instructional plates must be read and understood prior to operating the crane.

Metric crane profile

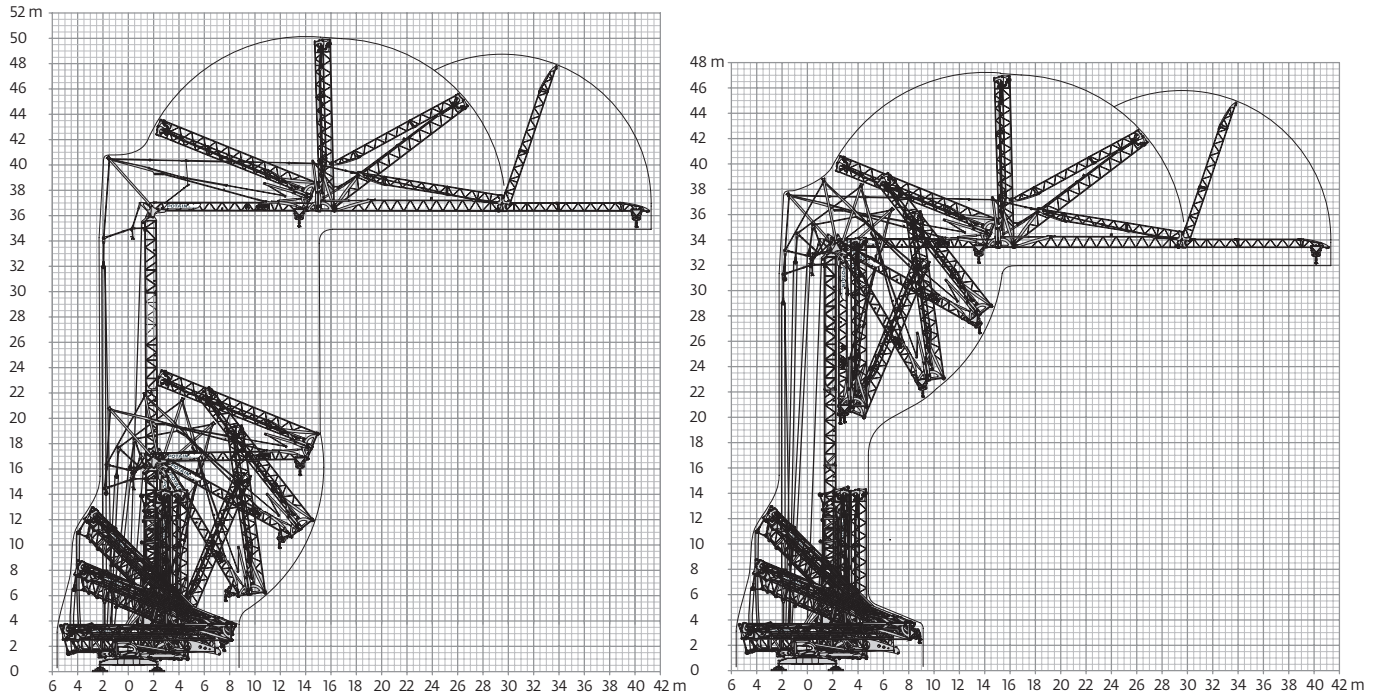

**There are two possible profiles for the Igo T 70 A that are beneficial for erecting and dismantling on congested job sites.*

Jib raised 30°

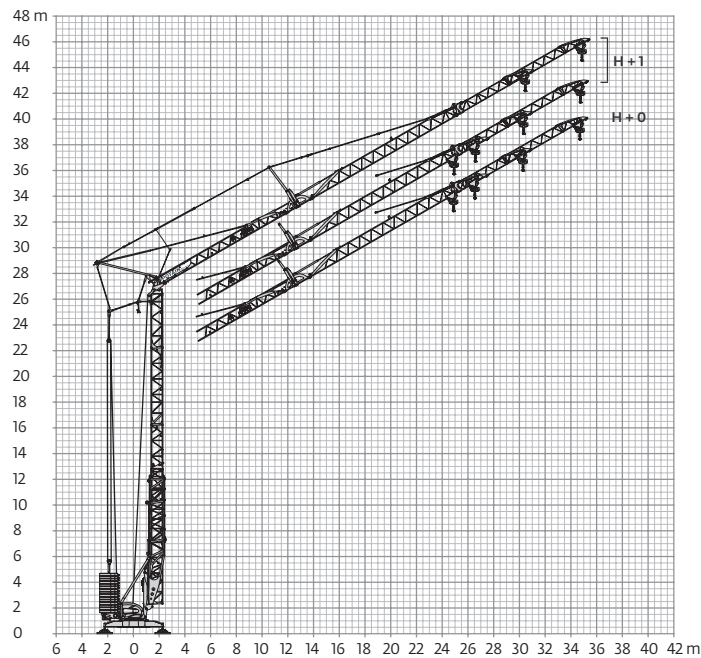

THIS CHART IS ONLY A GUIDE AND SHOULD NOT BE USED TO OPERATE THE CRANE.

The individual crane's load chart, operating instructions and other instructional plates must be read and understood prior to operating the crane.

Metric load charts

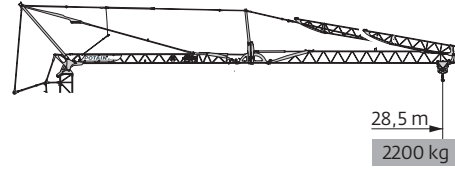
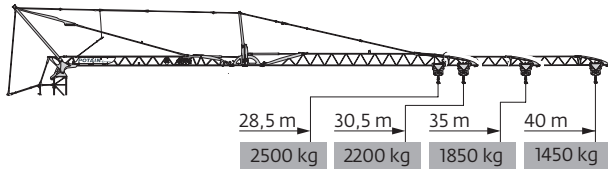

Crane Height (m)	3,1	16	18	20	22	24	26	26,2	28	30	32	34	36	38	40	Unit	
40 m	▶															kg	
				4000	3470	3060	2720	2450	2220	2030	1860	1720	1600	1490	1390	1300	kg
									2200	2030	1860	1720	1600	1490	1390	1300	kg
										2200	2050	1900	1750	1650	1450	kg	
35 m	▶															kg	
				4000	3800	3350	2990	2690	2440	2230	2055	1900	1760	1700		kg	
										2200	2055	1900	1760	1700		kg	
											2200	2050	1900	1850		kg	
30,5 m	▶															kg	
				4000	3650	3250	2930	2670	2440	2240	2200					kg	
										2200						kg	
											2200					kg	
28,5 m	▶															kg	
				4000	3810	3400	3070	2790	2550	2500						kg	
										2200						kg	
											2200					kg	

Crane Height (m)	40m
35 m	32
30,5 m	29
28,5 m	26
H+2	23
H+1	20
H+0	17
	15

Crane Height (m)	3,1	16,7	18	20	22	24	26	27,4	28	28,5	Unit
40 m	▶										kg
35 m		4000	3660	3220	2870	2590	2350	2200	2145	2100	kg
								2200	2145	2100	kg
										2200	kg

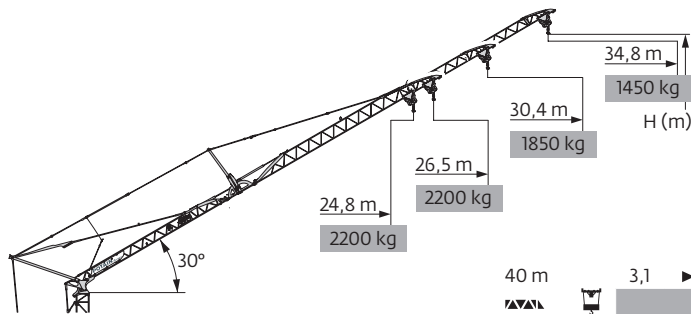

Crane Height (m)	40 m	35 m	30,5 m	28,5 m
H+1	44,5	42	-	-
H+0	41,5	39	36,7	35,7
	38,5	36	33,7	32,7

Crane Height (m)	3,1	▶	22,9	24,6	28	31	34,8	Unit
40 m								kg
								kg
								kg
35 m	▶							kg
								kg
								kg
30,5 m	▶							kg
								kg
								kg
28,5 m	▶							kg
								kg

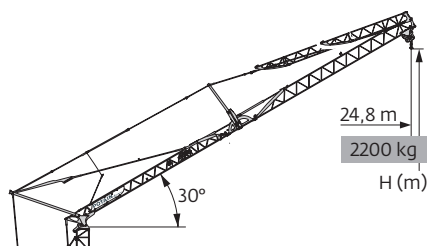

Crane Height (m)	3,1	▶	24,8	Unit
40 m				m
35 m				kg
				kg

Crane Height (m)	40 m
35 m	-
H+1	35,7
H+0	32,7

THIS CHART IS ONLY A GUIDE AND SHOULD NOT BE USED TO OPERATE THE CRANE.

Potain Igo T70 A The individual crane's load chart, operating instructions and other instructional plates must be read and understood prior to operating the crane.

Metric mechanisms

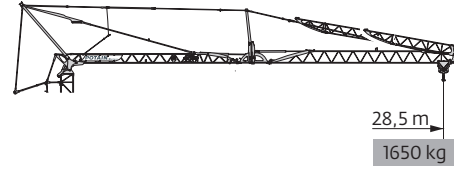
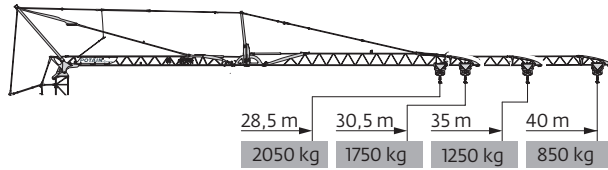

40 m	3,1	▶	19,2	20	22	24	26	28	30	32	34	36	38	40	m
			2200	2100	1850	1650	1500	1350	1250	1150	1050	980	910	850	kg
35 m	3,1	▶	22,3	24	26	28	30	32	34	35					
			2200	2000	1800	1650	1500	1400	1350	1250					
30,5 m	3,1	▶	25,2	26	28	30,5									
			2200	2150	1950	1750									
28,5 m	3,1	▶	26,8	28	28,5										
			2200	2100	2050										

	40m
	35 m
	30,5 m
	28,5 m
H+3	-
	35

40 m														
35 m	3,1	▶	22,6	24	26	28	28,5							
			2200	2050	1850	1700	1650							

480 V - 60 Hz													hp	kW	
	15 LVF 11 Optima	m/min	3,5	18	30	36	68	1,8	9	15	18	34	15	11	
		kg	2200	2200	2200	1500	550	4000	4000	4000	3000	1100			
	3 DVF 5	m/min	15 - 30 - 41 (1300 → 4000 kg) 15 - 30 - 45 (0 → 1300 kg)										3	2,2	
	RVF 151 Optima+	rpm	0 → 0,8										5,5	4	

	IEC 60204-32		
	480 V (+6% -10%) 60 Hz		→ 17 kVA
			→ 19 kVA

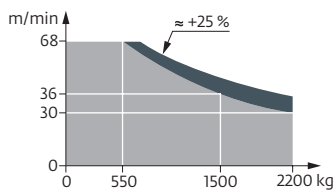

THIS CHART IS ONLY A GUIDE AND SHOULD NOT BE USED TO OPERATE THE CRANE.

The individual crane's load chart, operating instructions and other instructional plates must be read and understood prior to operating the crane.

Symbols glossary



Anemometer



Hoist



Outrigger



Traveling



Ballast



Hoisting mechanism



Reeving



Traversing trolley



Ballasting derrick



Hydraulic equipment



Reeving 2-part



Traversing trolley and load diagrams



Chassis



Jib



Reeving 4-part



Trolley



Controls



Jib extension



Swing



Wireless control



Electrical requirement



Mast



Transport axle

Notes

Regional headquarters

Manitowoc - Americas

Manitowoc, Wisconsin, USA

Tel: +1 920 684 6621

Fax: +1 920 683 6277

Shady Grove, Pennsylvania, USA

Tel: +1 717 597 8121

Fax: +1 717 597 4062

Manitowoc - Europe, Middle East & Africa

Ecully, France

Tel: +33 (0)4 72 18 20 20

Fax: +33 (0)4 72 18 20 00

Manitowoc - Asia Pacific

Shanghai, China

Tel: +86 21 6457 0066

Fax: +86 21 6457 4955

Regional offices

Americas

Brazil

Alphaville

Mexico

Monterrey

Chile

Santiago

Europe, Middle East & Africa

Algeria

Hydra

Czech Republic

Netvorice

France

Baudemont

Cergy

Decines

Germany

Langenfeld

Hungary

Budapest

Italy

Parabiago

Netherlands

Breda

Poland

Warsaw

Portugal

Baltar

Lisbon

Russia

Moscow

U.A.E.

Dubai

U.K.

Gawcott

Asia - Pacific

Australia

Brisbane

Melbourne

Sydney

China

Beijing

Xi'an

Korea

Seoul

India

Hyderabad

Pune

Philippines

Makati City

Singapore

Factories

Brazil

Alphaville

China

TaiAn

Zhangjiagang

France

Charlieu

La Clayette

Moulins

Germany

Wilhelmshaven

India

Pune

Italy

Niella Tanaro

Portugal

Baltar

Fânzeres

Slovakia

Saris

USA

Manitowoc

Port Washington

Shady Grove

This document is non-contractual. Constant improvement and engineering progress make it necessary that we reserve the right to make specification, equipment, and price changes without notice. Illustrations shown may include optional equipment and accessories and may not include all standard equipment.