



## 12000-1 Travel Spec

The control document for this is found in the operators manual. Please reference the control document to determine if updates have been made.

This file is reference only

REFERENCE ONLY!

### 8.4 SWING AND PROPEL STABILITY

1. Without carbody weight

Attachment	Counterweight ton (lbs)	All-round swing			Propelling on slope	
		Crawler extend	Crawler retract	When jacked up without crawler	Forward	Backward
Without attachment (Base machine only)	0 (Without)	○	○	○	○	○
	11.6 (25,573) (No.1)	○	△(No abrupt lever control)	×	○	○
	23.1 (50,925) (No.1 to No.2)	○	×	×	×	○
	34.6 (76,277) (No.1 to No.3)	×	×	×	×	×
With boom base (Boom angle : 30 degrees or less)	0 (Without)	○	○	○	○	○
	11.6 (25,573) (No.1)	○	○	×	○	○
	23.1 (50,925) (No.1 to No.2)	○	×	×	△(Slope:8 deg. or less)	○
	34.6 (76,277) (No.1 to No.3)	△(No abrupt lever control)	×	×	×	△

○ : Able to be operated  
 △ : Able to be operated with conditions  
 × : Unable to be operated

- (1) The table above shows the values for operation on a firm ground.  
 On a weak ground, operate with care after curing the ground.
- (2) As a principle, swinging on a trailer is prohibited.
- (3) Maximum slope angle is 21.8 degrees (40%).  
 This may become lower depending on condition (ground, crane configuration).
- (4) Travelling forward means the case where the counterweight is at the lower slope and the traveling backward where it is at the upper slope.

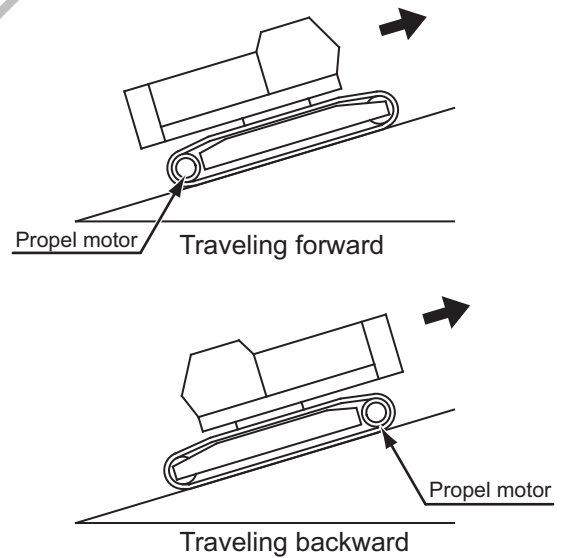

## 8. REFERENCE MATERIALS

### 2. With carbody weight

Attachment	Counterweight ton (lbs)	All-round swing			Propelling on slope	
		Crawler extend	Crawler retract	When jacked up without crawler	Forward	Backward
Without attachment (Base machine only)	0 (Without)	○	○	○	○	○
	11.6 (25,573) (No.1)	○	○	×	○	○
	23.1 (50,925) (No.1 to No.2)	○	×	×	△ (Slope:5 deg. or less)	○
	34.6 (76,277) (No.1 to No.3)	△ (No abrupt lever control)	×	×	×	△
With boom base (Boom angle : 30 degrees or less)	0 (Without)	○	○	○	○	○
	11.6 (25,573) (No.1)	○	○	△ (No abrupt lever control)	○	○
	23.1 (50,925) (No.1 to No.2)	○	×	×	△ (Slope:12 deg. or less)	○
	34.6 (76,277) (No.1 to No.3)	○	×	×	×	○

○ : Able to be operated  
 △ : Able to be operated with conditions  
 × : Unable to be operated

- (1) The table above shows the values for operation on a firm ground.  
On a weak ground, operate with care after curing the ground.
- (2) As a principle, swinging on a trailer is prohibited.
- (3) Maximum slope angle is 21.8 degrees (40%).  
This may become lower depending on condition (ground, crane configuration).
- (4) Travelling forward means the case where the counterweight is at the lower slope and the traveling backward where it is at the upper slope.

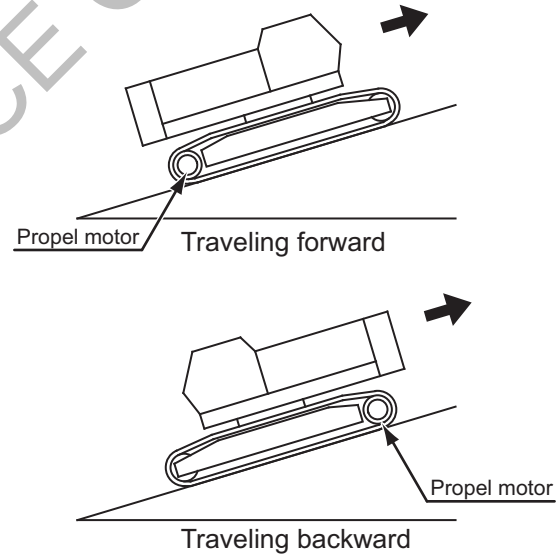

## 8.5 PROPEL ALLOWABLE SLOPE ANGLE

### 8.5.1 CRANE ATTACHMENT INSTALLED : BOOM INSERT CONFIGURATION

#### **CAUTION**

In the area showing [-] mark, do not propel.

Machine may overturn.

Failure to observe this precaution may result in serious injuries or loss of life.

If the machine has to propel by some reason, observe the following points.

- Do not propel with a load lifted.
- Propel with low speed and gently.
- Propel on the flat and firm ground.
- Ensure to check the ground condition and propel on the slope angle smaller than shown in the chart.
- Propel straight against slope.
- Provide the gentle slope at the beginning and end positions of slope.

Propel upward downward on slope

( $\theta$  : allowable angle)

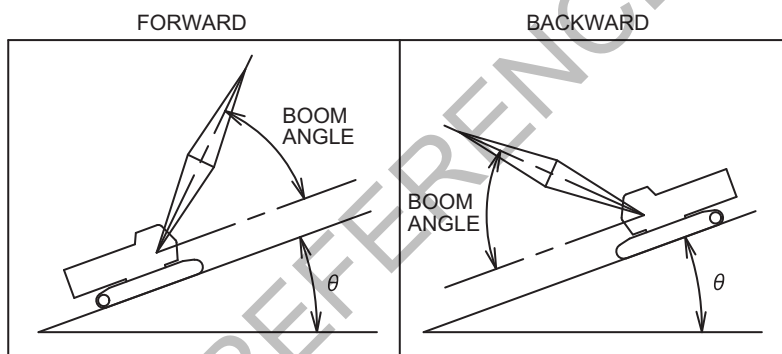

## 8. REFERENCE MATERIALS

### 1. CRANE PROPEL ALLOWABLE SLOPE ANGLE

#### (1) Without aux. sheave

(Unit : Degree)

Boom length m (ft)	Forward			Backward		
	Boom angle			Boom angle		
	35	40	50	40	50	60
15.2 (50)	7	7	5	8	8	8
18.3 (60)	8	8	6	8	8	8
21.3 (70)	8	8	7	8	8	8
24.4 (80)	8	8	7	8	8	8
27.4 (90)	8	8	7	8	8	8
30.5 (100)	8	8	8	8	8	8
33.5 (110)	8	8	8	8	8	8
36.6 (120)	8	8	8	8	8	8
39.6 (130)	8	8	8	8	8	8
42.7 (140)	8	8	8	8	8	8
45.7 (150)	8	8	8	8	8	8
48.8 (160)	8	8	8	7	8	8
51.8 (170)	8	8	8	5	6	8
54.9 (180)	8	8	8	3	5	6
57.9 (190)	8	8	8	1	3	5
61.0 (200)	8	8	8	-	2	4
64.0 (210)	8	8	8	-	-	2
67.1 (220)	8	8	8	-	-	1
70.1 (230)	8	8	8	-	-	-

#### (2) With aux. sheave

(Unit : Degree)

Boom length m (ft)	Forward			Backward		
	Boom angle			Boom angle		
	35	40	50	40	50	60
15.2 (50)	7	7	5	8	8	8
18.3 (60)	8	8	6	8	8	8
21.3 (70)	8	8	7	8	8	8
24.4 (80)	8	8	7	8	8	8
27.4 (90)	8	8	7	8	8	8
30.5 (100)	8	8	8	8	8	8
33.5 (110)	8	8	8	8	8	8
36.6 (120)	8	8	8	8	8	8
39.6 (130)	8	8	8	8	8	8
42.7 (140)	8	8	8	8	8	8
45.7 (150)	8	8	8	8	8	8
48.8 (160)	8	8	8	7	8	8
51.8 (170)	8	8	8	5	6	8
54.9 (180)	8	8	8	3	5	6
57.9 (190)	8	8	8	1	3	5
61.0 (200)	8	8	8	-	2	4
64.0 (210)	8	8	8	-	-	2
67.1 (220)	8	8	8	-	-	1

2. FIXED JIB PROPEL ALLOW SLOPE ANGLE

(Unit : Degree)

Jib length m (ft)	9.1 (30)					
Offset angle	10					
Configuration	Forward			Backward		
Boom length m (ft)	Boom angle			Boom angle		
	35	40	50	40	50	60
27.4 (90)	8	8	8	8	8	8
30.5 (100)	8	8	8	8	8	8
33.5 (110)	8	8	8	8	8	8
36.6 (120)	8	8	8	8	8	8
39.6 (130)	8	8	8	8	8	8
42.7 (140)	8	8	8	7	8	8
45.7 (150)	8	8	8	5	6	8
48.8 (160)	8	8	8	4	5	7
51.8 (170)	8	8	8	2	4	5
54.9 (180)	8	8	8	-	2	4
57.9 (190)	8	8	8	-	-	3
61.0 (200)	8	8	8	-	-	1

(Unit : Degree)

Jib length m (ft)	9.1 (30)					
Offset angle	30					
Configuration	Forward			Backward		
Boom length m (ft)	Boom angle			Boom angle		
	35	40	50	40	50	60
27.4 (90)	8	8	8	8	8	8
30.5 (100)	8	8	8	8	8	8
33.5 (110)	8	8	8	8	8	8
36.6 (120)	8	8	8	8	8	8
39.6 (130)	8	8	8	8	8	8
42.7 (140)	8	8	8	7	8	8
45.7 (150)	8	8	8	5	6	8
48.8 (160)	8	8	8	4	5	7
51.8 (170)	8	8	8	2	4	5
54.9 (180)	8	8	8	-	2	4
57.9 (190)	8	8	8	-	-	3
61.0 (200)	8	8	8	-	-	1

## 8. REFERENCE MATERIALS

(Unit : Degree)

Jib length m (ft)	12.2 (40)					
Offset angle	10					
Configuration	Forward			Backward		
Boom length m (ft)	Boom angle			Boom angle		
	35	40	50	40	50	60
27.4 (90)	8	8	8	8	8	8
30.5 (100)	8	8	8	8	8	8
33.5 (110)	8	8	8	8	8	8
36.6 (120)	8	8	8	8	8	8
39.6 (130)	8	8	8	8	8	8
42.7 (140)	8	8	8	7	7	8
45.7 (150)	8	8	8	4	6	7
48.8 (160)	8	8	8	3	5	6
51.8 (170)	8	8	8	1	3	5
54.9 (180)	8	8	8	-	1	4
57.9 (190)	8	8	8	-	-	2
61.0 (200)	8	8	8	-	-	1

(Unit : Degree)

Jib length m (ft)	12.2 (40)					
Offset angle	30					
Configuration	Forward			Backward		
Boom length m (ft)	Boom angle			Boom angle		
	35	40	50	40	50	60
27.4 (90)	8	8	8	8	8	8
30.5 (100)	8	8	8	8	8	8
33.5 (110)	8	8	8	8	8	8
36.6 (120)	8	8	8	8	8	8
39.6 (130)	8	8	8	8	8	8
42.7 (140)	8	8	8	7	7	8
45.7 (150)	8	8	8	4	6	7
48.8 (160)	8	8	8	3	5	6
51.8 (170)	8	8	8	1	3	5
54.9 (180)	8	8	8	-	1	3
57.9 (190)	8	8	8	-	-	2
61.0 (200)	8	8	8	-	-	1

(Unit : Degree)

Jib length m (ft)	15.2 (50)					
Offset angle	10					
Configuration	Forward			Backward		
Boom length m (ft)	Boom angle			Boom angle		
	35	40	50	40	50	60
27.4 (90)	8	8	8	8	8	8
30.5 (100)	8	8	8	8	8	8
33.5 (110)	8	8	8	8	8	8
36.6 (120)	8	8	8	8	8	8
39.6 (130)	8	8	8	8	8	8
42.7 (140)	8	8	8	6	7	8
45.7 (150)	8	8	8	4	5	7
48.8 (160)	8	8	8	3	4	6
51.8 (170)	8	8	8	1	3	5
54.9 (180)	8	8	8	-	1	3
57.9 (190)	8	8	8	-	-	2
61.0 (200)	8	8	8	-	-	1

(Unit : Degree)

Jib length m (ft)	15.2 (50)					
Offset angle	30					
Configuration	Forward			Backward		
Boom length m (ft)	Boom angle			Boom angle		
	35	40	50	40	50	60
27.4 (90)	8	8	8	8	8	8
30.5 (100)	8	8	8	8	8	8
33.5 (110)	8	8	8	8	8	8
36.6 (120)	8	8	8	8	8	8
39.6 (130)	8	8	8	8	8	8
42.7 (140)	8	8	8	6	7	8
45.7 (150)	8	8	8	4	5	7
48.8 (160)	8	8	8	3	4	6
51.8 (170)	8	8	8	1	2	4
54.9 (180)	8	8	8	-	1	3
57.9 (190)	8	8	8	-	-	2
61.0 (200)	8	8	8	-	-	1



## 8. REFERENCE MATERIALS

(Unit : Degree)

Jib length m (ft)	18.3 (60)					
Offset angle	10					
Configuration	Forward			Backward		
Boom length m (ft)	Boom angle			Boom angle		
	35	40	50	40	50	60
27.4 (90)	8	8	8	8	8	8
30.5 (100)	8	8	8	8	8	8
33.5 (110)	8	8	8	8	8	8
36.6 (120)	8	8	8	8	8	8
39.6 (130)	8	8	8	7	8	8
42.7 (140)	8	8	8	5	6	8
45.7 (150)	8	8	8	3	4	6
48.8 (160)	8	8	8	2	4	6
51.8 (170)	8	8	8	-	2	4
54.9 (180)	8	8	8	-	-	3
57.9 (190)	8	8	8	-	-	1
61.0 (200)	8	8	8	-	-	-

(Unit : Degree)

Jib length m (ft)	18.3 (60)					
Offset angle	30					
Configuration	Forward			Backward		
Boom length m (ft)	Boom angle			Boom angle		
	35	40	50	40	50	60
27.4 (90)	8	8	8	8	8	8
30.5 (100)	8	8	8	8	8	8
33.5 (110)	8	8	8	8	8	8
36.6 (120)	8	8	8	8	8	8
39.6 (130)	8	8	8	7	8	8
42.7 (140)	8	8	8	5	6	8
45.7 (150)	8	8	8	3	4	6
48.8 (160)	8	8	8	2	4	5
51.8 (170)	8	8	8	-	2	4
54.9 (180)	8	8	8	-	-	3
57.9 (190)	8	8	8	-	-	1
61.0 (200)	8	8	8	-	-	-