

Manitowoc

SERVICE/MAINTENANCE MANUAL

This manual has been prepared for and is considered part of -

10000-1/11000-1/10000E-1

Model Number

1000/1100Ref

Serial Number

This Manual is Divided into the following Sections:

	SAFETY SECTION
SECTION 1	REFERENCE MATERIALS
SECTION 2	TEST PROCEDURES
SECTION 3	GENERAL
SECTION 4	POWER TRAIN
SECTION 5	HYDRAULIC SYSTEM
SECTION 6	HOIST SYSTEM
SECTION 7	BOOM HOIST SYSTEM
SECTION 8	SWING SYSTEM
SECTION 9	PROPEL SYSTEM
SECTION 10	ELECTRICAL SYSTEM
SECTION 11	AIR CONDITIONER
SECTION 12	TROUBLESHOOTING

NOTICE

The serial number of the crane is the only method Manitowoc has of providing you with correct parts and service information.

Always furnish serial number of crane and its attachments when ordering parts or discussing service problems with your Manitowoc distributor or the factory.



WARNING

To prevent death or serious injury:

- Avoid unsafe operation and maintenance.
Crane and attachments must be operated and maintained by trained and experienced personnel. Manitowoc is not responsible for qualifying these personnel.
- Do not operate or work on crane or attachments without first reading and understanding instructions contained in Operator Information Manual and Service Manual supplied with crane and applicable attachments.
- Store Operator Information Manual and Service Manual in operator's cab.
If Operator Information Manual or Service Manual is missing from cab, contact your Manitowoc distributor for a new one.



Reference Only

This Page Blank

SAFETY

1. REFERENCE MATERIALS

1.1	10000-1/11000-1 SPECIFICATION.....	1-3
1.1.1	CRANE OUTER DIMENSION	1-3
1.1.2	CRANE SPECIFICATION, PERFORMANCE.....	1-4
1.1.3	CRANE WORKING RANGES	1-5
1.2	10000-1/11000-1 DIMENSION, WEIGHT OF EACH COMPONENT	1-8
1.2.1	MAIN MACHINERY	1-8
1.2.2	COUNTERWEIGHT.....	1-9
1.2.3	ATTACHMENT	1-11
1.3	10000-1/11000-1 SWING AND PROPEL STABILITY	1-14
1.4	10000-1/11000-1 PROPEL ALLOWABLE SLOPE ANGLE.....	1-16
1.4.1	CRANE ATTACHMENT INSTALLED : BOOM INSERT CONFIGURATION.....	1-16
1.5	10000E-1 SPECIFICATION	1-22
1.5.1	CRANE OUTER DIMENSION	1-22
1.5.2	CRANE SPECIFICATION, PERFORMANCE.....	1-24
1.5.3	CRANE WORKING RANGES	1-25
1.6	10000E-1 DIMENSION, WEIGHT OF EACH COMPONENT	1-28
1.6.1	MAIN MACHINERY	1-28
1.6.2	COUNTERWEIGHT.....	1-29
1.6.3	COUNTERWEIGHT WITH SELF-REMOVABLE DEVICE (OPTION)	1-30
1.6.4	ATTACHMENT	1-31
1.7	10000E-1 SWING AND PROPEL STABILITY.....	1-35
1.8	10000E-1 PROPEL ALLOWABLE SLOPE ANGLE	1-37
1.8.1	CRANE ATTACHMENT INSTALLED : BOOM INSERT CONFIGURATION.....	1-37
1.9	ENGINE MAIN SPECIFICATION	1-43

2. MAINTENANCE STANDARDS TEST PROCEDURES

2.1	MAINTENANCE STANDARD.....	2-3
2.1.1	PIN, BUSHING, SPRING, LINING AND SHEAVE	2-3
2.1.2	PROPEL DEVICE.....	2-10
2.2	PERFORMANCE STANDARD AND TEST PROCEDURE	2-18
2.2.1	OPERATING SPEED	2-19
2.2.2	POINT AND METHOD OF MEASURING PRESSURE	2-20
2.2.3	SLEWING RING	2-25

3. GENERAL WORK STANDARD

3.1	TIGHTENING TORQUE OF CAP SCREWS AND NUTS	3-3
-----	--	-----

TABLE OF CONTENTS

3.1.1	STANDARD TIGHTENING TORQUE	3-3
3.1.2	TIGHTENING TORQUE OF HYDRAULIC FITTINGS.....	3-6
3.2	STANDARD PARTS.....	3-8
3.2.1	BOLT	3-8
3.2.2	O-RING.....	3-9
3.2.3	BACK-UP RING.....	3-10
3.2.4	BITE TYPE FITTING	3-11
3.3	CONVERSION TABLE.....	3-13
3.3.1	UNIT CONVERSION	3-13
3.3.2	MILLIMETER : INCH CONVERSION TABLE.....	3-14
3.3.3	METER AND FOOT CONVERSION TABLE.....	3-16
3.3.4	GRADE CONVERSION TABLE	3-17
3.3.5	UNIT WEIGHT TABLE	3-17
3.3.6	SYSTEM INTERNATIONAL (SI) UNIT CONVERSION TABLE	3-18
 4. POWER TRAIN		
4.1	INTRODUCTION.....	4-3
4.2	ENGINE.....	4-6
4.2.1	INTRODUCTION	4-6
4.2.2	REMOVAL.....	4-6
4.2.3	REPAIR AND MAINTENANCE	4-10
4.2.4	INSTALLATION	4-10
4.3	PUMP DRIVE ASSEMBLY.....	4-13
4.3.1	INTRODUCTION.....	4-13
4.3.2	REMOVAL.....	4-14
4.3.3	DISASSEMBLING THE POWER DIVIDER.....	4-17
4.3.4	CHECK AND REPAIR OF THE POWER DIVIDER.....	4-19
4.3.5	ASSEMBLING THE POWER DIVIDER.....	4-20
4.3.6	RE-INSTALLATION.....	4-21
 5. HYDRAULIC SYSTEM		
5.1	LOCATION OF MAIN HYDRAULIC COMPONENTS	5-3
5.2	HYDRAULIC CIRCUITS AND COMPONENTS	5-9
5.2.1	COMPONENT SPECIFICATIONS	5-9
5.2.2	LAYOUT OF HYDRAULIC COMPONENTS.....	5-13
5.3	HYDRAULIC SYSTEM.....	5-27
5.3.1	PREFACE.....	5-27
5.3.2	OUTLINE	5-27
5.3.3	OIL FLOW FROM No.1 AND No.2 PUMPS	5-28

TABLE OF CONTENTS

5.3.4	OIL FLOW FROM No.3 PUMP	5-30
5.3.5	OIL FLOW FROM No.4 AND No.5 PUMPS (FRONT, REAR DRUM BRAKE COOLING)	5-32
5.3.6	OIL FLOW FROM No.6 PUMP	5-34
5.3.7	OIL FLOW FROM No.7 PUMP	5-38
5.4	VALVE	5-46

6. HOIST SYSTEM

6.1	APPARATUS AND LOCATION OF COMPONENTS	6-3
6.2	ADJUSTMENT OF DRUM LOCK.....	6-5
6.3	WINCH	6-6
6.3.1	WINCH INSTALLATION	6-6
6.3.2	WINCH ASSEMBLY	6-8
6.3.3	REDUCTION UNIT ASSEMBLY	6-10
6.4	BRAKE PEDAL.....	6-12
6.4.1	ASSEMBLY DRAWING	6-12
6.4.2	ADJUSTING THE BRAKE PEDAL	6-14
6.5	BLEEDING AIR FROM BRAKE CIRCUIT	6-15
6.6	CONSTRUCTION AND FUNCTION	6-17
6.6.1	HYDRAULIC SCHEMATIC.....	6-17
6.6.2	LIFTING A LOAD	6-20
6.6.3	HOLDING A RAISED LOAD	6-24
6.6.4	LOWERING A LOAD (POWER LOWERING)	6-28
6.6.5	FREE FALL OPERATION	6-32

7. BOOM HOIST SYSTEM

7.1	APPARATUS AND LOCATION OF COMPONENTS	7-3
7.2	BOOM HOIST WINCH INSTALLATION.....	7-5
7.3	BOOM DRUM LOCK.....	7-6
7.3.1	ASSEMBLY DRAWING	7-6
7.3.2	ADJUSTING THE BOOM DRUM LOCK.....	7-7
7.4	REDUCTION UNIT	7-8
7.5	CONSTRUCTION AND FUNCTION	7-11
7.5.1	HYDRAULIC SCHEMATIC.....	7-11
7.5.2	RAISING THE BOOM.....	7-12
7.5.3	NEUTRAL (HOLDING BOOM)	7-14
7.5.4	LOWERING BOOM	7-16

TABLE OF CONTENTS

8. SWING SYSTEM

8.1 APPARATUS AND LOCATION OF COMPONENTS	8-3
8.2 CONSTRUCTION AND FUNCTION	8-4
8.2.1 HYDRAULIC SCHEMATIC.....	8-4
8.2.2 SWING	8-6
8.2.3 STOPPING	8-8
8.3 SWING REDUCTION UNIT	8-11
8.4 SWING BEARING	8-14
8.5 SWING LOCK	8-16

9. PROPEL SYSTEM

9.1 APPARATUS AND LOCATION OF COMPONENTS	9-3
9.2 PROPEL REDUCTION UNIT	9-4
9.2.1 MOTOR AND REDUCTION UNIT	9-6
9.3 ADJUSTMENT	9-10
9.4 CONSTRUCTION AND FUNCTION	9-11
9.4.1 HYDRAULIC SCHEMATIC.....	9-11
9.4.2 PROPELLING (RIGHT SIDE FORWARD)	9-12
9.4.3 STOPPING	9-14

10. ELECTRIC SYSTEM

10.1 ELECTRICAL	10-3
10.1.1 ELECTRICAL WIRING SCHEMATIC.....	10-3
10.1.2 CONNECTOR LAYOUT	10-21
10.1.3 LOCATION AND USE OF FUSE.....	10-155
10.1.4 WIPER CONTROL RELAY (2479R1366)	10-161
10.1.5 PRESSURE SWITCH (FOR PROPEL MOTION DETECT)	10-162
10.1.6 PRESSURE SWITCH (FOOT BRAKE).....	10-163
10.1.7 PRESSURE SENSOR.....	10-164
10.1.8 INCLINATION SENSOR.....	10-168
10.1.9 BUZZER UNIT	10-169
10.1.10 RELAY BOX (GG24E00038F1).....	10-171
10.1.11 RELAY BOX (GG24E00036F1).....	10-182
10.1.12 LOAD CELL (CRANE).....	10-186
10.1.13 ANGLE SENSOR	10-187
10.1.14 TROUBLESHOOTING OF EXHAUST GAS THIRD REGULATION ENGINE	10-188
10.1.15 HOW TO CHECK THE FAILURE CONTENTS	10-189
10.1.16 CHECKING OF DIAGNOSIS LAMP FUNCTION	10-195
10.1.17 ENGINE ECU	10-196

TABLE OF CONTENTS

10.2 LOAD SAFETY DEVICE	10-198
10.2.1 CONFIGURATION OF SCREENS	10-199
10.2.2 SYSTEM DAIGRAM	10-200
10.2.3 MONITOR INDICATION	10-201
10.2.4 DETAIL OF MOMENT LIMITER CONNECTOR.....	10-207
10.2.5 SHIFTING TO MAINTENANCE SCREEN.....	10-220
10.2.6 INPUT, OUTPUT SIGNAL	10-222
10.2.7 ML FUNCTION SETTING.....	10-231
10.2.8 DATA COPY, FORMAT	10-235
10.2.9 LANGUAGE, UNIT SETTING.....	10-241
10.2.10ML ADJUSTMENT (NORMAL).....	10-242
10.2.11ML ADJUSTMENT (TEMPORARY)	10-270
10.2.12OPERATION PROGRESS	10-271
10.2.13VERSION INFORMATION	10-273
10.2.14FAILURE HISTORY.....	10-274
10.2.15ADJUSTMENT DATA	10-278
10.2.16DOWNLOAD ML PROGRAM.....	10-286
10.2.17DOWNLOAD OF MONITOR PROGRAM.....	10-288
10.3 MAIN CONTROLLER	10-294
10.3.1 ARRANGEMENT OF MAIN CONTROLLER	10-294
10.3.2 COMPOSITION OF SYSTEM	10-295
10.3.3 FUNCTION OF MAIN CONTROLLER.....	10-296
10.3.4 MAIN CONTROLLER 1, 2 (HARDWARE).....	10-336
10.3.5 SPECIFICATIONS OF MAIN CONTROLLER OUTPUT	10-337
10.3.6 ARRANGEMENT OF MAIN CONTROLLER CONNECTOR PIN	10-345
10.3.7 ADJUSTMENT OF MAIN CONTROLLER.....	10-361
10.3.8 CONTROLLER MALFUNCTION EMERGENCY MEASURES.....	10-365

11. AIR CONDITIONER

11.1 AIR CONDITIONER	11-3
11.2 PARTS ILLUSTRATION.....	11-11
11.3 DISASSEMBLY AND ASSEMBLY OF THE UNIT.....	11-14
11.3.1 REMOVAL OF THE BLOWER UNIT	11-14
11.3.2 REPLACING THE BLOWER MOTOR.....	11-15
11.3.3 REPLACING THE BLOWER CONTROLLER.....	11-15
11.3.4 REMOVAL OF THE HEATER CORE	11-15
11.3.5 REMOVAL OF THE AIR-CON UNIT CASE-FRONT AND- REAR	11-16
11.3.6 REPLACING THE EVAPORATOR AND EXPANSION VALVE.....	11-17
11.3.7 INSTALLATION OF EVAPORATOR SENSOR	11-17

TABLE OF CONTENTS

11.3.8 REPLACING THE MOTOR ACTUATOR	11-18
11.4 FAULT DETECTION FROM THE CONTROL PANEL INDICATION	11-19
11.4.1 GENERAL	11-19
11.4.2 FAULT IN THE INPUT AND OUTPUT CIRCUIT OF THE MOTOR ACTUATOR	11-19
11.4.3 FAULT IN THE THERMISTOR SENSOR CIRCUIT	11-19
11.5 BASIC SYSTEM OF HVAC.....	11-20
11.6 RECHARGING OF THE COOLANT	11-25
11.6.1 CAUTION AT WORK.....	11-25
11.6.2 WORK PROCEDURE	11-27
11.6.3 RECHARGING PROCEDURE	11-29
11.7 ELECTRIC WIRING DIAGRAM	11-35
12. TROUBLESHOOTING	
12.1 TROUBLESHOOTING	12-3

SAFETY

Reference Only

Reference Only

SAFETY INFORMATION

Most accidents, which occur during operation, are due to neglect of precautionary measures and safety rules. Sufficient care should be taken to avoid these accidents.

Erroneous operation, lubrication or maintenance services are very dangerous and may cause injury or death of personnel.

Thus, precautionary measures, or notes, written in this manual should be read and understood by personnel before starting each task.

Operation, inspection, and maintenance should be carefully carried out, and safety must be given the first priority. Messages of safety are indicated with caution marks. The safety information contained in this manual is intended only general safety information.

Messages of safety appear in this manual and on the machine. All messages of safety are identified by the words "DANGER", "WARNING" and "CAUTION". These words mean the following:



Indicates an imminently hazardous situation which, if not avoided, will result in loss of life or serious injuries.



Indicates a potentially hazardous situation which, if not avoided, could result in loss of life or serious injuries.



Indicates a potentially hazardous situation which, if not avoided, may result in minor or moderate injuries. It may also be used to alert against possible damage to the machine and its components.

Note

Supplementary explanation.

It is very difficult for us to forecast every danger that may occur during operation. However, safety can be ensured by operating this machine according to methods recommended by Manitowoc. While operating machine, be sure to perform work with great care, so as to not damage the machine, or let accidents occur.

Please continue studying this manual until proper operation is completely understood.

EXPLANATION OF WARNING LABELS IN THE MACHINE

Since the warning labels are installed in the machine and indicated with the three stages in the same way as the warning description, confirm the positions and contents of all warning labels first.

Put them to the practical use to secure safety when operating, checking and performing maintenance.

HANDLING OF WARNING LABELS IN THE MACHINE

1. When the warning label is damaged or stained, order it to the designated service shop.
2. Do not remove the warning labels.
3. When the surface of the warning label is soiled and difficult to be seen, wipe it cleanly.

Reference Only

LABEL LAYOUT

* Numbers in the drawings correspond with those in the label explanation detail after P.0-14.

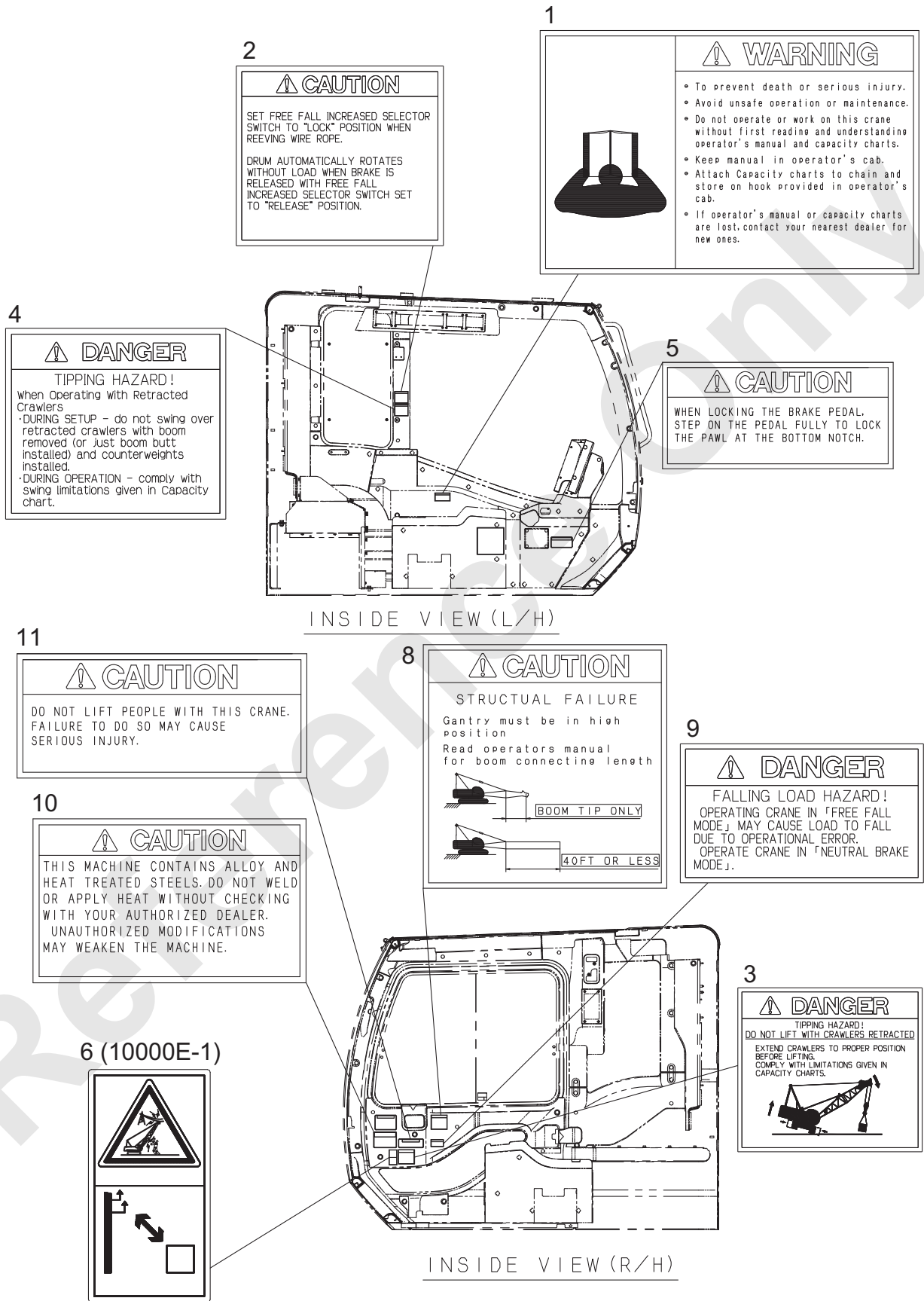

32 (10000E-1)

 CAUTION
<p>Not allowed to use main and aux. drums at the same time.</p>

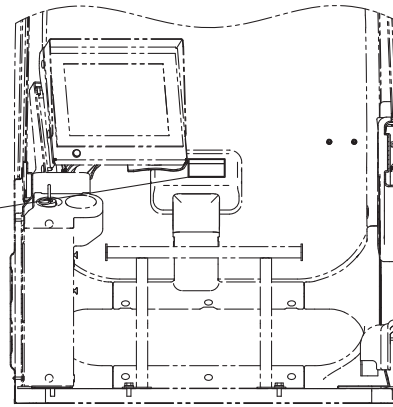

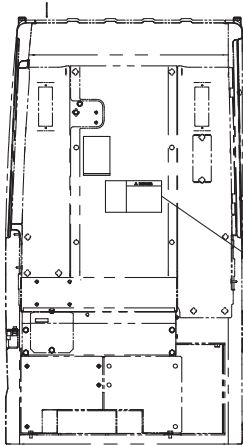

INSIDE VIEW
(FRONT)



CAB INSIDE VIEW
(REAR)

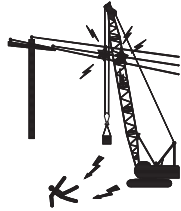

6

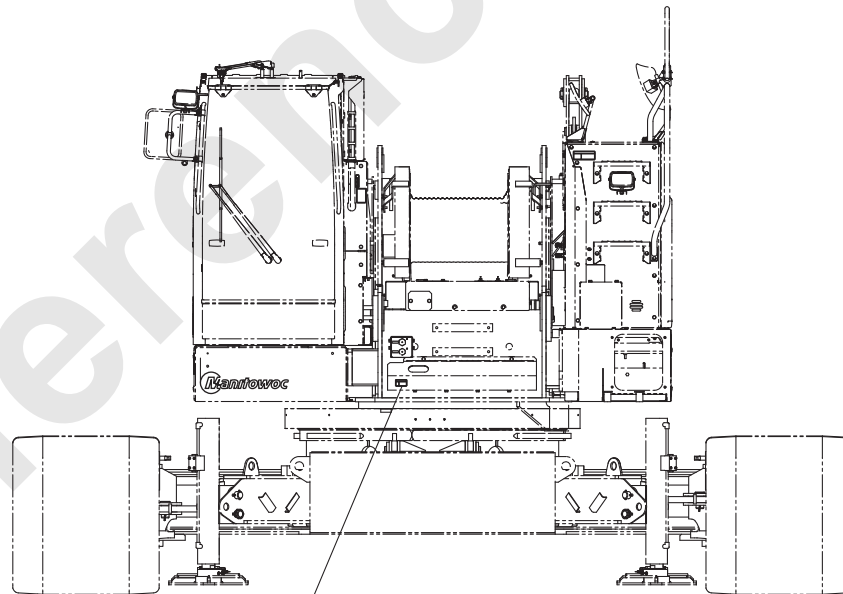
	 DANGER
	<p>ELECTROCUTION HAZARD THIS CRANE IS NOT INSULATED</p> <ul style="list-style-type: none"> ▣ To avoid death or serious injury, keep all parts of this crane, rigging and materials being lifted at least 20 ft (6m) away from all electrical power lines and equipment. ▣ Keep away from this crane if it is being operated near electrical power lines or equipment. ▣ Before operating this crane in vicinity of power lines or equipment, notify power utility company. Have power turned off. ▣ Follow instructions in Operator's Manual.



FRONT VIEW

31

 DANGER	<p>Stay clear of this area Place boom, block, on ground before performing maintenance</p>
 <p>FALLING LOAD HAZARD!</p>	

24

 <p>FALLING LOAD HAZARD!</p>	<p>DANGER</p> <p>Engage gantry pins when gantry is in high position. Connect backhitch [tension bars] to rotating bed or counterweight when gantry is in low position.</p>
--	---

23

 <p>BURN AND CUTTING HAZARD!</p> <p>Open only when engine is stopped.</p>

17

 <p>DANGER</p> <p>When lock pin is not installed, do not stand under gantry.</p>
--

26

 <p>CAUTION</p> <p>Moving parts.</p>
--

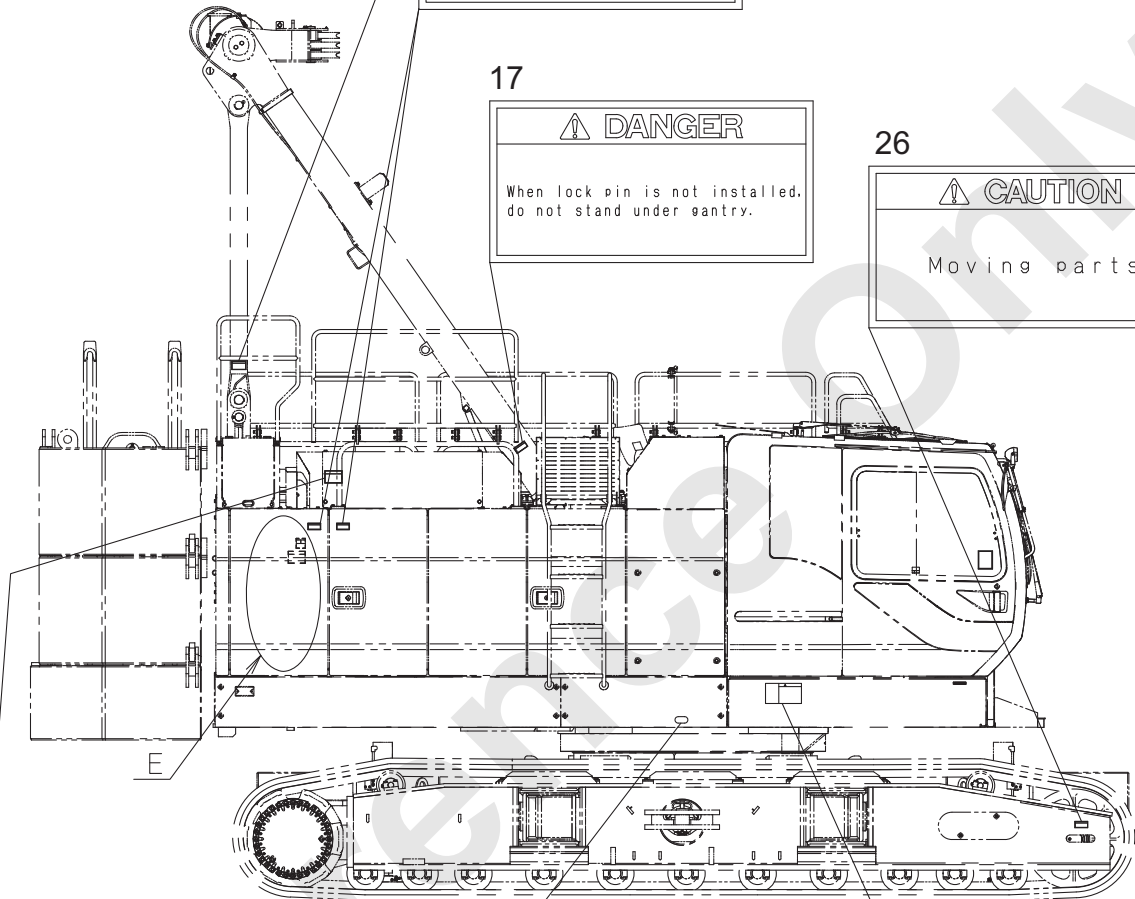



21

 <p>WARNING</p>  <p>BURN HAZARD!</p> <p>Do not touch. Allow to cool before touching.</p>
--

20

 <p>DANGER</p> <p>KEEP CLEAR OF SWING AREA</p>
--

6

 <p>DANGER</p> <p>ELECTROCUTION HAZARD</p> <p>THIS CRANE IS NOT INSULATED</p> <ul style="list-style-type: none"> ▣ To avoid death or serious injury, keep all parts of this crane, rigging and materials being lifted at least 20ft (6m) away from all electrical power lines and equipment. ▣ Keep away from this crane if it is being operated near electrical power lines or equipment. ▣ Before operating this crane in vicinity of power lines or equipment, notify power utility company. Have power turned off. ▣ Follow instructions in Operator's Manual. 	
---	--

24

⚠ DANGER	
 FALLING LOAD HAZARD!	Engage gantry pins when gantry is in high position Connect backhitch tension bars to rotating bed or counterweight when gantry is in low position

26

⚠ CAUTION
Moving parts.

17

⚠ DANGER
When lock pin is not installed, do not stand under gantry.

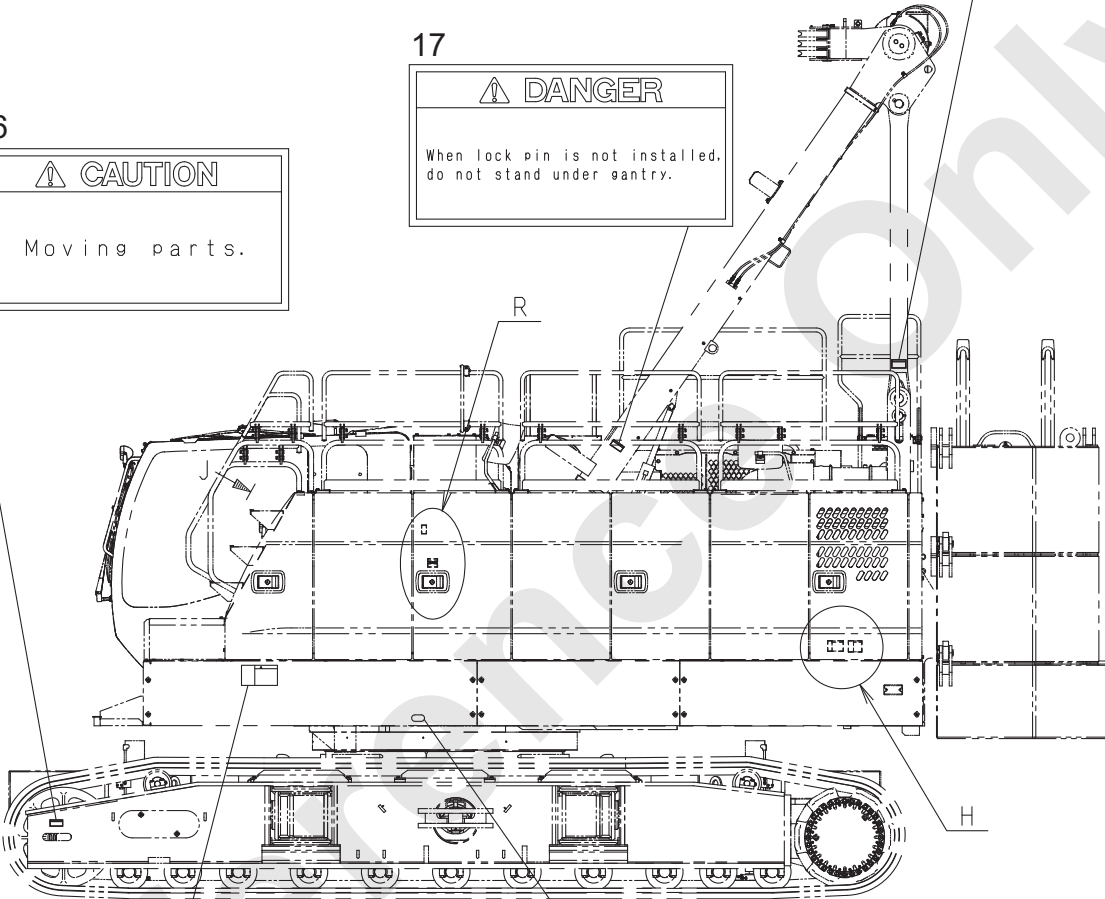

6

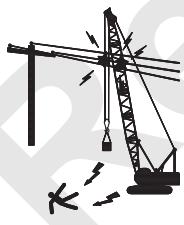
	⚠ DANGER
	<p style="text-align: center;">ELECTROCUTION HAZARD</p> <p style="text-align: center;">THIS CRANE IS NOT INSULATED</p> <ul style="list-style-type: none"> ▣ To avoid death or serious injury, keep all parts of this crane, rigging and materials being lifted at least 20 ft (6m) away from all electrical power lines and equipment. ▣ Keep away from this crane if it is being operated near electrical power lines or equipment. ▣ Before operating this crane in vicinity of power lines or equipment, notify power utility company. Have power turned off. ▣ Follow instructions in Operator's Manual.

20

⚠ DANGER
KEEP CLEAR OF SWING AREA

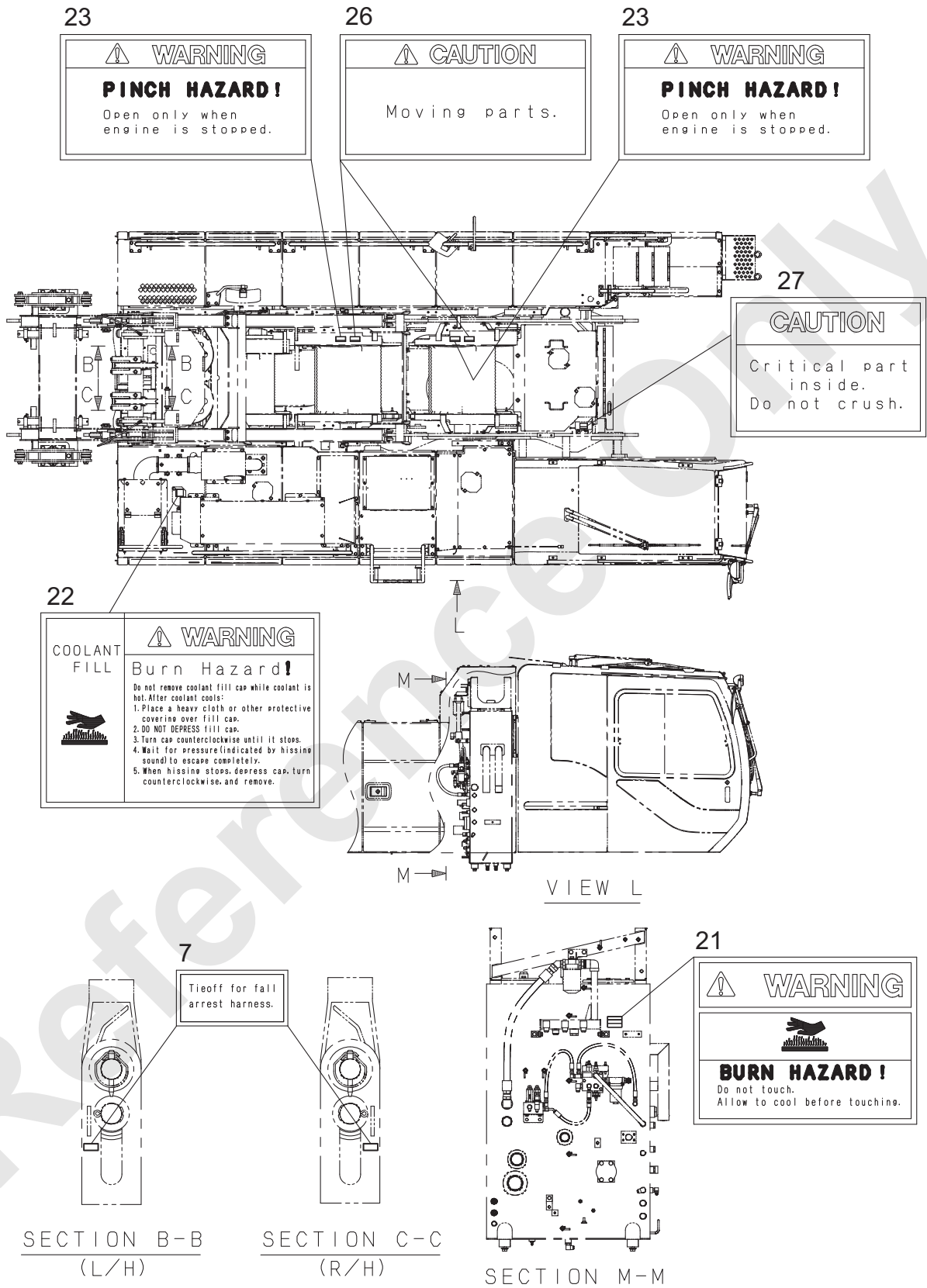

DETAIL H
(BATTERY)

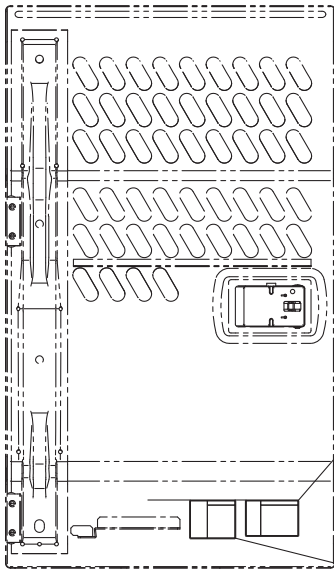

12

	⚠ WARNING
	<p>PREVENT BATTERY EXPLOSION</p> <ul style="list-style-type: none"> • Batteries give off hydrogen gases that can explode and cause personal injury. • Keep sparks, open flames and cigarettes away from batteries. • Keep metallic articles away from batteries. • Keep all ventilation caps tightly secured. • Never check charge by placing metal articles across battery terminals. • Leave battery box open to improve ventilation when charging.

12

	⚠ WARNING
	<p>BURN HAZARD!</p> <ul style="list-style-type: none"> • Electrolyte can cause injury or blindness if it contacts skin or eyes. • Wear eye protection and protective clothing when handling or servicing batteries. • If electrolyte contacts skin or eyes, flush affected areas immediately with clean water and seek medical attention immediately.

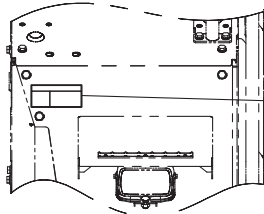

VIEW J

19

	⚠ WARNING
	<p>FALL HAZARD!</p> <p>Surface may be slippery. Wear work positioning harness and tieoff when performing maintenance.</p>

15 (10000E-1)

	ULTRA LOW SULFUR FUEL
--	-----------------------

15 (10000-1/11000-1 w/ J08E-UV)

FUEL TANK
⚠ CAUTION
ULTRA LOW SULFUR FUEL ONLY

16 (10000-1/11000-1 w/ J08E-VM)

	DIESEL FUEL
--	-------------

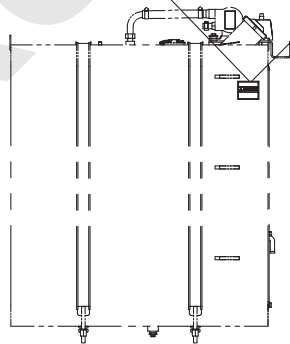

DETAIL R
(FUEL TANK)

25

⚠ WARNING	
Rotating parts can cause personal injury.	
Keep away from fan and belt when engine is running.	
Stop engine before servicing.	

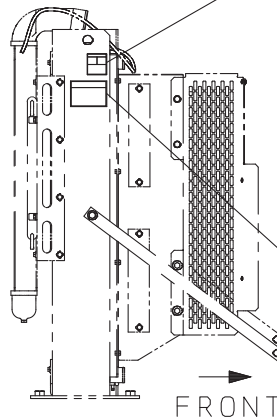

FRONT
DETAIL E
(RADIATOR)

21

	⚠ WARNING
	<p>BURN HAZARD!</p> <p>Do not touch. Allow to cool before touching.</p>

13

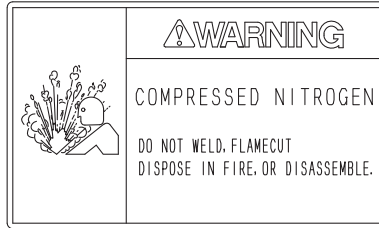

14

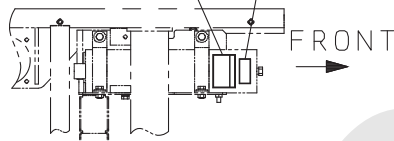
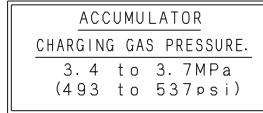

ACCUMULATOR

18 (10000-1/11000-1)

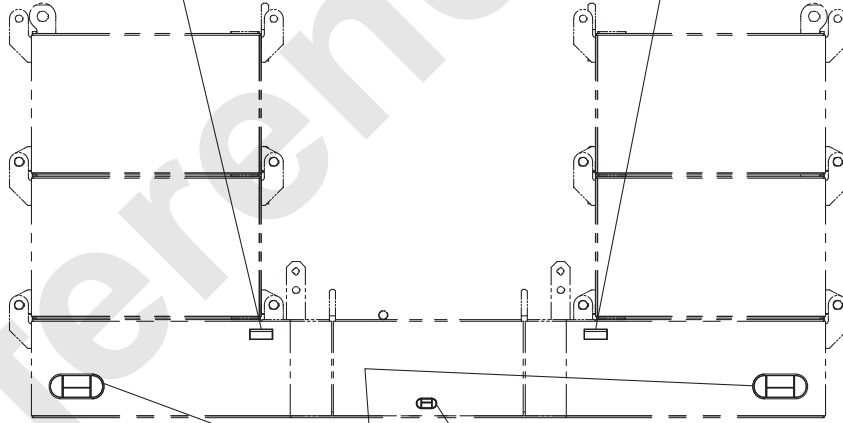
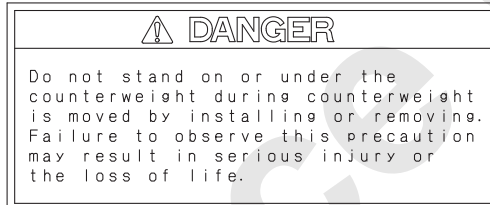

REAR VIEW

20 (10000-1/11000-1)

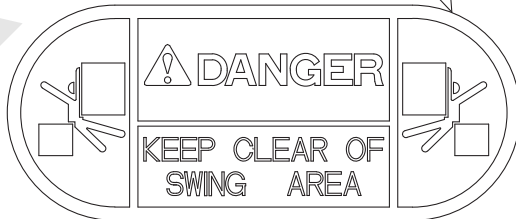

20 (10000-1/11000-1)



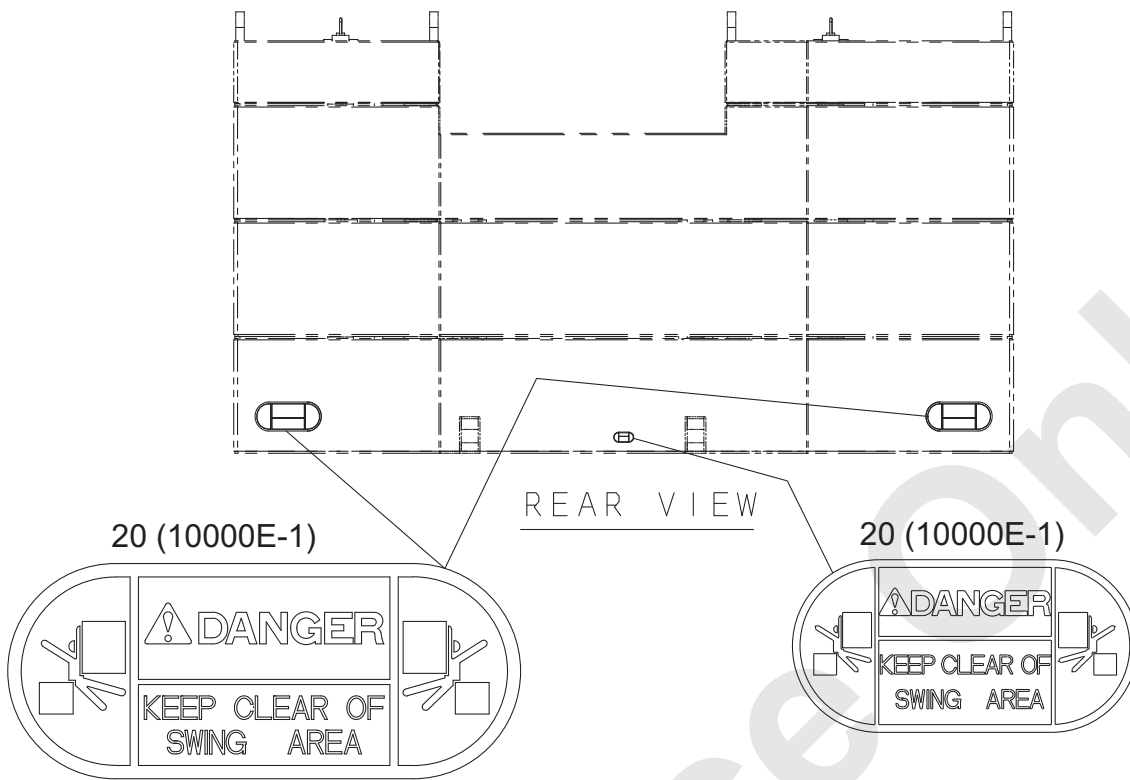

29

! CAUTION

**MOVING PARTS CAN CUT AND CRUSH
STRUCTURAL DAMAGE**

Place guides in storing position after connecting spreader to boom.
At first the guides should be held by hands and pins disengaged, and then should be placed in storing position.

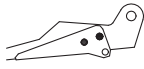

STORING POSITION

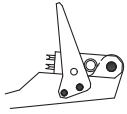

WORKING POSITION
(BOOM DISASSEMBLING
/ASSEMBLING)

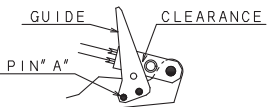

GUIDE CLEARANCE
PIN "A"
DISASSEMBLING
OF PIN "A"

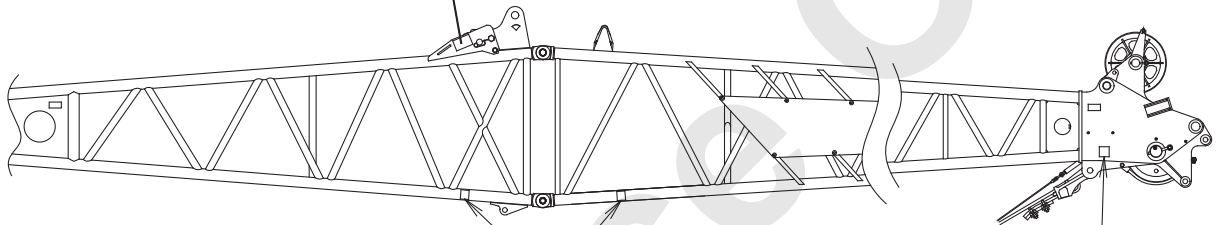

28

! DANGER

**DO NOT ENTER
UNDER BOOM**

TO AVOID SERIOUS INJURY
CAUSED BY FALLING OF BOOM,
DO NOT ENTER UNDER BOOM
WHILE DISASSEMBLING/
ASSEMBLING OF BOOM.



30 (10000-1/11000-1)

! CAUTION



Boom top
Boom foot

CORRECT

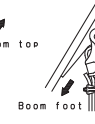

Boom top
Boom foot

WRONG

Install the rope socket in the correct direction.
Otherwise, the rope socket or the wire rope
may interfere with the boom, causing
damage to the boom or cut of the wire rope.

30 (10000E-1)

! CAUTION



Boom top
Boom foot

CORRECT



Boom top
Boom foot

WRONG

Install the rope socket in the correct direction.
Otherwise, the rope socket or the wire rope
may interfere with the boom, causing
damage to the boom or cut of the wire rope.

SAFETY

1. Ensure to read the operators manual before operation / handling, assembly, / disassembly, transportation, inspection / maintenance of the machine.

	⚠ WARNING
	<ul style="list-style-type: none">• To prevent death or serious injury.• Avoid unsafe operation or maintenance.• Do not operate or work on this crane without first reading and understanding operator's manual and capacity charts.• Keep manual in operator's cab.• Attach Capacity charts to chain and store on hook provided in operator's cab.• If operator's manual or capacity charts are lost, contact your nearest dealer for new ones.

2. If the free fall speed select switch is in speed increase side and the brake is released and the drum may rotate automatically to lowering side even without lifting load and wire rope may be paid out to lower the hook and rough spooling may be caused.
When paying out the wire rope from the drum, ensure to set the free fall select switch to normal side.

⚠ CAUTION
SET FREE FALL INCREASED SELECTOR SWITCH TO "LOCK" POSITION WHEN REEVING WIRE ROPE.
DRUM AUTOMATICALLY ROTATES WITHOUT LOAD WHEN BRAKE IS RELEASED WITH FREE FALL INCREASED SELECTOR SWITCH SET TO "RELEASE" POSITION.

3. The crane may turn over during work based on machine condition.
Install the proper amount of the counterweight and secure them to make proper machine configuration.

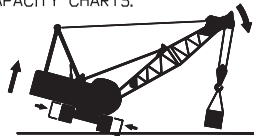
⚠ DANGER
TIPPING HAZARD! DO NOT LIFT WITH CRAWLERS RETRACTED
EXTEND CRAWLERS TO PROPER POSITION BEFORE LIFTING. COMPLY WITH LIMITATIONS GIVEN IN CAPACITY CHARTS.

4. If machine swings or is assembled / disassembled with crawler retracted, main machinery may turn over to rear side.
Read the operator's manual carefully and set the crane to the proper configuration.

⚠ DANGER
TIPPING HAZARD! When Operating with Retracted Crawlers
• DURING SETUP - do not swing over retracted crawlers with boom removed (or just boom butt installed) and counterweights installed.
• DURING OPERATION - comply with swing limitations given in Capacity chart.

5. If the brake pedal lock is not completely engaged, lifting load or hook may be lowered unexpectedly and is very dangerous.
When locking the brake pedal, press the brake pedal fully and confirm that the pedal is locked completely.

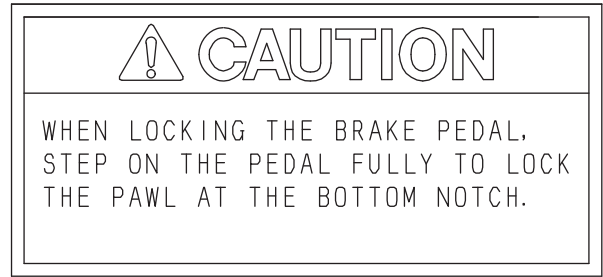

6. During crane work if the boom comes too close to the tower or power lines, electric shock may hit the crane.
Keep the boom away from the tower or power lines for safety.

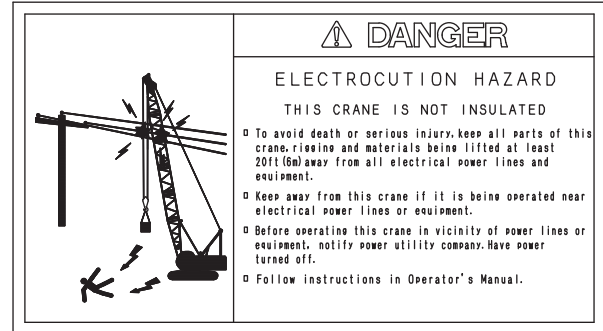

7. When work is done on the upper surface of the guard or counterweight, person may fall off by mistake.
Ensure to engage the safety hook on the specified place.



SAFETY

8. When the boom is assembled, disassembled, boom self erection / self lowering or crane work with the low gantry, the gantry or boom may be damaged and may fall off.
Raise the gantry to the proper position for work.

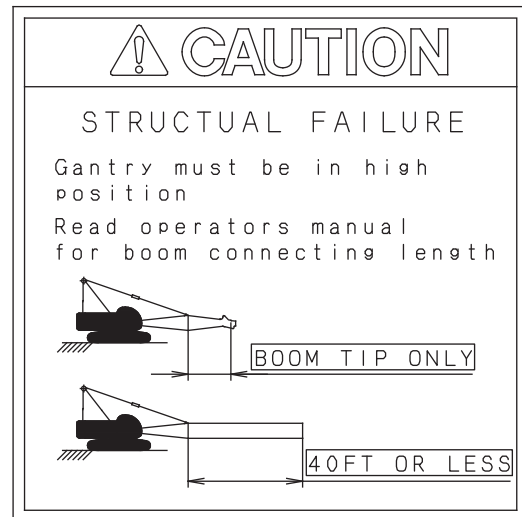

9. Free fall work of load may cause dropping the load by mishandling.
Use power lowering of load in the crane work.
(Even on neutral free side, power lowering is possible by turning the lever to lowering side.)

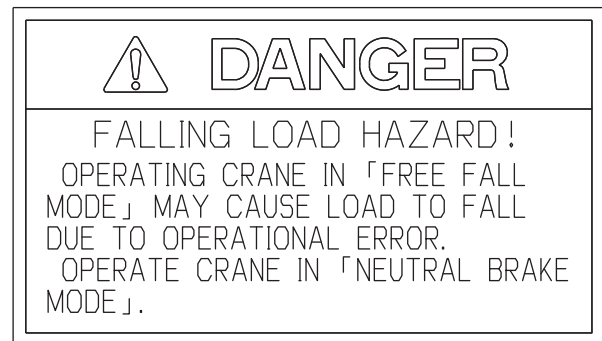

10. This machine contains alloy and heat treated steels.
Do not weld or apply heat without checking with your authorized dealer.
Unauthorized modifications may weaken the machine.

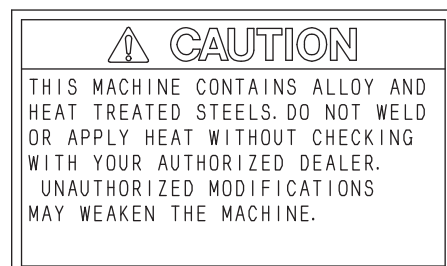

11. Do not lift people with this crane.
Failure to do so may cause serious injury.

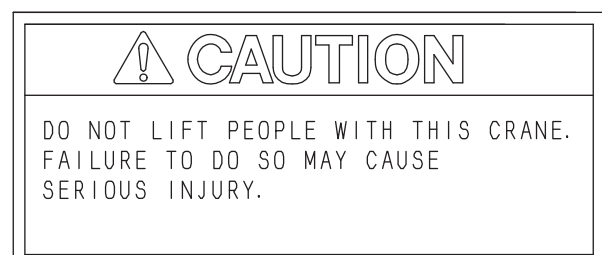

12. Wrong handling of battery may cause burns, blindness or explosion by inflammation.

	<p>⚠WARNING</p>
	<p>BURN HAZARD!</p> <ul style="list-style-type: none"> ·Electrolyte can cause injury or blindness if it contacts skin or eyes. ·Wear eye protection and protective clothing when handling or servicing batteries. ·If electrolyte contacts skin or eyes, flush affected areas immediately with clean water and seek medical attention immediately.

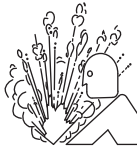
	<p>⚠WARNING</p>
	<p>PREVENT BATTERY EXPLOSION</p> <ul style="list-style-type: none"> ·Batteries gives off hydrogen gases that can explode and cause personal injury. ·Keep sparks, open flames and cigarettes away from batteries. ·Keep metallic articles away from batteries. ·Keep all ventilation caps tightly secured. ·Never check charge by placing metal articles across battery terminals. ·Leave battery box open to improve ventilation when charging.

13. If accumulator is handled in wrong way, burns, loss of eyesight, explosion may be caused.
Take extra care in handling accumulator.
(Do not weld, flame cut, dispose or disassemble.)

	<p>⚠WARNING</p>
	<p>COMPRESSED NITROGEN</p> <p>DO NOT WELD, FLAMECUT DISPOSE IN FIRE, OR DISASSEMBLE.</p>

14. The accumulator is charged with high pressure nitrogen gas.
Charge the nitrogen gas within the specified pressure.

<p>ACCUMULATOR</p> <p>CHARGING GAS PRESSURE.</p> <hr style="width: 50%; margin: auto;"/> <p>3.4 to 3.7 MPa (493 to 537 psi)</p>

SAFETY

15. Using the engine fuel other than the specified diesel fuel may cause engine failure, fire or explosion.
Ensure to use the diesel fuel in the fuel tank.
Use ultra low sulfur diesel fuel only.
(S50 : sulfur content lower than 50 ppm)

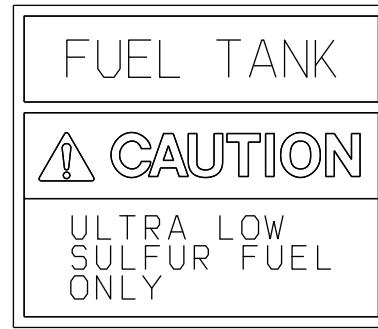

16. Using the engine fuel other than the specified diesel fuel may cause engine failure, fire or explosion.
Ensure to use the diesel fuel in the fuel tank.
Use diesel fuel only.



17. During raising the gantry, ensure to insert the gantry fixing pin.
Otherwise the gantry may come off and the boom may drop off.

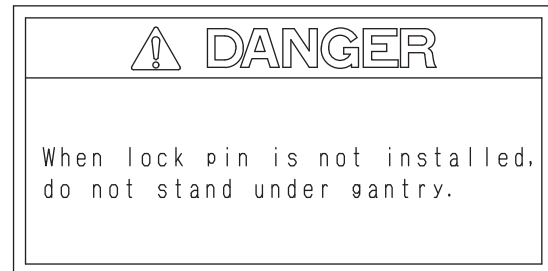

18. Handling the counterweight in wrong way is very dangerous.
Never allow any person to enter under the lifting counterweight.

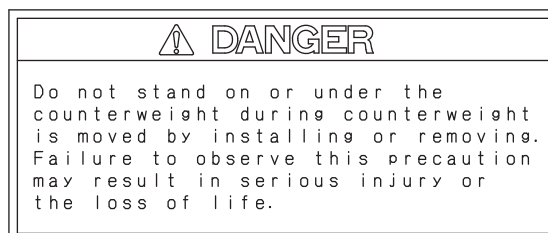

19. When working on the upper surface of the guard, person may fall off the upper surface of the guard. During high place work on the upper surface of the guard, do not come close to the guard side face to prevent falling off. During work on the upper surface of the guard, ensure to wear safety belt and hook the safety belt on the upper machinery and firmly stand on the guard.

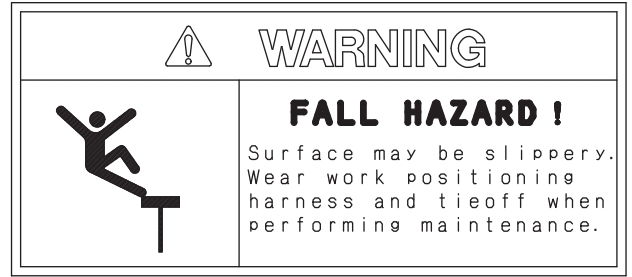

20. While the upper machinery is swinging, person may be crushed with the upper machinery. Never allow anybody to enter the swing range.

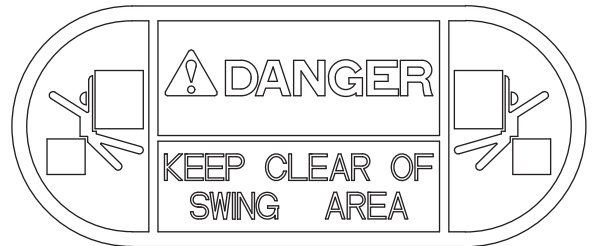
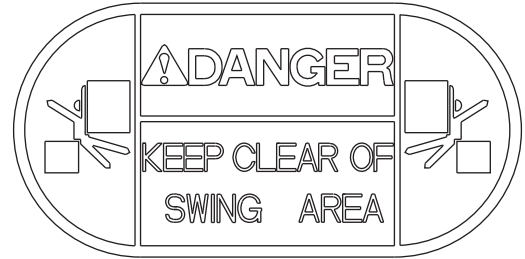

21. During engine running or straight after the engine is stopped, hydraulic oil tank, engine and muffler are hot. Touching them may cause burns. Do not touch the hot area.



SAFETY

22. During engine running or straight after the engine is stopped, inside of the radiator becomes high pressure and hot.
 Person may get burns by hot water blow out when taking off the radiator cap.
 Take extra care of opening or closing of the radiator cap.

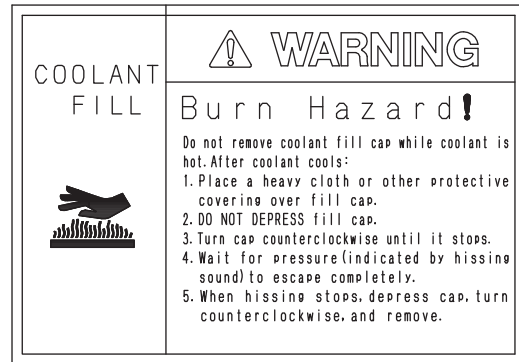

23. When inspection or work is done by removing the drum flange cover, serious injuries may be caused if the drum rotates unexpectedly.
 Stop the crane and then remove the drum cover.



24. When the machine is transported with the low gantry, connect the tension bar to the revolving frame or counterweight.

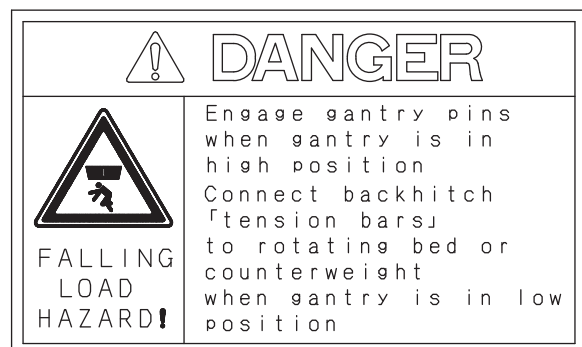

25. When working on the engine area for inspection and maintenance, person may be entangled with the fan belt and may get injured if the engine is running.
Stop the engine when inspection or maintenance work is done.

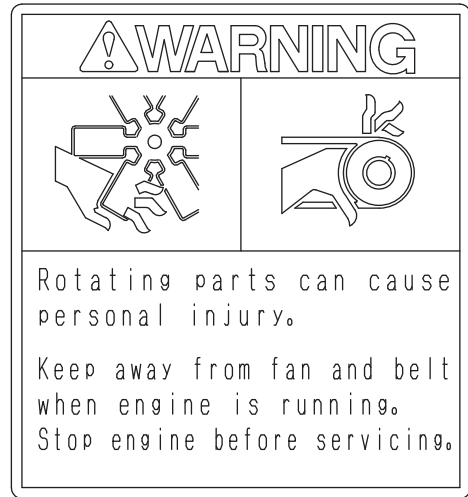

26. There are some moving parts near.

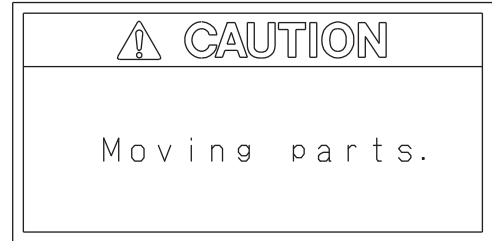

27. This is a connector cover of electrical wiring of safety device.
Do not step on and crush.

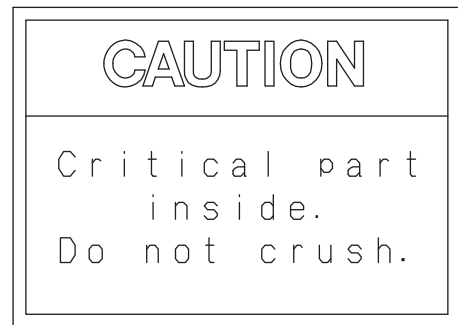

28. Taking wrong procedure in boom assembly or disassembly may cause boom falling off and person may get injured.
Do not allow any person to enter the inside or under the boom during assembly or disassembly.



SAFETY

29. Taking wrong method in using the spreader guide installed on the boom base may damage the spreader guide.

Set the spreader guide to the stowing position except when the upper spreader is connected is connected to the boom base.

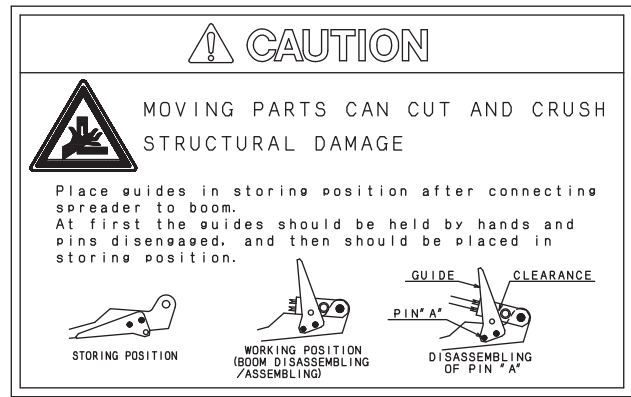

30. Taking the wrong installing direction when the rope sockets are installed to the boom tip and jib tip, may damage the boom or may break the wire rope. Install the rope socket in the proper direction.

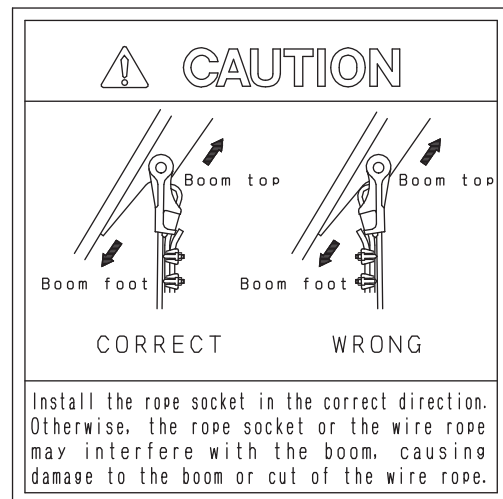
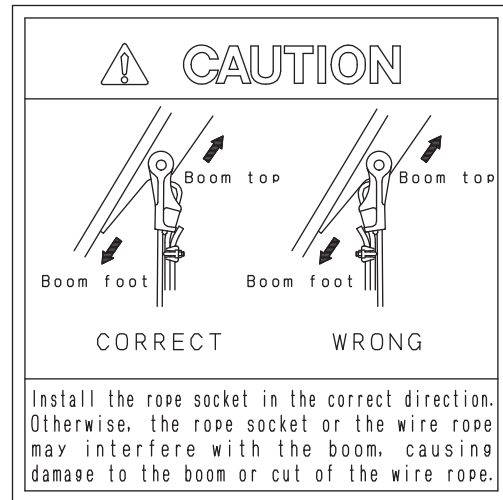

31. Free fall work of load may cause dropping the load by mishandling.
Use power lowering of load in the crane work.
(Even on neutral free side, power lowering is possible by turning the lever to lowering side.)

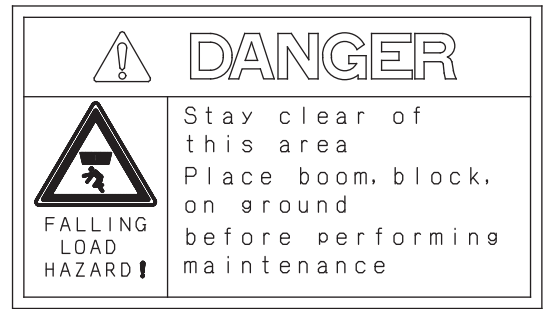

32. Simultaneous control of the front and the rear drum may results in serious accident.
European regulation (EN13000) do not allow simultaneous control of the front and the rear drum.

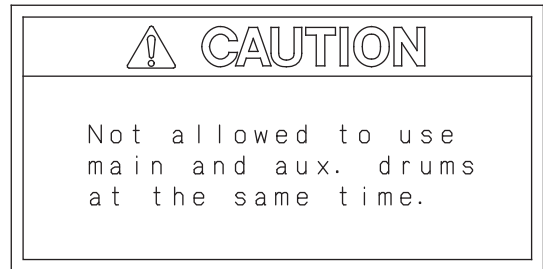

CAUTION LABEL

- Keep the caution label in good condition to read.
- Whenever they become dirty, wash them with water or detergent.
- Whenever they are damaged or missed, replace them with the new and same ones.

Referer

PRECAUTIONS FOR INSPECTION AND MAINTENANCE

1. Service and maintenance must be performed only by authorized personnel who are qualified in compliance with a relevant law or regulation.
2. Regular maintenance or inspection should be quickly performed after shutting down the machine and ensuring safety to personnel and equipment.
Post an "INSPECTION IN PROGRESS. DO NOT START." warning sign on a readily visible location.

GENERAL SAFETY PRECAUTIONS

1. Wear safety shoes, helmets and clothing suitable for the job. Also use protective goggles, mask, gloves, etc., as required.
2. To ensure safe and correct maintenance, carefully study this SHOP MANUAL and get fully familiar with the instructions in it.
3. Place the machine in a safe place. Always maintain safe clearance around the machine.
4. Before starting crane operation, hold a safety meeting. Also, make agreement on standardized hand signals.
5. When inspecting or handling the battery or oil, do not use exposed flame nearby.
To avoid fire accident, only use explosion-proof lighting equipment.
6. Start an inspection or maintenance work only after shutting down the engine.
7. Certain machine components remain hot immediately after the engine is shut down. Do not touch them.
8. Before removing the radiator cap, wait until the coolant water gets sufficiently cool. Next, carefully loosen the cap and release radiator pressure, and then remove the cap.
9. Before inspecting or maintaining an electrical system on the machine, turn the power off the machine by, for example, disconnecting the battery cables.
10. When working at a high lift area, always wear a safety belt.
11. When leaving the operator's cab for an inspection or maintenance work, post an "INSPECTION IN PROGRESS. DO NOT START." warning sign on a readily visible location. Also, lock the cab for security.
12. Before starting a cleaning or lubrication work on the machine, always shut down the engine.
13. Use genuine Manitowoc replacement parts and oils only.
14. Always keep the oil containers clean. Protect them against ingress of dust or moisture. Also, fill clean, fresh oils only.
15. Once a maintenance work is complete, clean the machine.
Protect grease nipples, breathers, and oil level gages against ingress of dust.
16. Clean the inspection area to allow detecting faulty such as oil leak, crack or looseness easily if existed.
17. During car washing, do not allow high pressure steam to be directly applied to electrical components and connectors.
18. After removing O-rings, oil seals, gaskets, etc., clean the mounting seats. Then, install new O-rings, oil seals, gaskets, etc. Also, ensure to thinly apply oil to the seal faces of these parts before installation.
19. Before disconnecting pressurized piping, release the inside pressure.
20. CAUTIONs for repair work with welding: Turn OFF the key switch and disconnect the negative terminal on battery to power off the electrical circuit. Provide grounding within 1 meter from a weld area and remove electronic components (for example, controller) to prevent possible damage.
21. Dispose industrial wastes according to a relevant law or regulation.
22. Be extremely careful during an inspection or maintenance work under the carrier. Remember the possibility of being crashed.
When jacking up the machine for an inspection or maintenance work, place blocks below to prevent accidental falling.
23. Provide positive ventilation when refilling oils or fuel, rinsing parts, or starting the engine.
24. To remove a heavy component (20kg or heavier), use a crane, etc. Always keep safety in mind.

25. Illegal, unauthorized, or nonconforming modification is strictly prohibited.
26. Do not allow oil or dust to deposit around the engine. Otherwise, fire accident can result.
Clean the oil or dust adhered to.
27. Place removed attachments and components safely so that they do not drop or fall down.
28. Always use correct tools that have been well maintained.
29. To prevent personnel from being caught by a running fan, belt, shaft etc, shut down the engine before starting an inspection or maintenance work.
30. Battery fluid and oils are harmful to human health. If touching any of these materials, immediately wash it away.
31. When lifting a load with a crane, first confirm that a load is lifted off the ground surely and then continue lifting work.

Reference Only

Reference Only

1. REFERENCE MATERIALS

Reference Only

Reference Only

1.1 10000-1/11000-1 SPECIFICATION

1.1.1 CRANE OUTER DIMENSION

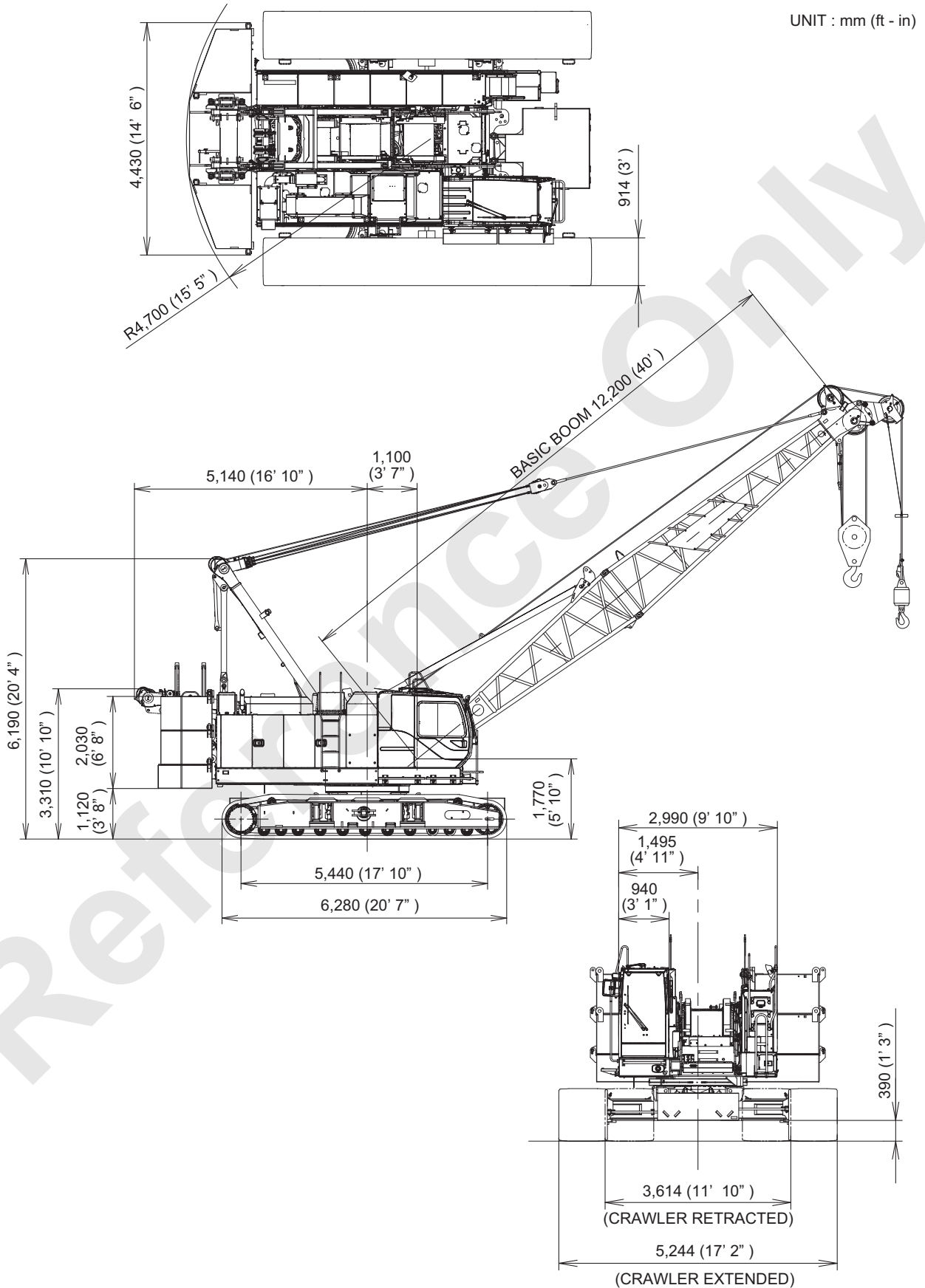

1. REFERENCE MATERIALS

1.1.2 CRANE SPECIFICATION, PERFORMANCE

Type		Full swing, crawler type		
Max. rated load × work radius		99.8 t × 3.35 m (220,000 lbs × 11 ft)		
Boom length	Basic boom	12.2 m (40 ft)		
	Maximum boom	61.0 m (200 ft)		
	Crane jib	9.1 m (30 ft) to 18.3 m (60 ft)		
	Maximum boom and jib	57.9 m (190 ft) Boom + 18.3 m (60 ft) Jib		
Work speed (wire rope)	Front / rear hoisting rope speed	120 to 3 m/min (390 to 10 ft/min)	Wire rope dia.	26 mm
	Front / rear lowering rope speed	120 to 3 m/min (390 to 10 ft/min)		
	Boom raising rope speed	70 to 2 m/min (230 to 6.6 ft/min)		16 mm
	Boom lowering rope speed	70 to 2 m/min (230 to 6.6 ft/min)		
	Third hoisting rope speed (Option)	120 to 3 m/min (390 to 10 ft/min)		22 mm
	Third lowering rope speed (Option)	120 to 3 m/min (390 to 10 ft/min)		
	Swing speed	4.0 min ⁻¹ (4.0 rpm)		
	Propel speed	1.7/1.1 km/h (1.1/0.72 mph)		
Gradability		40%		
Working weight *1		90.0 t (198,000 lbs)		
Average ground pressure *1		88.9 MPa (12.9 psi)		
Engine	Engine name	Hino J08E-UV OR Hino J08E-VM		
	Engine out put	213 kW/2,100 min ⁻¹ (286 HP/2,100 rpm)		

*1 Crane (12.2 m (40 ft), Without rear drum rope, Without main hook)

1. Each rope speed varies based on load.
2. Each rope speed is the value of the drum first layer's one.

OUTSIDE DIMENSIONS

Unit : mm (ft-in)

Overall width of cab	2,990 (9' 10")
Radius of rear end (counterweight)	4,700 (15' 5")
Center of rotation to rear end (Low gantry position)	5,140 (16' 10")
Center of rotation to boom foot pin (from center of rotation)	1,100 (3' 7")
Height from ground to boom foot pin	1,770 (5' 10")
Height to top of gantry (Working position)	6,190 (20' 4")
Height to top of gantry (Low gantry position)	3,310 (10' 10")
Counterweight ground clearance	1,120 (3' 8")
Overall length of crawlers	6,280 (20' 7")
Distance between centers of tumblers	5,440 (17' 10")
Overall width of crawlers (Extend/Retract)	5,244 / 3,614 (17' 2" / 11' 10")
Width of crawler shoe	914 (3')
Ground clearance of carbody	390 (1' 3")

1.1.3 CRANE WORKING RANGES

1. CRANE WORKING RANGES

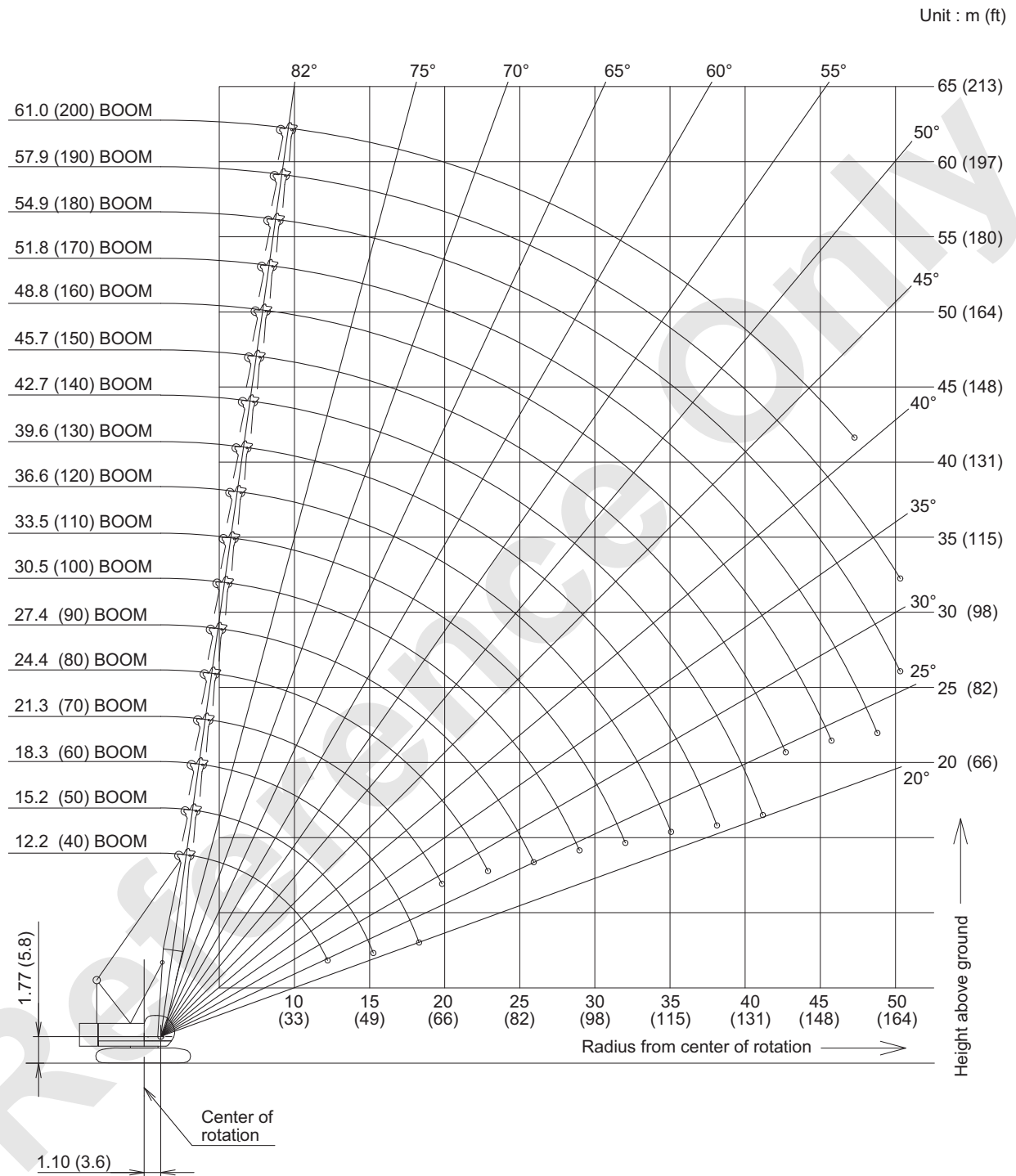

1. REFERENCE MATERIALS

2. JIB WORKING RANGE

(1) Offset angle 10 degrees

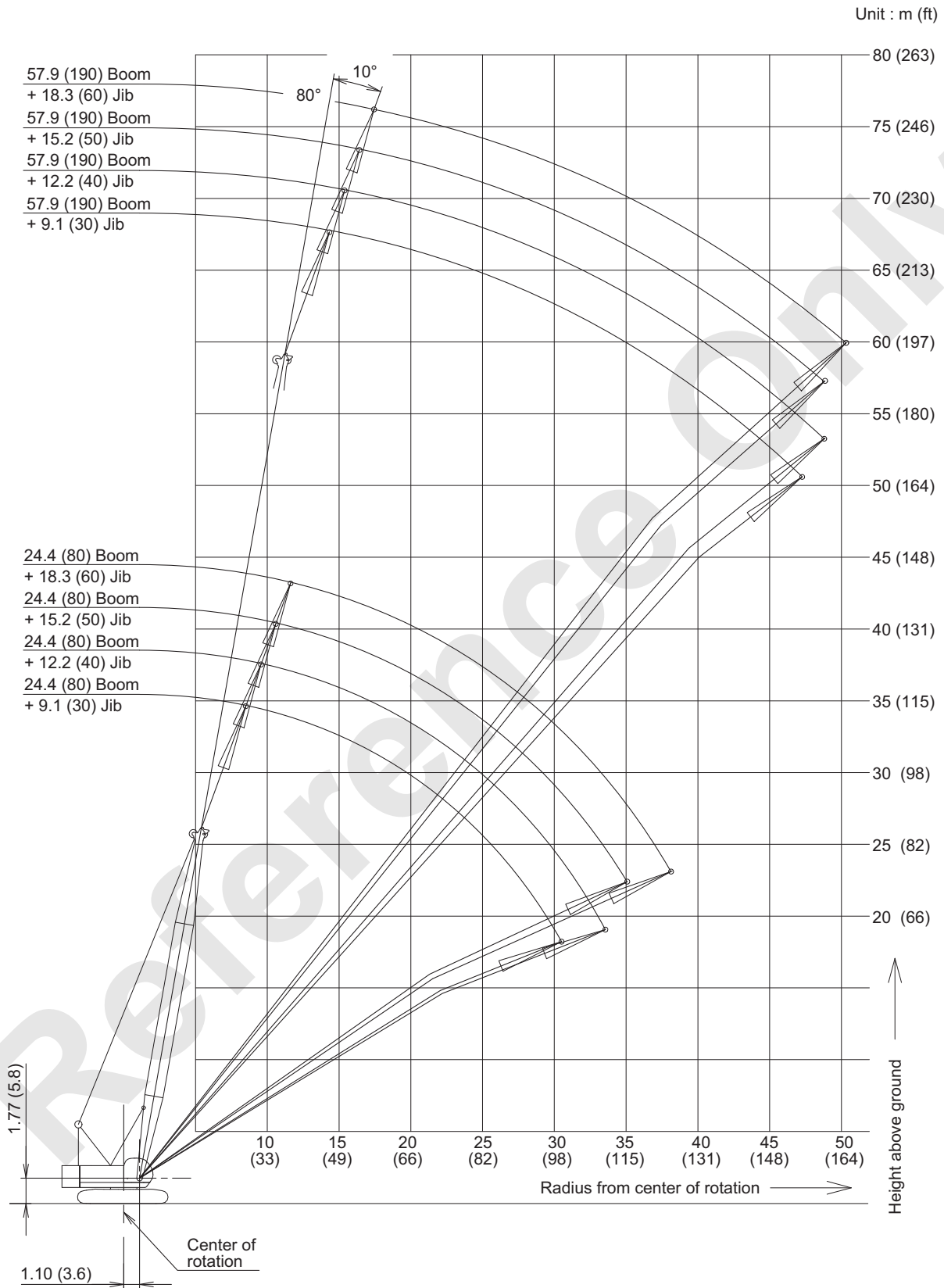

(2) Offset angle 30 degrees

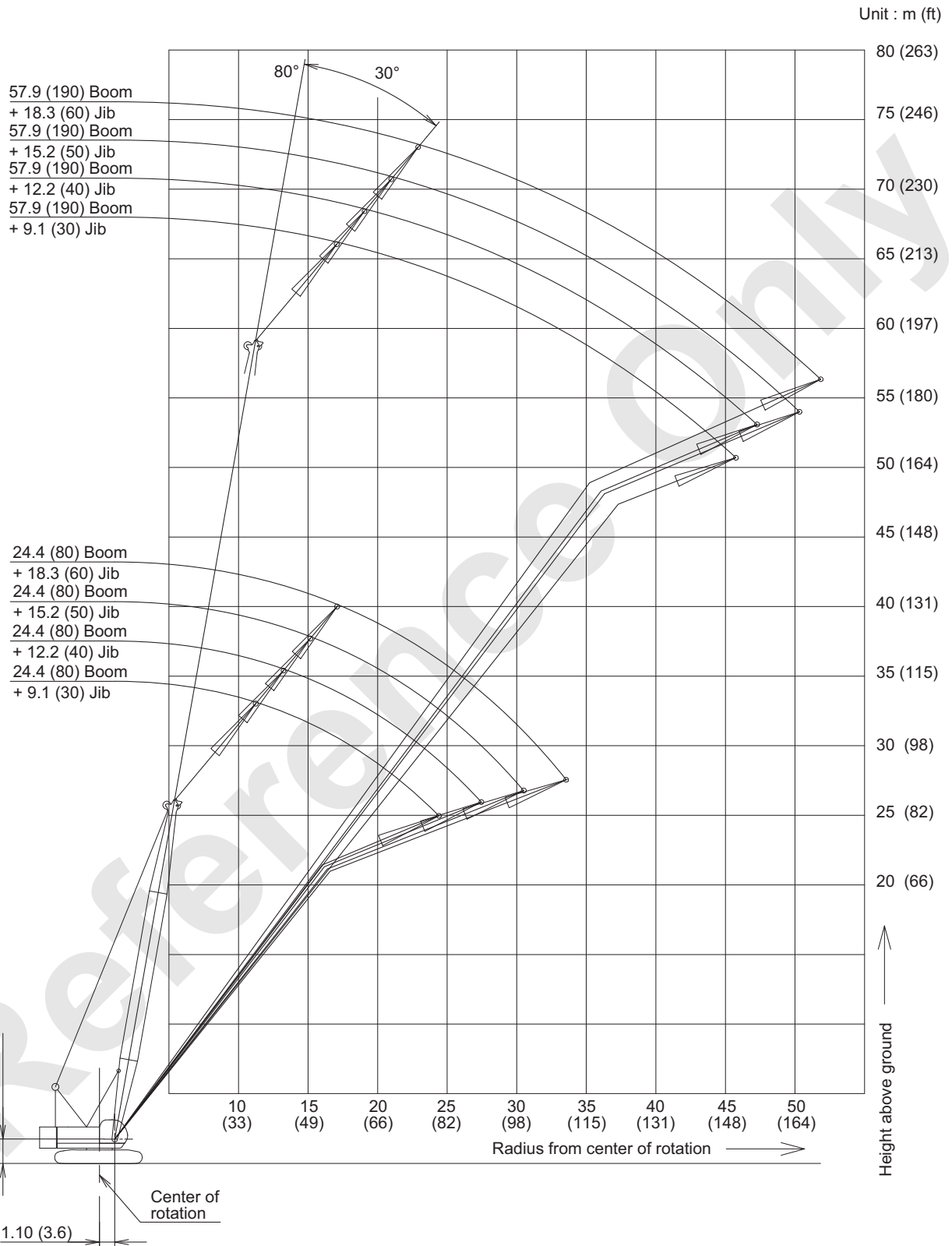

1. REFERENCE MATERIALS

1.2 10000-1/11000-1 DIMENSION, WEIGHT OF EACH COMPONENT

Dimension and weight of each component when disassembled is shown here.

Use this as reference value.

1.2.1 MAIN MACHINERY

Name	Dimension mm (ft-in)	Weight kg (lbs)
Base Machine <ul style="list-style-type: none"> • Boom base • Gantry • Crawler • Wire rope (Front / rear / boom hoist) 		43,150 (95,128)
Base Machine <ul style="list-style-type: none"> • Gantry • Crawler • Wire rope (Front / rear / boom hoist) • Without boom base 		41,090 (90,586)
Base Machine <ul style="list-style-type: none"> • Gantry • Crawler • Wire rope (Front / rear / boom hoist) • Without boom base • Self removal unit 		40,220 (88,668)
Base Machine <ul style="list-style-type: none"> • Boom base • Gantry • Wire rope (Front / rear / boom hoist) • Without crawler • Without side steps 		27,870 (61,442)
Base Machine <ul style="list-style-type: none"> • Gantry • Wire rope (Front / rear / boom hoist) • Without Crawler • Without Boom base • Without side steps 		25,810 (56,900)
Crawler		7,640 (16,843)

*1 With the side step on cabin side : 3,170 (10' 5")
 With the side steps on the both side : 3,340 (11')

1.2.2 COUNTERWEIGHT

Name	Dimension mm (ft-in)	Weight kg (lbs)
No.1 Counterweight		8,310 (18,300)
No.2, No.3 Counterweight (R)		5,750 / 1 piece (12,680)
No.2, No.3 Counterweight (L)		5,750 / 1 piece (12,680)
Carbody weight		7,240 (15,960)

1. REFERENCE MATERIALS

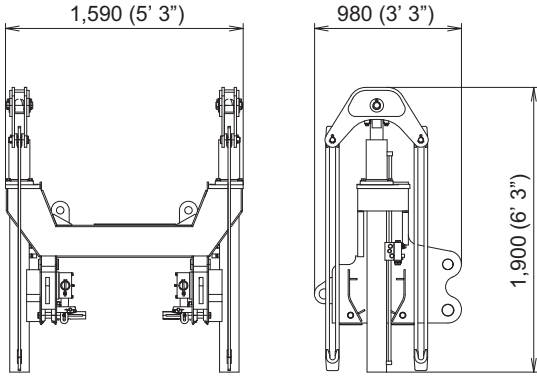
Name	Dimension mm (ft-in)	Weight kg (lbs)
Self removal unit		870 (1,918)

1.2.3 ATTACHMENT

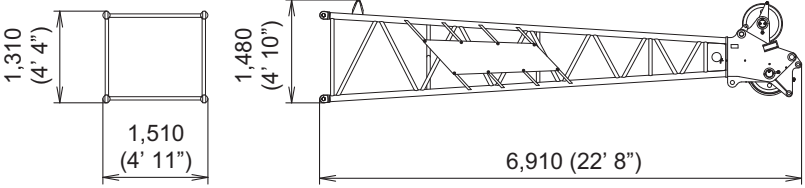
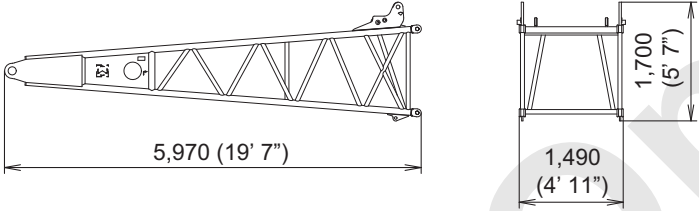
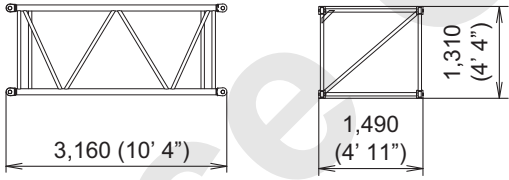
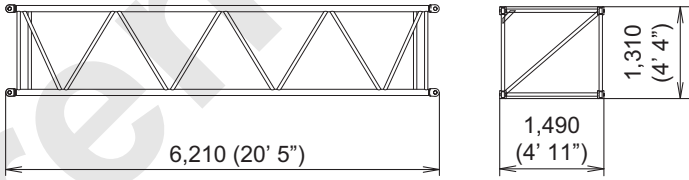
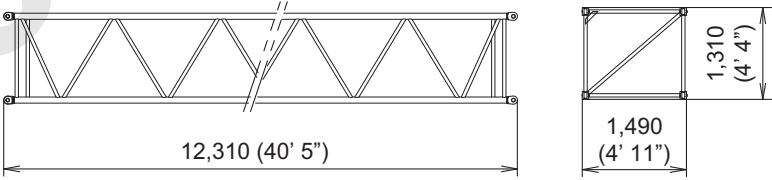
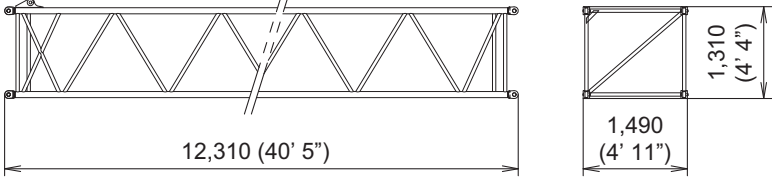
Name	Dimension mm (ft-in)	Weight kg (lbs)
Boom tip		1,170 (2,580)
Boom base		1,475 (3,252)
3.0m (10ft) Boom insert		310 (685)
6.1m (20ft) Boom insert		520 (1,145)
12.2m (40ft) Boom insert		960 (2,115)
12.2m (40ft) Boom insert with lug		975 (2,150)

1. REFERENCE MATERIALS

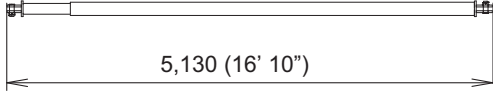
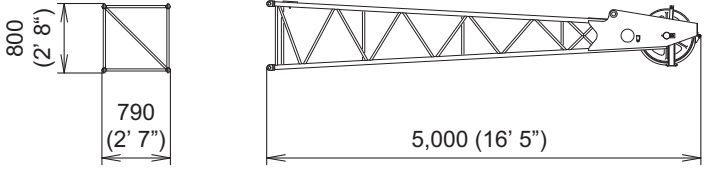
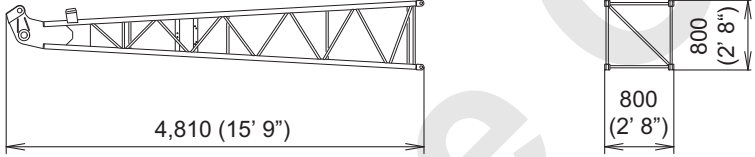
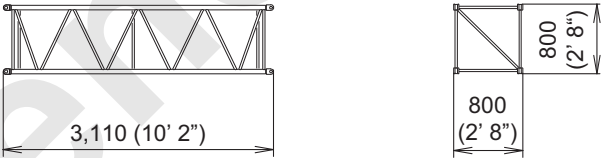
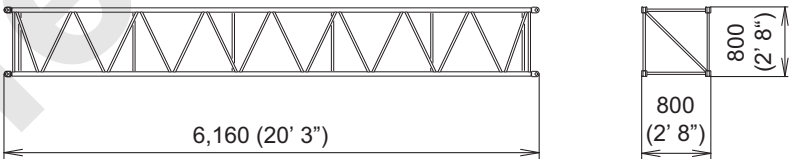
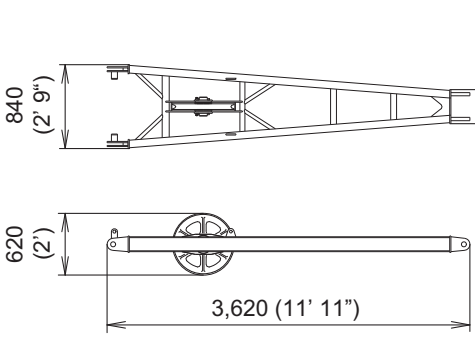
Name	Dimension mm (ft-in)	Weight kg (lbs)
Backstop		270 (595)
Jib tip		280 (617)
Jib base		200 (440)
3.0m (10ft) Jib insert		100 (220)
6.1m (20ft) Jib insert		180 (395)
Jib strut		250 (550)

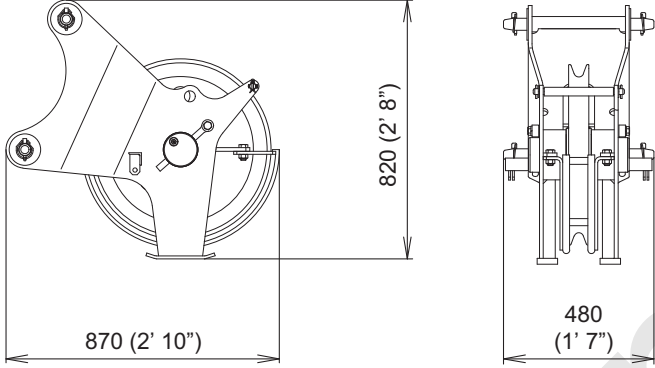
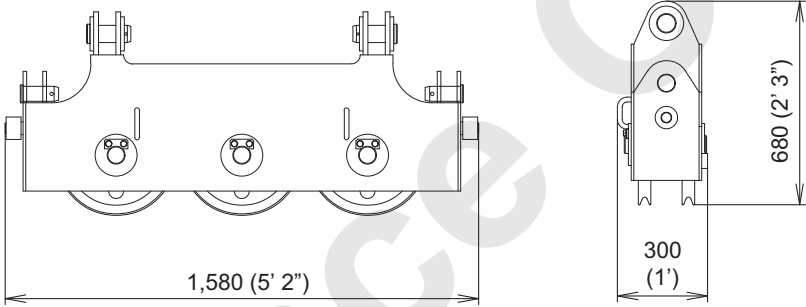
Name	Dimension mm (ft-in)	Weight kg (lbs)
Auxiliary sheave		195 (430)
Upper spreader		235 (518)

1. REFERENCE MATERIALS

1.3 10000-1/11000-1 SWING AND PROPEL STABILITY

1. Without carbody weight

Attachment	Counterweight ton (lbs)	All-round swing		Propelling on slope	
		Crawler extend	Crawler retract	Forward	Backward
Without attachment (Base machine only)	0 (Without)	○	○	○	○
	8.31 (18,320) (No.1)	○	△ (No abrupt lever control)	○	○
	19.81 (43,674) (No.1 to No.2)	△ (No abrupt lever control)	×	×	○
	31.31 (69,028) (No.1 to No.3)	×	×	×	×
With boom base (Boom angle : 10 degrees or less)	0 (Without)	○	○	○	○
	8.31 (18,320) (No.1)	○	○	○	○
	19.81 (43,674) (No.1 to No.2)	○	×	×	○
	31.31 (69,028) (No.1 to No.3)	×	×	×	×
With basic boom (Boom angle : 30 degrees or less)	0 (Without)	○	○	○	○
	8.31 (18,320) (No.1)	○	○	○	○
	19.81 (43,674) (No.1 to No.2)	○	×	△ (Slope:7 deg. or less)	○
	31.31 (69,028) (No.1 to No.3)	△ (No abrupt lever control)	×	×	△

○ : Able to be operated
 △ : Able to be operated with conditions
 × : Unable to be operated

- (1) The table above shows the values for operation on a firm ground.
 On a weak ground, operate with care after curing the ground.
- (2) As a principle, swinging on a trailer is prohibited.
- (3) Maximum slope angle is 21.8 degrees (40%).
 This may become lower depending on condition (ground, crane configuration).
- (4) Travelling forward means the case where the counterweight is at the lower slope and the traveling backward where it is at the upper slope.

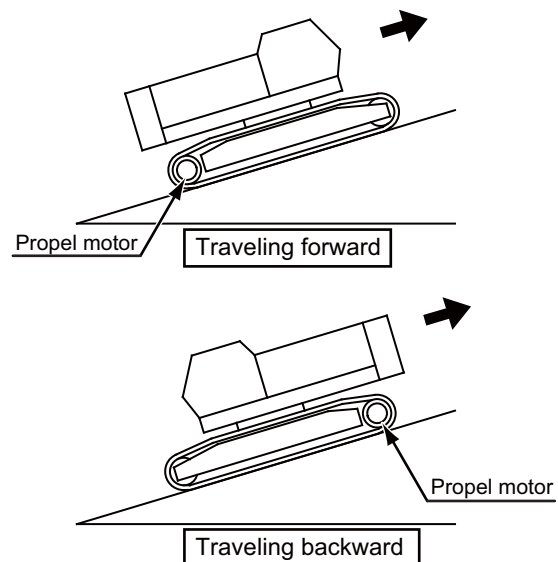

2. With carbody weight

Attachment	Counterweight ton (lbs)	All-round swing		Propelling on slope	
		Crawler extend	Crawler retract	Forward	Backward
Without attachment (Base machine only)	0 (Without)	○	○	○	○
	8.31 (18,320) (No.1)	○	○	○	○
	19.81 (43,674) (No.1 to No.2)	○	×	△ (Slope:8 deg. or less)	○
	31.31 (69,028) (No.1 to No.3)	△ (No abrupt lever control)	×	×	△
With boom base (Boom angle : 10 degrees or less)	0 (Without)	○	○	○	○
	8.31 (18,320) (No.1)	○	○	○	○
	19.81 (43,674) (No.1 to No.2)	○	×	△ (Slope:12 deg. or less)	○
	31.31 (69,028) (No.1 to No.3)	△ (No abrupt lever control)	×	×	△
With basic boom (Boom angle : 30 degrees or less)	0 (Without)	○	○	○	○
	8.31 (18,320) (No.1)	○	○	○	○
	19.81 (43,674) (No.1 to No.2)	○	△ (No abrupt lever control)	○	○
	31.31 (69,028) (No.1 to No.3)	○	×	△ (Slope:3 deg. or less)	○

○ : Able to be operated
 △ : Able to be operated with conditions
 × : Unable to be operated

- (1) The table above shows the values for operation on a firm ground.
 On a weak ground, operate with care after curing the ground.
- (2) As a principle, swinging on a trailer is prohibited.
- (3) Maximum slope angle is 21.8 degrees (40%).
 This may become lower depending on condition (ground, crane configuration).
- (4) Travelling forward means the case where the counterweight is at the lower slope and the traveling backward where it is at the upper slope.

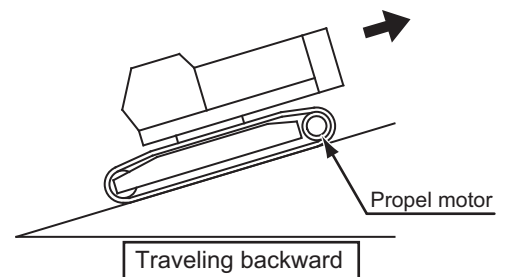
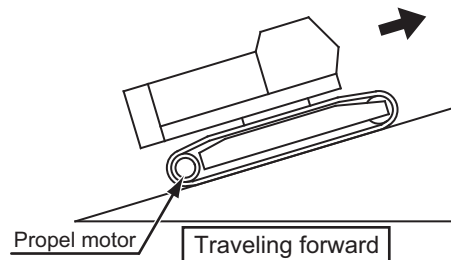

1. REFERENCE MATERIALS

1.4 10000-1/11000-1 PROPEL ALLOWABLE SLOPE ANGLE

1.4.1 CRANE ATTACHMENT INSTALLED : BOOM INSERT CONFIGURATION

CAUTION

In the area showing [-] mark, do not propel.
Machine may overturn.
Failure to observe this precaution may result in serious injuries or loss of life.

If the machine has to propel by some reason, observe the following points.

- Do not propel with a load lifted.
- Propel with low speed and gently.
- Propel on the flat and firm ground.
- Ensure to check the ground condition and propel on the slope angle smaller than shown in the chart.
- Propel straight against slope.
- Provide the gentle slope at the beginning and end positions of slope.

Propel upward downward on slope

(θ : allowable angle)

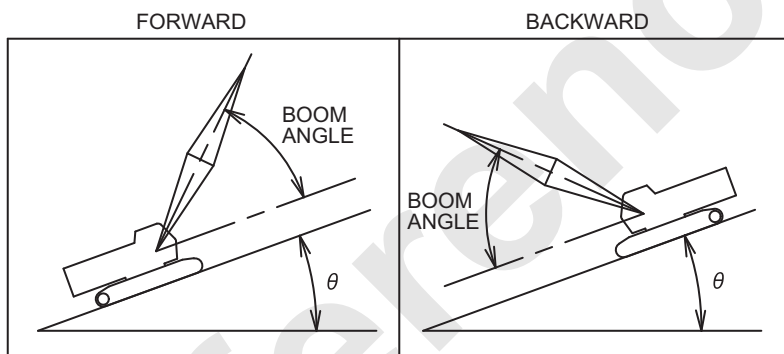

1. 10000-1/11000-1 CRANE PROPEL ALLOWABLE SLOPE ANGLE

(1) Without aux. sheave

(Unit : Degree)

Boom length m (ft)	Forward			Backward		
	Boom angle			Boom angle		
	35	40	50	40	50	60
12.2 (40)	5	5	4	8	8	8
15.2 (50)	7	6	5	8	8	8
18.3 (60)	8	8	6	8	8	8
21.3 (70)	8	8	6	8	8	8
24.4 (80)	8	8	7	8	8	8
27.4 (90)	8	8	8	8	8	8
30.5 (100)	8	8	8	8	8	8
33.5 (110)	8	8	8	8	8	8
36.6 (120)	8	8	8	8	8	8
39.6 (130)	8	8	8	8	8	8
42.7 (140)	8	8	8	8	8	8
45.7 (150)	8	8	8	8	8	8
48.8 (160)	8	8	8	7	8	8
51.8 (170)	8	8	8	5	6	8
54.9 (180)	8	8	8	3	4	6
57.9 (190)	8	8	8	1	2	5
61.0 (200)	8	8	8	-	1	3

(2) With aux. sheave

(Unit : Degree)

Boom length m (ft)	Forward			Backward		
	Boom angle			Boom angle		
	35	40	50	40	50	60
12.2 (40)	5	5	4	8	8	8
15.2 (50)	7	6	5	8	8	8
18.3 (60)	8	8	6	8	8	8
21.3 (70)	8	8	6	8	8	8
24.4 (80)	8	8	7	8	8	8
27.4 (90)	8	8	8	8	8	8
30.5 (100)	8	8	8	8	8	8
33.5 (110)	8	8	8	8	8	8
36.6 (120)	8	8	8	8	8	8
39.6 (130)	8	8	8	8	8	8
42.7 (140)	8	8	8	8	8	8
45.7 (150)	8	8	8	8	8	8
48.8 (160)	8	8	8	7	8	8
51.8 (170)	8	8	8	5	6	8
54.9 (180)	8	8	8	3	4	6
57.9 (190)	8	8	8	1	2	5

1. REFERENCE MATERIALS

2. 10000-1/11000-1 FIXED JIB PROPEL ALLOWABLE SLOPE ANGLE

(Unit : Degree)

Jib length m (ft)	9.1 (30)					
Offset angle	10					
Configuration	Forward			Backward		
Boom length m (ft)	Boom angle			Boom angle		
	35	40	50	40	50	60
24.4 (80)	8	8	8	8	8	8
27.4 (90)	8	8	8	8	8	8
30.5 (100)	8	8	8	8	8	8
33.5 (110)	8	8	8	8	8	8
36.6 (120)	8	8	8	8	8	8
39.6 (130)	8	8	8	8	8	8
42.7 (140)	8	8	8	8	8	8
45.7 (150)	8	8	8	8	8	8
48.8 (160)	8	8	8	8	8	8
51.8 (170)	8	8	8	8	8	8
54.9 (180)	8	8	8	6	8	8
57.9 (190)	8	8	8	2	6	8

(Unit : Degree)

Jib length m (ft)	9.1 (30)					
Offset angle	30					
Configuration	Forward			Backward		
Boom length m (ft)	Boom angle			Boom angle		
	35	40	50	40	50	60
24.4 (80)	8	8	8	8	8	8
27.4 (90)	8	8	8	8	8	8
30.5 (100)	8	8	8	8	8	8
33.5 (110)	8	8	8	8	8	8
36.6 (120)	8	8	8	8	8	8
39.6 (130)	8	8	8	8	8	8
42.7 (140)	8	8	8	8	8	8
45.7 (150)	8	8	8	8	8	8
48.8 (160)	8	8	8	8	8	8
51.8 (170)	8	8	8	8	8	8
54.9 (180)	8	8	8	7	8	8
57.9 (190)	8	8	8	2	6	8

(Unit : Degree)

Jib length m (ft)	12.2 (40)					
Offset angle	10					
Configuration	Forward			Backward		
Boom length m (ft)	Boom angle			Boom angle		
	35	40	50	40	50	60
24.4 (80)	8	8	8	8	8	8
27.4 (90)	8	8	8	8	8	8
30.5 (100)	8	8	8	8	8	8
33.5 (110)	8	8	8	8	8	8
36.6 (120)	8	8	8	8	8	8
39.6 (130)	8	8	8	8	8	8
42.7 (140)	8	8	8	8	8	8
45.7 (150)	8	8	8	8	8	8
48.8 (160)	8	8	8	8	8	8
51.8 (170)	8	8	8	8	8	8
54.9 (180)	8	8	8	4	8	8
57.9 (190)	8	8	8	-	4	8

(Unit : Degree)

Jib length m (ft)	12.2 (40)					
Offset angle	30					
Configuration	Forward			Backward		
Boom length m (ft)	Boom angle			Boom angle		
	35	40	50	40	50	60
24.4 (80)	8	8	8	8	8	8
27.4 (90)	8	8	8	8	8	8
30.5 (100)	8	8	8	8	8	8
33.5 (110)	8	8	8	8	8	8
36.6 (120)	8	8	8	8	8	8
39.6 (130)	8	8	8	8	8	8
42.7 (140)	8	8	8	8	8	8
45.7 (150)	8	8	8	8	8	8
48.8 (160)	8	8	8	8	8	8
51.8 (170)	8	8	8	8	8	8
54.9 (180)	8	8	8	4	8	8
57.9 (190)	8	8	8	-	4	8

1. REFERENCE MATERIALS

(Unit : Degree)

Jib length m (ft)	15.2 (50)					
Offset angle	10					
Configuration	Forward			Backward		
Boom length m (ft)	Boom angle			Boom angle		
	35	40	50	40	50	60
24.4 (80)	8	8	8	8	8	8
27.4 (90)	8	8	8	8	8	8
30.5 (100)	8	8	8	8	8	8
33.5 (110)	8	8	8	8	8	8
36.6 (120)	8	8	8	8	8	8
39.6 (130)	8	8	8	8	8	8
42.7 (140)	8	8	8	8	8	8
45.7 (150)	8	8	8	8	8	8
48.8 (160)	8	8	8	8	8	8
51.8 (170)	8	8	8	7	8	8
54.9 (180)	8	8	8	2	6	8
57.9 (190)	8	8	8	-	2	7

(Unit : Degree)

Jib length m (ft)	15.2 (50)					
Offset angle	30					
Configuration	Forward			Backward		
Boom length m (ft)	Boom angle			Boom angle		
	35	40	50	40	50	60
24.4 (80)	8	8	8	8	8	8
27.4 (90)	8	8	8	8	8	8
30.5 (100)	8	8	8	8	8	8
33.5 (110)	8	8	8	8	8	8
36.6 (120)	8	8	8	8	8	8
39.6 (130)	8	8	8	8	8	8
42.7 (140)	8	8	8	8	8	8
45.7 (150)	8	8	8	8	8	8
48.8 (160)	8	8	8	8	8	8
51.8 (170)	8	8	8	7	8	8
54.9 (180)	8	8	8	2	6	8
57.9 (190)	8	8	8	-	2	7

(Unit : Degree)

Jib length m (ft)	18.3 (60)					
Offset angle	10					
Configuration	Forward			Backward		
Boom length m (ft)	Boom angle			Boom angle		
	35	40	50	40	50	60
24.4 (80)	8	8	8	8	8	8
27.4 (90)	8	8	8	8	8	8
30.5 (100)	8	8	8	8	8	8
33.5 (110)	8	8	8	8	8	8
36.6 (120)	8	8	8	8	8	8
39.6 (130)	8	8	8	8	8	8
42.7 (140)	8	8	8	8	8	8
45.7 (150)	8	8	8	8	8	8
48.8 (160)	8	8	8	8	8	8
51.8 (170)	8	8	8	5	8	8
54.9 (180)	8	8	8	-	4	8
57.9 (190)	8	8	8	-	1	6

(Unit : Degree)

Jib length m (ft)	18.3 (60)					
Offset angle	30					
Configuration	Forward			Backward		
Boom length m (ft)	Boom angle			Boom angle		
	35	40	50	40	50	60
24.4 (80)	8	8	8	8	8	8
27.4 (90)	8	8	8	8	8	8
30.5 (100)	8	8	8	8	8	8
33.5 (110)	8	8	8	8	8	8
36.6 (120)	8	8	8	8	8	8
39.6 (130)	8	8	8	8	8	8
42.7 (140)	8	8	8	8	8	8
45.7 (150)	8	8	8	8	8	8
48.8 (160)	8	8	8	8	8	8
51.8 (170)	8	8	8	5	8	8
54.9 (180)	8	8	8	-	4	8
57.9 (190)	8	8	8	-	1	5

1. REFERENCE MATERIALS

1.5 10000E-1 SPECIFICATION

1.5.1 CRANE OUTER DIMENSION

1. STANDARD COUNTERWEIGHT

UNIT : mm (ft - in)

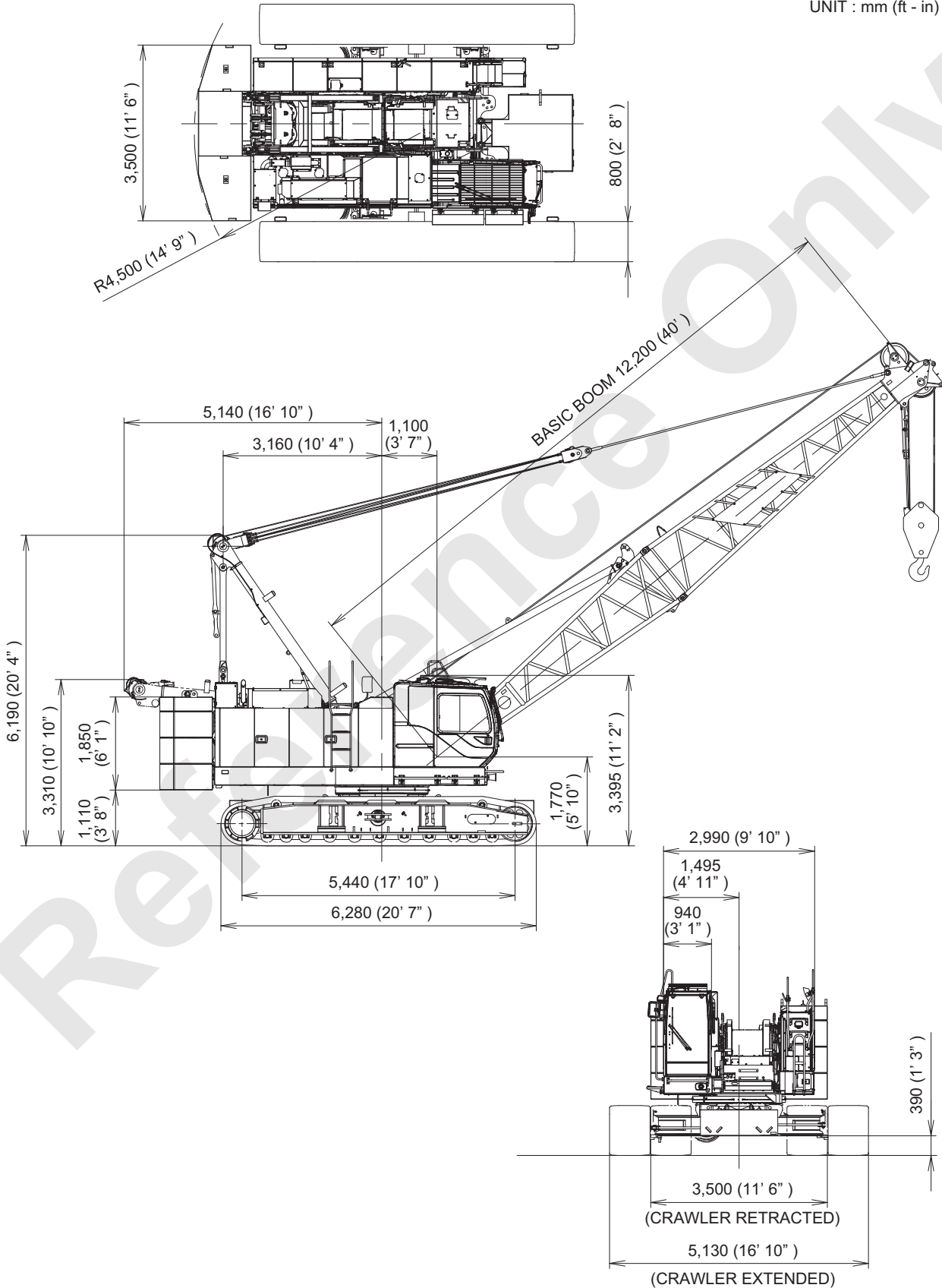

2. COUNTERWEIGHT WITH SELF-REMOVABLE DEVICE (OPTION)

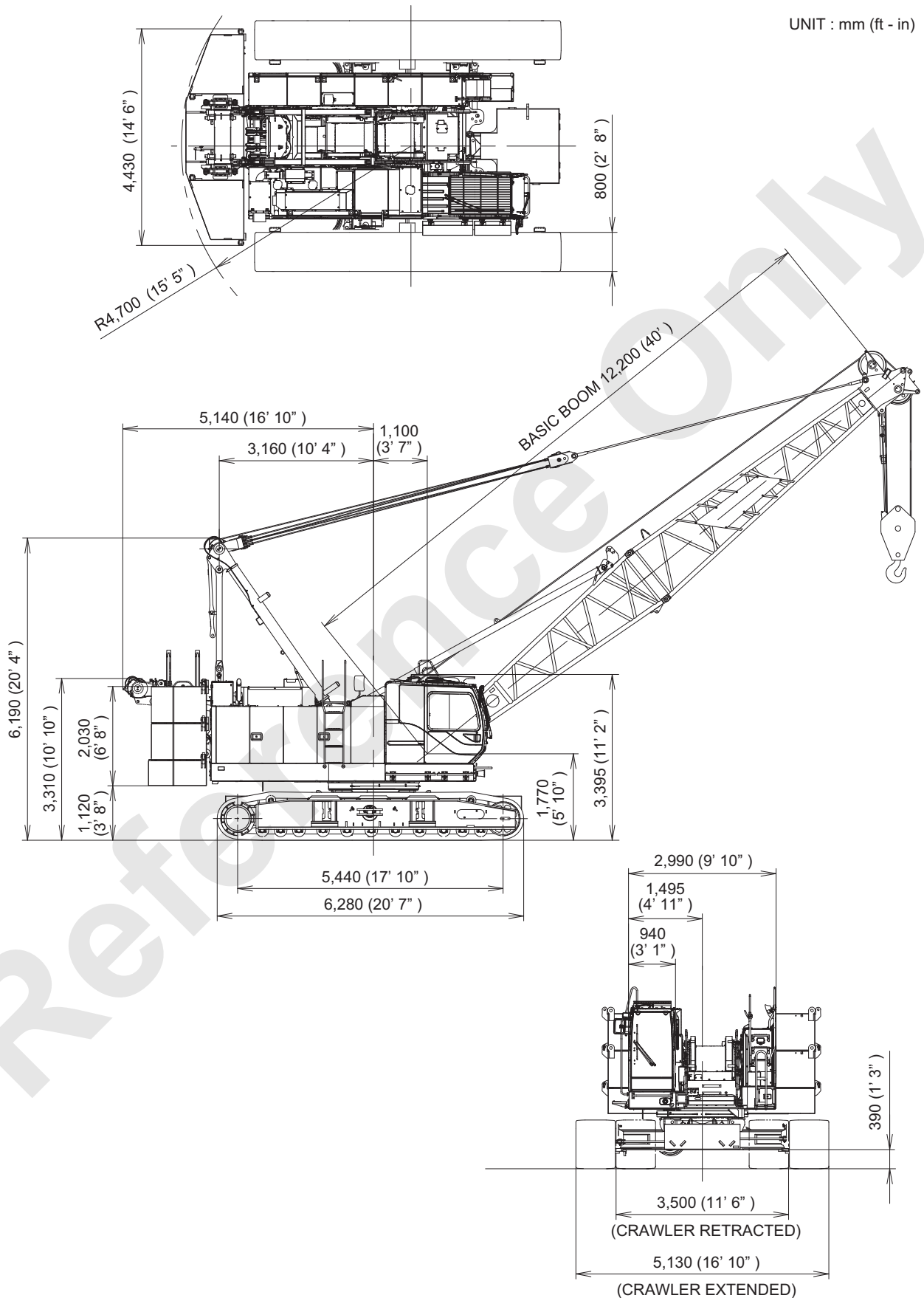

1. REFERENCE MATERIALS

1.5.2 CRANE SPECIFICATION, PERFORMANCE

Type		Full swing, crawler type		
Max. rated load × work radius		90.0 t × 3.9 m (198,400 lbs × 12.8 ft)		
Boom length	Basic boom	12.2 m (40 ft)		
	Maximum boom	61.0 m (200 ft)		
	Crane jib	9.1 m (30 ft) to 18.3 m (60 ft)		
	Maximum boom and jib	51.8 m (170 ft) Boom + 18.3 m (60 ft) Jib		
Work speed (wire rope)	Front / rear hoisting rope speed	120 to 3 m/min (390 to 10 ft/min)	Wire rope dia.	26 mm
	Front / rear lowering rope speed	120 to 3 m/min (390 to 10 ft/min)		
	Boom raising rope speed	70 to 2 m/min (230 to 6.6 ft/min)		16 mm
	Boom lowering rope speed	70 to 2 m/min (230 to 6.6 ft/min)		
	Third hoisting rope speed (Option)	120 to 3 m/min (390 to 10 ft/min)		22 mm
	Third lowering rope speed (Option)	120 to 3 m/min (390 to 10 ft/min)		
	Swing speed	4.0 min ⁻¹ (4.0 rpm)		
	Propel speed	1.7/1.1 km/h (1.1/0.72 mph)		
Gradability (tan θ)		40%		
Working weight (Basic boom + 90 t hook)		Approx. 90.0 t (198,500 lbs)		
Average ground pressure (Basic boom + 90 t hook)		101.5 kPa (14.7 psi)		
Engine	Engine name	Hino J08E-UV		
	Engine out put	213 kW/2,100 min ⁻¹ (286 HP/2,100 rpm)		

1. Each rope speed varies based on load.
2. Each rope speed is the value of the drum first layer's one.

OUTSIDE DIMENSIONS

Unit : mm (ft-in)

Overall width of cab	2,990 (9' 10")
Radius of rear end (counterweight)	4,500 (14' 9")
Center of rotation to rear end (Low gantry position)	5,140 (16' 10")
Center of rotation to boom foot pin (from center of rotation)	1,100 (3' 7")
Height from ground to boom foot pin	1,770 (5' 10")
Height to top of gantry (Working position)	6,190 (20' 4")
Height to top of gantry (Low gantry position)	3,310 (10' 10")
Counterweight ground clearance	1,110 (3' 8")
Overall length of crawlers	6,280 (20' 7")
Distance between centers of tumblers	5,440 (17' 10")
Overall width of crawlers (Extend/Retract)	5,130/3,500 (16' 10"/11' 6")
Width of crawler shoe	800 (2' 8")
Ground clearance of carbody	390 (1' 3")

1.5.3 CRANE WORKING RANGES

1. CRANE WORKING RANGES

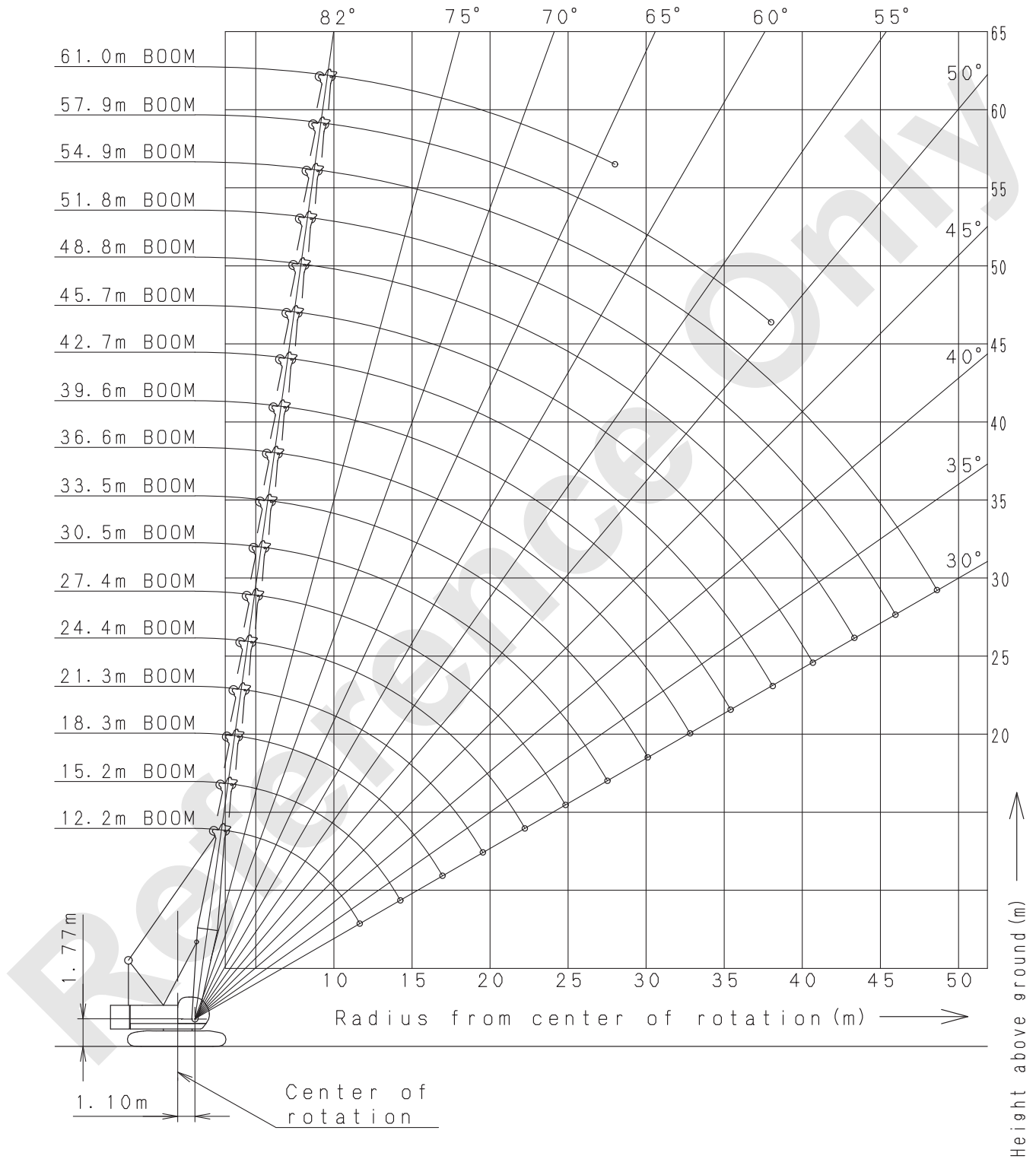

1. REFERENCE MATERIALS

2. JIB WORKING RANGE

(1) Offset angle 10 degrees

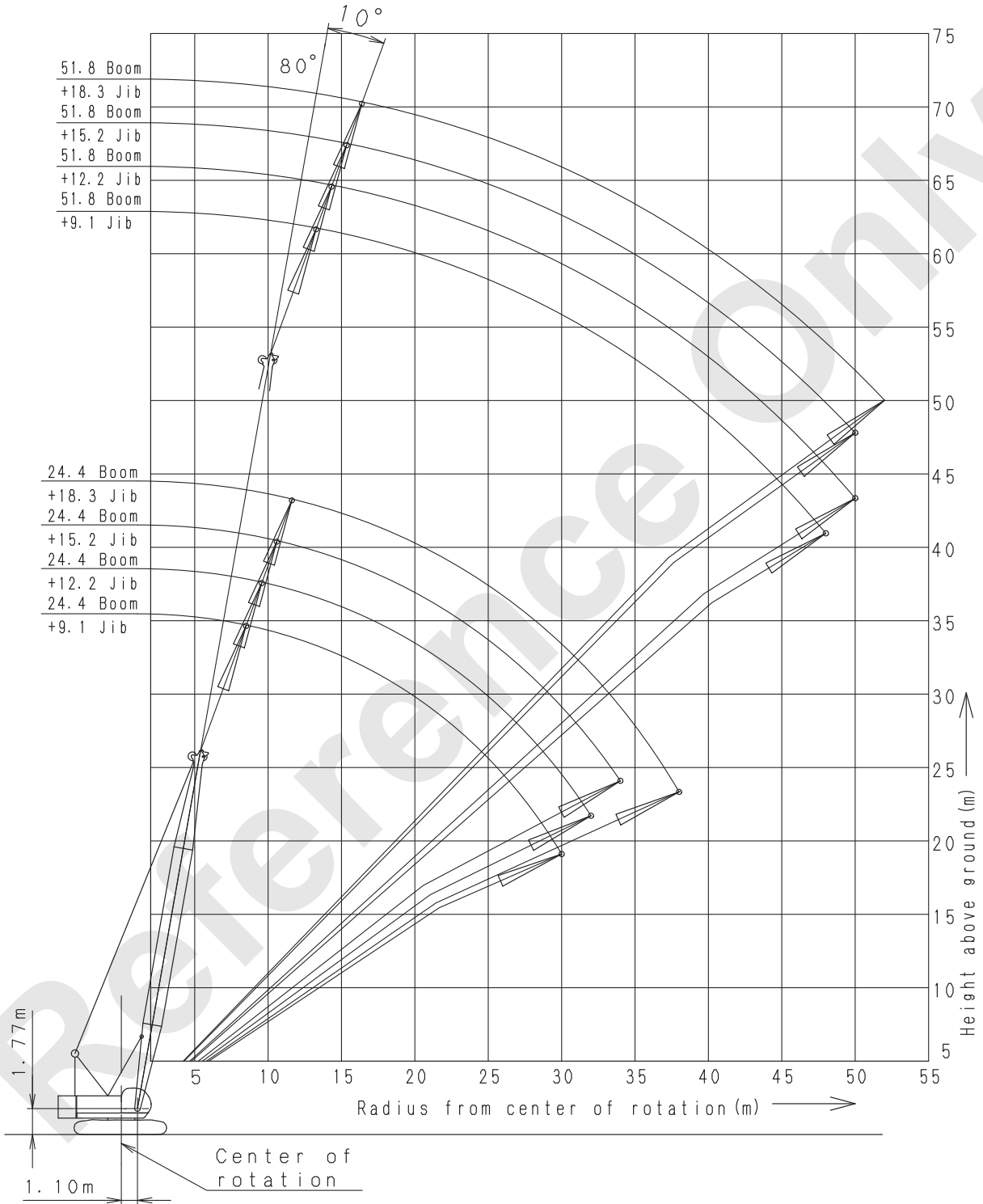

(2) Offset angle 30 degrees

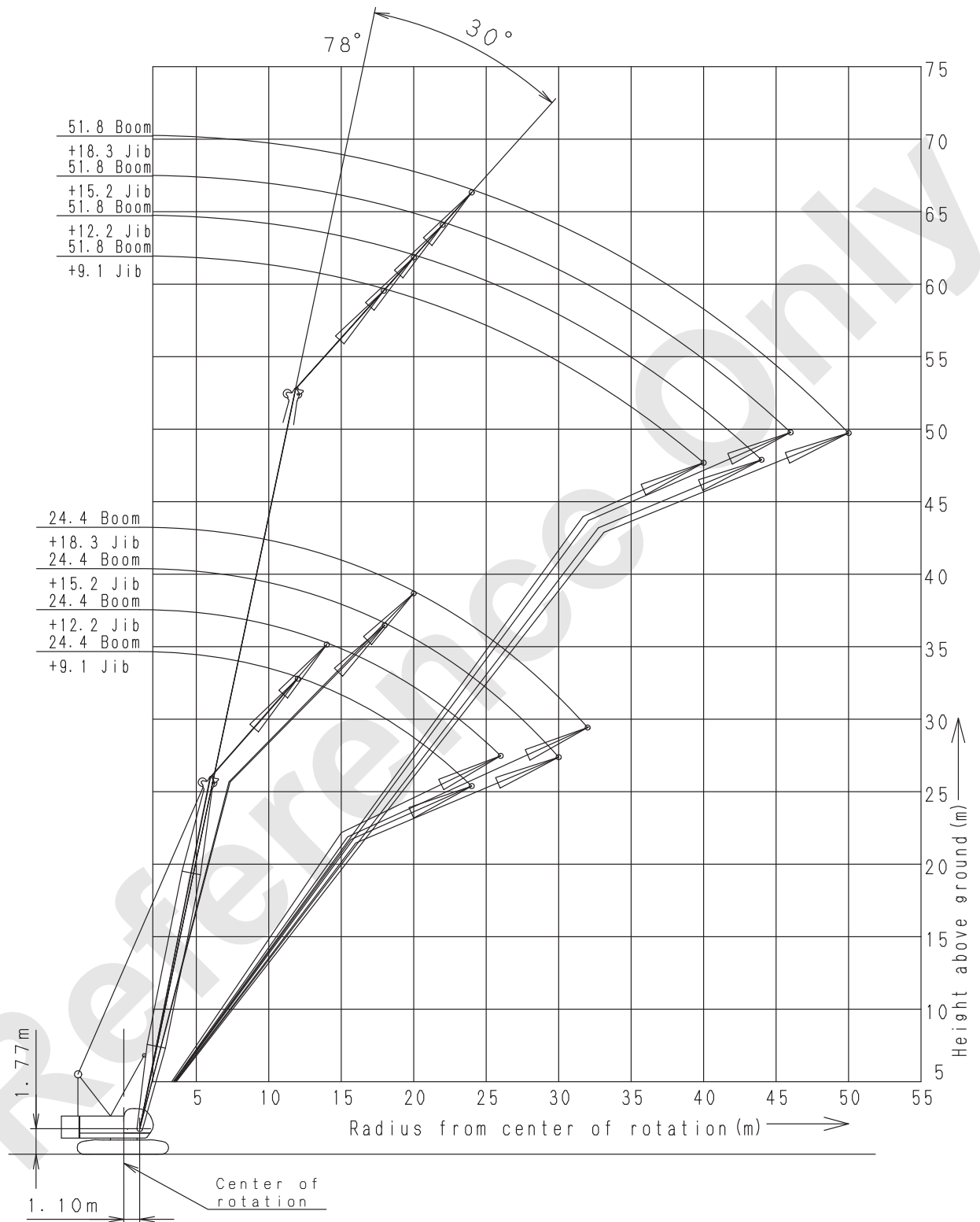

1. REFERENCE MATERIALS

1.6 10000E-1 DIMENSION, WEIGHT OF EACH COMPONENT

Dimension and weight of each component when disassembled is shown here.
Use this as reference value.

1.6.1 MAIN MACHINERY

Name	Dimension mm (ft-in)	Weight kg (lbs)
Base Machine • Boom base • Gantry • Crawler • Wire rope (Front / rear / boom hoist)		41,360 (91,182)
Base Machine • Gantry • Crawler • Wire rope (Front / rear / boom hoist)		39,300 (86,640)
Base Machine • Boom base • Gantry • Wire rope (Front / rear / boom hoist) • Without crawler • Without side steps		27,000 (59,524)
Base Machine • Gantry • Wire rope (Front / rear / boom hoist) • Without crawler • Without side steps		24,940 (54,982)
Crawler		7,180 (15,827)

*1 With the side step on cabin side : 3,170 (10' 5")
With the side steps on the both side : 3,340 (11')

1.6.2 COUNTERWEIGHT

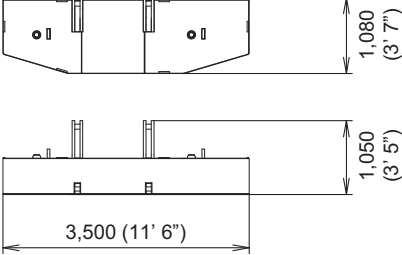
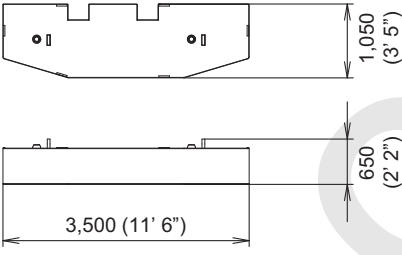
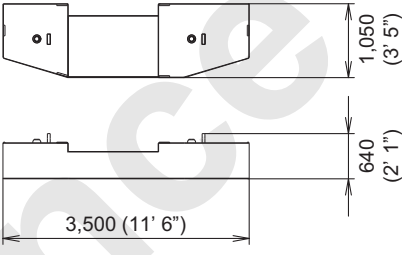
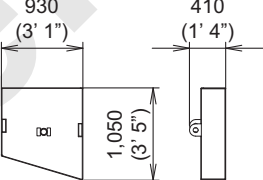
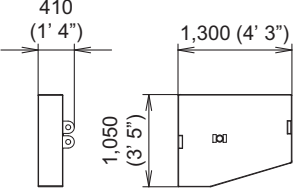
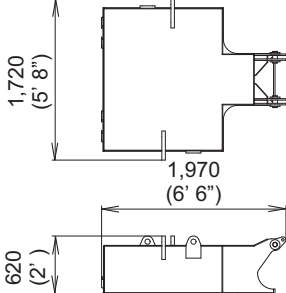
Name	Dimension mm (ft-in)	Weight kg (lbs)
Counterweight (1)		10,540 (22,237)
Counterweight (2)		9,930 (21,892)
Counterweight (3)		8,250 (18,188)
Counterweight (L) (4)		1,280 (2,822)
Counterweight (R) (5)		1,900 (4,189)
Carbody weight		7,200 (15,873)

1. REFERENCE MATERIALS

1.6.3 COUNTERWEIGHT WITH SELF-REMOVABLE DEVICE (OPTION)

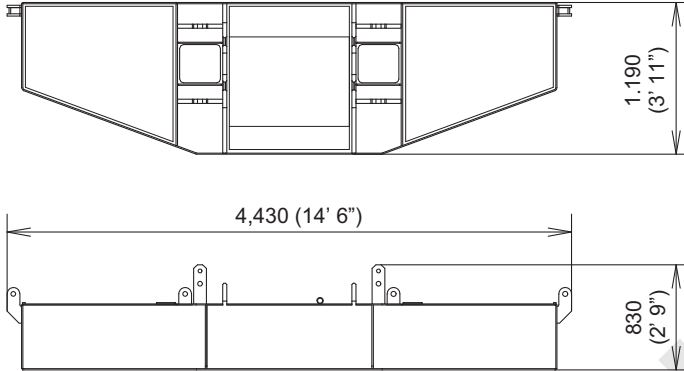
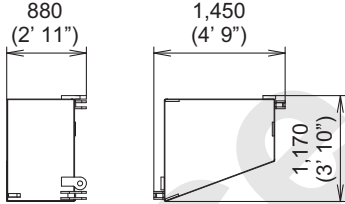
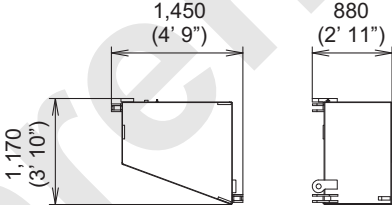
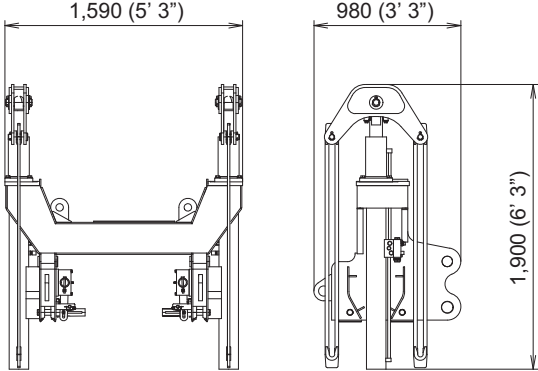
Name	Dimension mm (ft-in)	Weight kg (lbs)
Counterweight (1) (Option)		8,310 (18,300)
Counterweight (R) (3) (5) (Option)		5,750 / 1 piece (12,680)
Counterweight (L) (2) (4) (Option)		5,750 / 1 piece (12,680)
Self removal unit (Option)		870 (1,918)

1.6.4 ATTACHMENT

Name	Dimension mm (ft-in)	Weight kg (lbs)
Boom tip		1,220 (2,690)
Boom base		1,120 (2,470)
3.0m (10ft) Boom insert		300 (660)
6.1m (20ft) Boom insert		510 (1,125)
12.2m (40ft) insert Boom		950 (2,100)
12.2m (40ft) Boom insert (with lug)		1,220 (2,690)

1. REFERENCE MATERIALS

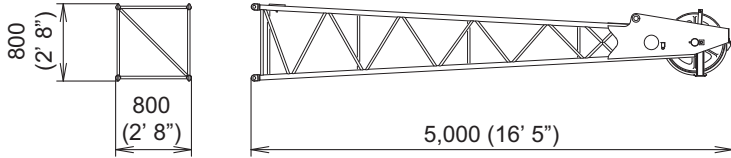
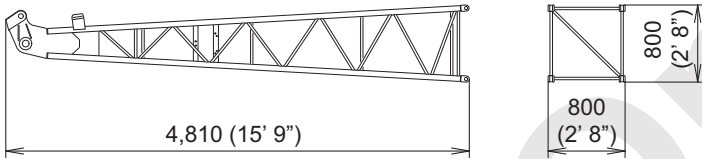
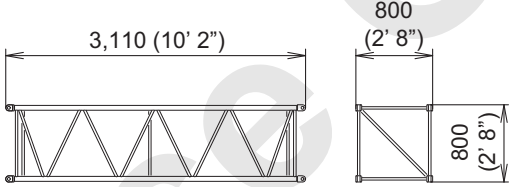
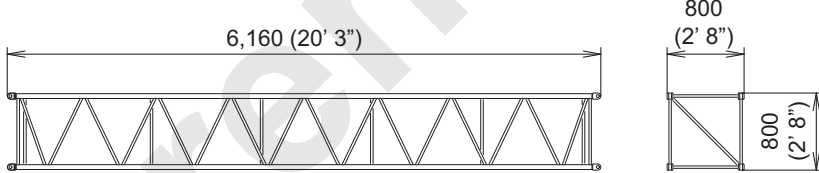
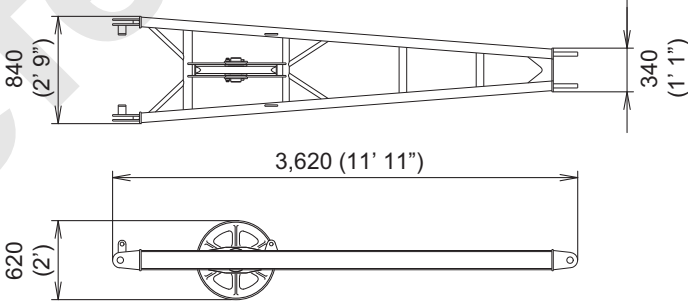
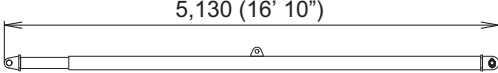
Name	Dimension mm (ft-in)	Weight kg (lbs)
Upper Jib		180 (400)
Lower Jib		200 (440)
3.0m (10ft) Jib insert		100 (220)
6.1m (20ft) Jib insert		180 (395)
strut		250 (550)
Crane backstop		270 (1set)

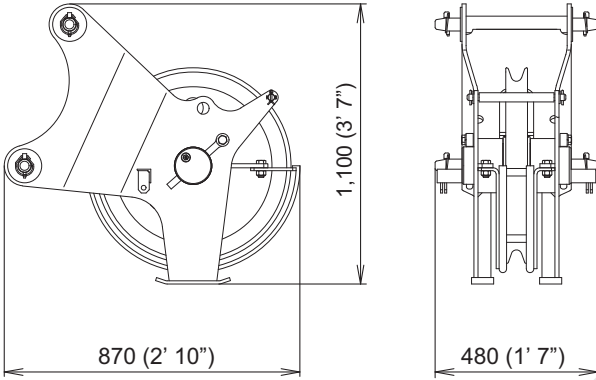
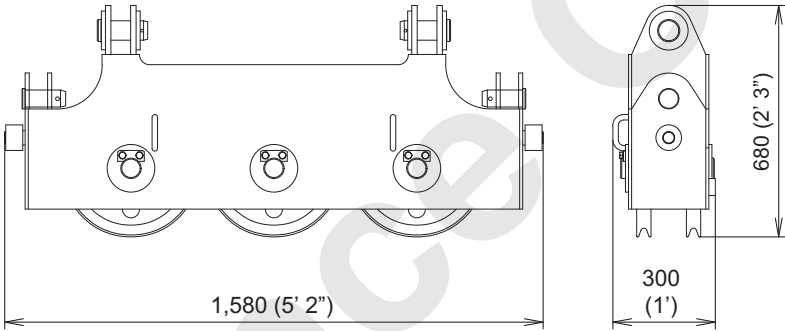
Name	Dimension mm (ft-in)	Weight kg (lbs)
Auxiliary sheave		195 (430)
Upper spreader		280 (620)

1. REFERENCE MATERIALS

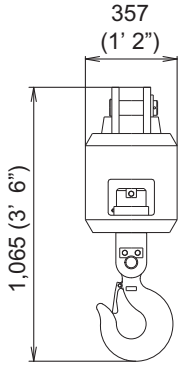
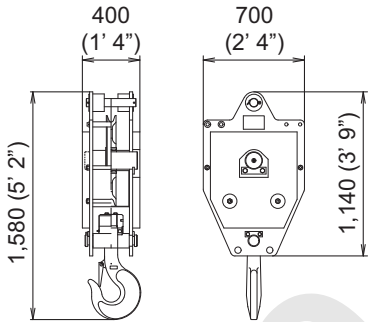
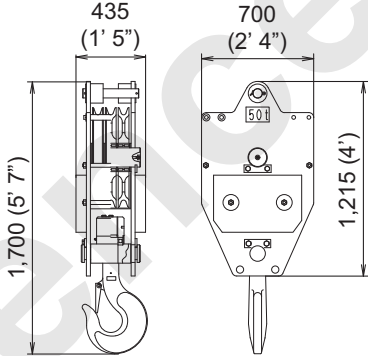
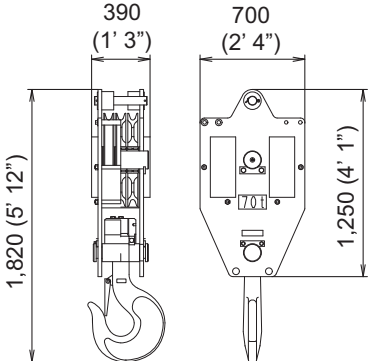
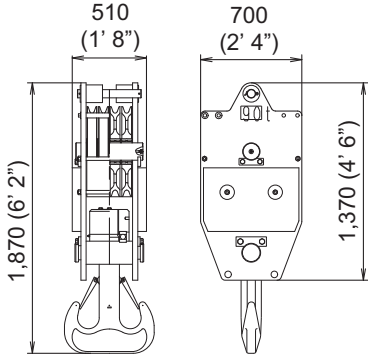
Name	Dimension mm (ft-in)	Weight kg (lbs)
Ball hook		300 (661)
35t Hook		700 (1,544)
50t Hook		850 (1,874)
70t Hook		900 (1,985)
90t Hook		1,300 (2,867)

1.7 10000E-1 SWING AND PROPEL STABILITY

1. Without carbody weight

Attachment	Counterweight ton (lbs)	All-round swing		Propelling on slope	
		Crawler extend	Crawler retract	Forward	Backward
Without attachment (Base machine only)	0 (Without)	○	○	○	○
	10.54 (23,237) (No.1)	○	×	△ (Slope:13 deg. or less)	○
	20.47 (45,129) (No.1 to No.2)	△ (No abrupt lever control)	×	×	△
	28.72 (63,317) (No.1 to No.3)	×	×	×	×
	31.9 (70,328) (No.1 to No.4)	×	×	×	×
With boom base (Boom angle : 10 degrees or less)	0 (Without)	○	○	○	○
	10.54 (23,237) (No.1)	○	△ (No abrupt lever control)	○	○
	20.47 (45,129) (No.1 to No.2)	○	×	×	○
	28.72 (63,317) (No.1 to No.3)	×	×	×	×
	31.9 (70,328) (No.1 to No.4)	×	×	×	×
With basic boom (Boom angle : 30 degrees or less)	0 (Without)	○	○	○	○
	10.54 (23,237) (No.1)	○	○	○	○
	20.47 (45,129) (No.1 to No.2)	○	×	△ (Slope:8 deg. or less)	○
	28.72 (63,317) (No.1 to No.3)	△ (No abrupt lever control)	×	×	△
	31.9 (70,328) (No.1 to No.4)	△ (No abrupt lever control)	×	×	△

○ : Able to be operated
 △ : Able to be operated with conditions
 × : Unable to be operated

- (1) The table above shows the values for operation on a firm ground.
 On a weak ground, operate with care after curing the ground.
- (2) As a principle, swinging on a trailer is prohibited.
- (3) Maximum slope angle is 21.8 degrees (40%).
 This may become lower depending on condition (ground, crane configuration).
- (4) Travelling forward means the case where the counterweight is at the lower slope and the traveling backward where it is at the upper slope.

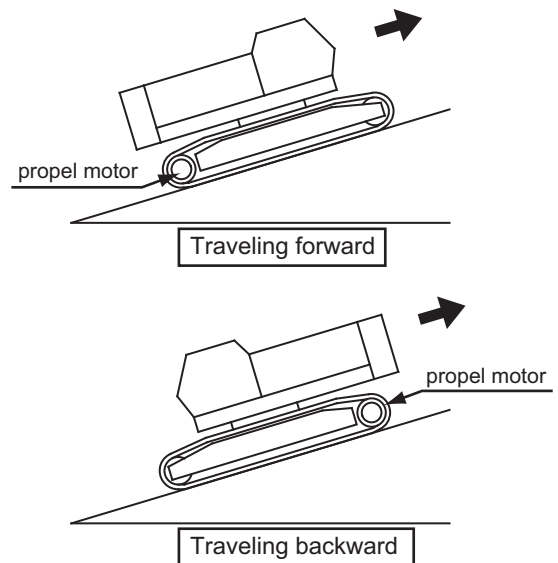

1. REFERENCE MATERIALS

2. With carbody weight

Attachment	Counterweight ton (lbs)	All-round swing		Propelling on slope	
		Crawler extend	Crawler retract	Forward	Backward
Without attachment (Base machine only)	0 (Without)	○	○	○	○
	10.54 (23,237) (No.1)	○	○	○	○
	20.47 (45,129) (No.1 to No.2)	○	×	△ (Slope:8 deg. or less)	○
	28.72 (63,317) (No.1 to No.3)	△(No abrupt lever control)	×	×	△
	31.9 (70,328) (No.1 to No.4)	△(No abrupt lever control)	×	×	△
With boom base (Boom angle : 10 degrees or less)	0 (Without)	○	○	○	○
	10.54 (23,237) (No.1)	○	○	○	○
	20.47 (45,129) (No.1 to No.2)	○	×	△ (Slope:12 deg. or less)	○
	28.72 (63,317) (No.1 to No.3)	○	×	×	○
	31.9 (70,328) (No.1 to No.4)	△(No abrupt lever control)	×	×	△
With basic boom (Boom angle : 30 degrees or less)	0 (Without)	○	○	○	○
	10.54 (23,237) (No.1)	○	○	○	○
	20.47 (45,129) (No.1 to No.2)	○	△(No abrupt lever control)	○	○
	28.72 (63,317) (No.1 to No.3)	○	×	△ (Slope:7 deg. or less)	○
	31.9 (70,328) (No.1 to No.4)	○	×	△ (Slope:3 deg. or less)	○

○ : Able to be operated
 △ : Able to be operated with conditions
 × : Unable to be operated

- (1) The table above shows the values for operation on a firm ground.
 On a weak ground, operate with care after curing the ground.
- (2) As a principle, swinging on a trailer is prohibited.
- (3) Maximum slope angle is 21.8 degrees (40%).
 This may become lower depending on condition (ground, crane configuration).
- (4) Travelling forward means the case where the counterweight is at the lower slope and the traveling backward where it is at the upper slope.

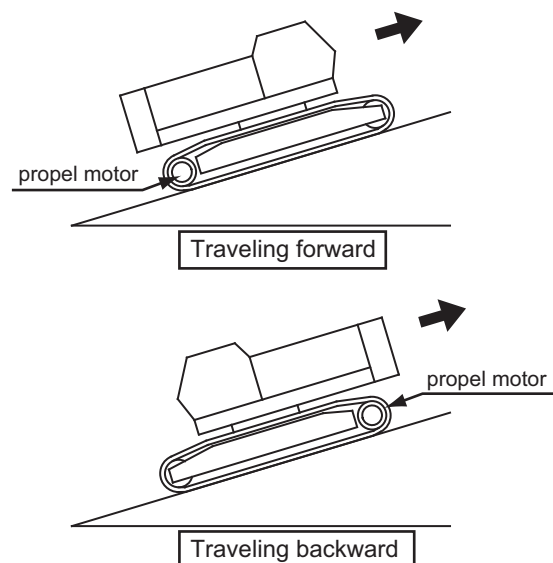

1.8 10000E-1 PROPEL ALLOWABLE SLOPE ANGLE

1.8.1 CRANE ATTACHMENT INSTALLED : BOOM INSERT CONFIGURATION

CAUTION

In the area showing [-] mark, do not propel.

Machine may overturn.

Failure to observe this precaution may result in serious injuries or loss of life.

If the machine has to propel by some reason, observe the following points.

- Do not propel with a load lifted.
- Propel with low speed and gently.
- Propel on the flat and firm ground.
- Ensure to check the ground condition and propel on the slope angle smaller than shown in the chart.
- Propel straight against slope.
- Provide the gentle slope at the beginning and end positions of slope.

Propel upward downward on slope

(θ : allowable angle)

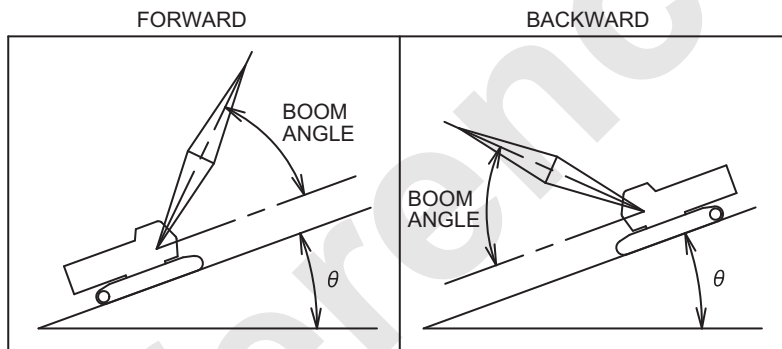

1. REFERENCE MATERIALS

1. 10000E-1 CRANE PROPEL ALLOWABLE SLOPE ANGLE

(1) Without aux. sheave

(Unit : Degree)

Boom length m (ft)	Forward			Backward		
	Boom angle			Boom angle		
	35	40	50	40	50	60
12.2 (40)	5	5	4	8	8	8
15.2 (50)	7	6	5	8	8	8
18.3 (60)	8	8	6	8	8	8
21.3 (70)	8	8	7	8	8	8
24.4 (80)	8	8	8	8	8	8
27.4 (90)	8	8	8	8	8	8
30.5 (100)	8	8	8	8	8	8
33.5 (110)	8	8	8	8	8	8
36.6 (120)	8	8	8	8	8	8
39.6 (130)	8	8	8	8	8	8
42.7 (140)	8	8	8	8	8	8
45.7 (150)	8	8	8	7	8	8
48.8 (160)	8	8	8	7	8	8
51.8 (170)	8	8	8	4	6	7
54.9 (180)	8	8	8	2	4	6
57.9 (190)	8	8	8	-	2	4
61.0 (200)	8	8	8	-	-	3

(2) With aux. sheave

(Unit : Degree)

Boom length m (ft)	Forward			Backward		
	Boom angle			Boom angle		
	35	40	50	40	50	60
12.2 (40)	5	5	4	8	8	8
15.2 (50)	7	6	5	8	8	8
18.3 (60)	8	8	6	8	8	8
21.3 (70)	8	8	7	8	8	8
24.4 (80)	8	8	8	8	8	8
27.4 (90)	8	8	8	8	8	8
30.5 (100)	8	8	8	8	8	8
33.5 (110)	8	8	8	8	8	8
36.6 (120)	8	8	8	8	8	8
39.6 (130)	8	8	8	8	8	8
42.7 (140)	8	8	8	8	8	8
45.7 (150)	8	8	8	7	8	8
48.8 (160)	8	8	8	7	8	8
51.8 (170)	8	8	8	4	6	7
54.9 (180)	8	8	8	2	4	6
57.9 (190)	8	8	8	-	2	4

2. 10000E-1 FIXED JIB PROPEL ALLOWABLE SLOPE ANGLE

(Unit : Degree)

Jib length m (ft)	9.1 (30)					
Offset angle	10					
Configuration	Forward			Backward		
Boom length m (ft)	Boom angle			Boom angle		
	35	40	50	40	50	60
24.4 (80)	8	8	8	8	8	8
27.4 (90)	8	8	8	8	8	8
30.5 (100)	8	8	8	8	8	8
33.5 (110)	8	8	8	8	8	8
36.6 (120)	8	8	8	8	8	8
39.6 (130)	8	8	8	8	8	8
42.7 (140)	8	8	8	8	8	8
45.7 (150)	8	8	8	8	8	8
48.8 (160)	8	8	8	7	8	8
51.8 (170)	8	8	8	5	6	8
54.9 (180)	8	8	8	3	4	6
57.9 (190)	8	8	8	1	2	5

(Unit : Degree)

Jib length m (ft)	9.1 (30)					
Offset angle	30					
Configuration	Forward			Backward		
Boom length m (ft)	Boom angle			Boom angle		
	35	40	50	40	50	60
24.4 (80)	8	8	8	8	8	8
27.4 (90)	8	8	8	8	8	8
30.5 (100)	8	8	8	8	8	8
33.5 (110)	8	8	8	8	8	8
36.6 (120)	8	8	8	8	8	8
39.6 (130)	8	8	8	8	8	8
42.7 (140)	8	8	8	8	8	8
45.7 (150)	8	8	8	8	8	8
48.8 (160)	8	8	8	7	8	8
51.8 (170)	8	8	8	5	6	8
54.9 (180)	8	8	8	3	4	6
57.9 (190)	8	8	8	1	2	5

1. REFERENCE MATERIALS

(Unit : Degree)

Jib length m (ft)	12.2 (40)					
Offset angle	10					
Configuration	Forward			Backward		
Boom length m (ft)	Boom angle			Boom angle		
	35	40	50	40	50	60
24.4 (80)	8	8	8	8	8	8
27.4 (90)	8	8	8	8	8	8
30.5 (100)	8	8	8	8	8	8
33.5 (110)	8	8	8	8	8	8
36.6 (120)	8	8	8	8	8	8
39.6 (130)	8	8	8	8	8	8
42.7 (140)	8	8	8	8	8	8
45.7 (150)	8	8	8	8	8	8
48.8 (160)	8	8	8	6	7	8
51.8 (170)	8	8	8	4	5	7
54.9 (180)	8	8	8	2	3	5
57.9 (190)	8	8	8	-	1	4

(Unit : Degree)

Jib length m (ft)	12.2 (40)					
Offset angle	30					
Configuration	Forward			Backward		
Boom length m (ft)	Boom angle			Boom angle		
	35	40	50	40	50	60
24.4 (80)	8	8	8	8	8	8
27.4 (90)	8	8	8	8	8	8
30.5 (100)	8	8	8	8	8	8
33.5 (110)	8	8	8	8	8	8
36.6 (120)	8	8	8	8	8	8
39.6 (130)	8	8	8	8	8	8
42.7 (140)	8	8	8	8	8	8
45.7 (150)	8	8	8	8	8	8
48.8 (160)	8	8	8	6	7	8
51.8 (170)	8	8	8	4	5	7
54.9 (180)	8	8	8	2	3	5
57.9 (190)	8	8	8	-	1	4

(Unit : Degree)

Jib length m (ft)	15.2 (50)					
Offset angle	10					
Configuration	Forward			Backward		
Boom length m (ft)	Boom angle			Boom angle		
	35	40	50	40	50	60
24.4 (80)	8	8	8	8	8	8
27.4 (90)	8	8	8	8	8	8
30.5 (100)	8	8	8	8	8	8
33.5 (110)	8	8	8	8	8	8
36.6 (120)	8	8	8	8	8	8
39.6 (130)	8	8	8	8	8	8
42.7 (140)	8	8	8	8	8	8
45.7 (150)	8	8	8	7	8	8
48.8 (160)	8	8	8	5	6	8
51.8 (170)	8	8	8	3	4	6
54.9 (180)	8	8	8	1	2	4
57.9 (190)	8	8	8	-	1	3

(Unit : Degree)

Jib length m (ft)	15.2 (50)					
Offset angle	30					
Configuration	Forward			Backward		
Boom length m (ft)	Boom angle			Boom angle		
	35	40	50	40	50	60
24.4 (80)	8	8	8	8	8	8
27.4 (90)	8	8	8	8	8	8
30.5 (100)	8	8	8	8	8	8
33.5 (110)	8	8	8	8	8	8
36.6 (120)	8	8	8	8	8	8
39.6 (130)	8	8	8	8	8	8
42.7 (140)	8	8	8	8	8	8
45.7 (150)	8	8	8	7	8	8
48.8 (160)	8	8	8	5	6	8
51.8 (170)	8	8	8	3	4	6
54.9 (180)	8	8	8	1	2	4
57.9 (190)	8	8	8	-	1	3

1. REFERENCE MATERIALS

(Unit : Degree)

Jib length m (ft)	18.3 (60)					
Offset angle	10					
Configuration	Forward			Backward		
Boom length m (ft)	Boom angle			Boom angle		
	35	40	50	40	50	60
24.4 (80)	8	8	8	8	8	8
27.4 (90)	8	8	8	8	8	8
30.5 (100)	8	8	8	8	8	8
33.5 (110)	8	8	8	8	8	8
36.6 (120)	8	8	8	8	8	8
39.6 (130)	8	8	8	8	8	8
42.7 (140)	8	8	8	8	8	8
45.7 (150)	8	8	8	6	7	8
48.8 (160)	8	8	8	4	5	7
51.8 (170)	8	8	8	2	3	5
54.9 (180)	8	8	8	-	1	4
57.9 (190)	8	8	8	-	-	2

(Unit : Degree)

Jib length m (ft)	18.3 (60)					
Offset angle	30					
Configuration	Forward			Backward		
Boom length m (ft)	Boom angle			Boom angle		
	35	40	50	40	50	60
24.4 (80)	8	8	8	8	8	8
27.4 (90)	8	8	8	8	8	8
30.5 (100)	8	8	8	8	8	8
33.5 (110)	8	8	8	8	8	8
36.6 (120)	8	8	8	8	8	8
39.6 (130)	8	8	8	8	8	8
42.7 (140)	8	8	8	8	8	8
45.7 (150)	8	8	8	6	7	8
48.8 (160)	8	8	8	4	5	7
51.8 (170)	8	8	8	2	3	5
54.9 (180)	8	8	8	-	1	4
57.9 (190)	8	8	8	-	-	2

1.9 ENGINE MAIN SPECIFICATION

Engine	10000-1/11000-1 : Hino Model J08E-UV diesel engine (complying with the Interim Tier4 & Stage IIIB Emission Regulations) 10000E-1 : Hino Model J08E-UV diesel engine (complying with the Interim Tier4 & Stage IIIB Emission Regulations) 10000-1/11000-1 : Hino Model J08E-VM diesel engine
Configuration of engine	4 cycle, water cooled, vertical in-line 6, direct injection, turbo-charged, intercooled
Total piston displacement	7.684 Litter
Rated output	213 kW / 2,100 min-1
Max. torque	1,017 N ·m / 1,600 min-1
Specific fuel consumption	212 g / kWh / 2,100 min-1
Dry engine weight	Approx. 735 kg

FUEL CONSUMPTION (REF)

Hourly fuel consumption at engine rated output when crawler crane is working.

Fuel consumption (L/hr)	At rated output	At crane work (*1)	At foundation work (*2)
10000-1/11000-1 : J08E-UV 10000E-1 : J08E-UV 10000-1/11000-1 : J08E-VM	54.1	16.2	27.0

(*1) Is calculated with assumption that average load ratio is 30%
at crane work and fuel consumption is proportional to load.

(*2) Is calculated with assumption that average load ratio is 60%
at foundation work and fuel consumption is proportional to load.

Since fuel consumption may vary depending on work content, operators technique and waiting time at actual work, the above figure is for reference only.

Fuel consumption based on energy saving function including G engine mode , G winch mode or auto-idling stop are not Included.

1. REFERENCE MATERIALS

ENGINE PERFORMANCE CURVE

This indicates performance curve of single unit of engine.

This does not include performance lowering based on work load.

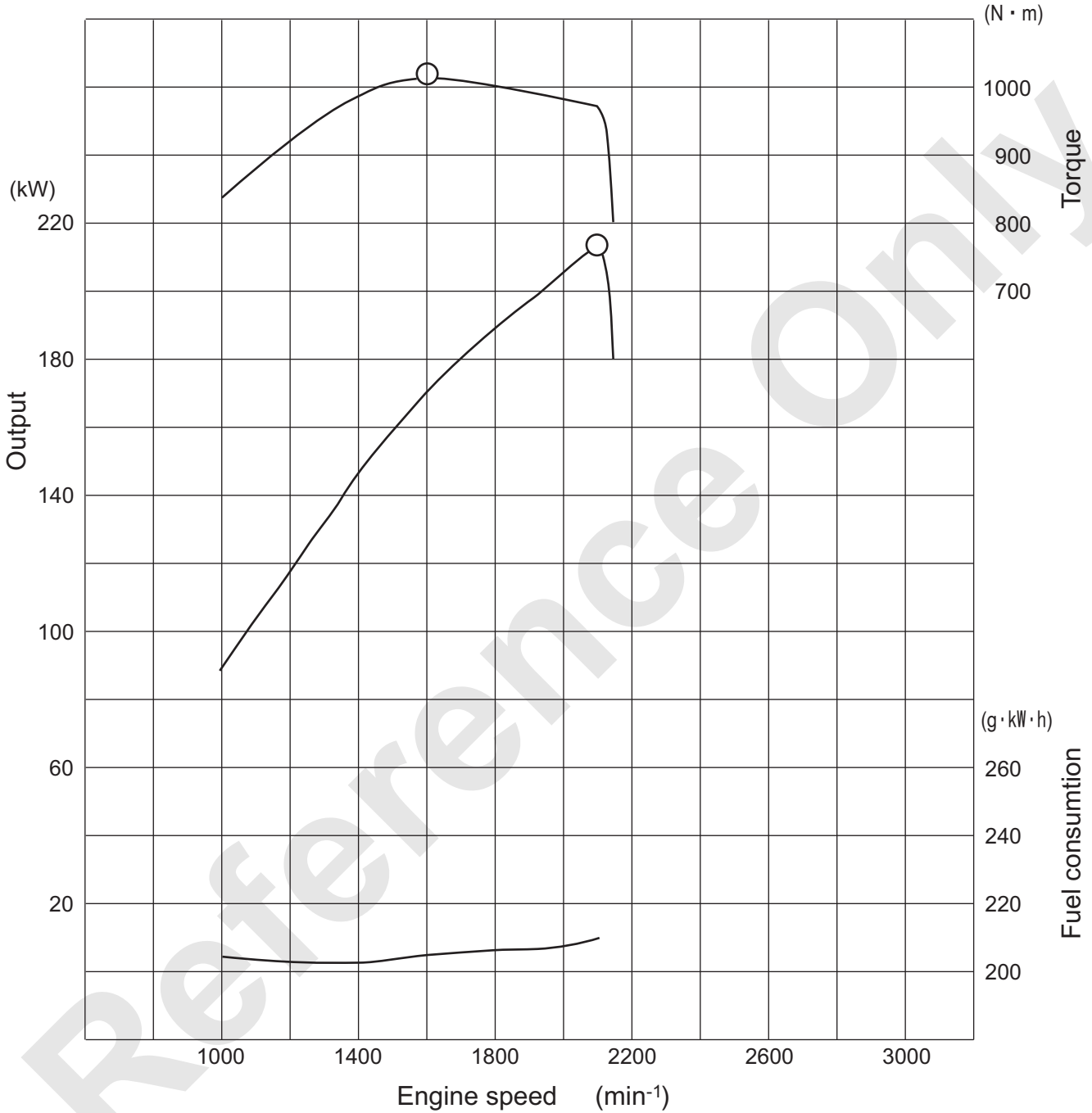

2. MAINTENANCE STANDARDS TEST PROCEDURES

Reference Only

Reference Only

2.1 MAINTENANCE STANDARD

2.1.1 PIN, BUSHING, SPRING, LINING AND SHEAVE

1. Pin, Bushing

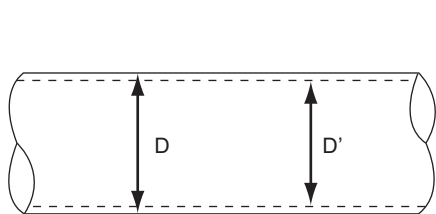

PIN

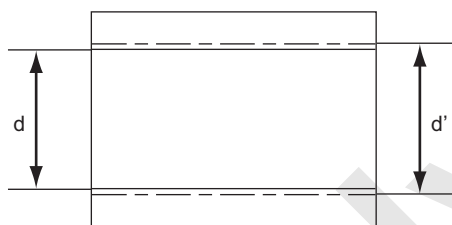

Bushing

Unit : mm (inch)

Name	Location	Item	Std. dimension D	Usable limit D'	Remedy	See figure
Pawl	Front/rear drum	3	44.0 (1.732)	43.84 (1.726)	Replace	Fig.2-1 (P.2-6)
	Boom drum	2	45.0 (1.772)	44.82 (1.765)		Fig.2-4 (P.2-7)
Pin	Brake pedal	7	38.1 (1.5)	37.92 (1.493)	Replace	Fig.2-5 (P.2-8)
		8, 9	13.0 (0.512)	12.85 (0.506)		
		10	13.0 (0.512)	12.85 (0.506)		
		11, 12	10.0 (0.394)	9.96 (0.392)		
Boom foot	2	114.7 (4.516)	114.04 (4.490)	Replace	Fig.2-6 (P.2-8)	

Unit : mm (inch)

Name	Location	Item	Std. dimension d	Usable limit d'	Remedy	See figure
Bushing	Pawl (Front/rear)	3	44.0 (1.732)	44.26 (1.743)	Replace	Fig.2-1 (P.2-6)
	Pawl (Boom)	3	45.0 (1.772)	45.27 (1.782)	Replace	Fig.2-4 (P.2-7)
	Boom foot	3	115.0 (4.528)	115.4 (4.541)	Replace	Fig.2-6 (P.2-8)

2. MAINTENANCE STANDARDS TEST PROCEDURES

2. Spring

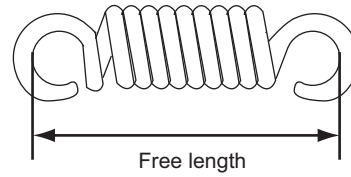
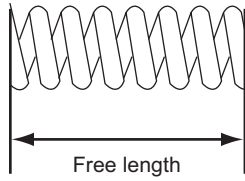

Unit : mm (inch)

Location	Item	Std. free length	Usable limit of free length	Remedy	See figure
Front/rear drum pawl	5	72 (2.835) (Compression)	68.4 (2.693)	Replace	Fig.2-1 (P.2-6)
Boom drum pawl	5	72 (2.835) (Compression)	68.4 (2.693)		Fig.2-3 (P.2-7)
Brake pedal	15	61.5 (2.421) (Tension)	63.9 (2.516)		Fig.2-5 (P.2-8)

3. Sheave

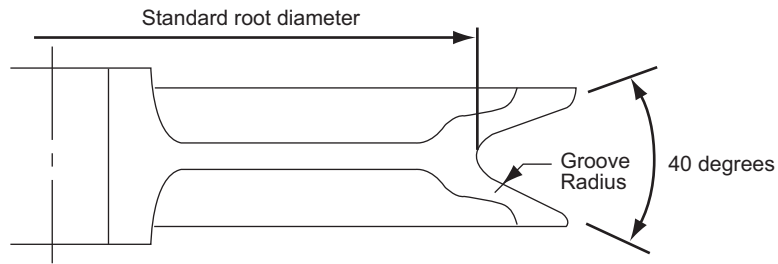

Unit : mm (inch)

Location	Item	Std. root diameter	Use limit	Remedy	Groove radius	See figure
Boom point	8	575 (22.638)	569.5 (22.413)	Replace or build-up	14.0 (0.551)	Fig.2-6 (P.2-8)
Idler sheave	9	575 (22.638)	569.5 (22.413)		14.0 (0.551)	
Auxiliary sheave	10	575 (22.638)	569.5 (22.413)		14.0 (0.551)	
Upper spreader	11	495 (19.488)	492.0 (13.370)		12.5 (0.492)	
Lower spreader	5	352 (13.858)	347.2 (13.669)		10.0 (0.394)	Fig.2-8 (P.2-9)
Jib point	8	549 (21.614)	543.8 (21.409)		14.0 (0.551)	Fig.2-7 (P.2-9)
Jib strut	9	549 (21.614)	543.8 (21.409)		14.0 (0.551)	Fig.2-7 (P.2-9)
Gantry peak	6	352 (13.858)	347.2 (13.669)		10.0 (0.394)	Fig.2-8 (P.2-9)

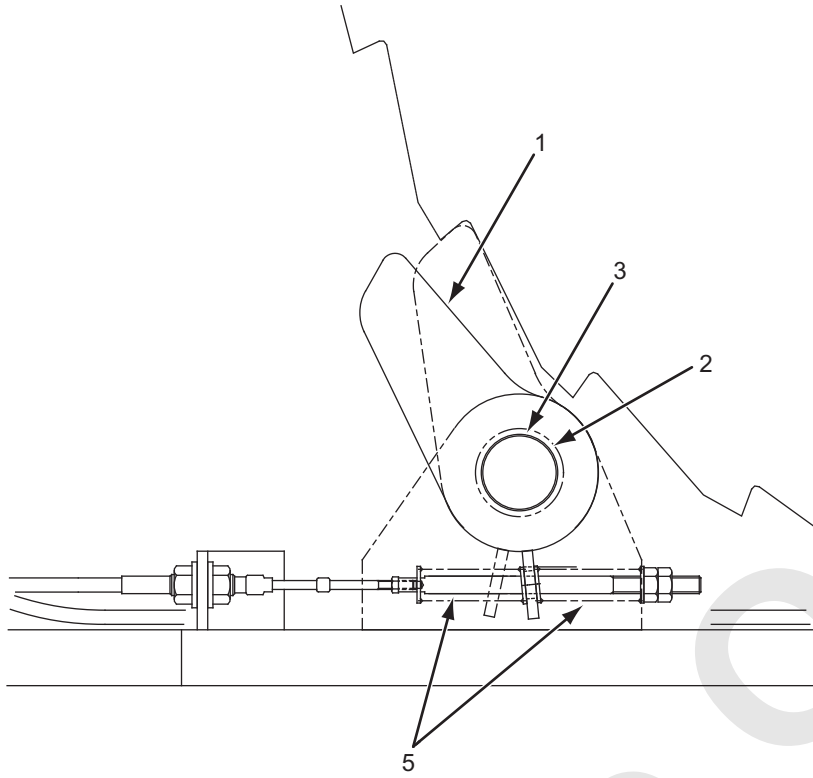

Fig.2-1 Front/rear drum lock assy

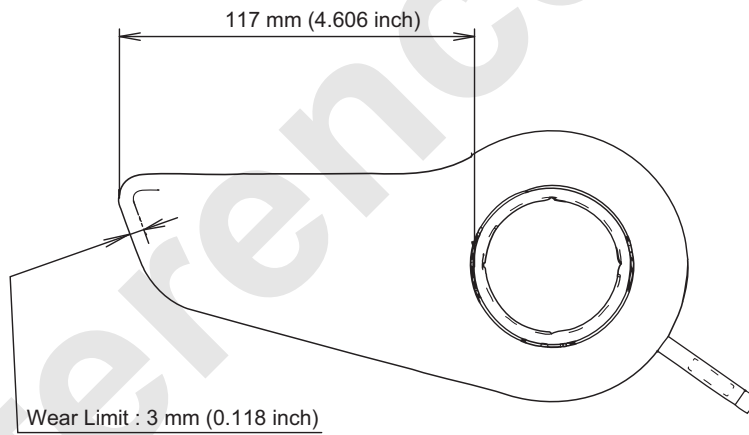

Fig.2-2 Pawl

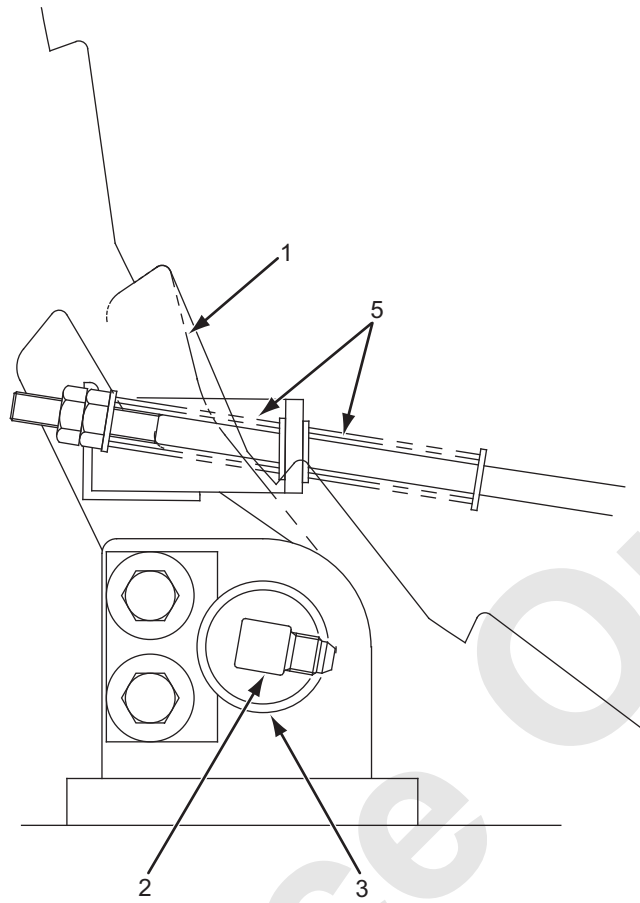

Fig.2-3 Boom drum lock assy

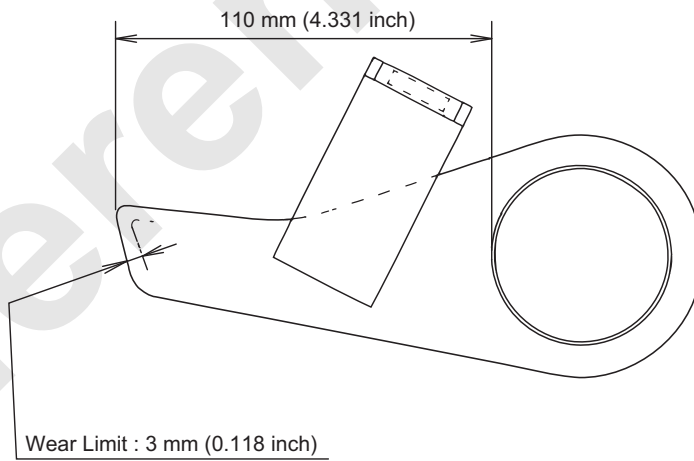

Fig.2-4 Pawl

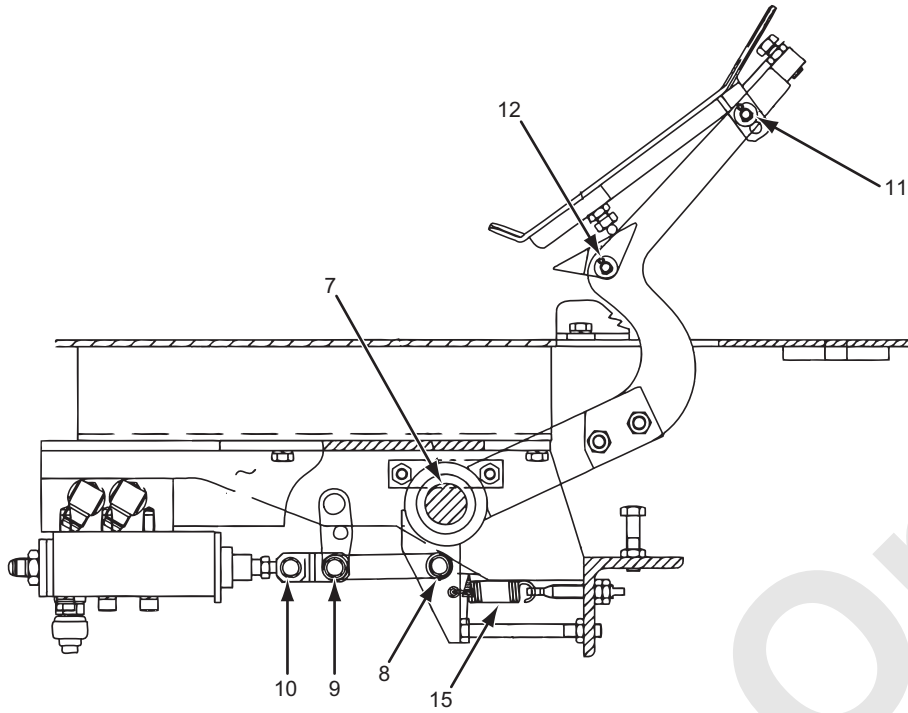

Fig.2-5 Brake pedal

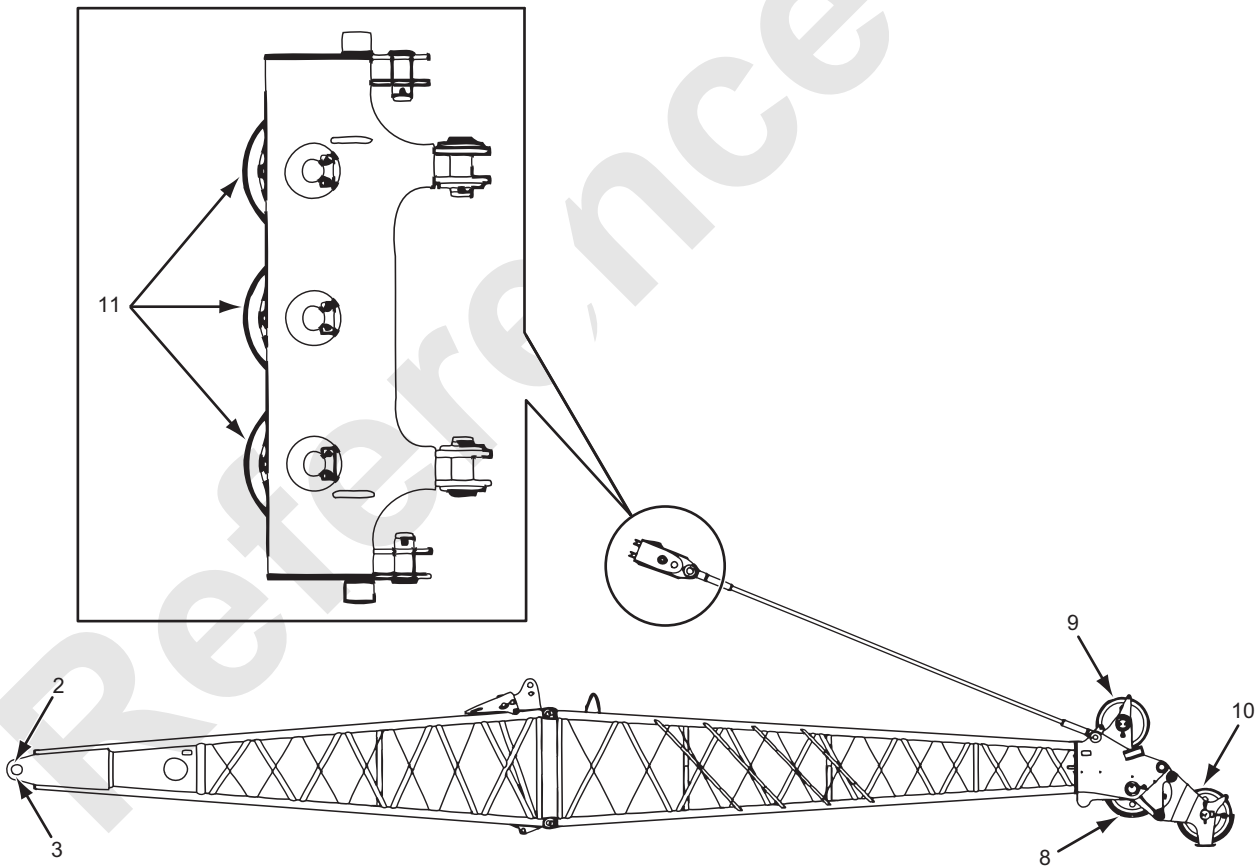

Fig.2-6 Crane assy

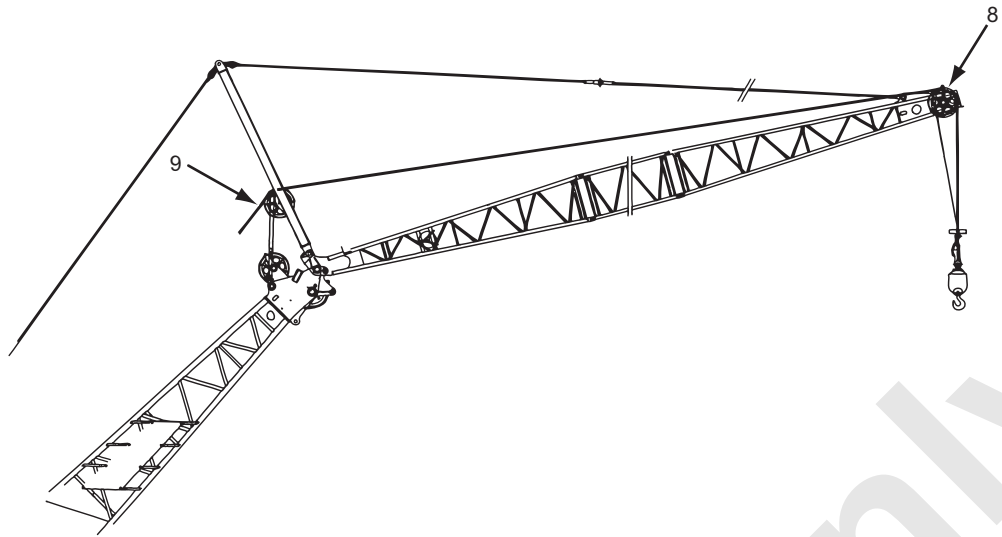

Fig.2-7 Jib assy

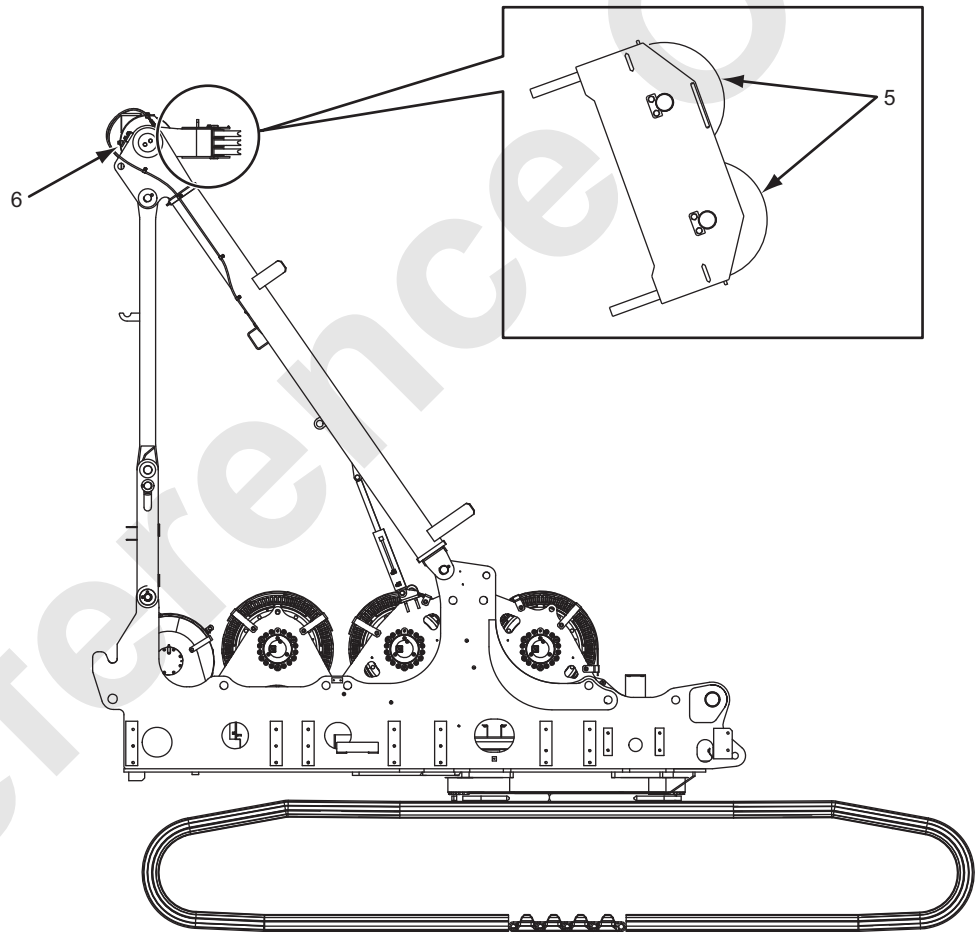

Fig.2-8 Gantry assy

2. MAINTENANCE STANDARDS TEST PROCEDURES

2.1.2 PROPEL DEVICE

1. Crawler shoe

- 914 mm

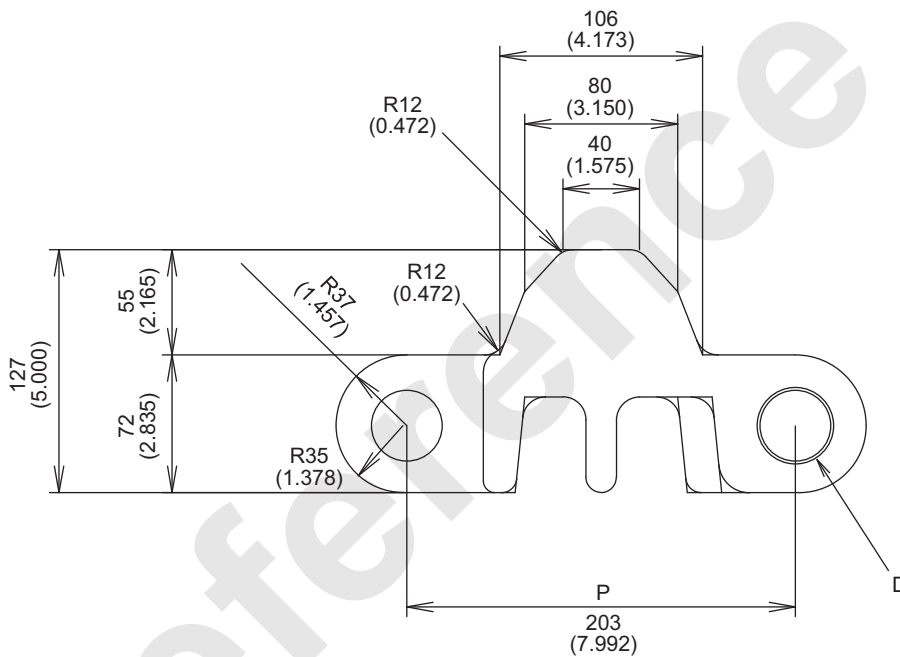
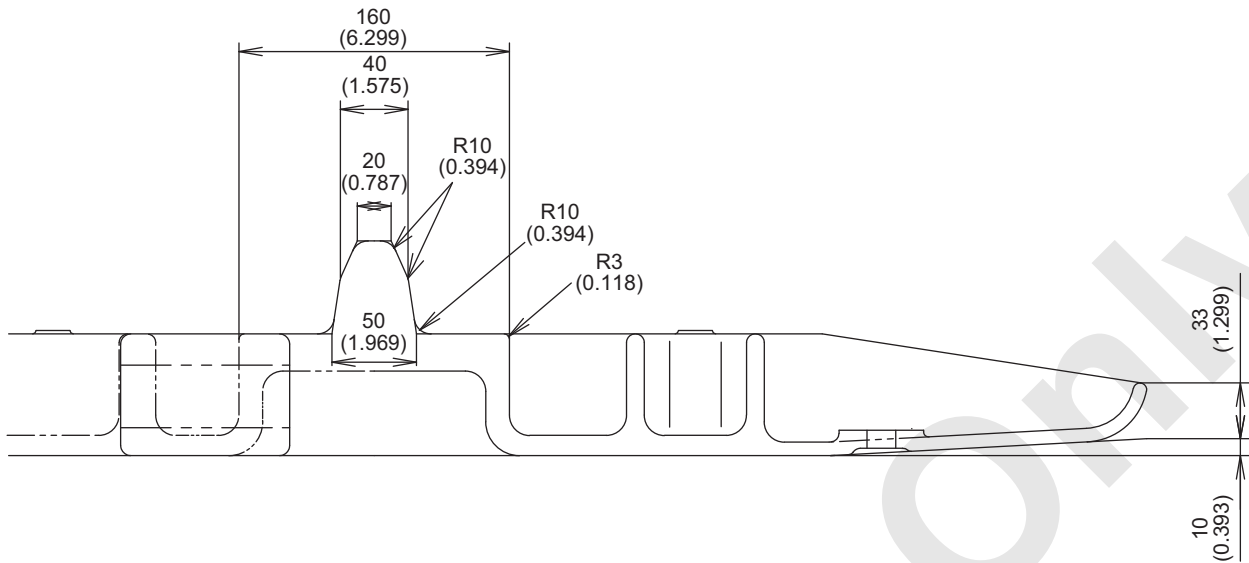

Wear limit : 2 mm (0.079 inch)
Remedy : Build-up or replace

Unit : mm (inch)

Unit : mm(inch)

	Std. dimension	Usable limit	Remedy
Pin hole (D)	36 to 38 (1.417 to 1.496)	39.0 (1.535)	Build-up or replace
Pin	36 ^{-0.4} (1.417)	34.0 (1.339)	
Pitch (P)	203.2 ^{-0.2} (8.000)	205.0 (8.071)	

Distance between pins when 6 pcs of shoes are connected and tension applied : 1213.2 to 1225.2 mm (47.764 to 48.236 inch)

- 800 mm

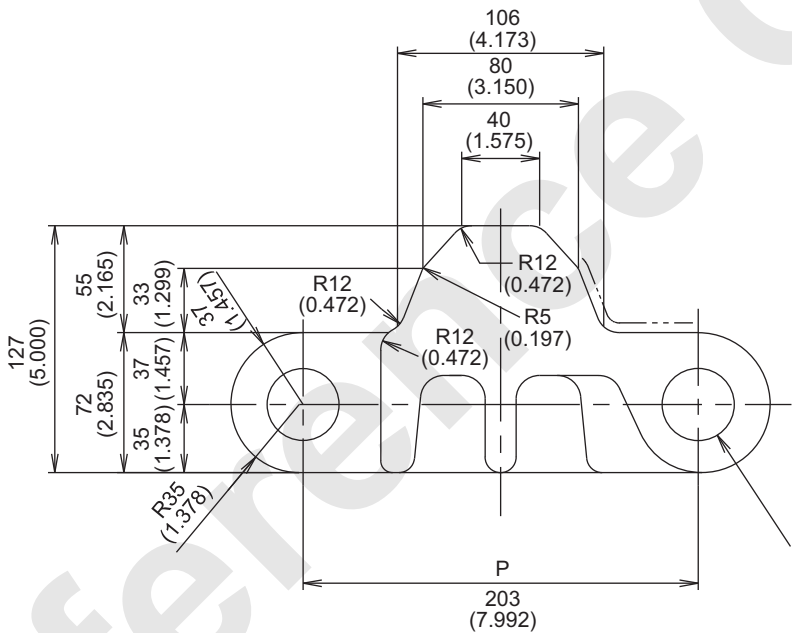
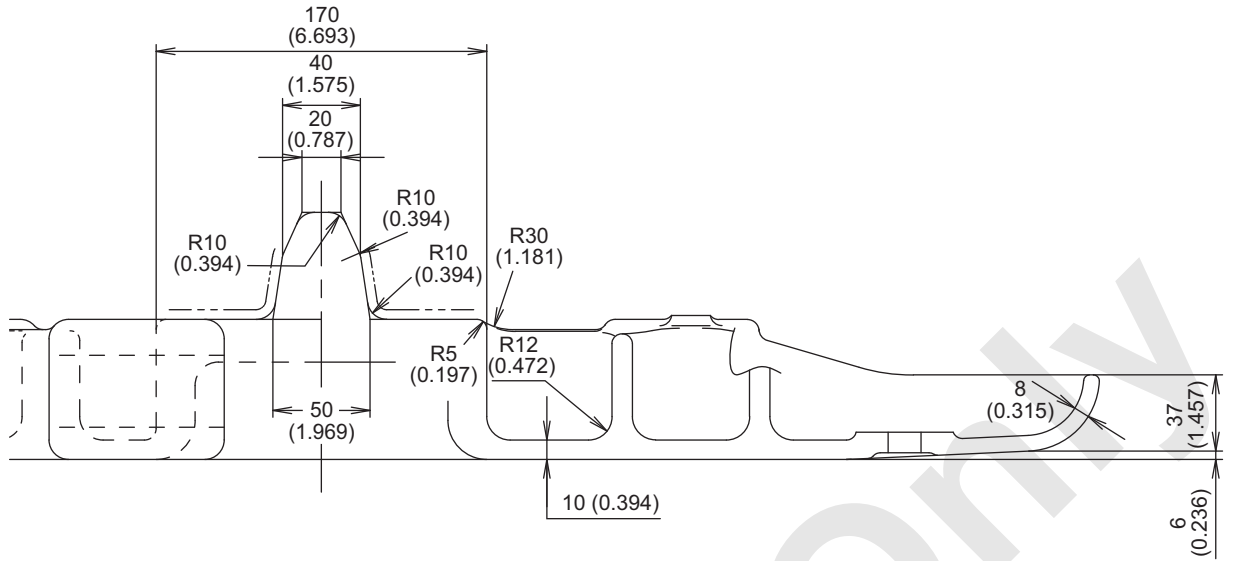

Wear limit : 2 mm (0.079 inch)
Remedy : Build-up or replace

Unit : mm (inch)

Unit : mm(inch)

	Std. dimension	Usable limit	Remedy
Pin hole (D)	36 to 38 (1.417 to 1.496)	39.0 (1.535)	Build-up or replace
Pin	36 ⁰ _{-0.4} (1.417)	34.0 (1.339)	
Pitch (P)	203.2 ⁰ _{-0.2} (8.000)	205.0 (8.071)	

Distance between pins when 6 pcs of shoes are connected and tension applied : 1213.2 to 1225.2 mm (47.764 to 48.236 inch)

2. MAINTENANCE STANDARDS TEST PROCEDURES

2. Drive tumbler

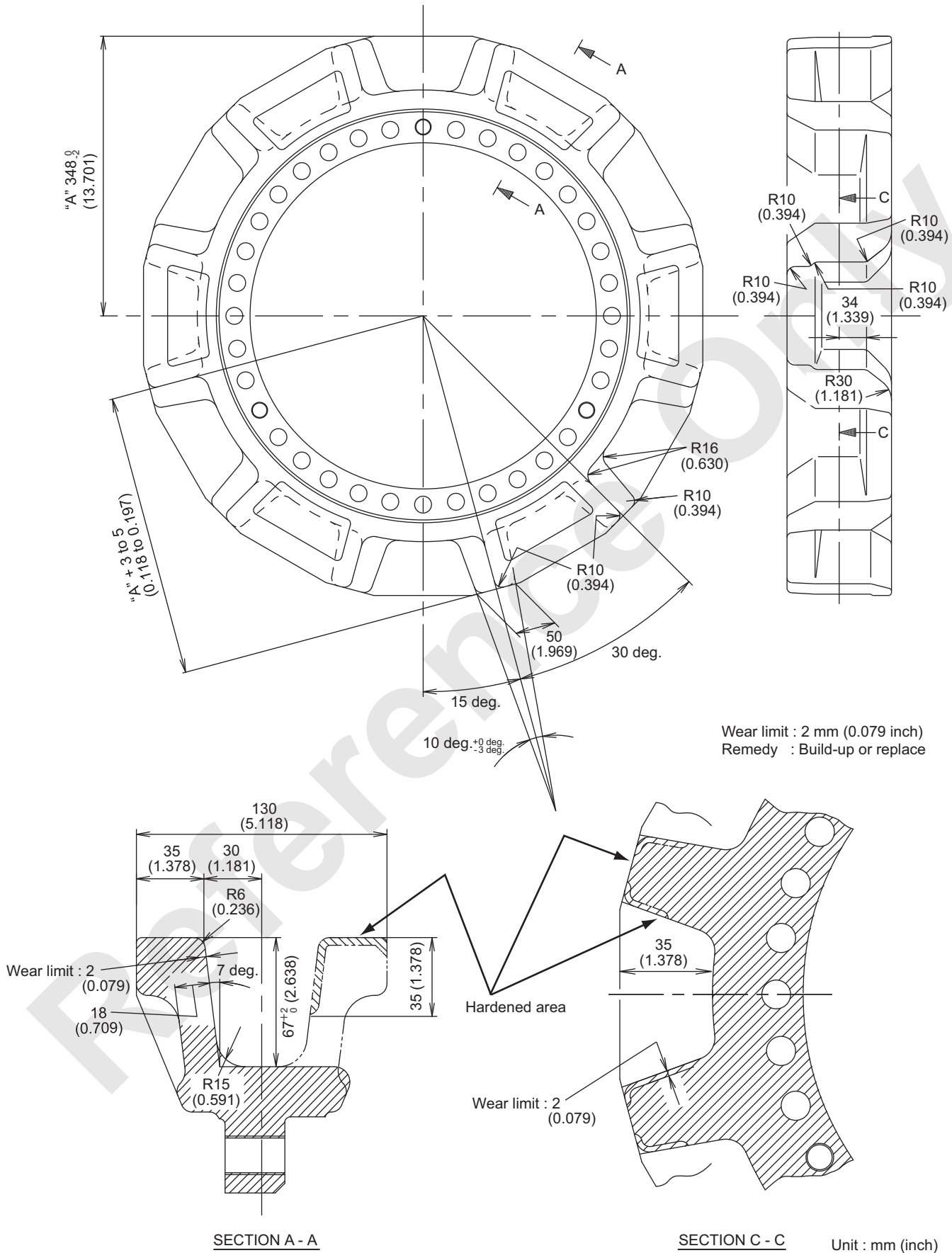

3. Idler

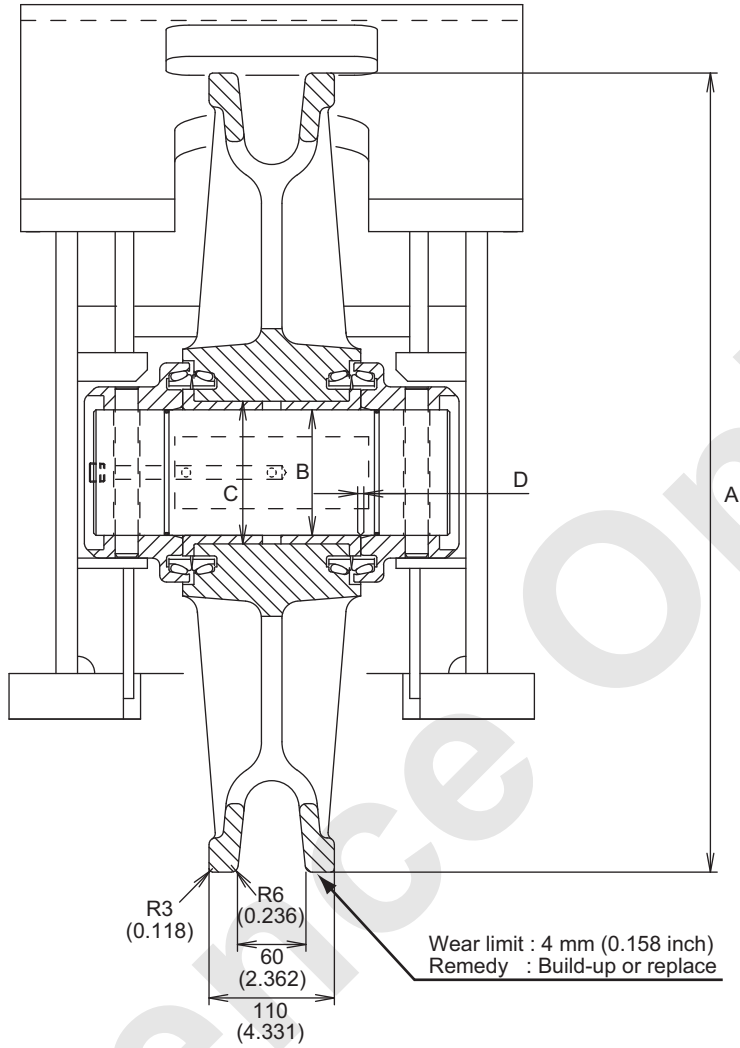

Unit : mm (inch)

Unit : mm (inch)

Symbol	Item	Std. dimension			Usable limit	Remedy
A	Outer diameter	Φ700 (27.559)			Φ692 (27.244)	Build-up or replace
B	Gap between shaft and bushing	Std. dimension	Tolerance		Standard	Allowable
			Φ110 (4.331)	Shaft		
Bore	+0.161 (+0.006) +0.139 (+0.006)					
C	Interference of sprocket and bushing	Φ125 (4.921)	Shaft	+0.117 (+0.005) +0.092 (+0.004)	Interference 0.052 (0.002) to 0.117 (0.005)	Interference 0 (0)
			Bore	+0.040 (+0.002) +0 (+0)		
D	Side clearance of idler (One side)	0.02 to 0.74 (0.001 to 0.029)			1.2 (0.047)	Replacement of bushing

2. MAINTENANCE STANDARDS TEST PROCEDURES

4. Track roller (Lower roller)

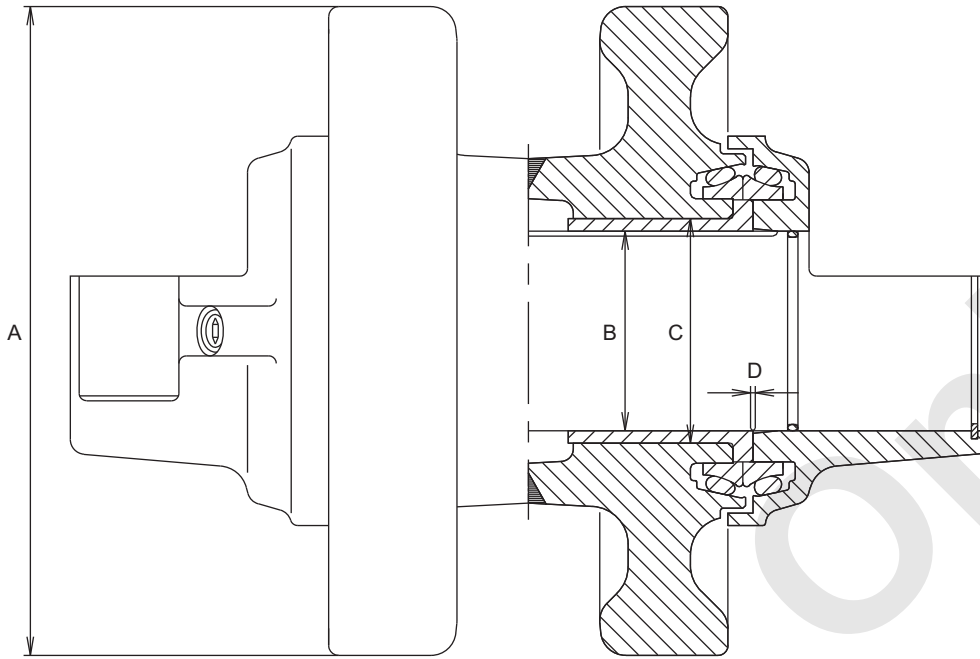

Unit : mm (inch)

Symbol	Item	Std. dimension			Usable limit	Remedy	
A	Outer deameter	Φ260 (10.236)			Φ252 (9.921)	Build-up or replace	
B	Gap between of shaft and bushing	Std. dimension Φ80 (3.150)	Tolerance		standard Gap 0.17 (0.007) to 0.23 (0.009)	Allowable Gap 0.8 (0.032)	Replacement of bushing
			Shaft	-0.05 (-0.002) -0.08 (-0.003)			
C	Interference of roller and bushing	Φ90 (3.543)	Shaft	+0.110 (+0.004) +0.080 (+0.003)	Interference 0.045 (0.002) to 0.11 (0.004)	Interference 0 (0)	Replace
			Bore	+0.035 (+0.001) 0 (0)			
D	Side clearance of roller (One side)	0.02 to 0.053 (0.001 to 0.047)			1.2 (0.047)	Replacement of bushing	

5. Guide roller (Upper roller)

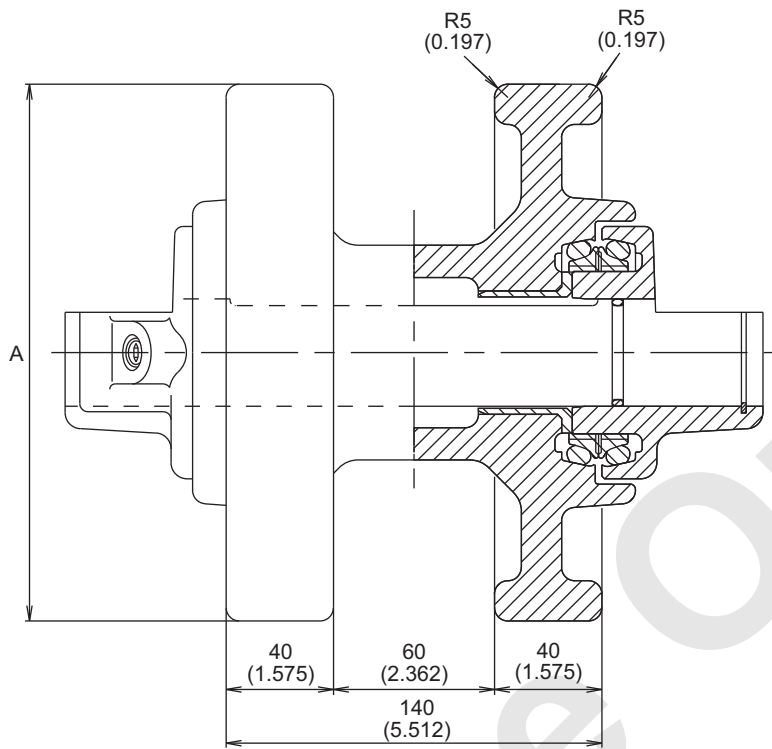

Unit : mm (inch)

Unit : mm (inch)				
Symbol	Item	Std. dimension	Usable limit	Remedy
A	Outer diameter	Φ200 (7.874)	Φ192 (7.559)	Build-up or replace

2. MAINTENANCE STANDARDS TEST PROCEDURES

6. Guide bar
LEFT SIDE
RIGHT SIDE

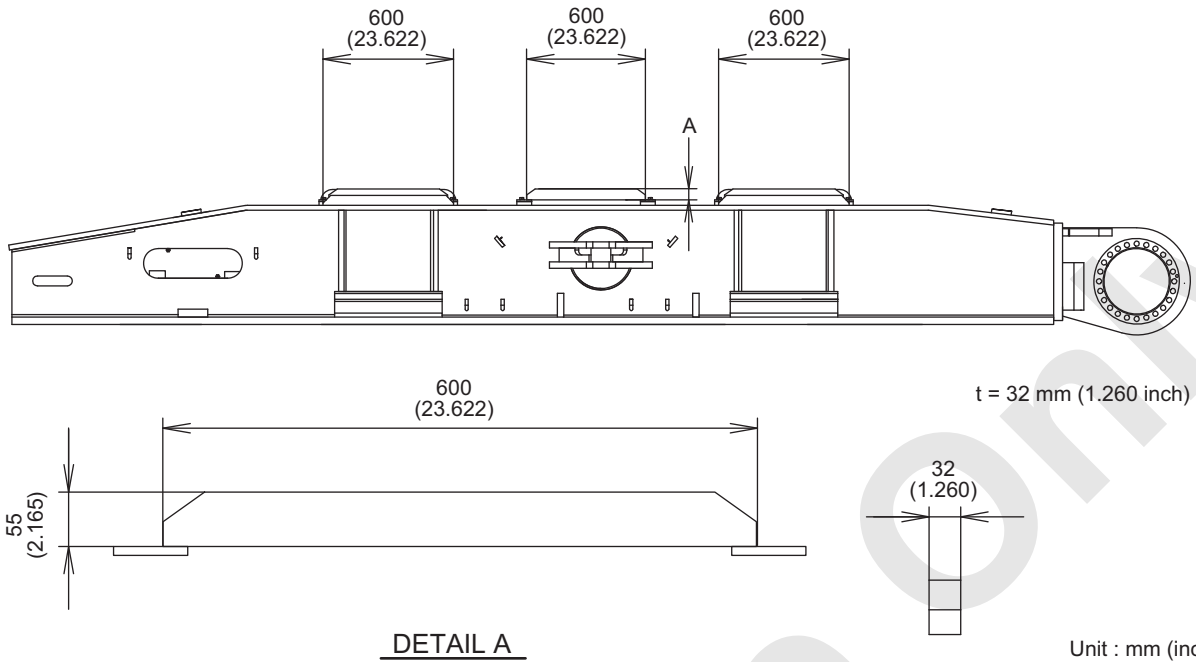

Unit : mm (inch)				
Symbol	Item	Std. dimension	Usable limit	Remedy
A	Height of guide bar	55 (2.165)	30 (1.181)	Build-up or replace

7. Propel brake plate

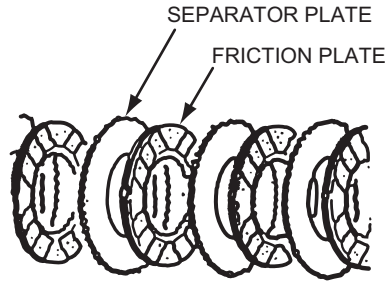

Unit : mm (inch)

Name of plate	Number	Std. dimension (Total)	Wear limit (Total)	Std. brake torque
Friction plate	3	16.92 to 18.32 mm	-0.7 mm	More than 426 N-m
Separator plate	4	(0666 to 0.721 inch)	(-0.028 inch)	(More than 314 lbs-ft)

Reference Only

2.2 PERFORMANCE STANDARD AND TEST PROCEDURE

1. TERMINOLOGY

Standard value : Standard of assembling new machine.

When the value exceeds the standard, repair or replace the part as required to maintain machine performance and or safety.

Temperature of oil : It means temperature of hydraulic oil.

2. As to the items of which limit of use is not shown, referring to standard value as the guidance, repair or replace the part as required.



Operate the machine according to the sign from a designated personnel.

Draw the ropes around the area where the machine operates to keep out everyone.

Check that the overhoist prevention (for hook/boom) correctly operates.

Lock all functions that are not used.

Do not attempt sudden startup/sudden stop.

2.2.1 OPERATING SPEED

No.	Item	Test condition	Test procedure	Standard value
1	Boom hoist rope speed	Mode : Power mode Engine min ⁻¹ : High idling Temperature of oil : 45 to 55°C (113 to 131°F) Boom Length : Basic boom Loading : No load	Measure the time taken to rotate drum 10 times. (Start measuring after rotation becomes stable.) Take average of 3 times measuring.	8.8 to 10.6 sec
2	Front and rear drum rope speed	Mode : Power mode Engine min ⁻¹ : High idling Temperature of oil : 45 to 55°C (113 to 131°F) Loading : No load	Measure the time taken to rotate drum 10 times. (Start measuring after rotation becomes stable.) Take average of 3 times measuring.	Low = (Trimmer low) 17.0 to 20.0 sec High = (Trimmer high) 9.1 to 10.9 sec
3	Swing speed	Mode : Power mode Engine min ⁻¹ : High idling Temperature of oil : 45 to 55°C (113 to 131°F) Boom Length : Basic boom Loading : No load Swing mode : Free high	Measure the time taken to rotate machine one time. Measure the time for 2nd rotation after 1st preliminary rotation. Take average of 3 times measuring.	14.1 to 16.7 sec
4	Propel speed	Mode : Power mode Engine min ⁻¹ : High idling Temperature of oil : 45 to 55°C (113 to 131°F) Boom Length : Basic boom Place : Firm and level ground	Measure the time taken to propel machine the distance of 20 m (66 ft). Propel machine first preliminary more than 2 m (6.6 ft) before starting the measuring. Take average of 3 times measuring.	Low = 60.1 to 69.8 sec High = 40.6 to 47.3 sec
5	Propelling deflection	Mode : Standard mode Engine min ⁻¹ : High idling Temperature of oil : 45 to 55°C (113 to 131°F) Boom Length : Basic boom Place : Firm and level ground	Measure the deflection amount resulted from propelling the distance of 20 m (66 ft). Propel machine first preliminary more than 2 m (6.6 ft) before starting the measuring. Take average of 3 times measuring.	Within 600 mm (23.6 inch)

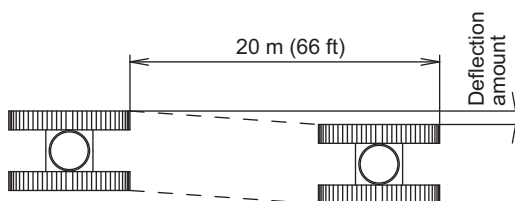

2. MAINTENANCE STANDARDS TEST PROCEDURES

2.2.2 POINT AND METHOD OF MEASURING PRESSURE

Use a pressure gauge which has a surplus of more than 10 MPa for pressures to be measured and which has passed the inspection.

Prior to pressure measurement, clean the port for pressure measurement so as to be free from oil and dust.

Connector and hose for measuring pressure.
 Connector: 9999406548
 Hose: 9999429916

No.	Item	Test condition	Test procedure	Standard value
1	Main <ul style="list-style-type: none"> • Propel right • Boom • Rear drum 1st speed • Front drum 2nd speed 	<ul style="list-style-type: none"> • Engine speed : High idling • Temperature of oil : 45 to 55° C (113 to 131° F) • Mode : Power mode 	<ol style="list-style-type: none"> 1. Lower the boom onto the ground. 2. Lock the boom drum with the drum lock. 3. Make the valve relieved by boom drum winch lowering operation. 	31.9 MPa (4,627 psi)

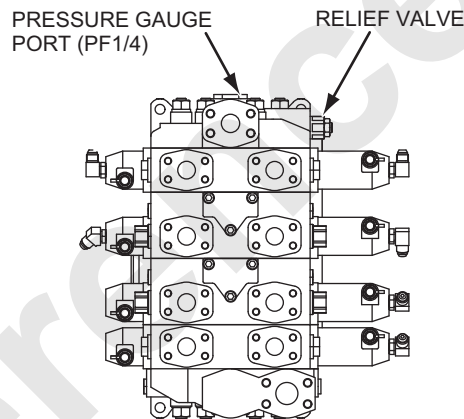

2. MAINTENANCE STANDARDS TEST PROCEDURES

No.	Item	Test condition	Test procedure	Standard value
2	Main <ul style="list-style-type: none"> • Propel left • Rear drum 2nd speed • Front drum 1st speed 	<ul style="list-style-type: none"> • Engine speed : High idling • Temperature of oil : 45 to 55° C (113 to 131° F) • Mode : Power mode 	<ol style="list-style-type: none"> 1. Lower the front drum hook onto the ground. 2. Lock the front winch drum with the drum lock. 3. Make the valve relieved by front drum winch lowering operation. (1st speed detent) 	31.9 MPa (4,627 psi)

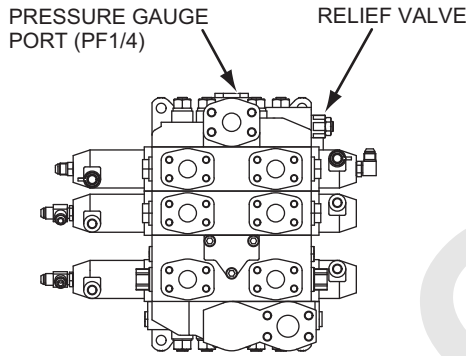

No.	Item	Test condition	Test procedure	Standard value
3	Swing	<ul style="list-style-type: none"> • Engine speed : High idling • Temperature of oil : 45 to 55° C (113 to 131° F) • Swing mode : Free high • Mode : Power mode 	<ol style="list-style-type: none"> 1. Lock the upper not to turn with the swing lock pin and parking brake. 2. Make the valve relieved by swing operation. 	27.5 MPa (3,989 psi)

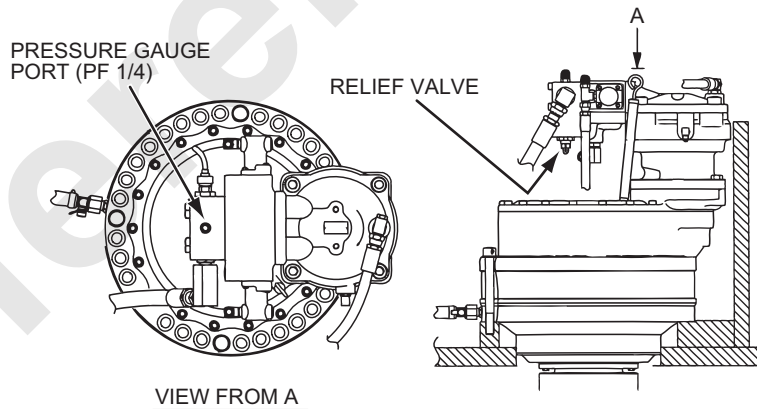

2. MAINTENANCE STANDARDS TEST PROCEDURES

No.	Item	Test condition	Test procedure	Standard value
4	Control Circuit (Primary pressure)	<ul style="list-style-type: none"> Temperature of oil : 45 to 55° C (113 to 131° F) 	Remove the cap of plug installed in valve block, and instal the pressure gauge.	Relief valve : 7.0 MPa (1,015 psi) (Low idling) Reduction valve : 5.4 MPa (783 psi) (Low idling)

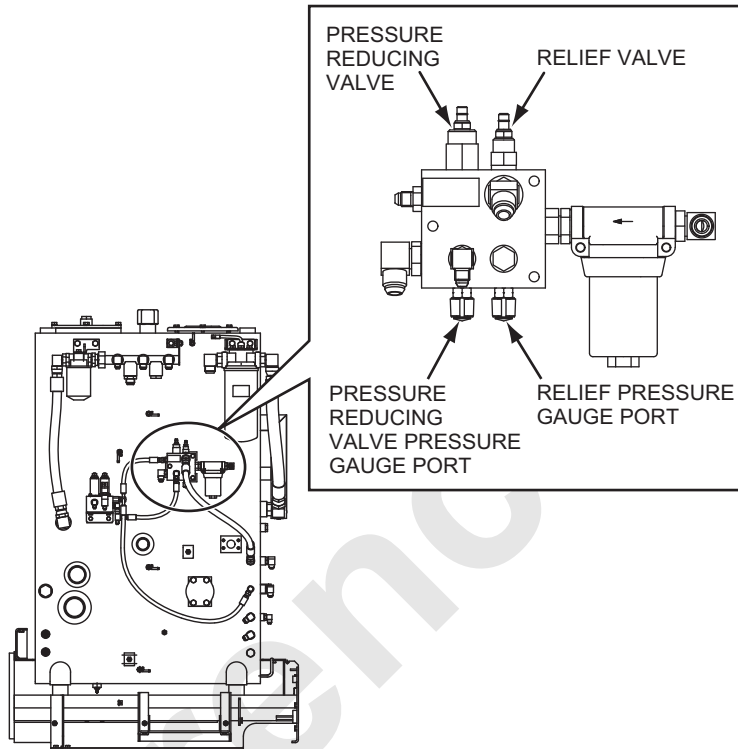

No.	Item	Test condition	Test procedure
5	Control Circuit (Secondary pressure)	<ul style="list-style-type: none"> Engine speed : Low idling Temperature of oil : 45 to 55° C (113 to 131° F) 	Operate the control lever for the section to be measured. (Operate the speed adjusting knob to the Max. position)
			Take pressure out from the quick coupler of the control valve spool end.
	Standard value		
	Front/rear drum	2.65 to 2.94 MPa (384 to 426 psi)	
	Propel	1.42 to 1.62 MPa (206 to 235 psi)	
	Swing	1.62 to 1.92 MPa (235 to 278 psi)	
	Third drum	2.65 to 2.94 MPa (384 to 426 psi)	
	Boom	2.50 to 2.79 MPa (363 to 405 psi)	

2. MAINTENANCE STANDARDS TEST PROCEDURES

No.	Item	Test condition	Test procedure	Standard value
6	Crawler extening	<ul style="list-style-type: none"> • Engine speed : High idling • Temperature of Hydraulic oil : 45 to 55° C (113 to 131° F) 	<ol style="list-style-type: none"> 1. Insert the crawler fixing pins to fix the crawlers. 2. Make the valve relieved by operating crawler retraction or extension. 	Extension 17.0 MPa (2,466 psi) Retraction 20.6 MPa (2,988 psi)

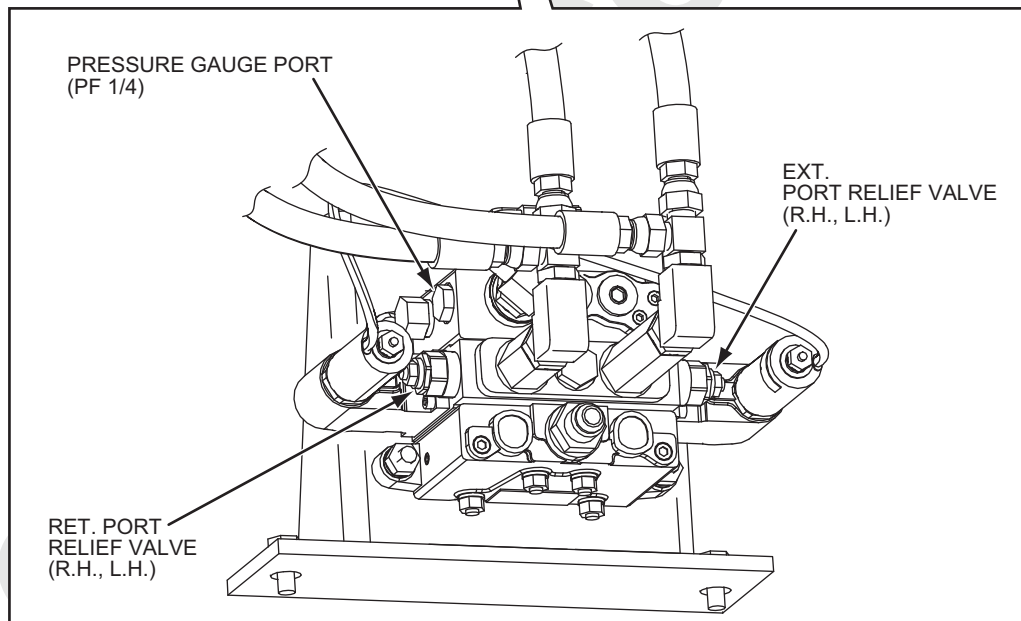
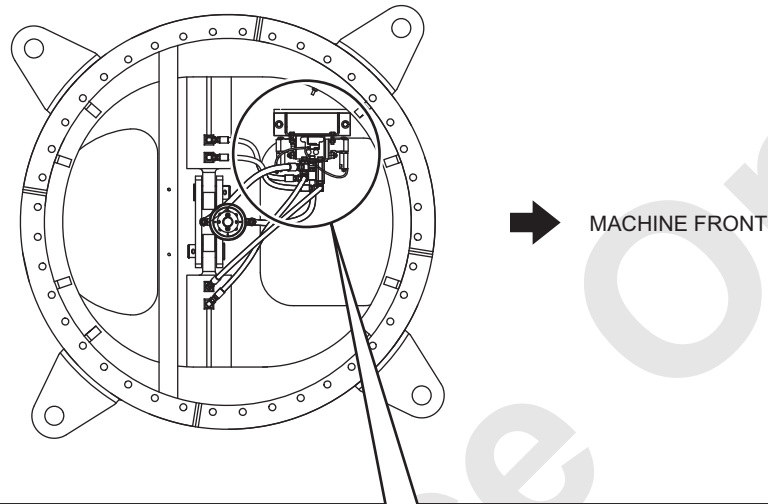

2. MAINTENANCE STANDARDS TEST PROCEDURES

No.	Item	Test condition	Test procedure	Standard value
7	Gantry raising/ lowering	<ul style="list-style-type: none"> Engine speed : High idling Temperature of Hydraulic oil : 45 to 55° C (113 to 131° F) 	<ol style="list-style-type: none"> Raise the gantry high, and fix it with the gantry fixing pin. Make the valve relieved by raising or lowering the gantry operation. 	Port relief set Raise : 20.6 MPa (2,988 psi) Lower : 4.9 MPa (711 psi)

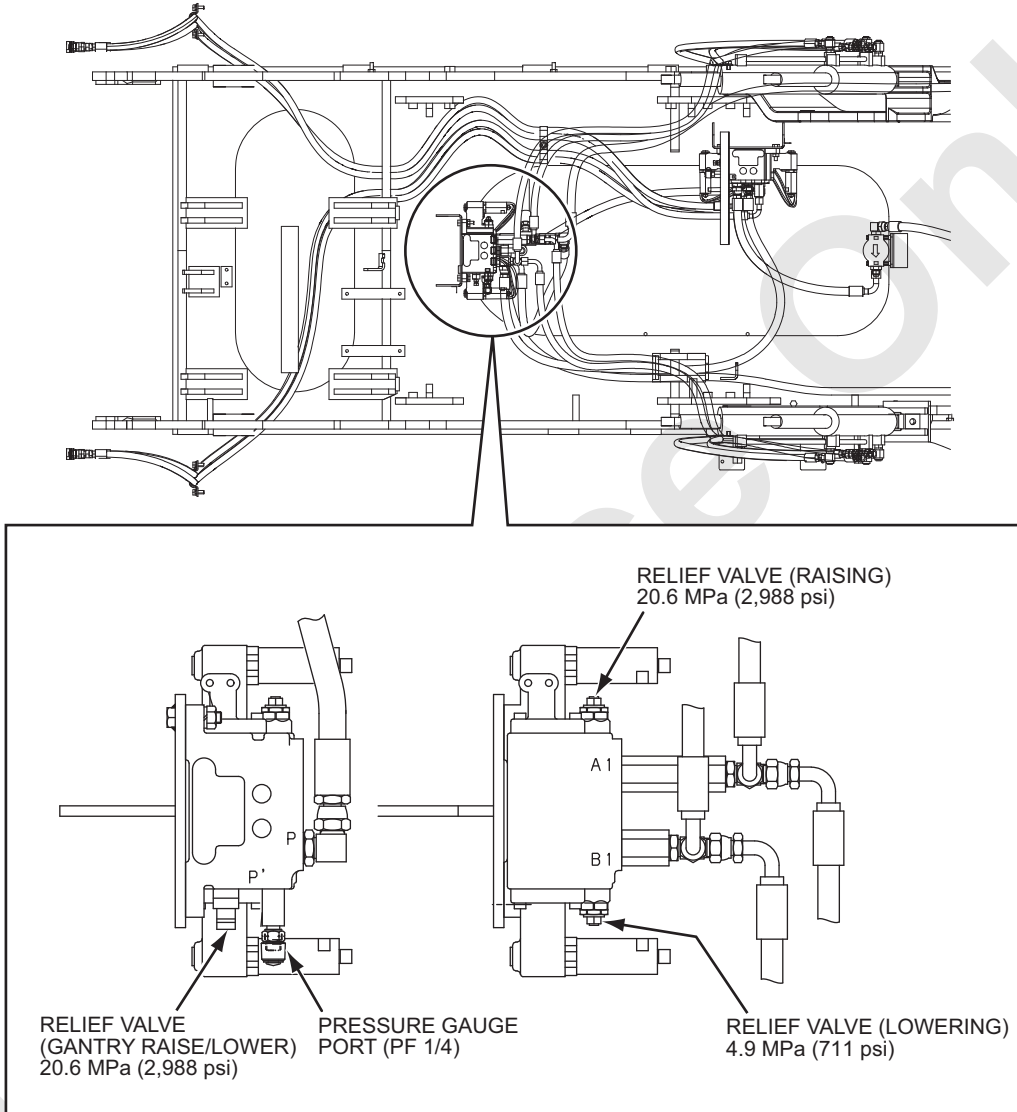

2.2.3 SLEWING RING

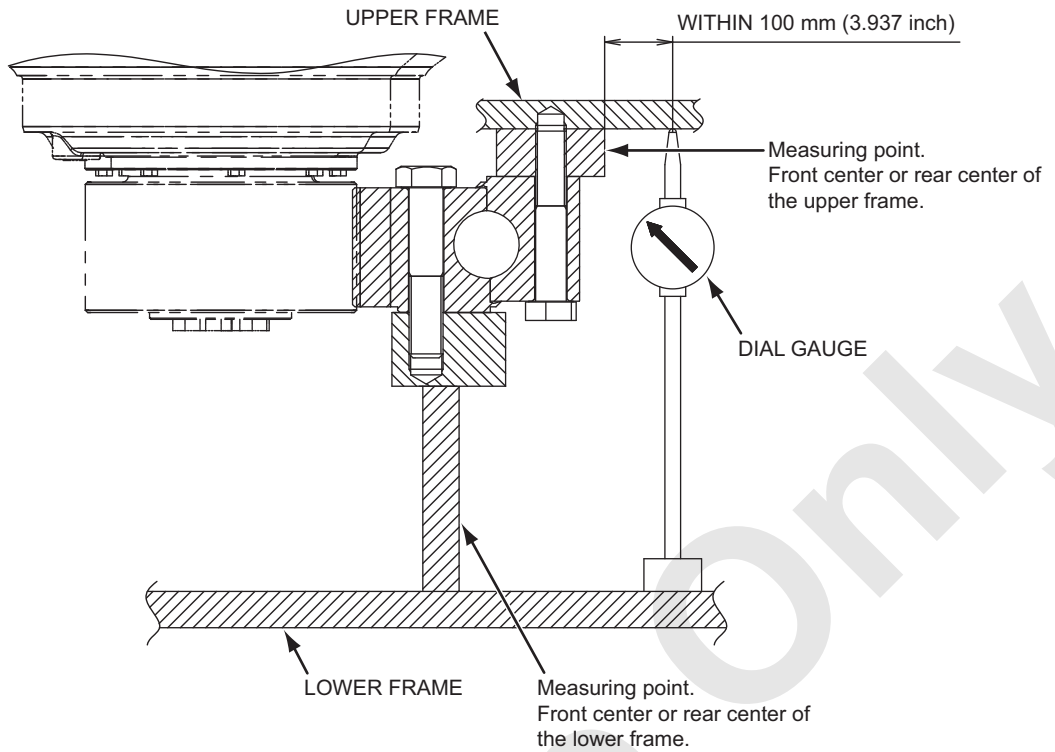

COUNTERWEIGHT : FULL

Condition of measurement	Amount of play
Boom length : 12.2 m (40 ft)	Less than 3 mm (0.118 inch)
Radius : 5.5 m (18 ft)	
Load : 51.4 t (113,318 lbs)	

Reference Only

3. GENERAL WORK STANDARD

Reference Only

Reference Only

3.1 TIGHTENING TORQUE OF CAP SCREWS AND NUTS

3.1.1 STANDARD TIGHTENING TORQUE

Unless otherwise specified, torque all screws and nuts on this machine to the values shown in the following tables.

METRIC COARSE THREADS (PLATED)

Nominal size	Classification			
	4T		7T	
	Tightening torque N-m (ft-lbs)		Tightening torque N-m (ft-lbs)	
	Dry	Lubricated	Dry	Lubricated
M6	4.6 to 5.6 (0.47 to 0.57)	3.9 to 4.7 (0.40 to 0.48)	10 to 12.2 (1.02 to 1.24)	8.4 to 10.2 (0.85 to 1.05)
M8	11.1 to 12.2 (8.1 to 9.9)	10.3 to 10.5 (6.9 to 8.5)	24.4 to 30.1 (18.2 to 22.2)	20.2 to 24.8 (14.9 to 18.3)
M10	22 to 27 (16.3 to 19.9)	18.5 to 22.7 (13.7 to 16.7)	47.6 to 58.2 (35.1 to 42.9)	40.6 to 49.6 (29.9 to 36.5)
M12	37.1 to 45.3 (27.3 to 33.3)	32.7 to 39.9 (24 to 29.4)	81.0 to 99.2 (59.8 to 73)	68.8 to 84.0 (50.7 to 61.9)
M14	59.1 to 72.3 (43.6 to 53.2)	50.2 to 61.5 (37.1 to 45.3)	129 to 157 (94.5 to 115.5)	109 to 133 (79.9 to 97.7)
M16	90 to 110 (66.2 to 81)	75.9 to 92.7 (55.9 to 68.3)	194 to 238 (143 to 175)	163 to 199 (121 to 147)
M18	123 to 151 (91 to 111)	105 to 129 (77.3 to 94.5)	274 to 334 (202 to 246)	229 to 281 (169 to 207)
M20	174 to 212 (128 to 156)	146 to 178 (107 to 131)	379 to 463 (279 to 341)	318 to 388 (234 to 286)
M22	229 to 281 (169 to 207)	194 to 238 (143 to 175)	503 to 615 (371 to 453)	423 to 517 (312 to 382)
M24	300 to 366 (220 to 250)	238 to 292 (175 to 215)	643 to 787 (474 to 580)	520 to 636 (382 to 468)
M27	432 to 528 (319 to 389)	353 to 431 (260 to 318)	943 to 1153 (696 to 850)	768 to 938 (579 to 707)
M30	591 to 723 (436 to 532)	494 to 604 (364 to 444)	1279 to 1563 (942 to 1152)	1075 to 1315 (793 to 969)
M33	794 to 970 (585 to 715)	661 to 809 (488 to 596)	1721 to 2101 (1267 to 1549)	1446 to 1768 (1066 to 1302)
M36	1023 to 1251 (754 to 922)	856 to 1046 (630 to 770)	2205 to 2659 (1625 to 1985)	1843 to 2253 (1358 to 1660)

3. GENERAL WORK STANDARD

METRIC FINE THREADS (PLATED)

Nominal size	Classification			
	4T		7T	
	Tightening torque N-m (ft-lbs)		Tightening torque N-m (ft-lbs)	
	Dry	Lubricated	Dry	Lubricated
M8	11.6 to 14.2 (8.6 to 10.4)	9.8 to 12 (7.2 to 8.8)	25.6 to 31.2 (18.8 to 23)	21.1 to 25.9 (15.6 to 19)
M10	22.9 to 28.1 (16.9 to 20.7)	19.4 to 23.8 (14.3 to 17.5)	49.4 to 60.4 (36.4 to 44.4)	42.7 to 51.7 (31.2 to 38.2)
M12	40.6 to 49.6 (29.9 to 36.5)	34.4 to 42 (25.4 to 31.6)	87.3 to 106.7 (64.3 to 78.7)	73.2 to 89.4 (53.9 to 65.9)
M16	94 to 116 (69.6 to 85)	79.4 to 97 (58.5 to 71.5)	202 to 248 (149 to 183)	172 to 210 (127 to 155)
M20	185 to 227 (137 to 167)	157 to 191 (116 to 142)	406 to 496 (299 to 365)	335 to 409 (247 to 301)
M24	318 to 388 (234 to 286)	265 to 323 (195 to 239)	688 to 840 (507 to 619)	573 to 701 (422 to 516)
M30	635 to 777 (468 to 572)	529 to 647 (390 to 476)	1393 to 1703 (1027 to 1255)	1156 to 1412 (851 to 1103)
M36	1058 to 1294 (779 to 953)	882 to 1078 (650 to 794)	2311 to 2825 (1703 to 2081)	1922 to 2350 (1417 to 1731)

COARSE THREADS UNC

Nominal size	Classification					
	Coarse Threads UNC					
	Tightening torque N-m (ft-lbs)					
	Grade 2		Grade 5		Grade 8	
	Dry	Lubricated	Dry	Lubricated	Dry	Lubricated
1/4	7.8 (5.79)	6.9 (5.06)	12.7 (9.40)	10.8 (7.96)	17.7 (13.0)	14.7 (10.8)
5/16	15.7 (11.6)	13.7 (10.1)	25.5 (18.8)	21.6 (15.9)	35.3 (26.0)	30.4 (22.4)
3/8	28.4 (21.0)	23.5 (17.4)	44.1 (32.6)	37.3 (27.5)	61.8 (45.6)	52.0 (38.3)
7/16	44.1 (32.5)	37.3 (27.5)	68.6 (50.6)	57.9 (42.7)	97.1 (71.6)	81.4 (60.0)
1/2	68.6 (50.6)	57.9 (42.7)	105.9 (78.1)	89.2 (65.8)	149.1 (110)	125.5 (92.6)
9/16	98.1 (72.3)	82.4 (60.8)	152.0 (112)	127.5 (94.0)	215.7 (159)	180.4 (133)
5/8	137.3 (101)	115.7 (85.3)	215.7 (159)	178.5 (132)	304.0 (224)	255.0 (188)
3/4	245.2 (181)	205.9 (152)	372.7 (275)	313.8 (232)	529.6 (391)	441.3 (325)
7/8	284.4 (210)	245.2 (181)	598.2 (441)	500.1 (369)	843.4 (622)	706.1 (521)
1	343.2 (253)	294.2 (217)	892.4 (658)	745.3 (550)	1255.3 (926)	1059.1 (781)
1 1/8	500.1 (369)	421.7 (311)	1118.0 (825)	931.6 (687)	1804.4 (1331)	1510.2 (1114)
1 1/4	696.3 (514)	578.6 (427)	1559.3 (1150)	1304.3 (962)	2520.3 (1859)	2118.0 (1562)
1 3/8	912.0 (673)	764.9 (564)	2049.6 (1512)	1716.2 (1266)	3314.6 (2445)	2785.1 (2054)
1 1/2	1216.0 (897)	1019.9 (752)	2716.4 (2004)	2275.1 (1678)	4403.2 (3248)	3687.3 (2720)

FINE THREADS UNF

Nominal size	Classification					
	Fine Threads UNF					
	Tightening torque N-m (ft-lbs)					
	Grade 2		Grade 5		Grade 8	
	Dry	Lubricated	Dry	Lubricated	Dry	Lubricated
1/4	8.8 (6.51)	7.8 (5.79)	13.7 (10.1)	11.8 (8.68)	20.6 (15.2)	16.7 (12.3)
5/16	17.7 (13.2)	14.7 (10.8)	27.5 (20.3)	23.5 (17.4)	39.2 (28.9)	33.3 (24.6)
3/8	31.4 (23.1)	26.5 (19.5)	48.1 (35.4)	40.2 (29.7)	68.6 (50.6)	56.9 (42.0)
7/16	49.0 (36.2)	41.2 (30.4)	75.5 (55.7)	62.8 (46.3)	105.9 (78.1)	89.2 (65.8)
1/2	75.5 (55.7)	62.8 (46.3)	116.7 (86.1)	97.1 (71.6)	164.8 (122)	137.3 (101)
9/16	106.9 (78.8)	90.2 (66.5)	165.7 (122)	138.3 (102)	235.4 (174)	195.2 (144)
5/8	152.0 (112)	126.5 (93.3)	235.4 (174)	196.1 (145)	333.4 (246)	274.6 (203)
3/4	264.8 (195)	215.7 (159)	411.9 (304)	343.2 (253)	568.8 (420)	480.5 (354)
7/8	304.0 (224)	245.2 (181)	647.2 (477)	539.4 (398)	912.0 (673)	755.1 (557)
1	372.7 (275)	304.0 (224)	961.1 (709)	804.1 (593)	1353.3 (998)	1127.8 (832)
1 1/8	549.2 (405)	451.1 (333)	1216.0 (897)	1019.9 (752)	1971.1 (1454)	1647.5 (1215)
1 1/4	755.1 (557)	627.6 (463)	1500.4 (1107)	1402.4 (1034)	2736.1 (2018)	2275.1 (1678)
1 3/8	1010.1 (745)	843.4 (622)	2265.3 (1671)	1882.9 (1389)	3667.7 (2705)	3049.9 (2249)
1 1/2	1333.7 (984)	1108.2 (817)	2981.2 (2199)	2481.1 (1830)	4834.7 (3566)	4020.7 (2966)

Use thread lock to prevent bolt and nut from loosening.

(LOCTITE #242, PART No. = KSP1)

Before using thread lock wash rust, dirt and oil on thread area and dry completely.



MANITOWOC GENUINE THREAD LOCK
(LOCTITE #242)

3. GENERAL WORK STANDARD

3.1.2 TIGHTENING TORQUE OF HYDRAULIC FITTINGS

Excessive or insufficient tightening of hose or tube fittings can cause oil leak and deformation or damage to the metal fittings.

Therefore, to secure and obtain good fixing and performance of fittings it is necessary to tighten to the proper torque. The follows are the recommended torques.

(1) BITE TYPE TUBE FITTINGS

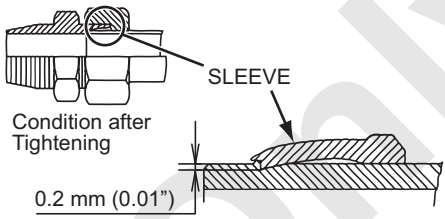
Size in mm (inch) (Outside diameter × thickness)	Tightening torque in N-m (ft-lbs)	Remarks
		
10 (0.364) X 1.5 (0.059)	49 to 69 (36 to 51)	
15 (0.591) X 2.0 (0.079)	127 to 157 (94 to 116)	
18 (0.709) X 2.5 (0.098)	157 to 167 (116 to 123)	
22 (0.866) X 3.0 (0.118)	196 to 216 (145 to 159)	
28 (1.102) X 4.0 (0.157)	245 to 284 (181 to 210)	
35 (1.378) X 5.0 (0.197)	324 to 353 (239 to 260)	

(2) SPLIT FLANGES

(From SAE Standard)

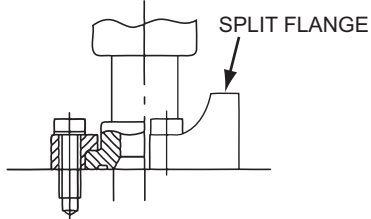
Size	Tightening torque in N-m (ft-lbs)		Remarks
	3000 psi (210 kg/cm ²)	6000 psi (420 kg/cm ²)	
1/2"	20 to 25 (14.5 to 19)	-	
3/4"	28 to 39 (21 to 29)	34 to 45 (25 to 33)	
1"	37 to 48 (27 to 35)	56 to 68 (42 to 50)	
1 1/4"	48 to 62 (35 to 45)	84 to 101 (62 to 74)	
1 1/2"	62 to 78 (45 to 58)	158 to 180 (116 to 133)	
2"	74 to 93 (54 to 69)	271 to 294 (200 to 217)	

(3) FLARE TYPE TUBE FITTINGS (30° FLARE, PF THREADS)

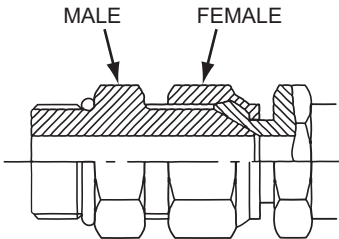
Size	Tightening torque in N-m (ft-lbs)	Remarks
1/4"	25 to 34 (18 to 25)	
3/8"	49 to 69 (36 to 51)	
1/2"	59 to 78 (43 to 58)	
3/4"	118 to 157 (87 to 116)	
1"	147 to 186 (108 to 137)	
1 1/4"	167 to 226 (123 to 166)	
1 1/2"	216 to 275 (159 to 202)	
2"	255 to 333 (188 to 246)	

(4) Jubilee Clip (Low Pressure and Suction)

Nominal cord	Diameter		Recommended torque		Working pressure range	
	inches	mm	N-m	ft-lbs	kg/cm ²	psi
BS5315						
12	3/8" - 1/2"	9.5 - 12	3.4	2.5	56.0	796
16	1/2" - 5/8"	11 - 16	3.4	2.5	56.0	796
20	1/2" - 3/4"	13 - 20	3.4	2.5	56.0	796
22	5/8" - 7/8"	16 - 22	4.5	3.3	56.0	796
25	3/4" - 1"	18 - 25	4.5	3.3	56.0	796
30	7/8" - 1 1/8"	22 - 30	4.5	3.3	56.0	796
35	1" - 1 3/8"	25 - 35	4.5	3.3	56.0	796
40	1 1/8" - 1 5/8"	27 - 40	4.5	3.3	35.0	498
50	1 1/4" - 1 7/8"	35 - 50	4.5	3.3	35.0	498
55	1 1/2" - 2 1/8"	40 - 55	5.9	4.3	21.0	299
60	1 3/4" - 2 3/8"	45 - 60	5.9	4.3	21.0	299
70	2" - 2 3/4"	55 - 70	5.9	4.3	16.8	239
80	2 3/8" - 3 1/8"	60 - 80	5.9	4.3	16.8	239
90	2 3/4" - 3 1/2"	70 - 90	6.8	5.0	16.8	239
100	3 1/4" - 4"	85 - 100	6.8	5.0	16.8	239
120	3 3/4" - 4 1/2"	90 - 120	6.8	5.0	10.5	149
140	4 1/8" - 5 1/2"	110 - 140	6.8	5.0	10.5	149
150	5" - 5 3/4"	130 - 150	6.8	5.0	10.5	149
165	5 1/4" - 6 1/2"	135 - 165	6.8	5.0	9.8	139
190	6 1/4" - 7 1/2"	160 - 190	6.8	5.0	9.8	139
215	7 1/4" - 8 1/2"	185 - 215	7.6	5.6	9.0	128
240	8 1/4" - 9 1/2"	205 - 240	7.6	5.6	9.0	128
270	9 1/4" - 10 1/2"	235 - 270	7.6	5.6	9.0	128
290	10 1/4" - 11 1/2"	255 - 290	7.6	5.6	9.0	128
320	11 1/4" - 12 1/2"	285 - 320	7.6	5.6	9.0	128

3. GENERAL WORK STANDARD

3.2 STANDARD PARTS

3.2.1 BOLT

Size and kind of bolt can be identified as shown below.

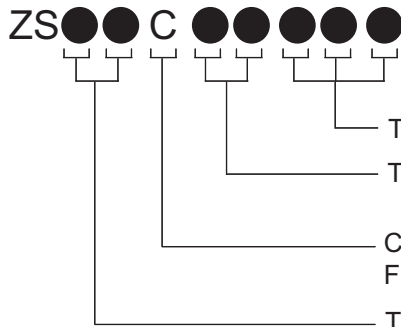

This part indicates the nominal bolt length. (L)

This part indicates the nominal size of bolt. (D)

C indicates coarse thread.

F indicates fine thread.

This part indicates the strength and type of the bolts.

In case of 11 or 16, it indicates 4T class.

In case of 12 or 17, it indicates 7T class.

In case of 13 or 18, it indicates 10T class.

In case of 23, it indicates Hexagon socket set screw.

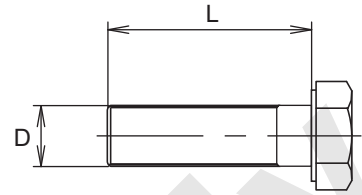

4.8 (4T)	7T	10.9 (10T)
ZS11F	ZS12F	ZS13F
ZS16F	ZS17F	ZS18F
ZS11C	ZS12C	ZS13C
ZS16C	ZS17C	ZS18C

3.2.2 O-RING

Size and kind of O-Ring are identified as shown below.

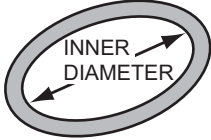
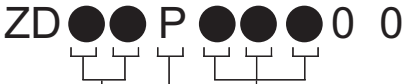

It indicate inner dia. (mm)

This part indicate the thickness of the O-ring.
P is for dynamic purpose.
G is for stationary purpose.

It indicates the type of rubber.
For practical use, these are identified
as color dot on O-ring, blue, red, green, or yellow.

- In case of 11, blue one dot and is Hs70.
- In case of 12, blue two dots and is Hs90.

Color dot also indicates as follows.

- Blue and red are both of nitrile rubber.
Blue is for use within range of -25°C to 120°C.
- Red is for gasoline proof type and normally not used.
- Green is of fluorine rubber and is ranged from -15°C to 200°C.

One blue dot	ZD11	Nitrile rubber	Hs70
Two blue dots	ZD12	Nitrile rubber	Hs90
One red dot		Nitrile rubber	Hs70
One yellow dot		Styrol rubber	Hs70
One green dot		Fluorine rubber	Hs70

Reference Only

3. GENERAL WORK STANDARD

3.2.3 BACK-UP RING

Size and kind of back-up ring are identified as shown below.

ZD ●● P ●●● 0 0

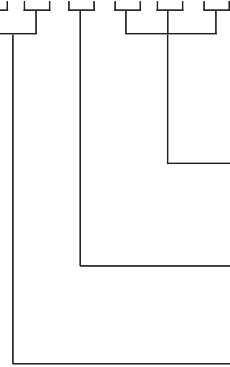

This part indicates the inner diameter (mm) of the back-up rings.

This part indicates the width of the back-up rings.

This part indicates the shape of the back-up rings.

The numeric 75 indicates "ENDLESS".
The numeric 85 indicates "BIAS CUT".
The numeric 95 indicates "SPIRAL".

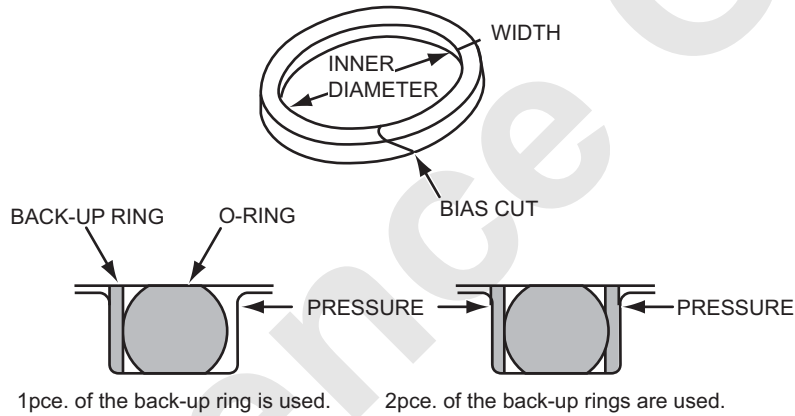

3.2.4 BITE TYPE FITTING

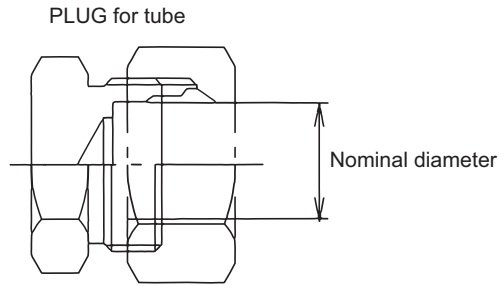

Nominal Diameter	Made by IHARA KOHATSU (ZF)	Made by NIHON AMC (ZA)
10	ZF83H10000	ZA82P10000
15	ZF83H15000	ZA82P15000
18	ZF83H18000	ZA82P18000
22	ZF83H22000	ZA82P22000
28	—	ZA82P28000
35	—	ZA82P35000

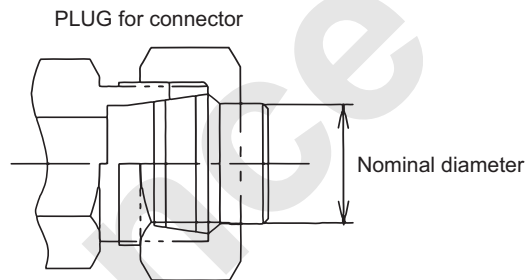

Nominal Diameter	Made by IHARA KOHATSU (ZF)	Made by NIHON AMC (ZA)
10	ZF83P10000	ZA83P10000
15	ZF83P15000	ZA83P15000
18	ZF83P18000	ZA83P18000
22	ZF83P22000	ZA83P22000
28	ZF83P28000	ZA83P28000
35	—	ZA83P35000

3. GENERAL WORK STANDARD

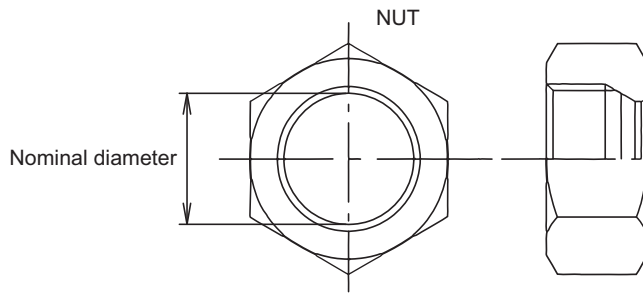

Nominal Diameter	Made by IHARA KOHATSU (ZF)	Made by NIHON AMC (ZA)
10	ZF93N10000	ZA93N10000
15	ZF93N15000	ZA93N15000
18	ZF93N18000	ZA93N18000
22	ZF93N22000	ZA93N22000
28	—	ZA93N28000
35	ZF93N35000	ZA93N35000

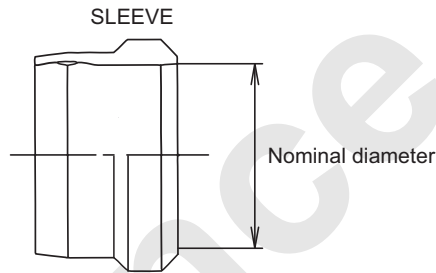

Nominal Diameter	Made by IHARA KOHATSU (ZF)	Made by NIHON AMC (ZA)
10	ZF93S10000	ZA93S10000
15	ZF93S15000	ZA93S15000
18	ZF93S18000	ZA93S18000
22	ZF93S22000	ZA93S22000
28	ZF93S28000	ZA93S28000
35	ZF93S35000	ZA93S35000

Tightening torque ZF Type

Nominal Diameter	10	15	18	22	28	35
Tightening Torque N-m (ft-lbs)	49 to 69 (36 to 50)	98 to 138 (73 to 101)	157 to 197 (116 to 144)	196 to 236 (146 to 174)	246 to 304 (180 to 220)	314 to 372 (233 to 273)

Tightening torque ZA Type

Nominal Diameter	10	15	18	22	28	35
Tightening Torque N-m (ft-lbs)	39 to 49 (28 to 36)	108 to 128 (80 to 94)	128 to 166 (94 to 122)	197 to 235 (146 to 174)	246 to 304 (180 to 220)	385 to 443 (291 to 319)

3.3 CONVERSION TABLE

3.3.1 UNIT CONVERSION

[Remarks] Figures in () show number of zero down a decimal point

Example : 0.(2)1 = 0.001

1. Length

Unit	mm	cm	m	km	in	ft	yd	mile
mm	1	0.1	0.001	0.000001	0.03937	0.0032808	0.0010936	0.(6)6214
cm	10	1	0.01	0.00001	0.3937	0.032808	0.010936	0.(5)6214
m	1000	100	1	0.001	39.37	3.28083	1.0936	0.(3)6214
km	...	100000	1000	1	39370	3280.83	1093.61	0.62137
in	25.4	2.540	0.0254	0.(4)254	1	0.0833	0.02778	0.(4)1578
ft	304.8	30.48	0.3048	0.(3)3048	12	1	0.3333	0.(3)1894
yd	914.4	91.44	0.9144	0.(3)9144	36	3	1	0.(3)5682
mile	1609347.0	160934.70	1609.35	1.60935	63360	5280	1760	1

2. Capacity

Unit	cm ³	m ³	ltr.	kltr.	in ³	ft ³	yd ³	gal
cm ³	1	0.(5)1	0.001	0.(5)1	0.06102	0.(4)3531	0.(5)1308	0.(3)2642
m ³	1000000	1	1000	1	61020	35.31	1.308	264.2
ltr.	1000	0.001	1	0.001	61.02	0.03531	0.001308	0.2642
kltr.	1000000	1	1000	1	61020	35.31	1.308	264.2
in ³	16.39	0.(4)1639	0.01639	0.(4)1639	1	0.(3)5787	0.(4)2143	0.004329
ft ³	28320	0.02832	28.32	0.02832	1728	1	0.03704	7.48055
yd ³	764500	0.7645	764.5	0.7645	46660	27	1	201.974
gal (USA)	3785	0.003785	3.785	0.003785	231	0.1337	0.004951	1

3. Weight

Unit	kg	oz	lb	(2000 lbs) nt	(2240 lbs) gt	mt
kg	1	35.2740	2.20462	0.001102	0.(3)9842	0.001
oz	0.02835	1	0.06250	0.(4)3125	0.(4)2790	0.(4)2835
lb	0.45359	16	1	0.00050	0.(3)4460	0.(3)4536
nt	907.185	32000	2000	1	0.89286	0.90719
gt	1016.05	35840	2240	1.12	1	1.01605
mt	1000	35274	2204.6	1.10231	0.98421	1

[Remakes] mt : ton (Metric) nt : ton (U.s.unit) gt : (British Unit)

3. GENERAL WORK STANDARD

3.3.2 MILLIMETER : INCH CONVERSION TABLE

1. mm (Millimeter) → in (Inch)

1 mm to 99 mm										
mm	0	1	2	3	4	5	6	7	8	9
	in									
0	0.0000	0.0394	0.0787	0.1181	0.1575	0.1969	0.2362	0.2756	0.3150	0.3543
10	0.3937	0.4331	0.4724	0.5118	0.5512	0.5906	0.6299	0.6693	0.7087	0.7480
20	0.7874	0.8268	0.8661	0.9055	0.9449	0.9843	1.0236	1.0630	1.1024	1.1417
30	1.1811	1.2205	1.2598	1.2992	1.3386	1.3780	1.4173	1.4567	1.4961	1.5354
40	1.5748	1.6142	1.6535	1.6929	1.7323	1.7717	1.8110	1.8504	1.8898	1.9291
50	1.9685	2.0079	2.0472	2.0866	2.1260	2.1654	2.2047	2.2441	2.2835	2.3228
60	2.3622	2.4016	2.4409	2.4803	2.5197	2.5591	2.5984	2.6378	2.6772	2.7165
70	2.7559	2.7953	2.8346	2.8740	2.9134	2.9528	2.9921	3.0315	3.0709	3.1102
80	3.1496	3.1890	3.2283	3.2677	3.3071	3.3465	3.3858	3.4252	3.4646	3.5039
90	3.5433	3.5827	3.6220	3.6614	3.7008	3.7402	3.7795	3.8189	3.8583	3.8976

25.4 mm = 1 inch

2. in (Inch) → mm (Millimeter)

in	0	1	2	3	4	5	6	7	8	9
	mm									
0	0.000	25.400	50.800	76.200	101.600	127.000	152.400	177.800	203.200	228.600
1/64	0.397	25.797	51.197	76.597	101.997	127.397	152.797	178.197	203.597	228.997
1/32	0.794	26.194	51.594	76.994	102.394	127.794	153.194	178.594	203.994	229.394
1/16	1.588	26.988	52.388	77.788	103.188	128.588	153.988	179.388	204.788	230.188
3/32	2.381	27.781	53.181	78.581	103.981	129.381	154.781	180.181	205.581	230.981
1/8	3.175	28.575	53.975	79.375	104.775	130.175	155.575	180.975	206.375	231.775
5/32	3.969	29.369	54.769	80.169	105.569	130.969	156.369	181.769	207.169	232.569
3/16	4.763	30.163	55.563	80.963	106.363	131.763	157.163	182.563	207.963	233.363
7/32	5.556	30.956	56.356	81.756	107.156	132.556	157.956	183.356	208.756	234.156
1/4	6.350	31.750	57.150	82.550	107.950	133.350	158.750	184.150	209.550	234.950
9/32	7.144	32.544	57.944	83.344	108.744	134.144	159.544	184.944	210.344	235.744
5/16	7.938	33.338	58.738	84.138	109.538	134.938	160.338	185.738	211.138	236.538
11/32	8.731	34.131	59.531	84.931	110.331	135.731	161.131	186.531	211.931	237.331
3/8	9.525	34.925	60.325	85.725	111.125	136.525	161.925	187.325	212.725	238.125
13/32	10.319	35.719	61.119	86.519	111.919	137.319	162.719	188.119	213.519	238.919
7/16	11.113	36.513	61.913	87.313	112.713	138.113	163.513	188.913	214.313	239.713
15/32	11.906	37.306	62.706	88.106	113.506	138.906	164.306	189.706	215.106	240.506
1/2	12.700	38.100	63.500	88.900	114.300	139.700	165.100	190.500	215.900	241.300
17/32	13.494	38.894	64.294	89.694	115.094	140.494	165.894	191.294	216.694	242.094
9/16	14.288	39.688	65.088	90.488	115.888	141.288	166.688	192.088	217.488	242.888
19/32	15.081	40.481	65.881	91.281	116.681	142.081	167.481	192.881	218.281	243.681
5/8	15.875	41.275	66.675	92.075	117.475	142.875	168.275	193.675	219.075	244.475
21/32	16.669	42.069	67.469	92.869	118.269	143.669	169.069	194.469	219.869	245.269
11/16	17.463	42.863	68.263	93.663	119.063	144.463	169.863	195.263	220.663	246.063
23/32	18.256	43.656	69.056	94.456	119.856	145.256	170.656	196.056	221.456	246.856
3/4	19.050	44.450	69.850	95.250	120.650	146.050	171.450	196.850	222.250	247.650
25/32	19.844	45.244	70.644	96.044	121.444	146.844	172.244	197.644	223.044	248.444
13/16	20.638	46.038	71.438	96.838	122.238	147.638	173.038	198.438	223.838	249.238
27/32	21.431	46.831	72.231	97.631	123.031	148.431	173.831	199.231	224.631	250.031
7/8	22.225	47.625	73.025	98.425	123.825	149.225	174.625	200.025	225.425	250.825
29/32	23.019	48.419	73.819	99.219	124.619	150.019	175.419	200.819	226.219	251.619
15/16	23.813	49.213	74.613	100.013	125.413	150.813	176.213	201.613	227.013	252.413
31/32	24.606	50.006	75.406	100.806	126.206	151.606	177.006	202.406	227.806	253.206

3. GENERAL WORK STANDARD

3.3.3 METER AND FOOT CONVERSION TABLE

Foot	Meter
5	1.52
10	3.05
15	4.57
20	6.10
25	7.62
30	9.14
35	10.67
40	12.19
45	13.72
50	15.24
55	16.76
60	18.29
65	19.81
70	21.34
75	22.86
80	24.38
85	25.91
90	27.43
95	28.96
100	30.48
105	32.00
110	33.53
115	35.05
120	36.58
125	38.10
130	39.62
135	41.15
140	42.67
145	44.20
150	45.72
155	47.24
160	48.77
165	50.29
170	51.82

Foot	Meter
175	53.34
180	54.86
185	56.39
190	57.91
195	59.44
200	60.96
205	62.48
210	64.01
215	65.53
220	67.06
225	68.58
230	70.10
235	71.63
240	73.15
245	74.68
250	76.20
255	77.72
260	79.25
265	80.77
270	82.30
275	83.82
280	85.34
285	86.87
290	88.39
295	89.92
300	91.44
305	92.96
310	94.49
315	96.01
320	97.54
325	99.06
330	100.58
335	102.11
340	103.63

Foot	Meter
345	105.12
350	106.68
355	108.20
360	109.73
365	111.25
370	112.78
375	114.30
380	115.82
385	117.35
390	118.87
395	120.40
400	121.92
405	123.44
410	124.97
415	126.49
420	128.02
425	129.54
430	131.06
435	132.59
440	134.11
445	135.64
450	137.16
455	138.68
460	140.21
465	141.73
470	143.26
475	144.78
480	146.30
485	147.83
490	149.35
495	150.88
500	152.40

1 foot = 0.3048 meter

3.3.4 GRADE CONVERSION TABLE

Degree (°)	%
1	1.8
2	3.5
3	5.2
4	7.0
5	8.8
6	10.5
7	12.3
8	14.1
9	15.8
10	17.6
11	19.4
12	21.3
13	23.1
14	24.9
15	26.8

Degree (°)	%
16	28.7
17	30.6
18	32.5
19	34.4
20	36.4
21	38.4
22	40.4
23	42.5
24	44.5
25	46.6
26	48.8
27	51.0
28	53.2
29	55.4
30	57.7

Degree (°)	%
31	60.1
32	62.5
33	64.9
34	67.5
35	70.0
36	72.7
37	75.4
38	78.1
39	81.0
40	83.9
41	86.9
42	90.0
43	93.3
44	96.6
45	100.0

3.3.5 UNIT WEIGHT TABLE

Material	Weight per Cub. Meter (t)
Lead	11.4
Copper	8.9
Steel	7.8
Cast iron	7.2
Aluminum	2.7
Concrete	2.3
Soil	2.0
Gravel	1.9

Material	Weight per Cub. Meter (t)
Sand	1.9
Coal cold	0.8
Coal powder	1.0
Coke	0.5
Oak	0.9
Cedar	0.4
Cypress	0.4
Paulownia	0.3

Note

Weight of wood is that of the dried.
Value shown in the table may well be taken for specific gravity.

3. GENERAL WORK STANDARD

3.3.6 SYSTEM INTERNATIONAL (SI) UNIT CONVERSION TABLE

No.	International System of Units (SI : System International Unit)			Conversion Formula CGS unit system to SI unit system
	Types	Unit symbols	Meaning	
1	Mass	kg	Kilogram	Mass (kg) = Weight (kgf) F = gravity
2	Force (Load)	N kN	Newton Kilonewton	1 (N) = 1 (kg) × 9.80 1 (kN) = 1 (N) ÷ 1000
3	Moment of force	N-m	-	1 (N-m) = 1 (N) × 1 (m)
4	Stress	N/mm ²	-	1 (N/mm ²) = 1 (N) ÷ 1 (mm ²)
5	Pressure (hydraulic pressure, pneumatic pressure) ground pressure	Pa kPa MPa	Pascal Kilopascal Megapascal	1 (Pa) = 1 (N/mm ²) 1 (kPa) = 1 (Pa) ÷ 1000 1 (MPa) = 1 (kPa) ÷ 1000
6	Horsepower (motive power)	kW	Kilowatt	1 (kW) = 1 (PS) ÷ 0.7355 PS = horsepower
7	Energy	J	Joule	1 (J) = 1 (N-m)

GRAVIMETRIC UNIT $\xleftrightarrow{\times}$ SI UNIT

kgf	9.807	N
lbf	4.448	N
kgf-cm	0.0981	N-m
lbf-ft	1.356	N-m
lbt-in	0.113	N-m
kgf/cm ³	0.0981	MPa
atm	0.1013	MPa
lbf/in ²	0.0069	MPa
kgf/cm ³	98.1	kPa
atm	101.3	kPa
lbt/in ²	6.9	kPa
mm Hg	133.3	Pa

GRAVIMETRIC UNIT $\xleftrightarrow{\times}$ SI UNIT

in Hg	3386	Pa
kgf-m/s	0.00981	kW
lbf-ft/s	0.00136	kW
PS	0.7355	kW
HP	0.746	kW
kgf-m	9.807	J
kcal	4186	J
kgf-s/cm ³	98067	Pa-s
cP	0.001	Pa-s
P	0.1	Pa-s
cSt	1 × 10 ⁻⁶	m ² /s
cSt	1	mm ² /s
St	0.0001	m ² /s
atm-cc/s	0.1013	Pa-m ³ /s

4. POWER TRAIN

Reference Only

Reference Only

4.1 INTRODUCTION

This crane is a full hydraulic crawler crane. The engine drives one set of the 2 section plunger type main pump and one plunger type swing pump and 2 section gear pump connected to the power divider and 2 section gear pump connected to swing pump through the power divider.

The 2 section main pump are variable displacement type pump and provides the power to left and right propel motors, boom hoist motor, each of front and rear hoist motors through the two control valves.

Furthermore, by adding special control valve it provides power to the third hoist motor (option).

Each of the front, the rear and the third motor drives the drum shaft through the respective reduction unit and raise, lower or stop the respective drum through the drum built in clutch. The boom hoist motor drive the boom hoist drum through the respective reduction unit to raise, lower or stop the boom.

The left or right propel motor drives each drive tumbler through the respective reduction unit to propel the machine.

One other plunger pump provides the power to the swing motor. The swing motor swings the upper machinery through the reduction unit.

Inner one of the two gear pumps connected to the swing pump sends pressured oil to the control line and outer one sends the pressured oil to the gantry hoist cylinder, crawler ext/ret cylinder and tagline (option). The 2 section gear pump (option) connected to the power divider provides the pressured oil to free fall brake cooling line of the front and rear drum.

4. POWER TRAIN

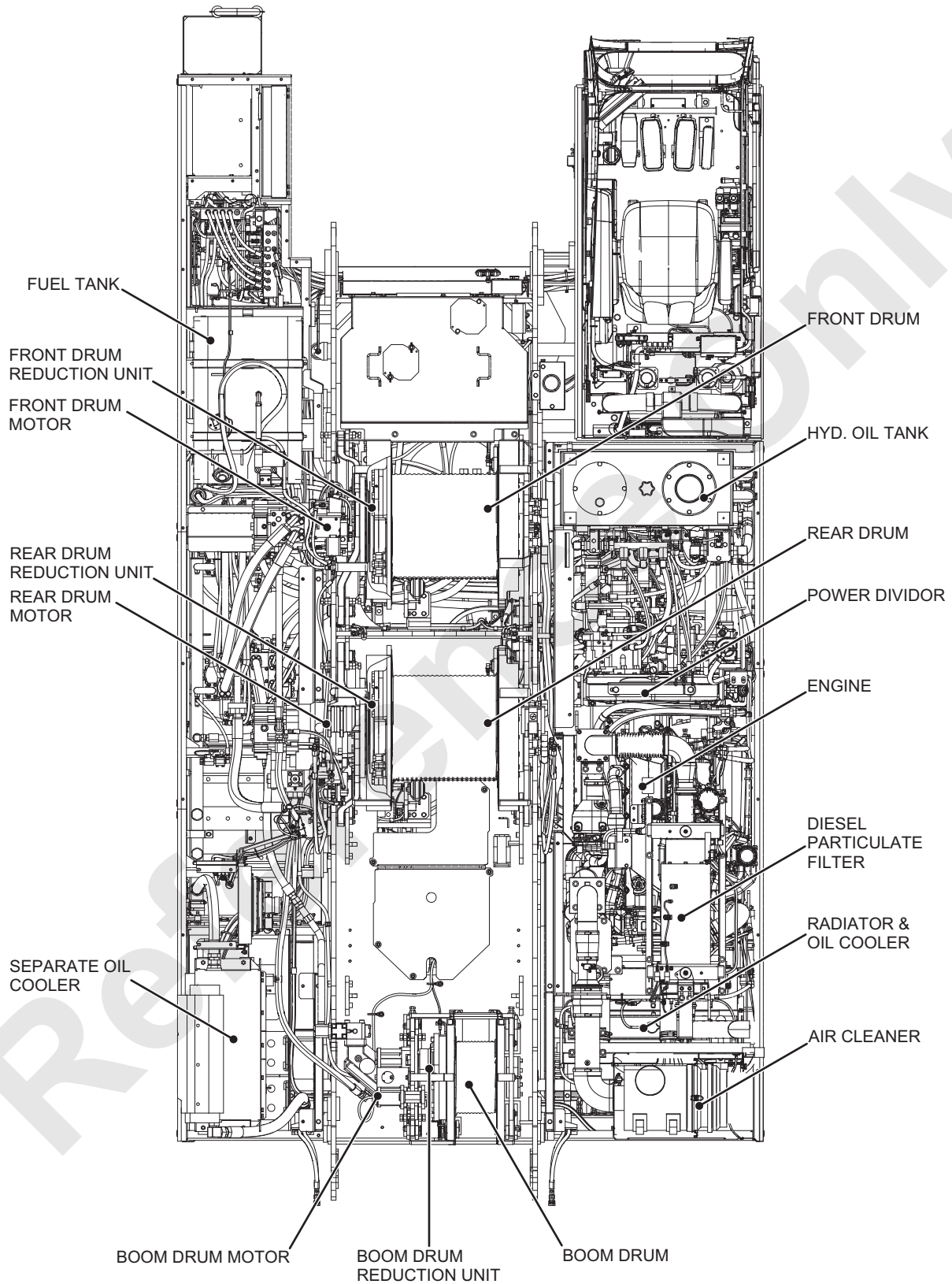

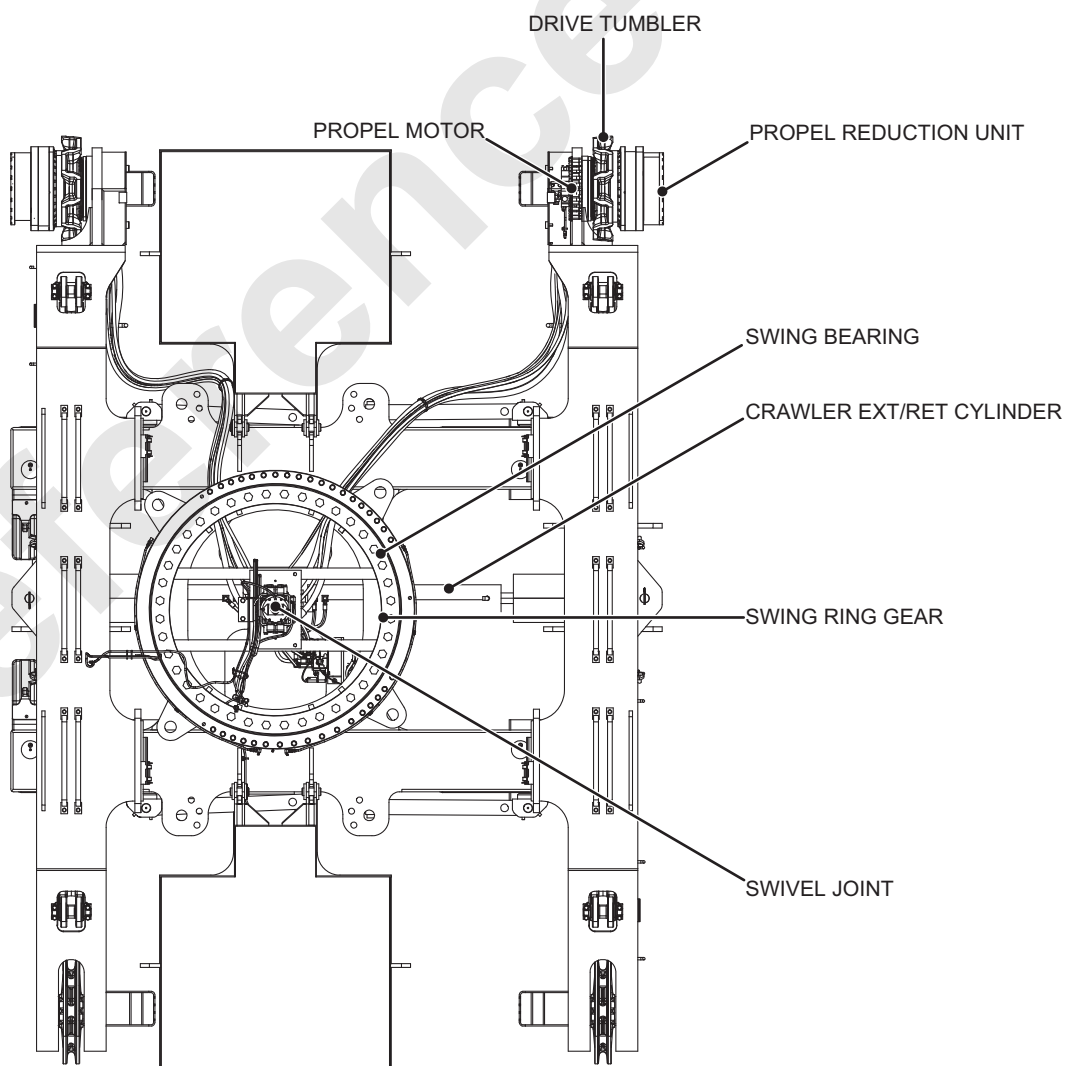
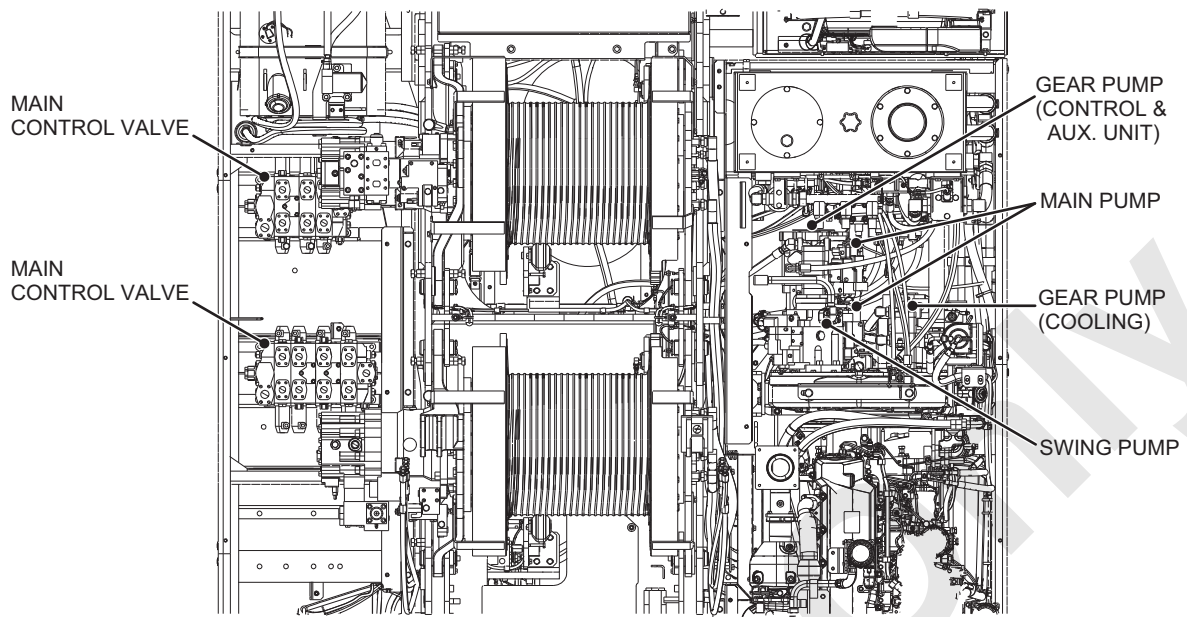

4. POWER TRAIN

4.2 ENGINE

4.2.1 INTRODUCTION

This chapter explains how to remove and re-install the engine.

Refer to the manual provided by the engine manufacturer for maintenance and repair details.

4.2.2 REMOVAL

Proceed as follows when removing the engine from the machine.

CAUTION

Remove the pump drive assembly with the engine. It is dangerous to drain oil, water or to replace filter right after engine stop due to high temperature. Wait until temperature comes down. On the other hand, warm up oil to appropriate temperature (approx. 20 to 40° C) for oil drain if oil is cooled down.

1. Lower the boom on the ground and secure the upper spreader to the boom base with pins. Set the gantry to the propel configuration.
2. Take out the ground cable first in the battery.
3. Remove the cover of the diesel particulate filter and remove the flange bolts (4 pcs.) of the exhaust tube.
4. Remove the air inlet hose from the engine.
5. The inter-cooler piping is secured on the guard beam. Remove these bolts.
6. Remove the electric wiring connectors which are connected to the diesel particulate filter and air cleaner.
7. Remove the guard and the engine hood assy. required to remove the engine and pump drive assy.
8. Drain the hydraulic oil, engine oil and cooling water.
9. Remove the fan shroud from the radiator.
10. Remove the hyd. pump piping and label them. Put the cover on all the port and hose to prevent dirty material getting in.
11. Label engine cooling piping, inter-cooler, fuel piping, and electric wiring and remove them. Put the caps on the cooling water piping, intercooler piping and fuel piping to prevent foreign material getting in.
12. Check that all the electric wiring, mechanical connection and fuel piping are disconnected and there would be no interference for removing the engine.

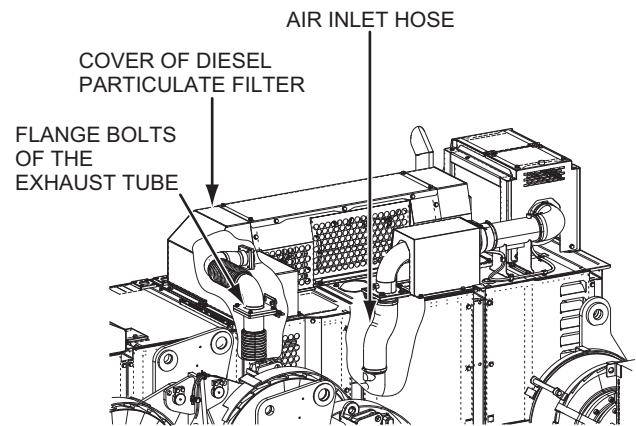

Refer

4. POWER TRAIN

13. Install the appropriate capacity of lifting gear to the engine.
(The engine has three lifting hooks.)
14. Remove the bolts and washers from the rubber mounts on the engine and the power divider.
15. Lift up the engine and pump drive assy. as one unit slowly and take out from the machine.
Weight is approx. 1,250 kg (2,756 lbs).

CAUTION

Take necessary action to prevent overturning of the engine.

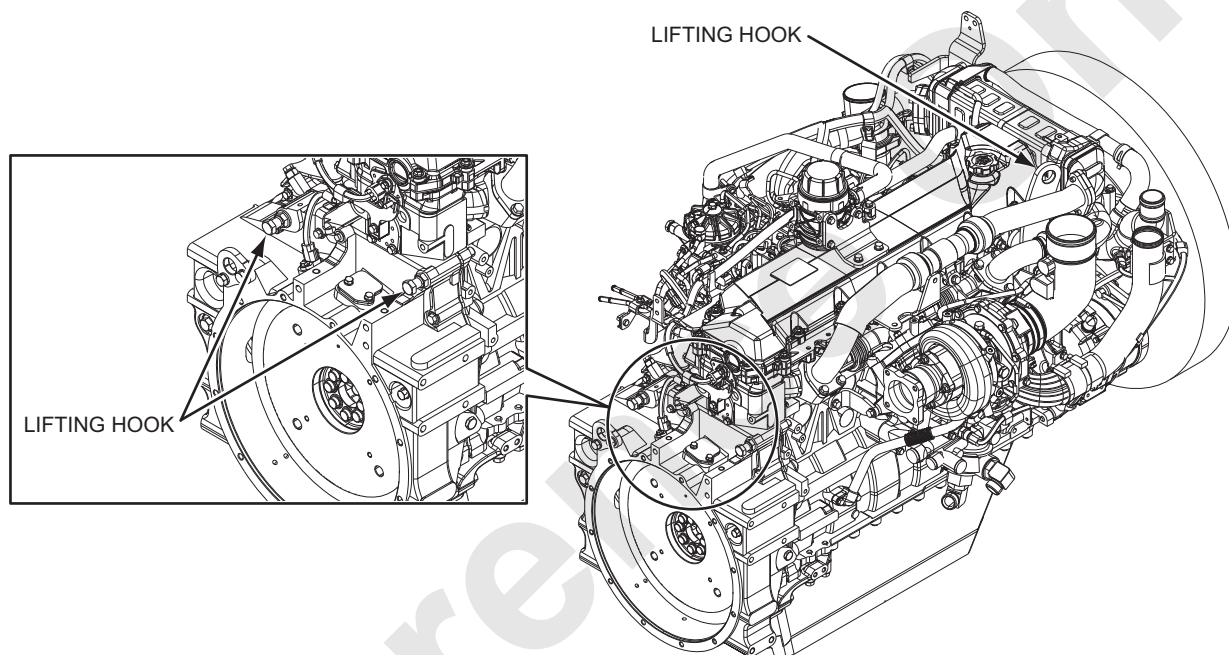

16. Inspect the rubber mount and replace them if required.

This page is blank for editing convenience.

Reference Only

4. POWER TRAIN

4.2.3 REPAIR AND MAINTENANCE

Regarding the repair and maintenance of the engine, refer to the manual provided by the manufacturer.

The engine manufacturer : HINO MOTORS, LTD.

The engine model : J08E-UV

4.2.4 INSTALLATION

Proceed as follows when installing the engine.

1. Check to make sure that no fuel lines, coolant water hoses, mechanical connection parts or other items are left to interfere with the installation.
2. If the rubber mounts were removed, replace them.
3. Using a enough capacity lifting gear, lift the engine and place it onto the mounting place.
4. Use LOCTITE #271 on the rubber mount holding bolts and tighten to the specified torque.
Front side : 504 to 616 N-m (372 to 454 lbs-ft)
Rear side : 360 to 440 N-m (266 to 324 lbs-ft)
5. Install the fan shroud. The clearance between the fan shroud and the fan should be even all around.
6. Connect all the electric wirings that were disconnected when the engine was removed.
7. Install all the fuel and cooling piping that were removed when the engine was removed.
8. Install the guard, engine hood assembly and connect the battery cable.



The battery generates flammable hydrogen gas. Never bring a flame close to the battery to prevent inflammation or explosion.
Do not place any metal objects such as tools on or around of the battery to prevent causing spark.
Ensure to properly use booster cables to prevent explosion sue to miss-use.

9. Install the air inter cooler hose that were removed when the engine was removed.
Install the exhaust tube and the diesel particulate filter cover.
10. Install all the hydraulic hoses to the hydraulic pumps.
11. Refill the engine with coolant water and engine oil to the required levels.
12. Remove the air from the fuel lines.

CAUTION

Before starting the engine, re-check all electrical, fuel, water and hydraulic connections as well as mechanical connections.

Be prepared to stop the engine immediately if something unusual develops.

Check that no person eel are around the engine before starting.

13. Start the engine and set it to low idle.
Check for water and fuel leaks, and any strange noises.

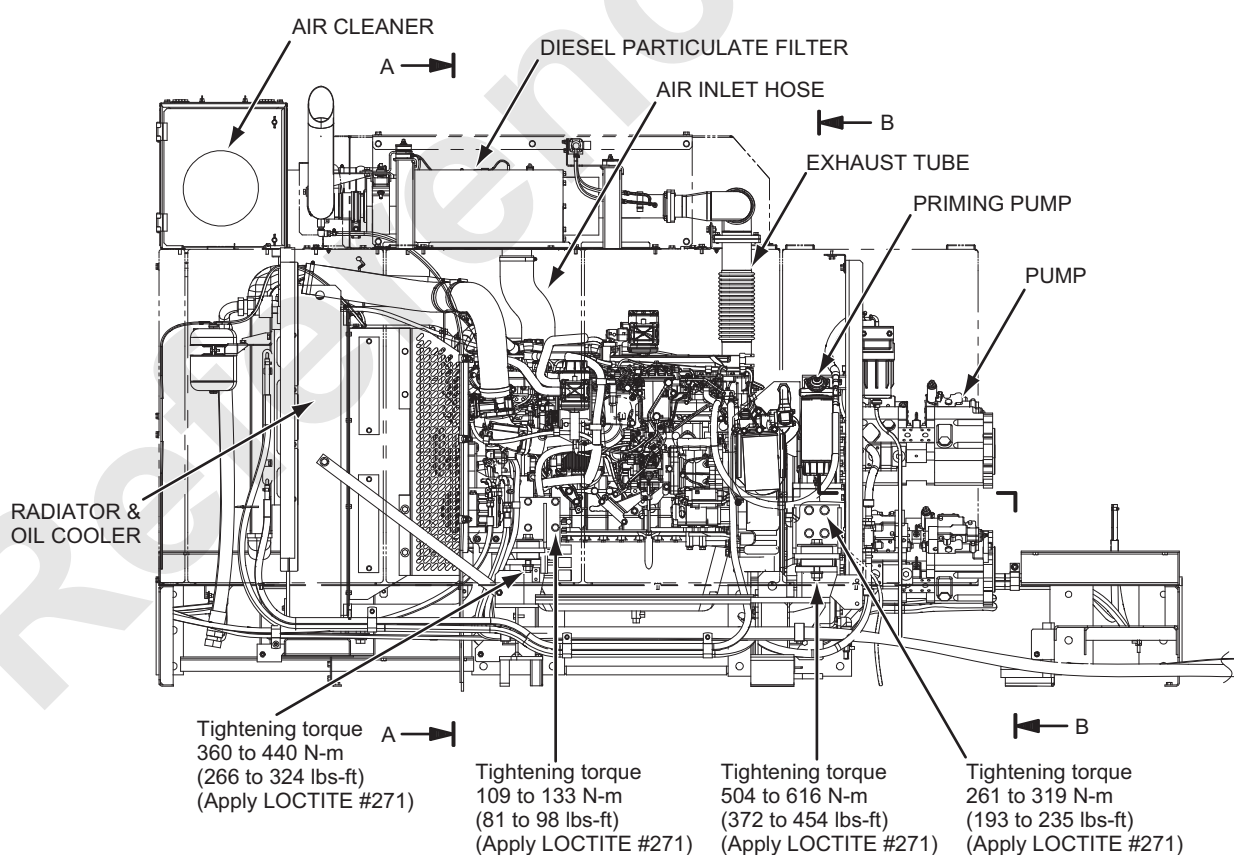

Tightening torque
109 to 133 N-m (81 to 98 lbs-ft)
(Apply LOCTITE #271)

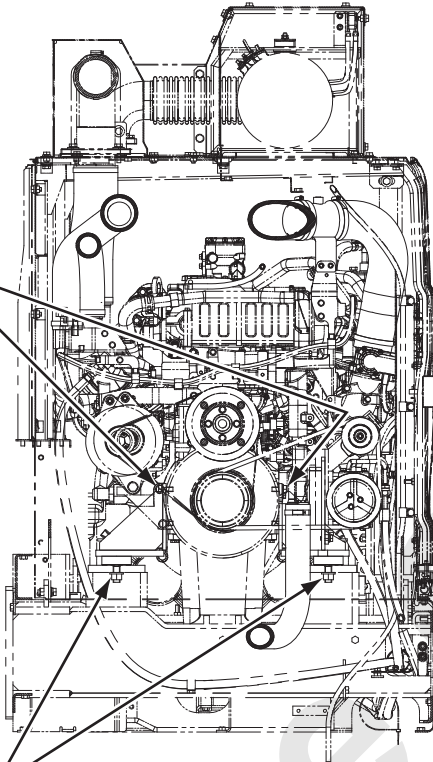

SECTION A-A

Tightening torque
360 to 440 N-m (266 to 324 lbs-ft)
(Apply LOCTITE #271)

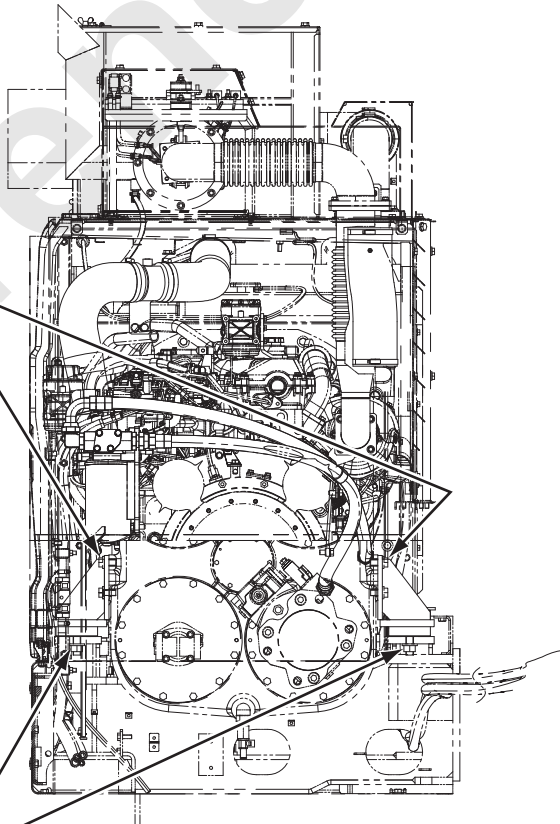

SECTION B-B

Tightening torque
261 to 319 N-m (193 to 235 lbs-ft)
(Apply LOCTITE #271)

Tightening torque
504 to 616 N-m (372 to 454 lbs-ft)
(Apply LOCTITE #271)

4.3 PUMP DRIVE ASSEMBLY

4.3.1 INTRODUCTION

This chapter explains how to remove, inspect, repair and re-install the pump drive assembly.

The pump drive assembly is mounted directly onto the front of the engine. It consists of a coupling, a power divider, main pumps, and 2 section gear pumps, swing pump and 2 section gear pumps which are connecting to the swing pump.

The power of the engine is transferred from a flywheel through the coupling to the input shaft and the helical gear of the power divider.

The power then is divided by 3 sets of helical gears (4 sets when option is selected) to the main pump shaft, swing pump shaft, cooling pump shaft.

(Closed with the flange when free less is selected.)

(See 4.3.2)

Reference

4. POWER TRAIN

4.3.2 REMOVAL

Proceed as follows when removing the pump drive assembly. (See next page)

CAUTION

Pump drive assembly should be removed from the engine according to the following procedure only after the engine has been removed from the machine as described in Section 4.2.

1. Drain the oil in the power divider through the port on the lower part of the power divider.
2. Remove the main pump and the swing pump (with gear pump) and the gear pump.

Main pump	143.0 kg (315.0 lbs)
Swing pump + 2 section gear pump	57.4 kg (126.5 lbs)
2 section gear pump (When "with free" is selected)	8.4 kg (18.5 lbs)

3. Using an enough capacity lifting device, attach the lift riggings to lifting screws provided on the power divider.
(screw holes : M16)
Remove the nuts (M10 fine) in the power divider stand and move the power divider slowly toward the back of the engine and remove the power divider after disconnecting the coupling.
Weight of the power divider :
Approx. 245 kg (540 lbs) (Approx. 260 kg (573 lbs) in case of four axle selected as option.)
4. The main part of this coupling will be removed with the power divider connected to its shaft.
Remove the remaining coupling bushing (engine side) or element.

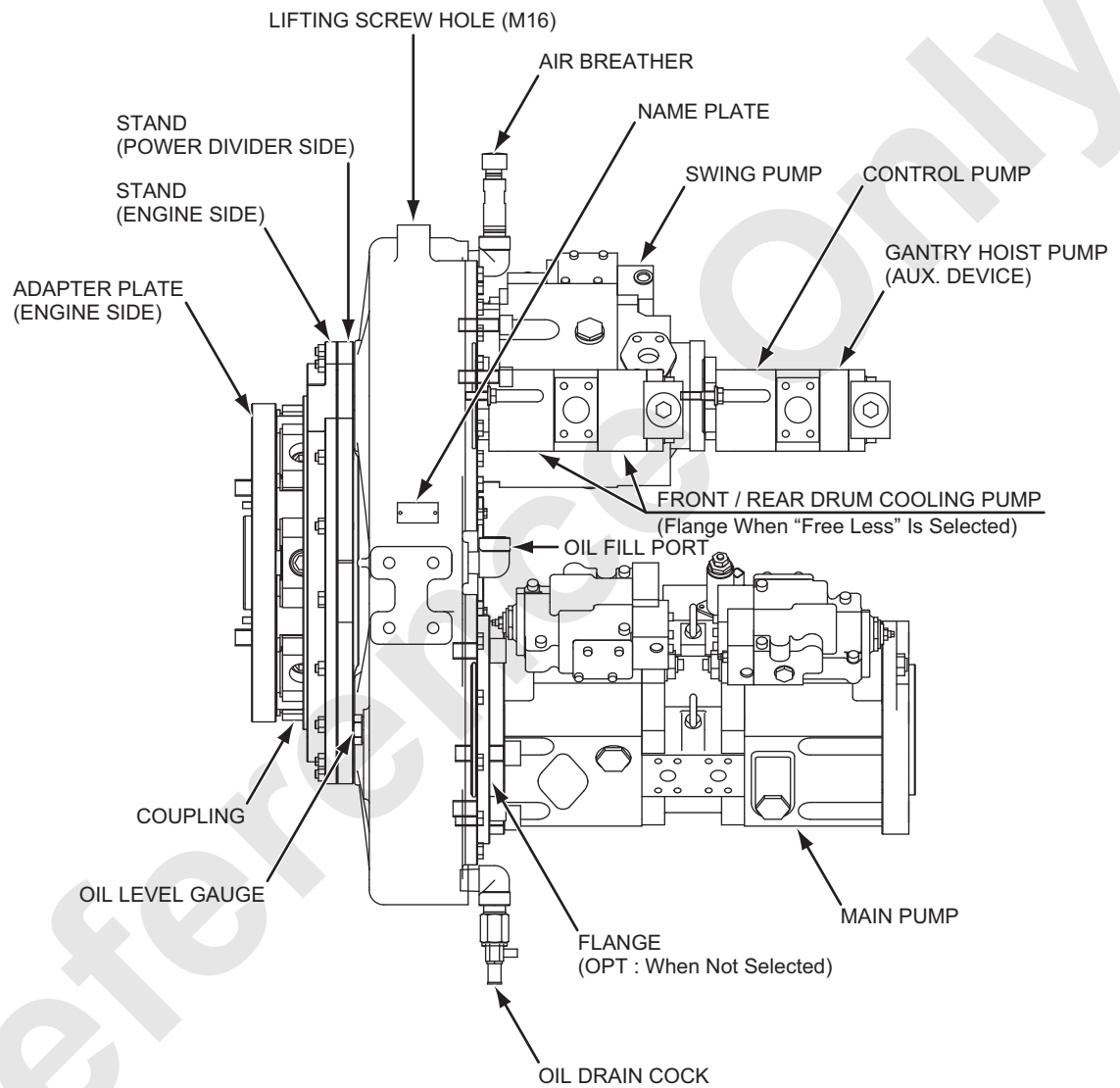

Fig.4-1 PUMP DRIVE (1/2)

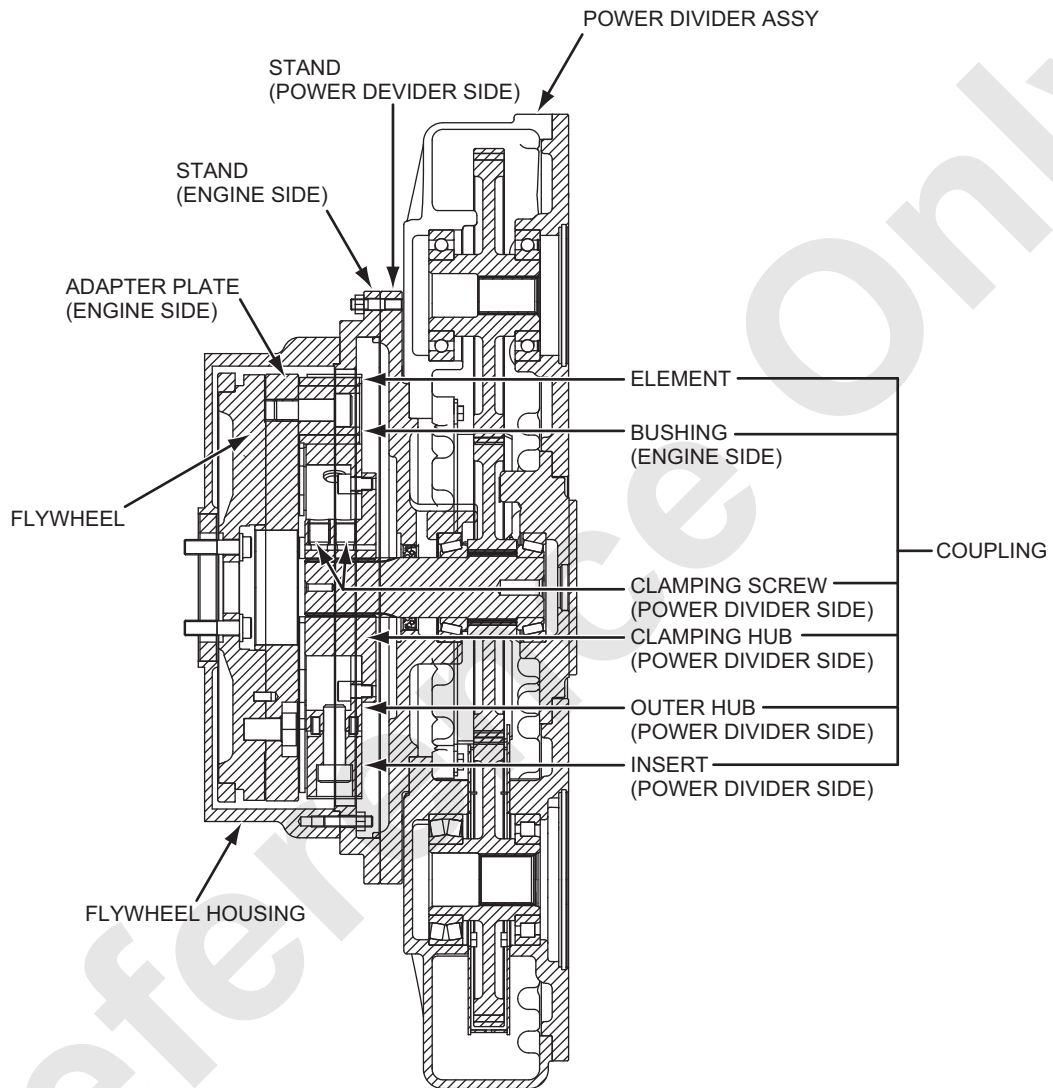

Fig.4-2 PUMP DRIVE (2/2)

4.3.3 DISASSEMBLING THE POWER DIVIDER

Proceed as follows when disassembling the power divider. (Refer to P.4-23 to 4-26 for corresponding numbers in the explanation below.)

1. Place the power divider on the block facing the flywheel side up.
2. Remove the cap screws (35) and remove the stand (2) using two pull out screw holes (M10) of the stand (2).
3. Remove the oil seal (29) and the outer lace of the taper roller bearing (28) from the stand (2) and then take out the shims (42), (43), and (44). In this time, keep the shim (42), (43), (44) as a set.
If required, remove the screw (36) and the plates (17).
4. Remove the shaft (3) and drive gear (4) as an assy.
If required, pull out the inner laces of both side taper roller bearings (28) and then pull out the drive gear (4).
5. Pull out the outer lace of the taper roller bearing (28) from the housing (1).
If required, remove the screws (36) and the plate (21).
6. Place the power divider on the block facing the pump side up.
7. Remove the cap screws (35) and the support (8) using two pull out screw holes (M10) of the support (8).
8. Remove the cap screws (35) and the plate (14).
9. Remove the cap screws (35) and the support (9) using two pull out screw holes (M10) of the support (9).
If required, remove the cap screws (34) and the plate (16).
10. Remove the gear (5) and both side bearings (22), (23) if required.
11. Remove the cap screw (34) and the plate (13).
12. Remove the cap screws (35) and remove the support (10) using two pull out screw holes (M10) of the support (10).
If required, remove the screws (36) and the plate (18).
13. Remove the gear (6) and both side bearings (24), (25).

4. POWER TRAIN

14. If required, remove the screws (36) and the plate (17).
15. Remove the cap screws (35) and the support (11) using two pull out screw holes (M10) of the support (11).
If required, remove the screws (36) and the plate (19).
16. Remove the gear (7) and if required, remove both side bearing (26), (27).
17. If required, remove the screws (36) and the plate (20).
18. If required, remove the cap screws (34) and plate (15).

4.3.4 CHECK AND REPAIR OF THE POWER DIVIDER

Check all parts prior to reassembling the power divider. All questionable parts should be replaced to maximize the re-assembled power divider's service life and to avoid further break downs.

Checking should proceed in the following order.

1. Clean all the parts with fresh cleaning oil and blow them dry.
2. Check bearing balls, rollers, inner and outer races to see that they are free of pitching and scratches. Replace any defective ones.
3. Bearings with no pitching or scratches should be lightly lubricated, but replace any bearings that develop rattles due to excessive clearances toward the shaft or toward the external side should be replaced.
4. Check the bearings' outer and inner races. Replace any that show indications of slipping and/or rolling.
5. Check the teeth of all the gears and replace any that show pitching, scratch, signs of friction wear, peeling or cracking.
6. Check the shafts and replace any with signs of cracking, deformation, wear at contact surfaces or bearing slippage.
7. Check the splines of the shafts and gears. Replace or fix any that show cracking, signs of wear or impact damage.
8. Check the bearing casings and replace any that show slip wear or other deformations.
9. Check the gear casings and replace or fix any that show cracks, deformation or scratches.
10. All the O-rings and oil seals should be replaced with new ones.
11. Check cap screw threadings and screw hole threadings and replace or repair any that show signs of cross-threading and or stripping.
12. Take out the breather cap and clean in the pipe and check the orifice hole for clogging.

4. POWER TRAIN

4.3.5 ASSEMBLING THE POWER DIVIDER

Assembling the power divider is in reverse order of disassembling. Take extra care on the following points in assembling.

(Refer to P.4-23 to 4-26 for corresponding numbers in the explanation below.)

1. Apply clean oil on each part and then assemble. But ensure to remove any oil on the mating face of the housing (1), the stand (2) and the support (8), (9), (10), (11) and apply LOCTITE #515 evenly on these face and also apply LOCTITE #242 on the cap screws (35) and tighten them to torque 63 to 77 N-m (46.5 to 56.7 lbs-ft).
2. When assembling the shaft (3), the drive gear (4), the taper roller bearing (28) and the stand (2), adjust the clearance shown in P.4-25 to become 0 to 0.15 mm with the shim (42), (43), (44).
3. Install the stand (2) and the support (8), (9), (10), (11) to the housing (1) to make oil groove comes to the position as shown in P.4-23. (UP cast mark upward)
4. After assembly, check that the input shaft turns lightly by hand.

4.3.6 RE-INSTALLATION

Assemble the pump drive assy. as follows.

(Refer to P.4-27 for corresponding numbers in the explanation below.)

1. Apply grease on the spline area of the input shaft (1) and insert the clamping hub (2) to 65 mm point from the shaft end as shown in P.4-27 (the clamping hub touches lightly on spline step area). Apply LOCTITE #242 on the clamping screws (3) (LOCTITE not necessary with micro capsule coating) and tighten to 200 to 220 N-m (147.6 to 162.2 lbs-ft) torque.
In case of micro capsule coating, if tightened once, remove completely first and then apply LOCTITE #242.
Tighten alternately and for 3 sets or more, ensure to tighten evenly.
2. Apply LOCTITE #242 on the cap screws (16) and tighten outer hub (9) onto the clamping hub (2) with the tightening torque 85 to 94 N-m (62.7 to 69.3 lbs-ft) torque.
(LOCTITE not necessary with micro capsule coating)
In case of micro capsule coating, if tightened once, remove completely first and then apply LOCTITE #242. Install the spring pin (4) to the outer hub (10) and install the element (5), insert (6) in its order to the coupling.
3. Apply LOCTITE #242 on the cap screws (7) and tighten to 440 to 490 N-m (324.6 to 361.5 lbs-ft) torque. (LOCTITE not necessary with micro capsule coating) In case of micro capsule coating, if tightened once, remove completely first and then apply LOCTITE #242.
4. Install the spring pin (13) and the adapter (15) to the side face of the fly wheel (8).
Apply LOCTITE #242 on the cap screws (14) and tighten to 504 to 616 N-m (371.7 to 454.3 lbs-ft) torque.
5. Install the bushing (10) to the adapter plate (15) and apply LOCTITE #242 on the cap screws (11) and then tighten to 440 to 490 N-m (324.6 to 361.5 lbs-ft) torque.
(LOCTITE not necessary with micro capsule coating)
In case of micro capsule coating, if tightened once, remove completely first and then apply LOCTITE #242.

4. POWER TRAIN

6. Attach the appropriate capacity lifting gear to the power divider and insert the coupling side element of the power divider to the wheel side insert. Install the power divider to the stand (engine side) which is installed on the flange wheel housing.
7. Apply LOCTITE #242 to the nut (M10 fine thread) and tighten with 36.4 to 44.6 N-m (26.9 to 32.8 lbs-ft) torque.
8. Apply LOCTITE #242 to each cap screws and tighten the tandem type main pump with 279 to 341 N-m (205.8 to 251.5 lbs-ft) torque, swing pump with 145 to 177 N-m (107 to 130 lbs-ft) torque, the cooling pump with 22 to 28 N-m (16.2 to 20.6 lbs-ft) torque (flange when free less is selected).
9. Fill in the power divider with the specified gear oil #90 to the specified level (Red mark on the oil level gauge)
(Approx. 10.7 ltr., When option is selected, approx. 10.0 ltr.)
10. Install the power divider with engine attached to the machine referring to [4.2 ENGINE]
11. Start the engine and check for unusual noise or oil leak during low idling speed.

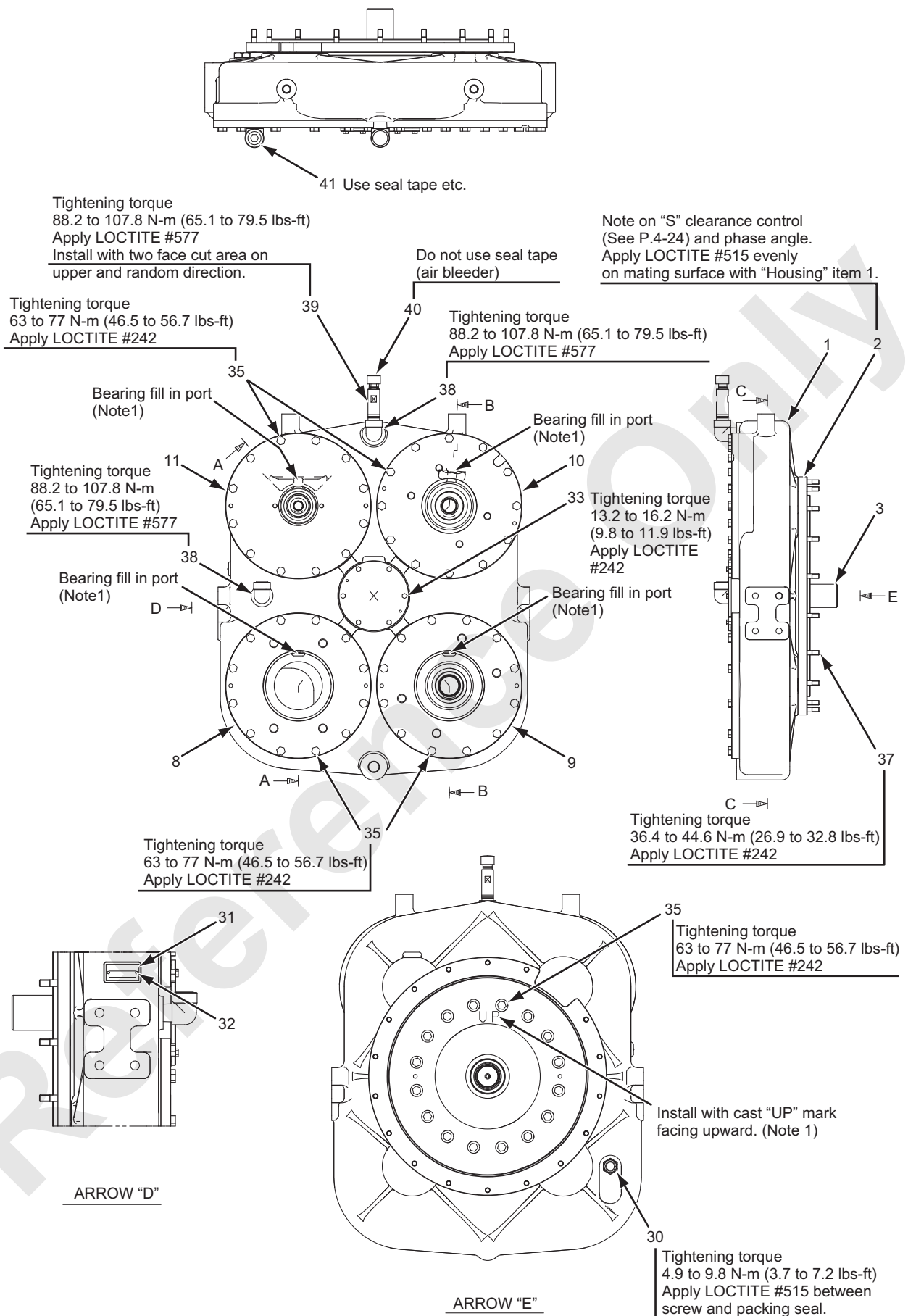

Fig.4-3 POWER DIVIDER (1/3)

4. POWER TRAIN

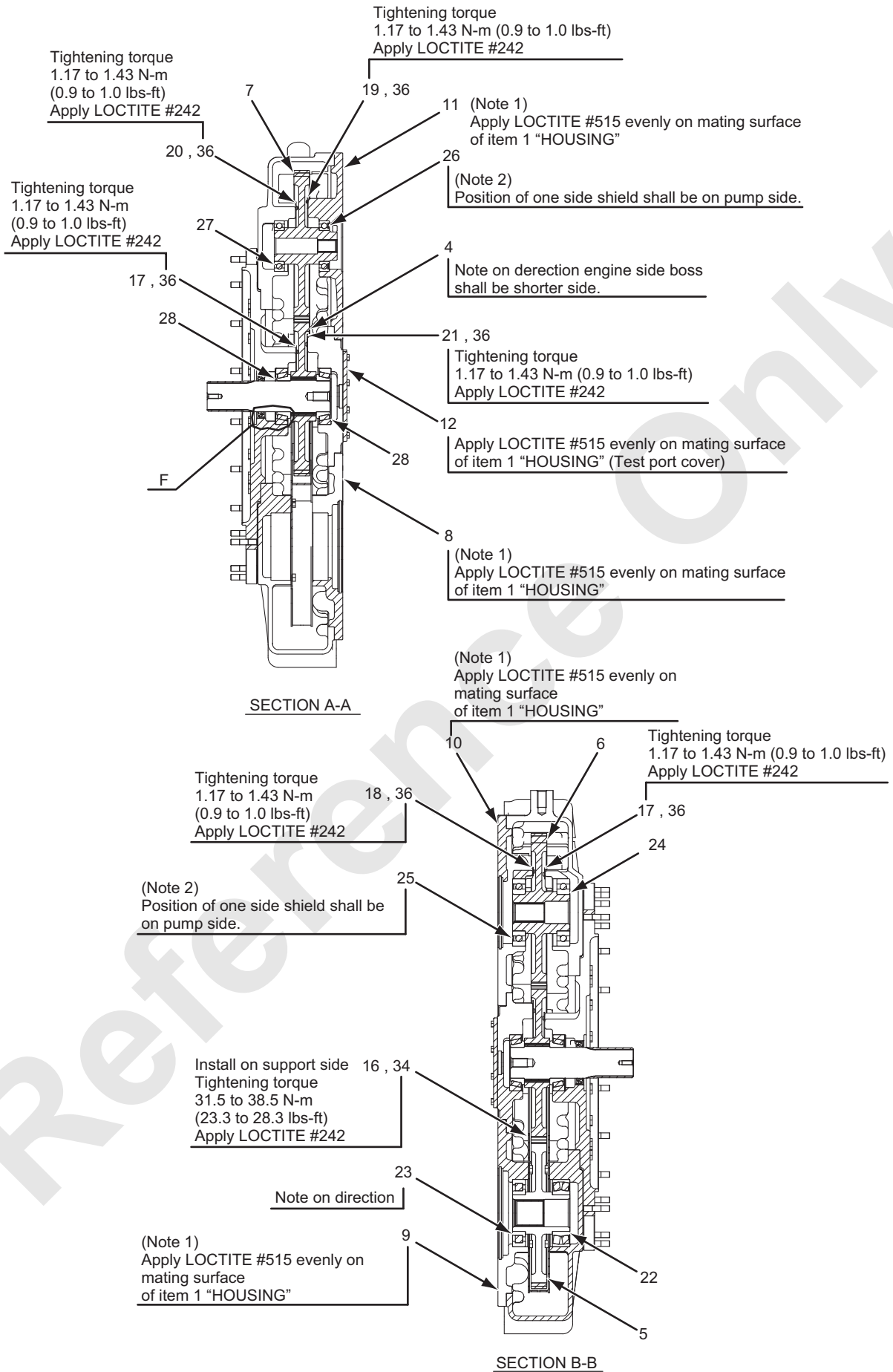
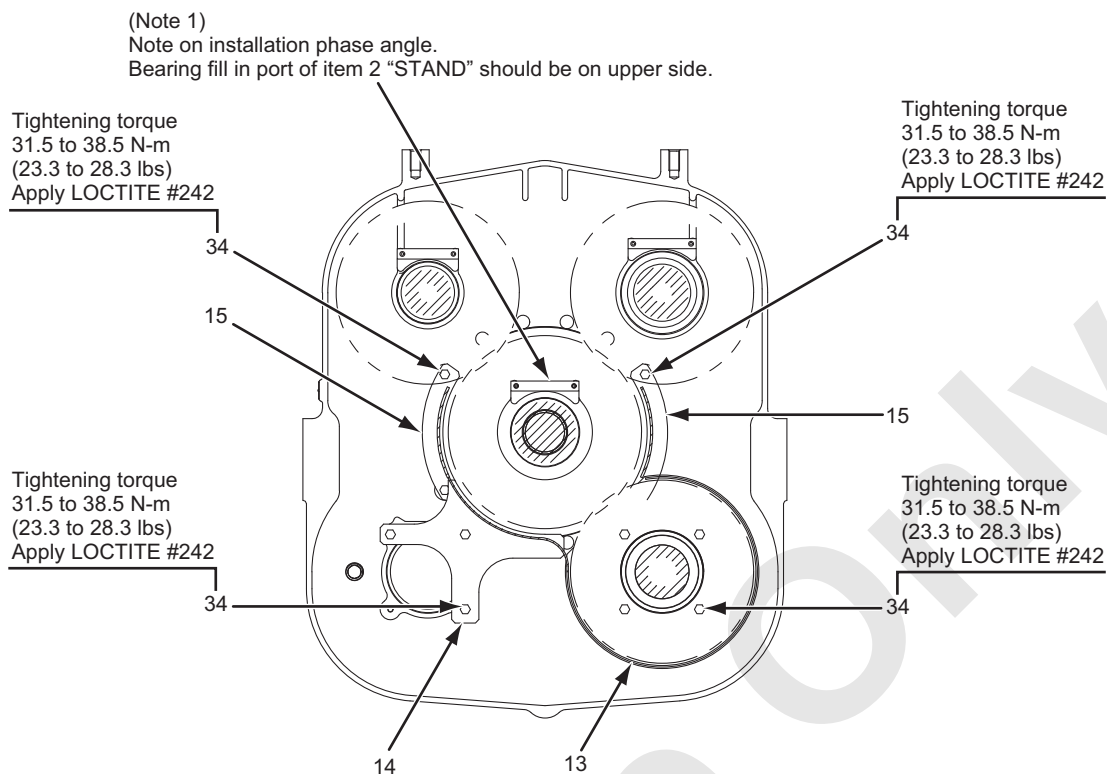
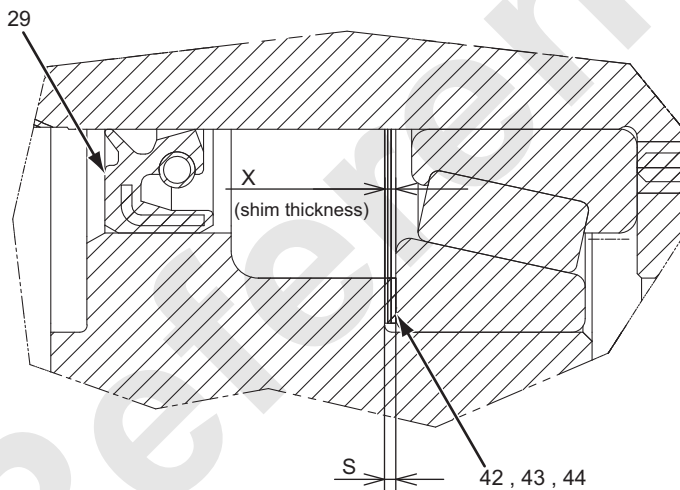

Fig.4-4 POWER DIVIDER (2/3)



SECTION C-C

Apply three bond #1211 or equivalent evenly on O.D. area.
Apply grease lightly on lip and dust lip area.
Ensure to use jig to install evenly.



Adjust clearance between item 28 "BEARING" outer race and item 2 "STAND" to become 0 to 0.15 mm with shim.

DETAIL OF "F"

SHIM (ITEM 42, 43, 44) ADJUSTING PROCEDURE

(1) Measure "a" and "b" dimensions as shown.

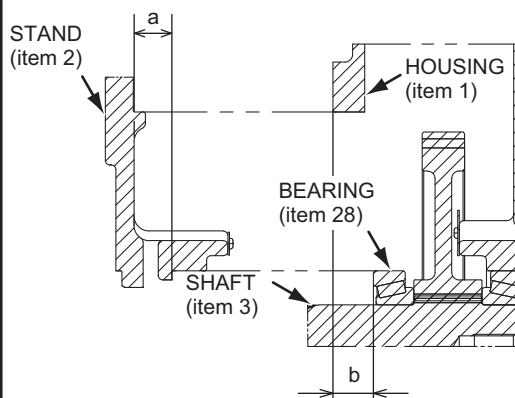

(2) Find difference between "a" and "b" dimensions and seek for required shim thickness to make clearance to become 0 to 0.15mm.

$$b - a = s$$

$$s - (0 \text{ to } 0.15) = x$$

(3) Insert shim into stand and install bearing outer race only.

(4) Install stand into housing

(5) Check for shim to be in right place before oil seal installation.

(6) Install oil seal.

Fig.4-5 POWER DIVIDER (3/3)

4. POWER TRAIN

1. Housing	16. Plate	31. Plate
2. Stand	17. Plate	32. Rivet
3. Shaft	18. Plate	33. Capscrew
4. Gear	19. Plate	34. Capscrew
5. Gear	20. Plate	35. Capscrew
6. Gear	21. Plate	36. Machine screw
7. Gear	22. Bearing	37. Stud bolt
8. Support	23. Roller bearing	38. 90 degrees Elbow
9. Support	24. Ball bearing	39. Tube
10. Support	25. Ball bearing	40. Cap
11. Support	26. Ball bearing	41. Plug
12. Cover	27. Ball bearing	42. Shim
13. Plate	28. Roller bearing	43. Shim
14. Plate	29. Oil seal	44. Shim
15. Plate	30. Oil level gauge	

- (NOTE 1)
Install taking note on installation phase angle of pump mounting bolt hole and bearing oil fill in port of item 2 Stand and item 8, 9, 10, 11 Support.
(See figure)
- (NOTE 2)
Install item 25, 26 Bearing so that position of one side shield becomes on pump mounting side.
(See figure)

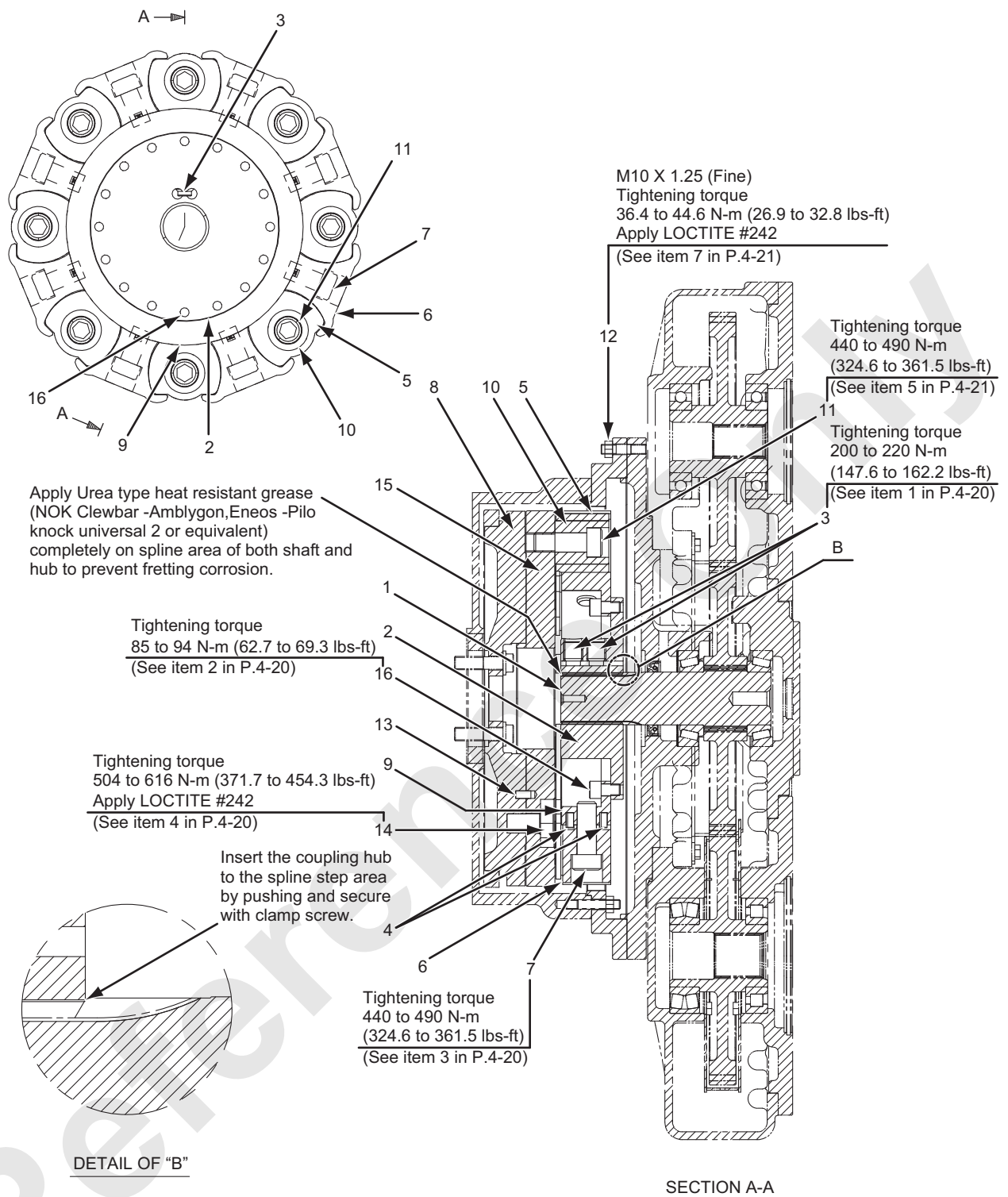

Fig.4-6 COUPLING

- | | | |
|-------------------|--------------------|-------------------|
| 1. Input shaft | 7. Capscrew | 13. Spring pin |
| 2. Clamping hub | 8. Flywheel | 14. Capscrew |
| 3. Clamping screw | 9. Outer hub | 15. Adapter plate |
| 4. Spring pin | 10. Bushing | 16. Capscrew |
| 5. Element | 11. Capscrew | |
| 6. Insert | 12. Nut (M10 fine) | |

Reference Only

5. HYDRAULIC SYSTEM

Reference Only

Reference Only

5.1 LOCATION OF MAIN HYDRAULIC COMPONENTS

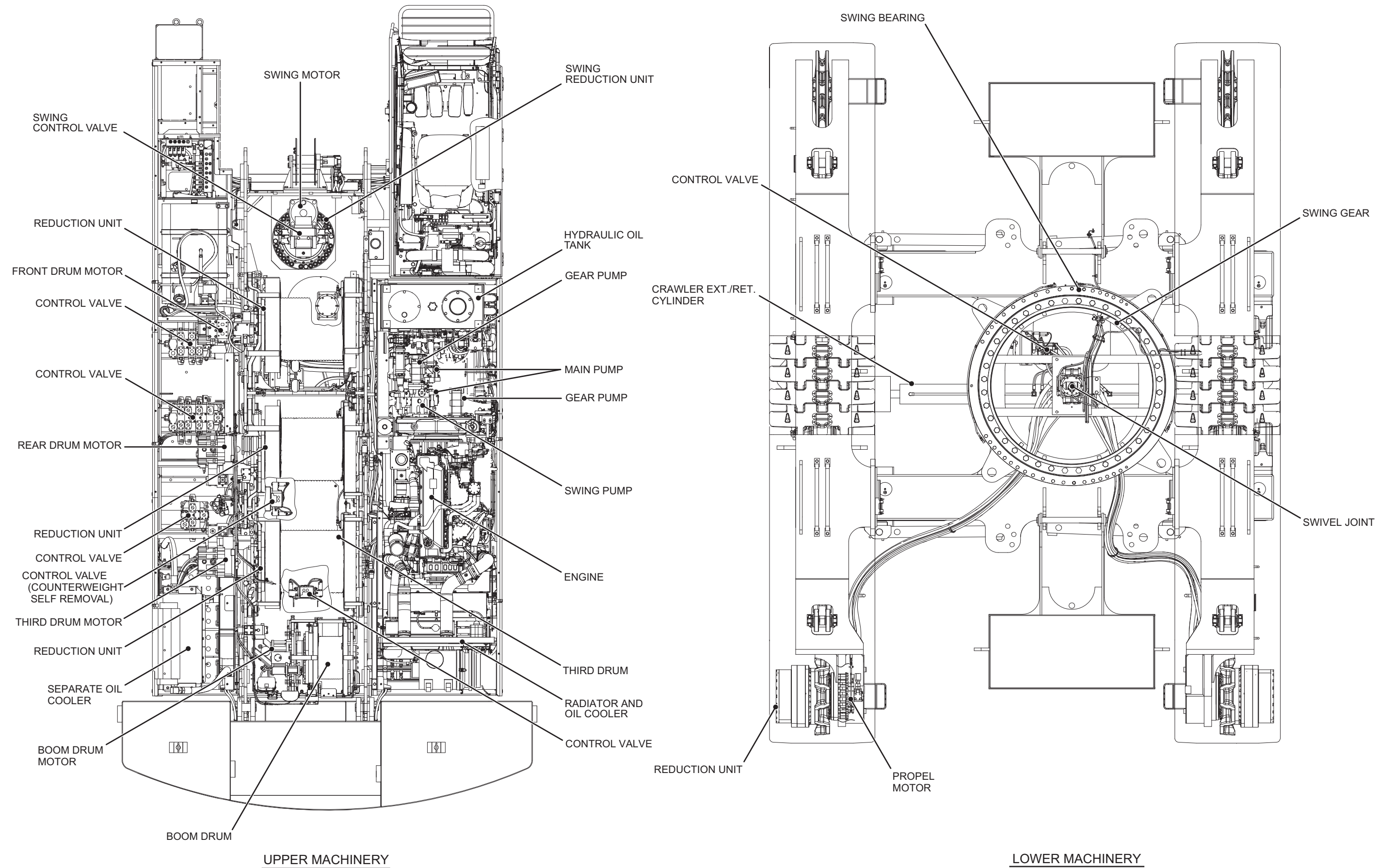

5. HYDRAULIC SYSTEM

WITH FREE FALL

COUNTERWEIGHT REMOVAL
OPTION

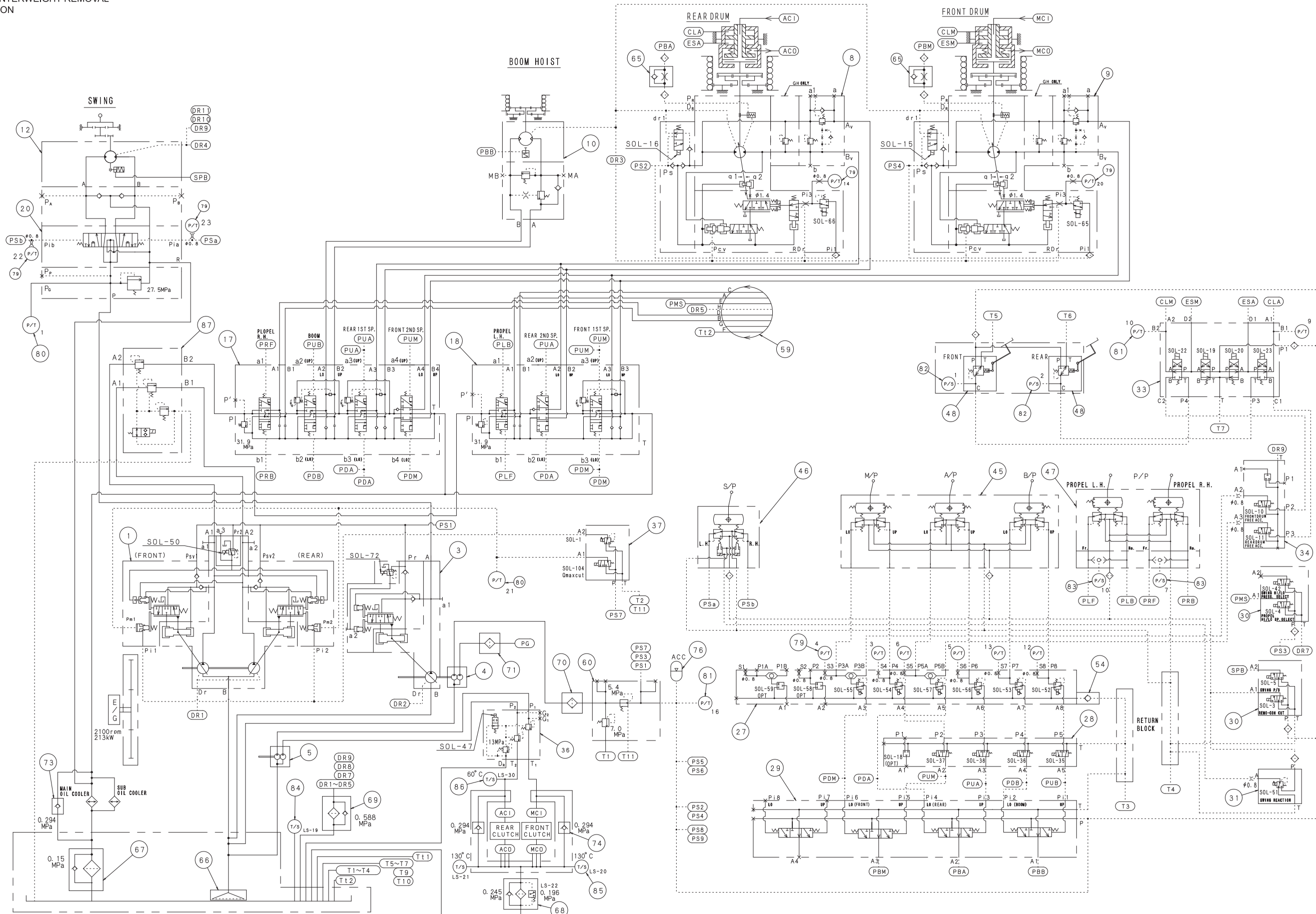

WITHOUT FREE FALL

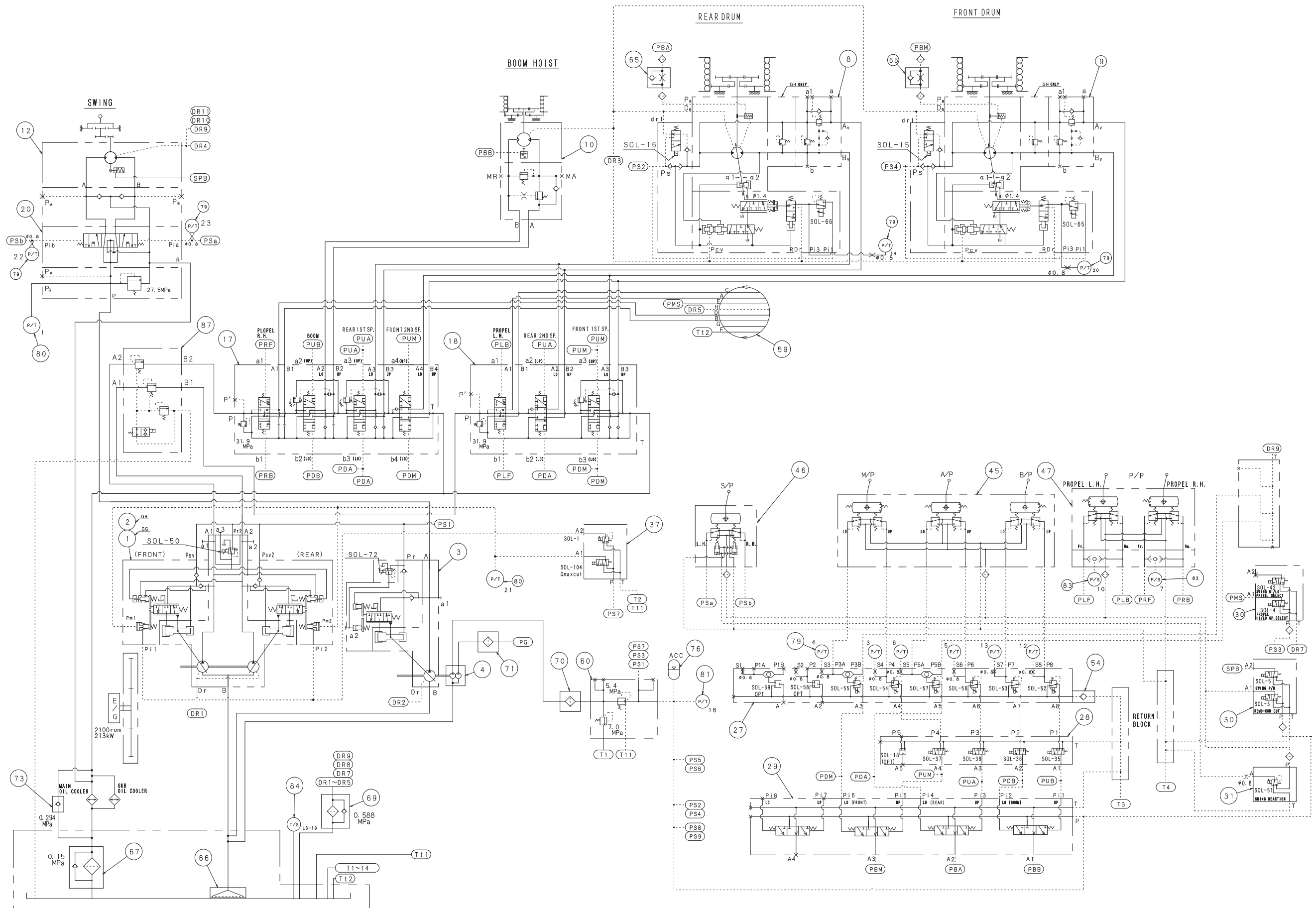

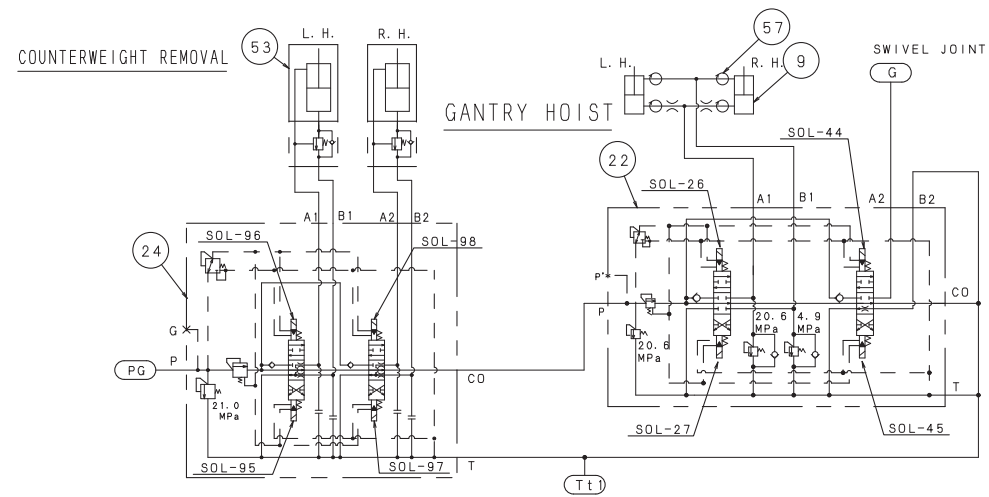
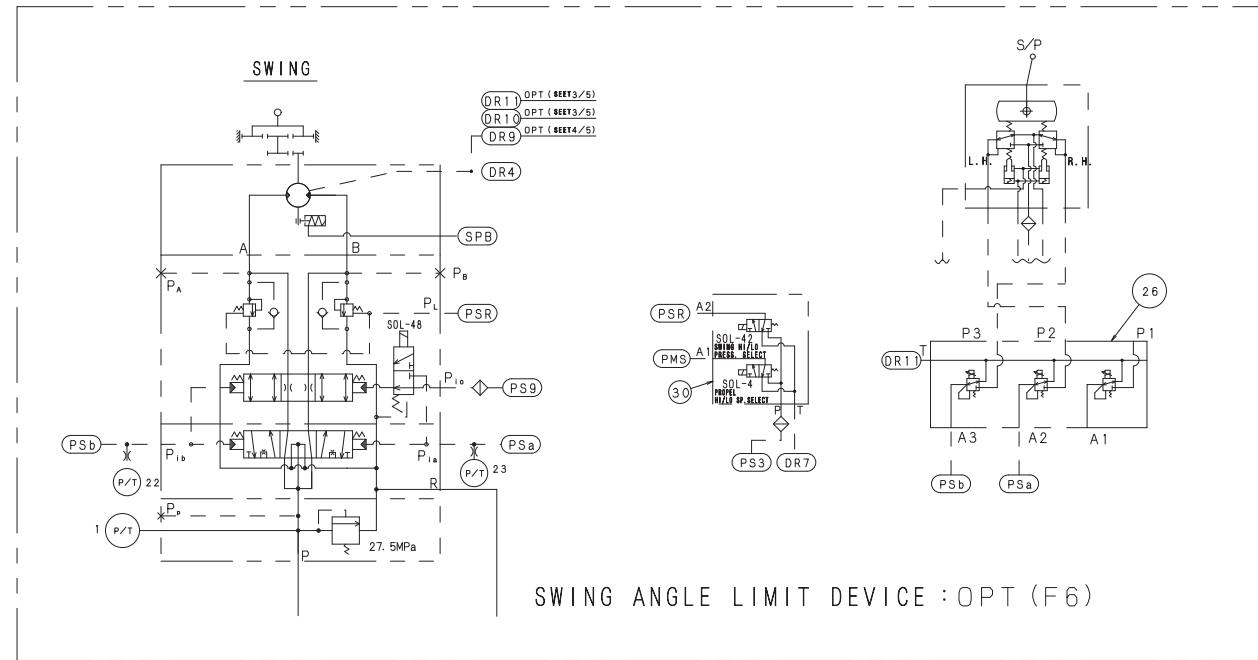
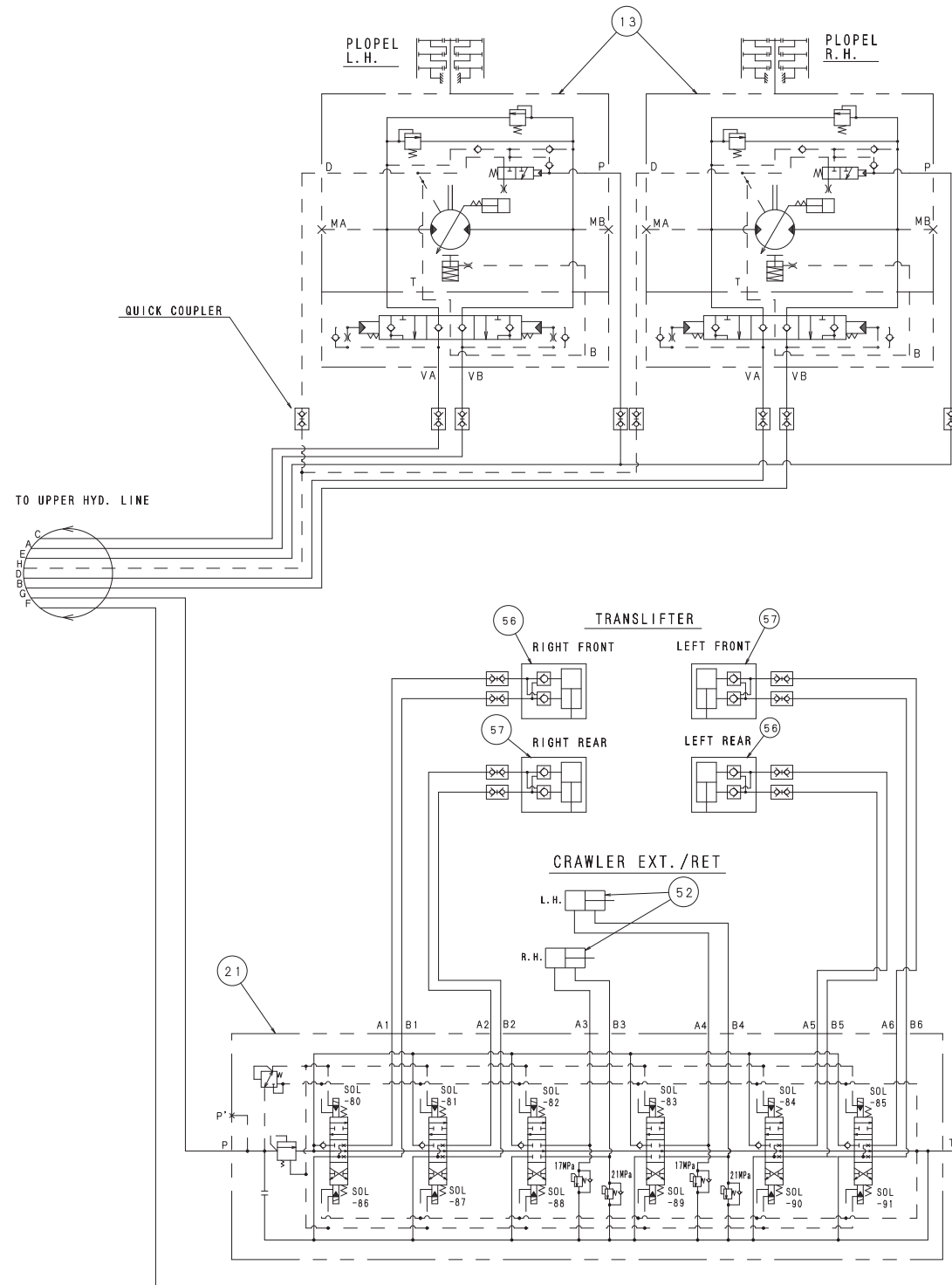

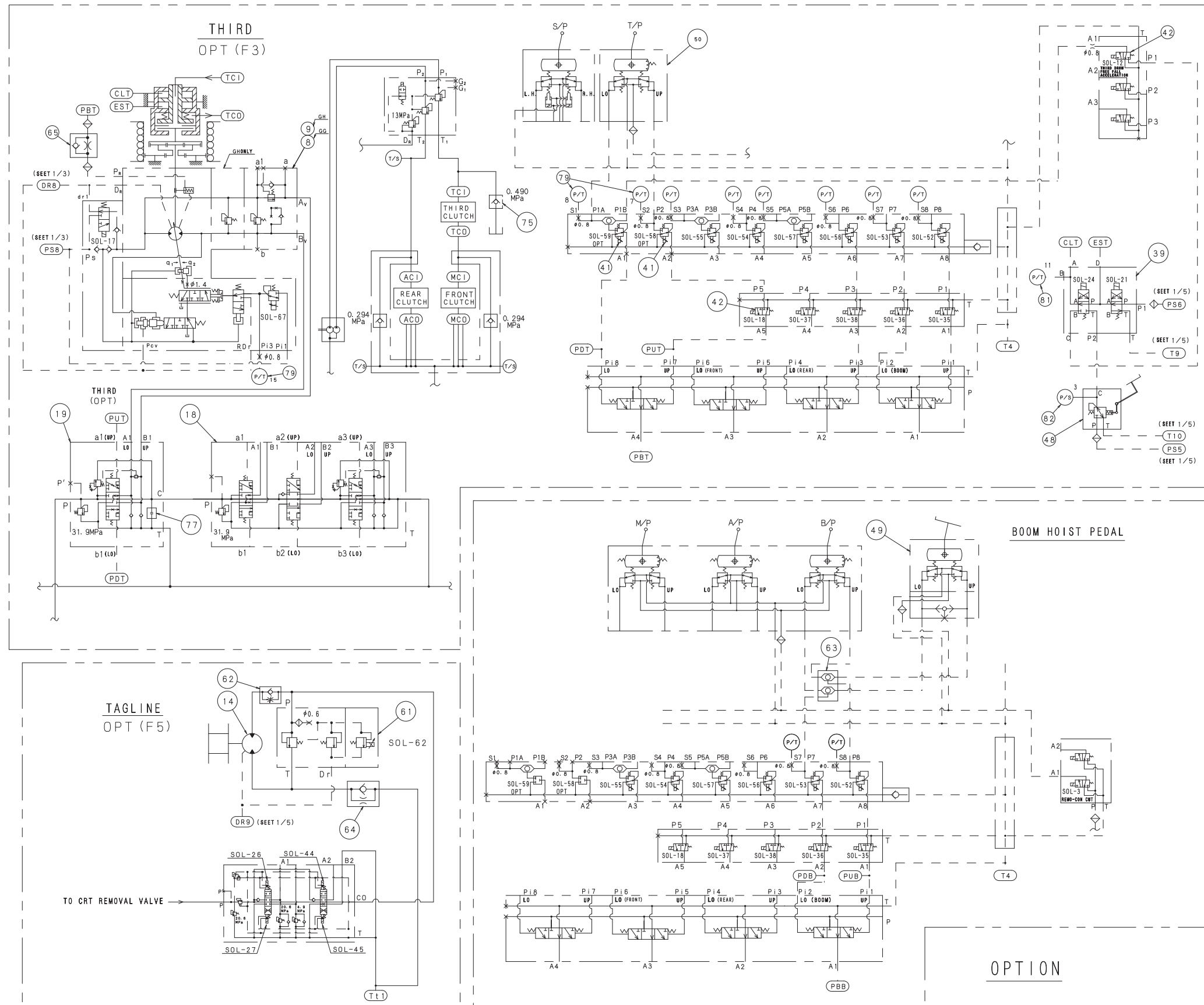

Reference Only

This page is blank for editing convenience.

5.2 HYDRAULIC CIRCUITS AND COMPONENTS

5.2.1 COMPONENT SPECIFICATIONS

Item	Name of Component		Specification
1	Pump		Swash plate type, variable displacement
2	(Boom, front and rear drum, propel, third)		Max. delivery :255ltr./min X 2 Max. working pressure :31.9MPa (325kgf/cm ²)
3	Pump (Swing)		Swash plate type, variable displacement Max. delivery :177ltr./min Max. working pressure :27.5MPa (280kgf/cm ²)
4	Gear pump	4-1 Control	Max. delivery :61ltr./min Max. working pressure :7.0MPa (71kgf/cm ²)
		4-2 Gantry	Max. delivery :40ltr./min Max. working pressure :20.6MPa (210kgf/cm ²)
5	Gear pump (Front and rear drum brake cooling)		Max. delivery :73ltr./min Max. working pressure :1.0MPa (10kgf/cm ²)
8	Motor		Swash plate type, variable displacement
9	(Front and rear drum, third drum)		Max. delivery :255ltr./min Max. working pressure :31.9MPa (325kgf/cm ²)
10	Motor (Boom)		Bent axis type, fixed displacement Max. delivery :255ltr./min Max. working pressure :31.9MPa (325kgf/cm ²)
12	Motor (Swing)		Swash plate type, variable displacement Max. delivery :177ltr./min Max. working pressure :27.5MPa (280kgf/cm ²)
13	Motor (Propel)		Swash plate type, 2 speed motor Max. delivery :255ltr./min Max. working pressure :31.9MPa (325kgf/cm ²)
14	Motor (Tagline) [Option]		Max. delivery :40ltr./min Relief pressure :13.7Mpa
17	Control valve (Propel R. H., boom, main2, aux.1)		Max. delivery :255ltr./min Max. working pressure :31.9MPa (325kgf/cm ²)
18	Control valve (Propel L. H., main1, aux.2)		Max. delivery :255ltr./min Max. working pressure :31.9MPa (325kgf/cm ²)
19	Control valve (Third drum) [Option]		Max. delivery :255ltr./min Max. working pressure :31.9MPa (325kgf/cm ²)
20	Control valve (Swing)		Max. working pressure :27.5MPa (280kgf/cm ²)
21	Control valve (Translifter / crawler ext.)		Crawler extending Press Push: 17.0MPa Pull : 21.0Mpa

5. HYDRAULIC SYSTEM

Item	Name of Component	Specification
22	Control valve (Gantry)	Set pressure :20.6MPa / 4.9Mpa :(210kgf/cm ² / 50kgf/cm ²)
24	Control valve (Counterweight self removal) (10000E-1 OPT.)	Max. delivery :40ltr./min Max. working pressure :21.0MPa (214kgf/cm ²)
26	Valve block (3-Section sol prop valve)	Swing angle limit
27	Valve block (8-section) (Automatic stop and speed control)	<ul style="list-style-type: none"> ·Front drum hoist remote control pressure ·Front drum lowering remote control pressure ·Rear drum hoist remote control pressure ·Rear drum lowering remote control pressure ·Boom raise remote control pressure ·Boom lowering remote control pressure ·Third drum hoist remote control pressure (Option) ·Third drum lowering remote control pressure (Option)
28	Valve block (5-section) (Limit stop)	<ul style="list-style-type: none"> ·Boom raise stop ·Boom lower stop ·Rear drum raise stop ·Front drum lower stop ·Third drum raise stop (Option)
29	Valve block (4-section) (Motor brake)	<ul style="list-style-type: none"> ·Front drum motor parking brake ·Rear drum motor parking brake ·Boom drum motor parking brake ·Third drum motor parking brake
30	Valve block X 2 (2-section) (Remo-con press. source cut etc)	<ul style="list-style-type: none"> ·Remo-con cut ·Swing parking brake ·Propel speed Hi / Low select ·Swing pressure select
31	Valve block (1-section) (Swing counterforce)	·Swing counterforce
33	Valve block (4-section) (Wet type free fall)	<ul style="list-style-type: none"> ·Rear drum clutch ·Rear drum emergency clutch ·Front drum emergency clutch ·Front drum clutch
34	Valve block (3-section) (Wet type free fall speed acceleration)	<ul style="list-style-type: none"> ·Front drum free fall speed acceleration ·Rear drum free fall speed acceleration
36	Valve block (For hyd. oil heat)	·Hydraulic oil heat
37	Valve block (2-section feathering Qmax cut)	
39	Valve block (2-section) (Third wet type free fall) [Option]	<ul style="list-style-type: none"> ·Third drum clutch ·Third drum emergency clutch engage
41	Solenoid valve [Option]	·Third drum automatic stop
42	Solenoid valve [Option]	·Third drum limit stop

Item	Name of Component	Specification	
45	Remote control valve (Front and rear drum, boom drum)	Front and rear drum : 2.65 to 2.94 Mpa (27 to 30kgf/cm ²) Boom drum : 2.50 to 2.79 Mpa (25.5 to 28.5kgf/cm ²)	
46	Remote control valve (Swing)	Swing : 1.62 to 1.92 Mpa (16.5 to 19.6kgf/cm ²)	
47	Remote control valve (Propel)	Press : 1.42 to 1.62MPa (14.5 to 16.5kgf/cm ²)	
48	Control valve (Brake)		
49	Remote control valve (Boom hoist pedal) [Option]		
50	Remote control valve (Third)	Third : 2.65 to 2.94MPa (27.0 to 30.0kgf/cm ²)	
51	Cylinder (Gantry hoist)	Φ75 X Φ40 X St304 X 2 Press Push : 20.6MPa Pull : 4.9Mpa	
52	Cylinder (Crawler Ext. /Ret.)	Φ150 X Φ70 X St1111 X 2 Press Push : 17.0MPa Pull : 21.0Mpa	
53	Cylinder (Counterweight self removal) (CKE900G OPT.)	Φ110 X Φ85 X St1330 X2	
54	Check valve		
	Oil cooler / radiator		
58	Swivel joint		
59	Swivel joint (8 port)	A, B, C, D : Propel E : Propel speed select F : Tank G : Crawler H : Drain	
60	Relief valve / reducing valve (Control)	Relief pressure	:7.0Mpa
		Reducing sec. pressure	:5.4Mpa
61	Sol. prop relief valve (Tagline) [Option]	Mechanical relief pressure setting	:14.7Mpa
		Proportional relief pressure setting	:13.7MPa (at 0.25 Amp.)
62	Flow control valve (Tagline) [Option]		
63	Shuttle valve [Option]		
64	Slow return check valve (Tagline) [Option]		
65	Slow return check valve (For motor brake)	Φ0.8	
66	Suction strainer	80 Mesh	5,300cm ²
67	Return filter	$\beta_{10} \geq 8$	22,500cm ²
68	Return filter (Wet type clutch)	10μ	7,230cm ²
69	Drain filter	10μ	2,000cm ²

5. HYDRAULIC SYSTEM

Item	Name of Component	Specification	
70	Line filter (Control)	100 Mesh (149 μ)	370cm ²
71	Line filter (Aux. actuator)	100 Mesh (149 μ)	380cm ²
73	Bypass check valve (Oil cooler)	0.294MPa	
74	Bypass check valve (Front, rear drum brake cooling)	0.294MPa	
75	Bypass check valve (For third) [Option]	0.490MPa	
76	Accumulator	N ₂ Gas 2,900cm ³	
77	Plug [Option]		
79	Pressure sensor (Remo-con press. detect)	3.0MPa	
80	Pressure sensor (For swing)	50.0MPa	
81	Pressure sensor (For clutch)	19.6MPa	
82	Pressure switch (Control / foot brake)		
83	Pressure switch (Propel remo-con press. detect)		
84	Hyd. oil temperature sensor (For hyd. oil tank)		
85	Hyd. oil temperature switch (Front, rear drum brake cooling)	130°C (266°F)	
86	Hyd. oil temperature switch (For hyd. oil heat)	60°C (140°F)	
87	Valve block	DPF re-generation	

5.2.2 LAYOUT OF HYDRAULIC COMPONENTS

1. UPPER MACHINERY

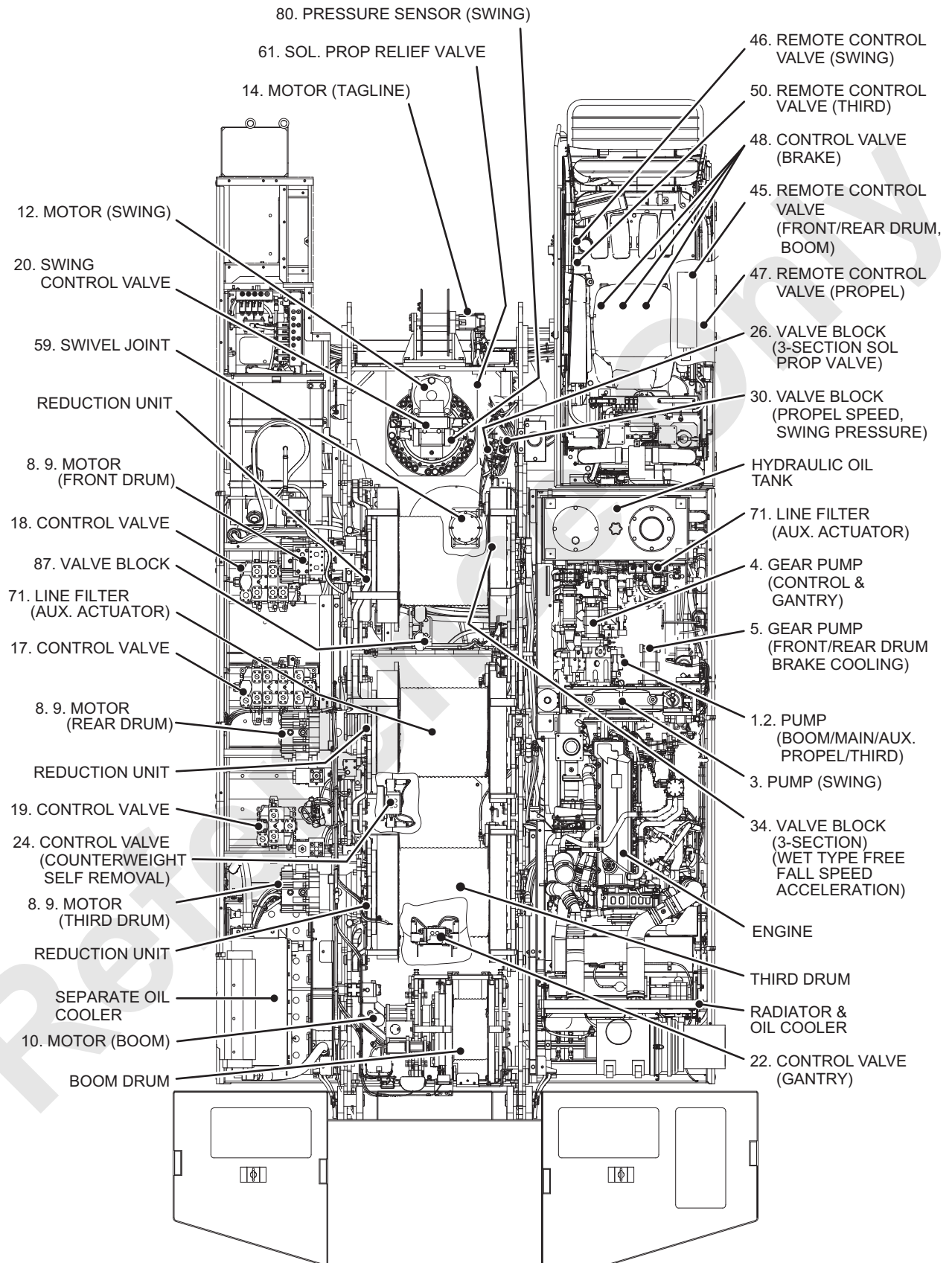

5. HYDRAULIC SYSTEM

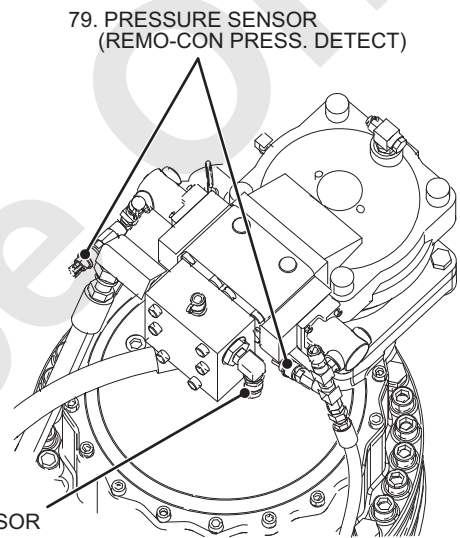
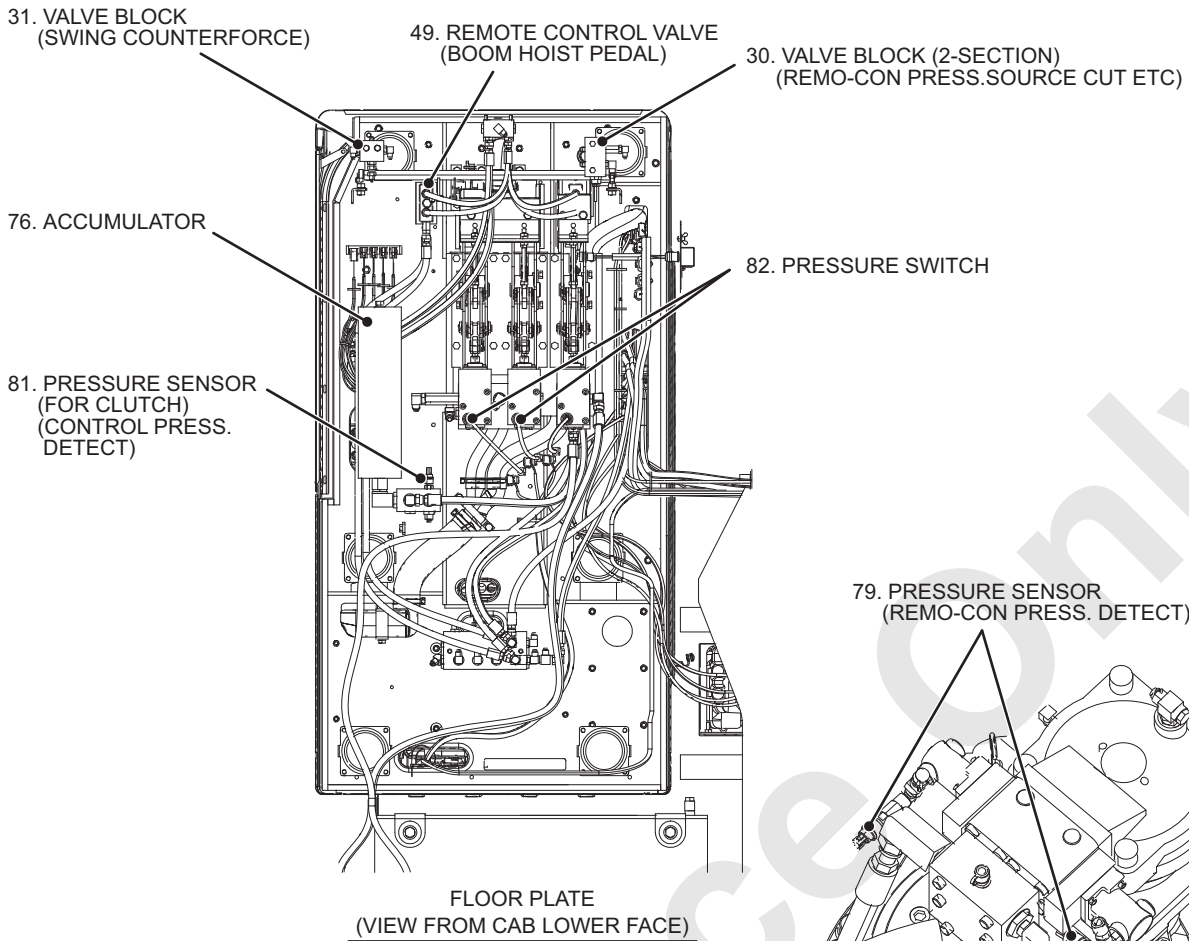

12. MOTOR (SWING)

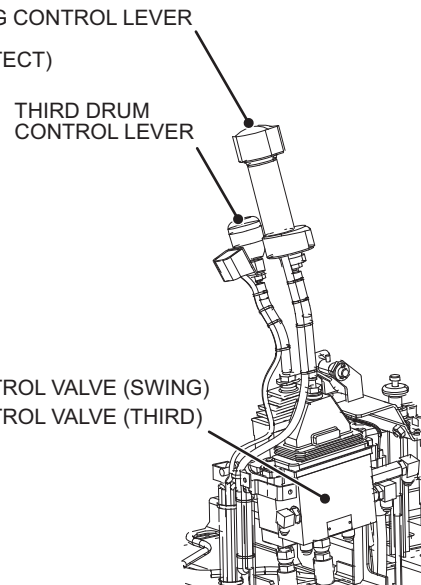
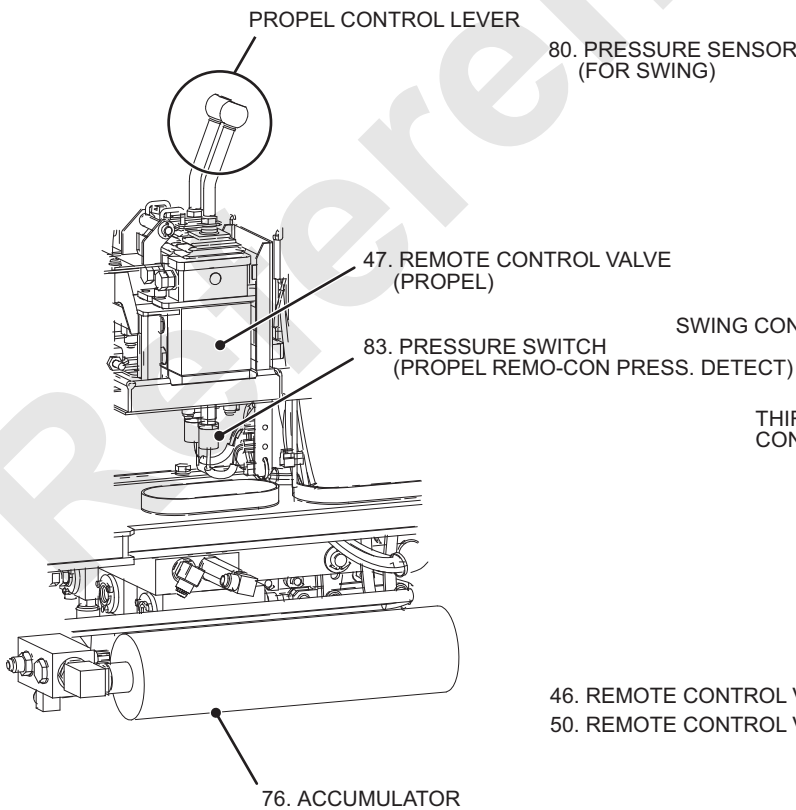

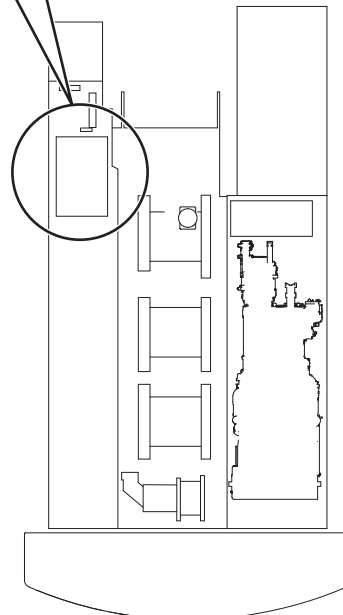
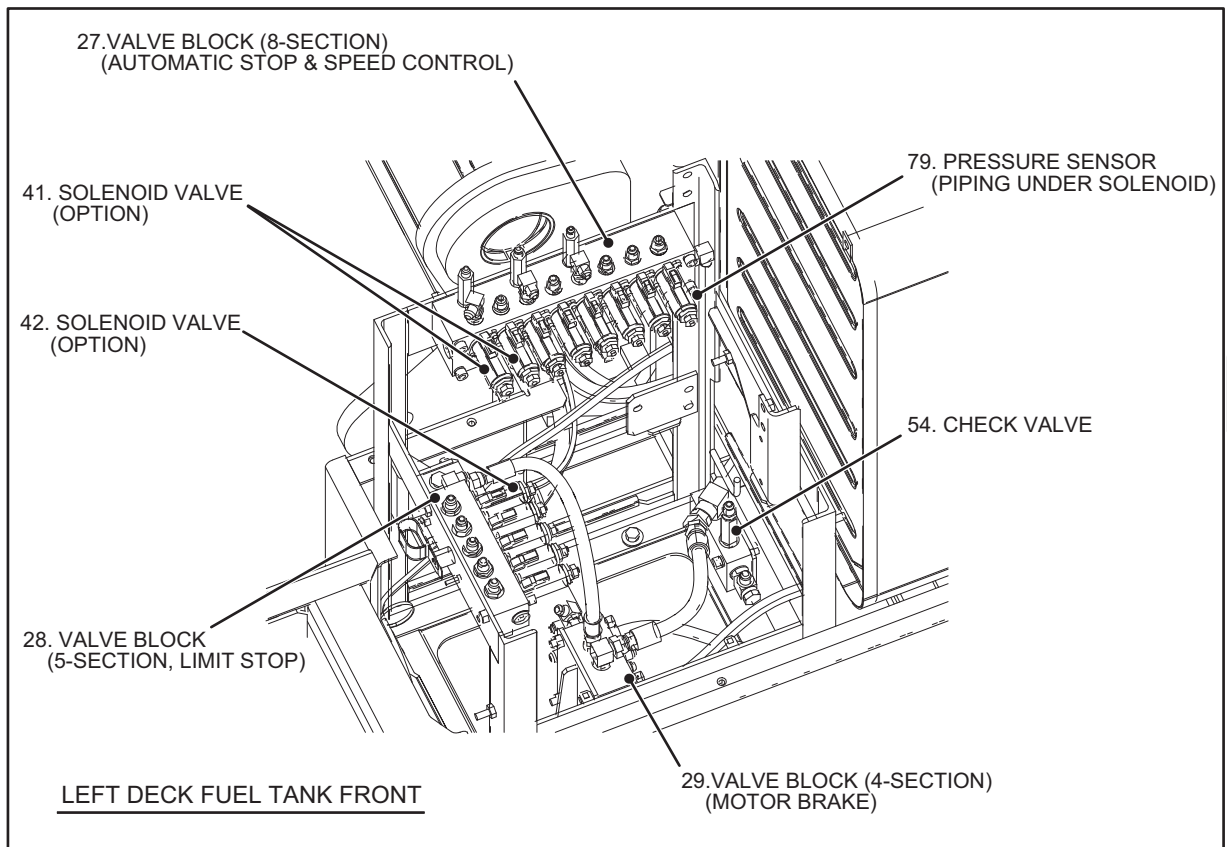

Referen

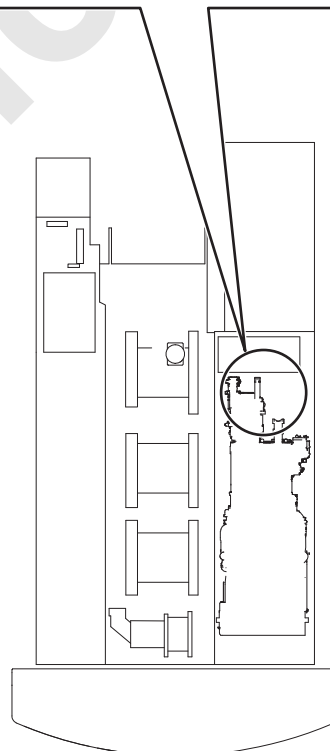
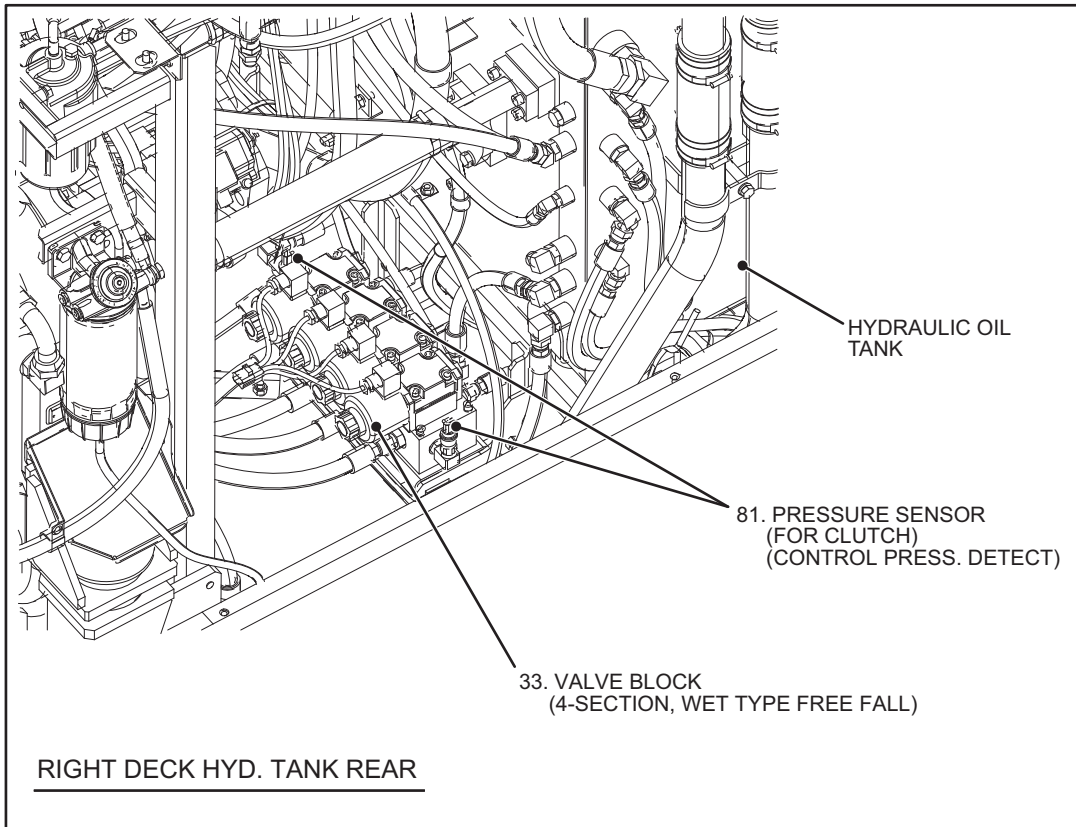

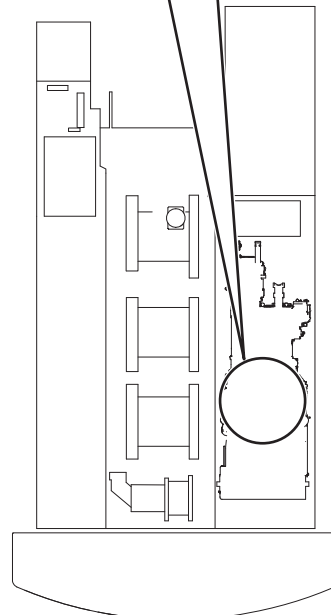
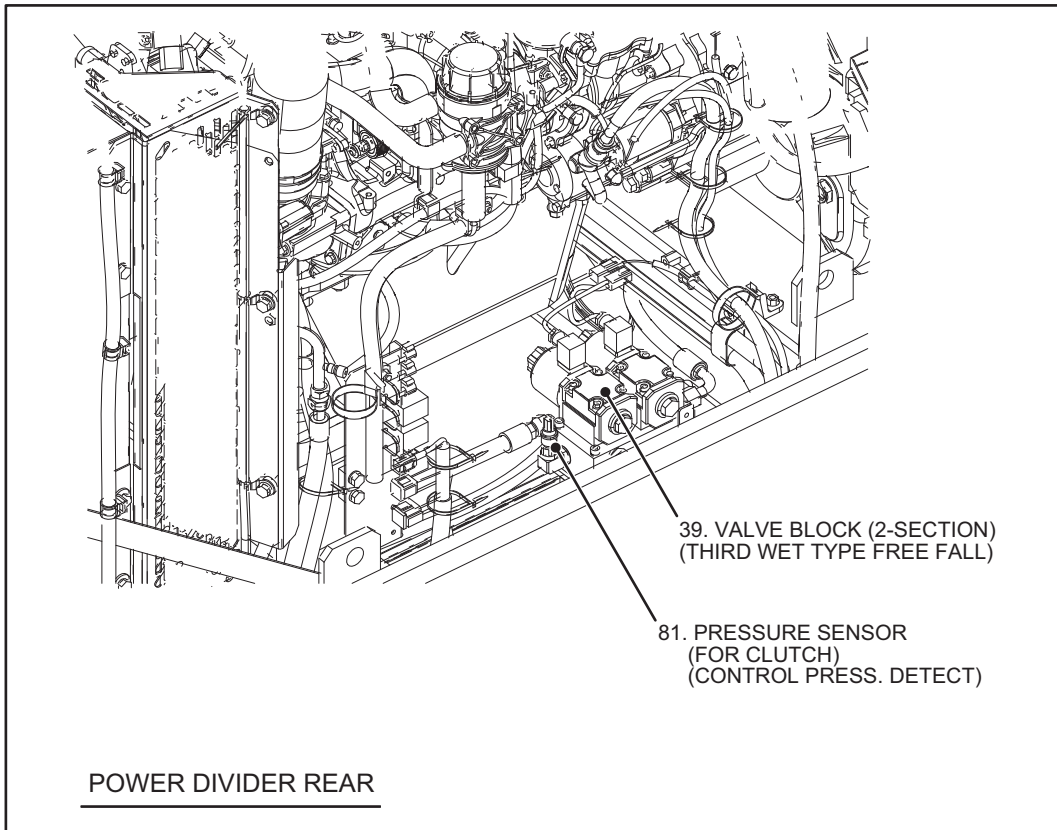

5. HYDRAULIC SYSTEM

2. DRUM COOLING LINE

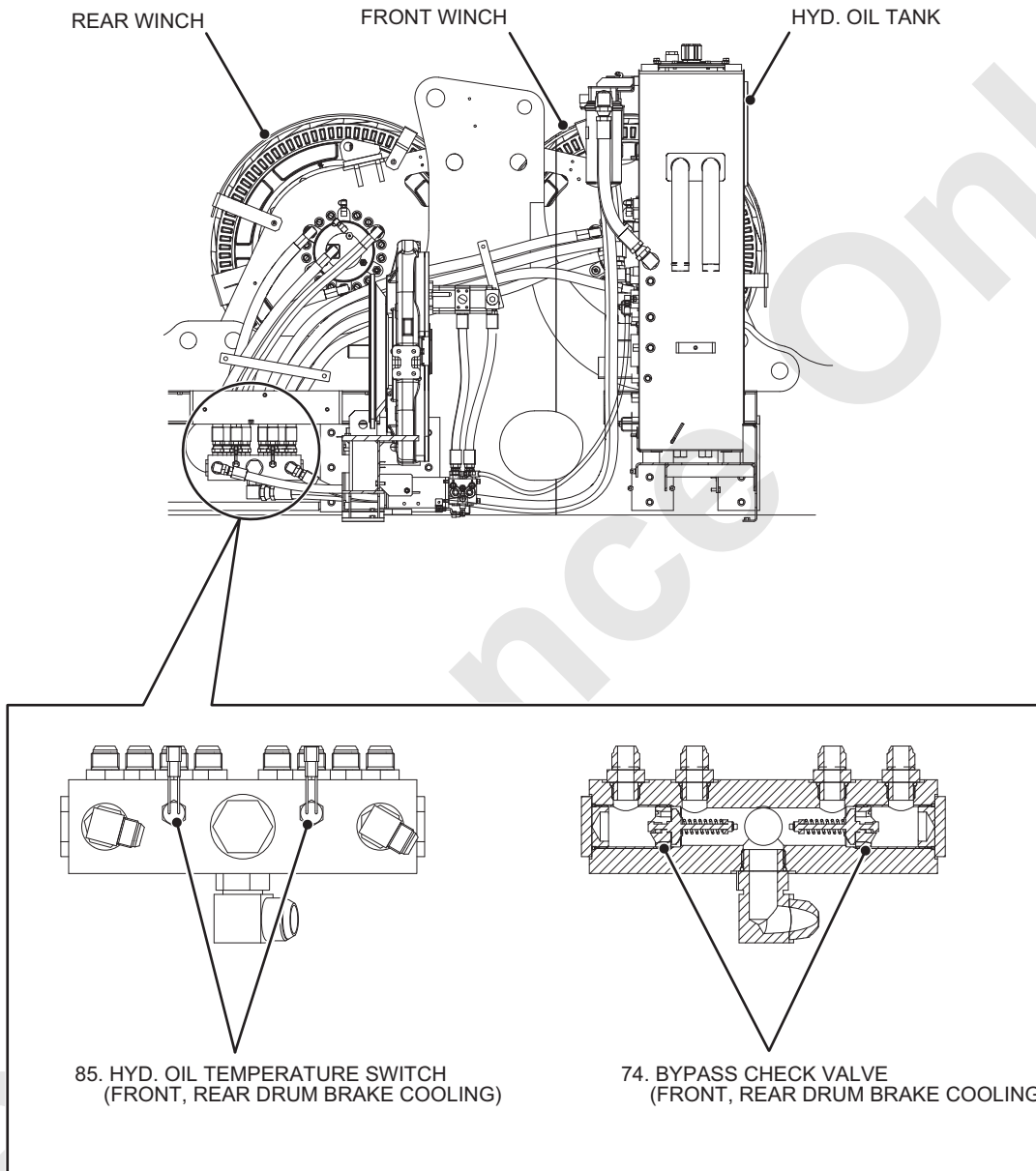

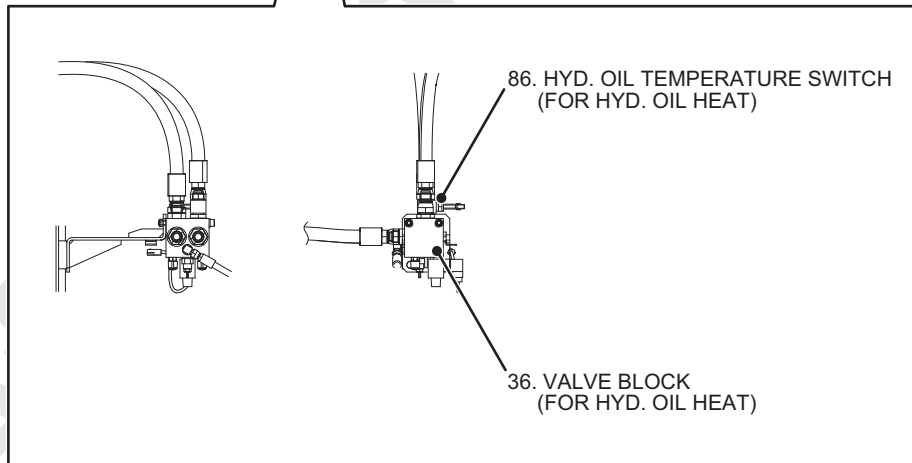
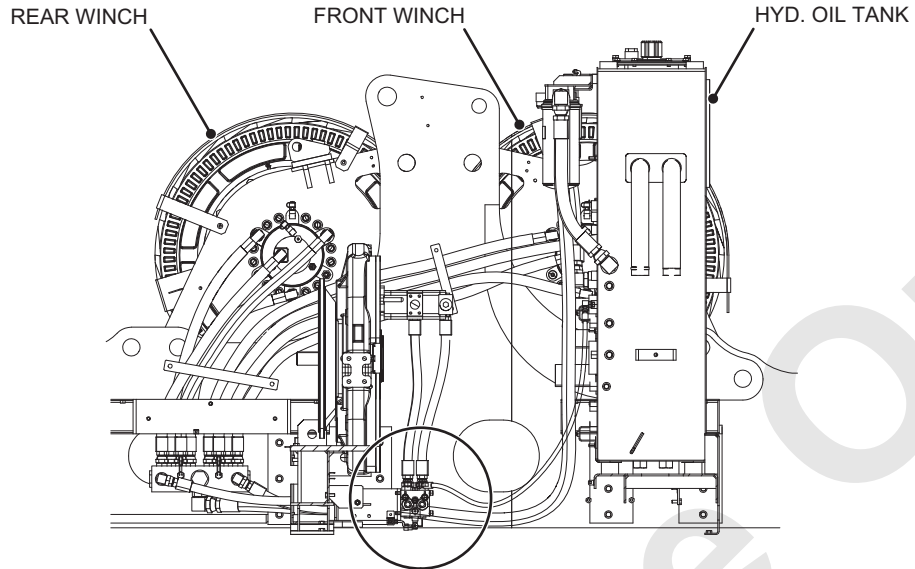

5. HYDRAULIC SYSTEM

3. HYDRAULIC OIL TANK

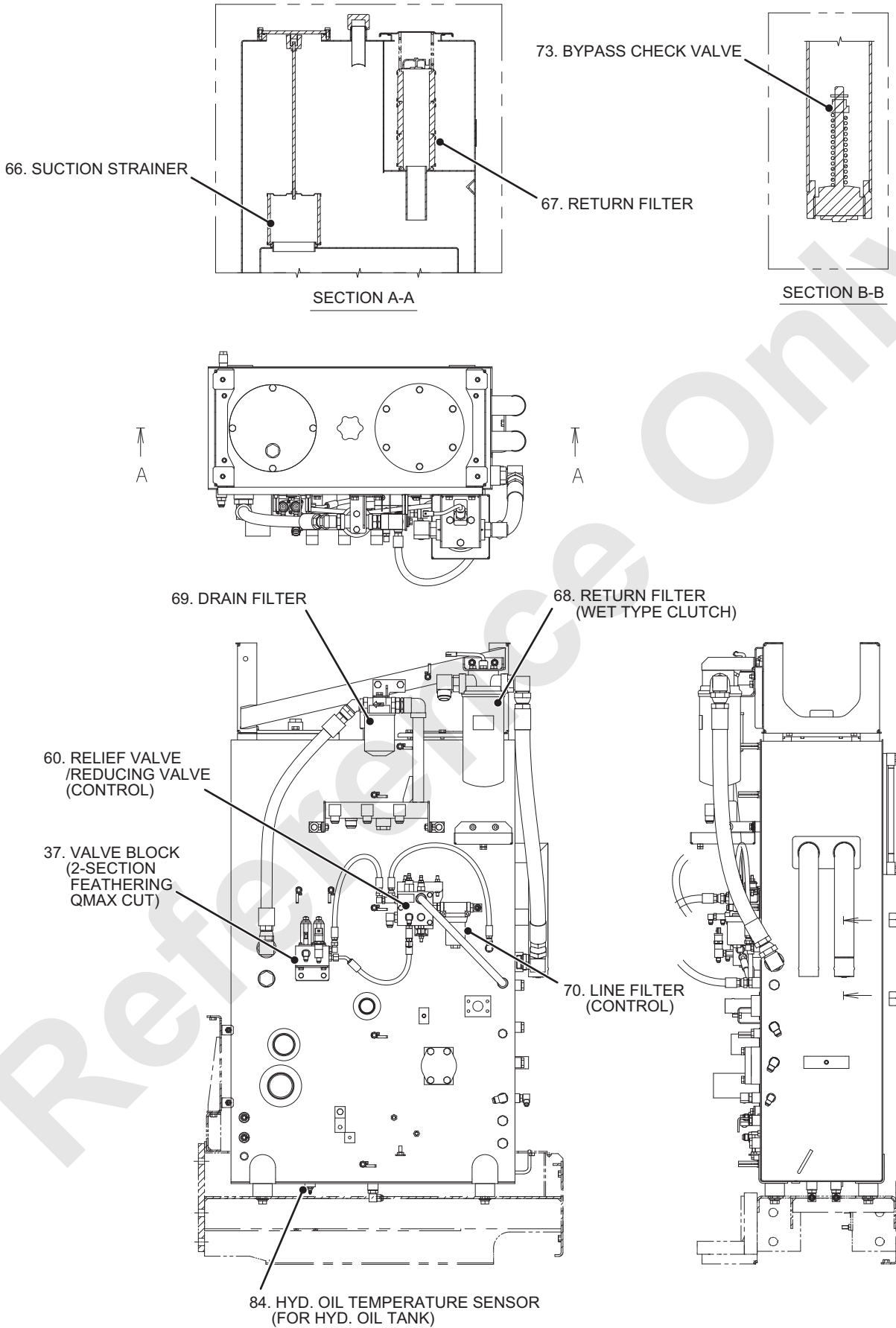

4. GANTRY

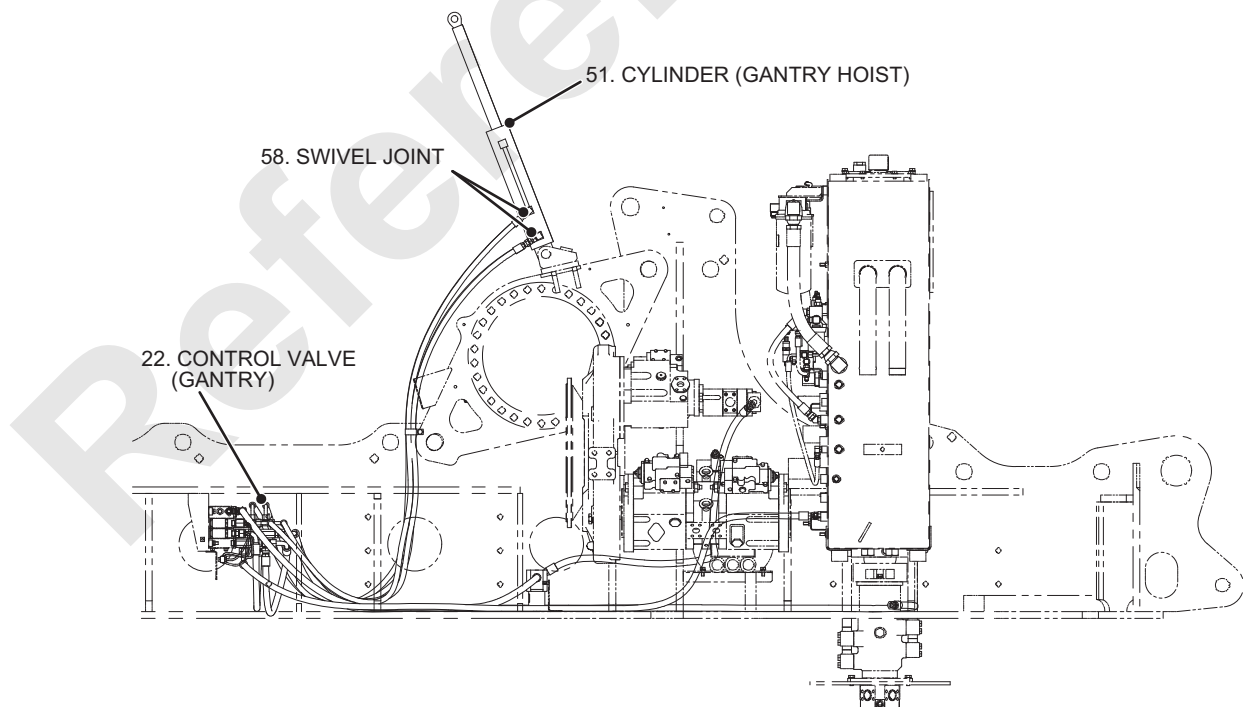
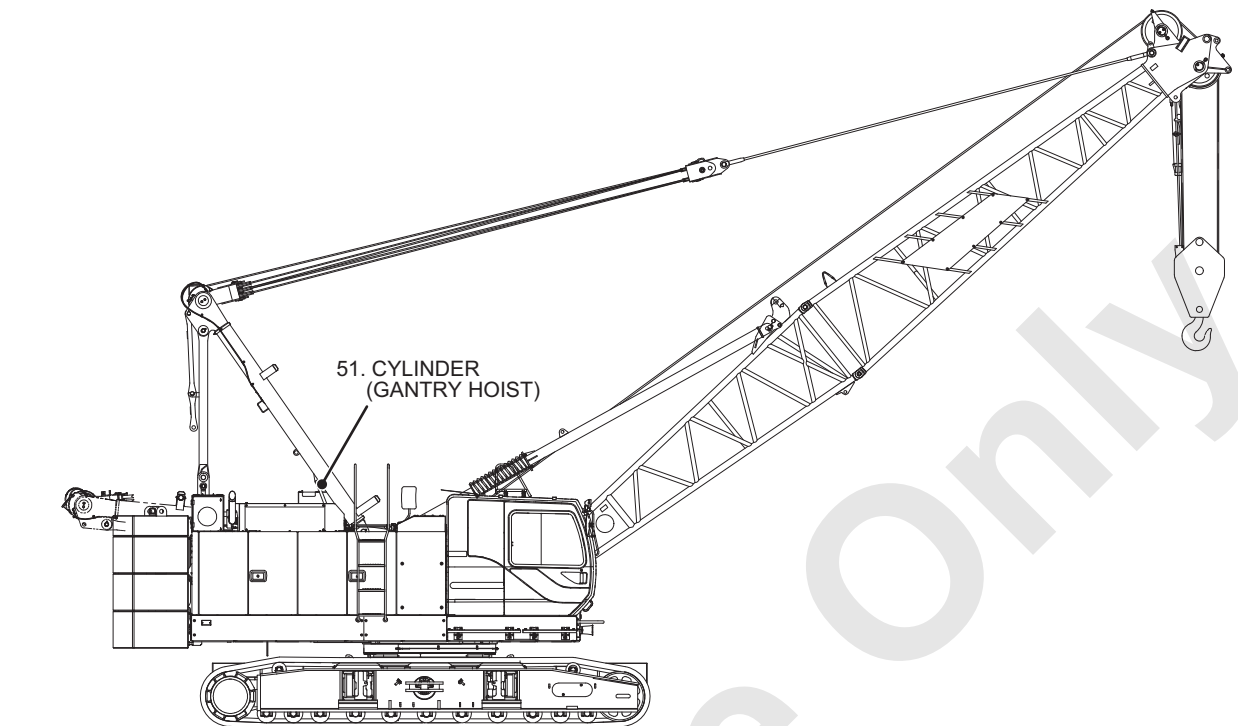

5. HYDRAULIC SYSTEM

5. WINCH MOTOR

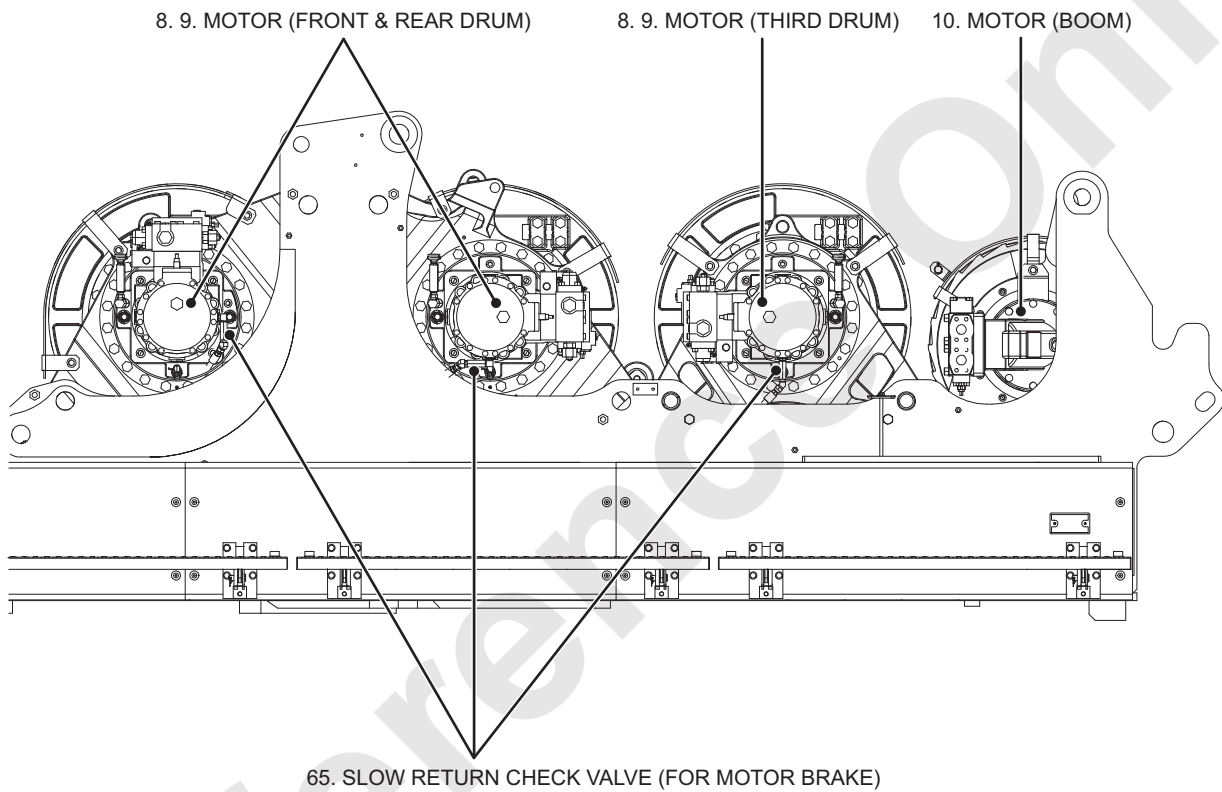

6. LEFT DECK

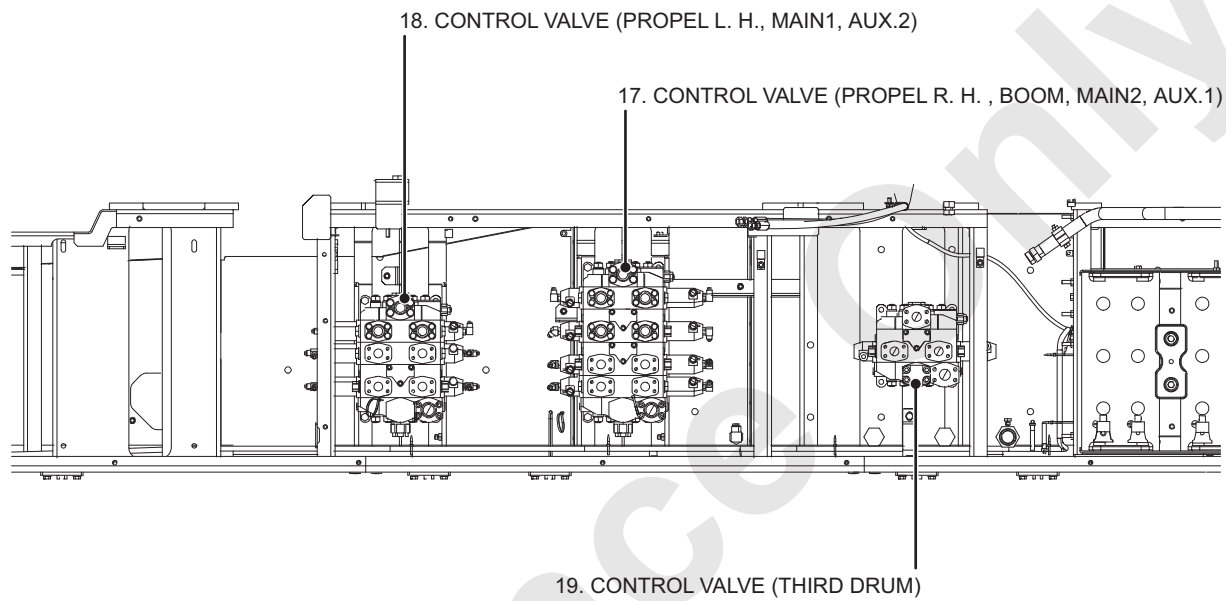

5. HYDRAULIC SYSTEM

7. HYDRAULIC OIL PUMP

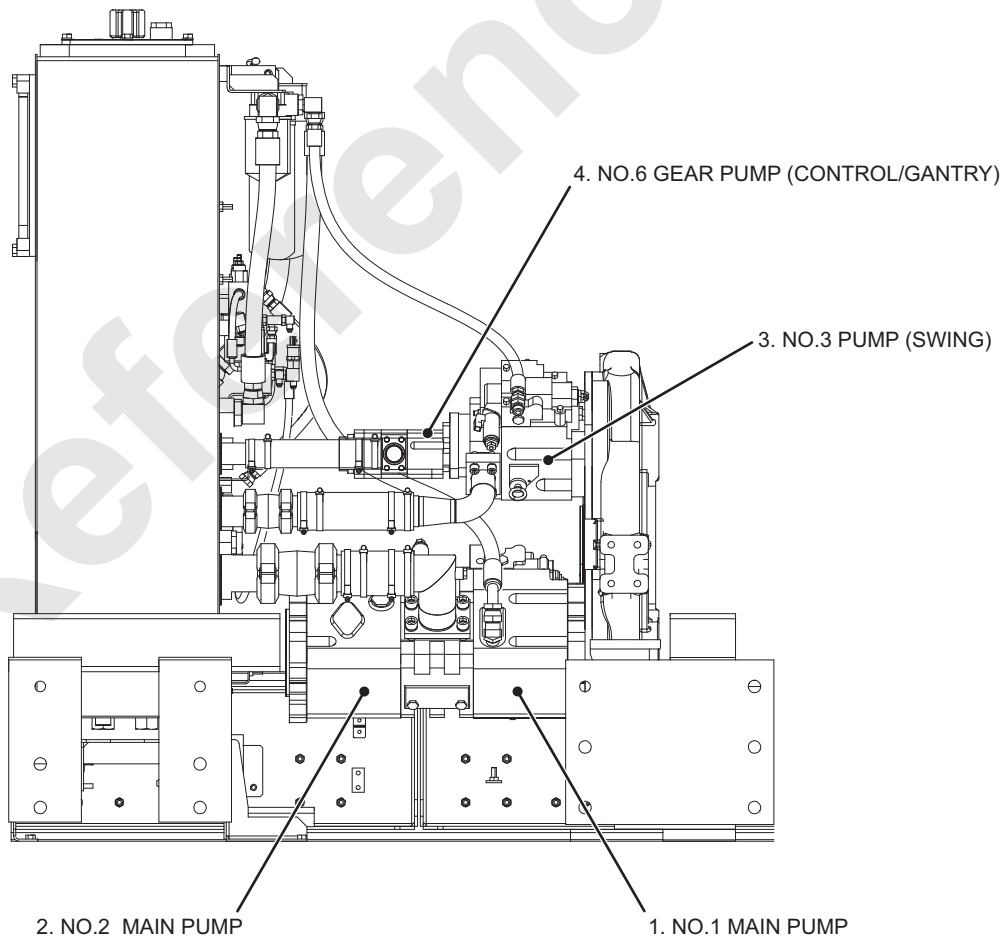
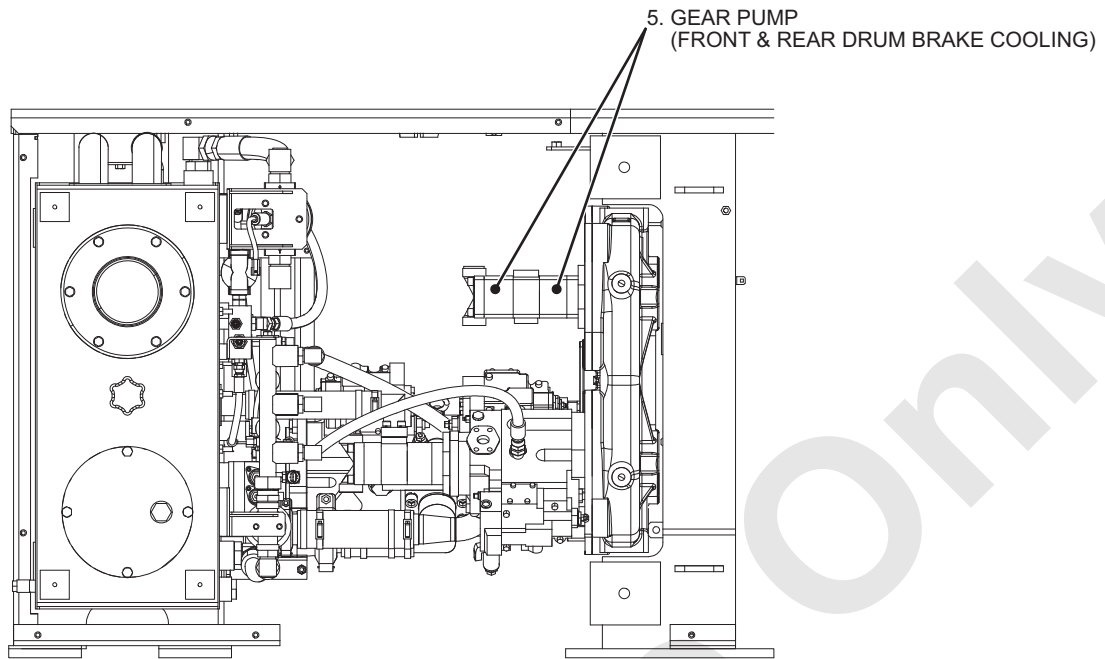

8. LOWER MACHINERY

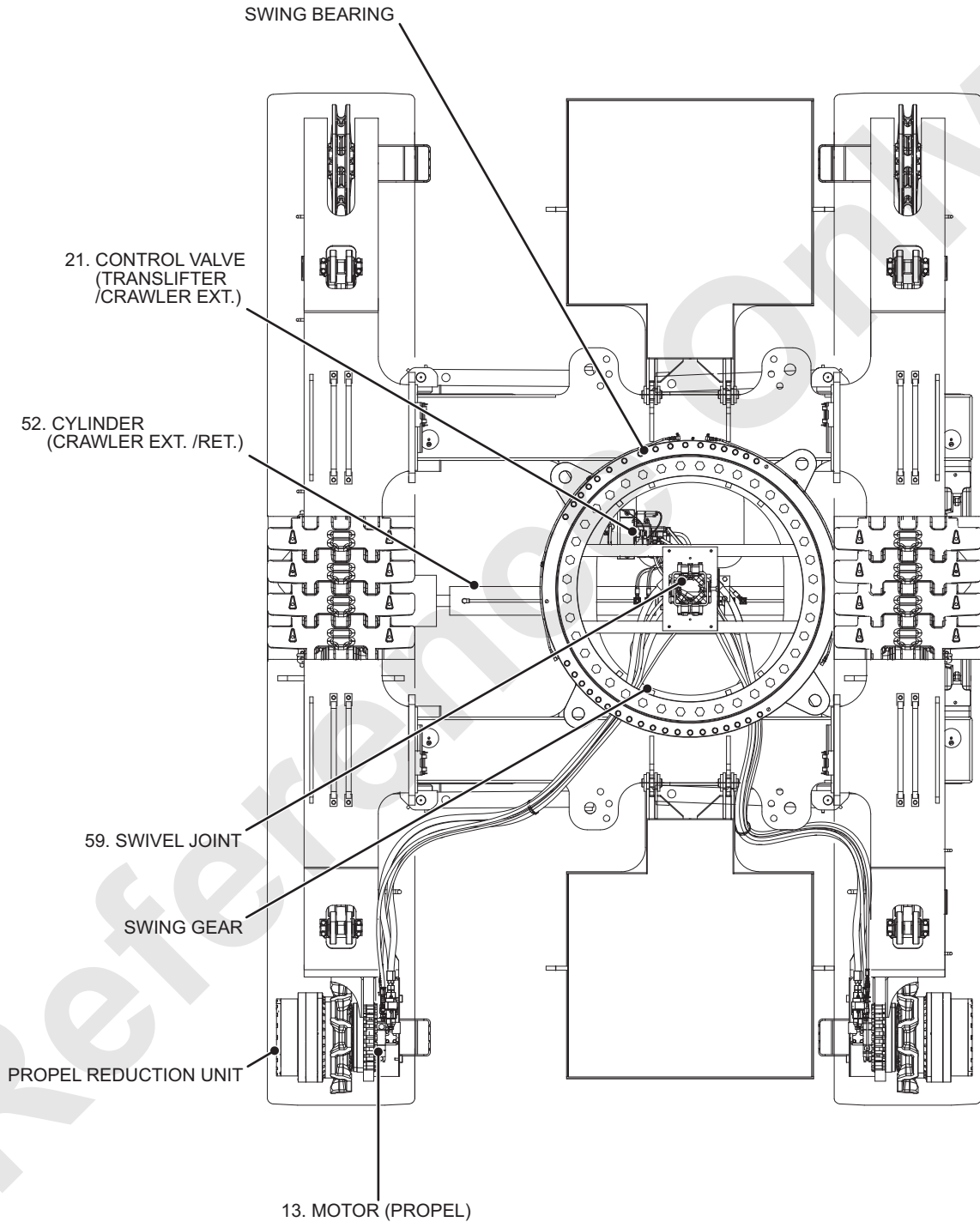

This page is blank for editing convenience.

5.3 HYDRAULIC SYSTEM

5.3.1 PREFACE

This chapter provides a general outline of the overall hydraulic system.

5.3.2 OUTLINE

The pressurized oil in this circuit is supplied by the 3 variable displacement pumps driven with the power divider directly connected to the engine and 2 section gear pumps connected to them.

2 pumps (2 section) out of these 3 variable displacement pumps are for front drum, rear drum, boom drum and propel and 1 other pump is for swing and crawler extending.

Inner side pump out of 2 section gear pumps directly connected to the swing pump is for control purpose and outer side one is for auxiliary units.

2 gear pumps directly connected with power divider are for front and rear drum brake cooling.

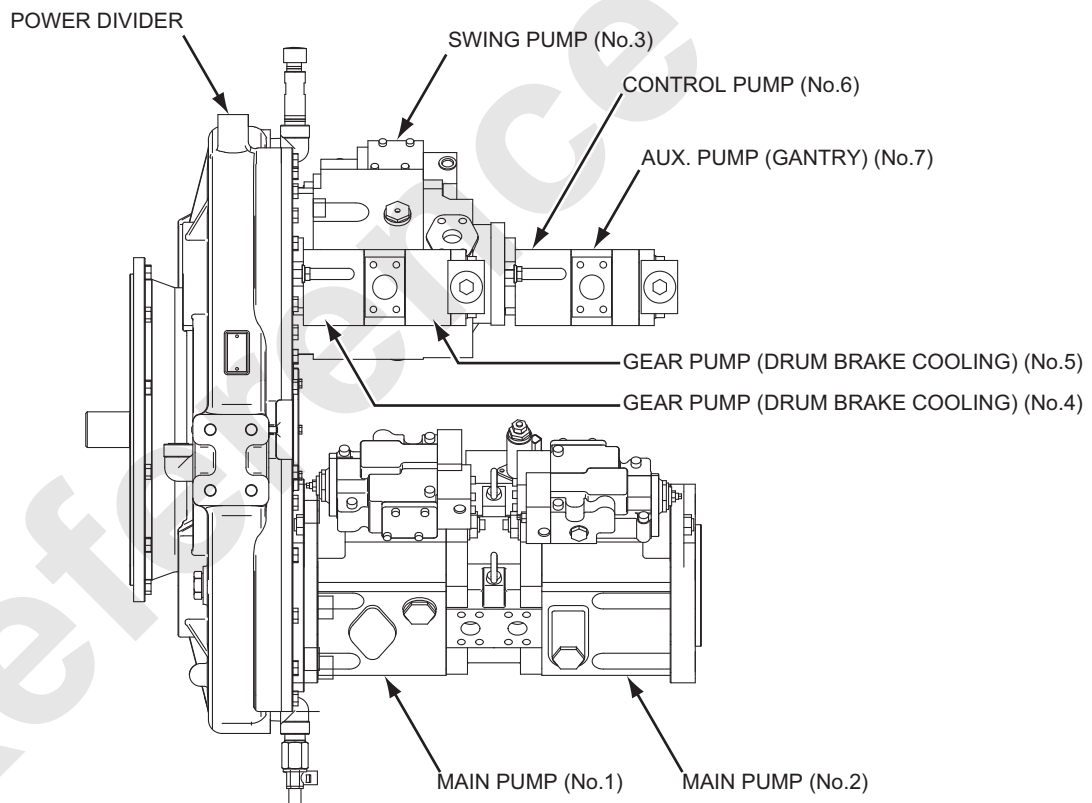

5. HYDRAULIC SYSTEM

5.3.3 OIL FLOW FROM No.1 AND No.2 PUMPS

No.1 and No.2 pumps are main pumps and are tandem connected variable displacement double pumps.

At neutral, pressurized oil from No.1 pump flows into 4 section side control valve circuit (front / rear drum / right propel / boom).

At the same time, pressurized oil from No.2 pump flows into 3 section side control valve circuit (front / rear drum / left propel) and passes through each control valve and return to the oil tank without load.

When any of control valve spools is moved by pressurized control oil from the remote control valve, pressurized main pump oil is led to each actuator.

When the inching speed switch is handled, inching speed solenoid becomes energized to actuate the pump regulator and minimize oil delivery from the main pump.

OIL FLOW FROM No.1 AND No.2 PUMPS

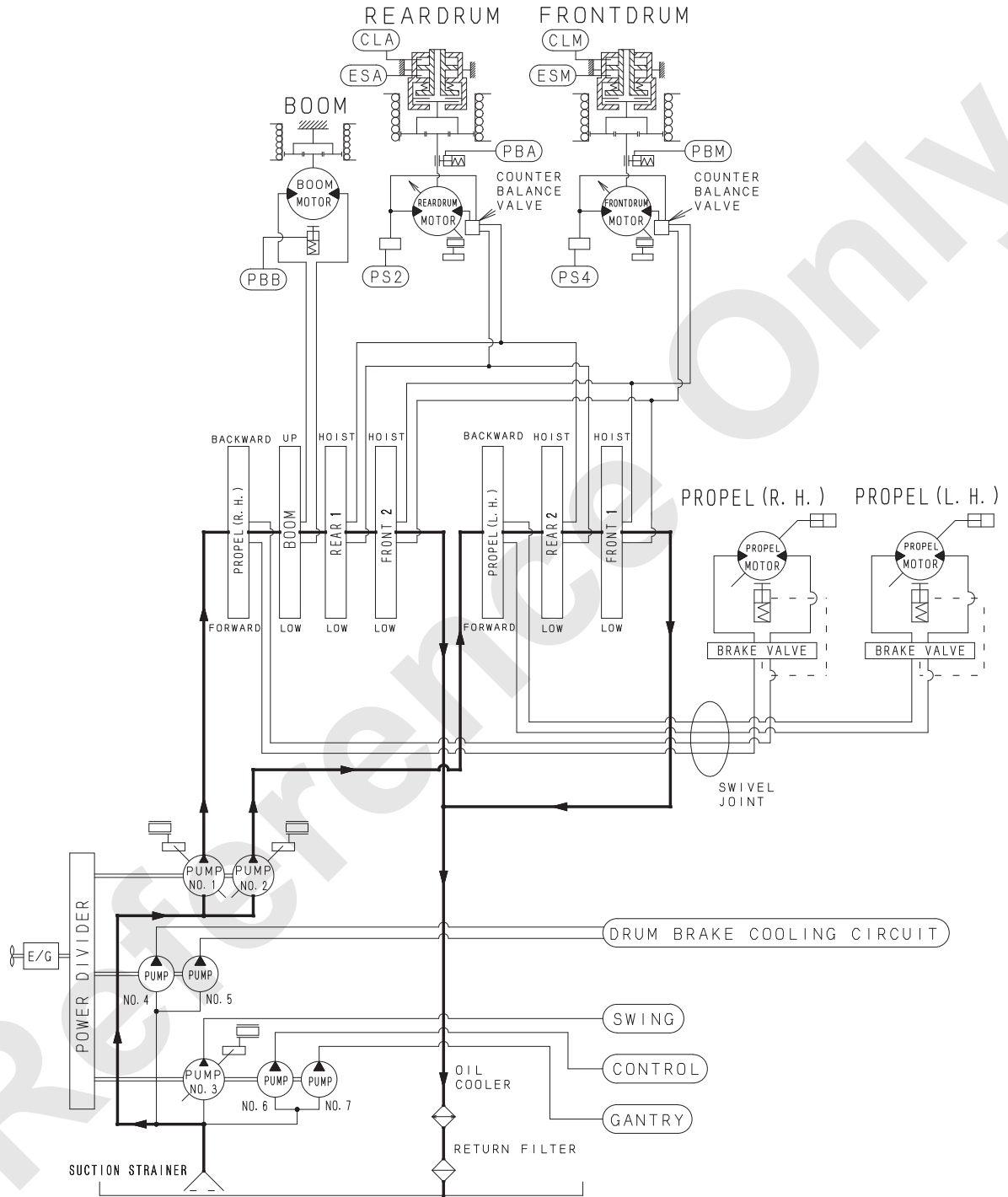

5. HYDRAULIC SYSTEM

5.3.4 OIL FLOW FROM No.3 PUMP

No.3 pump is swing pump and is variable displacement pump.

When the swing remote control valve is in neutral, pressurized oil from No.3 pump flows into the swing control valve and returns to oil tank without load.

When the swing control valve is actuated with the pressurized oil from the remote control valve, pressurized oil from the swing pump flows into the swing motor to swing the upper machinery.

Reference Only

OIL FLOW FROM No.3 PUMP

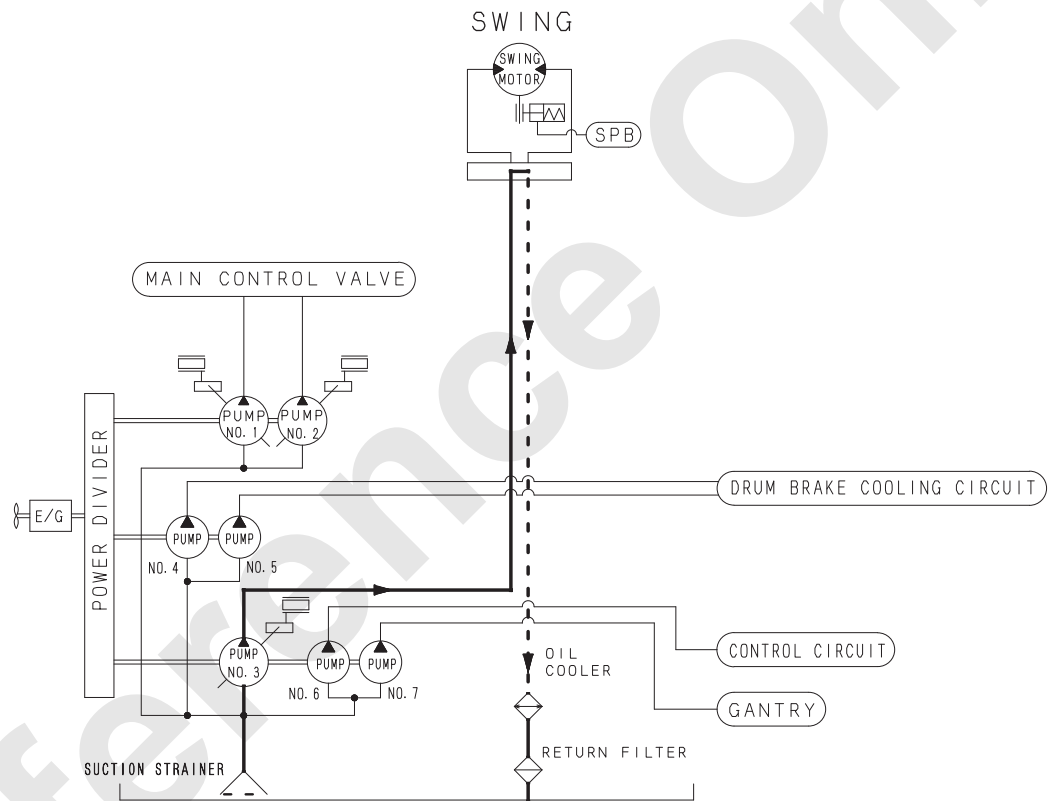

5. HYDRAULIC SYSTEM

5.3.5 OIL FLOW FROM No.4 AND No.5 PUMPS (FRONT, REAR DRUM BRAKE COOLING)

No.4 and No.5 pumps are gear pumps and are used for cooling of front and rear drum brake (clutch).

The pressurized oil from both pumps passes through the front and rear drum brake (clutch) and returns to the tank through the filter.

Reference Only

OIL FLOW FROM No.4 AND No.5 PUMPS (FRONT, REAR DRUM BRAKE COOLING)

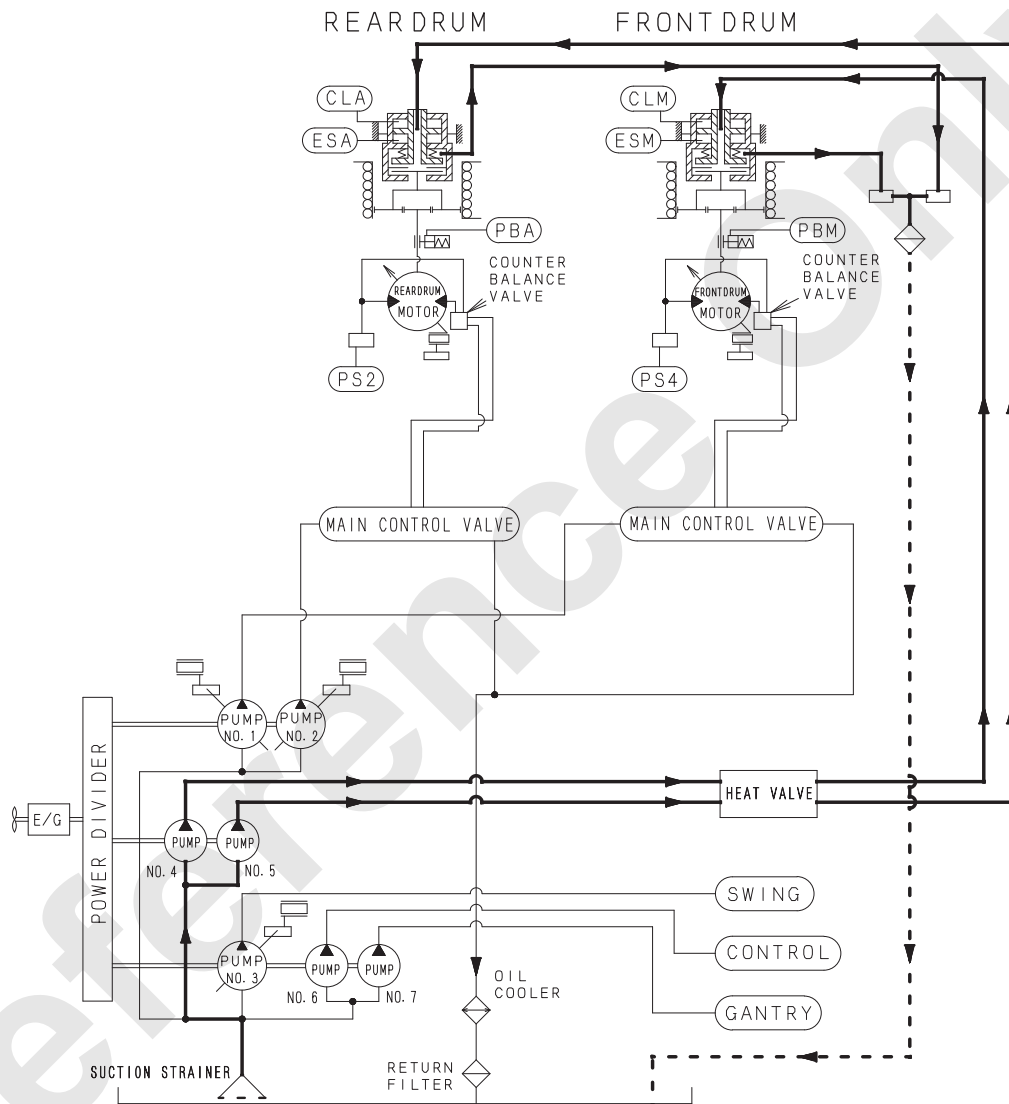

5. HYDRAULIC SYSTEM

5.3.6 OIL FLOW FROM No.6 PUMP

No.6 pump is gear pump and is used for control. Pressurized oil from the pump passes through the line filter and is pressure-reduced to 5.4 MPa and flows into the accumulator and then flows into 2 4-section valve and 2 2-section valve and the foot brake valve.

1. WHEN FUNCTION LOCK LEVER IS IN "LOCK" POSITION

When the function lock lever is in "LOCK" position, pressurized oil sent to 2-section valve is shut off with the function lock (Remo-con cut) solenoid valve (SOL-3) and is not sent to the remote control valve.

Therefore under this condition, even when the control valve is operated, control pressure would not be generated and the machine would not move.

OIL FLOW FROM No.6 PUMP (WHEN FUNCTION LOCK LEVER IS IN "LOCK" POSITION)

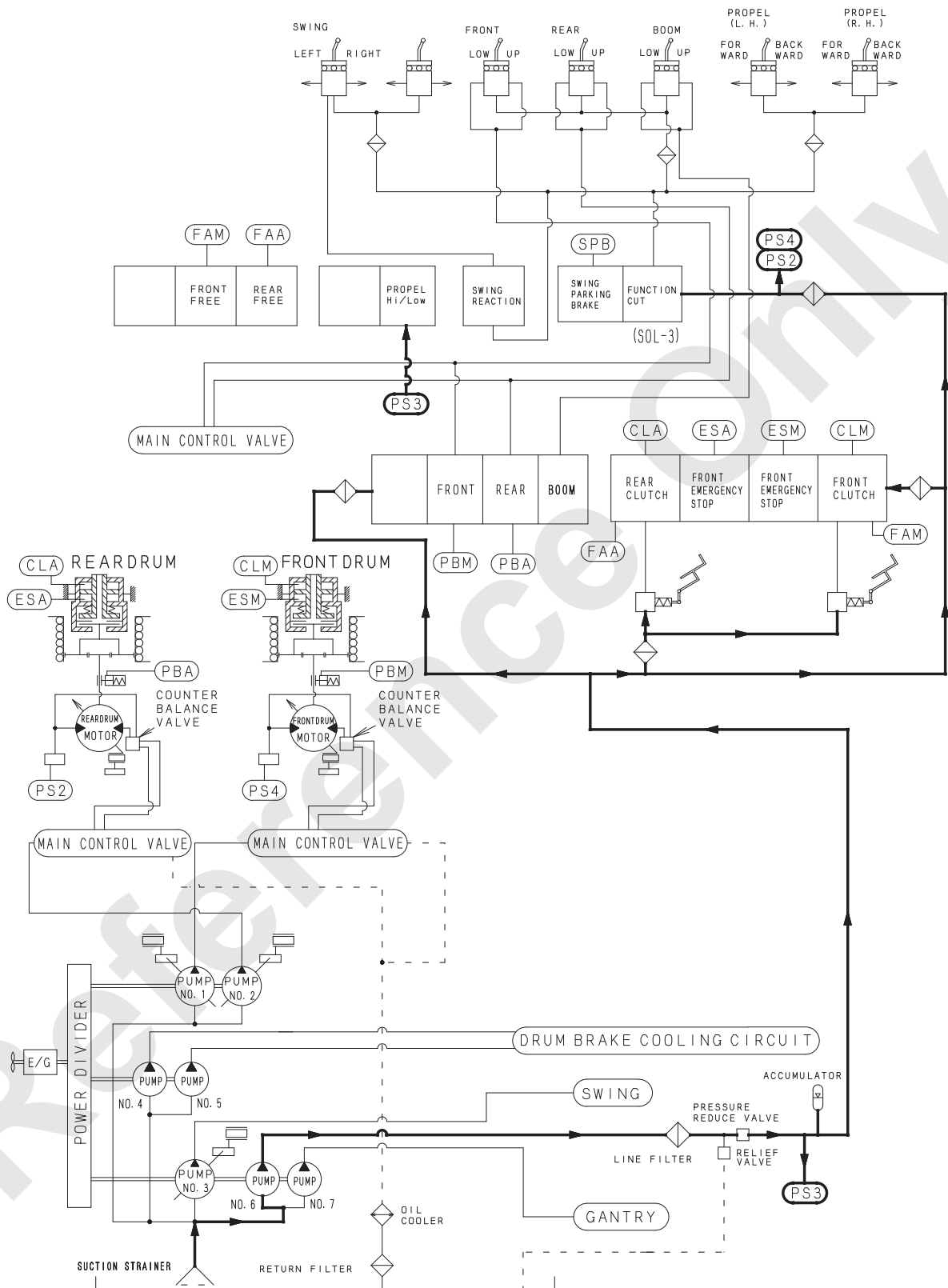

2. WHEN FUNCTION LOCK LEVER IS IN "WORK" POSITION

When the function lock lever is in "WORK" position, pressurized oil sent to 2-section valve passes through the function lock (Remo-con cut) solenoid valve (SOL-3) and flows into the remote control valve.

Under this condition, when the control valve is operated, remote control pressure is sent to the main control valve and make each actuator functioned.

Reference Only

OIL FLOW FROM No.6 PUMP (WHEN FUNCTION LOCK LEVER IS IN "WORK" POSITION)

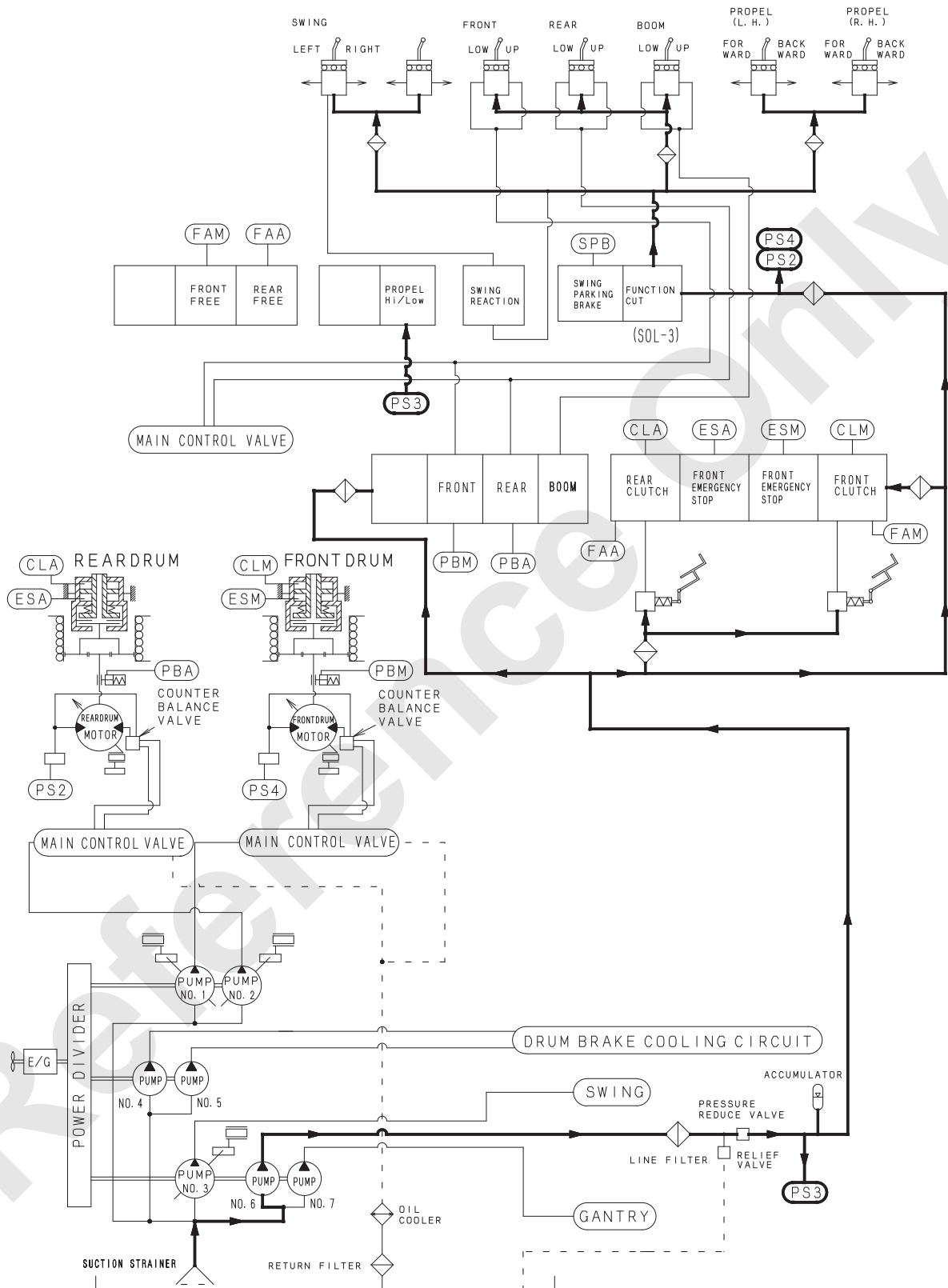

5. HYDRAULIC SYSTEM

5.3.7 OIL FLOW FROM No.7 PUMP

1. CRAWLER EXTENDING CYLINDER

No.7 pump (Aux. device pump) is fixed displacement gear pump and is used for crawler extending cylinder.

When the lower pressure source valve located in the downstream side of the gantry hoist control valve is operated, the pressurized oil from the pump passes through the swivel joint and flows into the crawler extending valve.

When the crawler extending cylinder is being operated, return oil from the cylinder passes through the swivel joint and returns to the tank.

OIL FLOW FROM No.7 PUMP (CRAWLER EXTENDING CYLINDER)

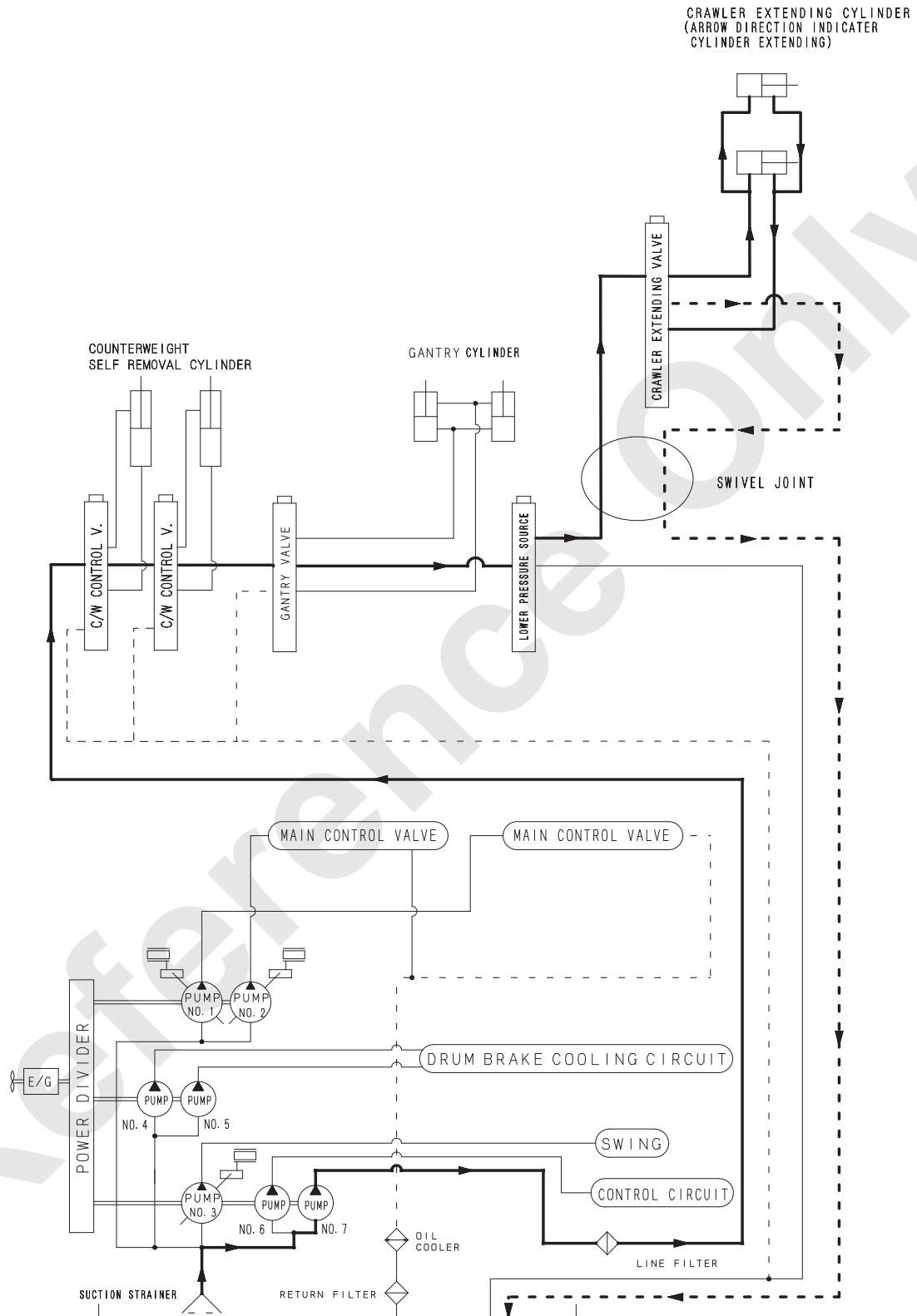

5. HYDRAULIC SYSTEM

2. TRANSLIFTER

No.7 pump (Aux. device pump) is fixed displacement gear pump and is used for the translifter cylinder.

When the lower pressure source valve located in the downstream side of the gantry hoist control valve is operated, the pressurized oil from the pump passes through the swivel joint and flows into the translifter valve.

When the translifter cylinder is being operated, return oil from the cylinder passes through the swivel joint and returns to the tank.

Reference Only

OIL FLOW FROM No.7 PUMP (TRANSLIFTER)

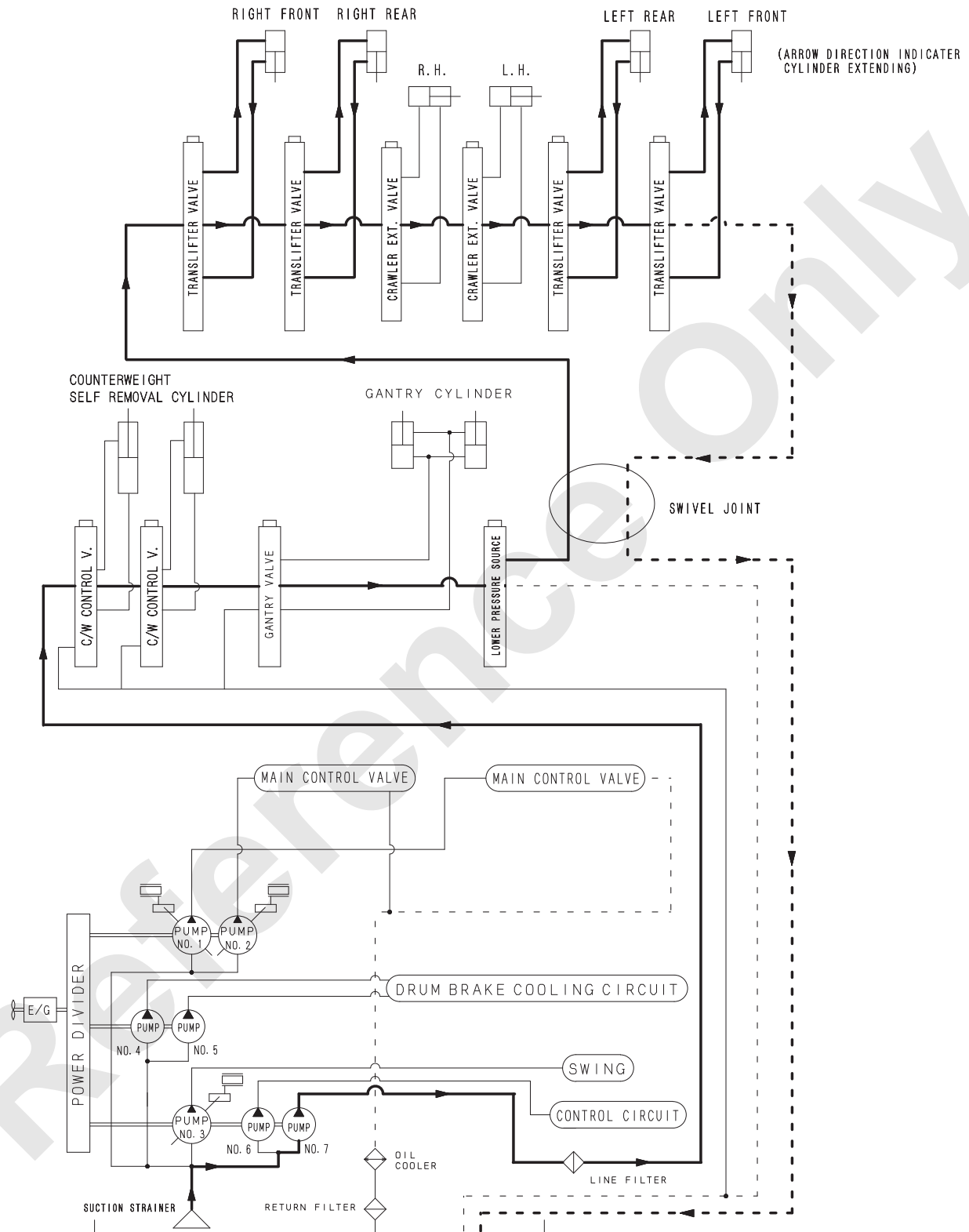

5. HYDRAULIC SYSTEM

3. GANTRY HOIST CYLINDER

No.7 pump (Aux. device pump) is fixed displacement gear pump and is used for gantry hoist. The pressurized oil from the pump flows into the gantry hoist control valve.

When the gantry hoist control valve is in neutral, the pressurized oil passes through the valve and returns to the tank without load.

Reference Only

OIL FLOW FROM No.7 PUMP (GANTRY HOIST CYLINDER)

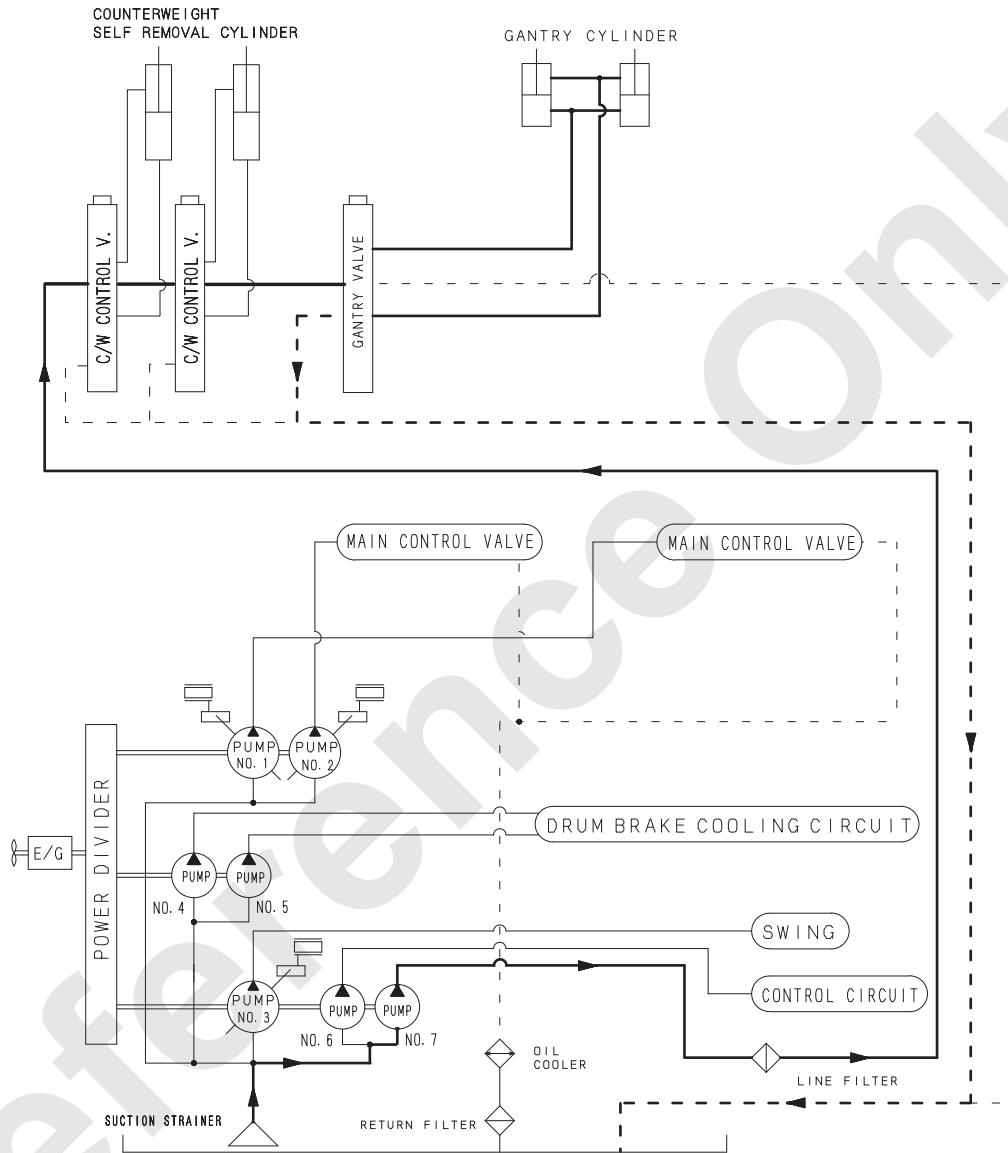

5. HYDRAULIC SYSTEM

4. COUNTERWEIGHT SELF REMOVAL CYLINDER

No.7 pump (Aux. device pump) is fixed displacement gear pump and is used for counterweight self removal.

The pressurized oil from the pump flows into the counterweight self removal control valve. When the counterweight self removal control valve is in neutral, the pressurized oil passes through the valve and returns to the tank without load.

Reference Only

OIL FLOW FROM No.7 PUMP (COUNTERWEIGHT SELF REMOVAL CYLINDER)

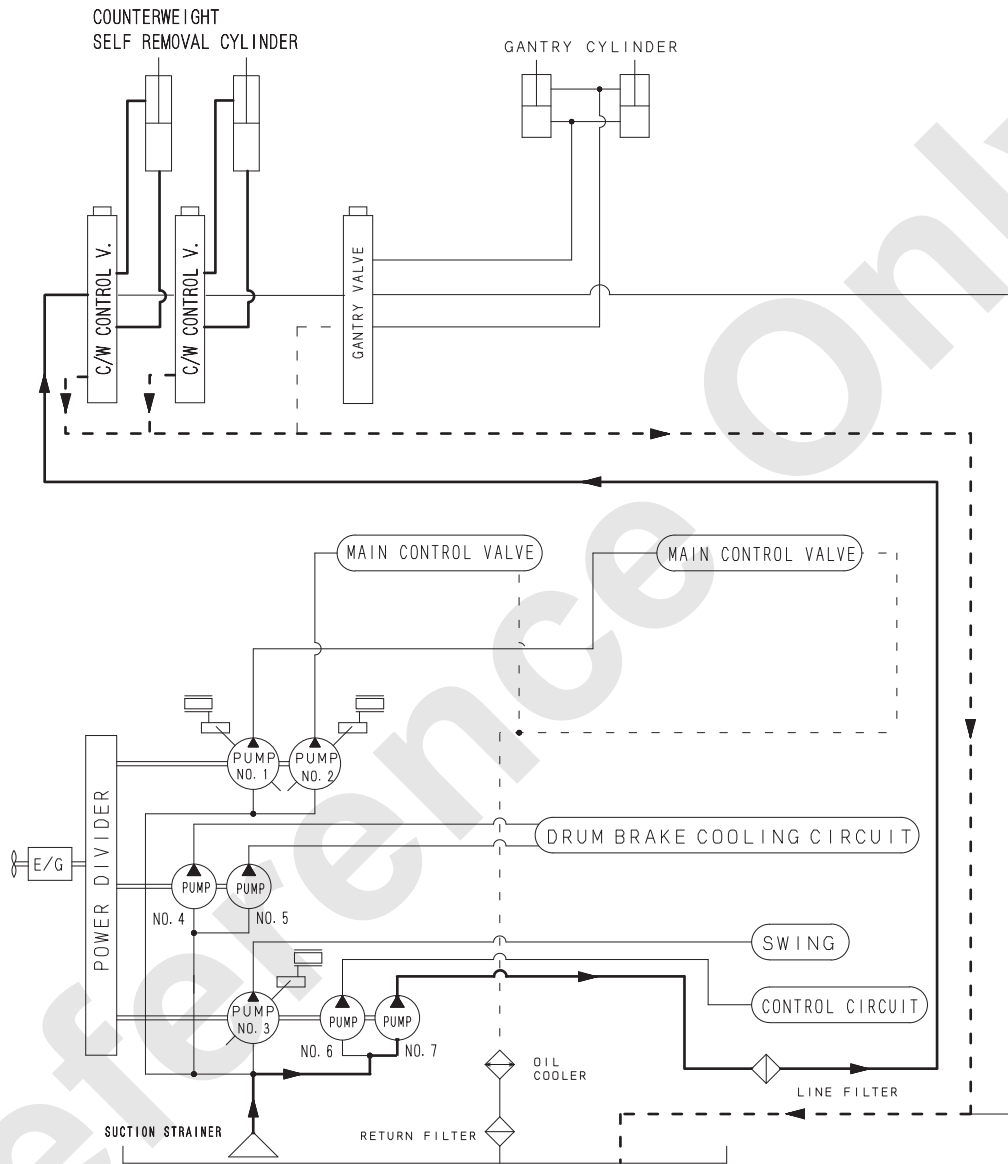

5. HYDRAULIC SYSTEM

5.4 VALVE

4-SECTION VALVE

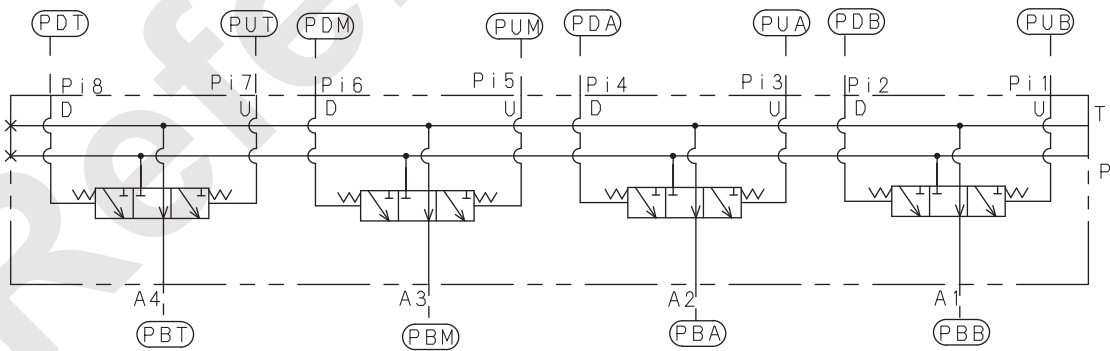
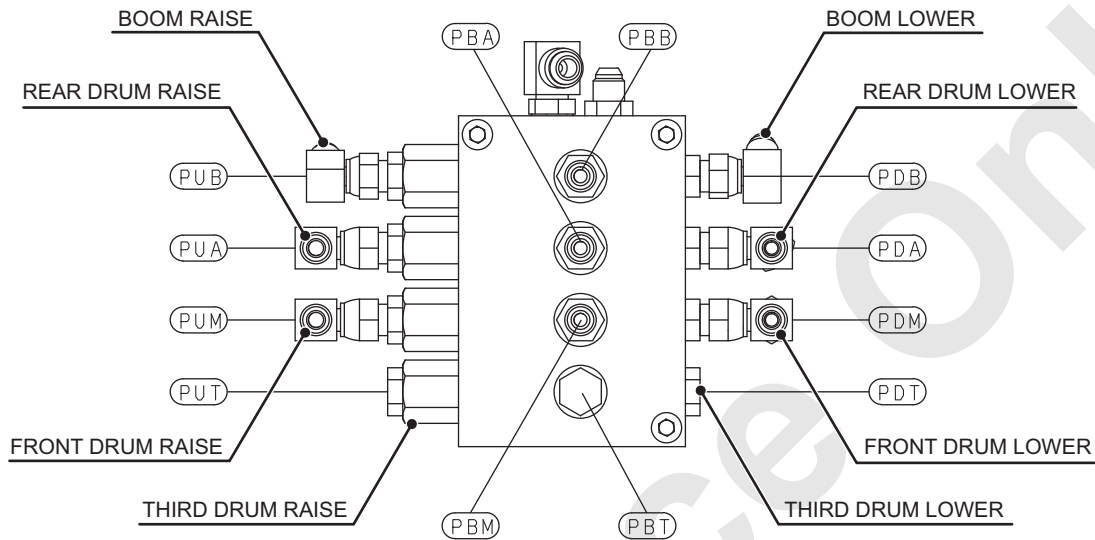

8-SECTION VALVE (WITH SHUTTLE VALVE)

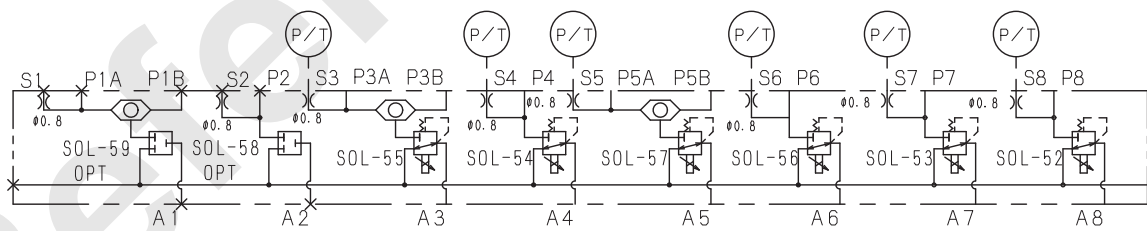
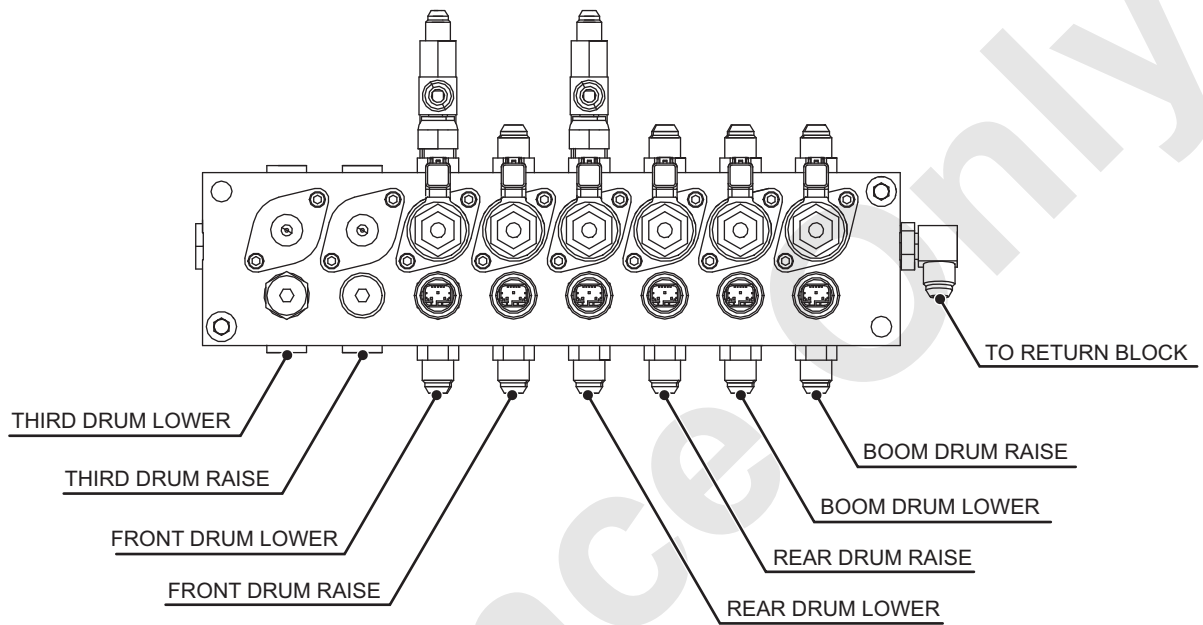

5. HYDRAULIC SYSTEM

4-SECTION VALVE

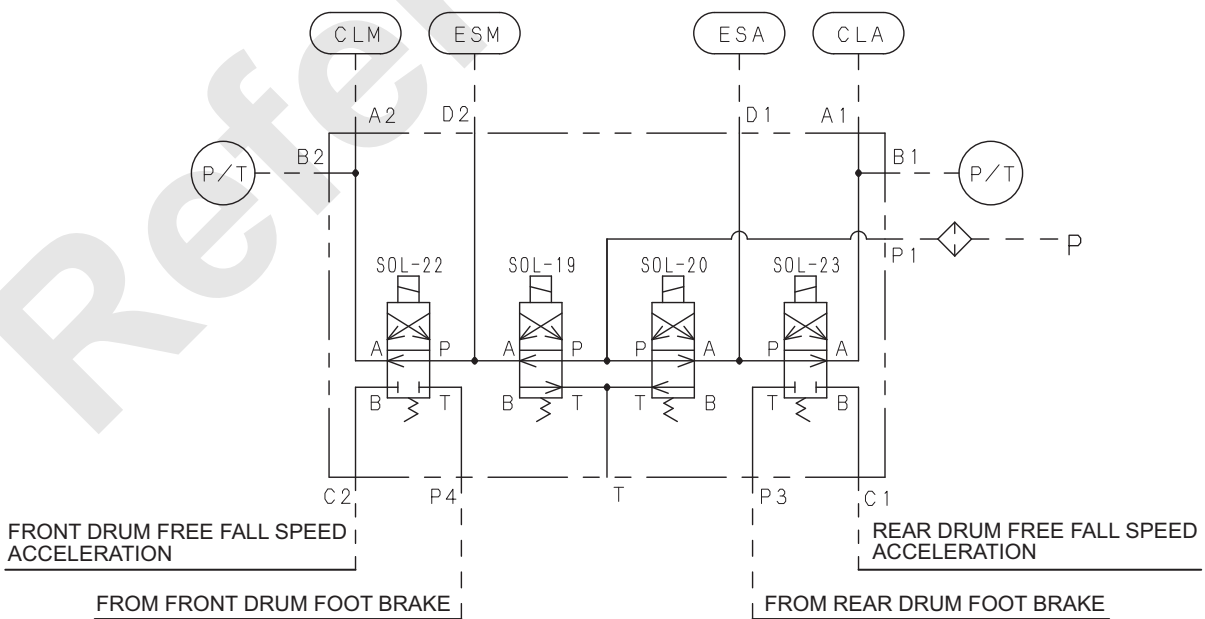
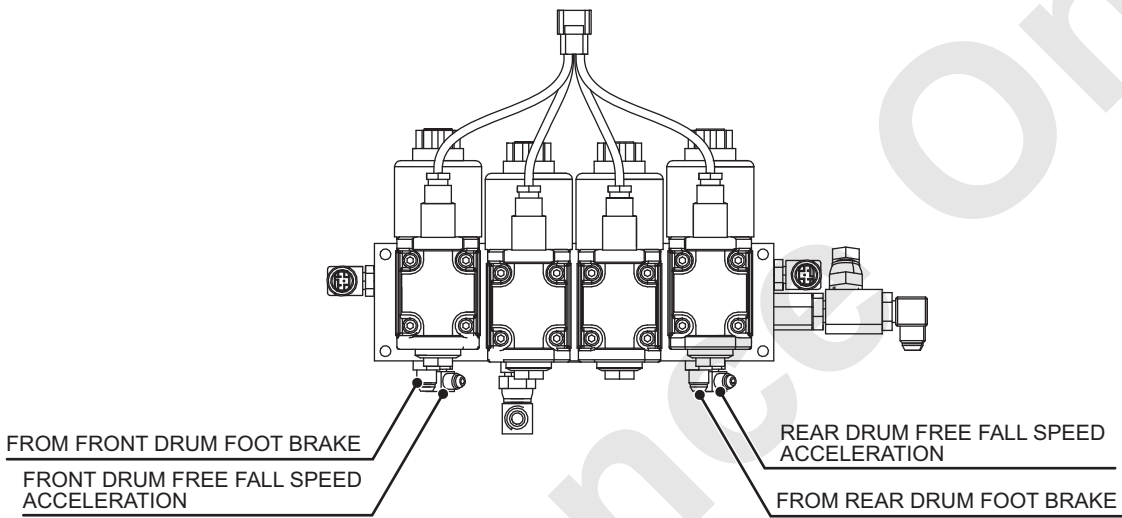
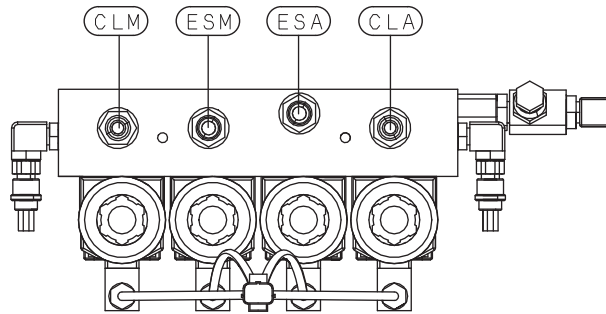

3-SECTION VALVE

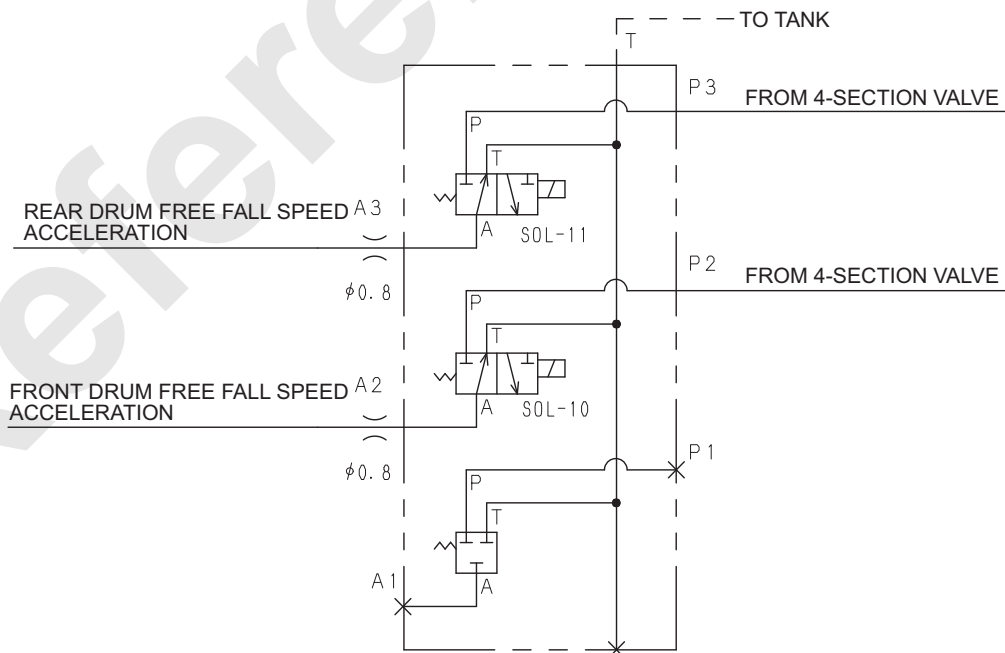
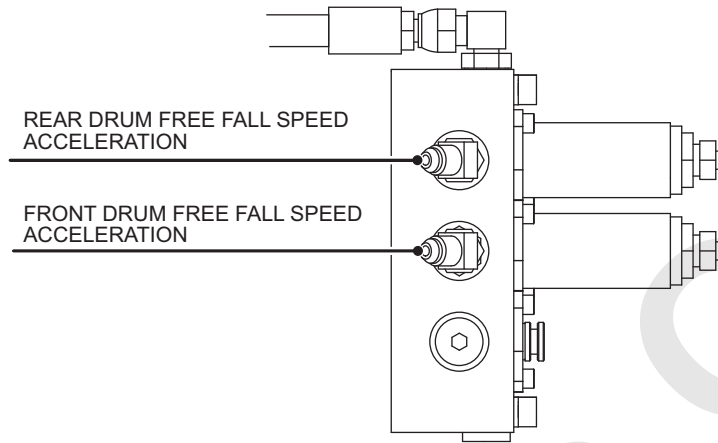

5. HYDRAULIC SYSTEM

5-SECTION VALVE

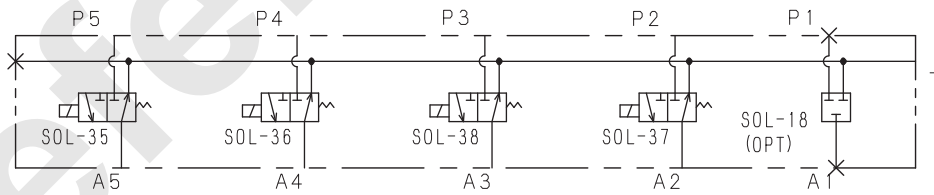
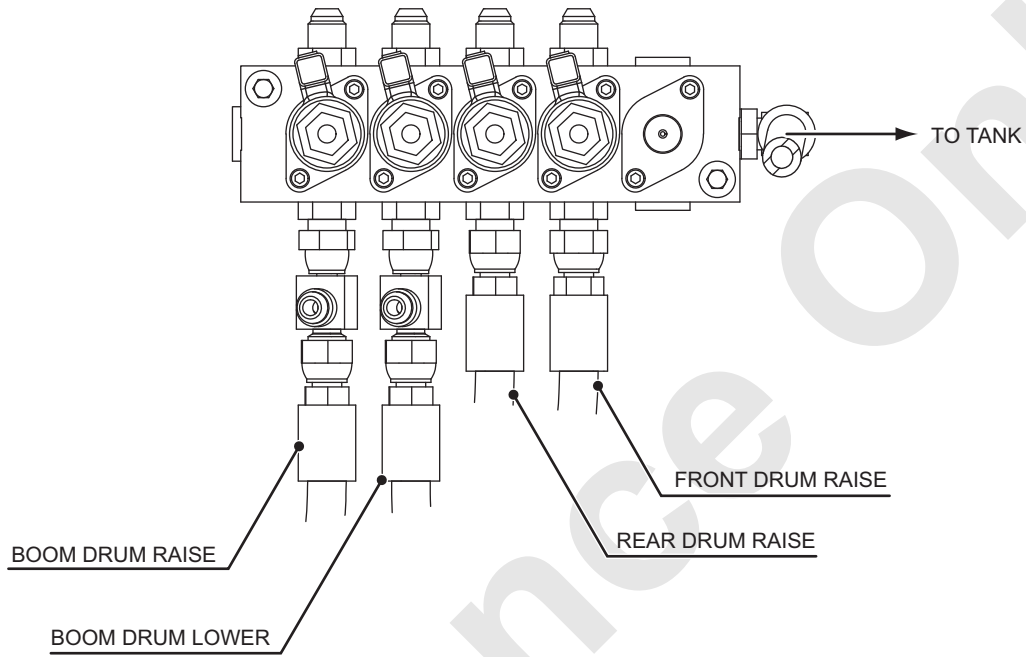

2-SECTION VALVE

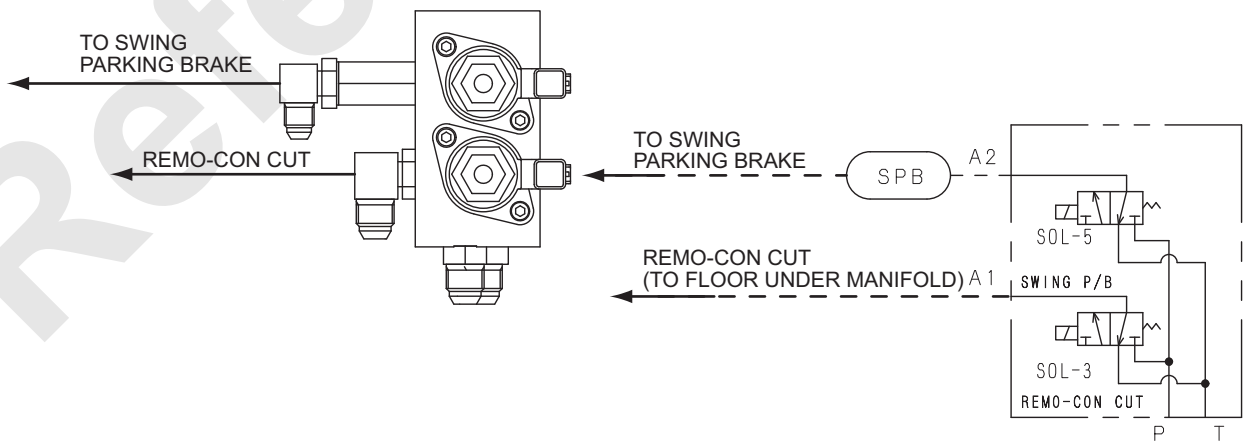
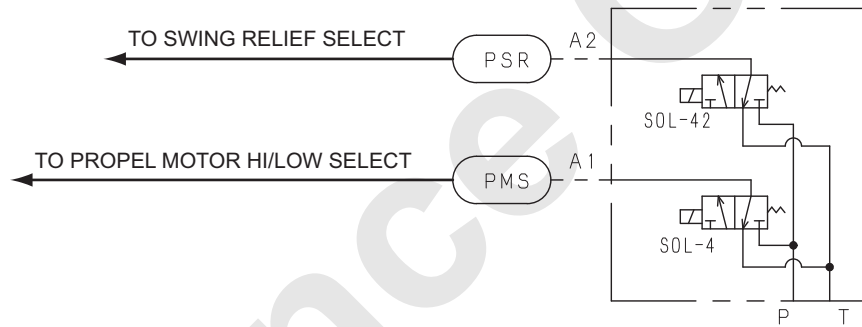
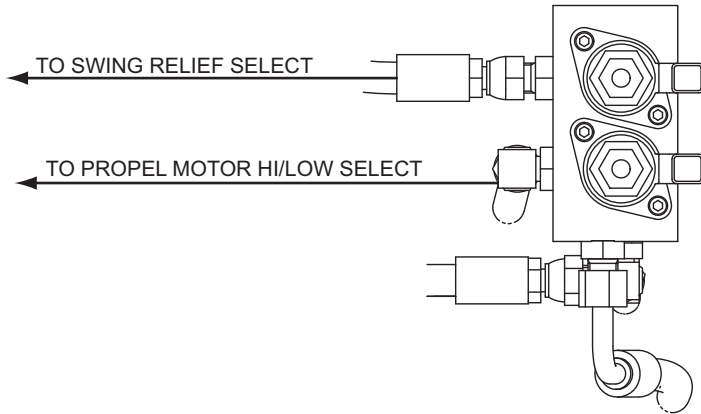

5. HYDRAULIC SYSTEM

1-SECTION VALVE

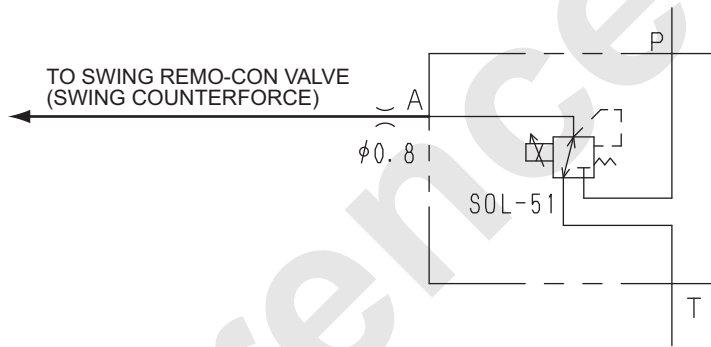
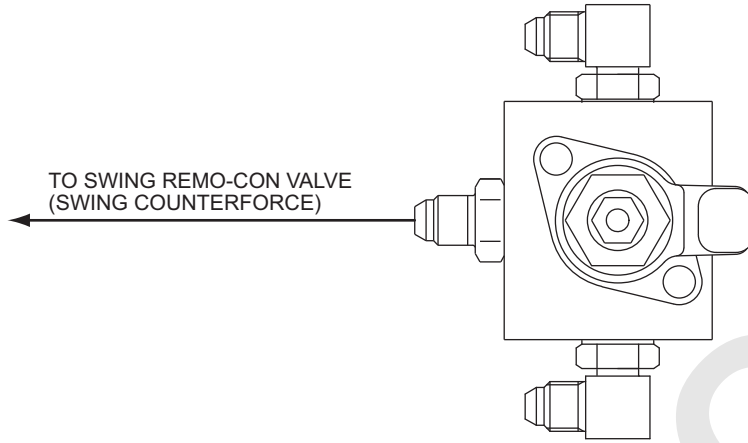

MAIN CONTROL VALVE (4-SECTION)

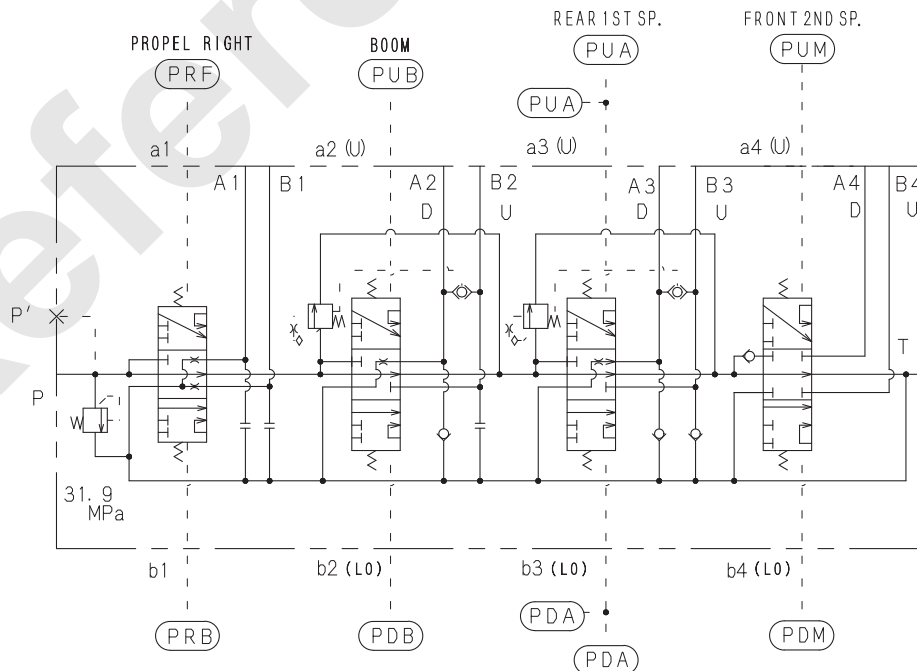
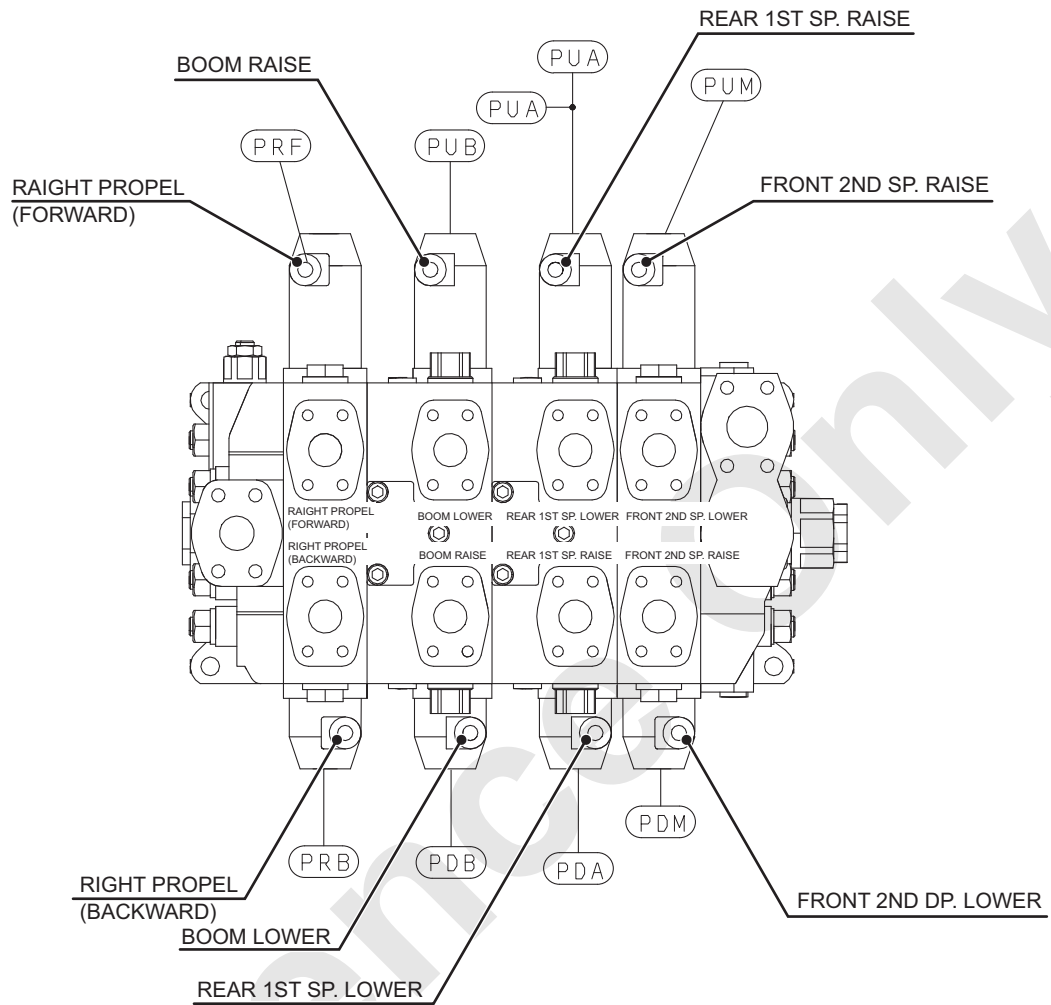

5. HYDRAULIC SYSTEM

MAIN CONTROL VALVE (3-SECTION)

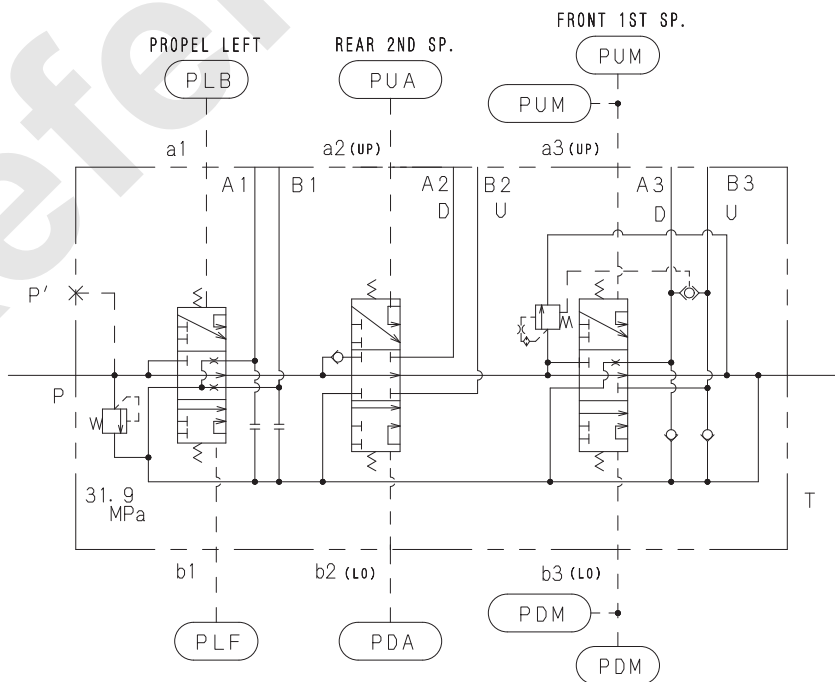
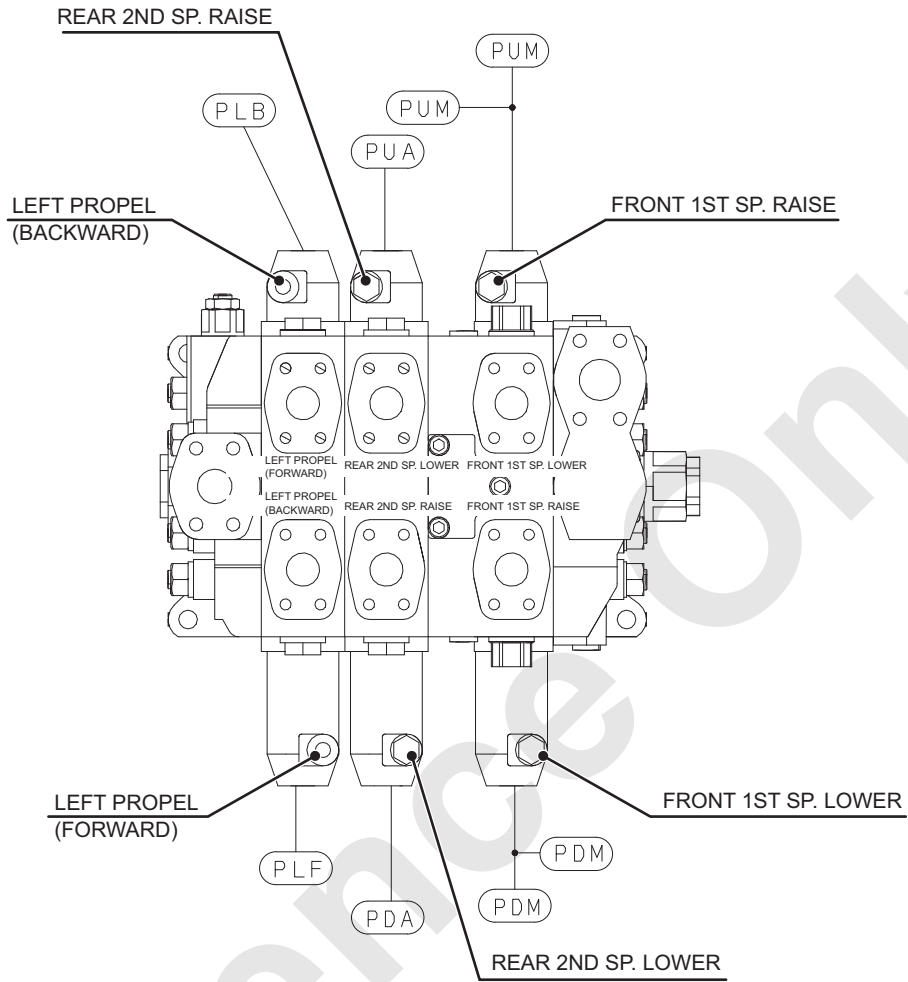

MAIN CONTROL VALVE (THIRD 1-SECTION)

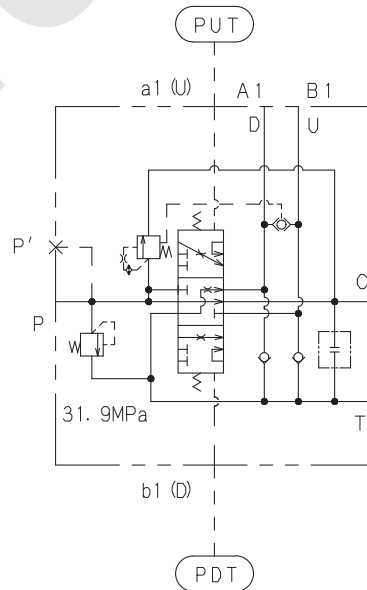
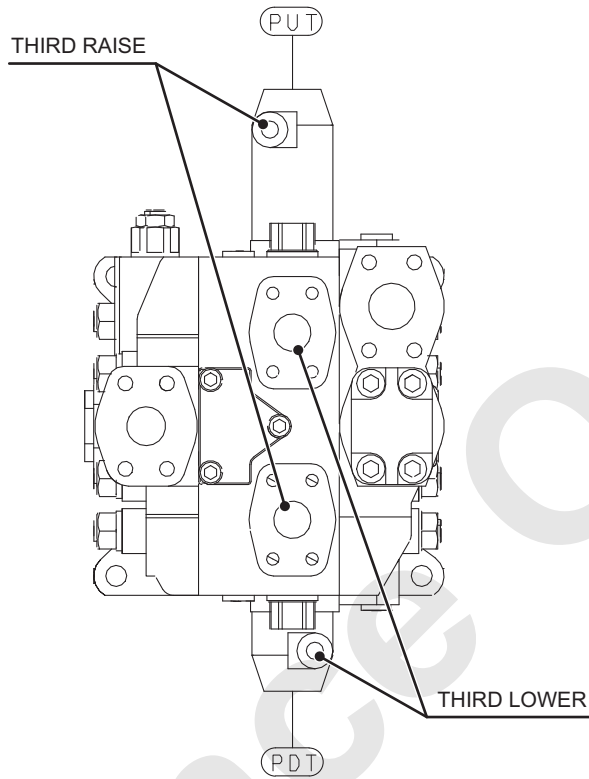

Reference Only

6. HOIST SYSTEM

Reference Only

Reference Only

6.1 APPARATUS AND LOCATION OF COMPONENTS

The hoist system consists of the front drum and rear drum assembly.

Each drum assy. consists of hoist motor (brake built in), reduction unit, drum clutch (common to free fall brake) and drum lock.

The pressured oil delivered from 2 main pumps (No.1, No.2) is controlled by the control valve and flows into each motor.

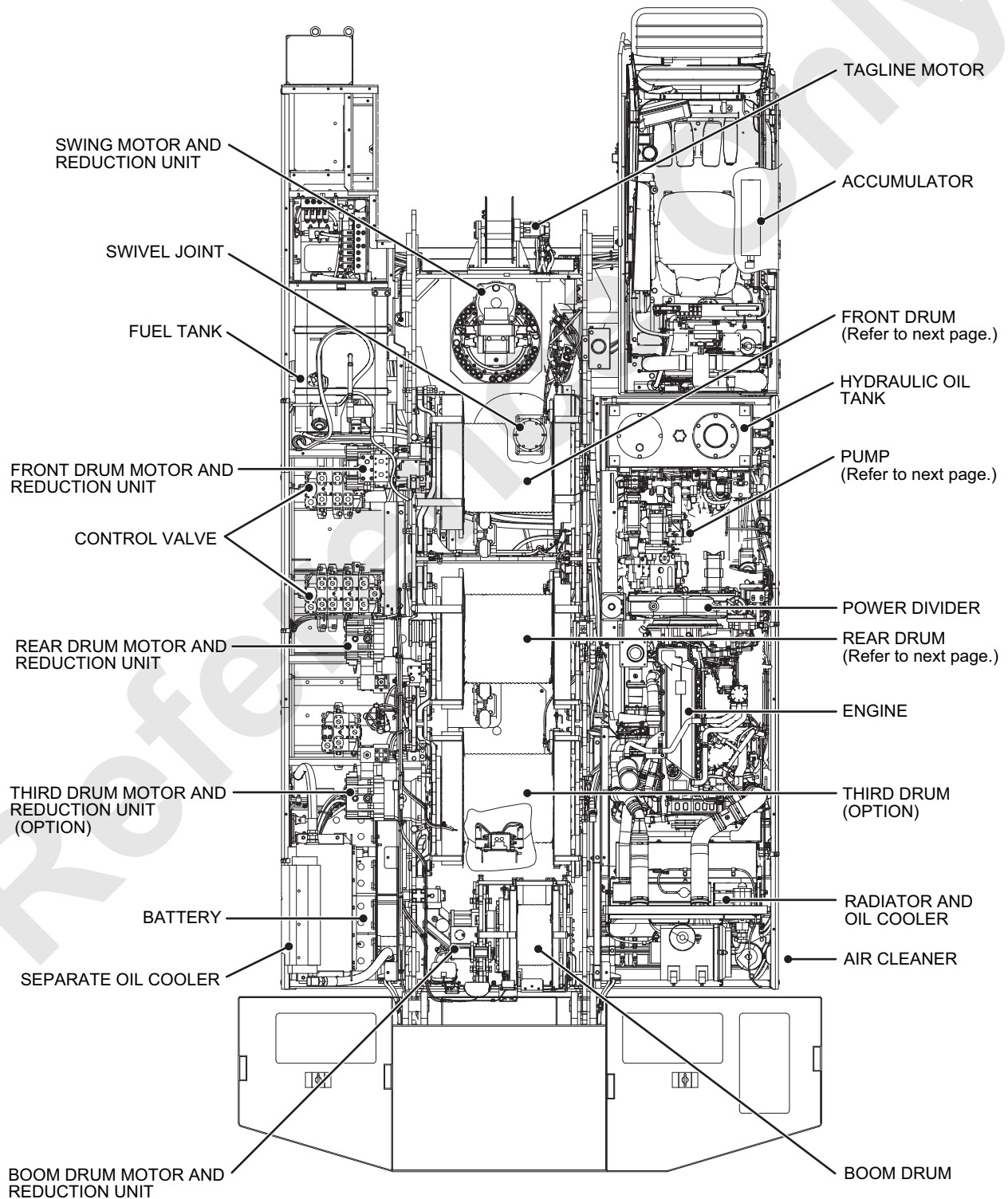

6. HOIST SYSTEM

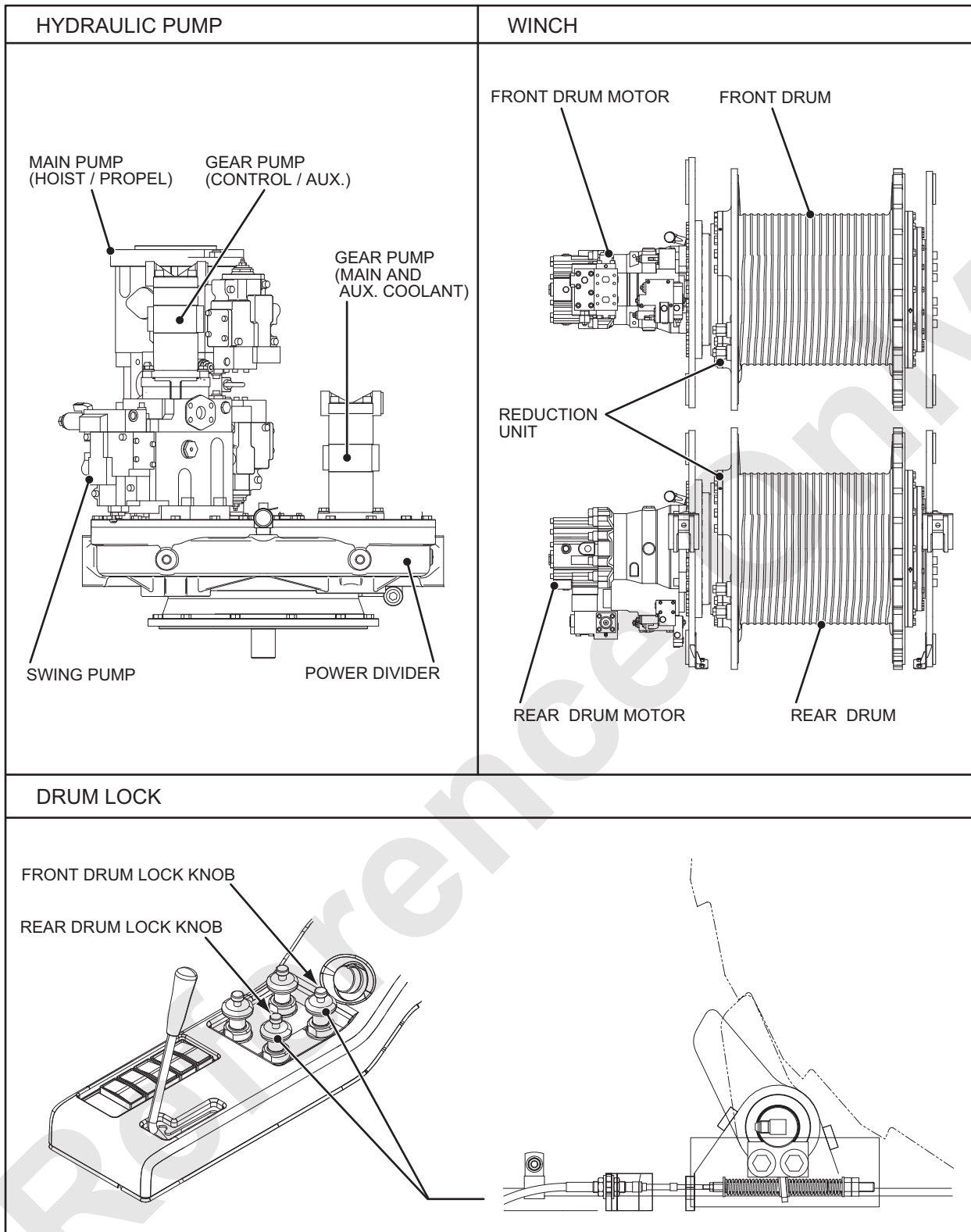

CAUTION

Refer to P.6-17 to 6-40 for circuit diagram and function.

6.2 ADJUSTMENT OF DRUM LOCK

WARNING

Do not adjust the drums locks until the boom, hook block, and load have been lowered to the ground. Failure to observe this precaution may result in serious injury or loss of life.

1. Pull the drum lock knob in the LOCK position and check to see that the pawl is engaged in the bottom of the drum ratchet.
If the pawl is not engaged in the bottom of the ratchet, adjust the spring length to allow the pawl to be engaged in the bottom.
2. With the condition of step 1., adjust the respective dimension as shown in the figure.
3. Push the drum lock knob in the RELEASE position and check to see that the pawl is clear of the ratchet by at least 20 mm (13/16 inch).
Operate the knob to the LOCK position and to the RELEASE position and confirm that the pawl moves smoothly.

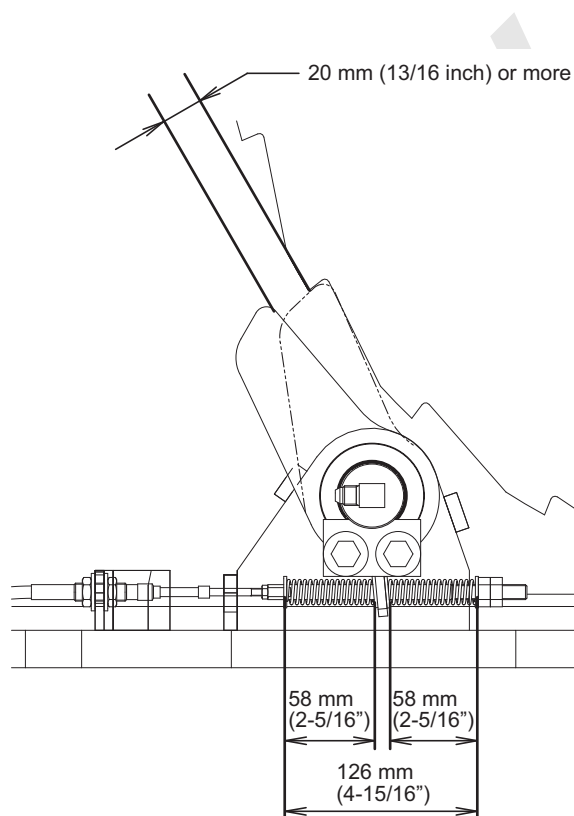

FRONT AND REAR DRUM LOCK

Refer

6. HOIST SYSTEM

6.3 WINCH

6.3.1 WINCH INSTALLATION

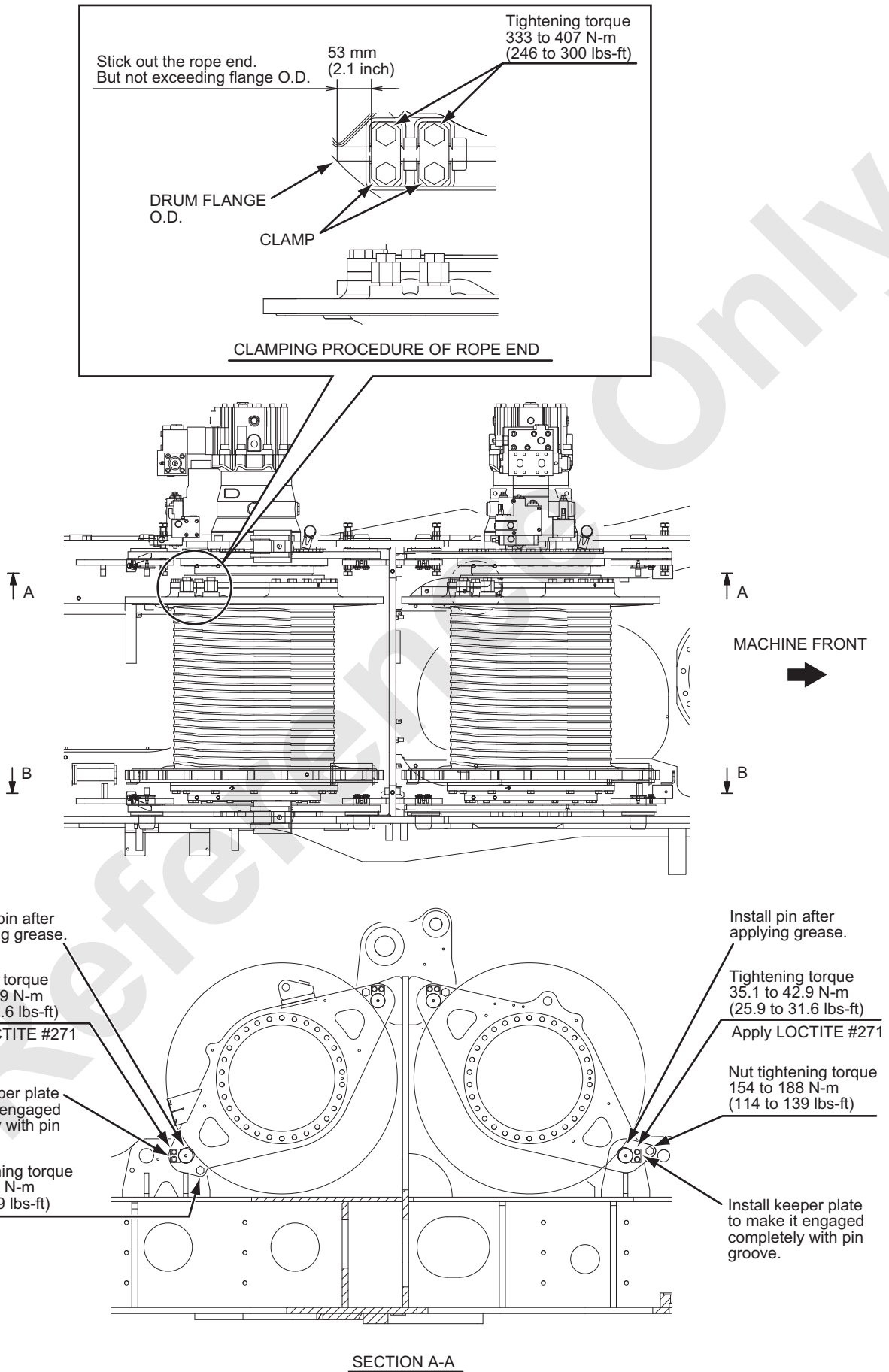

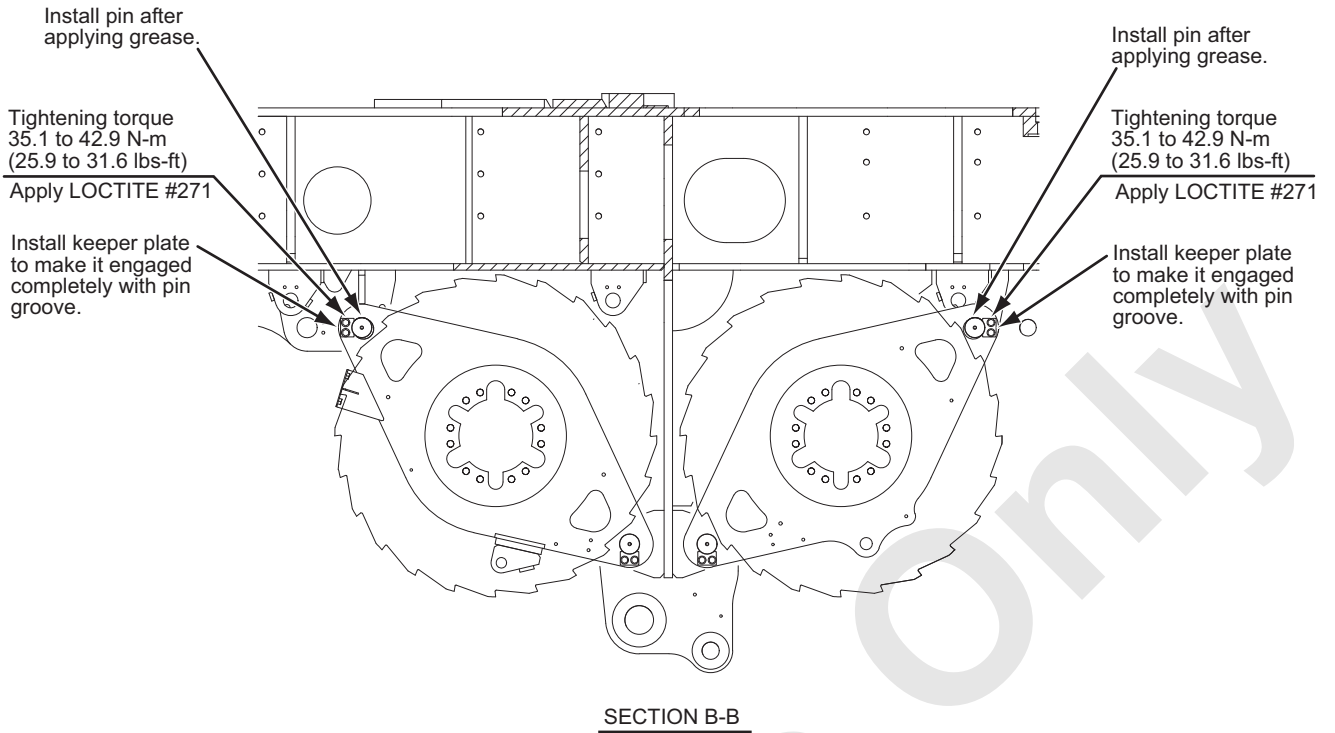

Reference Only

6. HOIST SYSTEM

6.3.2 WINCH ASSEMBLY

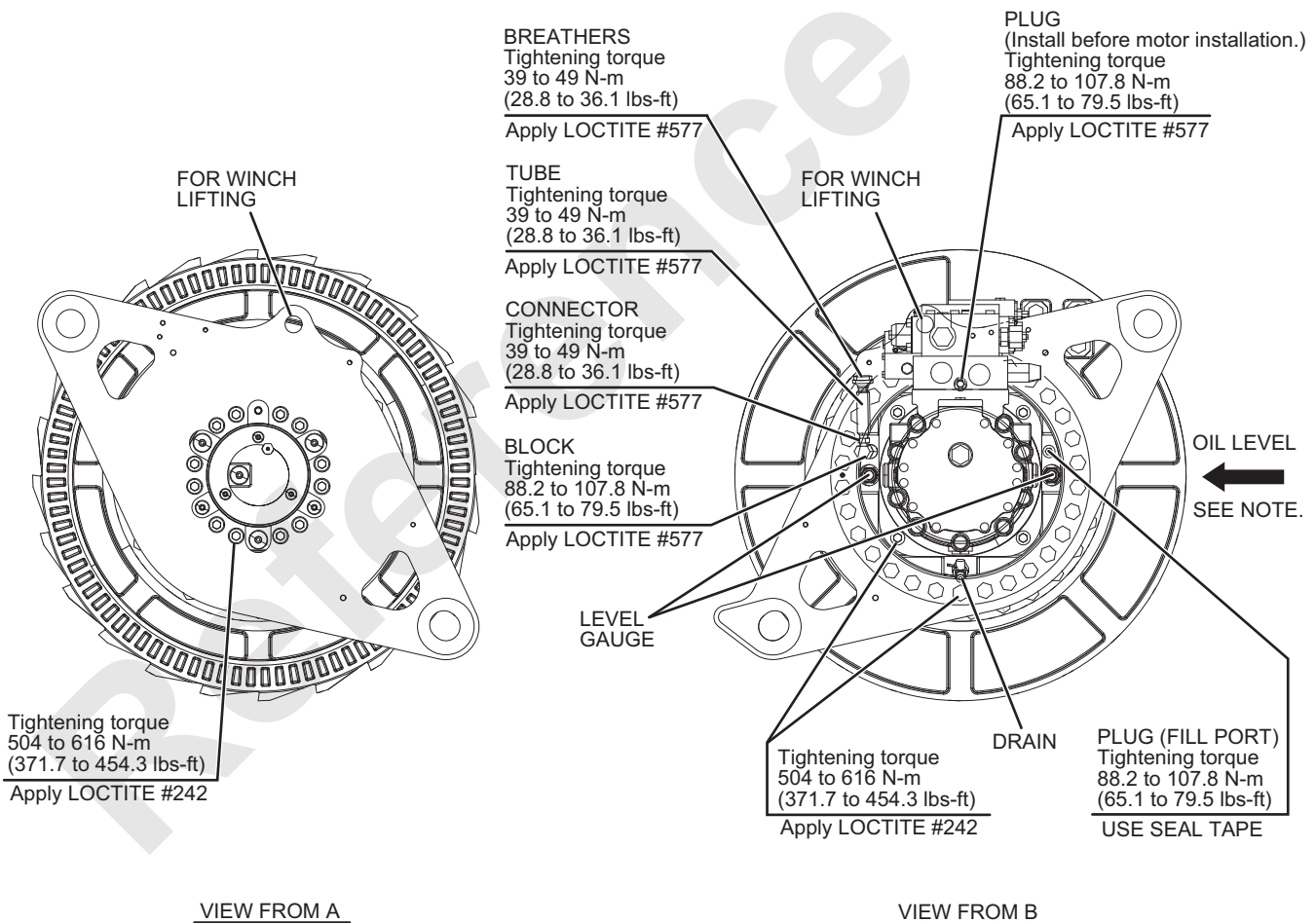
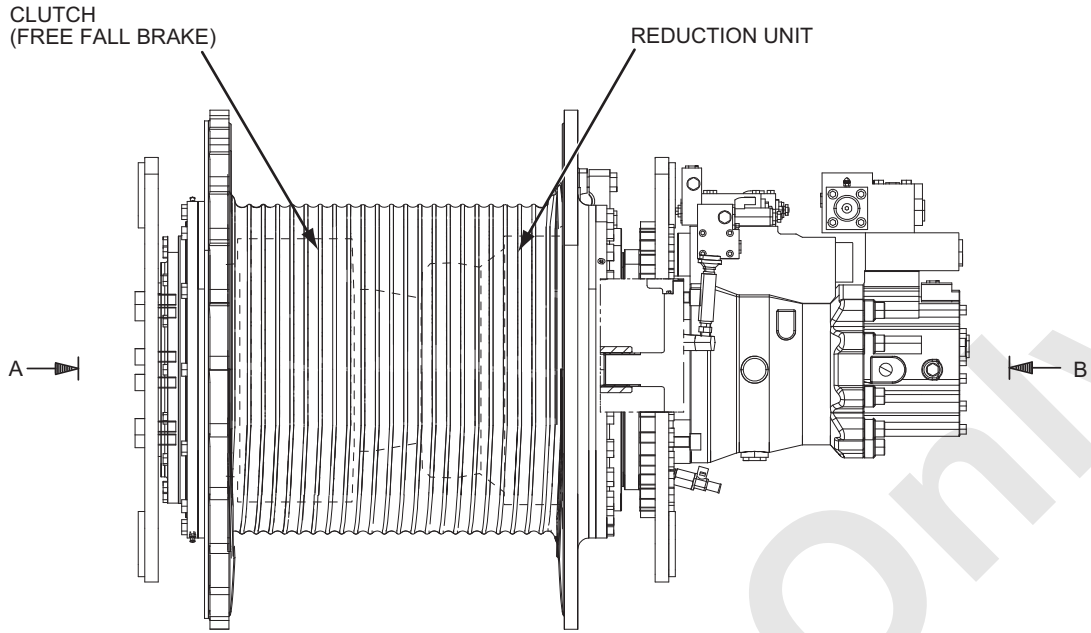

NOTE : After assembly, fill oil to the specified level. (approx. 23 ltr.)
Higher than level gauge red point and within the oil :
Extreme pressure gear oil
SAE #80W-90 (APOLOIL GEAR HE MULTI-SPECIAL).

This page is blank for editing convenience.

Reference Only

6. HOIST SYSTEM

6.3.3 REDUCTION UNIT ASSEMBLY

Apply three bond #1215 evenly on outer periphery area and apply grease lightly on lip area and assemble. Oil seal is to be hit with hammer etc.

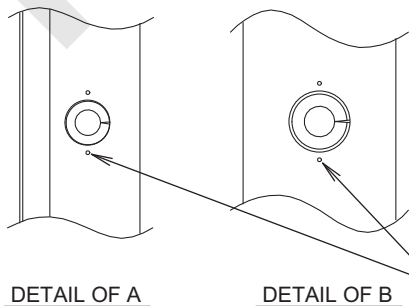
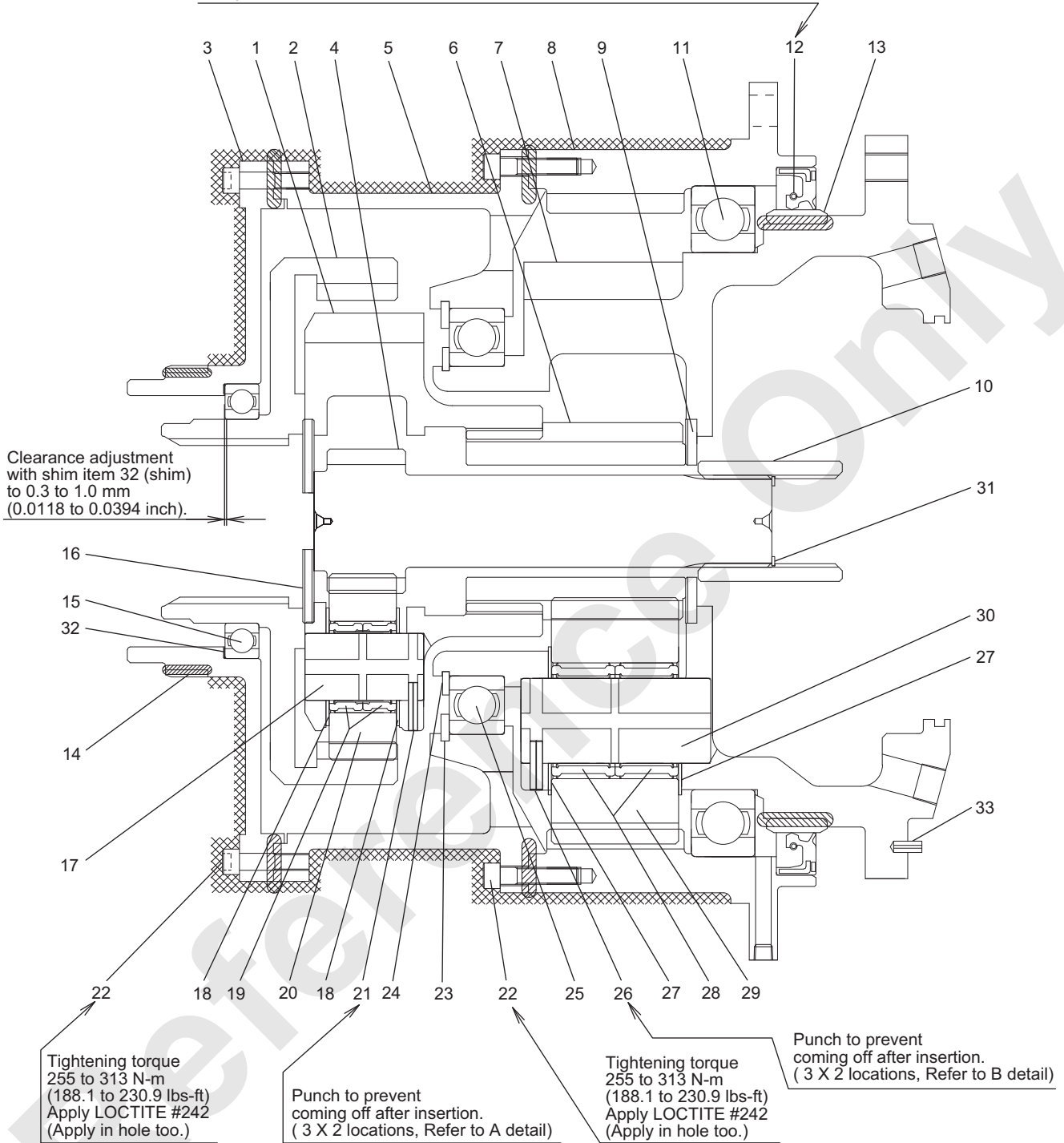

NOTE

1. On mating surface, apply loctite #515 on inner face of sleeve and both of outer periphery surfaces of the press fit in assembling.
2. Apply 1 coat painting before winch drum is installed. But except machining face. As for paint and film thickness, follow KS52M6050. D0003.
3. After assembling is completed, press the 1st sun gear into the reduction unit by tapping it lightly and confirm that it turns easily.

PUNCHING POINT

- | | | |
|--------------------|-------------------|-------------------|
| 1. Carrier | 12. Oil seal | 23. Snap ring |
| 2. Gear ring | 13. Sleeve | 24. Snap ring |
| 3. Retainer | 14. Sleeve | 25. Bearing |
| 4. Sun gear | 15. Bearing | 26. Spring pin |
| 5. Support housing | 16. Spacer | 27. Thrust washer |
| 6. Sun gear | 17. Pin | 28. Bearing |
| 7. Support | 18. Thrust washer | 29. Pinion |
| 8. Ring gear | 19. Bearing | 30. Pin |
| 9. Spacer | 20. Pinion | 31. Snap ring |
| 10. Collar | 21. Spring pin | 32. Shim |
| 11. Bearing | 22. Bolt | 33. Pin |

Reference Only

6. HOIST SYSTEM

6.4 BRAKE PEDAL

6.4.1 ASSEMBLY DRAWING

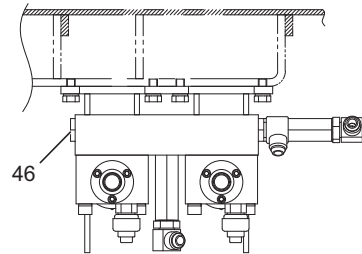
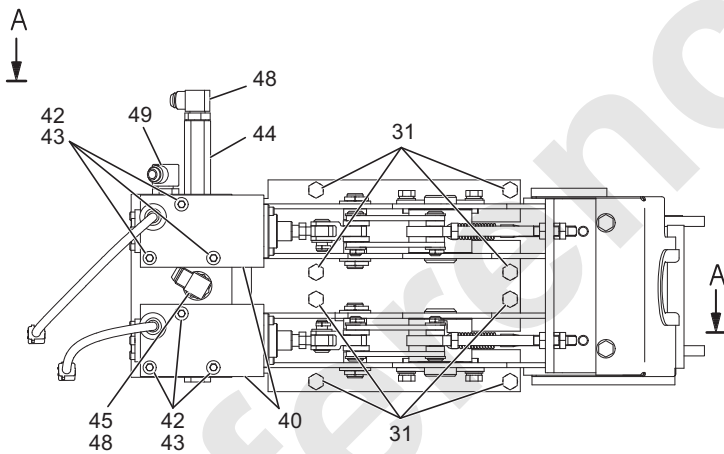
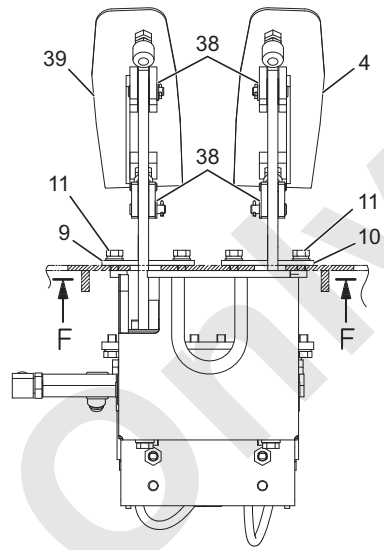
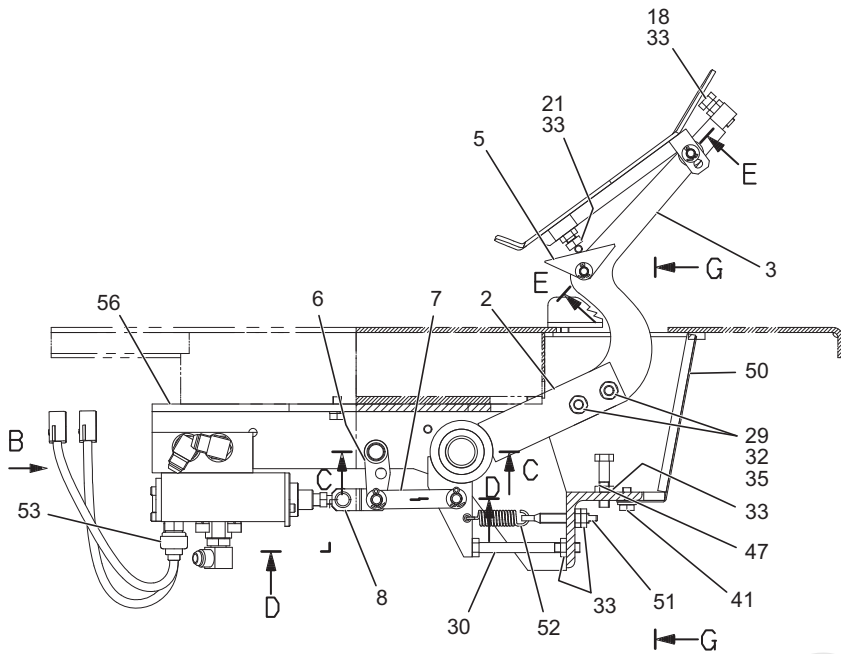

VIEW FROM B

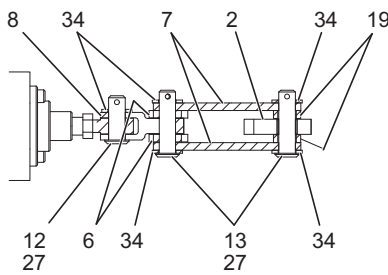
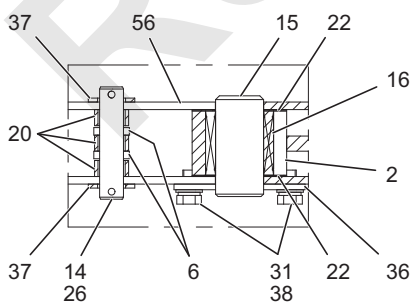

SECTION D-D

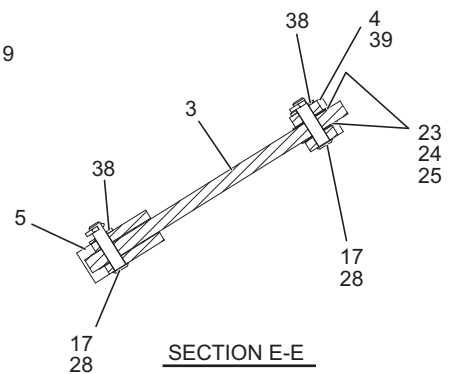

SECTION E-E

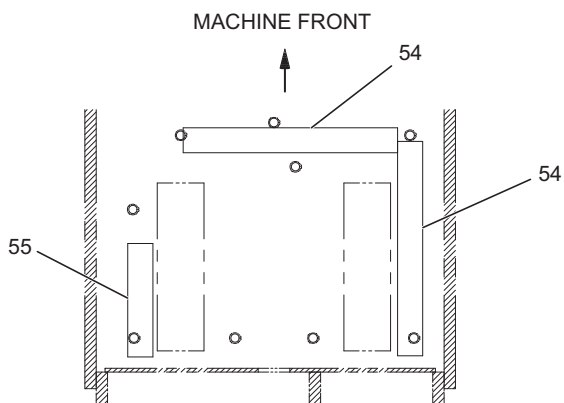

SECTION F-F

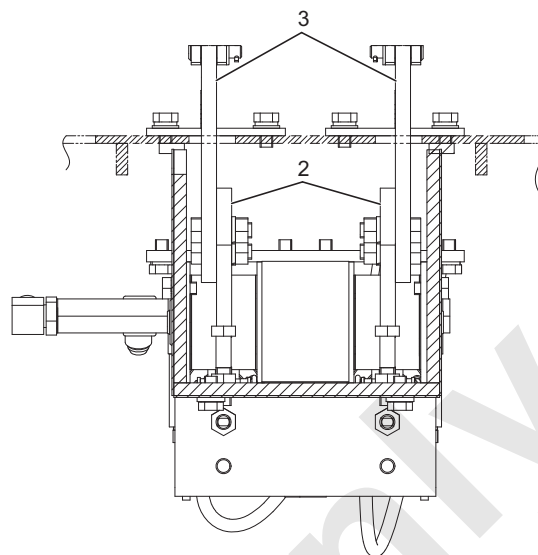

SECTION G-G

- | | | |
|-------------------|-----------------|----------------------|
| 1. Bracket | 20. Spacer | 39. Pedal |
| 2. Lever assembly | 21. Bolt | 40. Brake valve |
| 3. Link | 22. Spacer | 41. Sems bolt |
| 4. Pedal | 23. Shim (0.4) | 42. Capscrew |
| 5. Pawl | 24. Shim (0.6) | 43. Lock washer |
| 6. Link | 25. Shim (0.9) | 44. Connector |
| 7. Link | 26. Cotter pin | 45. Connector |
| 8. Link | 27. Cotter pin | 46. Plug |
| 9. Bracket | 28. Cotter pin | 47. Capscrew |
| 10. Bracket | 29. Bolt | 48. 90 degrees Elbow |
| 11. Sems bolt | 30. Bolt | 49. 90 degrees Elbow |
| 12. Pin | 31. Sems bolt | 50. Cover assembly |
| 13. Pin | 32. Nut | 51. Eye bolt |
| 14. Pin | 33. Nut | 52. Spring |
| 15. Pin | 34. Washer | 53. Pressure switch |
| 16. Bearing | 35. Lock washer | 54. Rubber |
| 17. Pin | 36. Plate | 55. Rubber |
| 18. Bolt | 37. Washer | 56. Bracket |
| 19. Spacer | 38. Washer | |

TIGHTENING TORQUE TABLE

Item	Name	Size	Tightening Torque
29	Bolt	M12 X 40	37.3 to 45.1 N-m (27.5 to 33.2 lbs-ft)
42	Capscrew	M10 X 70	30.4 to 38.2 N-m (22.4 to 28.2 lbs-ft)

- When installing item 16 bearing, fill in enough amount of grease.
- Apply MOLYKOTE on each rotating area.

6. HOIST SYSTEM

6.4.2 ADJUSTING THE BRAKE PEDAL

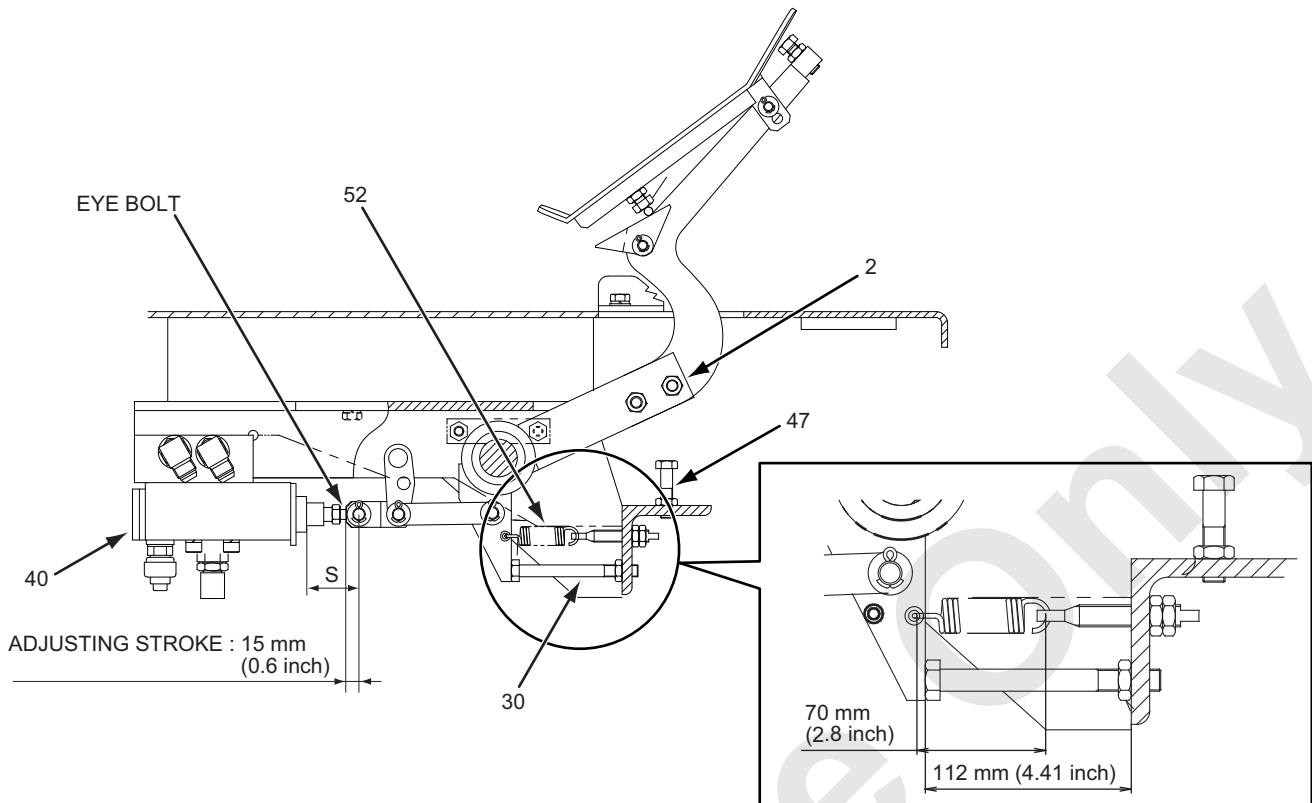

Adjustment

1. Adjust the eye bolt until the dimension S is 53 mm (2.09 inch).
2. Depress the brake pedal until the valve spool reaches the stroke end.
(dimension S = 37.5 mm (1.48 inch))
3. Bring the bolt (No.47) into contact with the lever (No.2) in the status described in the 2 above, and loosen 3/4 turn (protrude upward) to adjust the dimension S until it is 38.0 mm (1.5 inch) to 38.3 mm (1.51 inch).
Then, tighten the nut.
4. Raise the lever (No.2) up, and return the valve spool to the neutral position.
(dimension S = 53 mm (2.09 inch))
Bring the cap screw (No.30) into contact with the lever (No.2), and loosen 3/4 turn (protrude left).
Then, tighten the nut.
(dimension S = 52.3 mm (2.06 inch) to 52.5 mm (2.07 inch))
5. Adjust the spring (No.52) until the dimension L is 70 mm (2.76 inch) in the status described in the 4 above.
6. Ensure that the effective stroke of the valve (No.40) from the time when the pedal is depressed to the time it is released is 15 mm (0.6 inch).

6.5 BLEEDING AIR FROM BRAKE CIRCUIT

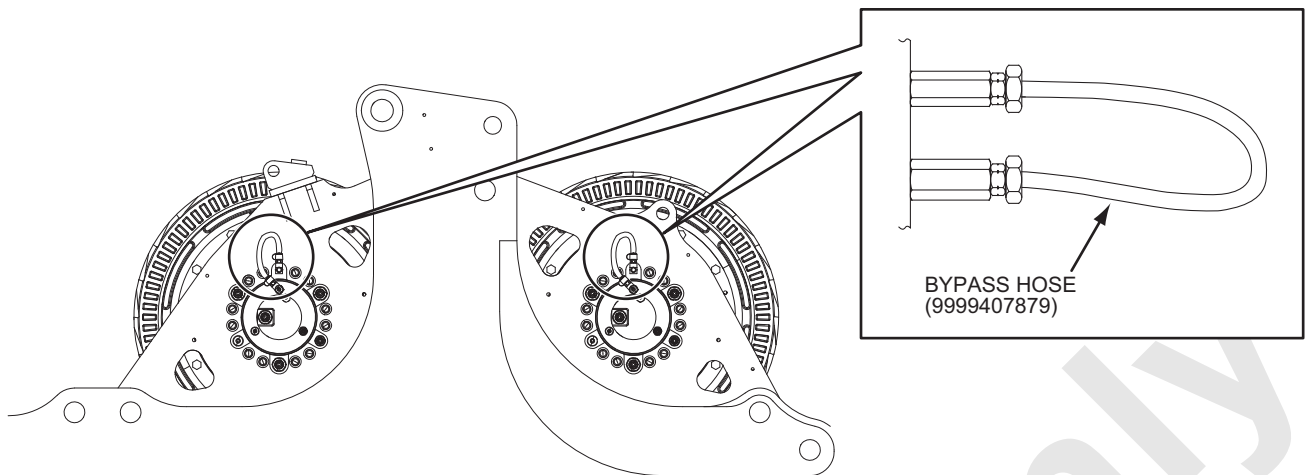

If air remains in the piping from the brake valve to the cylinder built in the winch, the brake response becomes poor.

If the brake valve and piping are removed, bleed air by the following sequences shown below.

WARNING

Be sure to lower the hook onto the ground, and select the "Neutral free" mode.

Then, ensure that the drum does not rotate even when you release your foot from the brake pedal.

1. Bypass the quick coupler of the winch brake section with a hose, while the engine is stopped.
Hose used: 9999407879
2. Start the engine, and set the engine speed to the high idling.
3. Fully depress the brake pedal, and press the brake select switch to enter the "Free fall mode".
* The free fall indicator lamp lights up.
4. Release your foot from the brake pedal, and wait for approx. 1 minute.
At this time, air bleed.
5. Return to the "Neutral brake mode", and stop the engine.
After the engine is stopped, wait until the control pressure is released (approx. 1 minute), and then, remove the bypass hose.

This page is blank for editing convenience.

6.6 CONSTRUCTION AND FUNCTION

6.6.1 HYDRAULIC SCHEMATIC

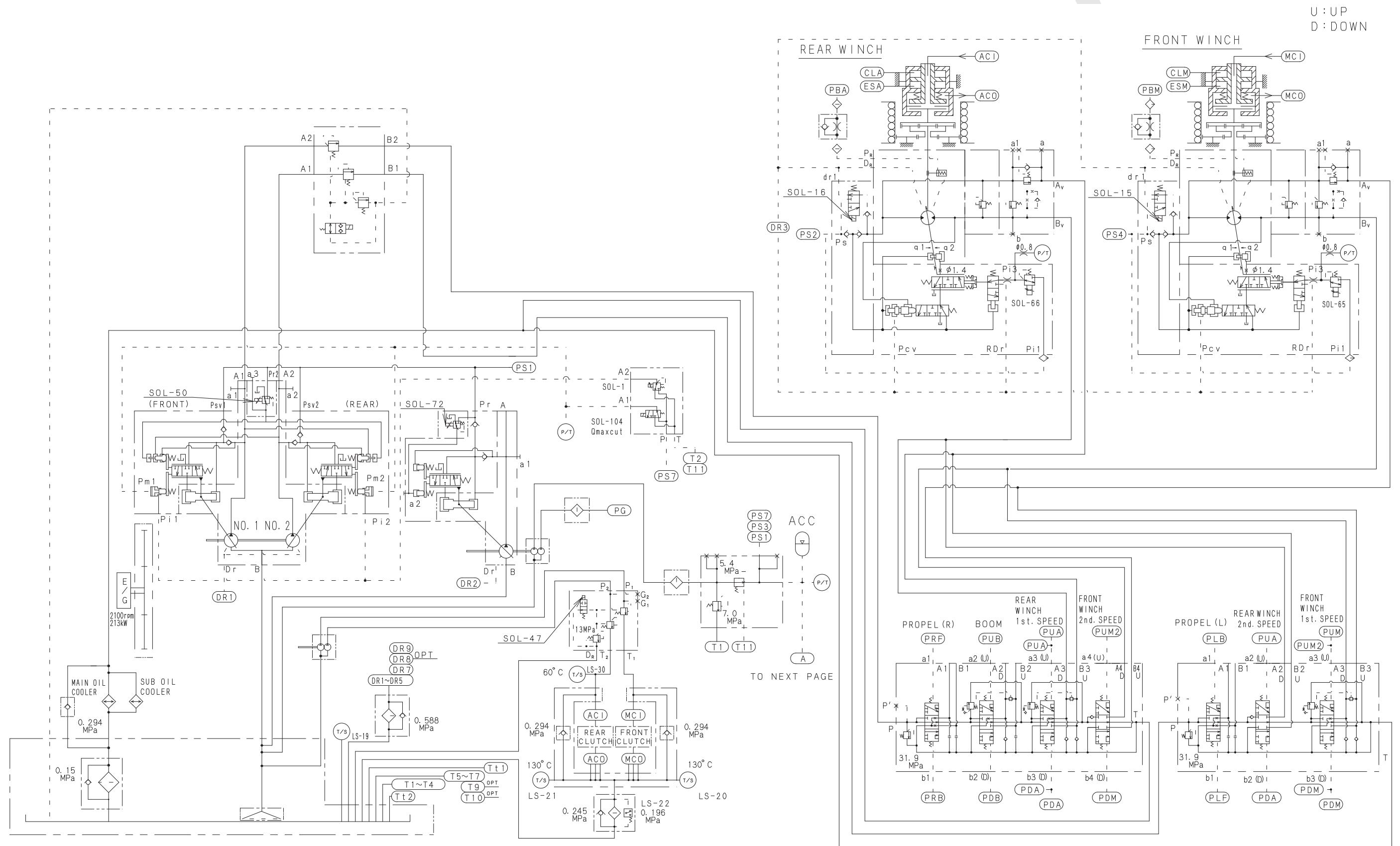

6. HOIST SYSTEM

U : UP
D : DOWN

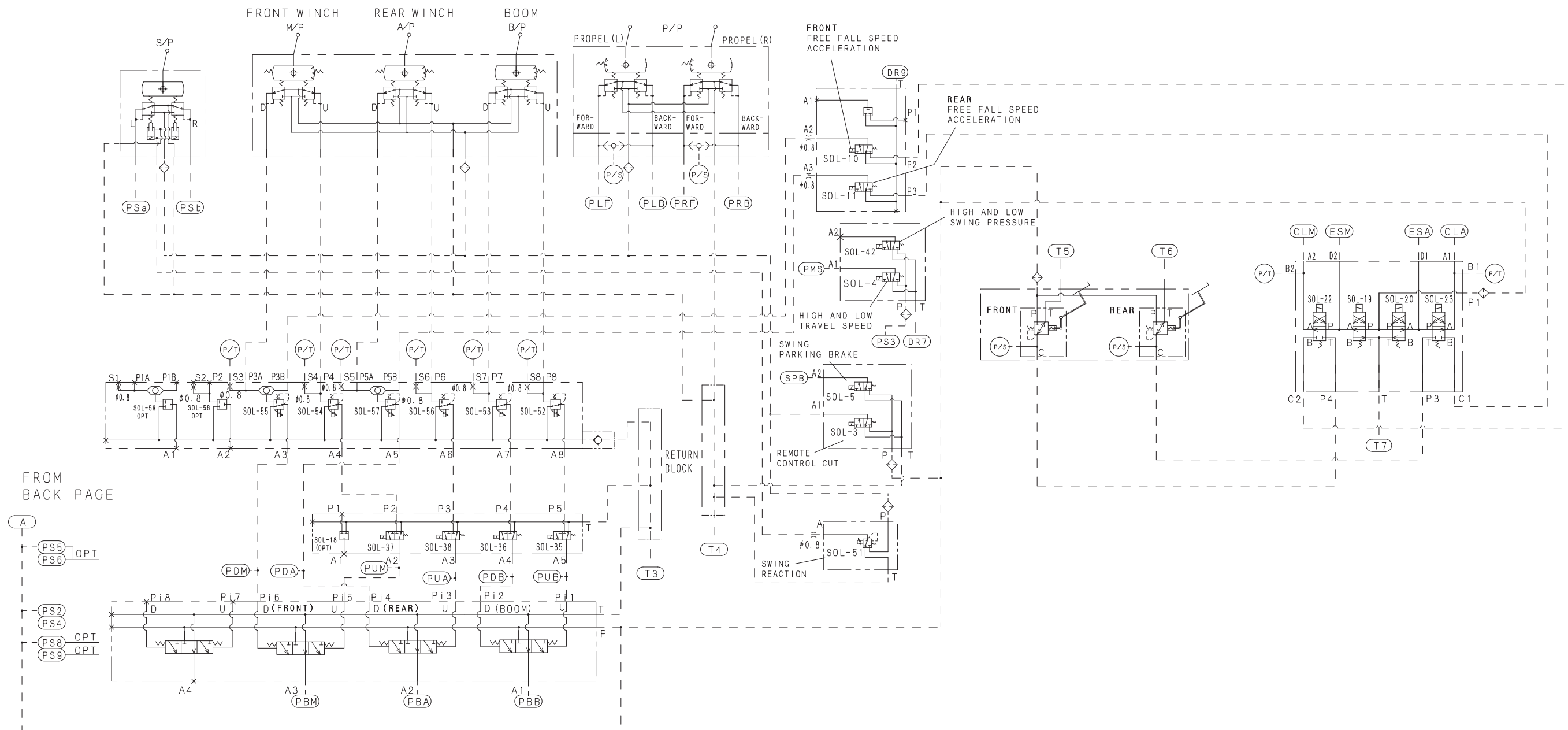

Reference Only

This page is blank for editing convenience.

6.6.2 LIFTING A LOAD

Function of the front drum and the rear drum are exactly same.

The front drum is explained here as an example.

Pressurized oil from the main pump (No.1, No.2) flows through the control valve to power the hoist system.

While the function lock lever is in the "Work" position (SOL-3 : On position), oil pressure from the control pump flows through the accumulator and into the foot brake valve block, the clutch valve block, brake valve block (4-section pilot operated valve) and through the valve block (2-section solenoid valves) and into the remote control valve.

The pressurized oil is also fed to the both sides oil chambers of the front drum clutch cylinder ("CLM", "ESM") via the clutch valve block (4-section solenoid valves).

Since the cylinder thrust force by the pressurized oil is not generated, the clutch is connected with the spring.

When the front drum control lever is operated in the "hoist load" direction, it directs control pressure oil through the remote control valve and into the "PUM" port of the main control valve where it moves the spool.

At the same time, the control pressurized oil flows into the "PBM" port of the brake cylinder built in the winch motor via the brake valve block (4-section pilot operated valves), and the motor brake is released.

As directed by the position of the spool, the main pump (No.1, No.2) oil flowing into the control valve is sent to the raising side of the hoist motor to drive the front drum and thereby raise the load.

U : UP
D : DOWN

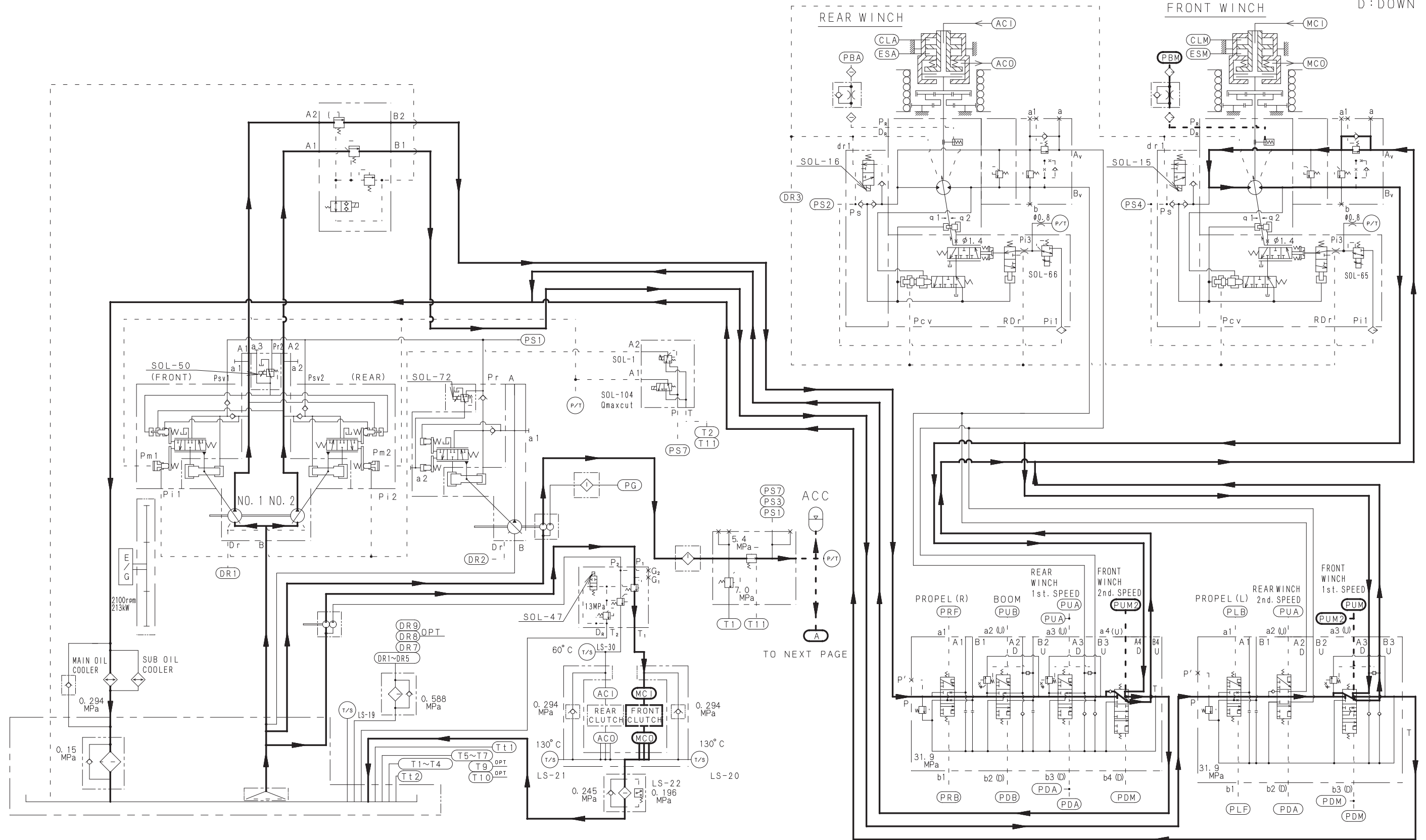

Lifting (1/2)

6. HOIST SYSTEM

U : UP
D : DOWN

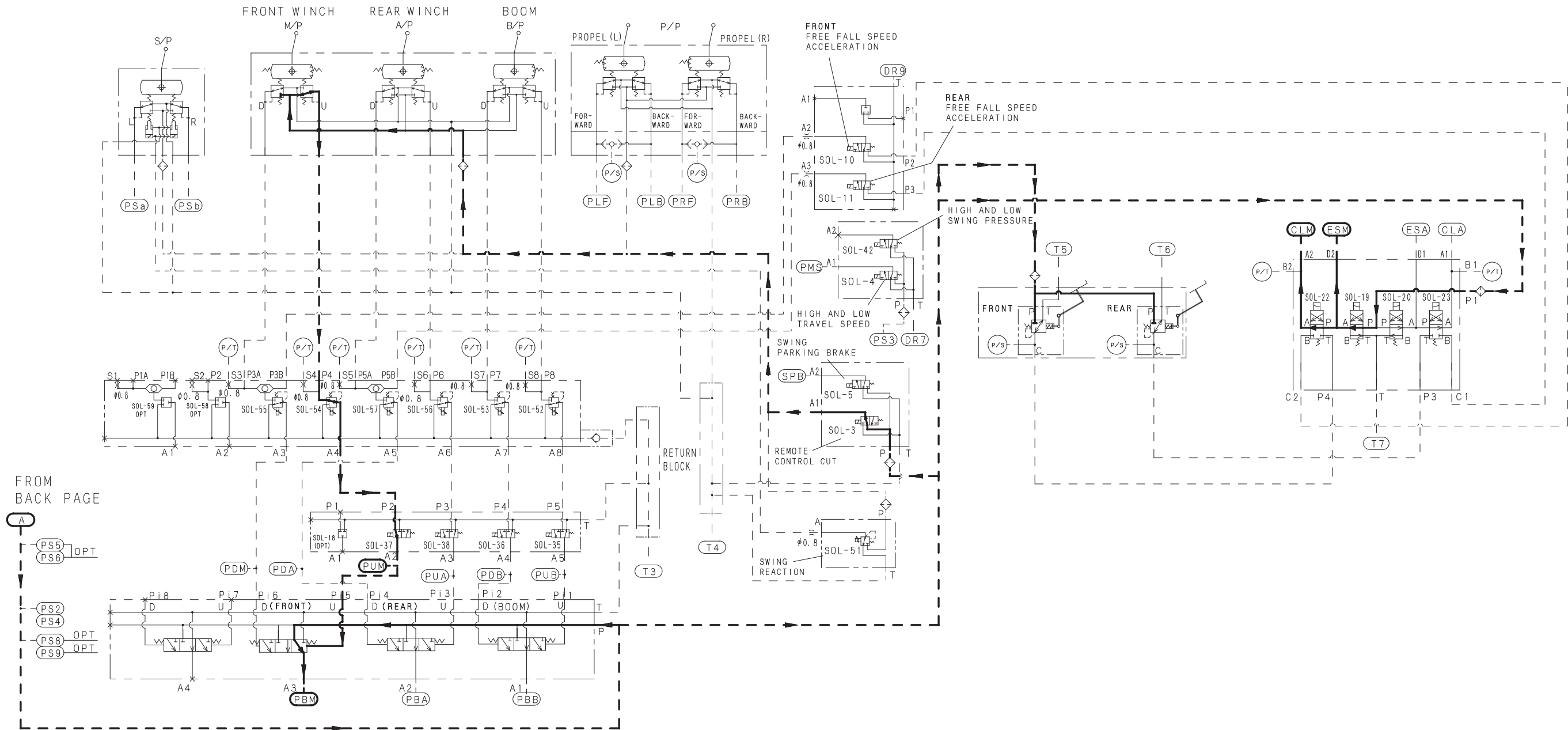

Reference Only

This page is blank for editing convenience.

6.6.3 HOLDING A RAISED LOAD

With the main control lever turned back to its neutral position, the control pressure coming from the remote control valve is cut and the spool in the main control valve returns to its neutral position.

When the spool returns to neutral, the pressurized oil to the main motor is cut off and the motor stops.

Now, although the weight of the suspended load continues to pull on the drum, further rotation of the drum is prevented by a motor counterbalance valve that blocks the return of oil to the reservoir.

At the same time, the control oil pressure in the motor brake cylinder is directed back to the reservoir and the motor brake (nega-brake) actuates.

The pressurized oil is fed to the both sides oil chambers of the clutch cylinder ("CLM", "ESM"), and the cylinder thrust force by the pressurized oil is not generated.

Therefore, the clutch remains engaged with the spring.

The load is now held in suspension by the combined effects of the motor counterbalance valve, the motor brake and the clutch.

U : UP
D : DOWN

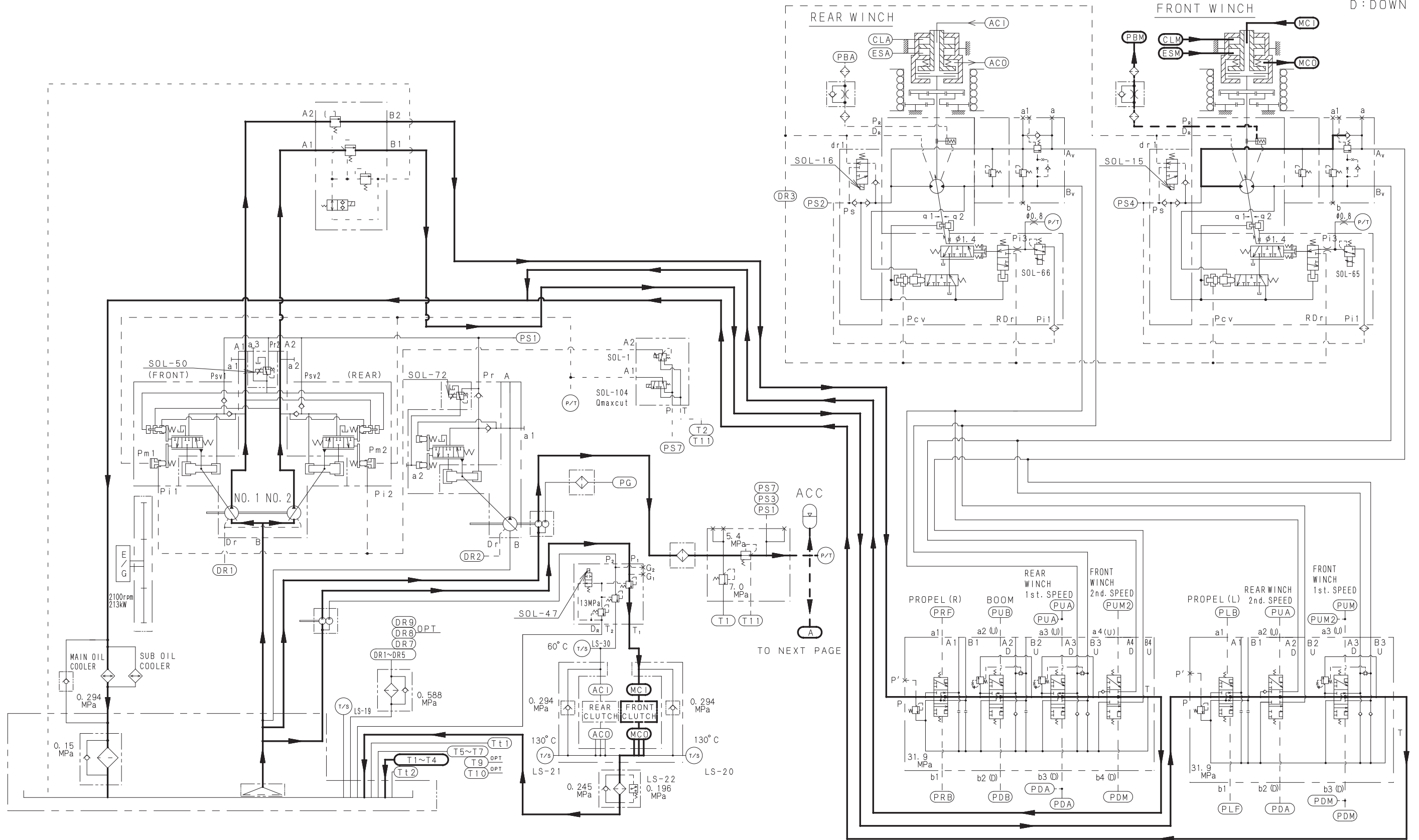

Holding (1/2)

Reference Only

This page is blank for editing convenience.

6.6.4 LOWERING A LOAD (POWER LOWERING)

Pressurized oil from the main pump (No.1, No.2) flows through the main control valve to power the front drum hoist system.

When the function lock lever is in the "Work" position (SOL-3 : ON position), oil pressure from the control pump flows past the accumulator and into the foot brake valve block, the clutch valve block, brake valve block (4-section pilot operated valve) and flows through the valve block (2-section solenoid valves) and into the remote control valve.

The pressurized oil is fed to the both sides oil chambers of the clutch cylinder ("CLM", "ESM") via the clutch valve block (4-section solenoid valves).

Since the cylinder thrust force by the pressurized oil is not generated, the clutch is engaged with the spring.

When the main control lever is operated to the "lower load" direction, this control oil pressure is directed by the remote control valve to flow into the port "PDM" and "PDM2" of the main control valve and it moves the spool.

At the same time, control pressure is also directed through the brake valve block (4-section pilot operated valve) to the "PBM" port of the motor brake cylinder.

It causes the motor brake to disengage.

Now the main pump (No.1, No.2) oil flowing into the control valve, as directed by the position of the spool, activates the hoist motor to drive the drum and thereby lower the load.

The counterbalance valve is opened by pilot pressure from the "running in" side to allow the main motor to rotate and lower the load.

U : UP
D : DOWN

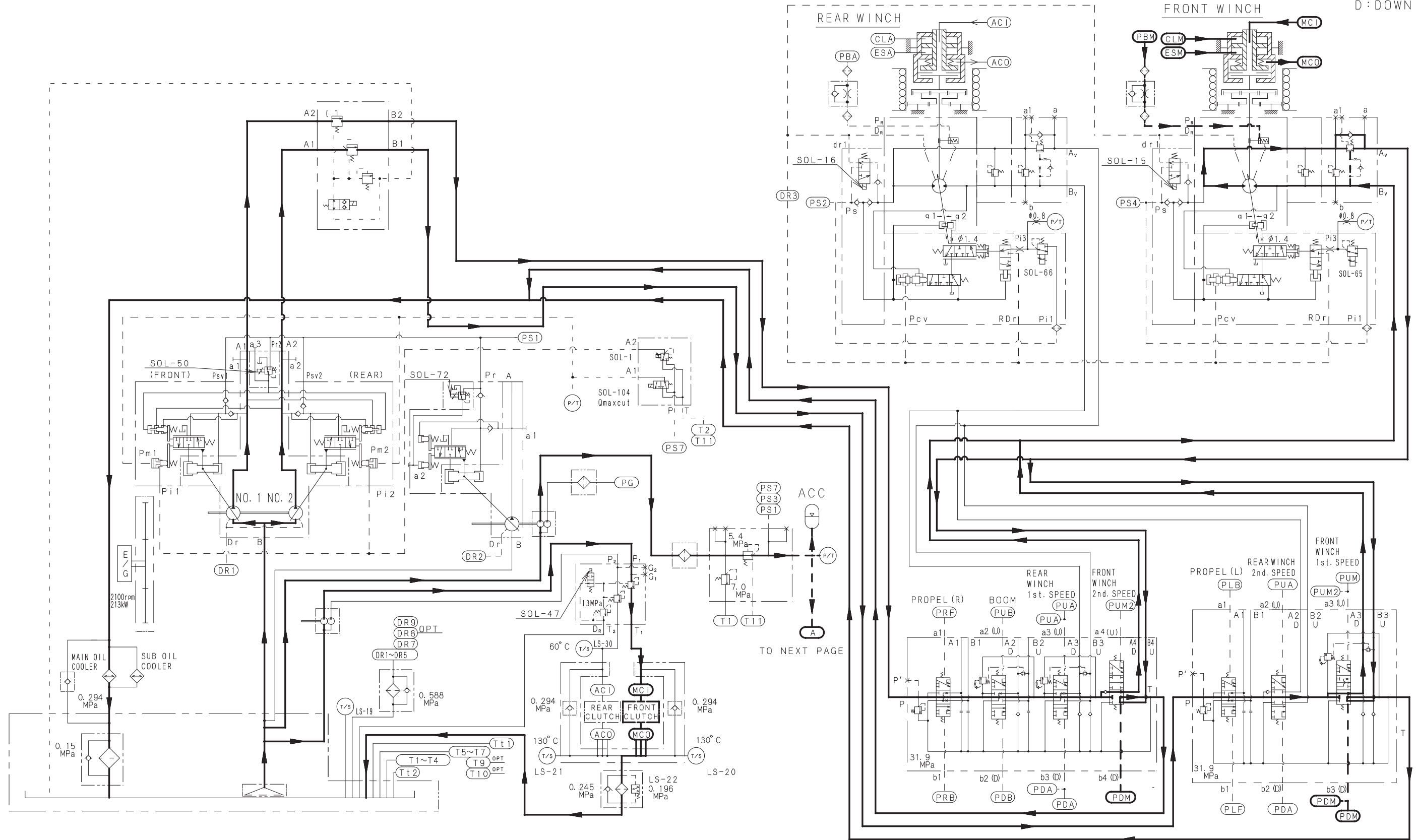

Lowering (Power lowering) (1/2)

U : UP
D : DOWN

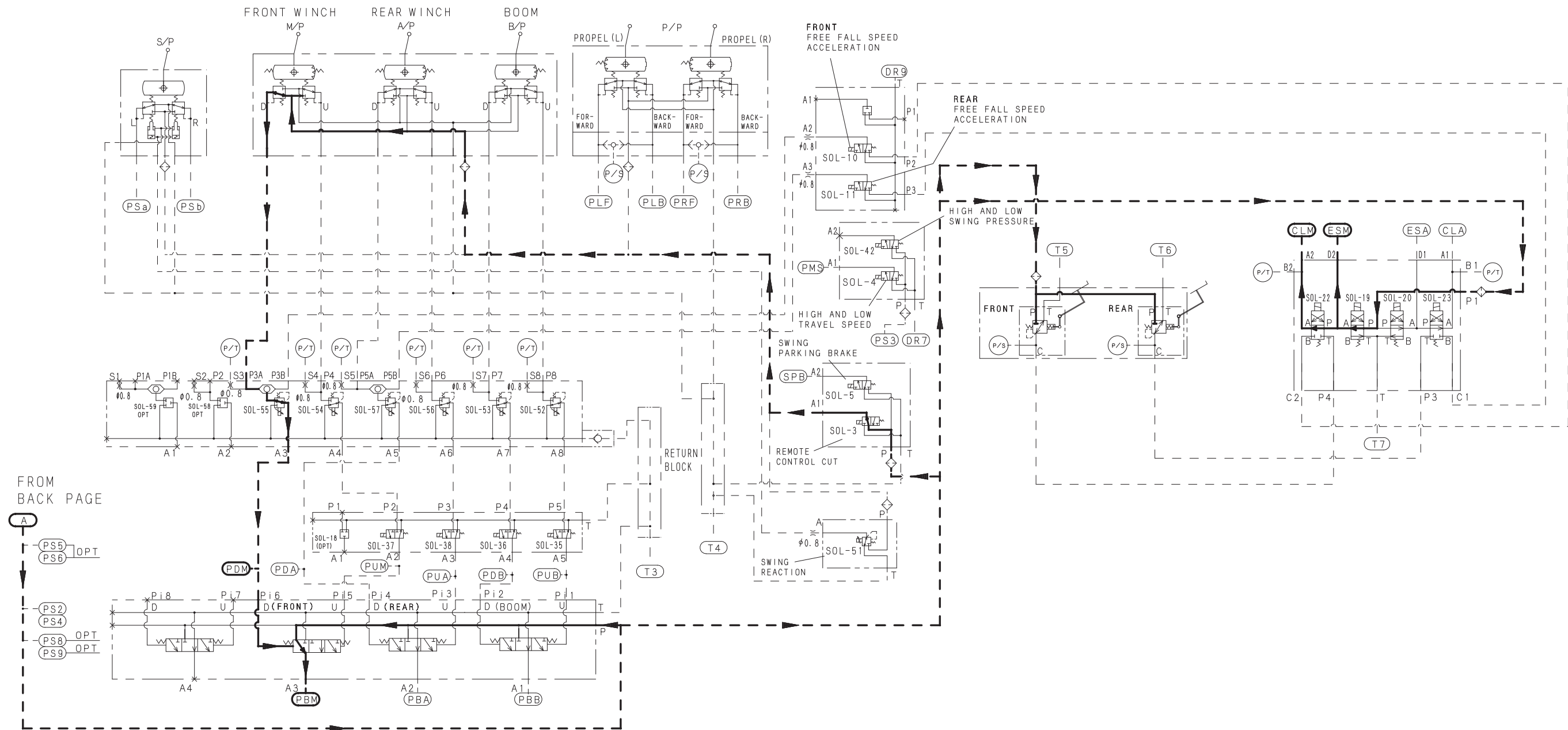

Lowering (Power lowering) (2/2)

Reference Only

This page is blank for editing convenience.

6.6.5 FREE FALL OPERATION

When the brake select switch is set to the "FREE FALL" side, the solenoid valve (SOL-22) in the clutch valve block (4-section solenoid valves) is switched over.

When the solenoid valve is switched over and the front drum foot brake is released, the pressurized oil in the "CLM" side oil chamber of the front drum clutch cylinder returns to the tank, and the cylinder thrust force is generated against the spring to release the clutch.

As a result, the load falls freely (free fall), and the brake can be applied with the foot brake.

When the brake pedal is operated, the control pressurized oil flows into the "CLM" side oil chamber of the clutch cylinder through the front drum foot brake valve, and the cylinder thrust force is decreased to actuate the brake (braking with the clutch).

Reference

U : UP
D : DOWN

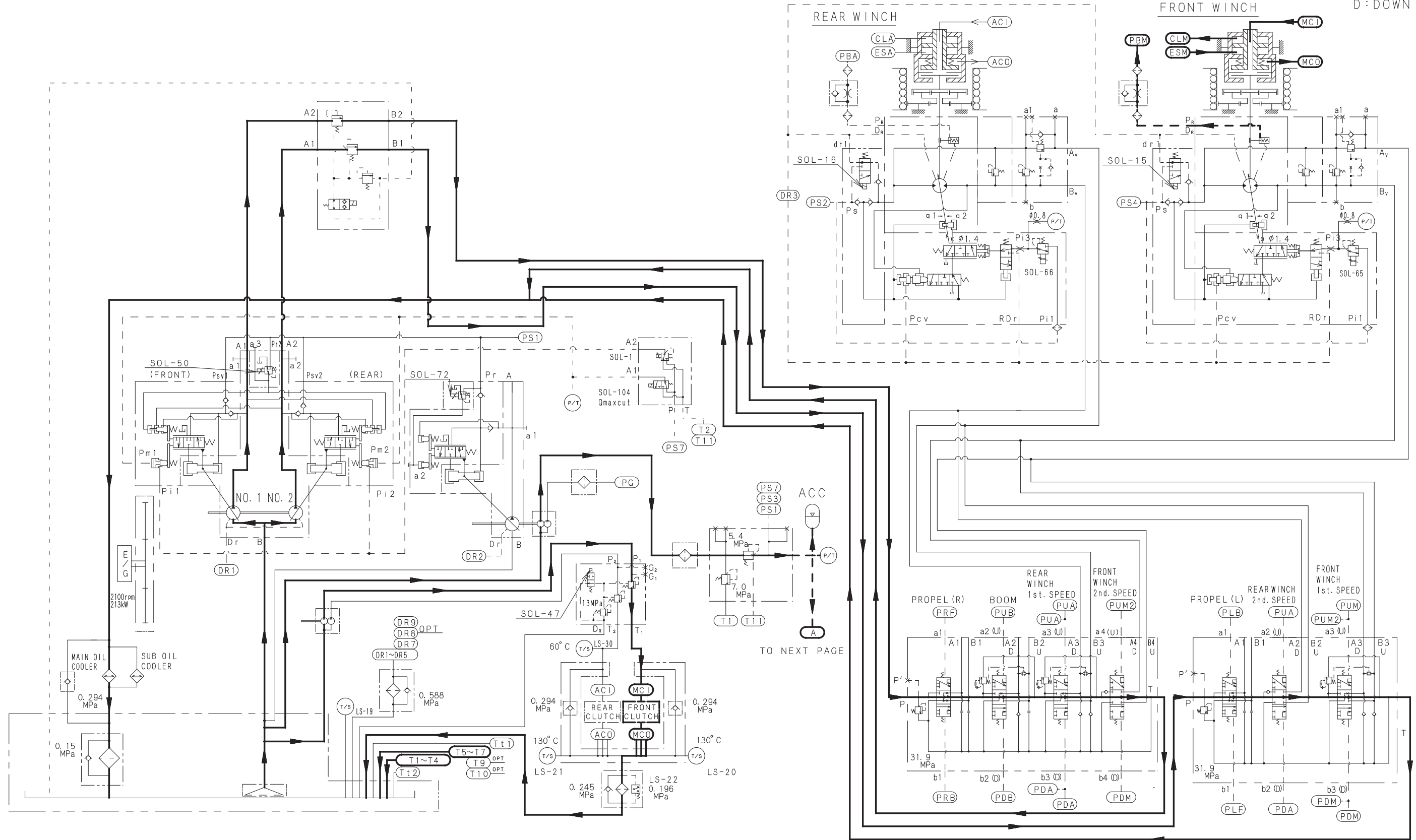

TO NEXT PAGE

Free Fall (1/2)

6. HOIST SYSTEM

U : UP
D : DOWN

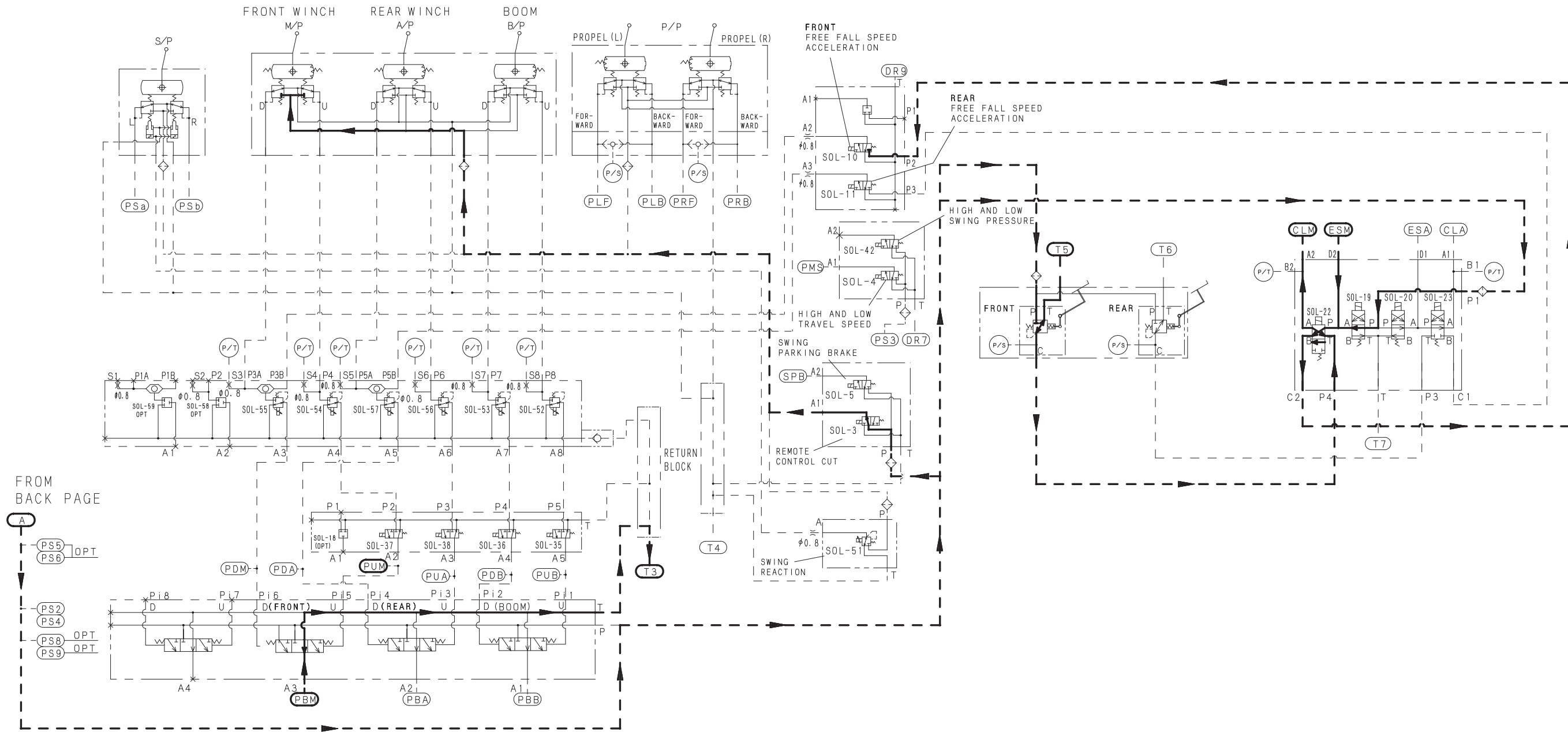

Free Fall (2/2)

6. HOIST SYSTEM

U : UP
D : DOWN

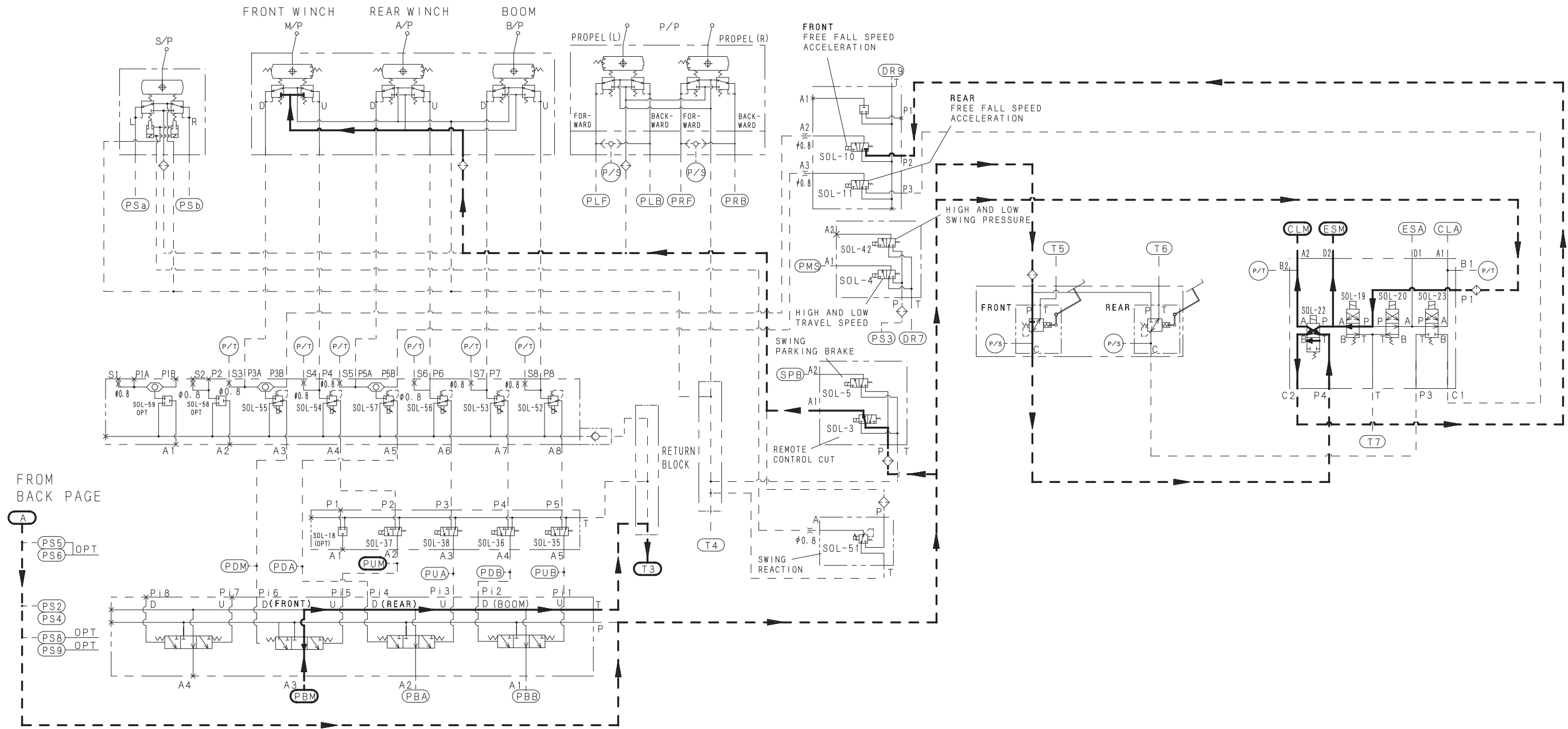

Free Fall Control (2/2)

Reference Only

This page is blank for editing convenience.

FREE FALL ACCELERATION

Free fall with the "FREE FALL SPEED SELECT SWITCH" on the left upper switch panel set to the "HIGH" position

When the front drum foot brake pedal is released, the solenoid valve (SOL-10) is switched over, and pressurized oil from the clutch valve block (4-section SOL) flows into the "PDM" and "PDM2" port of the main control valve through the shuttle valve and solenoid proportional valve (SOL-55) to move the spool.

At the same time, the oil also goes into the brake cylinder "PBM" port of the winch motor through the brake valve block (4-section pilot operated valves) to release the motor brake.

Then, the motor rotates to the lowering direction. Though the clutch is released while the "FREE FALL" mode is selected and the foot brake is released, the rotation of the winch motor is transmitted to the drum, and the free fall speed is increased by the power lowering, because the rotation resistance of the clutch is larger than that of the drum.

In this status, the drum can rotate without any load.

When the brake pedal is depressed, pressurized oil is fed to the "CLM" side of the clutch cylinder through the front drum foot brake valve.

Then, the cylinder thrust force is decreased to slow down the free fall speed, and the control pressure from the solenoid valve (SOL-10) in the 3-section valve block is also decreased by the proportional valve (SOL-55) and the solenoid valve (SOL-10) to return the main control valve spool to the neutral position.

When the spool is returned to the neutral position, pressurized oil to the motor is shut off, and the main motor stops rotating.

U : UP
D : DOWN

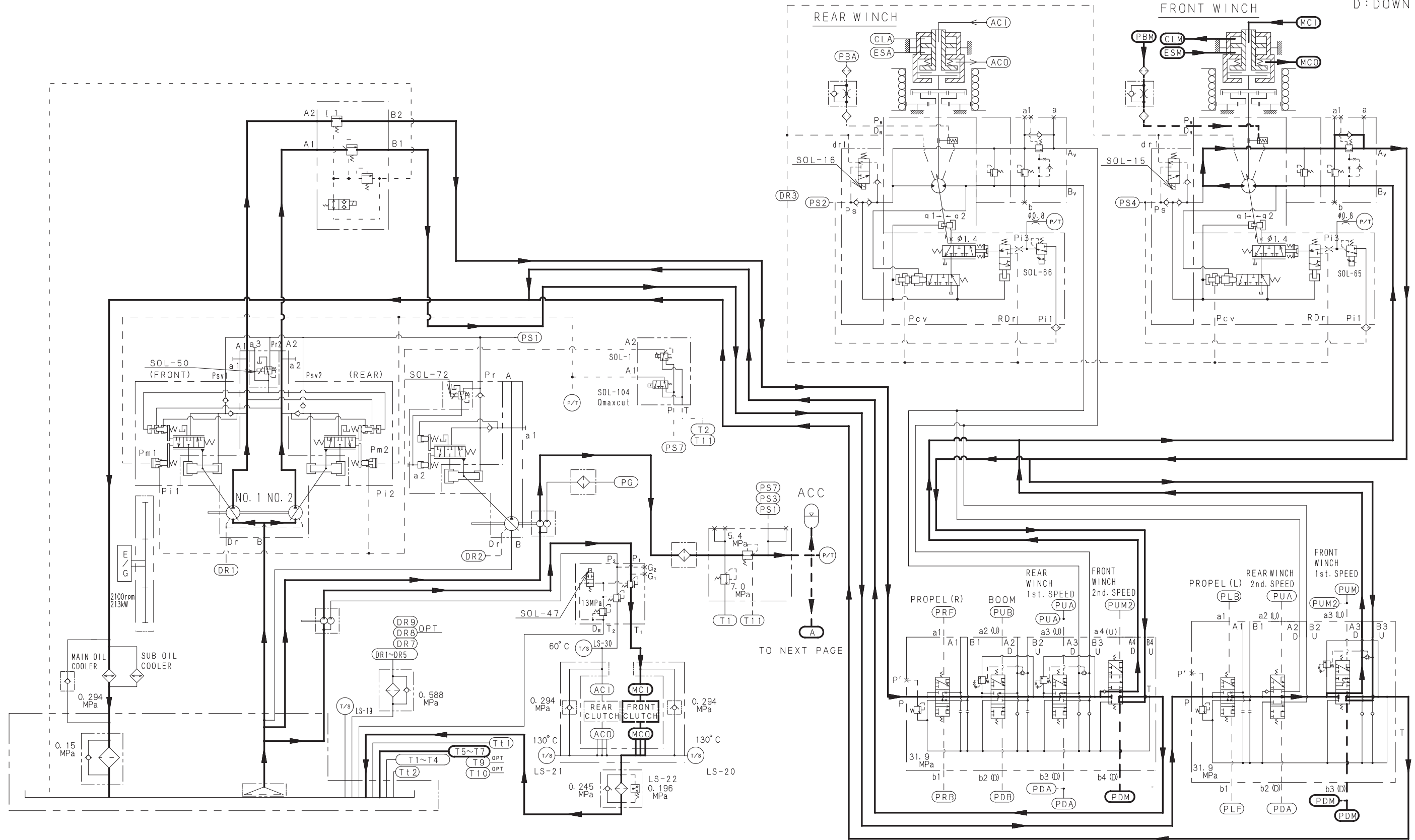

Free Fall Speed Acceleration (1/2)

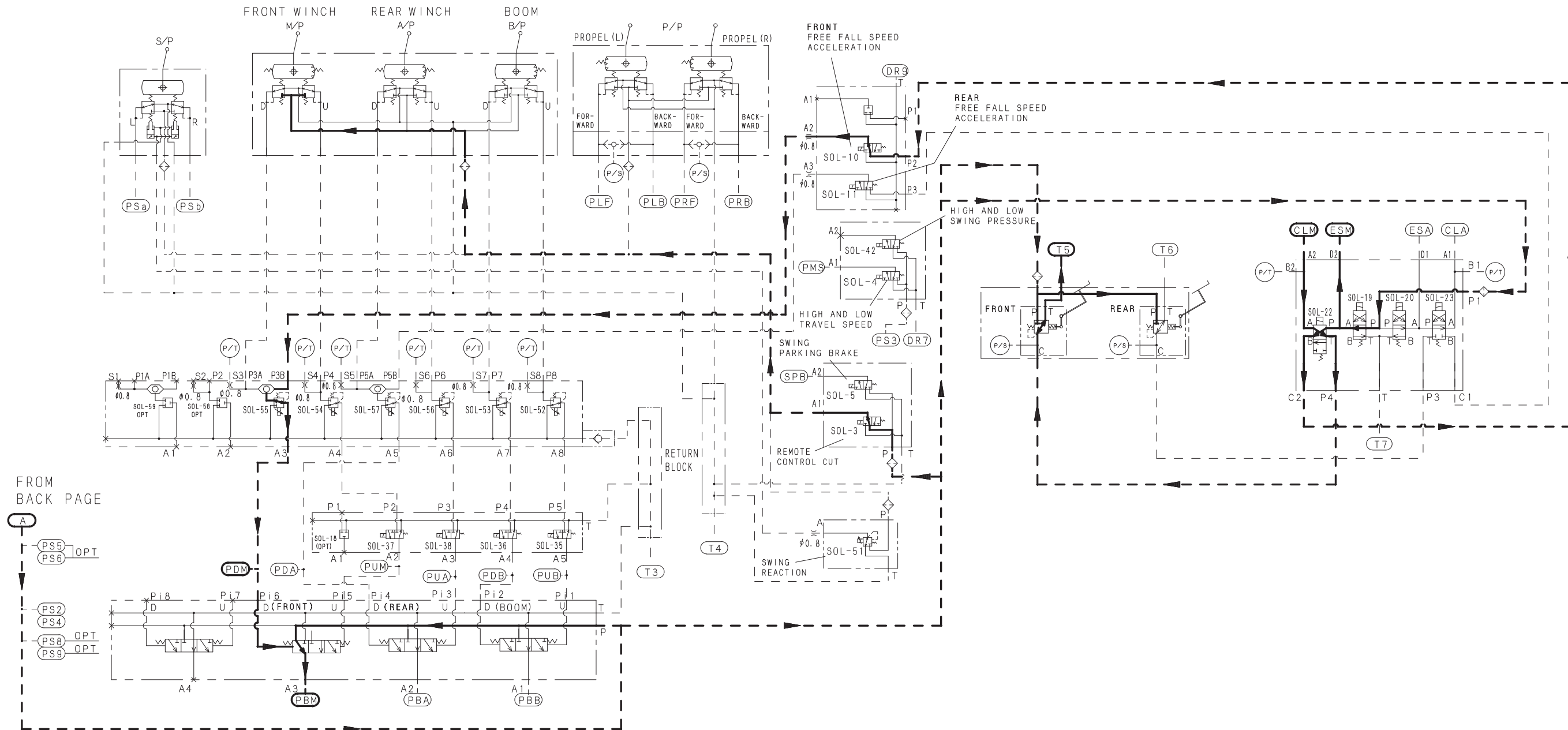

Free Fall Speed Acceleration (2/2)

7. BOOM HOIST SYSTEM

Reference Only

Reference Only

7.1 APPARATUS AND LOCATION OF COMPONENTS

The boom hoist system consists of the main pump, the main control valve, the boom drum motor, the reduction unit, the boom drum and the drum lock mechanism.

The pressurized oil for the boom hoist system is supplied by the main pump (No.1) installed on the engine's power divider. From this pump, the oil flows through the 4 section side control valve to drive the motor of the boom drum.

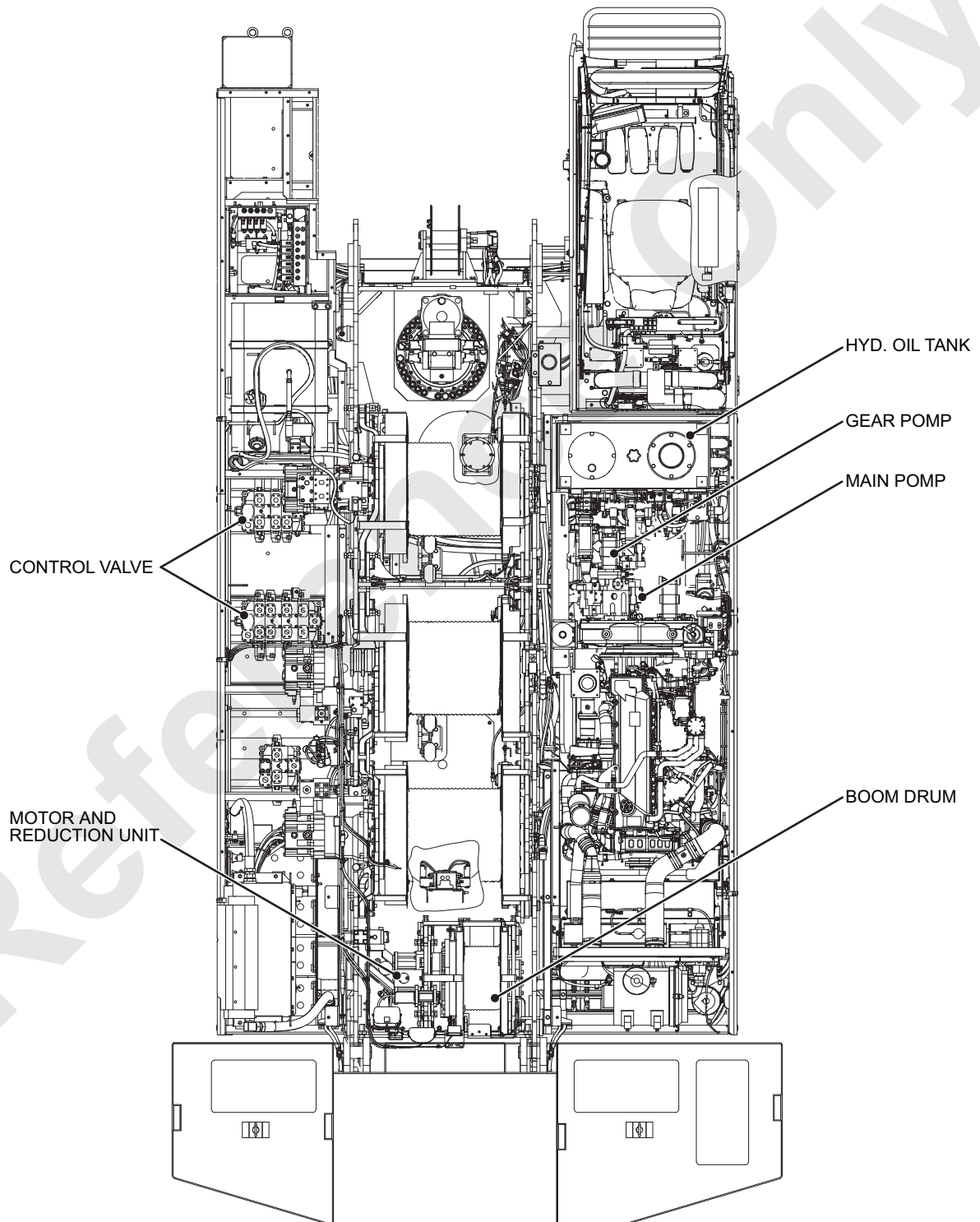

7. BOOM HOIST SYSTEM

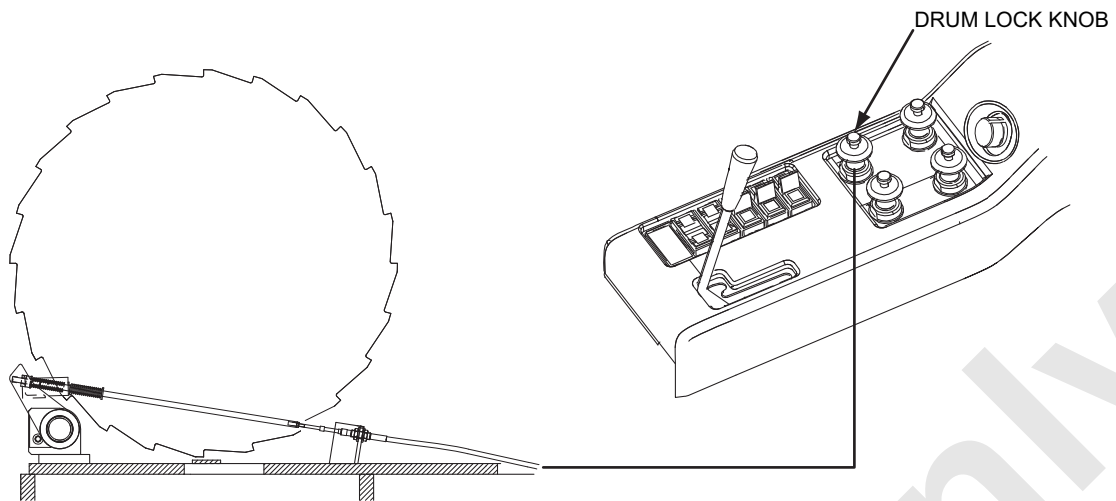

As for raising, neutral and lowering circuit and functions, refer to P.7-11 to 7-17.

7.2 BOOM HOIST WINCH INSTALLATION

When boom hoist winch is to be installed or removed, perform work observing the following tightening torque and note.

Note

When replacing the gear oil, use the specified type of oil and fill in to the specified level.

Specified type of oil : Extreme pressure gear oil SAE#90 (API-GL4)
or SAE#80W-90

Specified volume : Approx. 3ltr.

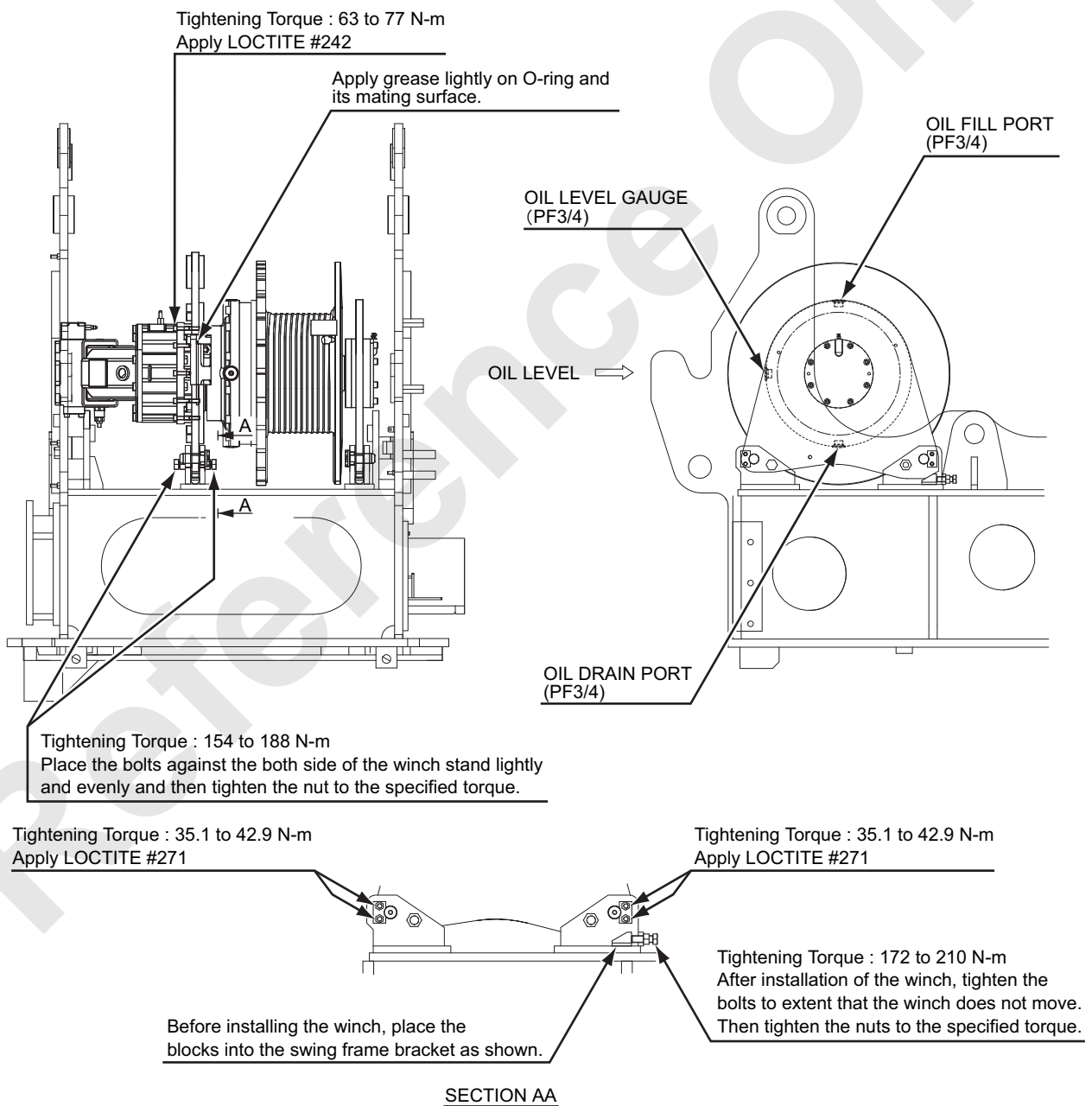

7. BOOM HOIST SYSTEM

7.3 BOOM DRUM LOCK

7.3.1 ASSEMBLY DRAWING

When the assembly is complete, fill grease until it is squeezed out from the clearances of the pawl.

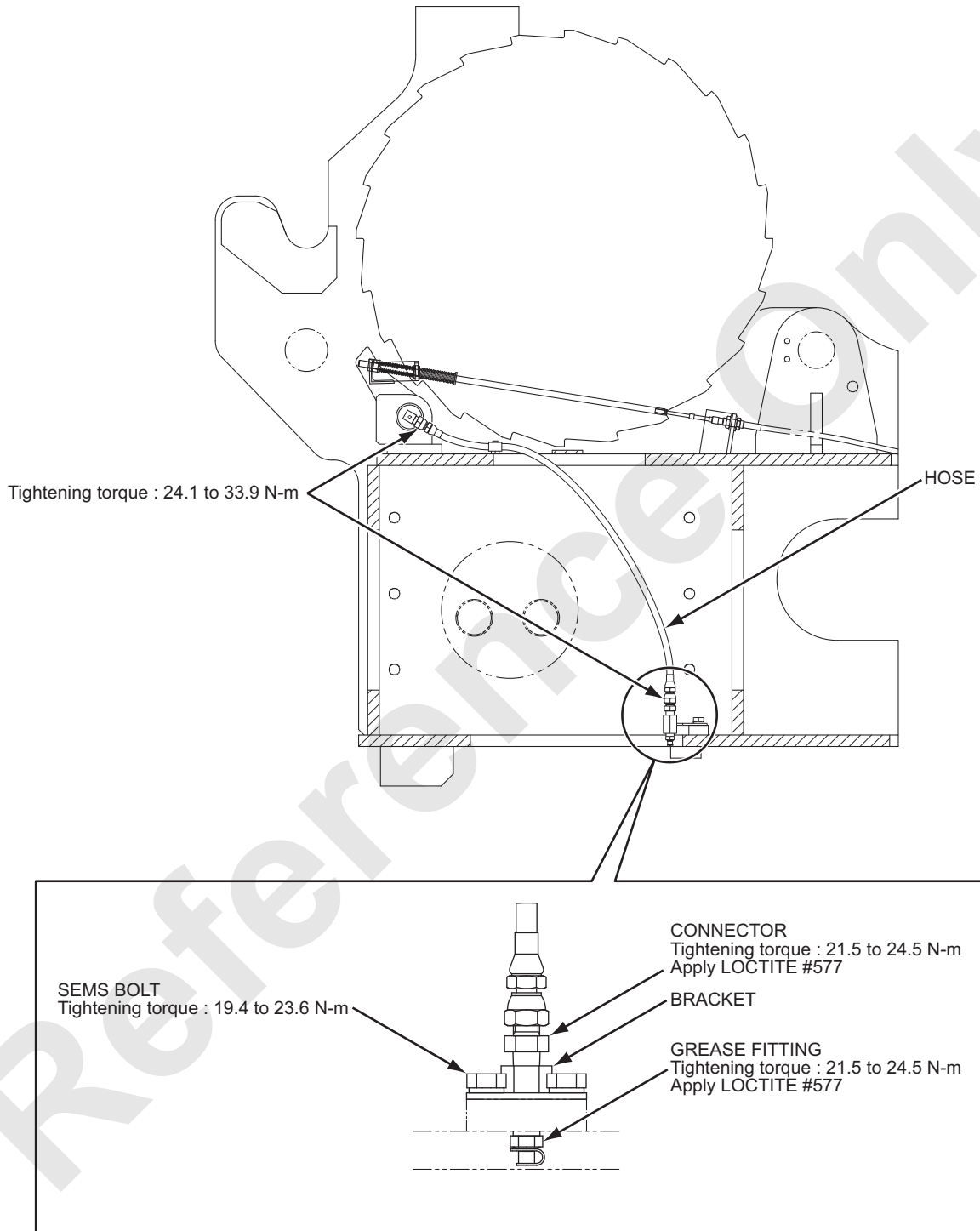

7.3.2 ADJUSTING THE BOOM DRUM LOCK

⚠ WARNING

Ensure to adjust the boom hoist drum lock while the boom has been lowered to the ground.

Failure to observe this precaution may result in serious injury or loss of life.

1. Turn the boom hoist lever to neutral and pull the drum lock knob in the LOCK position and check to see that the pawl is engaged in the bottom of the drum ratchet.
If the pawl is not engaged in the bottom of the ratchet, adjust the spring dimension to allow the pawl to be engaged in the bottom.
 2. Push the drum lock knob fully and check to see that the pawl is clear of the ratchet by at least 26 mm. Operate the knob to push and pull for a few times and confirm that the pawl moves smoothly.
 3. Push and pull the knob for a several times to check for the smooth movement of the pawl.
-

⚠ WARNING

Keep hands and clothing clear of the rotating drum.

Failure to observe this precaution may result in serious injury or loss of life.

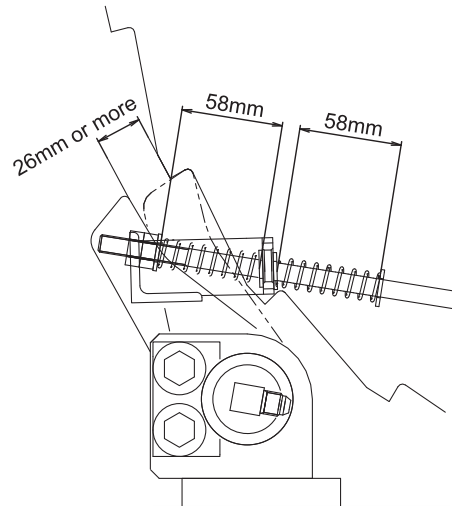

Refer

7.4 REDUCTION UNIT

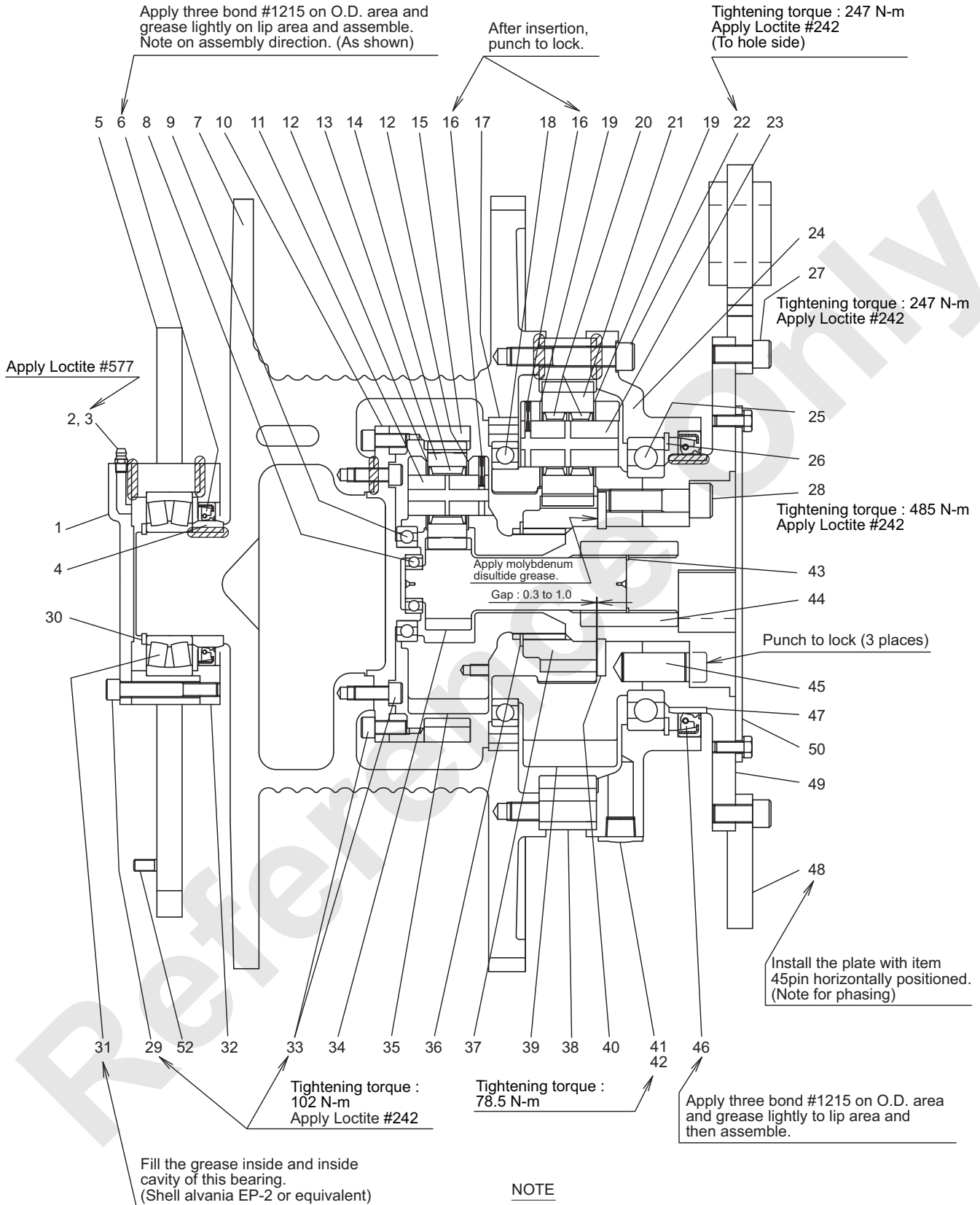

- | | | |
|--------------------|--------------------|---------------|
| 1. Cover | 19. Thrust washer | 37. Sun gear |
| 2. Grease fitting | 20. Needle bearing | 38. Ring gear |
| 3. Cap | 21. Pinion | 39. Carrier |
| 4. Sleeve | 22. Hex. set screw | 40. Spacer |
| 5. Plate | 23. Pin | 41. Plug |
| 6. Oil seal | 24. Sleeve bearing | 42. O-ring |
| 7. Drum | 25. Bearing | 43. Snap ring |
| 8. Bearing | 26. Snap ring | 44. Collar |
| 9. Bearing | 27. Hex. set screw | 45. Pin |
| 10. Cover | 28. Hex. set screw | 46. Oil seal |
| 11. Pin | 29. Hex. set screw | 47. Sleeve |
| 12. Thrust washer | 30. Snap ring | 48. Plate |
| 13. Pinion | 31. Bearing | 49. Retainer |
| 14. Needle bearing | 32. Plate | 50. Plate |
| 15. Ring gear | 33. Hex. set screw | 51. Plate |
| 16. Spring pin | 34. Sun gear | 52. Stud bolt |
| 17. Spacer | 35. Carrier | |
| 18. Bearing | 36. Snap ring | |

TIGHTENING TORQUE TABLE

Item	Name	Size	Tightening Torque (N-m)
22	Capscrew	M16 X 90	222 to 272
27	Capscrew	M16 X 35	222 to 272
28	Capscrew	M20 X 70	436 to 534
29	Capscrew	M12 X 85	92 to 112
33	Capscrew	M12 X 25	92 to 112
41	Plug		70.6 to 86.4

This page is blank for editing convenience.

7.5 CONSTRUCTION AND FUNCTION

7.5.1 HYDRAULIC SCHEMATIC

U : UP
D : DOWN

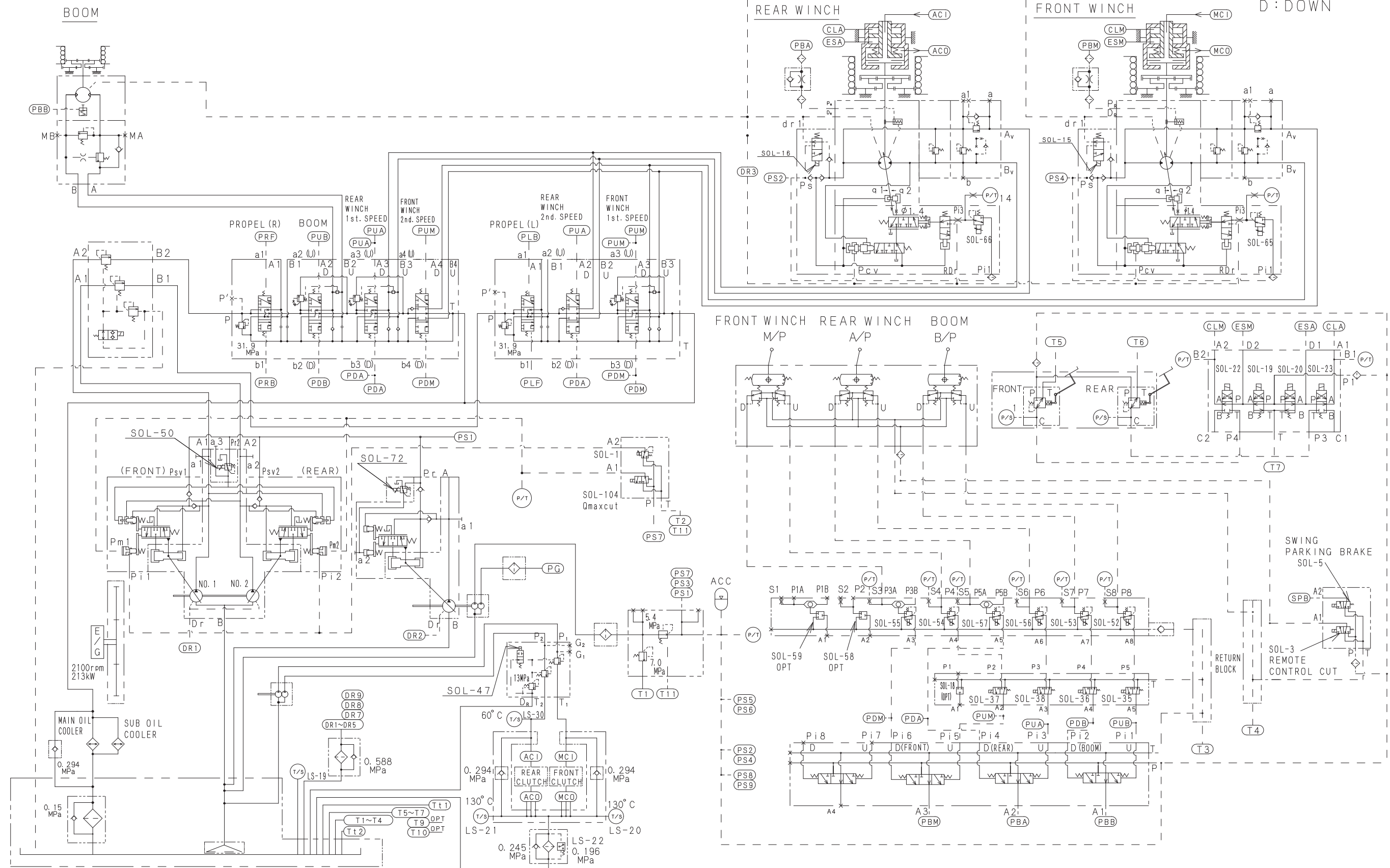

BOOM HOIST HYD. CIRCUIT

7.5.2 RAISING THE BOOM

Pressurized hydraulic oil from the main pump (No.1) flows into 4 section side of the main control valve.

The control pressurized oil from the control valve flows into the valve block and remote control valve through the accumulator. (Function lock lever is in WORK POSITION : 2 section valve block SOL-3 is CHANGING POSITION)

At this time, turning the control lever to raising side make the control pressured oil pass through the remote control valve, 8 section valve, 5 section valve and 4 section valve and enter into the PUB port of the control valve to move the boom section spool.

At the same time, control pressured oil also enters into the negative brake cylinder through the valve block (4 section hyd. selecting valve) and the motor brake is released.

Main pressured oil flow into the control valve enters into the raising side of the boom drum motor by the boom section spool and the boom is raised.

U : UP
D : DOWN

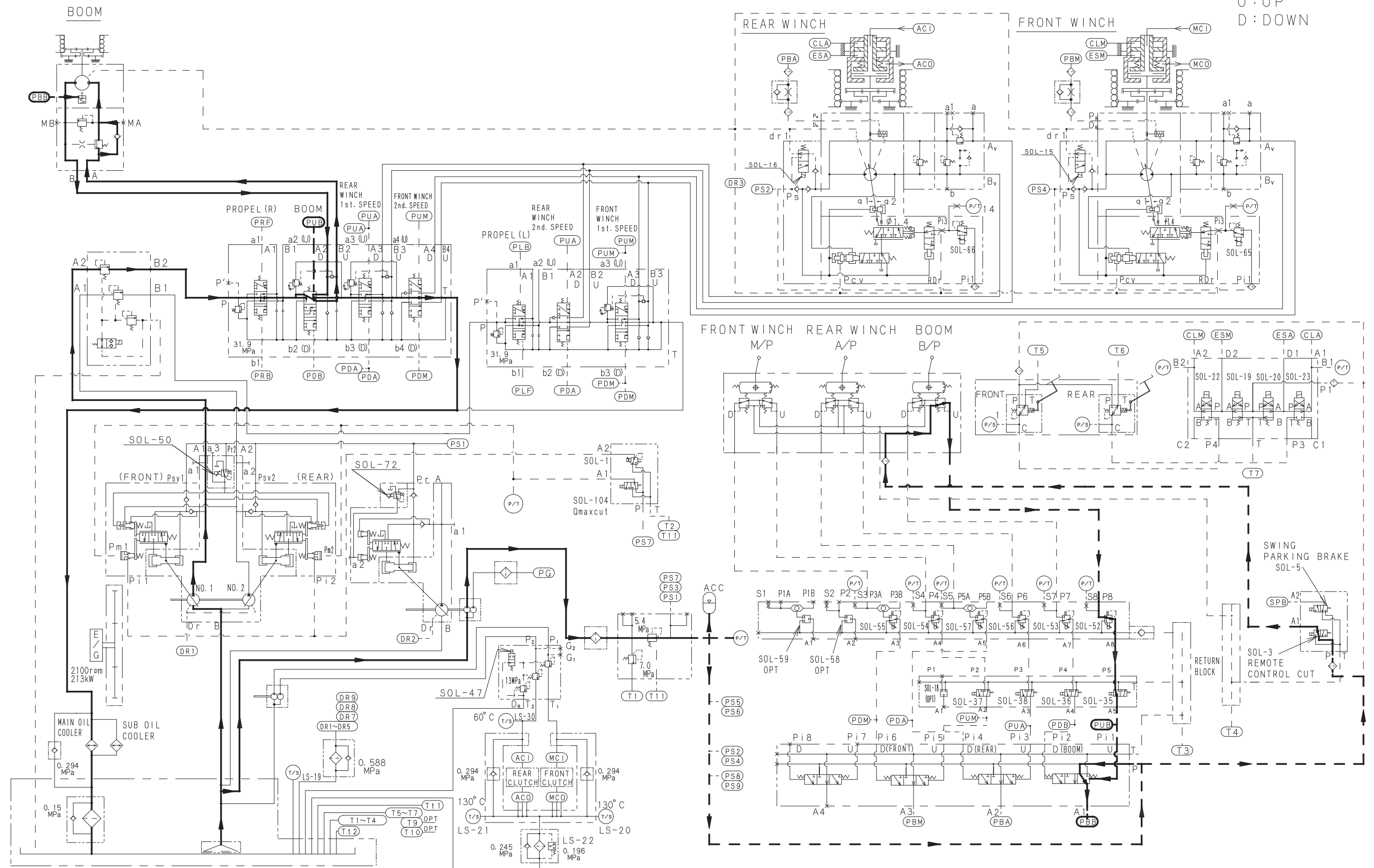

BOOM RAISING

7.5.3 NEUTRAL (HOLDING BOOM)

When the control lever is returned to neutral, control pressure of the remote control valve is shut off and main control valve spool returns to neutral and pressured oil from the main pump (No.1) passes through the control valve and returns to the tank without load. The stopped motor tends to rotate toward lowering side by boom weight. But the return oil is shut off by the counterbalance valve and motor does not rotate.

At the same time, pressured oil flown into the boom drum motor brake cylinder returns to the tank through the valve block (4 section hyd. selecting valve) and the motor brake becomes actuated.

(Negative brake)

Therefore the boom is held by the counterbalance motor brake.

Reference

U : UP
D : DOWN

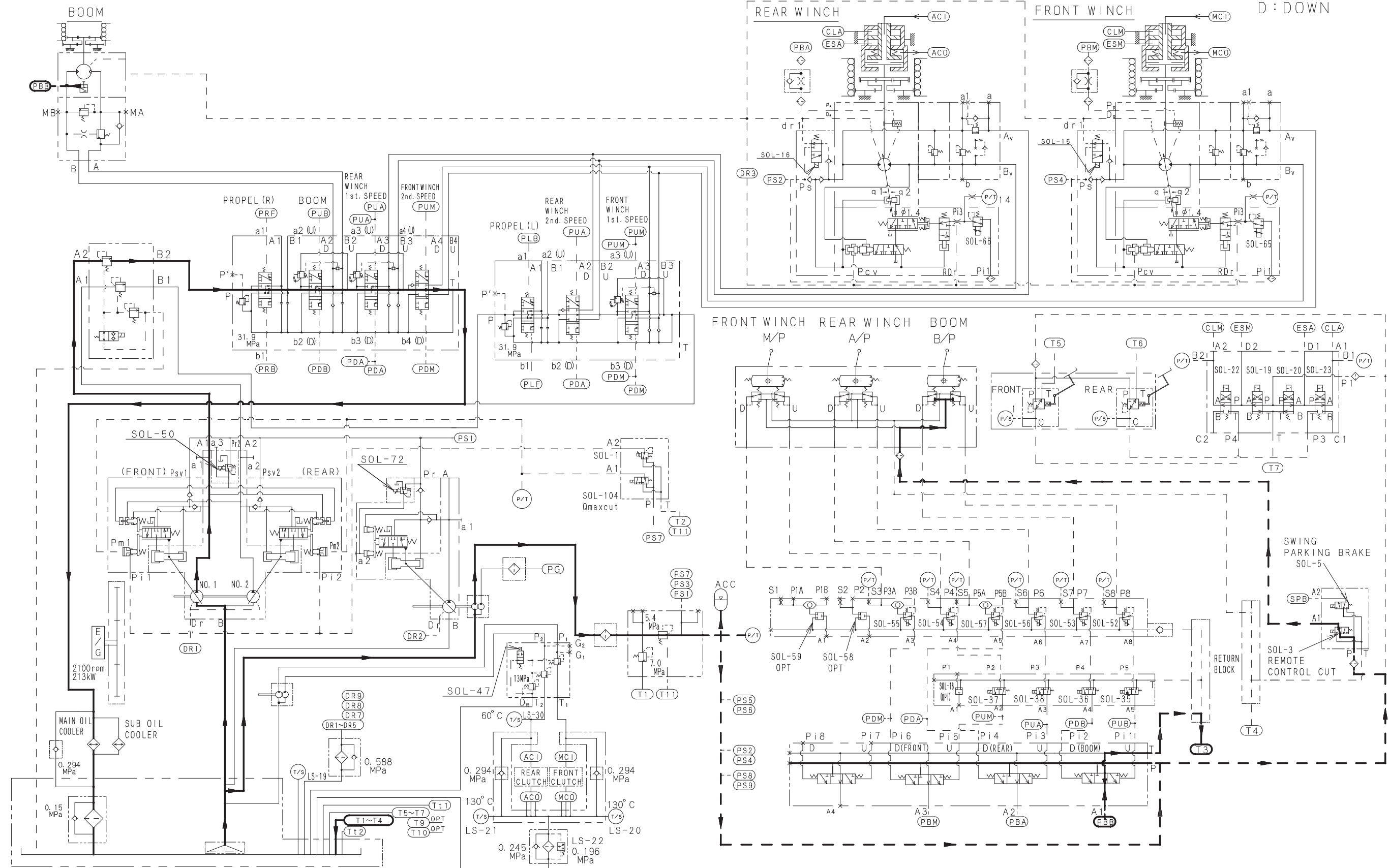

BOOM HOLDING

7.5.4 LOWERING BOOM

The pressured oil from the No.1 main pump flows into the 4 section side main control valve. The control pressured oil from the control pump flows into the valve block and remote control valve through the accumulator. (Function lock lever is in WORK POSITION : 2 section valve block SOL-3 is CHANGING POSITION)

At this time, turning the control lever to lowering side make the control pressured oil pass through the remote control valve, 8 section valve, 5 section valve and 4 section valve and enter into the PDB port of the control valve to move the boom section spool.

At the same time, control pressured oil also enters into the built in motor brake in the boom drum motor and the motor brake is released.

Main pressured oil flow into the control valve enters into the lowering side of the boom drum motor by the control valve and open the return counterbalance valve and the boom is lowered.

Reference Only

This page is blank for editing convenience.

8. SWING SYSTEM

Reference Only

Reference Only

8.1 APPARATUS AND LOCATION OF COMPONENTS

The swing system consists of the swing pump, the swing motor (built in swing brake), the swing control valve, the reduction unit, the swing bearing ring, the swivel joint, the swing gear and the swing lock.

To swing the machine's upper machinery, pressurized oil from the swing pump (No.3) mounted on the power divider is sent to the swing motor by way of the control valve which is directly mounted on the swing motor.

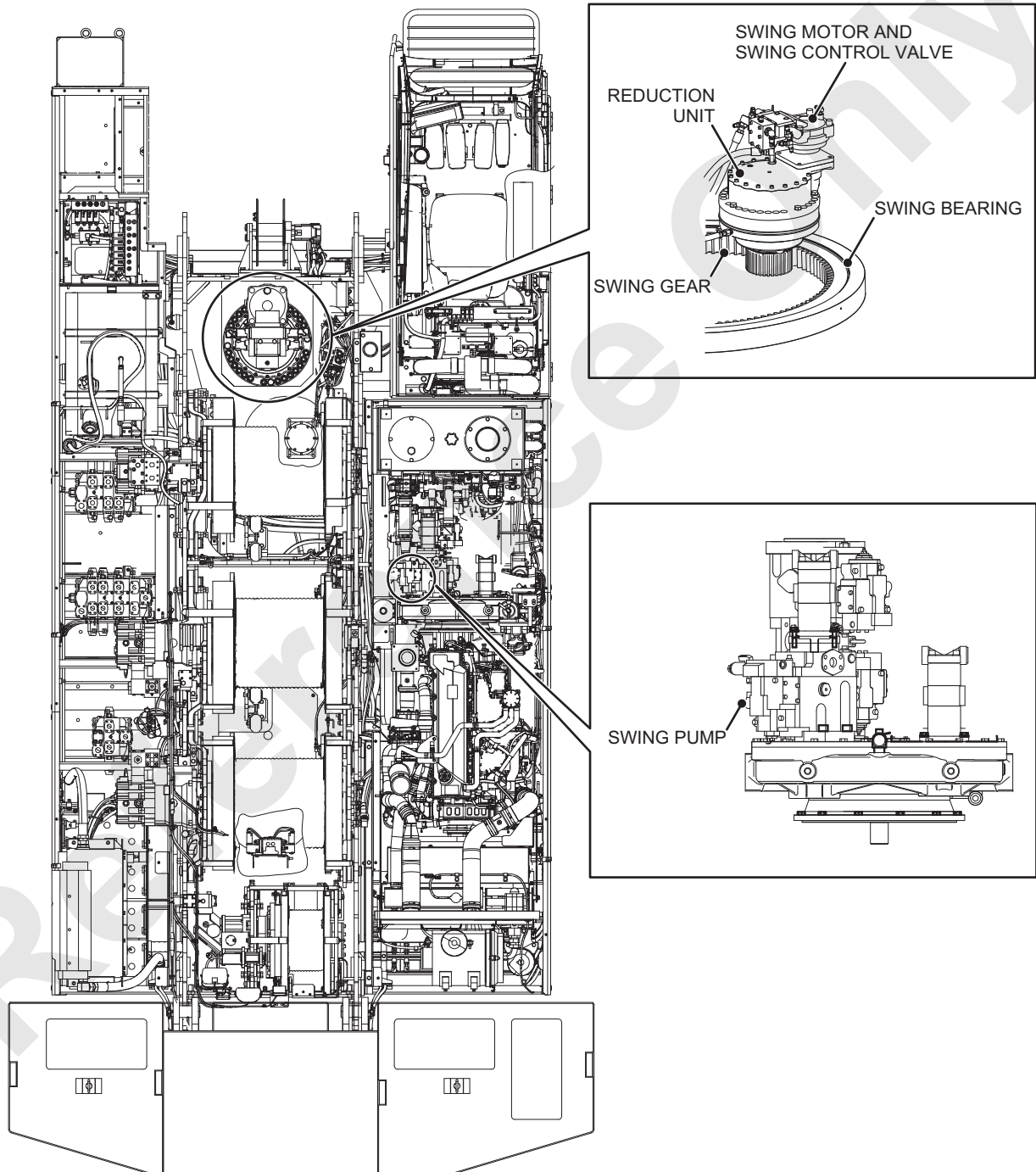

8. SWING SYSTEM

8.2 CONSTRUCTION AND FUNCTION

8.2.1 HYDRAULIC SCHEMATIC

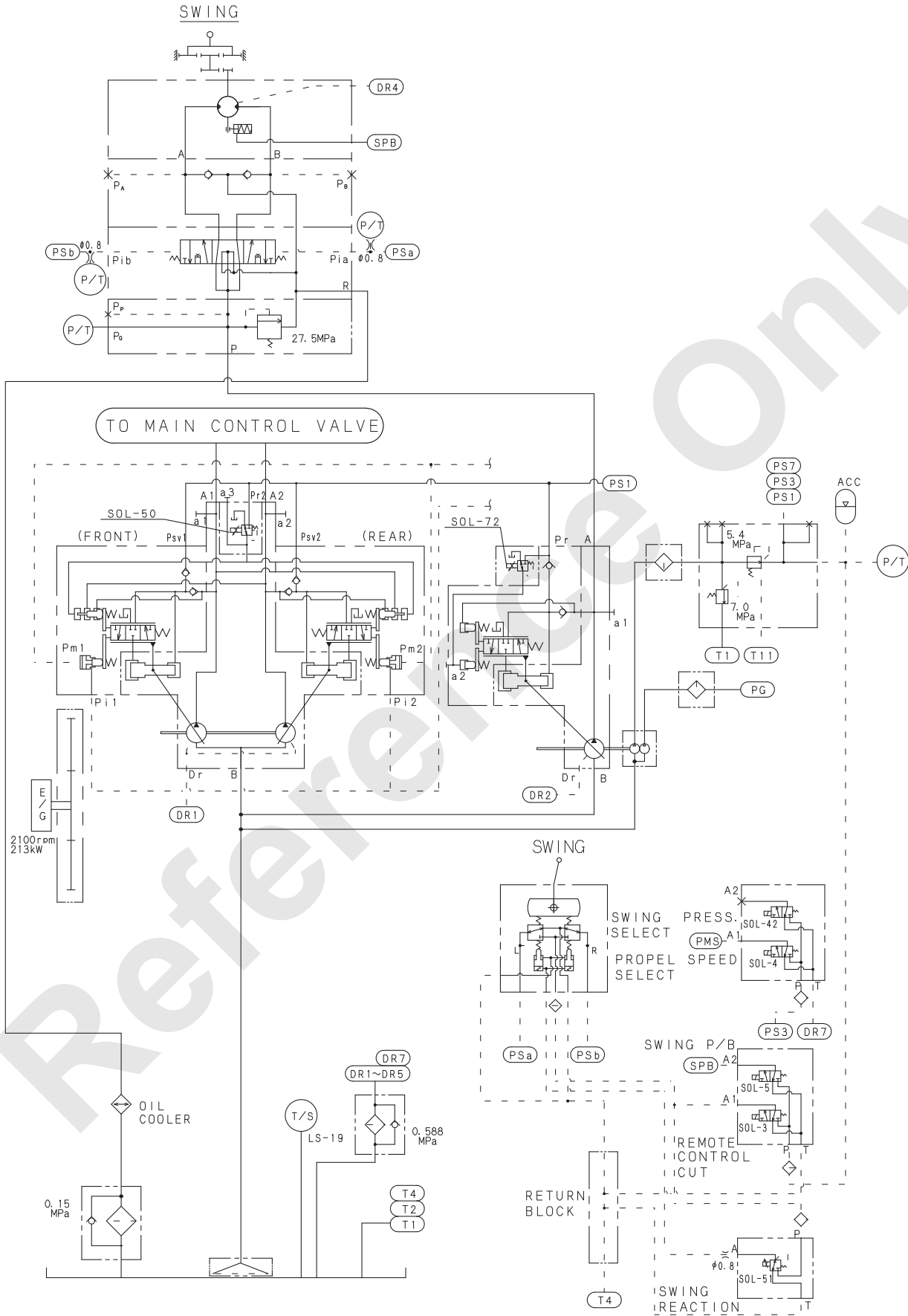

This page is blank for editing convenience.

Reference Only

8. SWING SYSTEM

8.2.2 SWING

The working principle of right swing, and left swing are identical.

The right swing is explained here.

[The swing brake is released ("SPB" SOL-5 is actuated).]

The pressurized oil from the swing pump is led to the swing control valve.

On the other hand, the control pressurized oil from the control pump flows through the accumulator, and into the valve block, swing remote control valve.

[The function lock lever is in the "Work" position (SOL-3 is actuated).]

When the swing control lever is turned to right swing (rear side), pressured control oil passes through the remote control valve and flows into the (PSb) port of the control valve and move the spool (A).

The main pressured oil controlled by the control valve flows into the swing motor to run the swing motor.

SWING (Neutral Free Mode)

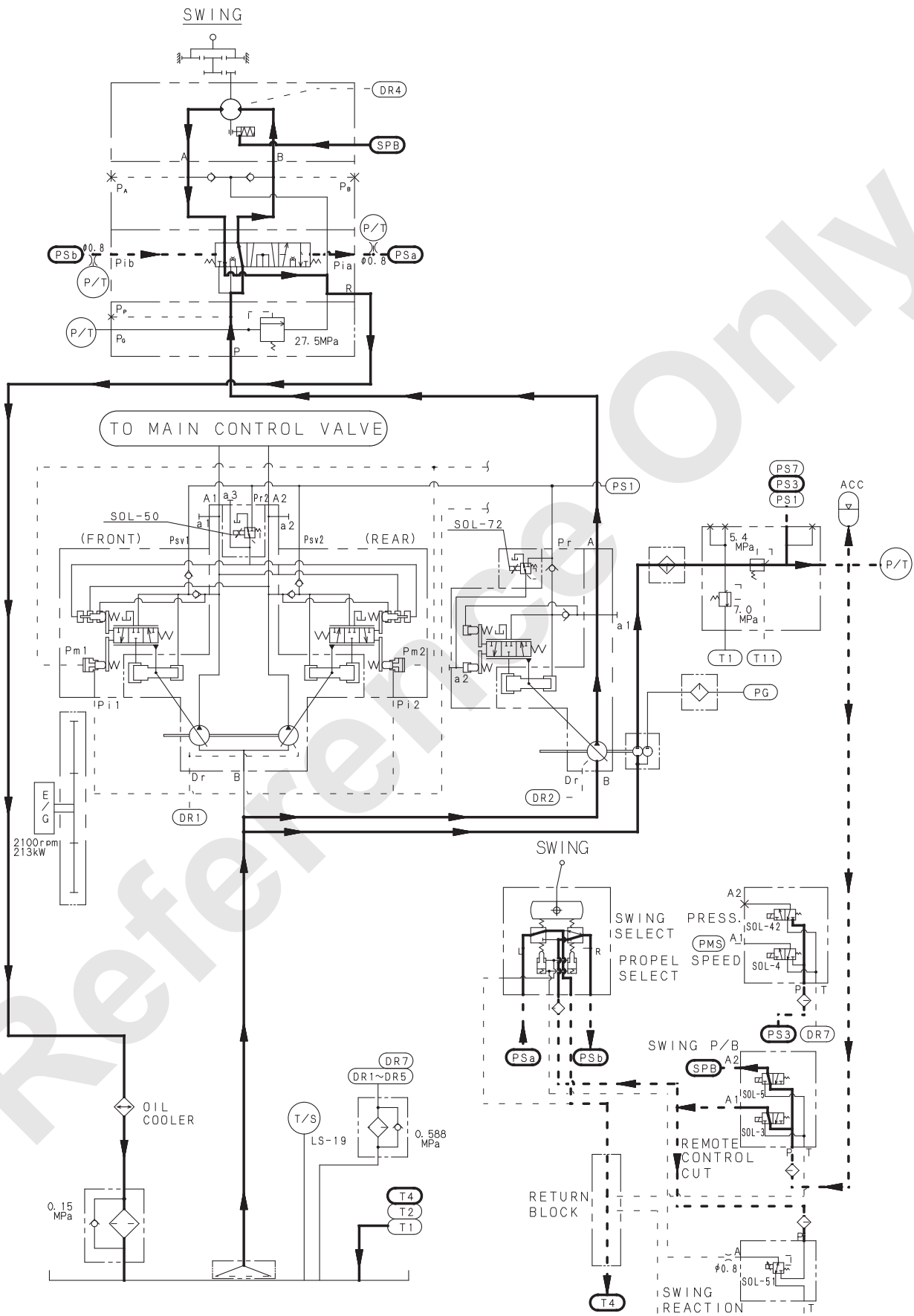

8. SWING SYSTEM

8.2.3 STOPPING

When the swing control lever is returned from the swing position to the neutral position, the control pressure from the remote control valve is shut off, and the control valve spool (A) returns to neutral.

As a result, the main pressurized oil from the swing pump returns to the tank with no load.

Although oil supply to the swing motor is cut off, return oil circulates within the motor and valve.

Therefore motor continues to rotate with its inertia.

(The swing brake is released.)

To stop the swing motion, turn the swing control lever gently to the opposite direction to generate the brake pressure at the swing motor outlet port by the pump pressure.

STOP (Neutral Free Mode)

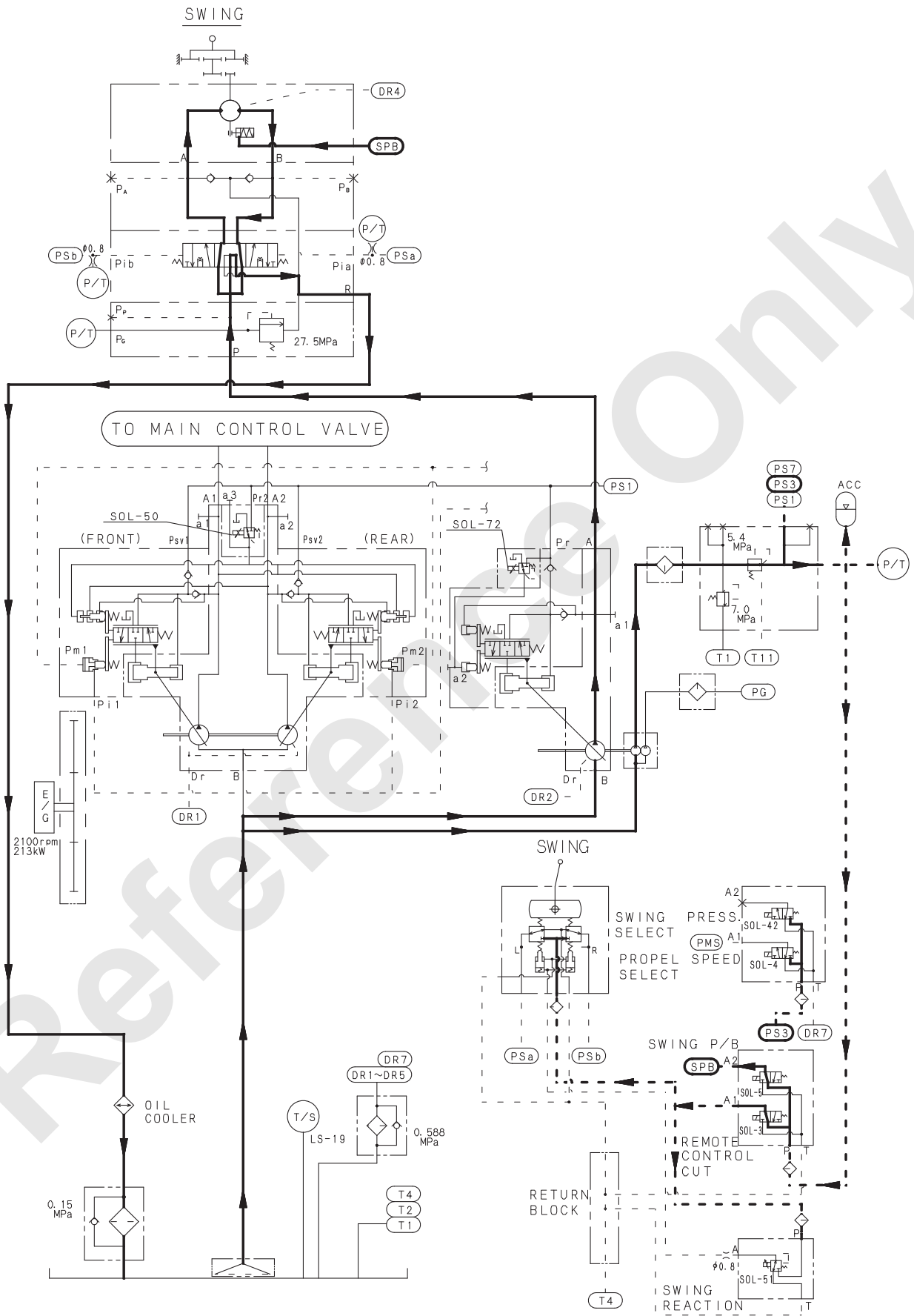

This page is blank for editing convenience.

8.3 SWING REDUCTION UNIT

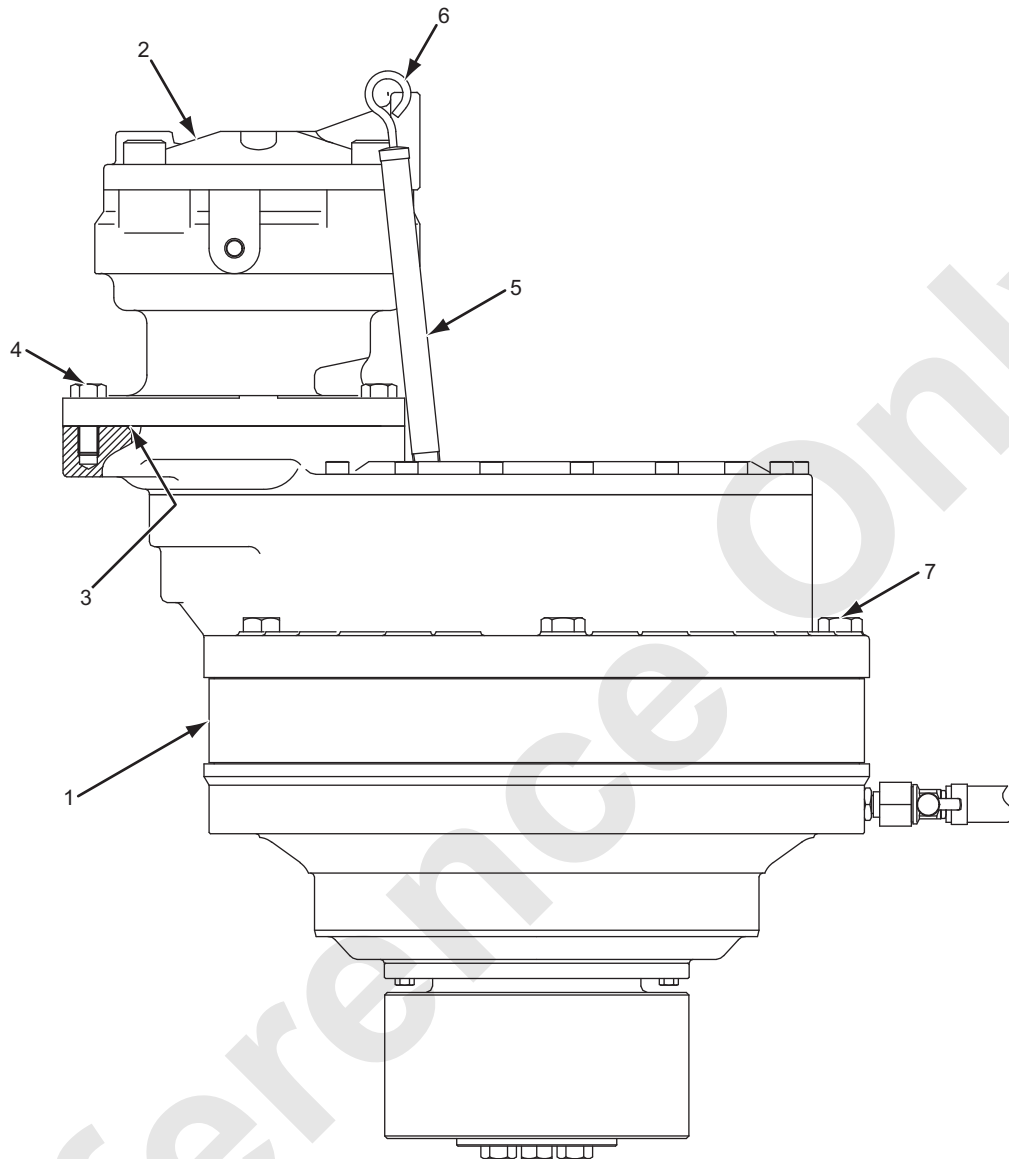

Item	Name	Tightening Torque	Weight
1	Reduction unit	-	396 kg (873 lbs)
2	Motor	-	64 kg (141 lbs)
3	O-Ring	-	-
4	Bolt	M16 X 45 mm / 145 to 177 N-m (107 to 131 lbs-ft)	-
5	Tube	-	-
6	Level gauge	-	-
7	Bolt	M20 X 140 mm / 504 to 616 N-m (372 to 454 lbs-ft)	-

8. SWING SYSTEM

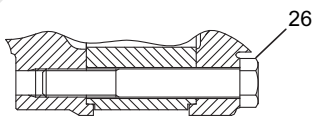
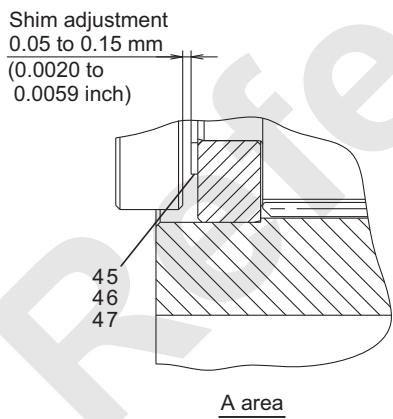
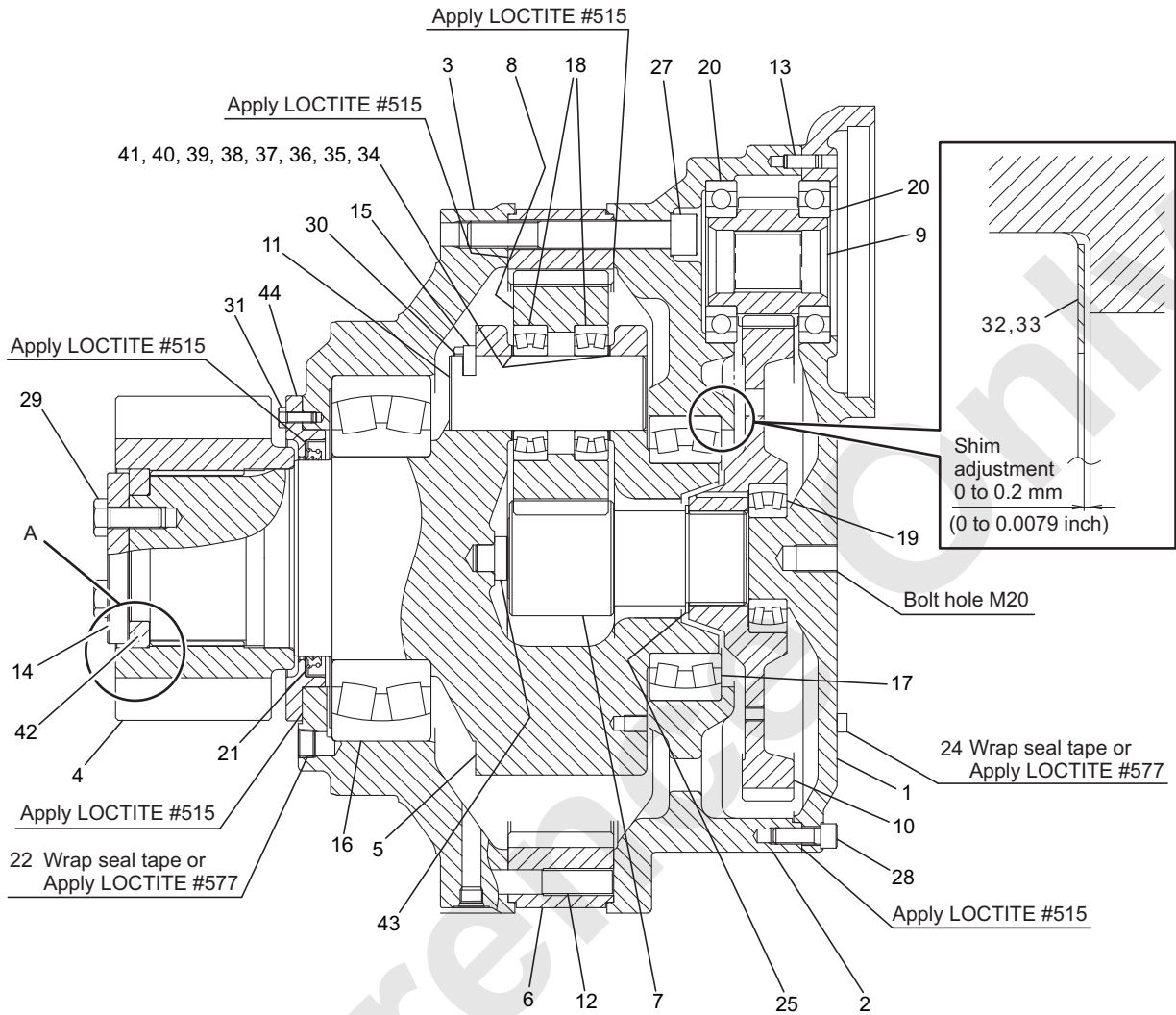

1. Housing	17. Bearing	34. Shim (t=1.1)
2. Housing	18. Bearing	35. Shim (t=1.2)
3. Housing	19. Bearing	36. Shim (t=1.3)
4. Pinion	20. Bearing	37. Shim (t=1.4)
5. Shaft	21. Oil seal	38. Shim (t=1.5)
6. Ring gear	22. Plug	39. Shim (t=1.6)
7. Sun gear	24. Plug	40. Shim (t=1.7)
8. Pinion	25. Snap ring	41. Shim (t=1.8)
9. Pinion	26. Capscrew	42. Spacer
10. Gear	27. Capscrew	43. Thrust button
11. Pin	28. Capscrew	44. Retainer
12. Pin	29. Capscrew	45. Shim (t=0.1)
13. Pin	30. Capscrew	46. Shim (t=0.2)
14. Plate	31. Capscrew	47. Shim (t=0.3)
15. Keeper plate	32. Shim (t=0.2)	
16. Bearing	33. Shim (t=0.5)	

TIGHTENING TORQUE

Item	Name	Size	Tightening Torque N-m (lbs-ft)
22	Plug	PT1/2	64.7 to 73.5 (47.7 to 54.2)
24	Plug	PT3/4	98 to 118 (72.3 to 87.0)
26	Capscrew	M20 X 140	504 to 616 (371.7 to 454.3)
27	Capscrew	M20 X 150	504 to 616 (371.7 to 454.3)
28	Capscrew	M12 X 35	109 to 133 (80.4 to 98.1)
29	Capscrew	M16 X 40	261 to 319 (192.5 to 235.3)
30	Capscrew	M10 X 25	63 to 77 (46.5 to 56.8)
31	Capscrew	M8 X 20	31.5 to 38.5 (23.2 to 28.4)

Apply LOCTITE #242 to capscrew.

Assembly total weight : Approx. 396 kg (873 lbs) (Without motor)

8.4 SWING BEARING

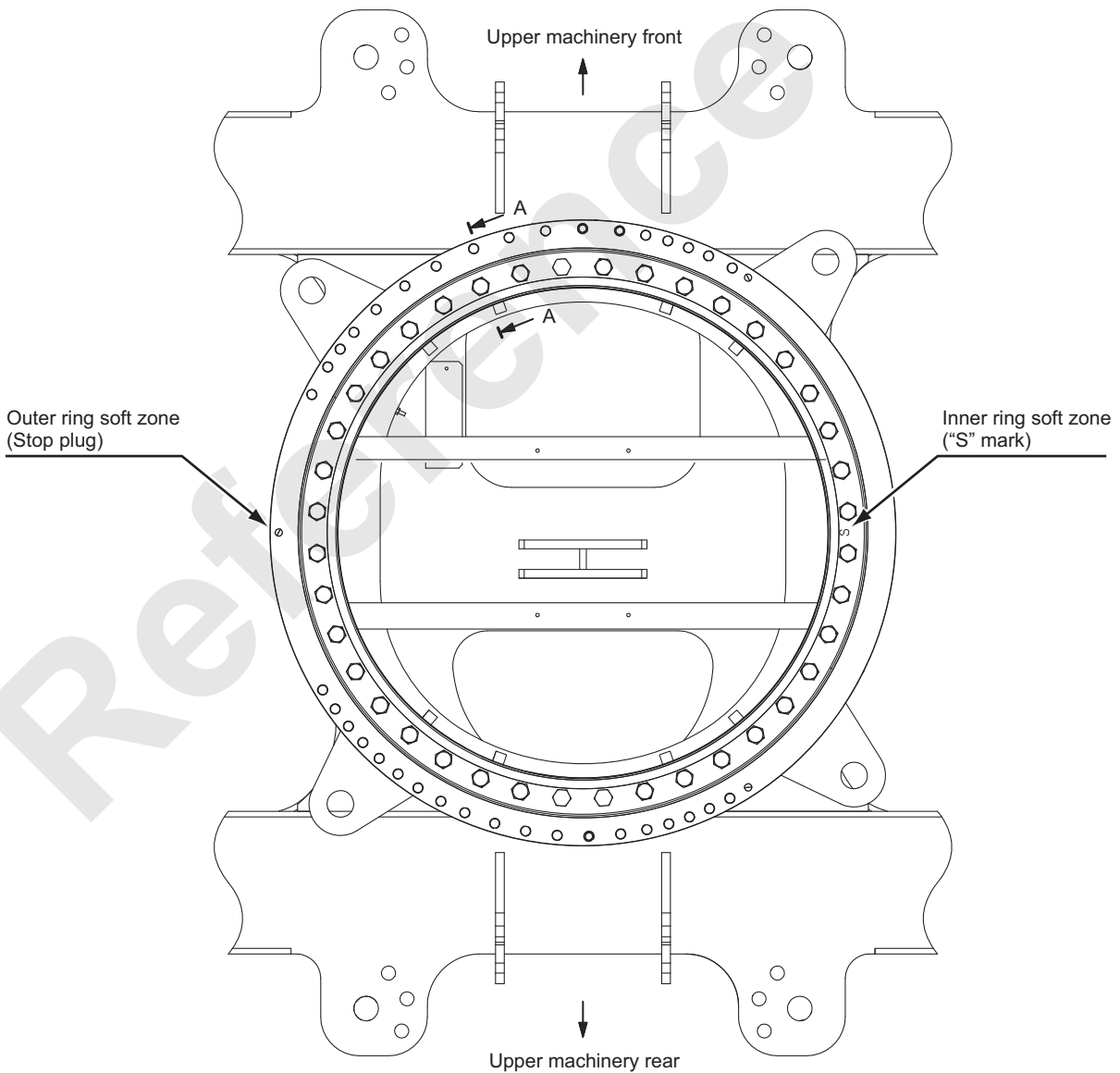
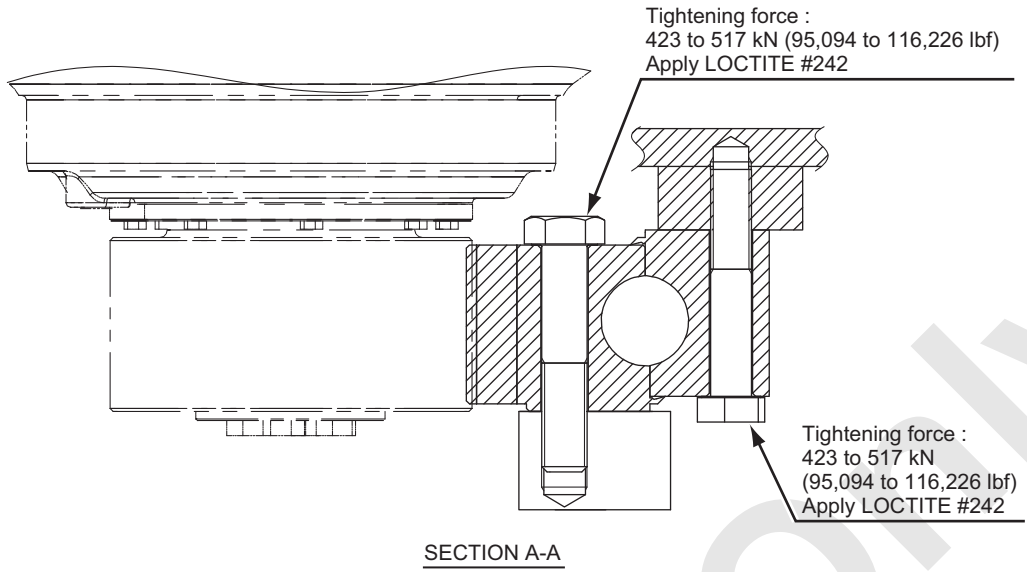

BOLT TIGHTENING PROCEDURE

Lower frame side

1. Tighten 2 bolts which are positioned 180 degrees apart each other on the lower frame side with 147 N-m (108 lbs-ft) torque.
2. Tighten 2 bolts which are positioned 90 degrees apart from the previously tightened bolts.
3. Tighten diagonally positioned bolts with 147 N-m (108 lbs-ft) torque.
4. Tighten all bolts with 423 to 517 kN (95,094 to 116,226 lbf) tightening force.
(Tightening torque shall be checked with axial force measurement.)
Ref : tightening torque 2.5 to 3.06 kN-m
(1,844 to 2,257 lbs-ft)
5. After tightening to the lower frame, apply enough amount of molybdenum sulfide grease (Shell Alvania EP grease LF) on the gear tooth face.

Upper frame side

1. Tighten 4 bolts on both side of front, both side of rear of the upper frame with 147 N-m (108 lbs-ft) torque.
2. Tighten 2 bolts which are positioned 90 degrees apart from the previously tightened bolts.
3. Tighten diagonally positioned bolts with 147 N-m (108 lbs-ft) torque.
4. Tighten all bolts with 423 to 517 kN (95,094 to 116,226 lbf) tightening force.
(Tightening torque shall be checked with axial force measurement.)
Ref: tightening torque 2.5 to 3.06 kN-m
(1,844 to 2,257 lbs-ft)

Bearing inner ring soft zone (S mark position) shall be positioned against the lower machinery as shown.

Assembly total weight : Approx. 1,013 kg (2,233 lbs)
--

8.5 SWING LOCK

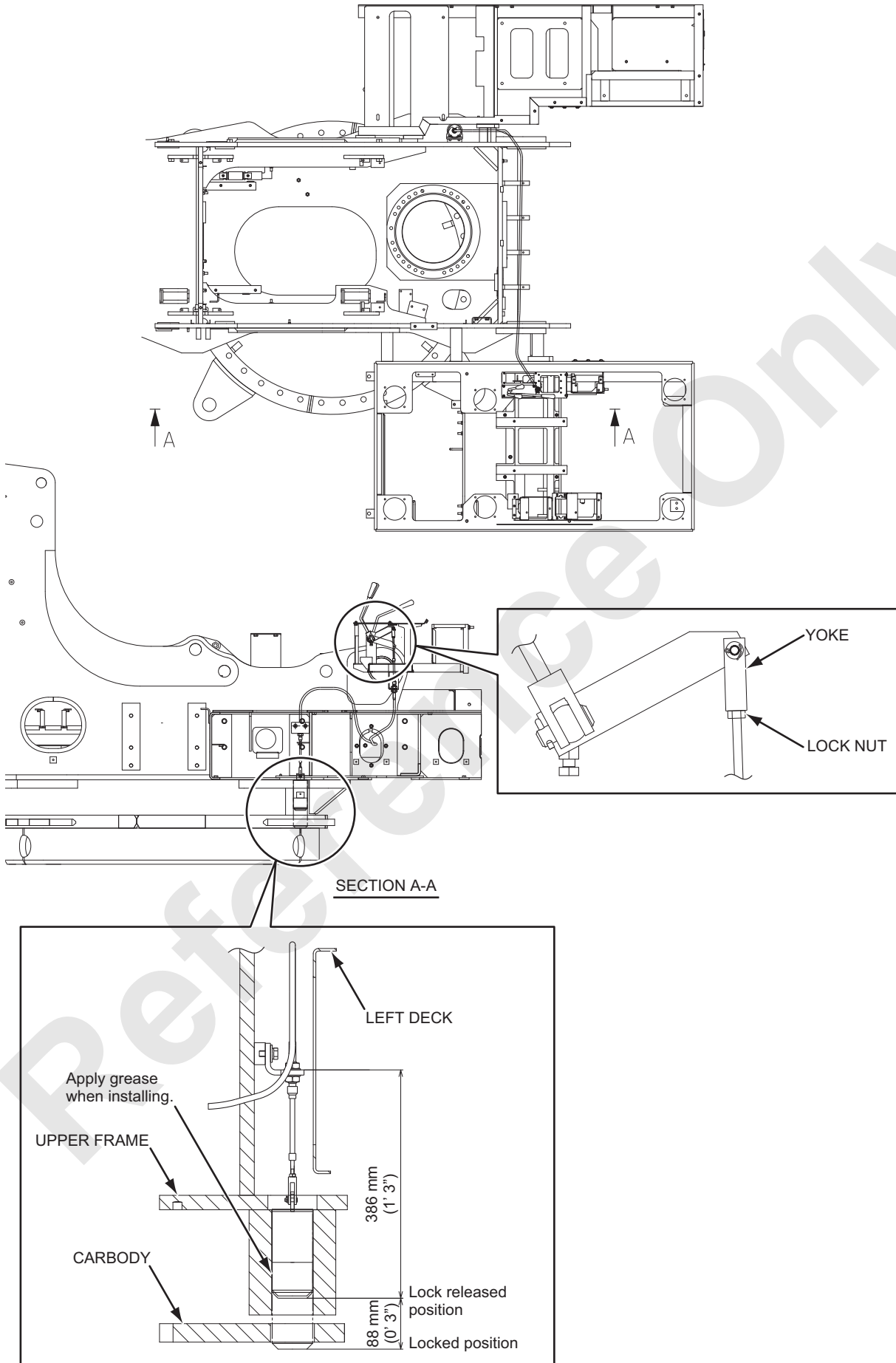

9. PROPEL SYSTEM

Reference Only

Reference Only

9.1 APPARATUS AND LOCATION OF COMPONENTS

The Propel system consists of the main pump, the main control valves, the propel motors, the propel reduction units, the upper/lower rollers, the drive tumblers, idlers and shoes.

Pressurized oil from the main pumps (No.1 and No.2 pumps installed on the power divider) is controlled through the 2 main control valves. This pressurized oil flows through the swivel joint and then into the left and right propel motors to run their respective motors.

A spring set/hydraulic release disk brake is installed on each of the two propel motors (built-in type).

As for circuit diagram and function of propel (right forward), stop, refer to P.9-11 to 9-15.

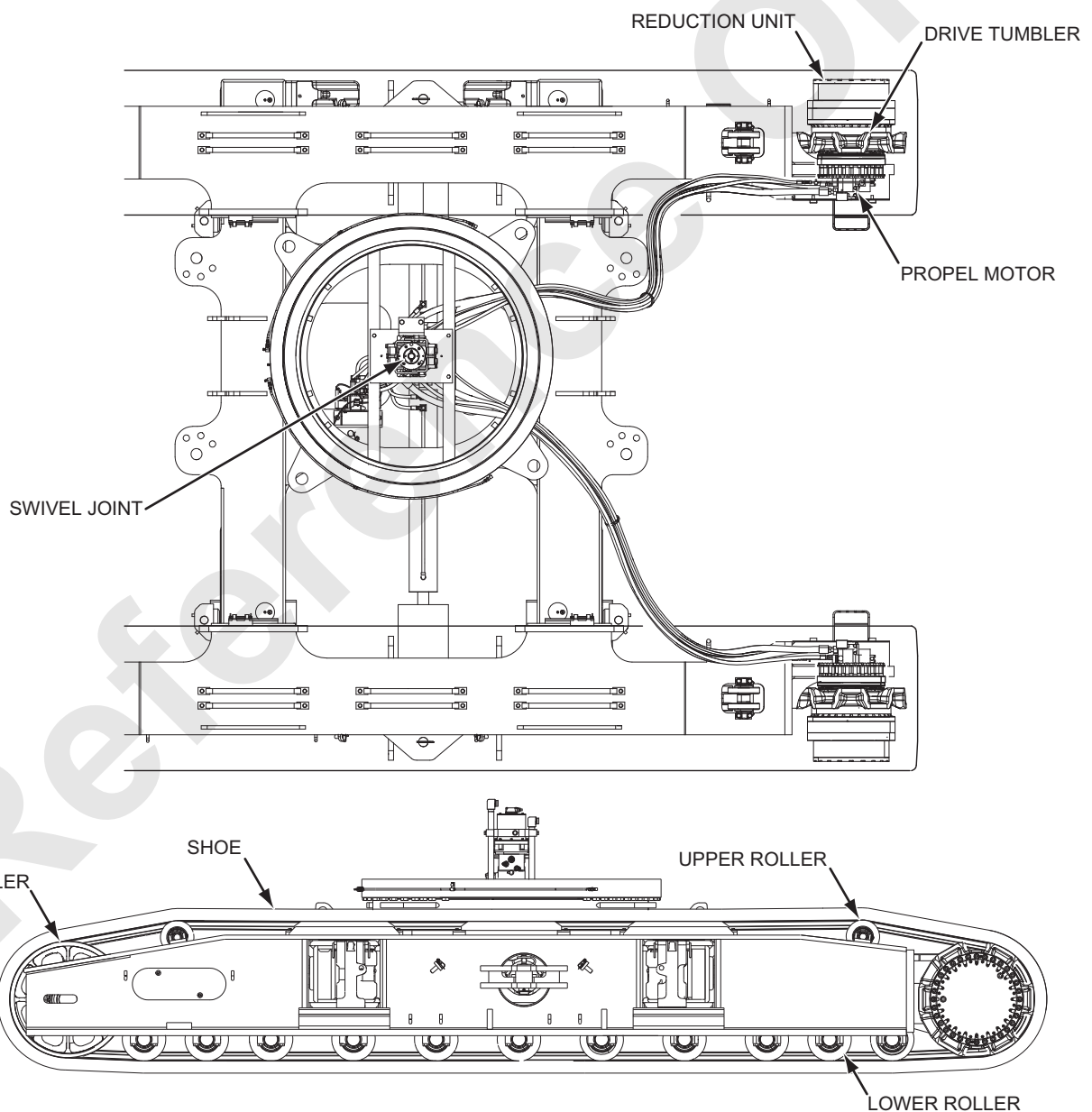

9.2 PROPEL REDUCTION UNIT

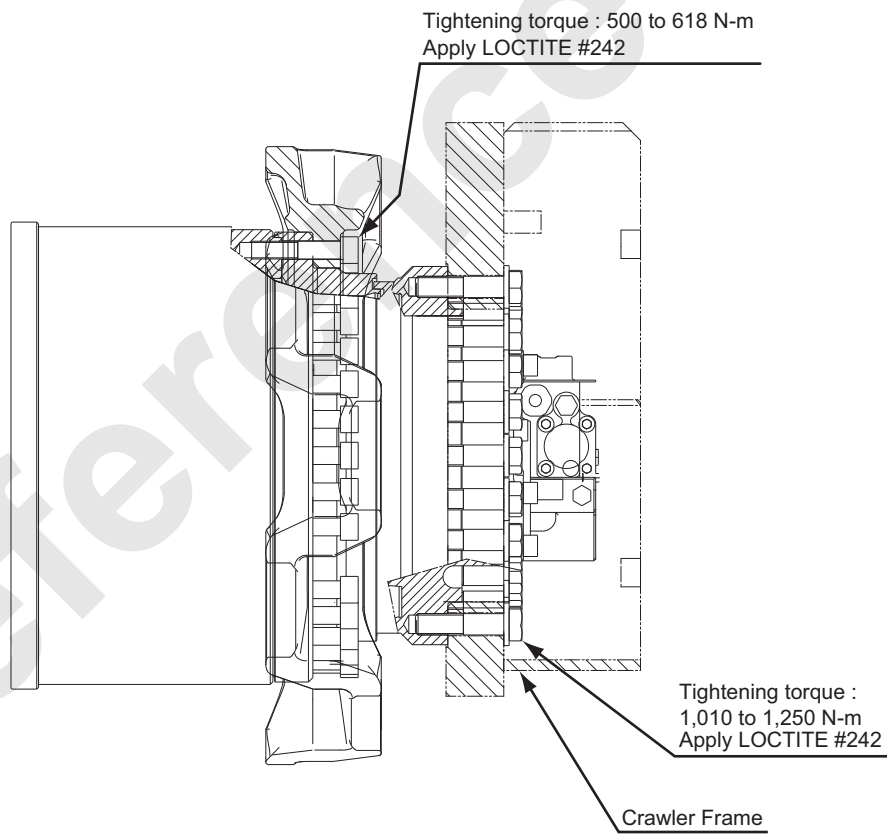
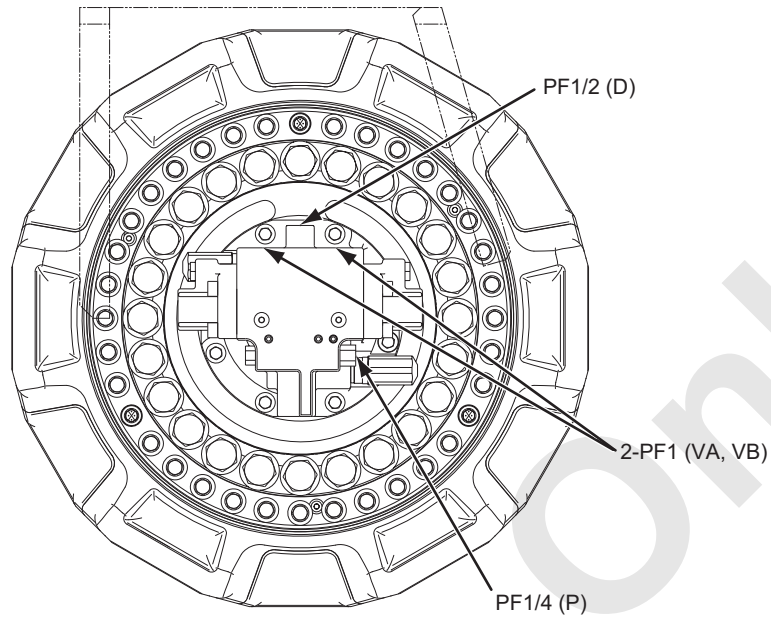

Assembly Weight : Approx. 510 kg

This page is blank for editing convenience.

Reference Only

9. PROPEL SYSTEM

9.2.1 MOTOR AND REDUCTION UNIT

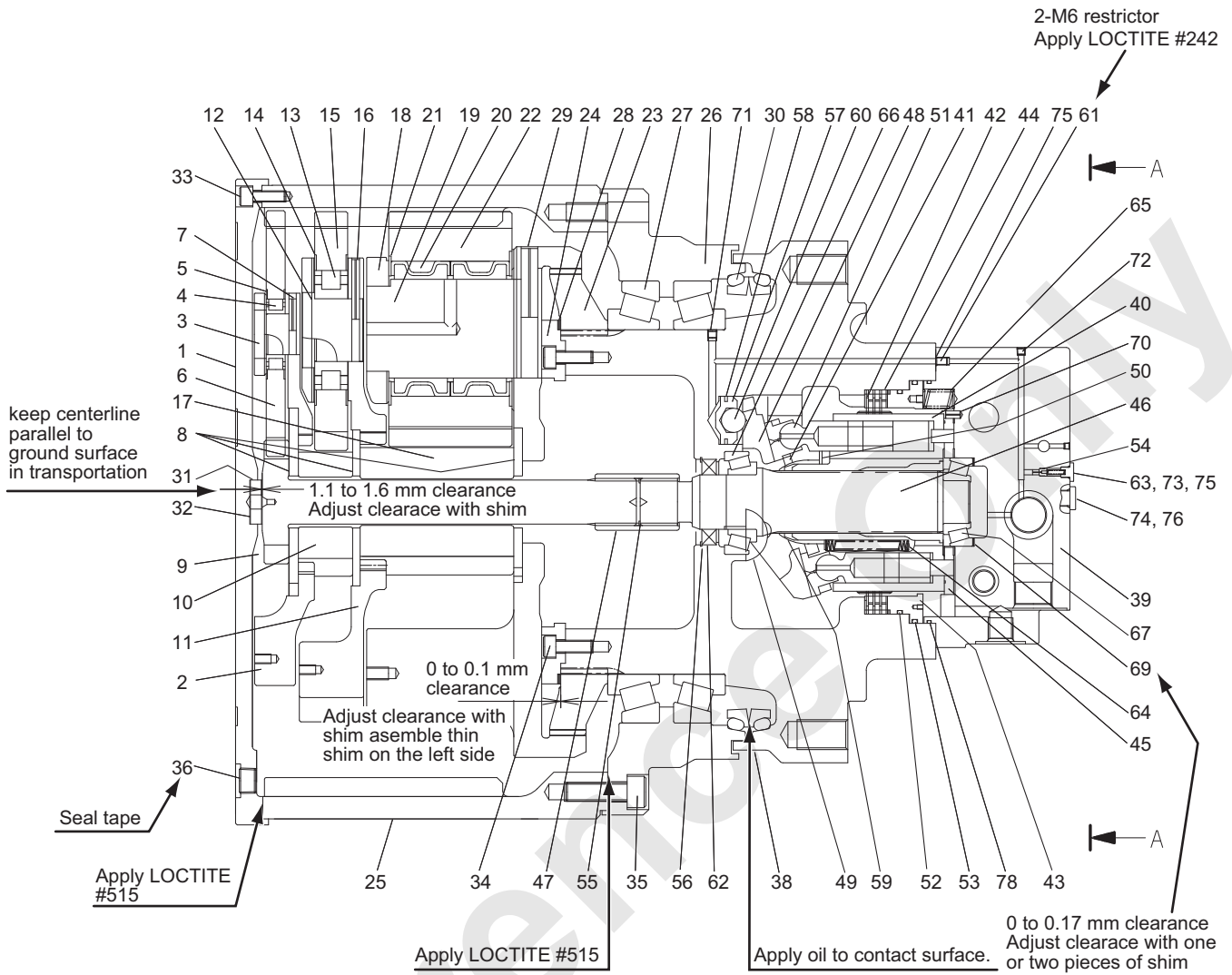

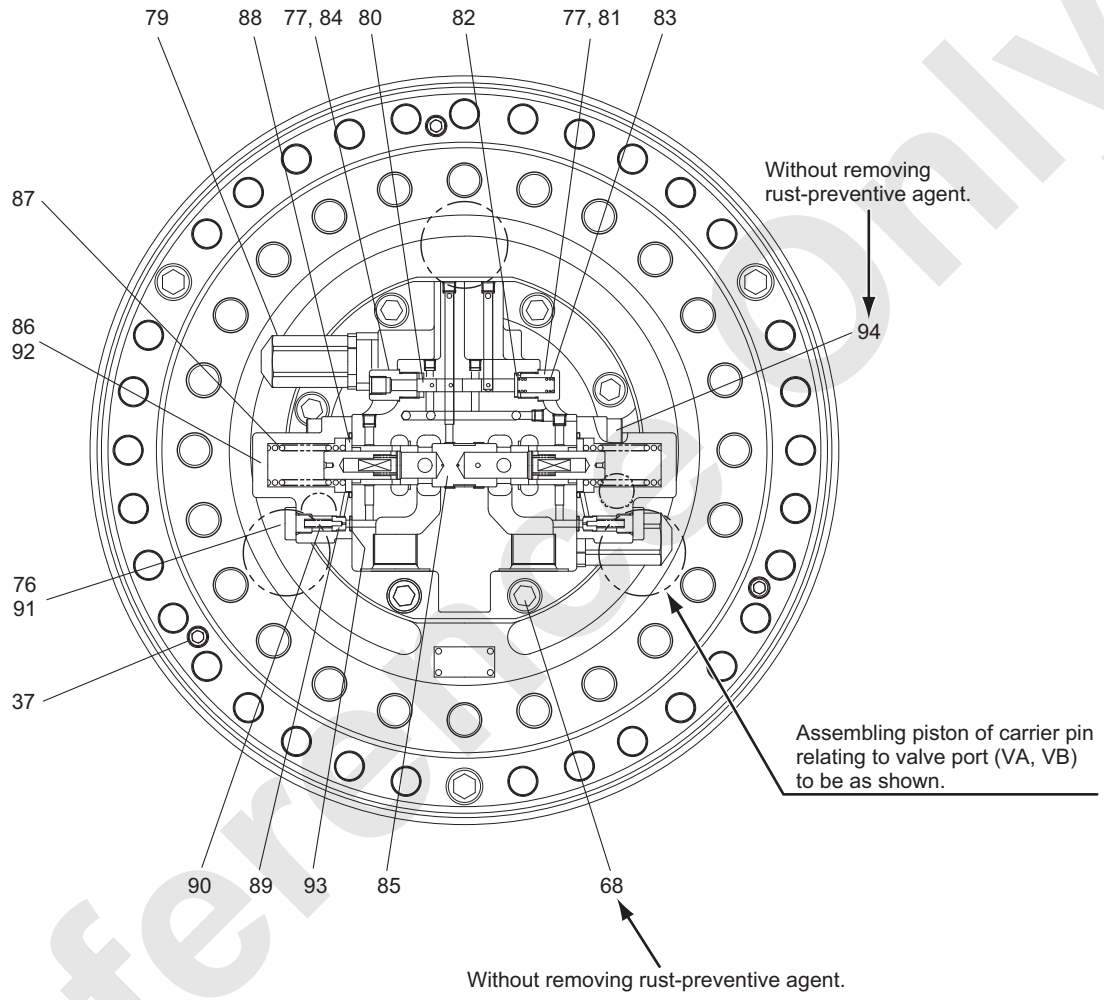

VIEW A-A

9. PROPEL SYSTEM

- | | | |
|--------------------------|------------------------------|---------------------------|
| 1. Cover | 33. Capscrew | 65. Spring of brake |
| 2. Carrier | 34. Capscrew | 66. Bearing |
| 3. Carrier pin | 35. Capscrew | 67. Bearing |
| 4. Bearing | 36. Capscrew | 68. Hex. socket head bolt |
| 5. Thrust washer | 37. Capscrew | 69. Shim |
| 6. Planetary gear | 38. Casing | 70. Parallel pin |
| 7. Spring pin | 39. Rear cover | 71. Plug |
| 8. Spacer | 40. Cylinder block | 72. Plug |
| 9. Sun gear | 41. Shoe retainer | 73. Plug |
| 10. Sun gear | 42. Friction plate | 74. Plug |
| 11. Carrier | 43. Brake piston | 75. O-ring |
| 12. Carrier pin | 44. Separated plate | 76. O-ring |
| 13. Bearing | 45. Valve plate | 77. O-ring |
| 14. Thrust washer | 46. Shaft | 78. O-ring |
| 15. Planetary gear | 47. Coupling | 79. Overload relief assy |
| 16. Spring pin | 48. Swash plate | 80. Spool |
| 17. Sun gear | 49. Pivot | 81. Plug |
| 18. Carrier | 50. Spring holder | 82. Spring holder |
| 19. Carrier pin | 51. Piston assy | 83. Spring |
| 20. Niddle bearing | 52. D-ring | 84. Connector |
| 21. Thrust washer | 53. D-ring | 85. Spool assy |
| 22. Planetary gear | 54. Check valve | 86. Cover |
| 23. Coupling | 55. Retaining ring of C type | 87. Spring |
| 24. Holder | 56. Retaining ring | 88. Spring holder |
| 25. Ring gear | 57. Shifter piston | 89. Restrictor |
| 26. Housing | 58. Piston seal | 90. Spring |
| 27. Taped roller bearing | 59. Ball joint | 91. Plug |
| 28. Shim | 60. Ball | 92. O-rings |
| 29. Spring pin | 61. M6 restrictor | 93. O-ring |
| 30. Floating seal | 62. Oil seal | 94. Socket head cap screw |
| 31. Thrust ring | 63. Spring of check valve | |
| 32. Shim | 64. Spring of cylinder | |

TIGHTENING TORQUE TABLE

Item	Name	Size	Tightening Torque (N-m)	Remarks
33	Capscrew	M10 X 30	61.74 to 75.46	Apply LOCTITE #242
34	Capscrew	M12 X 30	106.2 to 129.8	Apply LOCTITE #242
35	Capscrew	M16 X 45	264.6 to 323.4	Apply LOCTITE #242
36	Capscrew	R (PT) 3/4	88.29 to 107.91	
37	Capscrew	M8 X 35	30.38 to 38.22	Apply LOCTITE #242
68	Hex. socket head bolt	M16 X 45	206.5 to 253.5	
71	Plug	NPT 1/16	11.74 to 15.66	Apply LOCTITE #242
72	Plug	NPT 1/16	9.81 to 11.8	
73	Plug	G (PF) 1/8	12.74 to 16.66	
74	Plug	G (PF) 1/4	26.46 to 32.34	
79	Overload relief assy		98.1 to 118	
81	Plug	G3/8	49 to 58.8	
84	Connector		49 to 58.8	
91	Plug		24.5 to 29.4	
94	Socket Head cap screw	M12 X 35	88.29 to 107.91	

Assembly weight : Approx. 508 kg

9.3 ADJUSTMENT

If the crawler shoes are too tight, the shoes wear quickly and a connection between two shoes could break. On the other hand, if the shoes are too loose, the shoes may ride off the drive sprocket and idler wheel during the travel operation.

To prevent these occurrence from happening, it is required to adjust shoe tension.

To adjust shoe tension, proceed as follows :

1. Move the machine forward about the crawler length so that the slackening of the crawler shoes appear on the upper side of the crawler.
2. Remove all the shims from shim pack (A).
3. Set the hydraulic jack in the position between the bracket and block of the side frame. Operate the jack to push the idler wheel, and remove the slackening of the shoes.
4. Insert the shims removed from pack (A) in step2. into the vacant room of pack (B). Insert the remaining shims into pack (A).
5. Remove the hydraulic jack. Store spare shims in the shim pack (A).

Note

Equalize the tension in right and left crawler tracks.

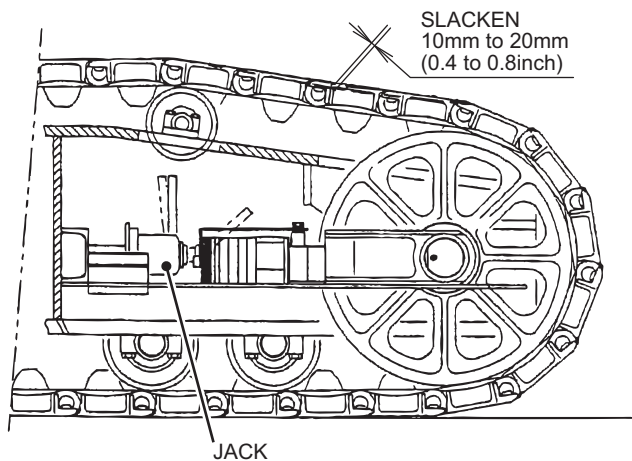
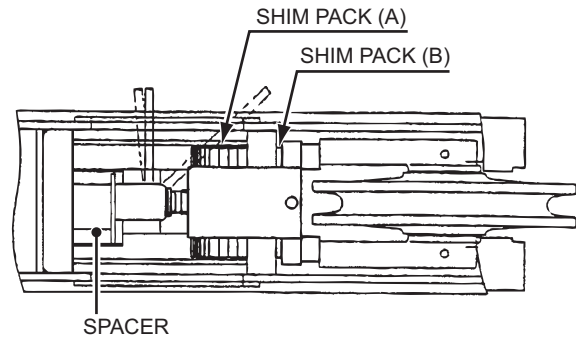

9.4 CONSTRUCTION AND FUNCTION

9.4.1 HYDRAULIC SCHEMATIC

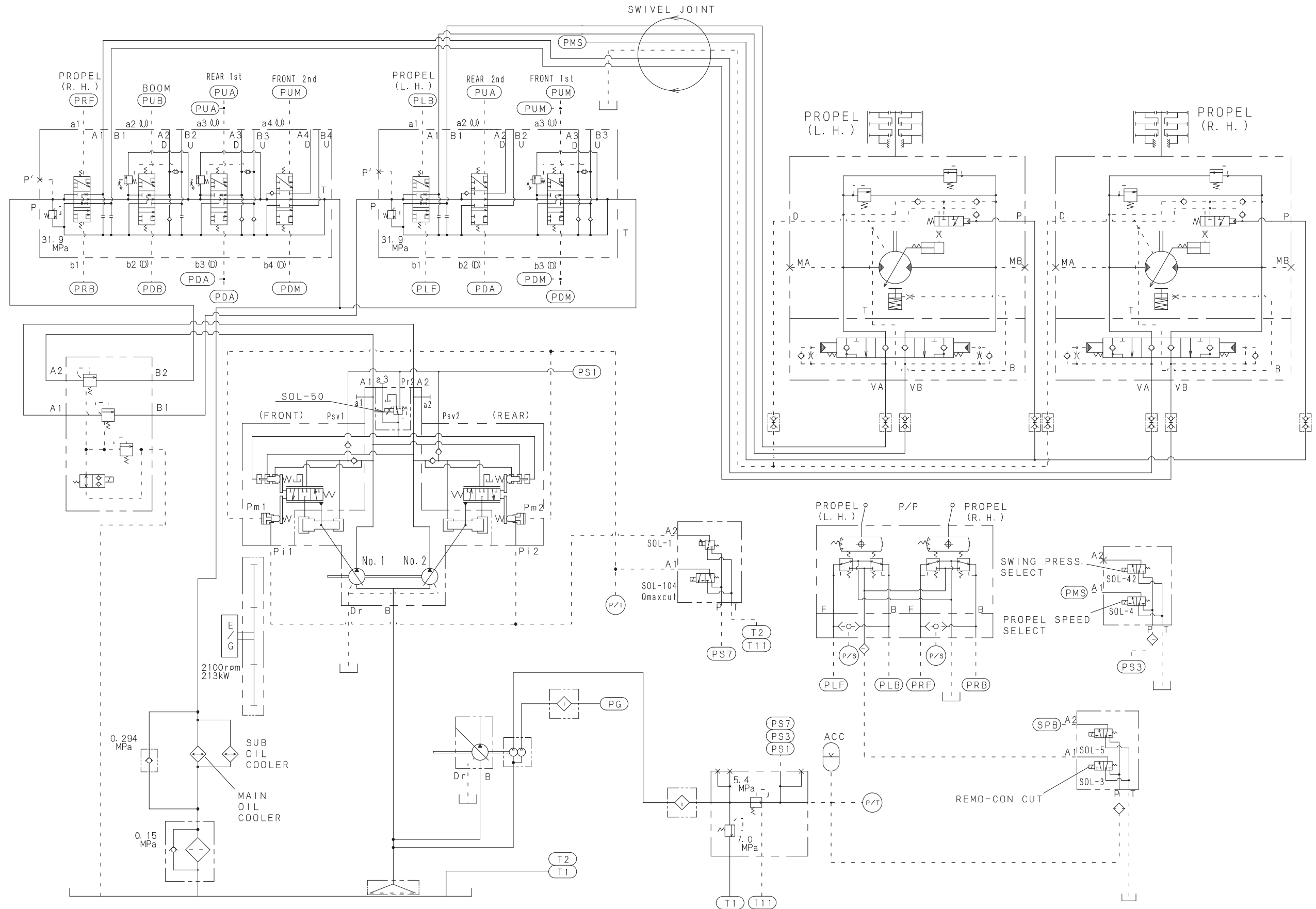

9.4.2 PROPELLING (RIGHT SIDE FORWARD)

Propelling the right and/or left sides and to the forward and reverse are basically the same operation.

We will use a right side forward operation as the example here.

Pressurised oil from the No.1 pump is directed into the control valve.

The oil from the control pump, however, goes through the accumulator and into the propel-circuit's remote control valve, (The function lock lever remains in the "Operation" position (SOL-3 : On position).)

When the right propel control lever is shifted to "forward", the control oil runs through the remote control valve to the control valve's [PRF] port to shift the spool of the propel section.

The pressurized oil directed by the control valve then goes through the swivel joint and run into the propel motor. At the same time, this oil runs into the pilot of the brake valve and the brake cylinder.

The oil in this cylinder releases the brake, and the oil in the brake valve pilot moves the spool, so that the pressurized oil releases the mechanical and hydraulic brake.

The pressurized oil that activated in the propel motor is free to return to the reservoir.

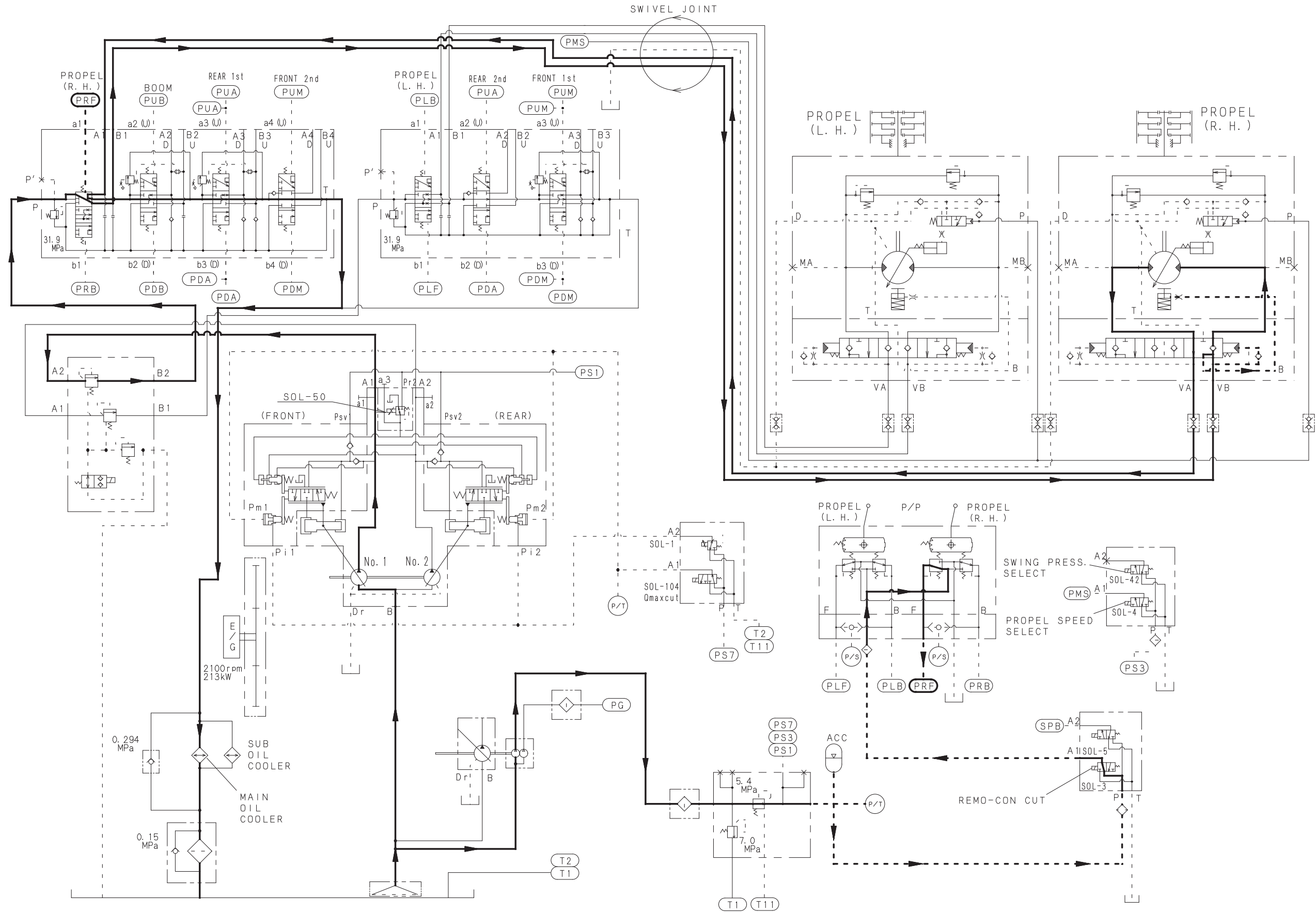

PROPEL (R.H. FORWARD)

9.4.3 STOPPING

When the right propel control lever is shifted back to neutral from propel position, the flow from the remote control valve is cut and the spool of the control valve repositions itself. At the same time, the pilot pressure on the propel brake valve is discontinued, and the spool in the brake valve also repositions itself.

Inertia may continue momentarily to rotate the propel motor. This creates negative pressure on the supply side and high pressure on the return side. Therefore, the supply side is connected to the reservoir in neutral. If extreme pressure develops on the return side, an over load relief valve will open to protect the circuit.

At the same time, the pressurized oil in the brake cylinder is returned to the reservoir, and the parking brake engages slowly.

Reference

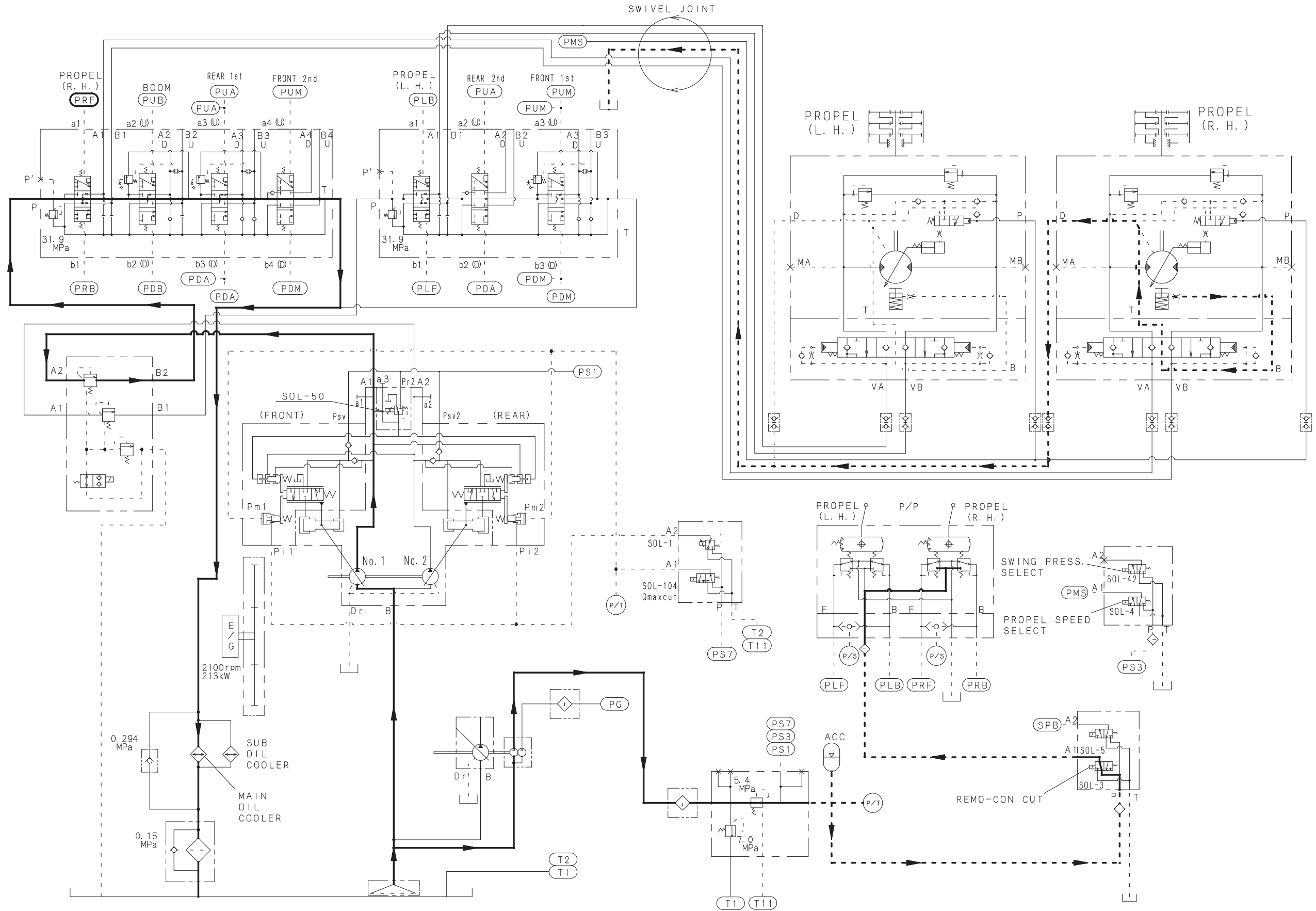

PROPEL STOPPING

Reference Only

This page is blank for editing convenience.

10. ELECTRIC SYSTEM

Reference Only

10. ELECTRIC SYSTEM



Before unplugging or plugging in the connector, be sure to shut off the power supply (set the starter switch to the OFF position).

When unplugging the connector, hold it with both hands and draw it straight, while pressing down the catch.

DO NOT pull on the cable.

Otherwise, the inner conductors can be damaged.

NEVER twist or pry the connector.

Otherwise, its internal female terminal will be expanded, leading to disconnection.

When plugging in the connector, fully insert it until the catch is engaged (clicks into position).

Otherwise, disconnection can occur later.

When performing a continuity test or voltage measurement on the connector, follow the procedure below.

Square connector

For easy measurement, place the measurement probes of the multimeter onto the pins of male side connector.

NEVER insert the probe of the multimeter into the socket of the female side connector.

Otherwise, disconnection can occur later.

Round waterproof connector

The male side connector has waterproof construction, and the measurement probe of the multimeter cannot touch its pins.

Therefore, place the measurement probes onto the terminals on the female side connector.

NEVER forcibly insert the measurement probe.

Otherwise, disconnection can occur later.

Short-circuiting across terminals inside a connector can damage electronic components.

Be absolutely careful to prevent short-circuit.

10.1 ELECTRICAL

10.1.1 ELECTRICAL WIRING SCHEMATIC

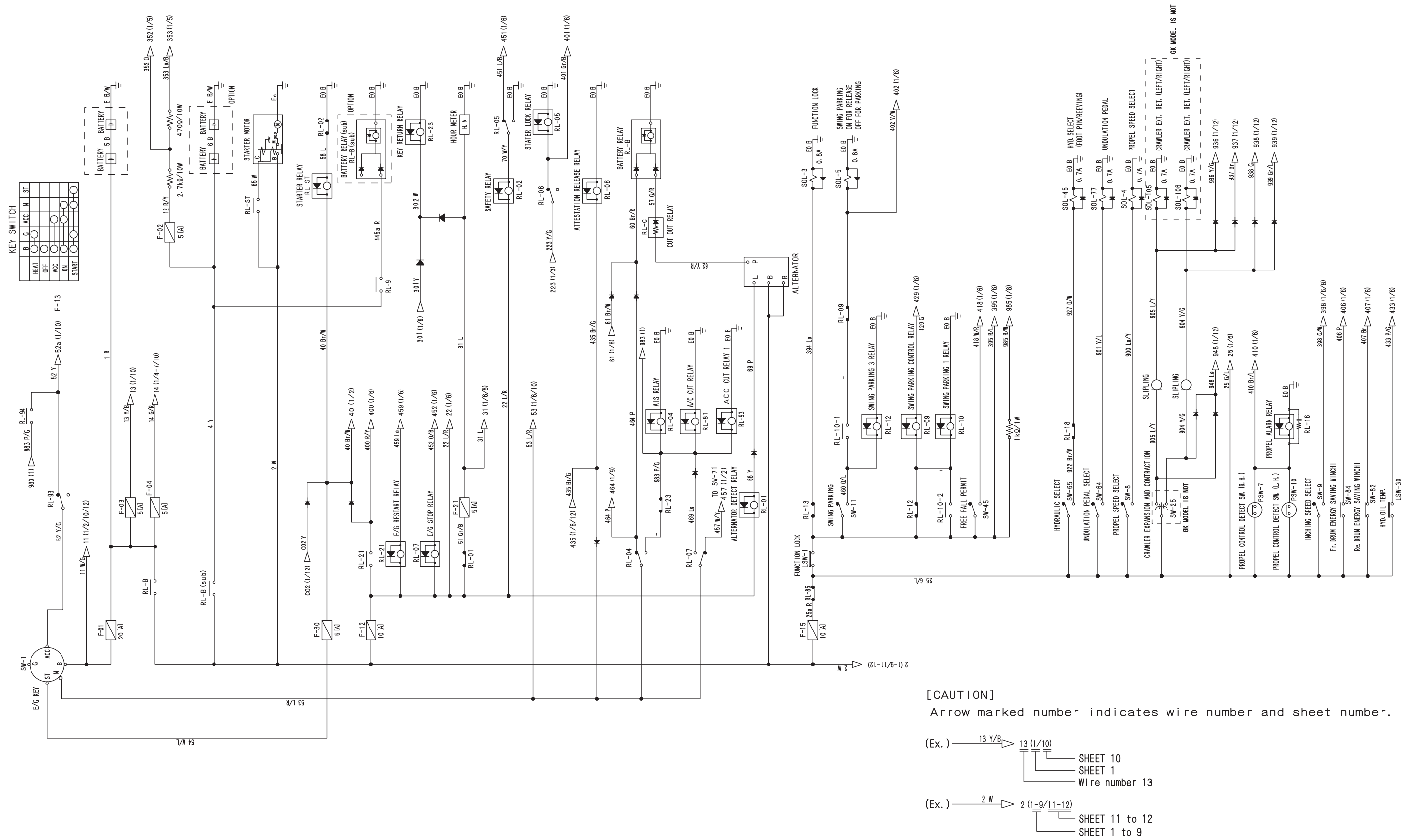

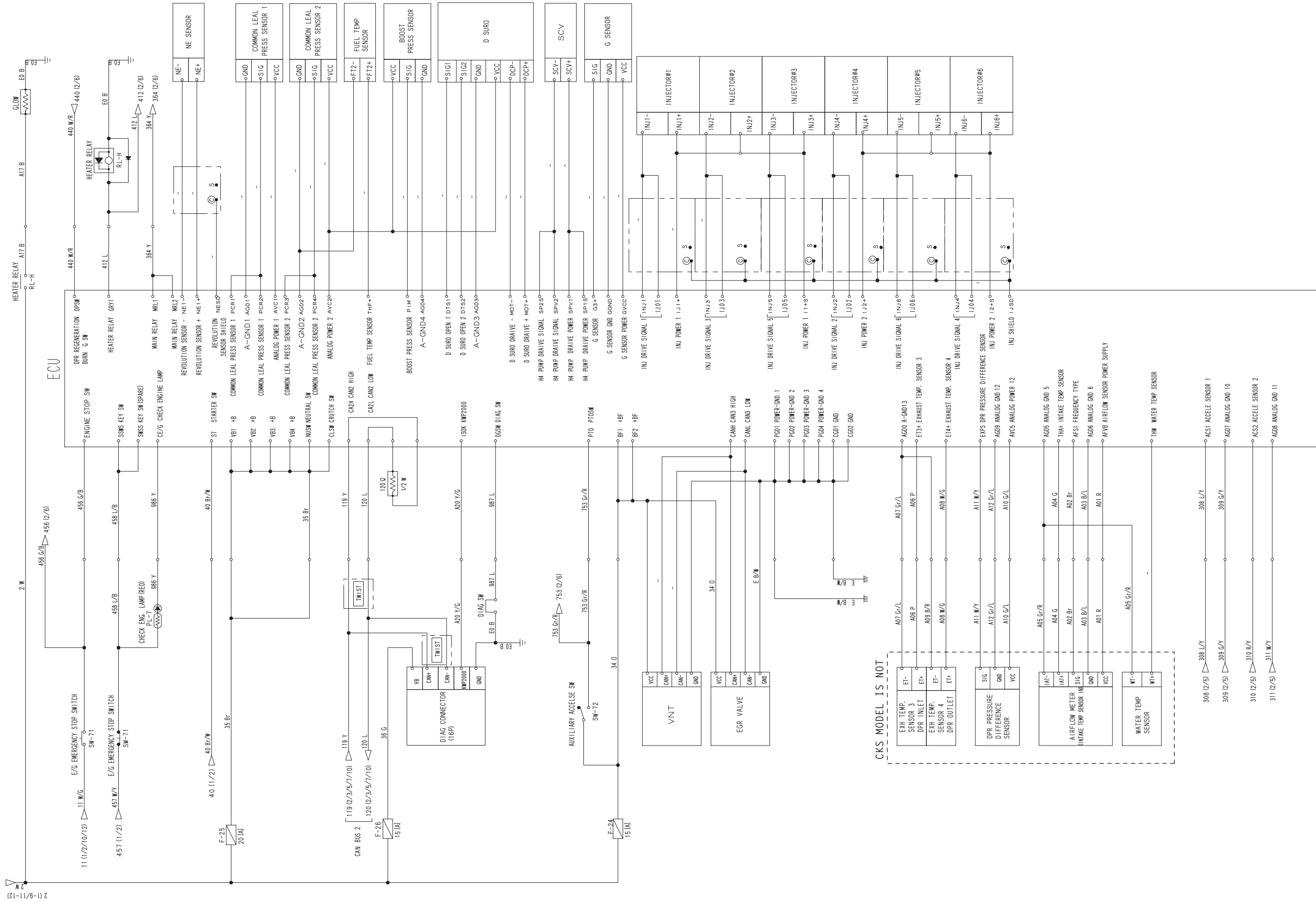

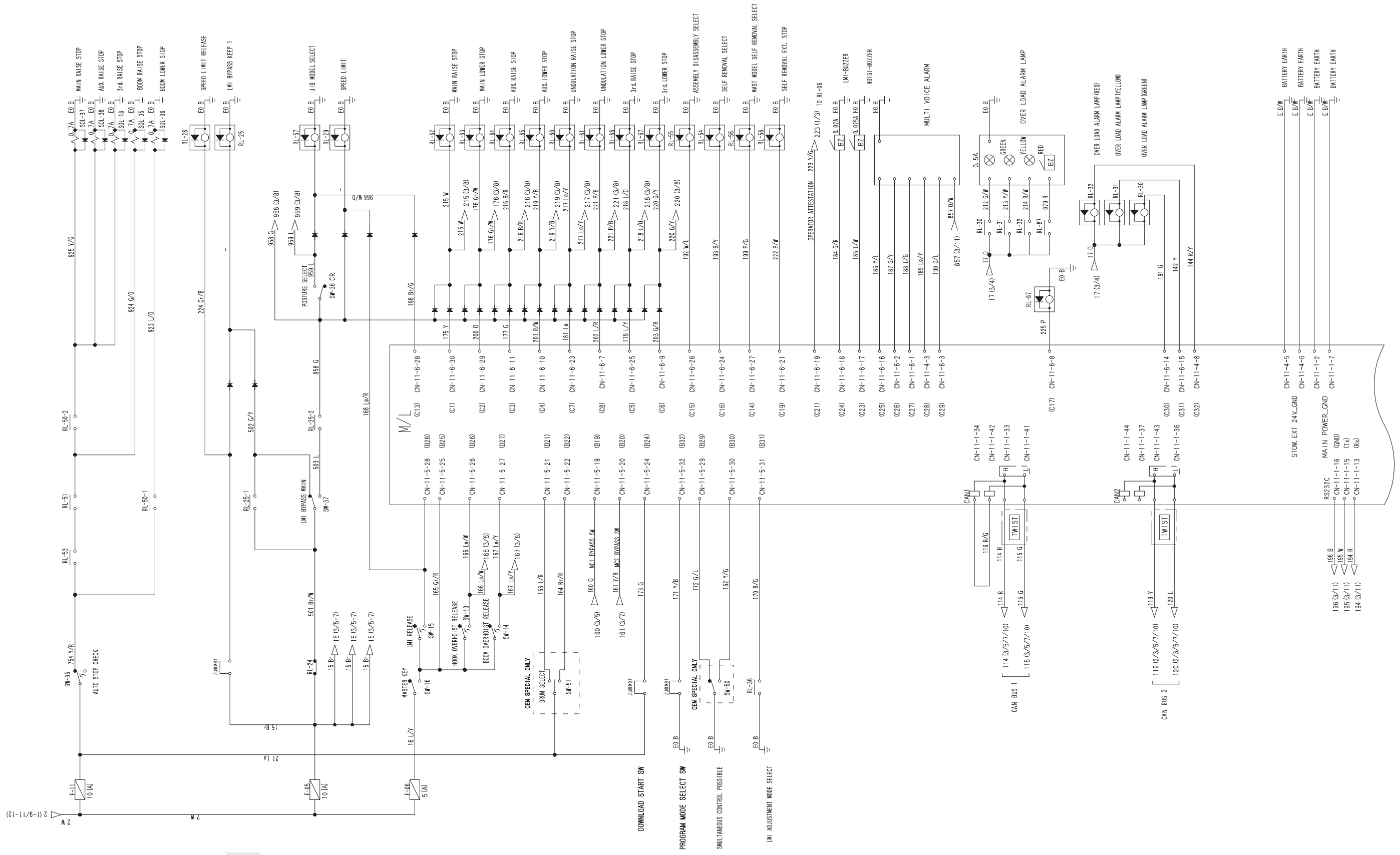

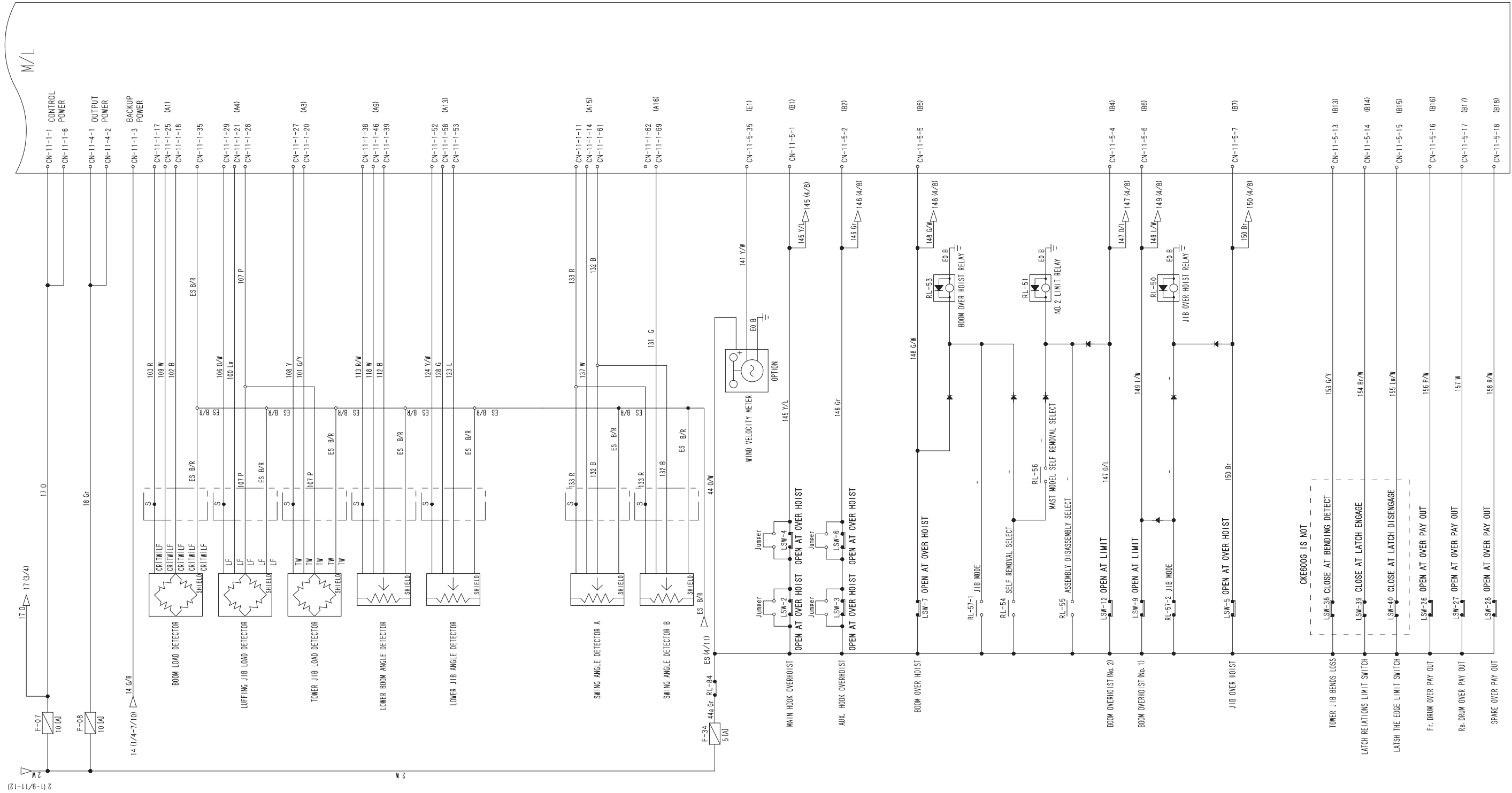

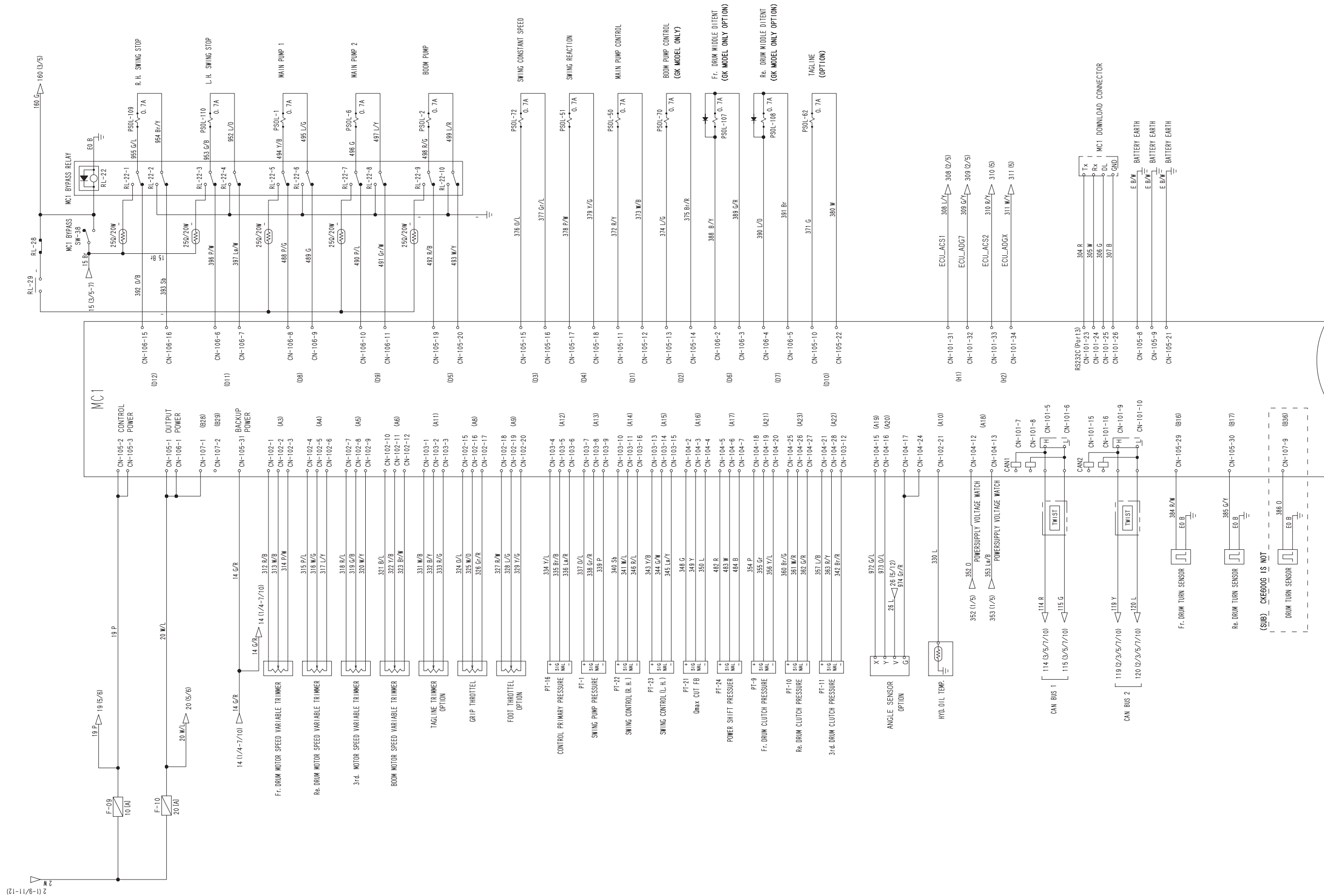

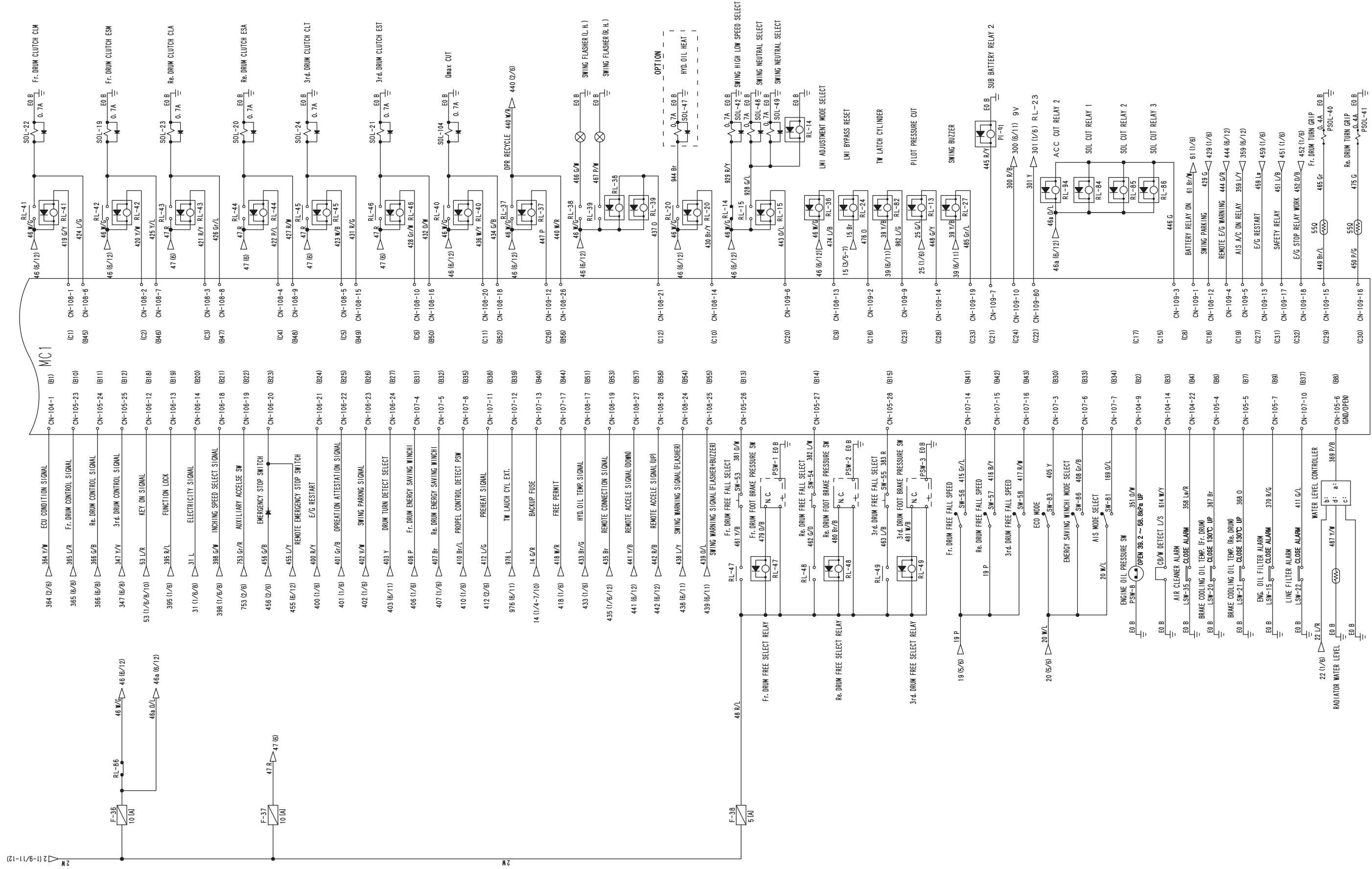

(6/18)

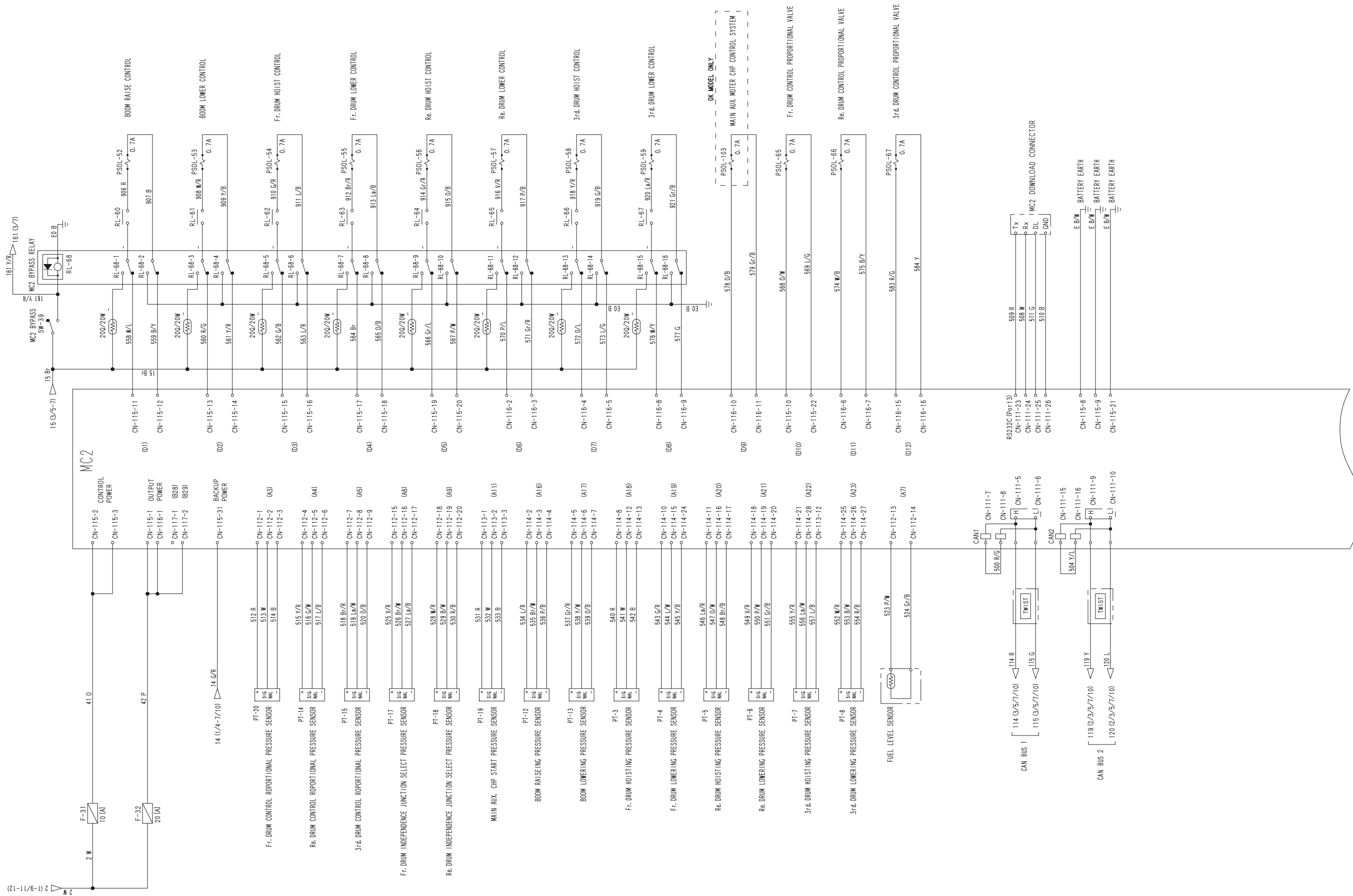

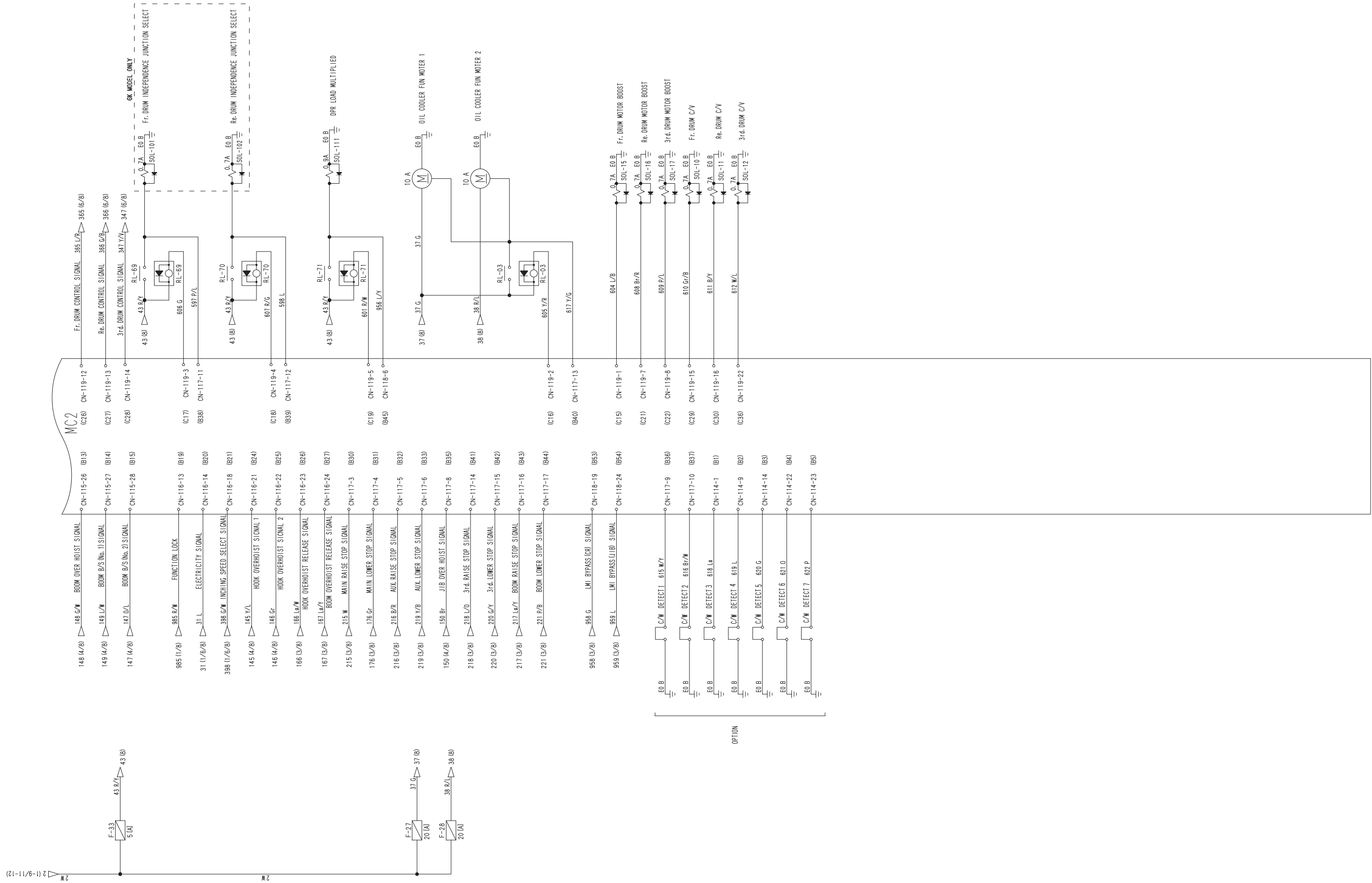

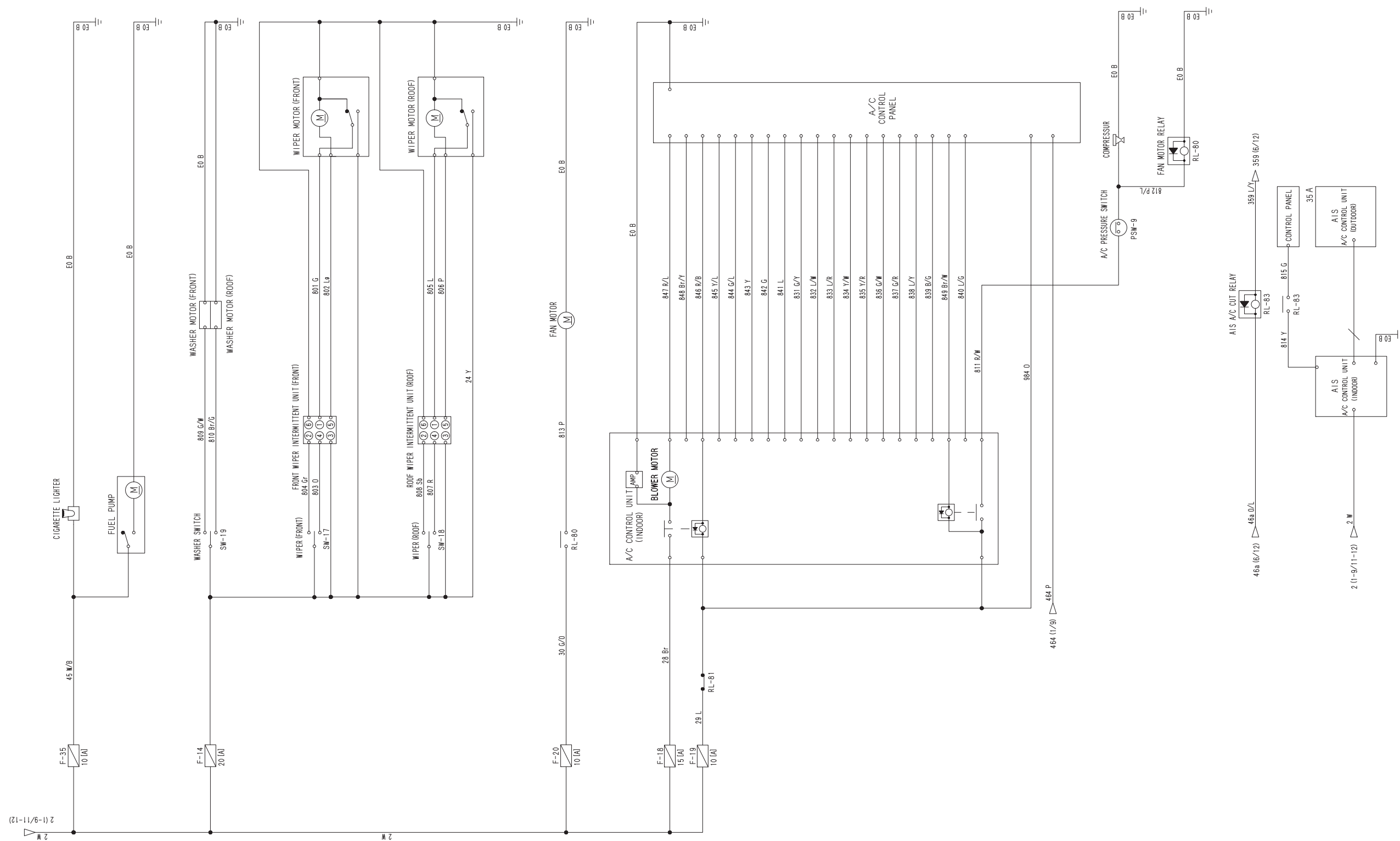

10. ELECTRIC SYSTEM

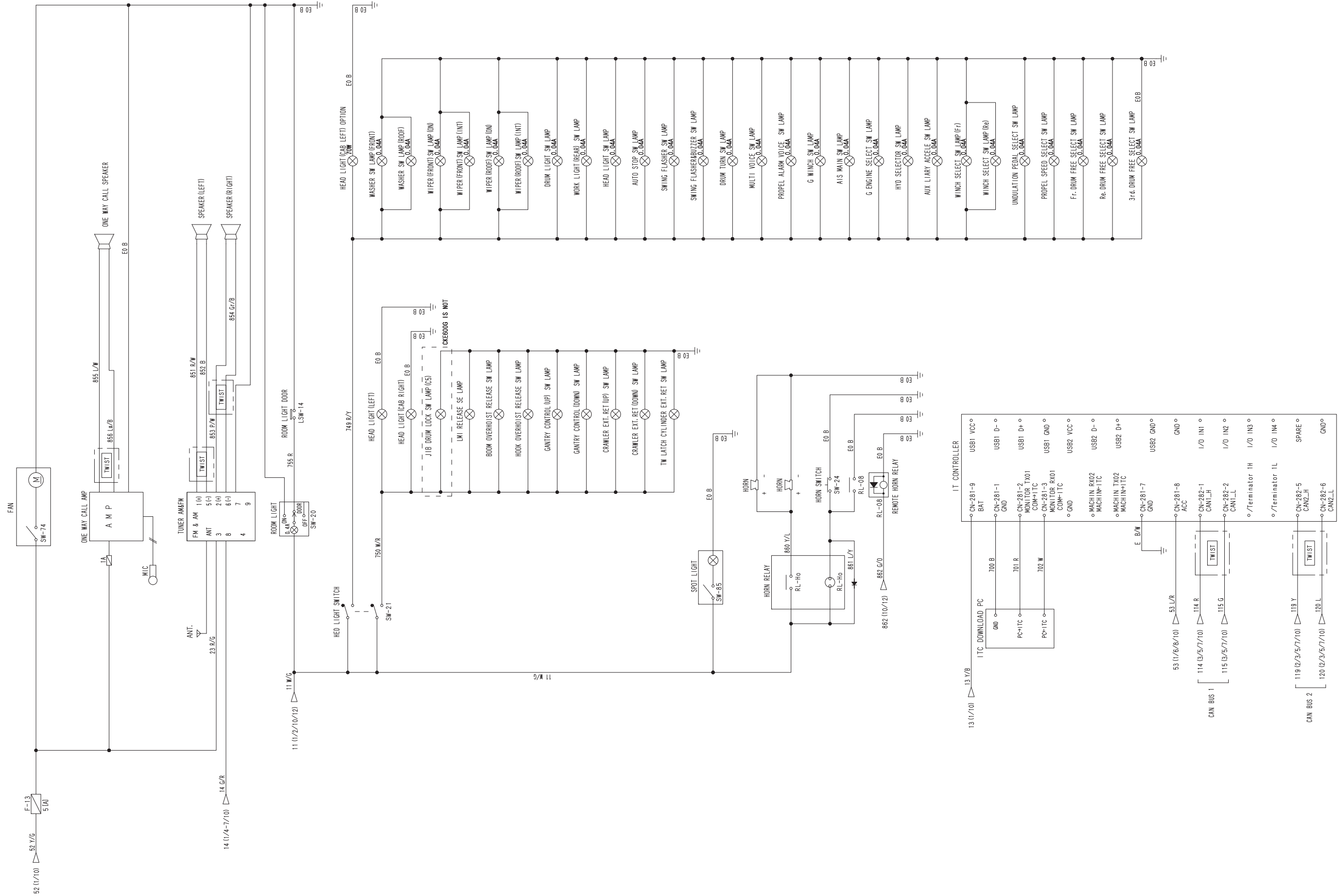

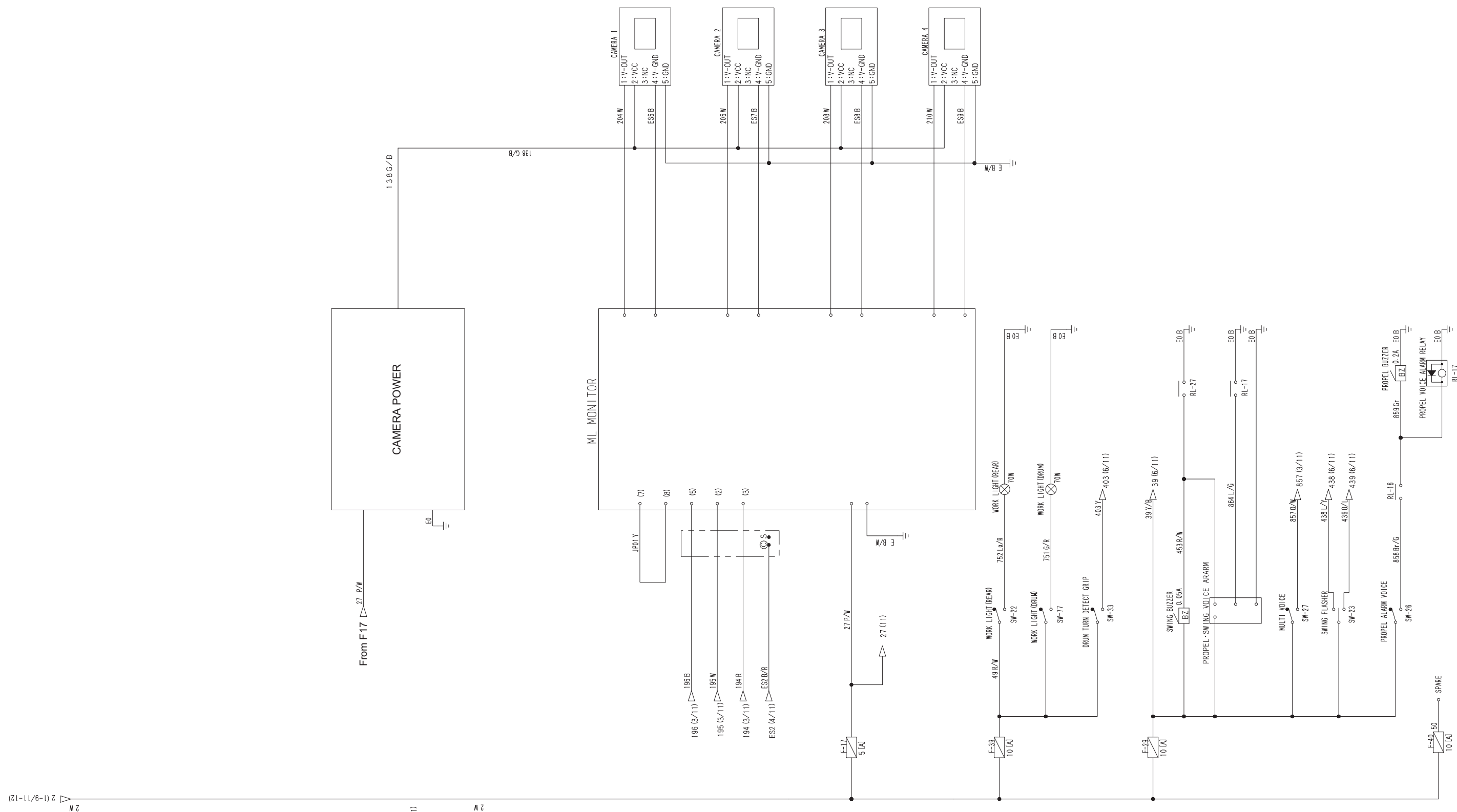

2 W 2 (1-9/11-12)

300 (6/11) 2 W

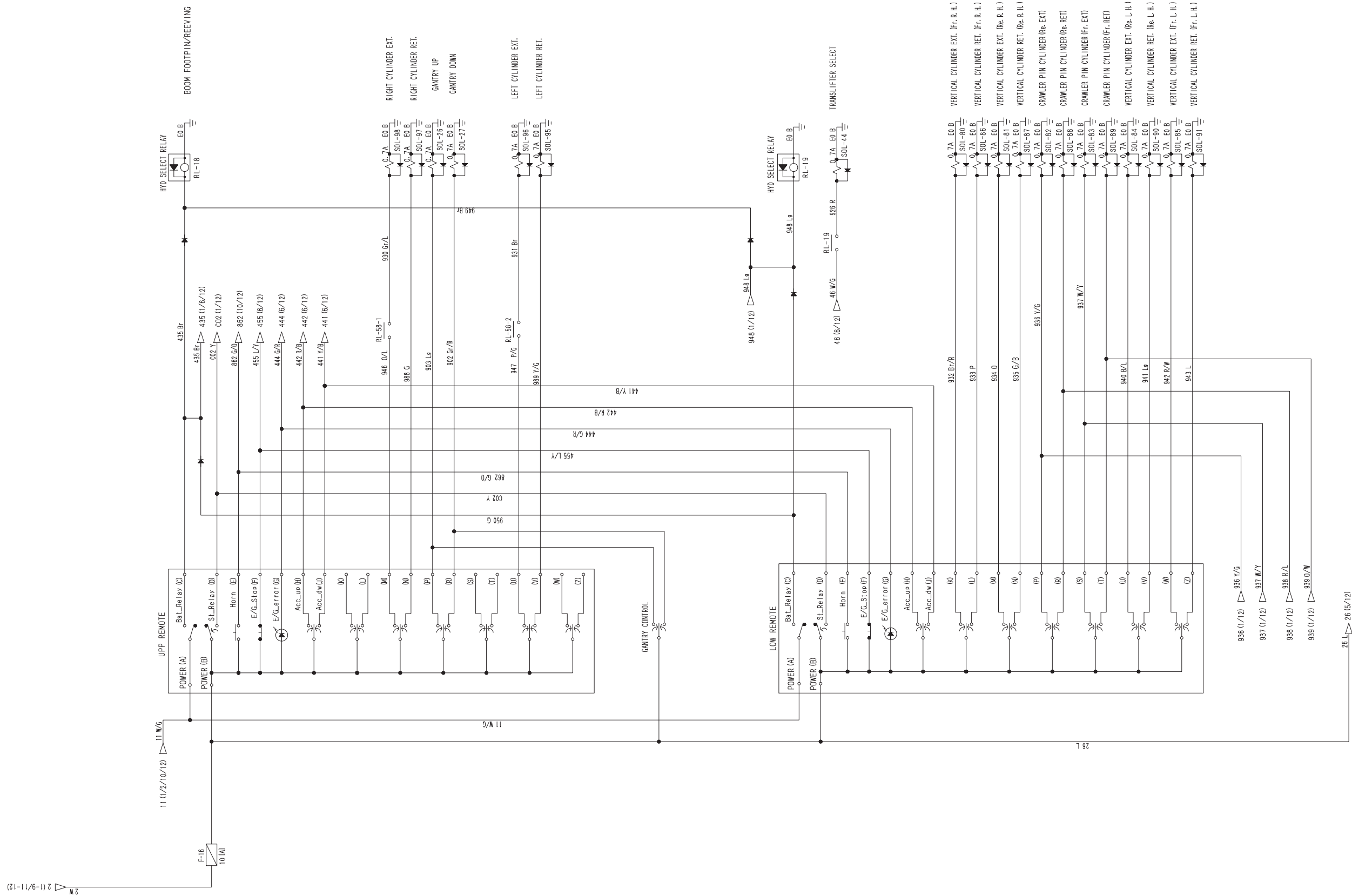

RELAY				
RL-NO.	COIL SHEET No.	TERMINAL SHEET No.	TYPE	U S E
RL-B (sub)	1	1	N O	BATTERY RELAY (sub)
RL-B	1	1	N O	BATTERY RELAY
RL-Ho	10	10	N O	HORN RELAY
RL-C	1		N O	CUT OUT RELAY
RL-H	2	2	N O	HEATER RELAY
RL-ST	1	1	N O	STARTER RELAY
RL-01	1	1	N C	ALTERNATOR DETECT RELAY
RL-02	1	1	N C	SAFETY RELAY
RL-03	8	8	N O	OIL COOLER MOTER
RL-04	1	1	N O N C	AIS RELAY
RL-05	1	1	N O N C	STATER LOCK RELAY
RL-06	1	1	N C	ATTESTATION RELEASE RELAY
RL-07	1	1	N O N C	E/G STOP RELAY
RL-08	10	10	N O	REMOTE HORN RELAY
RL-09	1	1	N C	SWING PARKING CONTROL RELAY
RL-10	1			SWING PARKING 1 RELAY
RL-10-1		1	N O	SWING PARKING 1
RL-10-2		1	N O	SWING PARKING 2
RL-12	1	1	N C	SWING PARKING 3 RELAY
RL-13	6	1	N C	PILOT PRESSURE CUT

RELAY				
RL-NO.	COIL SHEET No.	TERMINAL SHEET No.	TYPE	U S E
RL-14	6	6	N C	SWING HIGH LOW SPEED SELECT
RL-15	6	6	N O	SWING NEUTRAL BRAKE SELECT
RL-16	1	11	N O	PROPEL ALARM RELAY
RL-17	11	11	N O	PROPEL VOICE ALARM RELAY
RL-18	12	1	N C	HYD SELECT RELAY
RL-19	12	12	N O	HYD SELECT RELAY
RL-20	6	6	N O	HYD. OIL HEAT
RL-21	1	1	N O	E/G RESTART RELAY
RL-22	5			MC1 BYPASS RELAY
RL-22-1		5	N O N C	MC1 BYPASS RELAY
RL-22-2		5	N O N C	MC1 BYPASS RELAY
RL-22-3		5	N O N C	MC1 BYPASS RELAY
RL-22-4		5	N O N C	MC1 BYPASS RELAY
RL-22-5		5	N O N C	MC1 BYPASS RELAY
RL-22-6		5	N O N C	MC1 BYPASS RELAY
RL-22-7		5	N O N C	MC1 BYPASS RELAY
RL-22-8		5	N O N C	MC1 BYPASS RELAY
RL-22-9		5	N O N C	MC1 BYPASS RELAY
RL-22-10		5	N O N C	MC1 BYPASS RELAY
RL-23	1	1	N C	KEY RETURN RELAY

RELAY				
RL-NO.	COIL SHEET No.	TERMINAL SHEET No.	TYPE	U S E
RL-24	6	3	N C	LMI BYPASS RESET
RL-25	3			LMI BYPASS KEEP 1
RL-25-1		3	N O	LMI BYPASS KEEP 1
RL-25-2		3	N O	LMI BYPASS KEEP 2
RL-27	6	11	N O	SWING BUZZER
RL-28	3	5	N C	SPEED LIMIT RELEASE
RL-29	3	5	N O	SPEED LIMIT
RL-30	3	3	N O	OVER LOAD ALARM LAMP (GREEN)
RL-31	3	3	N O	OVER LOAD ALARM LAMP (YELLOW)
RL-32	3	3	N O	OVER LOAD ALARM LAMP (RED)
RL-36	6	3	N O	LMI ADJUSTMENT MODE SELECT
RL-37	6	6	N O	DPR RECYCLE RELAY
RL-38	6	6	N O	SWING FLASHER (L. H.) RELAY
RL-39	6	6	N O	SWING FLASHER (R. H.) RELAY
RL-40	6	6	N O	Qmax CUT RELAY
RL-41	6	6	N O	CLM RELAY
RL-42	6	6	N O	ESM RELAY
RL-43	6	6	N O	CLA RELAY
RL-44	6	6	N O	ESA RELAY
RL-45	6	6	N O	CLT RELAY

Ret

10. ELECTRIC SYSTEM

RELAY				
RL-NO.	COIL SHEET No.	TERMINAL SHEET No.	TYPE	U S E
RL-46	6	6	N.O.	EST RELAY
RL-47	6	6	N.O.	Fr. DRUM FREE SELECT RELAY
RL-48	6	6	N.O.	Re. DRUM FREE SELECT RELAY
RL-49	6	6	N.O.	3rd. DRUM FREE SELECT RELAY
RL-50	4			JIB OVER HOIST RELAY
RL-50-1		3	N.O.	JIB OVER HOIST RELAY
RL-50-2		3	N.O.	JIB OVER HOIST RELAY
RL-51	4	3	N.O.	NO. 2 LIMIT RELAY
RL-53	4	3	N.O.	BOOM OVER HOIST RELAY
RL-54	3	4	N.O.	SELF REMOVAL SELECT
RL-55	3	4	N.O.	ASSEMBLY DISASSEMBLY SELECT
RL-56	3	4	N.O.	MAST MODEL SELF REMOVAL SELECT
RL-57	3			JIB MODE SELECT
RL-57-1		4	N.O.	JIB MODE
RL-57-2		4	N.C.	JIB MODE
RL-58	3			SELF REMOVAL EXT. STOP
RL-58-1		12	N.O.	SELF REMOVAL EXT. STOP
RL-58-2		12	N.O.	SELF REMOVAL EXT. STOP
RL-60	3	7	N.O.	UNDULATION RAISE STOP
RL-61	3	7	N.O.	UNDULATION LOWER STOP

RELAY				
RL-NO.	COIL SHEET No.	TERMINAL SHEET No.	TYPE	U S E
RL-62	3	7	N.O.	MAIN RAISE STOP
RL-63	3	7	N.O.	MAIN LOWER STOP
RL-64	3	7	N.O.	AUX. RAISE STOP
RL-65	3	7	N.O.	AUX. LOWER STOP
RL-66	3	7	N.O.	3rd. RAISE STOP
RL-67	3	7	N.O.	3rd. LOWER STOP
RL-68	7			MC2 BYPASS RELAY
RL-68-1		7	N.O. N.C.	MC2 BYPASS RELAY
RL-68-2		7	N.O. N.C.	MC2 BYPASS RELAY
RL-68-3		7	N.O. N.C.	MC2 BYPASS RELAY
RL-68-4		7	N.O. N.C.	MC2 BYPASS RELAY
RL-68-5		7	N.O. N.C.	MC2 BYPASS RELAY
RL-68-6		7	N.O. N.C.	MC2 BYPASS RELAY
RL-68-7		7	N.O. N.C.	MC2 BYPASS RELAY
RL-68-8		7	N.O. N.C.	MC2 BYPASS RELAY
RL-68-9		7	N.O. N.C.	MC2 BYPASS RELAY
RL-68-10		7	N.O. N.C.	MC2 BYPASS RELAY
RL-68-11		7	N.O. N.C.	MC2 BYPASS RELAY
RL-68-12		7	N.O. N.C.	MC2 BYPASS RELAY
RL-68-13		7	N.O. N.C.	MC2 BYPASS RELAY

RELAY				
RL-NO.	COIL SHEET No.	TERMINAL SHEET No.	TYPE	U S E
RL-68-14		7	N.O. N.C.	MC2 BYPASS RELAY
RL-68-15		7	N.O. N.C.	MC2 BYPASS RELAY
RL-68-16		7	N.O. N.C.	MC2 BYPASS RELAY
RL-69	8	8	N.O.	Fr. DRUM INDEPENDENCE JUNCTION SELECT RELAY
RL-70	8	8	N.O.	Re. DRUM INDEPENDENCE JUNCTION SELECT RELAY
RL-71	8	8	N.O.	DPR LOAD MULTIPLIED RELAY
RL-80	9	9	N.O.	FUN MOTOR RELAY
RL-81	1	9	N.C.	A/C CUT RELAY
RL-82	6	11	N.O.	TW LATCH CYLINDER
RL-83	9	9	N.O.	AIS A/C CUT RELAY
RL-84	6	4	N.C.	SOL CUT RELAY 1
RL-85	6	1	N.C.	SOL CUT RELAY 2
RL-86	6	6	N.C.	SOL CUT RELAY 3
RL-87	3	3	N.O.	OVER LOAD ALARM BUZZER (RED)
RL-91	6	1	N.O.	SUB BATTERY RELAY 2
RL-93	1	1	N.C.	ACC CUT RELAY 1
RL-94	6	1	N.O.	ACC CUT RELAY 2

FUSE			
F-NO.	RATED	U S E	SHEET NO.
F-01	20	ELECTRIC POWER SOURCE	1
F-02	5	POWERSUPPLY-VOLTAGE WATCH RELAY	1
F-03	5	ITC and RADIO POWER SOURCE	1
F-04	5	ML BACK-UP	1
F-05	10	BYPASS SWITCH	3
F-06	5	RELEASE SWITCH	3
F-07	10	LMI CONTROL POWER	4
F-08	10	LMI OUTPUT POWER	4
F-09	10	MC1 CONTROL POWER	5
F-10	20	MC1 OUTPUT POWER	5
F-11	10	AUTO STOP	3
F-12	10	E/G CONDITION	1
F-13	5	ONE WAY/RADIO	10
F-14	20	WIPER	9
F-15	10	FUNCTION LOCK	1
F-16	10	REMOTE	12
F-17	5	MONITOR	11
F-18	15	A/C	9
F-19	10	A/C 2	9
F-20	10	FUN MOTOR	9

FUSE			
F-NO.	RATED	U S E	SHEET NO.
F-21	5	GENERATION OF ELECTRICITY SENSOR	1
F-24	15	ECU (+BF)	2
F-25	20	ECU (+B)	2
F-26	15	ECU	2
F-27	20	OIL COOLER FUN MOTER 1	8
F-28	30	OIL COOLER FUN MOTER 2	8
F-29	10	SWING FLASHER/VOICE ARARM	11
F-30	5	STARTER	1
F-31	10	MC2 CONTROL POWER	7
F-32	20	MC2 OUTPUT POWER	7
F-33	5	MC2 EARTH OUTPUT POWER	8
F-34	5	OVERHOIST L/S	4
F-35	10	FUEL PUMP/CIGARETTE LIGHTER	9
F-36	10	MC1 EARTH OUTPUT POWER 1	6
F-37	10	MC1 EARTH OUTPUT POWER 2	6
F-38	5	NEUTRAL FREE	6
F-39	10	LIGHT	11
F-40	10	SPARE	11

SOLENOID VALVE		
SOL-NO.	U S E	SHEET NO.
SOL-3	FUNCTION LOCK	1
SOL-4	PROPEL SPEED SELECT	1
SOL-5	SWING PARKING ON FOR RELEASE OFF FOR PARKING	1
SOL-10	Fr. DRUM C/V	8
SOL-11	Re. DRUM C/V	8
SOL-12	3rd. DRUM C/V	8
SOL-15	Fr. DRUM MOTOR BOOST	8
SOL-16	Re. DRUM MOTOR BOOST	8
SOL-17	3rd. DRUM MOTOR BOOST	8
SOL-18	3rd. RAISE STOP	3
SOL-19	Fr. DRUM CLUTCH ESM	6
SOL-20	Re. DRUM CLUTCH ESA	6
SOL-21	3rd. DRUM CLUTCH EST	6
SOL-22	Fr. DRUM CLUTCH CLM	6
SOL-23	Re. DRUM CLUTCH CLA	6
SOL-24	3rd. DRUM CLUTCH CLT	6
SOL-26	GANTRY UP	12
SOL-27	GANTRY DOWN	12
SOL-35	BOOM RAISE STOP	3

SOLENOID VALVE		
SOL-NO.	U S E	SHEET NO.
SOL-36	BOOM LOWER STOP	3
SOL-37	MAIN RAISE STOP	3
SOL-38	AUX. RAISE STOP	3
SOL-42	SWING HIGH LOW SPEED SELECT	6
SOL-44	TRANSLIFTER SELECT	12
SOL-45	HYD. SELECT (FOOT PIN/REEVING)	1
SOL-47	HYD. OIL HEAT	6
SOL-48	SWING NEUTRAL SELECT	6
SOL-49	SWING NEUTRAL SELECT	6
SOL-69	JIB UNDULATION DRUM LOCK (ON FOR UNLOCK)	1
SOL-77	UNDULATION PEDAL	1
SOL-80	VERTICAL CYLINDER EXT. (Fr. R. H.)	12
SOL-81	VERTICAL CYLINDER EXT. (Re. R. H.)	12
SOL-82	CRAWLER PIN CYLINDER (Re. EXT)	12
SOL-83	CRAWLER PIN CYLINDER (Fr. EXT)	12
SOL-84	VERTICAL CYLINDER EXT. (Re. L. H.)	12
SOL-85	VERTICAL CYLINDER EXT. (Fr. L. H.)	12
SOL-86	VERTICAL CYLINDER RET. (Fr. R. H.)	12
SOL-87	VERTICAL CYLINDER RET. (Re. R. H.)	12
SOL-88	CRAWLER PIN CYLINDER (Re. RET)	12

Refer

10. ELECTRIC SYSTEM

SOLENOID VALVE		
SOL-NO.	U S E	SHEET NO.
SOL-89	CRAWLER PIN CYLINDER (Fr. RET)	12
SOL-90	VERTICAL CYLINDER RET. (Re. L. H.)	12
SOL-91	VERTICAL CYLINDER RET. (Fr. L. H.)	12
SOL-95	LEFT CYLINDER RET.	12
SOL-96	LEFT CYLINDER EXT.	12
SOL-97	RIGHT CYLINDER RET.	12
SOL-98	RIGHT CYLINDER EXT.	12
SOL-101	Fr. DRUM INDEPENDENCE JUNCTION SELECT	8
SOL-102	Re. DRUM INDEPENDENCE JUNCTION SELECT	8
SOL-104	Qmax CUT	6
SOL-105	CRAWLER EXT. RET. (LEFT/RIGHT)	1
SOL-106	CRAWLER EXT. RET. (LEFT/RIGHT)	1
SOL-111	DPR LOAD MULTIPLIED	8

SOLENOID VALVE		
PSOL-NO.	U S E	SHEET NO.
PSOL-1	MAIN PUMP 1	5
PSOL-2	BOOM PUMP	5
PSOL-6	MAIN PUMP 2	5
PSOL-40	Fr. DRUM TURN GRIP	6
PSOL-41	Re. DRUM TURN GRIP	6
PSOL-50	MAIN PUMP CONTROL	5
PSOL-51	SWING REACTION	5
PSOL-52	BOOM RAISE CONTROL	7
PSOL-53	BOOM LOWER CONTROL	7
PSOL-54	Fr. DRUM HOIST CONTROL	7
PSOL-55	Fr. DRUM LOWER CONTROL	7
PSOL-56	Re. DRUM HOIST CONTROL	7
PSOL-57	Re. DRUM LOWER CONTROL	7
PSOL-58	3rd. DRUM HOIST CONTROL	7
PSOL-59	3rd. DRUM LOWER CONTROL	7
PSOL-62	TAGLINE	5
PSOL-65	Fr. DRUM CONTROL PROPORTIONAL VALVE	7
PSOL-66	Re. DRUM CONTROL PROPORTIONAL VALVE	7
PSOL-67	3rd. DRUM CONTROL PROPORTIONAL VALVE	7
PSOL-70	BOOM PUMP CONTROL	5

SOLENOID VALVE		
PSOL-NO.	U S E	SHEET NO.
PSOL-72	SWING CONSTANT SPEED	5
PSOL-103	MOTER CHP CONTROL SYSTEM	7
PSOL-107	Fr. DRUM MIDDLE DITENT	5
PSOL-108	Re. DRUM MIDDLE DITENT	5
PSOL-109	R. H. SWING STOP	5
PSOL-110	L. H. SWING STOP	5

SWITCH		
SW-NO.	U S E	SHEET NO.
SW-1	E/G KEY	1
SW-8	PROPEL SPEED SELECT	1
SW-9	INCHING SPEED SELECT	1
SW-11	SWING PARKING	1
SW-12	GANTRY CONTROL	12
SW-13	HOOK OVERHOIST RELEASE	3
SW-14	BOOM OVERHOIST RELEASE	3
SW-15	LMI RELEASE	3
SW-16	MASTER KEY	3
SW-17	WIPER (FRONT)	9
SW-18	WIPER (ROOF)	9
SW-19	WASHER SWITCH	9
SW-20	ROOM LIGHT	10
SW-21	HED LIGHT SWITCH	10
SW-22	WORK LIGHT (REAR)	11
SW-23	SWING FLASHER	11
SW-24	HORN SWITCH	10
SW-25	CRAWLER EXPANSION AND CONTRACTION	1
SW-26	PROPEL ALARM VOICE	11
SW-27	MULTI VOICE	11

SWITCH		
SW-NO.	U S E	SHEET NO.
SW-33	DRUM TURN DETECT GRIP	11
SW-35	AUTO STOP CHECK	3
SW-36	POSTURE SELECT	3
SW-37	LM1 BYPASS MAIN	3
SW-38	MC1 BYPASS	5
SW-39	MC2 BYPASS	7
SW-45	FREE FALL PERMIT	1
SW-50	SMULTANEOUS CONTROL POSSIBLE	3
SW-51	DRUM SELECT	3
SW-53	Fr. DRUM FREE FALL SELECT	6
SW-54	Re. DRUM FREE FALL SELECT	6
SW-55	3rd. DRUM FREE FALL SELECT	6
SW-56	Fr. DRUM FREE FALL SPEED	6
SW-57	Re. DRUM FREE FALL SPEED	6
SW-58	3rd. DRUM FREE FALL SPEED	6
SW-64	UNDULATION PEDAL SELECT	1
SW-65	HYDRAULIC SELECT	1
SW-71	E/G EMERGENCY STOP SWITCH	2
SW-72	AUXILIARY ACCELSE SW	2
SW-74	FAN	10

SWITCH		
SW-NO.	U S E	SHEET NO.
SW-75	LAUCH LOCK OPERATION	11
SW-77	WORK LIGHT (DRUM)	11
SW-79	JIB UNDULATION DRUM LOCK	1
SW-81	AIS MODE SELECT	6
SW-82	Re. DRUM G WINCHI	1
SW-83	G ENGINE	6
SW-84	Fr. DRUM G WINCHI	1
SW-85	SWITCH	10
SW-86	G WINCHI MODE SELECT	6

LIMIT SWITCH		
LSW-NO.	U S E	SHEET NO.
LSW-1	FUNCTION LOCK	1
LSW-2	MAIN HOOK OVERHOIST	4
LSW-3	AUX. HOOK OVERHOIST	4
LSW-4	HOOK OVERHOIST (AUX)	4
LSW-5	JIB OVER HOIST	4
LSW-6	HOOK OVERHOIST (JIB)	4
LSW-7	BOOM OVER HOIST	4
LSW-9	BOOM OVERHOIST (No. 1)	4
LSW-12	BOOM OVERHOIST (No. 2)	4
LSW-14	ROOM LIGHT DOOR	10
LSW-15	ENG. OIL FILTER ALARM	6
LSW-20	BRAKE COOLING OIL TEMP. (Fr. DRUM)	6
LSW-21	BRAKE COOLING OIL TEMP. (Re. DRUM)	6
LSW-22	LINE FILTER ALARM	6
LSW-24	MAST CYLINDER	4
LSW-26	Fr. DRUM OVER PAY OUT	4
LSW-27	Re. DRUM OVER PAY OUT	4
LSW-28	SPARE OVER PAY OUT	4
LSW-30	HYD. OIL TEMP.	1
LSW-35	AIR CLEANER ALARM	6

LIMIT SWITCH		
LSW-NO.	U S E	SHEET NO.
LSW-38	TOWER JIB BENDS LOSS	4
LSW-39	LATCH REIATIONS LIMIT SWITCH	4
LSW-40	LATSH THE EDGE LIMIT SWITCH	4
LSW-41	GANTRY STAND UP DETECT	4

Refer

10. ELECTRIC SYSTEM

PRESSURE SWITCH			
PSW-NO.	TYPE	U S E	SHEET NO.
PSW-1	N.O.	Fr. DRUM FOOT BRAKE PRESSURE SW	6
PSW-2	N.O.	Re. DRUM FOOT BRAKE PRESSURE SW	6
PSW-3	N.O.	3rd. DRUM FOOT BRAKE PRESSURE SW	6
PSW-7	N.O.	PROPEL CONTROL DETECT SW. (R. H.)	1
PSW-8	N.C.	ENGINE OIL PRESSURE SW	6
PSW-9	N.O.	A/C PRESSURE SWITCH	9
PSW-10	N.O.	PROPEL CONTROL DETECT SW. (L. H.)	1

PRESSURE SENSOR		
PT-NO.	U S E	SHEET NO.
PT-1	SWING PUMP PRESSURE	5
PT-3	Fr. DRUM HOISTING PRESSURE SENSOR	7
PT-4	Fr. DRUM LOWERING PRESSURE SENSOR	7
PT-5	Re. DRUM HOISTING PRESSURE SENSOR	7
PT-6	Re. DRUM LOWERING PRESSURE SENSOR	7
PT-7	3rd. DRUM HOISTING PRESSURE SENSOR	7
PT-8	3rd. DRUM LOWERING PRESSURE SENSOR	7
PT-9	Fr. DRUM CLUTCH PRESSURE	5
PT-10	Re. DRUM CLUTCH PRESSURE	5
PT-11	3rd. DRUM CLUTCH PRESSURE	5
PT-12	BOOM RAISEING PRESSURE SENSOR	7
PT-13	BOOM LOWERING PRESSURE SENSOR	7
PT-14	Re. DRUM CONTROL ROPORTIONAL PRESSURE SENSOR	7
PT-15	3rd. DRUM CONTROL ROPORTIONAL PRESSURE SENSOR	7
PT-16	CONTROL PRIMARY PRESSURE	5
PT-17	Fr. DRUM INDEPENDENCE JUNCTION SELECT PRESSURE SENSOR	7
PT-18	Re. DRUM INDEPENDENCE JUNCTION SELECT PRESSURE SENSOR	7
PT-19	MAIN AUX. CHP START PRESSURE SENSOR	7

PRESSURE SENSOR		
PT-NO.	U S E	SHEET NO.
PT-20	Fr. DRUM CONTROL ROPORTIONAL PRESSURE SENSOR	7
PT-21	Qmax CUT FB	5
PT-22	SWING CONTROL (R. H.)	5
PT-23	SWING CONTROL (L. H.)	5
PT-24	POWER SHIFT PRESSUER	5

PIROT LAMP		
PL-NO.	U S E	SHEET NO.
PL-7	CHECK ENG. LAMP (RED)	2

10.1.2 CONNECTOR LAYOUT

Wire color / Parts No. list

Basic single color

Color Sign	Color Name
B	Black
W	White
R	Red
G	Green
Y	Yellow
Br	Brown
L	bLue
Lg	Light green
Gr	Gray
O	Orange
Sb	Skyblue
P	Pink
V	Violet
F r e e	Free

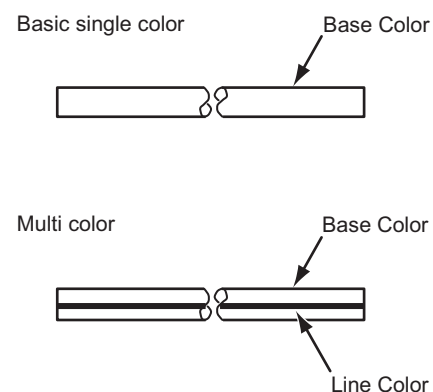

Multi color

Color Sign	Base Color	Line Color
BW	Black	White
BR	Black	Red
BG	Black	Green
BY	Black	Yellow
BL	Black	bLue
WB	White	Black
WR	White	Red
WG	White	Green
WY	White	Yellow
WL	White	bLue
WO	White	Orange
RB	Red	Black
RW	Red	White
RG	Red	Green
RY	Red	Yellow
RL	Red	bLue
GB	Green	Black
GW	Green	White
GR	Green	Red
GY	Green	Yellow
GL	Green	bLue
GO	Green	Orange
YB	Yellow	Black
YW	Yellow	White
YR	Yellow	Red
YG	Yellow	Green
YL	Yellow	bLue
YV	Yellow	Violet
BrB	Brown	Black
BrW	Brown	White
BrR	Brown	Red

Color Sign	Base Color	Line Color
BrG	Brown	Green
BrY	Brown	Yellow
BrL	Brown	bLue
LB	bLue	Black
LW	bLue	White
LR	bLue	Red
LG	bLue	Green
LY	bLue	Yellow
LO	bLue	Orange
LgB	Light green	Black
LgW	Light green	White
LgR	Light green	Red
LgY	Light green	Yellow
LgL	Light green	bLue
GrB	Gray	Black
GrW	Gray	White
G r R	Gray	Red
G r L	Gray	bLue
OB	Orange	Black
OY	Orange	Yellow
OL	Orange	bLue
OW	Orange	White
S b B	Skyblue	Black
S b R	Skyblue	Red
S b L	Skyblue	bLue
PB	Pink	Black
PW	Pink	White
PR	Pink	Red
PG	Pink	Green
PL	Pink	bLue
VR	Violet	Red

No.	HARNESS NAME
1	FLOOR PLATE
	FLOOR A
	FLOOR B
	OUT INDICATING LIGHT RELAY JUNCTION HARNESS
2	LOWER
	LOWER HARNESS
	TRANS LIFTER REMOTE CONTROLLER CABLE (OPTION)
3	LEFT DECK
	LEFT DECK HARNESS
	RELAY HARNESS
4	RIGHT DECK
	RIGHT DECK HARNESS
	POWER SUPPLY HARNESS
	STARTER (TERMINAL B) TO BATTERY RELAY
	STARTER (TERMINAL C) TO SAFETY RELAY
	GLOW RELAY TO ENGINE SUB HARNESS
5	RIGHT DECK (GUARD)
	GUARD HARNESS A
	GUARD HARNESS B
6	GUARD HARNESS C
	SWING FRAME
	SWING FRAME HARNESS
7	ATT. JUNCTION HARNESS
	CAB
8	CAB HARNESS
	ENGINE
9	STARTER MOTOR TO ENGINE GROUND
	STARTER MOTOR TARMINAL B ALTERNATOR B TARMINAL
10	MONITOR
	MONITOR HARNESS
11	COUNTER WEIGHT SELF REMOVAL (OPTION)
	COUNTER WEIGHT SELF REMOVAL
12	OVER LOAD PREVENT (M. MACHINERY)
13	TRANS LIFTER (OPTION)
13	BLANK

10. ELECTRIC SYSTEM

No.	HARNESS NAME
14	HYDRAULIC OIL HEAT
	HYDRAULIC OIL HEAT
15	BOOM BASE (INSERT INCLUDED)
	BOOM BASE (INSERT INCLUDED)
16	BOOM TIP
17	BLANK
18	FIXED JIB
	FIXED JIB
19	CAMERA CONTROLLER
	CAMERA CONTROLLER
	CAMERA CONTROLLER
20	IT CONTROLLER INSTALLATION



1.ELECTRICAL PART OF FLOOR PLATE

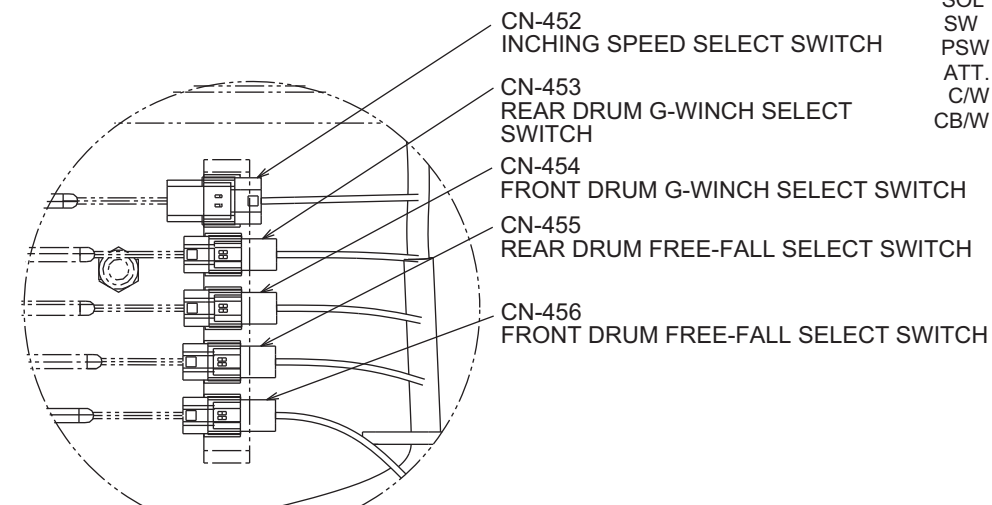
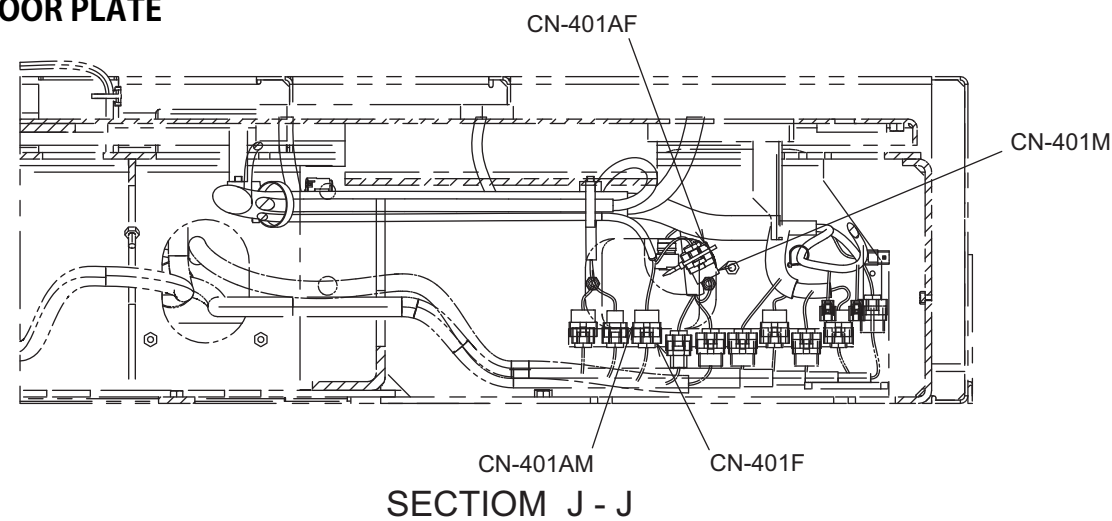

SOL : SOLENOID VALVE
 SW : SWITCH
 PSW : PRESSURE SWITCH
 ATT. : ATTACHMENT
 C/W : COUNTER WEIGHT
 CBW : CARBODY WEIGHT

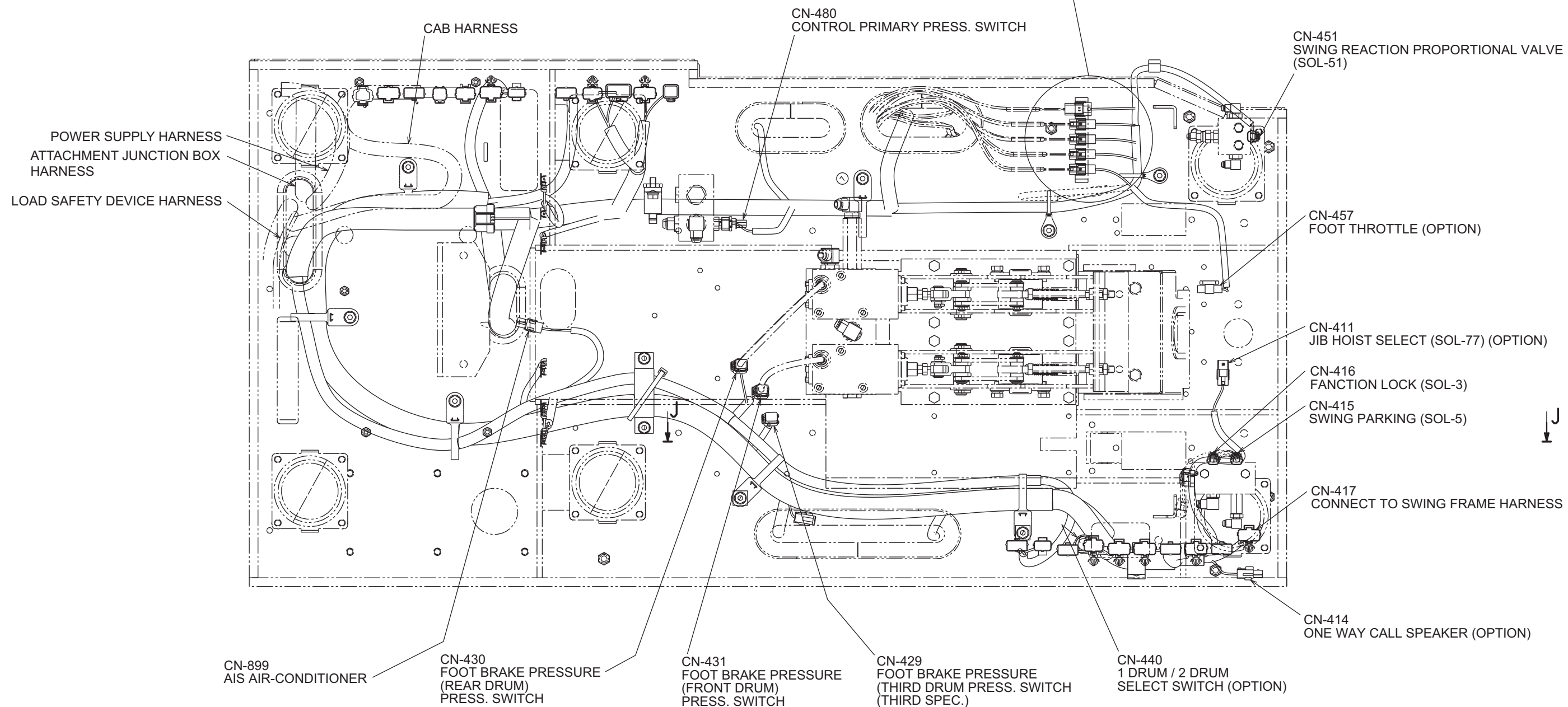

VIEW FROM THE FLOOR PLATE UNDER

10. ELECTRIC SYSTEM

SOL : SOLENOID VALVE
 SW : SWITCH
 PSW : PRESSURE SWITCH
 ATT. : ATTACHMENT
 C/W : COUNTER WEIGHT
 CB/W : CARBODY WEIGHT

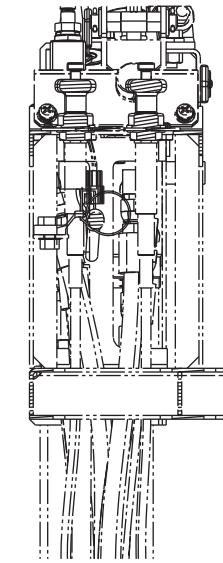
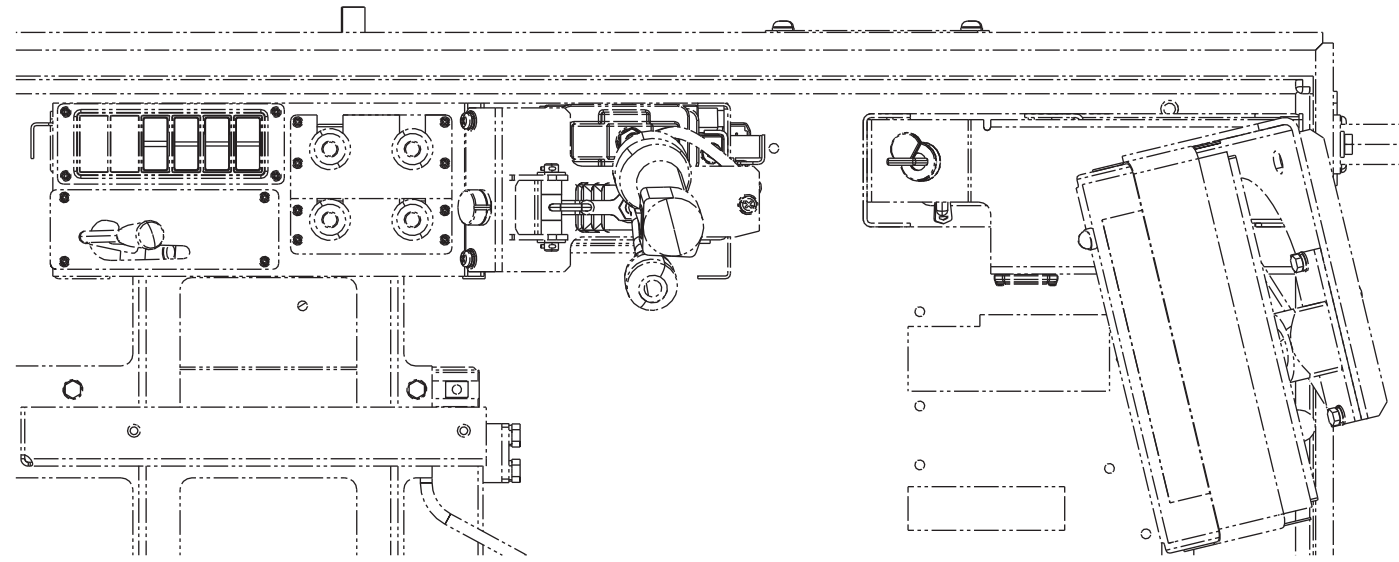

VIEW FROM "C"

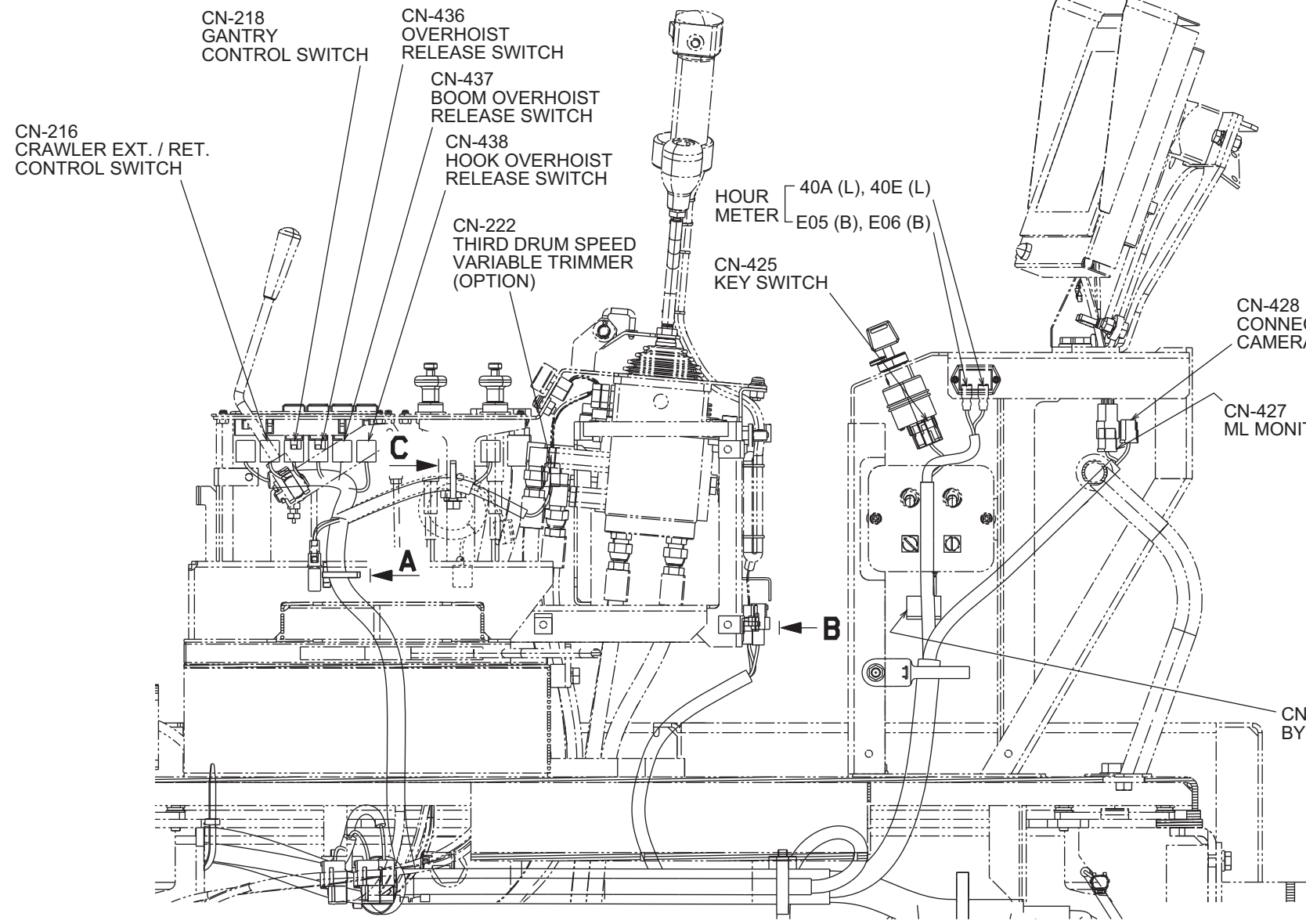

DETAIL OF LEFT STAND

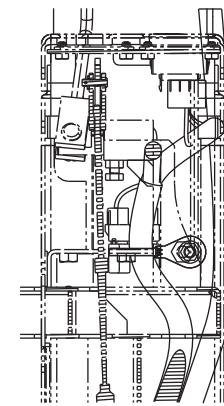

VIEW FROM "A"

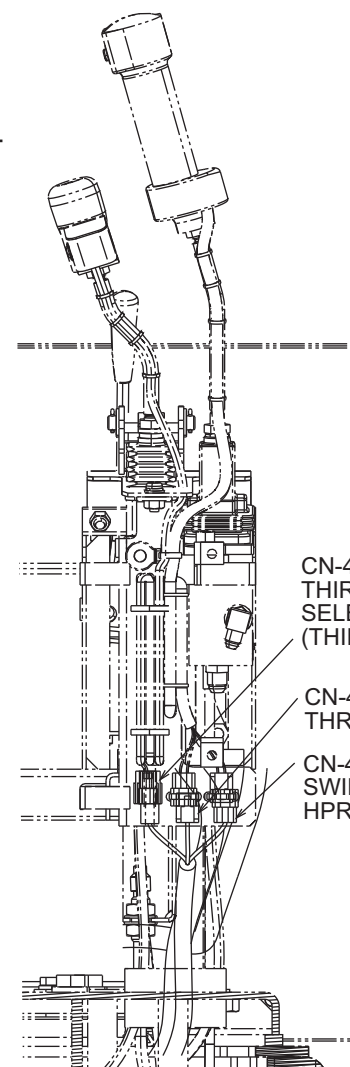

VIEW FROM "B"

SOL : SOLENOID VALVE
 SW : SWITCH
 PSW : PRESSURE SWITCH
 ATT. : ATTACHMENT
 C/W : COUNTER WEIGHT
 CB/W : CARBODY WEIGHT

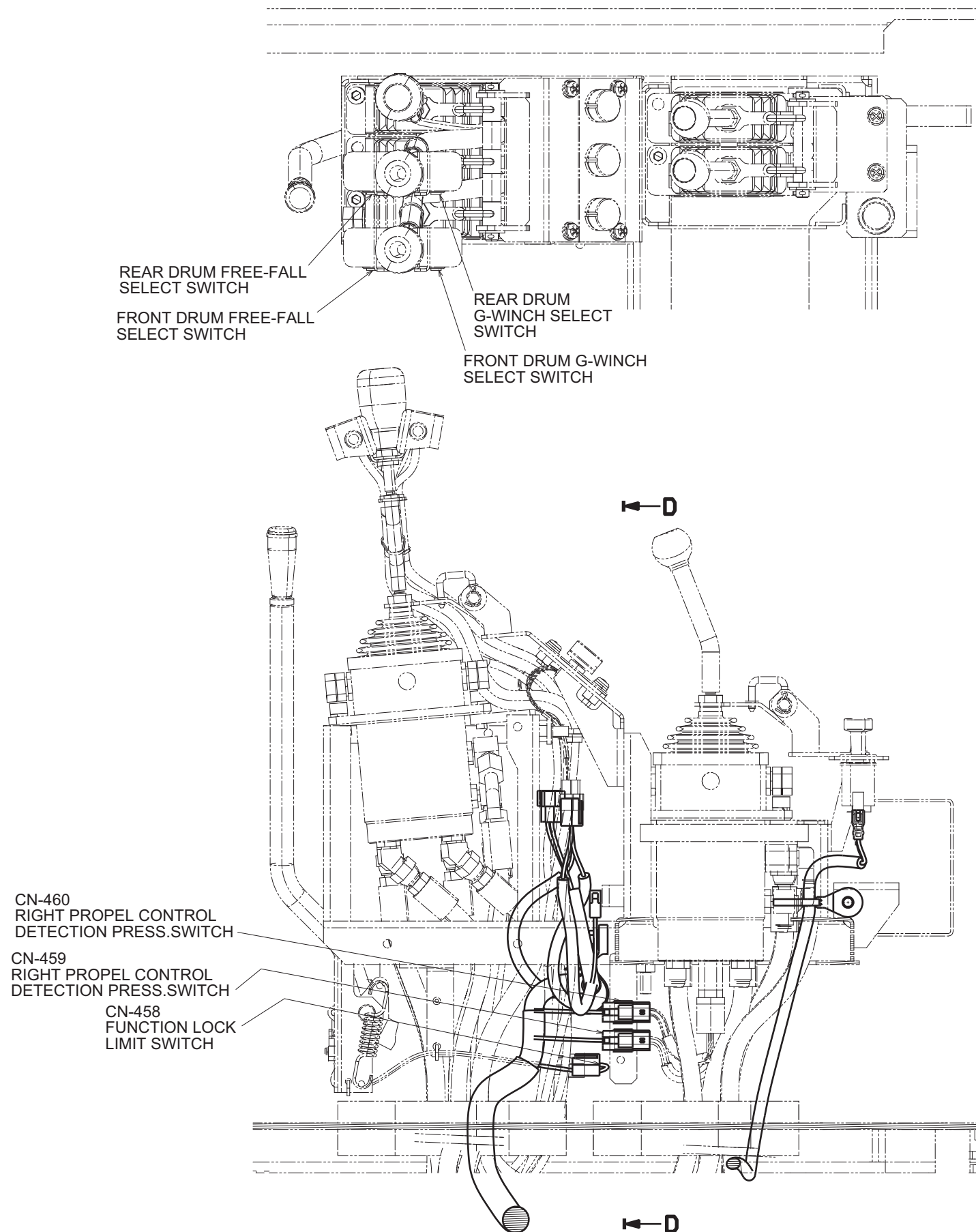

DETAIL OF RIGHT SIDE STAND

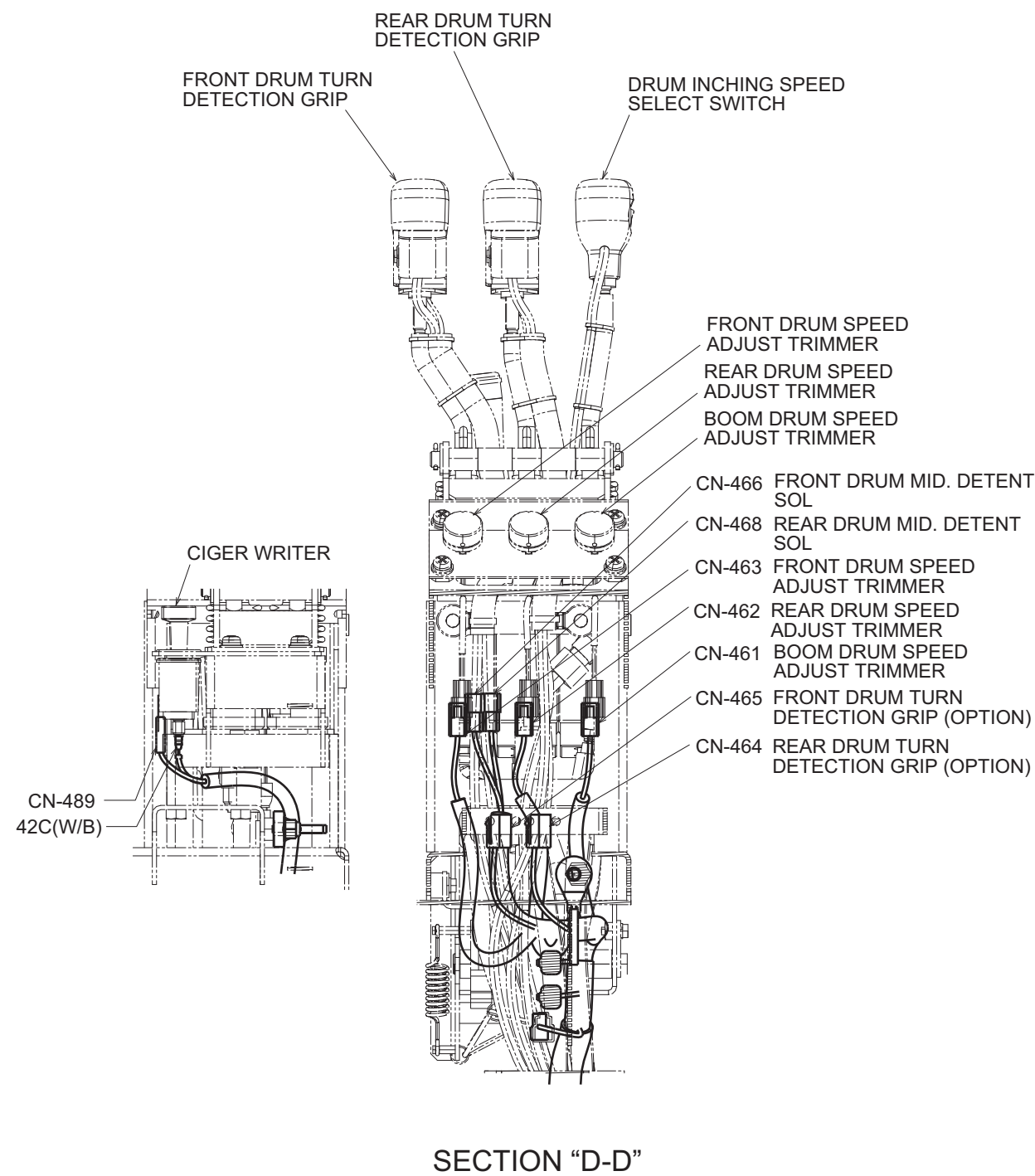

SOL : SOLENOID VALVE
 SW : SWITCH
 PSW : PRESSURE SWITCH
 ATT. : ATTACHMENT
 CW : COUNTER WEIGHT
 CB/W : CARBODY WEIGHT

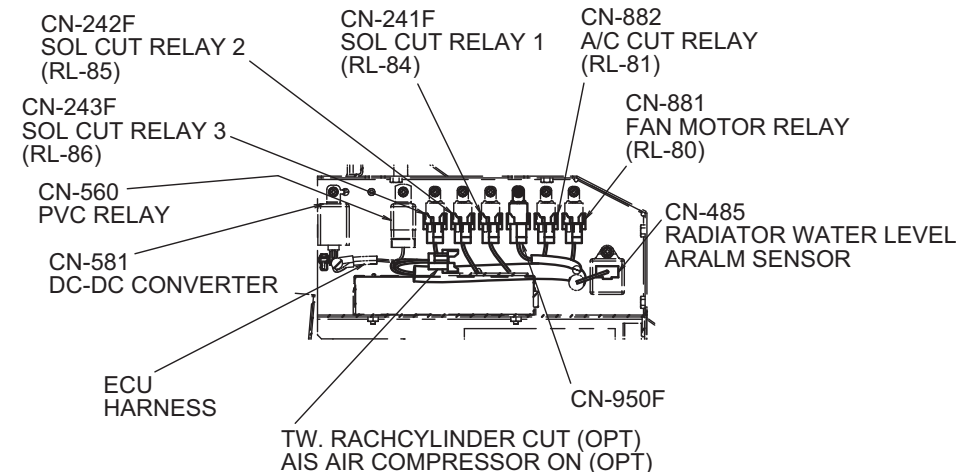
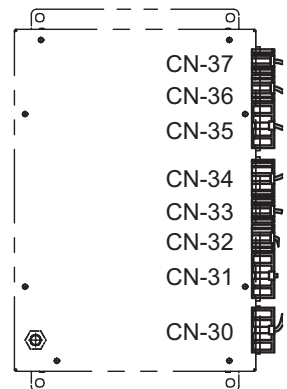
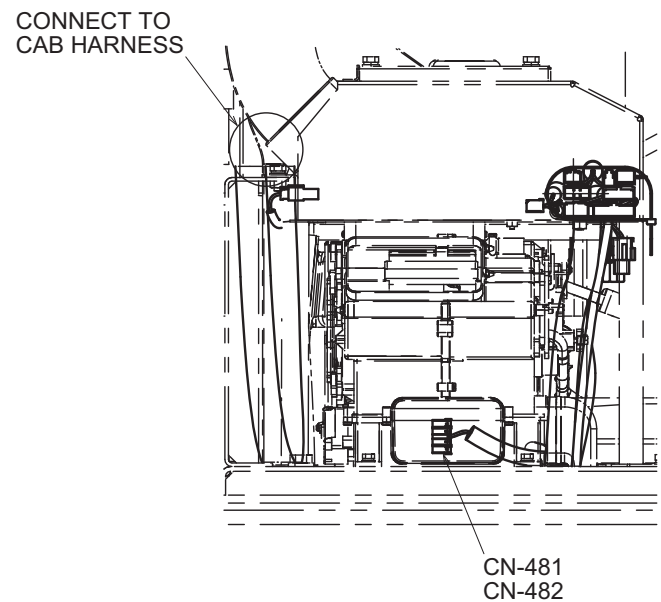
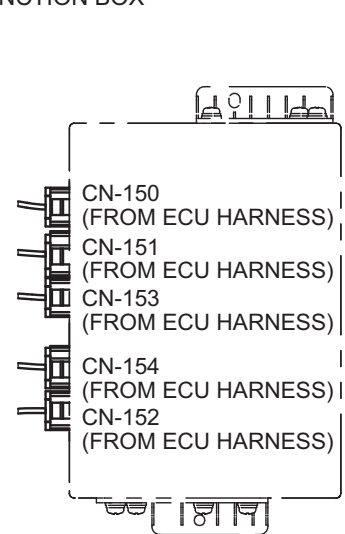
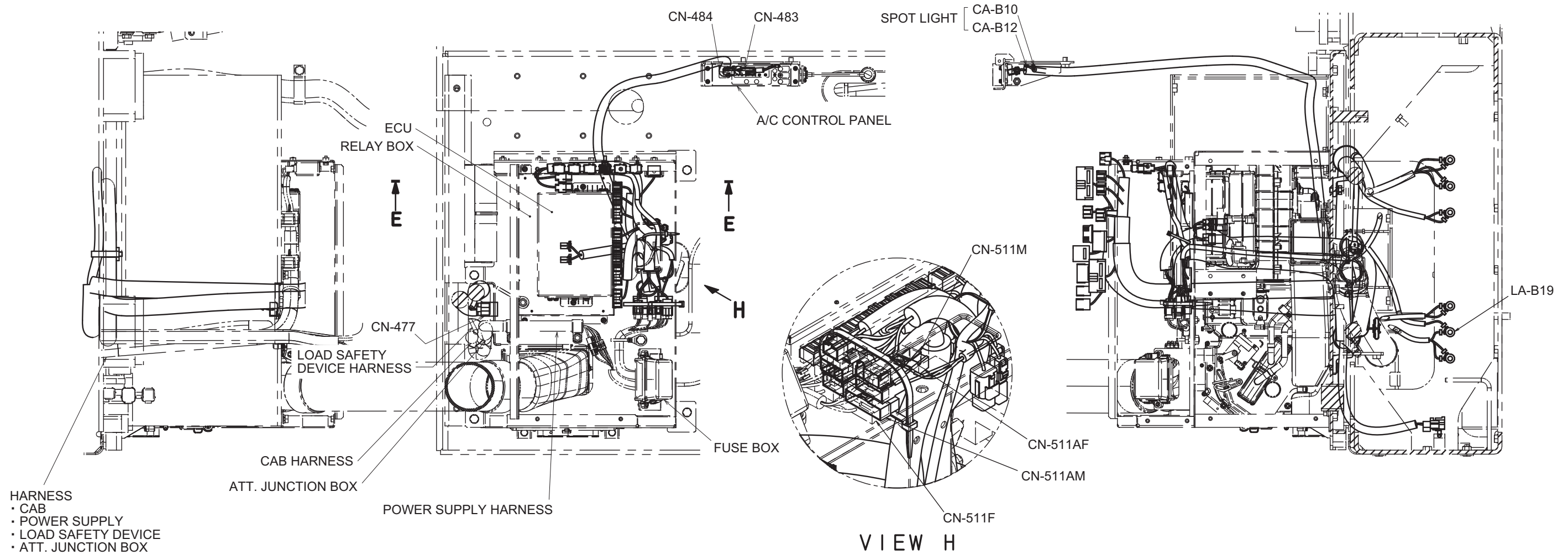

OUT INDICATING LIGHT RELAY JUNCTION HARNESS

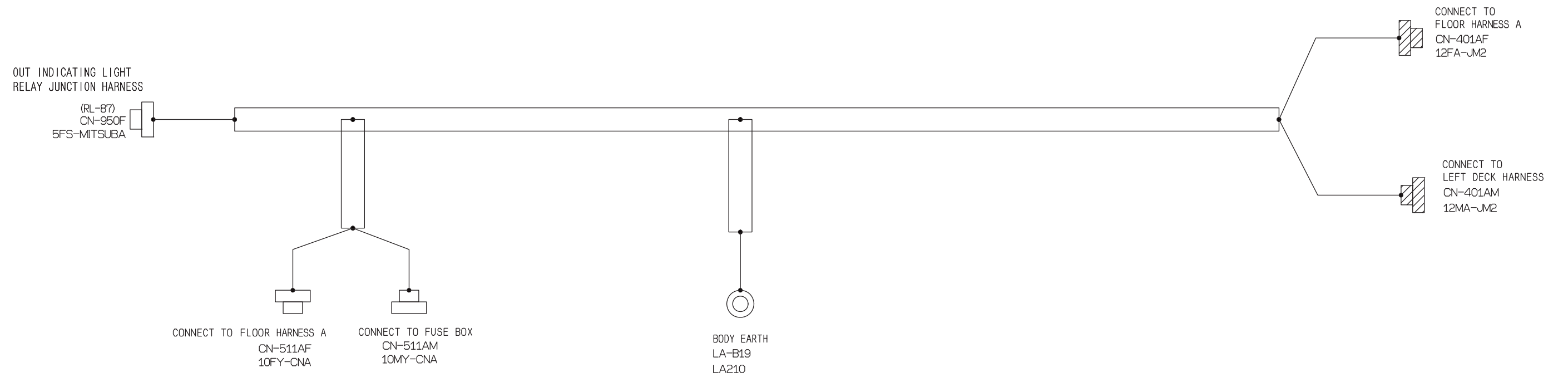

10. ELECTRIC SYSTEM

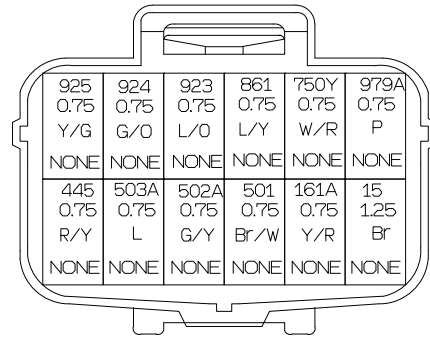

CN-401AF
12FA-JM2

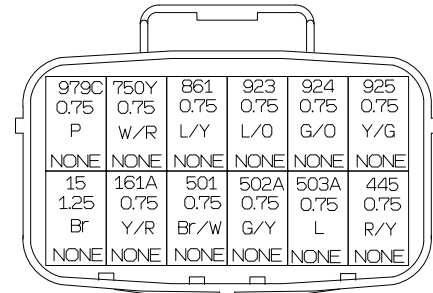

CN-401AM
12MA-JM2

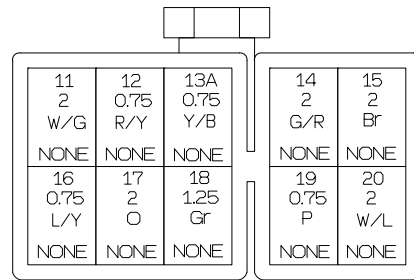

CN-511AF
10FY-CNA

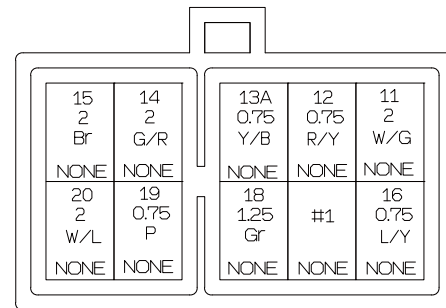

CN-511AM
10MY-CNA
#1 17 1.25 O +17A 0.75 O

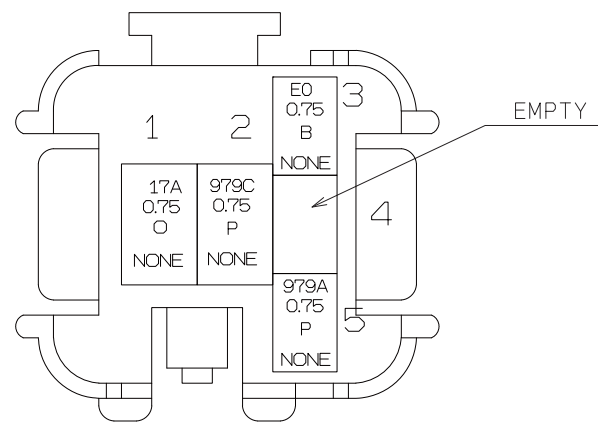

CN-950F
5FS-MITSUBA

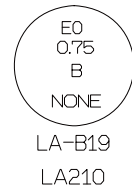

WIRE No. AND WIRE COLOR LIST

No.	COLOR	TYPE	SIZE	FROM	2-WIRE CLAMP No.	CONNECTION	2-WIRE CLAMP No.	TO
11	W/G	AVS	2	CN-511AM				CN-511AF
12	R/Y	AVSS	0.75	CN-511AM				CN-511AF
13A	Y/B	AVSS	0.75	CN-511AM				CN-511AF
14	G/R	AVS	2	CN-511AM				CN-511AF
15	Br	AVS	2	CN-511AM				CN-511AF
15	Br	AVSS	1.25	CN-401AF				CN-401AM
16	L/Y	AVSS	0.75	CN-511AM				CN-511AF
17	O	AVS	1.25	CN-511AM				CN-511AF
17A	O	AVSS	0.75	CN-511AM				CN-950F
18	Gr	AVS	1.25	CN-511AM				CN-511AF
19	P	AVSS	0.75	CN-511AM				CN-511AF
20	W/L	AVS	2	CN-511AM				CN-511AF
161A	Y/R	AVSS	0.75	CN-401AM				CN-401AF
445	R/Y	AVSS	0.75	CN-401AM				CN-401AF
501	Br/W	AVSS	0.75	CN-401AM				CN-401AF
502A	G/Y	AVSS	0.75	CN-401AM				CN-401AF
503A	L	AVSS	0.75	CN-401AM				CN-401AF
705Y	W/R	AVSS	0.75	CN-401AM				CN-401AF
861	L/Y	AVSS	0.75	CN-401AM				CN-401AF
923	L/O	AVSS	0.75	CN-401AM				CN-401AF
924	G/O	AVSS	0.75	CN-401AM				CN-401AF
925	Y/G	AVSS	0.75	CN-401AM				CN-401AF
979A	P	AVSS	0.75	CN-401AF				CN-950F
979C	P	AVSS	0.75	CN-401AM				CN-950F
E0	B	AVSS	0.75	CN-950F				LA-B19

FLOOR HARNESS A

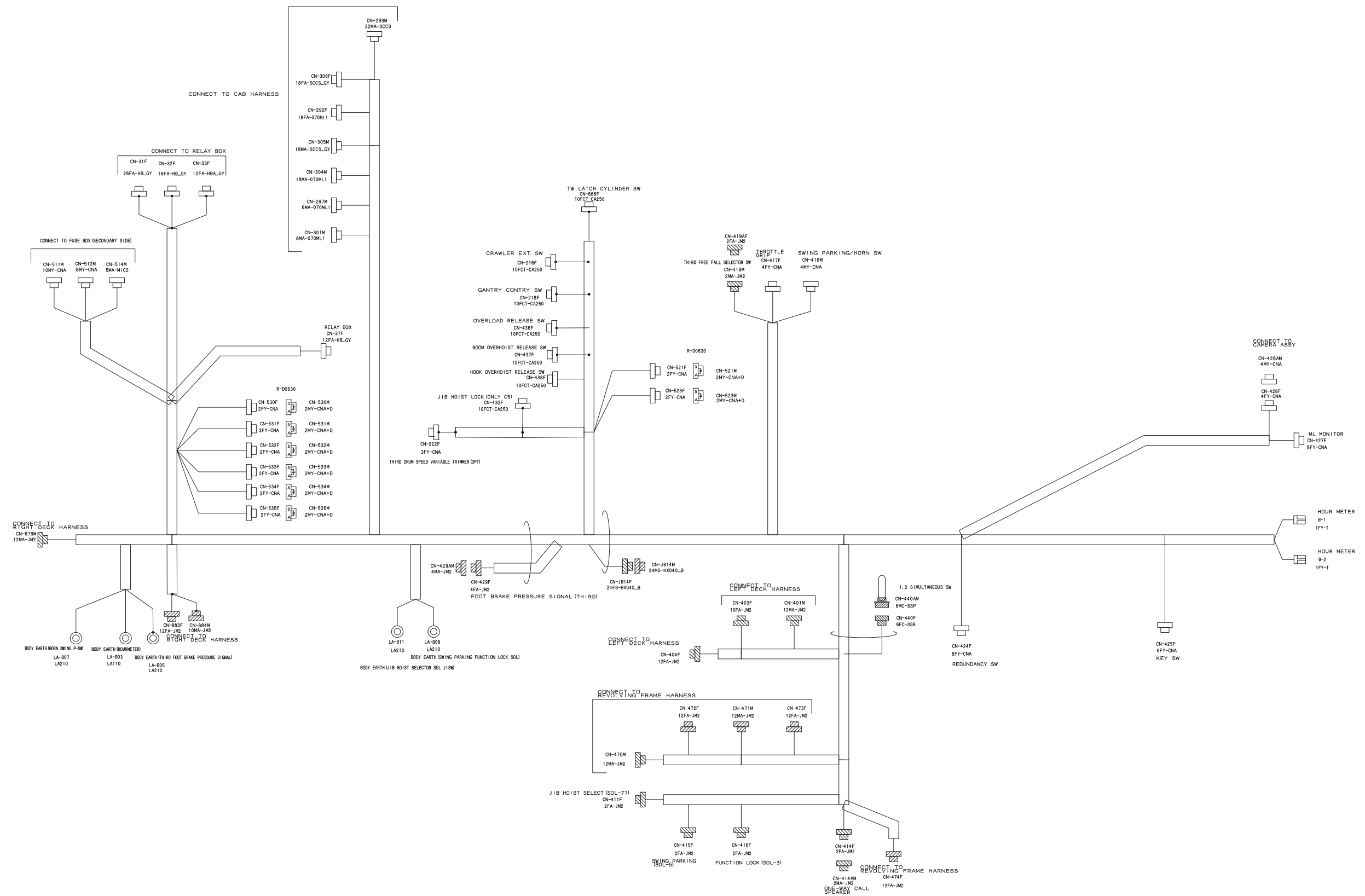

10. ELECTRIC SYSTEM

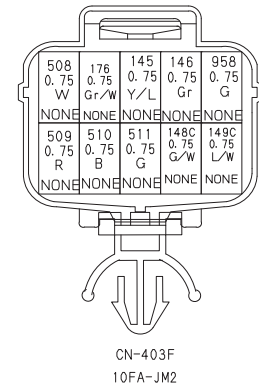
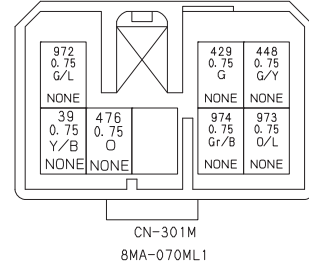
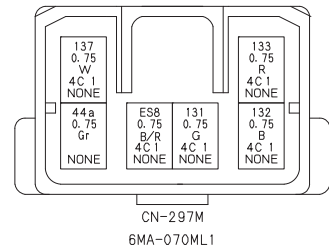
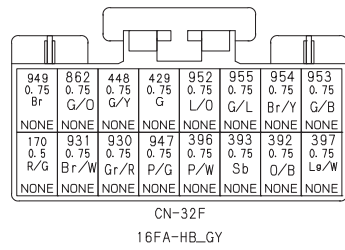
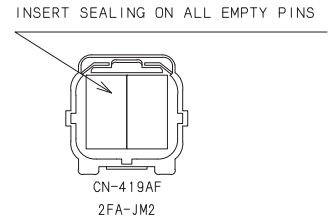
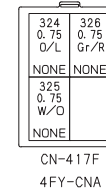
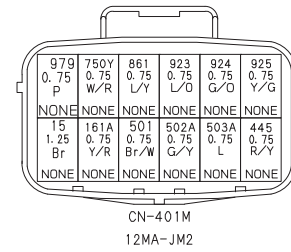
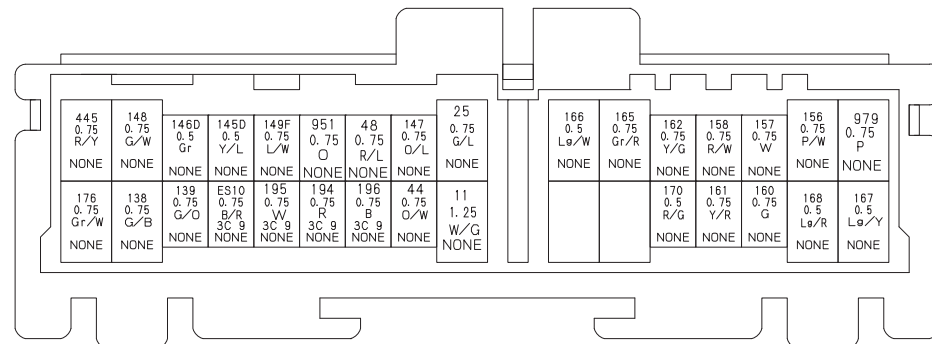
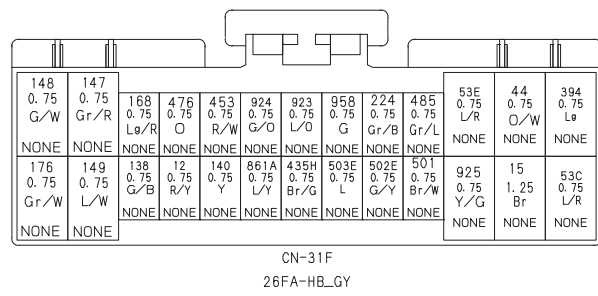

2-WIRE CLAMP

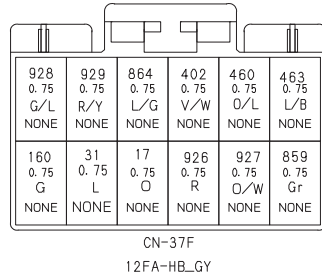
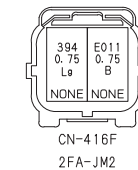
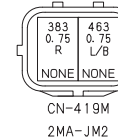
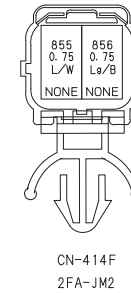
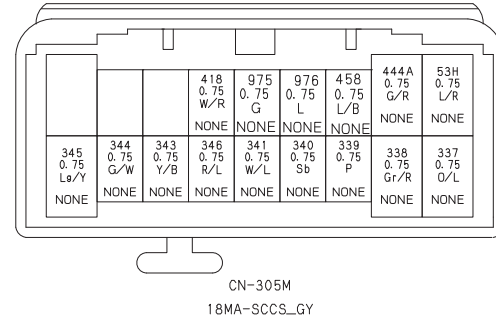
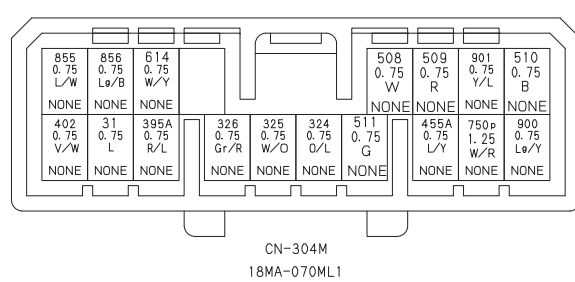
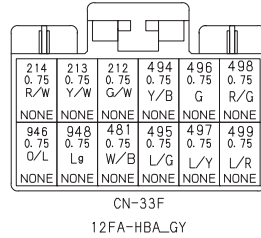
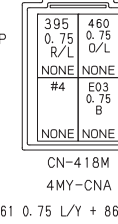

2-WIRE CLAMP

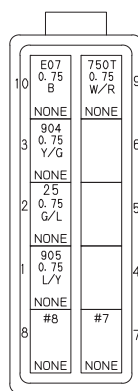

#7 750S 0.75 W/R + 750T 0.75 W/R
#8 E07 0.75 B + E08 0.75 B

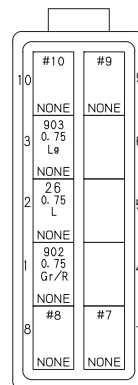

#7 750t 0.75 W/R + 750u 0.75 W/R
#8 E018 0.75 B + E019 0.75 B
#9 750u 0.75 W/R + 750v 0.75 W/R
#10 E018 0.75 B + E07 0.75 B

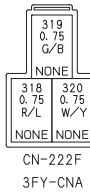
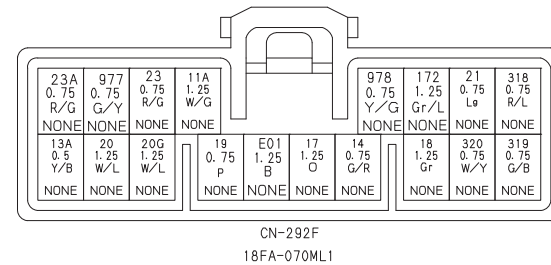
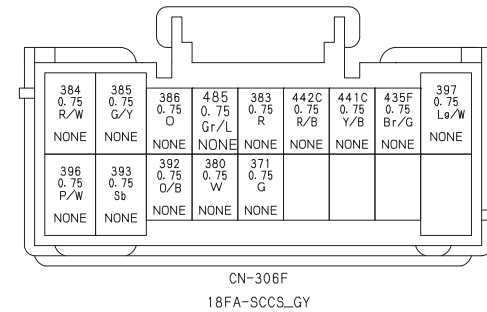

INSERT SEALING ON ALL EMPTY PINS

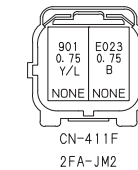
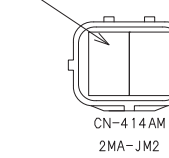

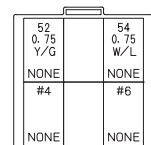
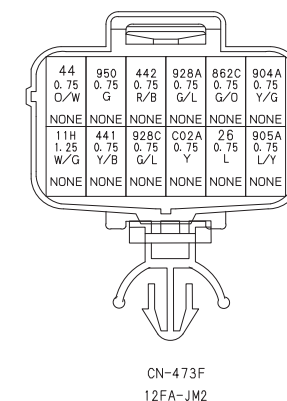
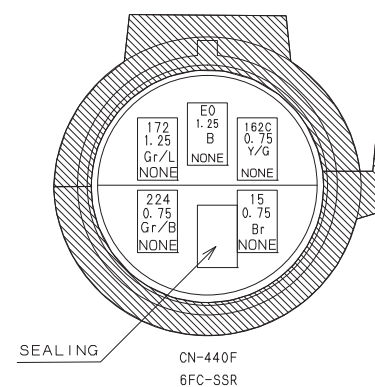
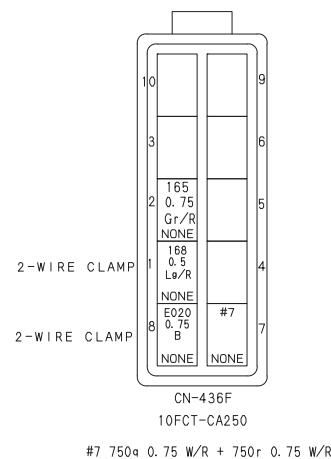
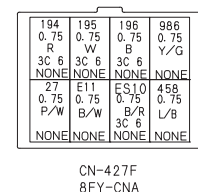
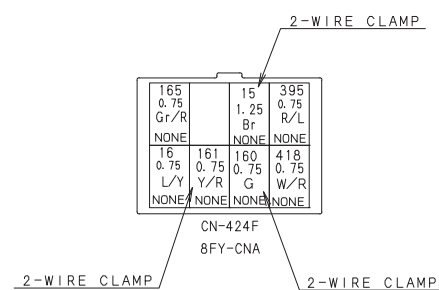

#4 53 0.75 L/R + 53A 0.75 L/R
#6 11 1.25 W/G + 11L 1.25 W/G

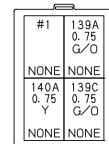

#1 140 0.75 Y + 140A 0.75 Y

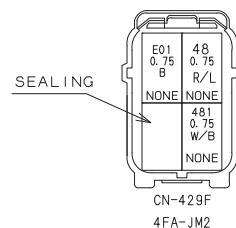

INSERT SEALING ON ALL EMPTY PINS

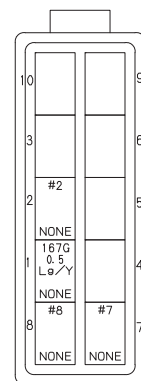
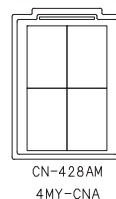
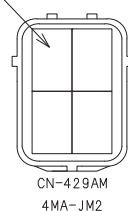

#2 165 0.75 Gr/R + 165 0.75 Gr/R
#7 750r 0.75 W/R + 750s 0.75 W/R
#8 E019 0.75 B + E020 0.75 B

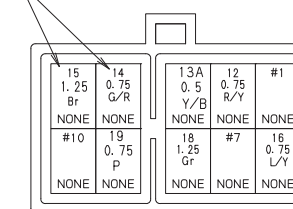
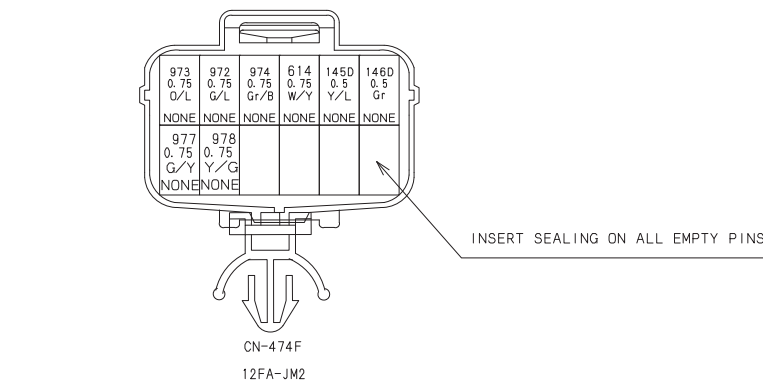
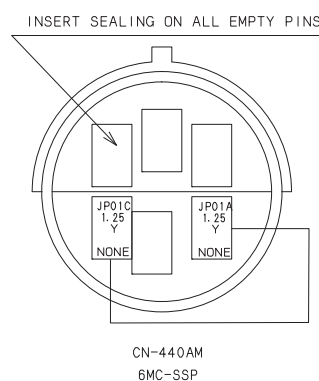

#1 11 1.25 W/G + 11A 1.25 W/G
#7 17 1.25 O + 17A 0.75 O
#10 20 1.25 W/L + 20G 1.25 W/L

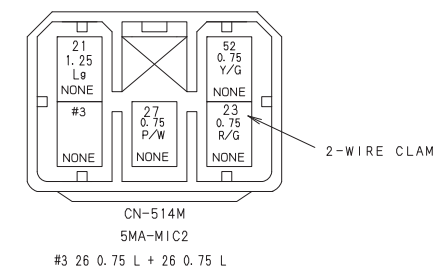
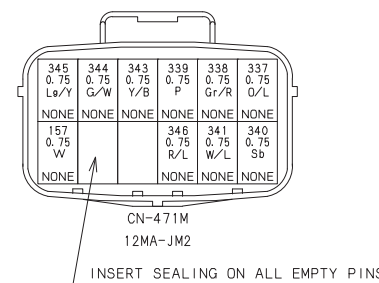
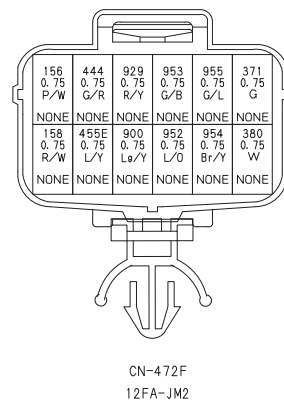
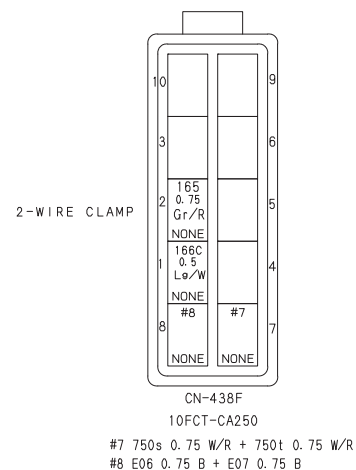
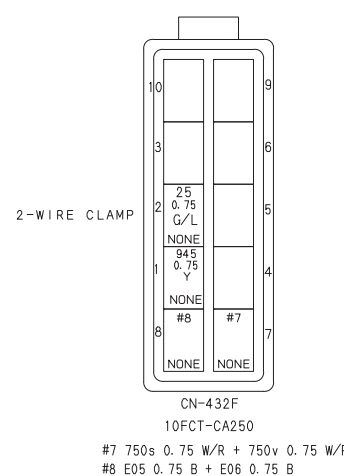
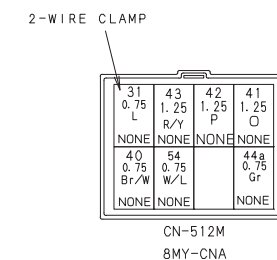
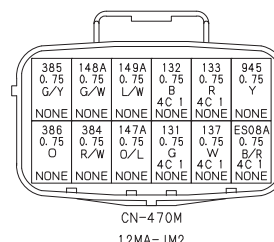

10. ELECTRIC SYSTEM

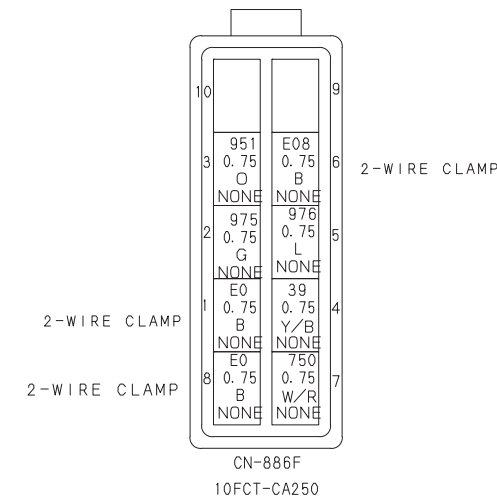
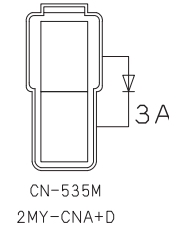
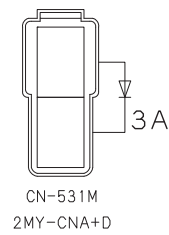
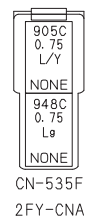
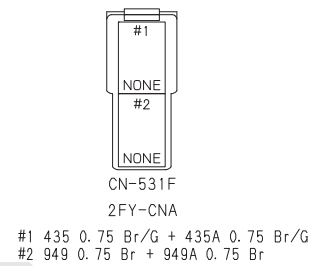
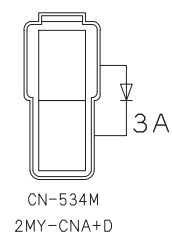
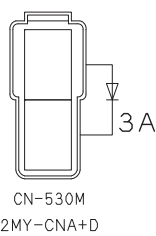
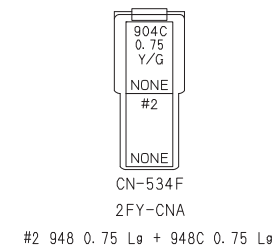
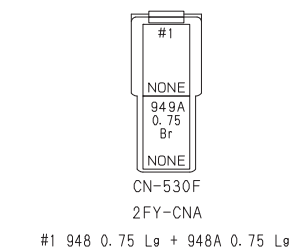
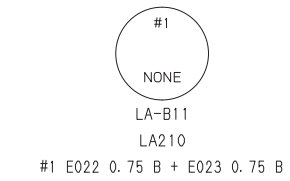
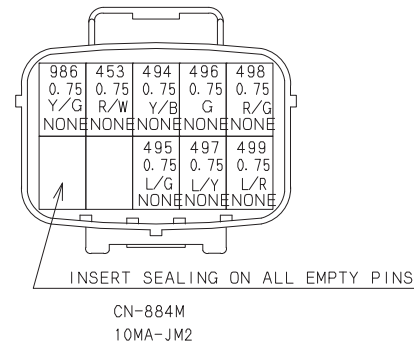
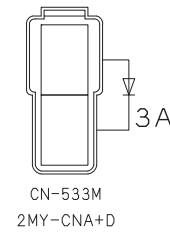
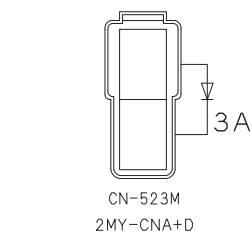
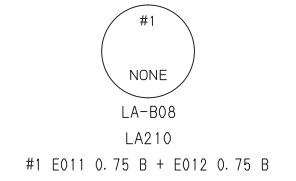
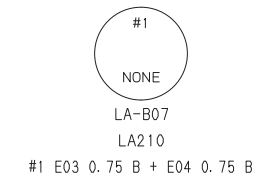
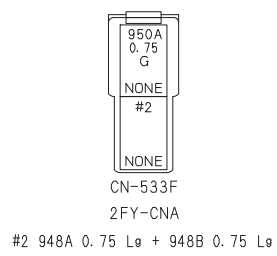
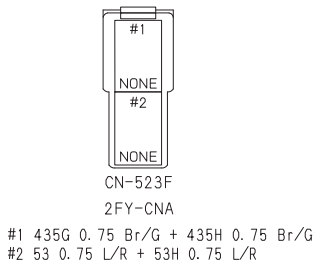
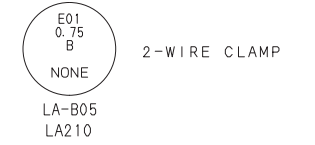
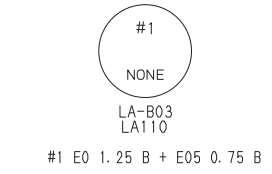
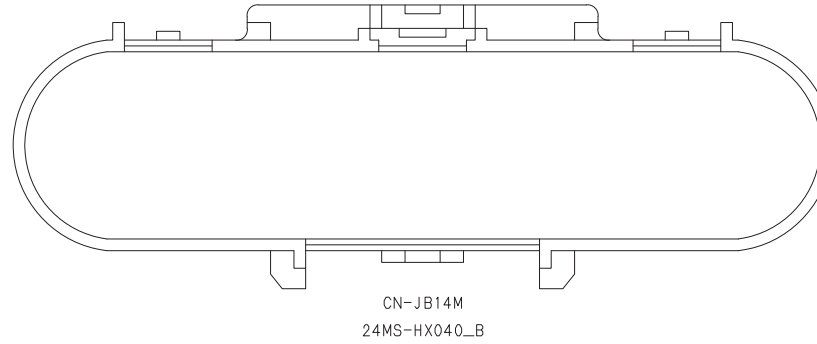
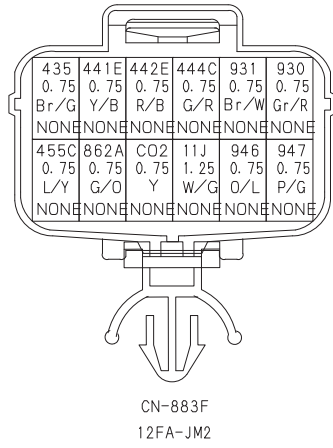
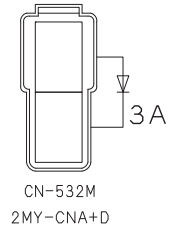
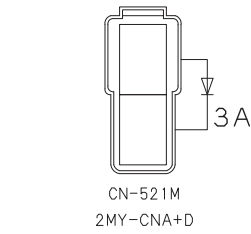
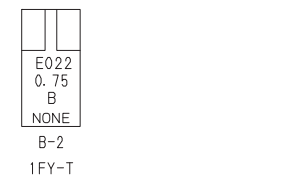
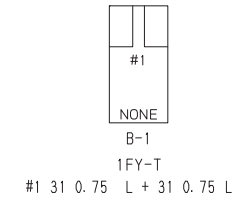
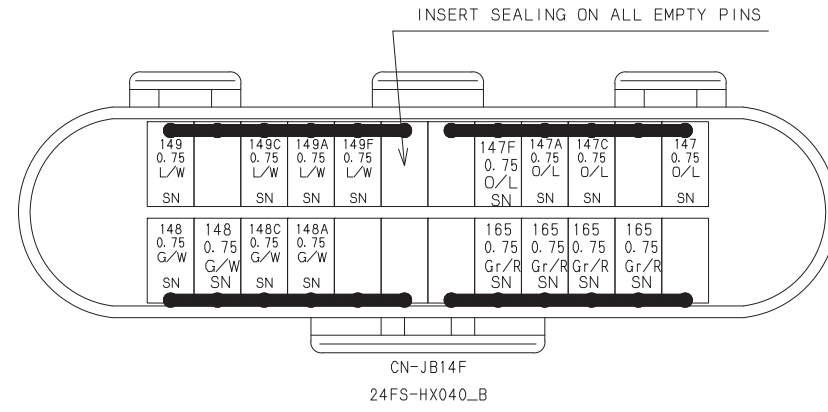
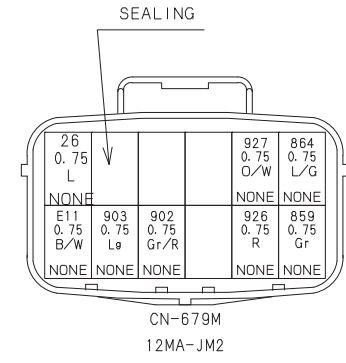
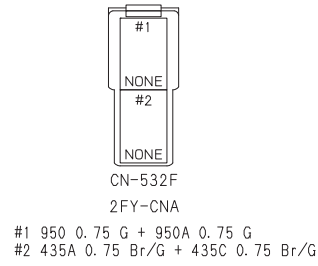
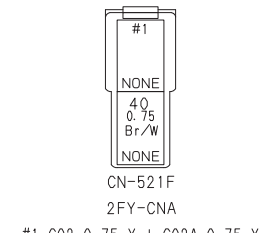

WIRE No. AND WIRE COLOR LIST

No.	COLOR	TYPE	SIZE	F R O M	2-WIRE CLAMP No.	CONNECTION	2-WIRE CLAMP No.	TO
11L	W/G	AVSS	1.25	CN-473F			DS-B15	CN-425F
11A	W/G	AVSS	1.25	CN-511M	DS-B01		DS-B15	CN-425F
11H	W/G	AVSS	1.25	CN-292F	DS-B01			JS-B07
11J	W/G	AVSS	1.25	JS-B07				CN-883F
11	W/G	AVSS	1.25	JS-B07				CN-293M
12	R/Y	AVSS	0.75	CN-31F				CN-511M
13A	Y/B	AVSS	0.5	CN-511M				CN-292F
14	G/R	AVSS	0.75	CN-292F			DS-B212	CN-511M
14	G/R	AVSS	0.75	CN-404F			DS-B212	CN-511M
15	Br	AVSS	1.25	CN-424F	DS-B213			CN-401M
15	Br	AVSS	1.25	CN-424F	DS-B213			JS-B122
15	Br	AVSS	0.75	CN-440F				JS-B122
15	Br	AVSS	1.25	CN-511M	DS-B214			JS-B122
15	Br	AVSS	1.25	CN-511M	DS-B214			CN-31F
16	L/Y	AVSS	0.75	CN-511M				CN-424F
17	O	AVSS	1.25	CN-292F			DS-B02	CN-511M
17A	O	AVSS	0.75	CN-37F			DS-B02	CN-511M
18	Gr	AVSS	1.25	CN-292F				CN-511M
19	P	AVSS	0.75	CN-511M				CN-292F
20	W/L	AVSS	1.25	CN-292F			DS-B04	CN-511M
20G	W/L	AVSS	1.25	CN-292F			DS-B04	CN-511M
21	Lg	AVSS	0.75	CN-514M				CN-292F
23	R/G	AVSS	0.75	CN-514M	DS-B215			CN-292F
23A	R/G	AVSS	0.75	CN-514M	DS-B215			CN-292F
25	G/L	AVSS	0.75	CN-293M			DS-B216	CN-432F
25	G/L	AVSS	0.75	CN-216F			DS-B216	CN-432F
26	L	AVSS	0.75	JS-B50				CN-679M
26	L	AVSS	0.75	CN-514M	DS-B06			CN-473F
26	L	AVSS	0.75	CN-514M	DS-B06			JS-B50
26	L	AVSS	0.75	CN-218F				JS-B50
27	P/W	AVSS	0.75	CN-514M				CN-427F
31	L	AVSS	0.75	CN-37F			DS-B07	CN-512M
31	L	AVSS	0.75	JS-B05			DS-B07	CN-512M
31	L	AVSS	0.75	JS-B05			DS-B24	B-1
31	L	AVSS	0.75	CN-404F			DS-B24	B-1
31	L	AVSS	0.75	CN-304M				JS-B05
39	R/W	AVSS	0.75	CN-886F				CN-301M
40	Br/W	AVSS	0.75	CN-521F				CN-512M
41	O	AVSS	1.25	CN-404F				CN-512M
42	P	AVSS	1.25	CN-512M				CN-404F
43	R/Y	AVSS	1.25	CN-512M				CN-404F
44	O/W	AVSS	0.75	JS-B46				CN-31F
44	O/W	AVSS	0.75	JS-B46				CN-293M
44	O/W	AVSS	0.75	JS-B46				CN-473F
44a	Gr	AVSS	0.75	CN-512M				CN-297M
48	R/L	AVSS	0.75	CN-429F				CN-293M
53	L/R	AVSS	0.75	CN-425F	DS-B16			CN-404F
53	L/R	AVSS	0.75	CN-425F	DS-B16			CN-523F
53	L/R	AVSS	0.75	JS-B114			DS-B18	CN-523F
53	L/R	AVSS	0.75	JS-B114				CN-305M
53	L/R	AVSS	0.75	JS-B114				JS-B123
53	L/R	AVSS	0.75	CN-31F				JS-B123
53	L/R	AVSS	0.75	CN-31F				JS-B123
54	W/L	AVSS	0.75	CN-425F				CN-512M
138	G/B	AVSS	0.75	CN-293M				CN-31F
139	G/O	AVSS	0.75	CN-293M				JS-B26
139A	G/O	AVSS	0.75	CN-428F				JS-B26
139C	G/O	AVSS	0.75	CN-428F				JS-B26
140	Y	AVSS	0.75	CN-31F			DS-B218	CN-428F
140A	Y	AVSS	0.75	CN-428F			DS-B218	CN-428F
145	Y/L	AVSS	0.5	CN-293M				JS-B124
145	Y/L	AVSS	0.5	CN-474F				JS-B124
145	Y/L	AVSS	0.75	CN-403F				JS-B124
146	Gr	AVSS	0.5	CN-293M				JS-B125
146	Gr	AVSS	0.5	CN-474F				JS-B125
146	Gr	AVSS	0.75	CN-403F				JS-B125
147	O/L	AVSS	0.75	CN-31F				CN-293M
147A	O/L	AVSS	0.75	CN-31F				CN-470M
147C	O/L	AVSS	0.75	CN-31F				CN-404F
147F	O/L	AVSS	0.75	CN-31F				CN-31F
148	G/W	AVSS	0.75	CN-31F				CN-31F
148	G/W	AVSS	0.75	CN-31F				CN-293M
148A	G/W	AVSS	0.75	CN-31F				CN-470M
148C	G/W	AVSS	0.75	CN-31F				CN-403F
149	L/W	AVSS	0.75	CN-31F				CN-31F
149A	L/W	AVSS	0.75	CN-31F				CN-470M
149C	L/W	AVSS	0.75	CN-31F				CN-403F
149F	L/W	AVSS	0.75	CN-31F				CN-293M
156	P/W	AVSS	0.75	CN-472F				CN-293M
157	W	AVSS	0.75	CN-471M				CN-293M
158	R/W	AVSS	0.75	CN-472F				CN-293M

No.	COLOR	TYPE	SIZE	F R O M	2-WIRE CLAMP No.	CONNECTION	2-WIRE CLAMP No.	TO
160	G	AVSS	0.75	CN-293M			DS-B45	CN-424F
160A	G	AVSS	0.75	CN-37F			DS-B45	CN-424F
161	Y/R	AVSS	0.75	CN-424F	DS-B46			CN-293M
161A	Y/R	AVSS	0.75	CN-424F	DS-B46			CN-401M
162	Y/G	AVSS	0.75	CN-293M				CN-440F
165	Gr/R	AVSS	0.75	CN-293M				CN-31F
165C	Gr/R	AVSS	0.75	CN-424F				CN-31F
165	Gr/R	AVSS	0.75	CN-438F	DS-B220			CN-31F
165	Gr/R	AVSS	0.75	CN-438F	DS-B220			CN-437F
165	Gr/R	AVSS	0.75	CN-436F			DS-B221	CN-437F
166	Lg/W	AVSS	0.5	JS-B115				CN-293M
166C	Lg/W	AVSS	0.5	JS-B115				CN-438F
166E	Lg/W	AVSS	0.5	JS-B115				CN-404F
167	Lg/Y	AVSS	0.5	JS-B116				CN-293M
167E	Lg/Y	AVSS	0.5	JS-B116				CN-404F
167G	Lg/Y	AVSS	0.5	JS-B116				CN-437F
168	Lg/R	AVSS	0.5	CN-293M			DS-B222	CN-436F
168	Lg/R	AVSS	0.75	CN-31F			DS-B222	CN-436F
170	R/G	AVSS	0.5	CN-293M				CN-32F
172	Gr/L	AVSS	1.25	CN-440F				CN-292F
176	Gr/W	AVSS	0.75	CN-293M				JS-B121
176	Gr/W	AVSS	0.75	CN-403F				JS-B121
176	Gr/W	AVSS	0.75	CN-31F				JS-B121
212	G/W	AVSS	0.75	CN-404F				CN-33F
213	Y/W	AVSS	0.75	CN-33F				CN-404F
214	R/W	AVSS	0.75	CN-404F				CN-33F
224	Gr/B	AVSS	0.75	CN-31F				CN-440F
318	R/G	AVSS	0.75	CN-292F				CN-222F
319	G/B	AVSS	0.75	CN-222F				CN-292F
320	W/Y	AVSS	0.75	CN-222F				CN-292F
324	O/L	AVSS	0.75	CN-304M				CN-417F
325	W/O	AVSS	0.75	CN-417F				CN-304M
326	Gr/R	AVSS	0.75	CN-304M				CN-417F
337	O/L	AVSS	0.75	CN-471M				CN-305M
338	Gr/R	AVSS	0.75	CN-471M				CN-305M
339	P	AVSS	0.75	CN-471M				CN-305M
340	Sb	AVSS	0.75	CN-471M				CN-305M
341	W/L	AVSS	0.75	CN-305M				CN-471M
343	Y/B	AVSS	0.75	CN-305M				CN-471M
344	G/W	AVSS	0.75	CN-471M				CN-305M
345	Lg/Y	AVSS	0.75	CN-305M				CN-471M
346	R/L	AVSS	0.75	CN-305M				CN-471M
383	R	AVSS	0.75	CN-306F				CN-419M
384	R/W	AVSS	0.75	CN-306F				CN-470M
385	G/Y	AVSS	0.75	CN-470M				CN-306F
386	O	AVSS	0.75	CN-306F				CN-470M
394	Lg	AVSS	0.75	CN-31F				CN-416F
395	R/L	AVSS	0.75	CN-304M			DS-B230	CN-418M
395	R/L	AVSS	0.75	CN-424F			DS-B230	CN-418M
402	V/W	AVSS	0.75	CN-304M				JS-B21
402A	V/W	AVSS	0.75	CN-37F				JS-B21
402C	V/W	AVSS	0.75	JS-B21				CN-415F
418	W/R	AVSS	0.75	CN-424F				CN-305M
429	G	AVSS	0.75	CN-301M				CN-32F
435	Br/G	AVSS	0.75	CN-531F	DS-B35			CN-31F
435	Br/G	AVSS	0.75	CN-531F	DS-B35			CN-532F
435	Br/G	AVSS	0.75	JS-B126			DS-B38	CN-532F
435	Br/G	AVSS	0.75	JS-B126				CN-306F
435	Br/G	AVSS	0.75	JS-B126				CN-883F
435	Br/G	AVSS	0.75	JS-B126				CN-523F
445	R/Y	AVSS	0.75	CN-293M				CN-401M
476	O	AVSS	0.75	CN-31F				CN-301M
481	W/B	AVSS	0.75	CN-429F				CN-33F
485	Gr/L	AVSS	0.75	CN-31F				CN-306F
501	Br/W	AVSS	0.75	CN-31F				CN-401M
502A	G/Y	AVSS	0.75	CN-401M				CN-31F
503A	L	AVSS	0.75	CN-31F				CN-401M
614	W/Y	AVSS	0.75	CN-474F				CN-304M
750Y	W/R	AVSS	0.75	JS-B120				CN-401M
750p	W/R	AVSS	1.25	JS-B120				CN-304M
750a	W/R	AVSS	0.75	JS-B120			DS-B59	CN-432F
750r	W/R	AVSS	0.75	CN-438F	DS-B61		DS-B59	CN-432F
750s	W/R	AVSS	0.75	CN-438F	DS-B61		DS-B100	CN-437F
750t	W/R	AVSS	0.75	CN-436F	DS-B101		DS-B100	CN-437F
750u	W/R	AVSS	0.75	CN-436F	DS-B101		DS-B102	CN-218F
750v	W/R	AVSS	0.75	CN-218F	DS-B106		DS-B102	CN-218F
750s	W/R	AVSS	0.75	CN-218F	DS-B106		DSA95	CN-216F
750T	W/R	AVSS	0.75	CN-216F	DS-B226		DSA95	CN-216F
750	W/R	AVSS	0.75	CN-216F	DS-B226			CN-886F

No.	COLOR	TYPE	SIZE	F R O M	2-WIRE CLAMP No.	CONNECTION	2-WIRE CLAMP No.	TO
859	Gr	AVSS	0.75	CN-37F				CN-679M
861	L/Y	AVSS	0.75	CN-401M			DS-B41	CN-418M
861A	L/Y	AVSS	0.75	CN-31F			DS-B41	CN-418M
862	G/O	AVSS	0.75	JS-B10				CN-32F
862A	G/O	AVSS	0.75	CN-883F				JS-B10
862C	G/O	AVSS	0.75	CN-473F				JS-B10
864	L/G	AVSS	0.75	CN-37F				CN-679M
900	Lg/Y	AVSS	0.75	CN-472F				CN-304M
901	Y/L	AVSS	0.75	CN-411F				CN-304M
902</								

10. ELECTRIC SYSTEM

FLOOR HARNESS B

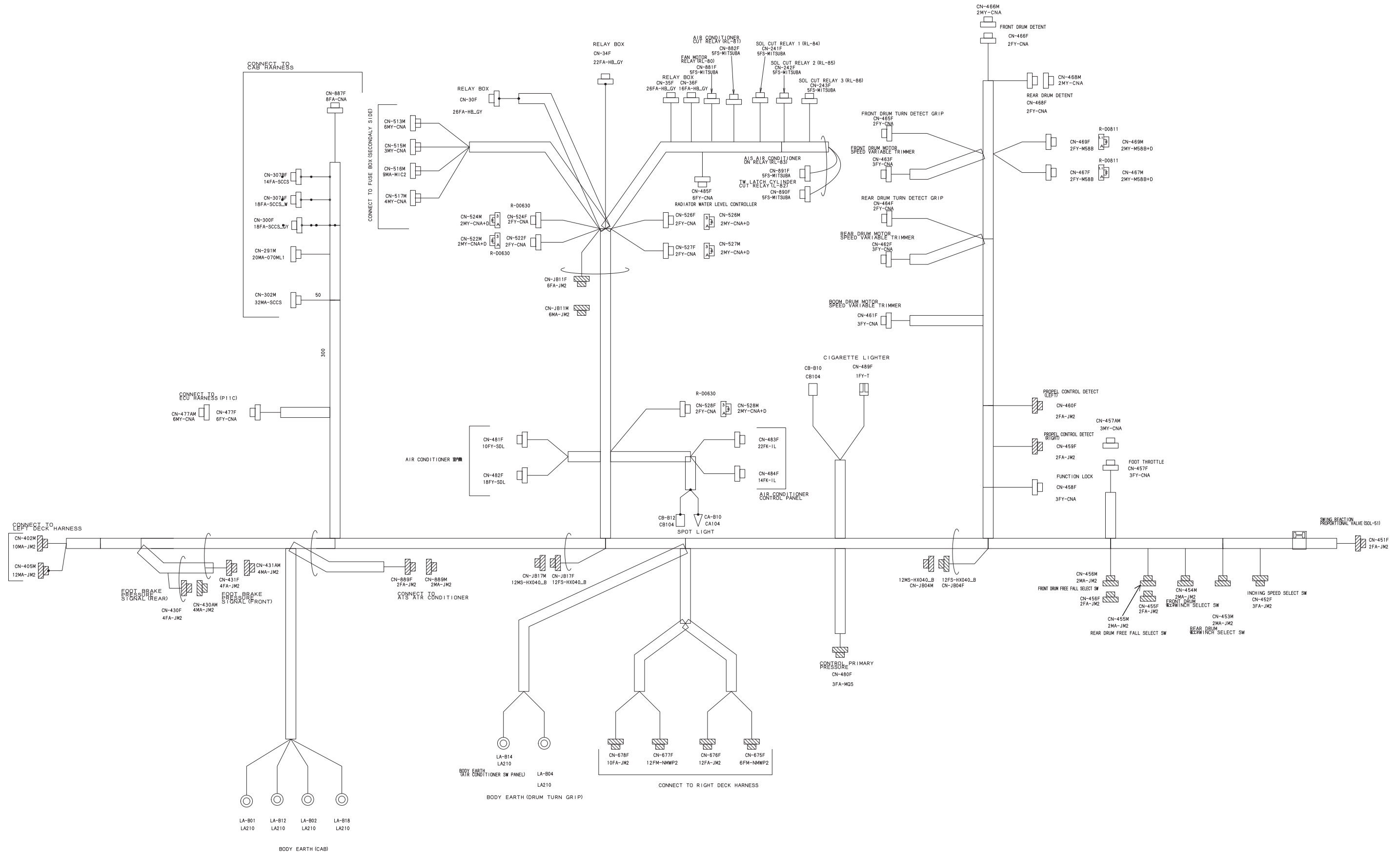

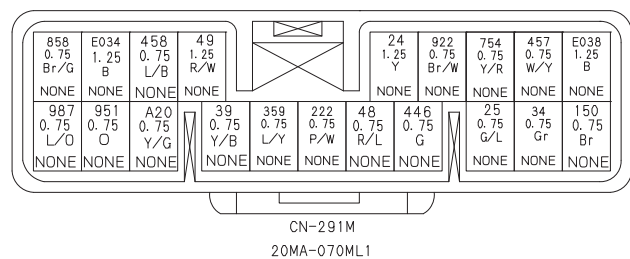
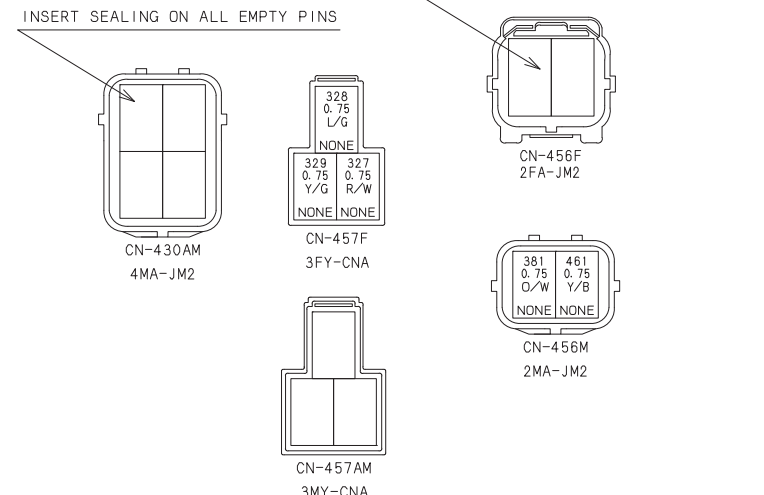
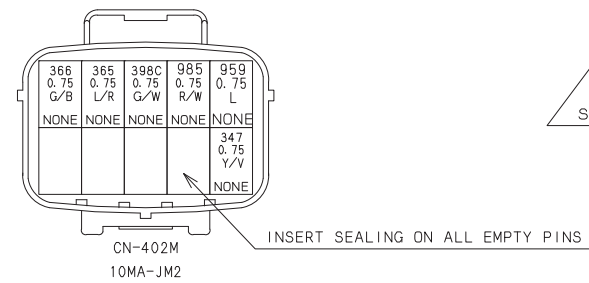
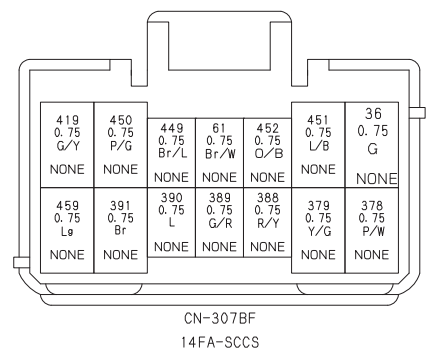
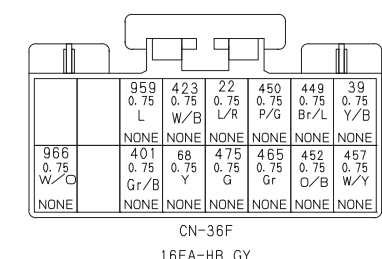
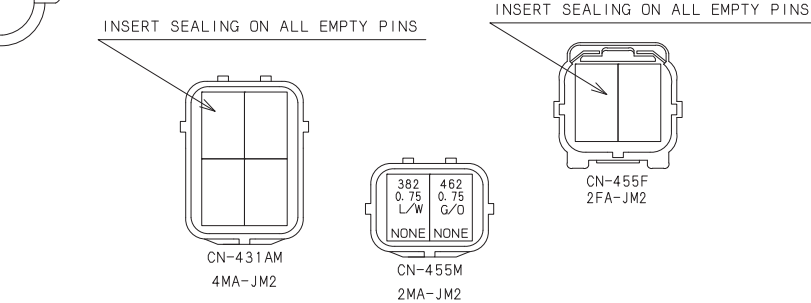
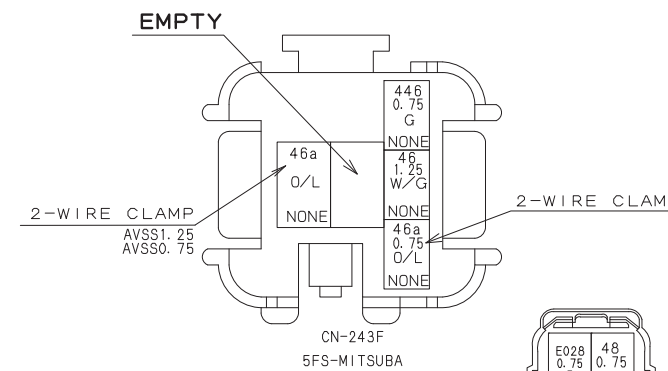
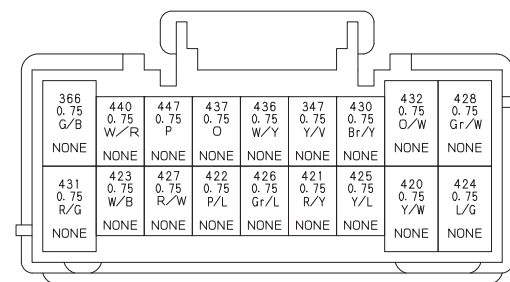
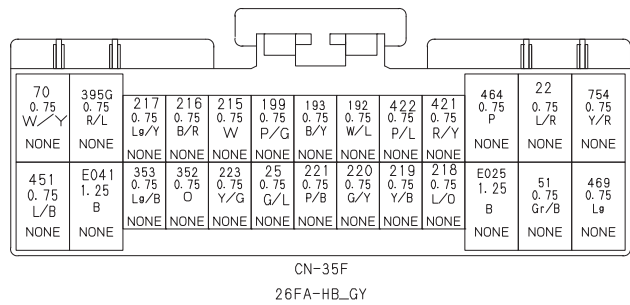
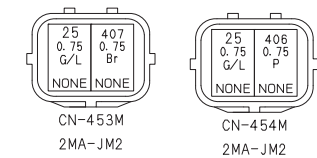
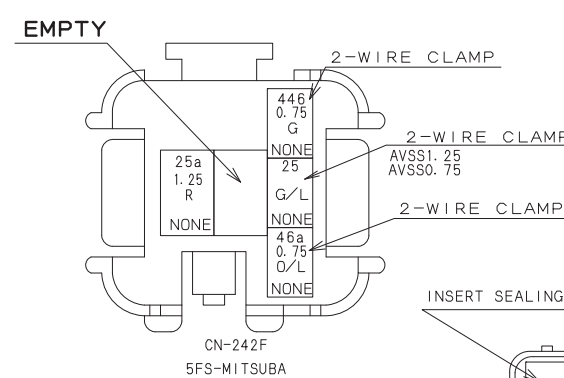
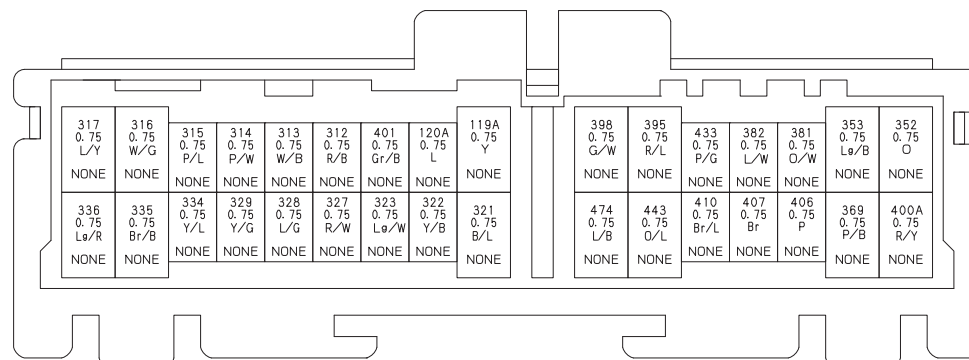
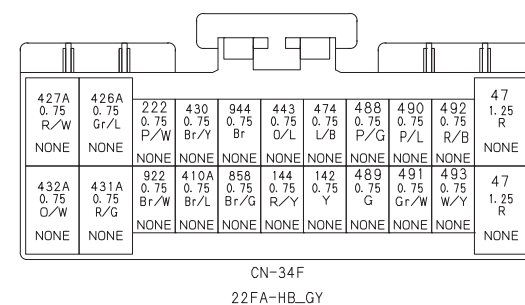
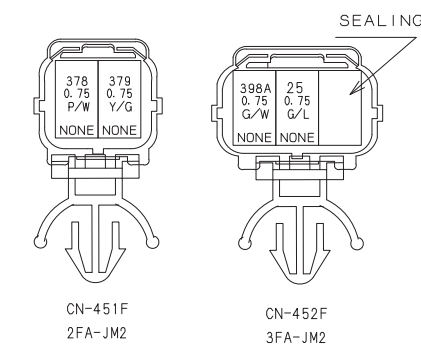
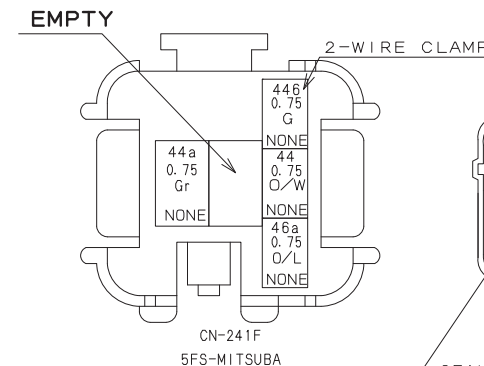
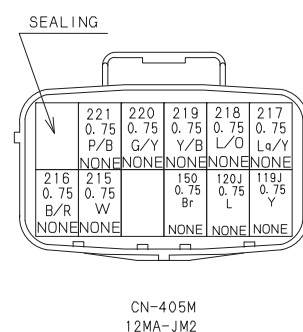
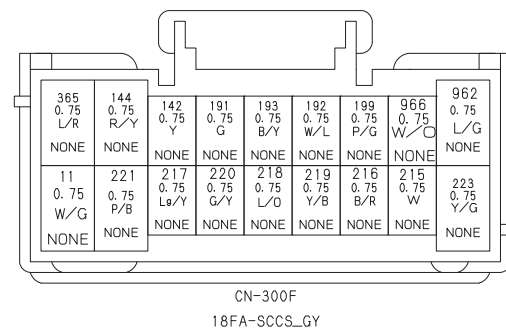
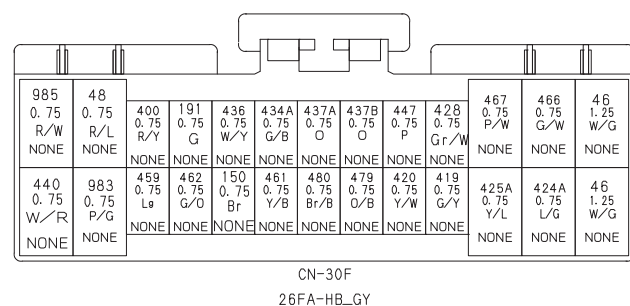

10. ELECTRIC SYSTEM

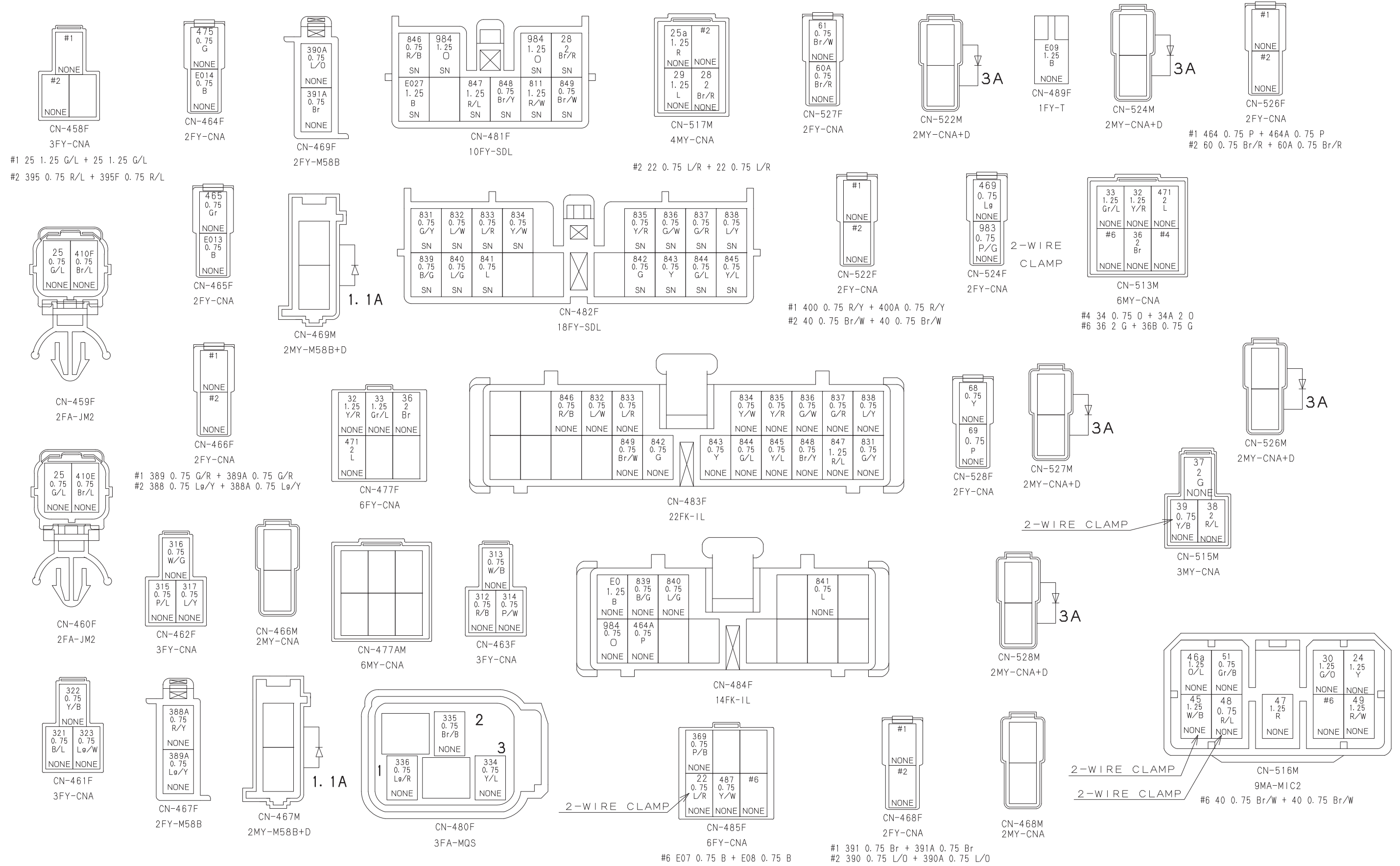

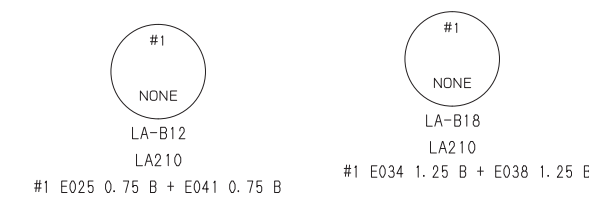
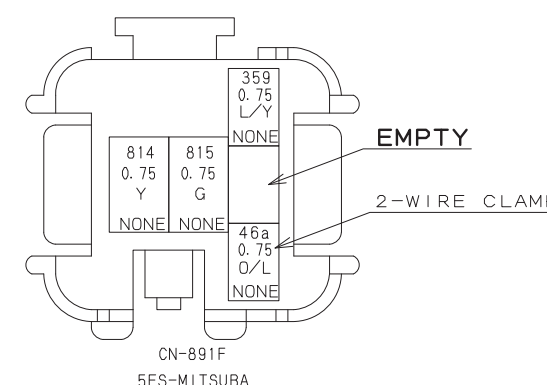
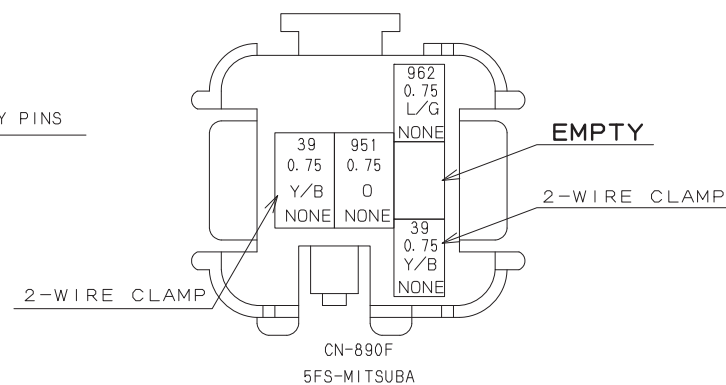
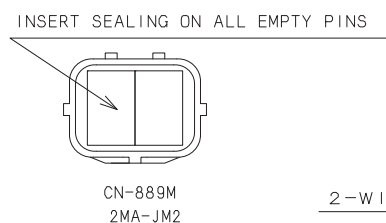
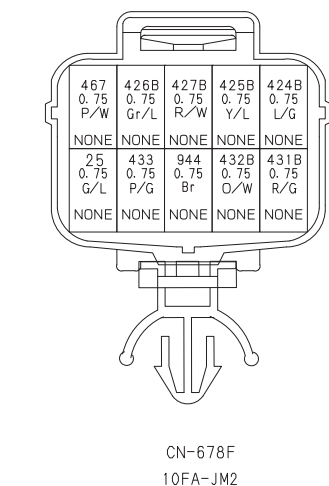
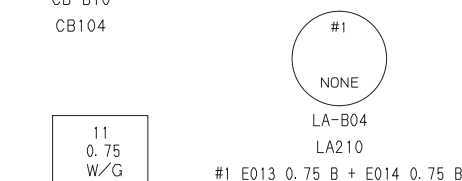
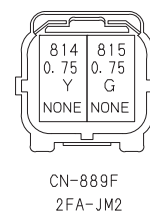
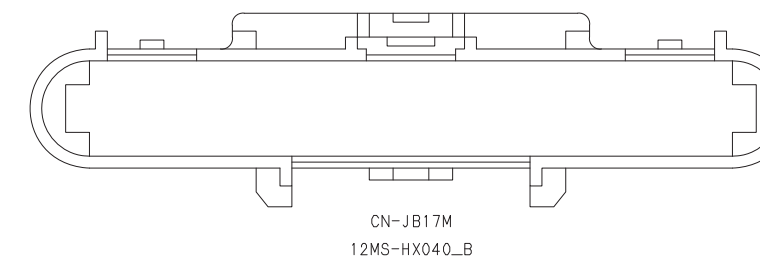
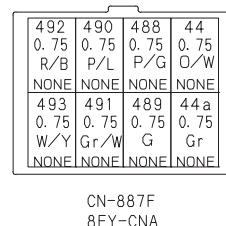
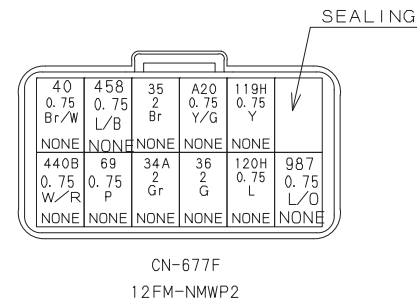
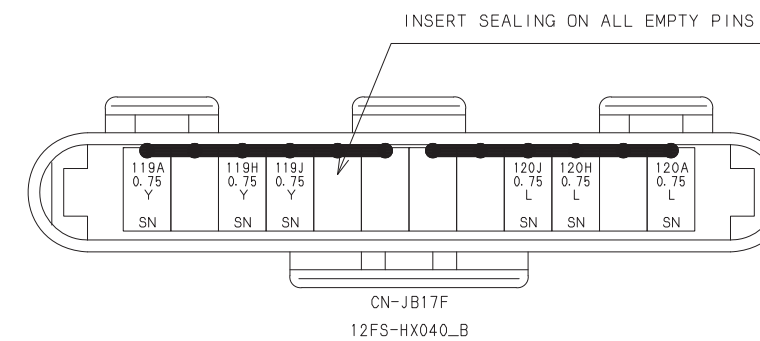
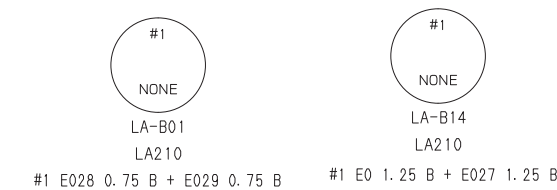
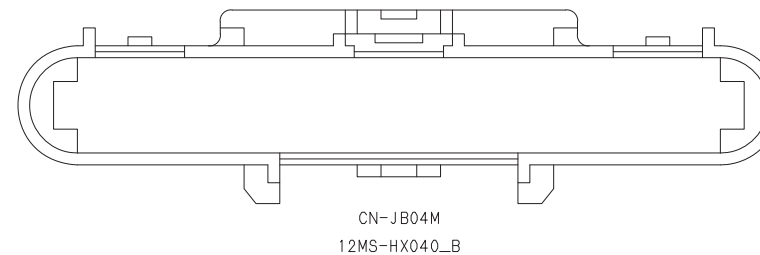
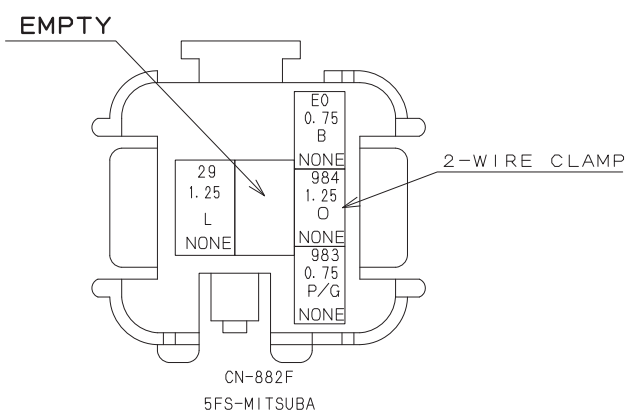
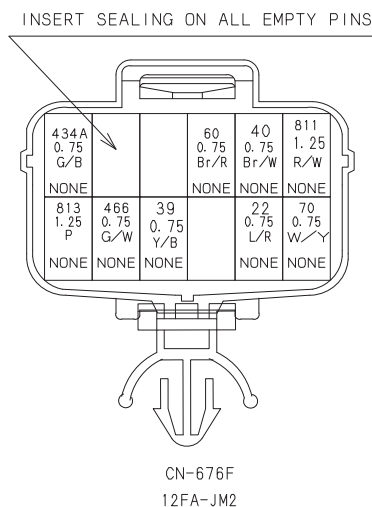
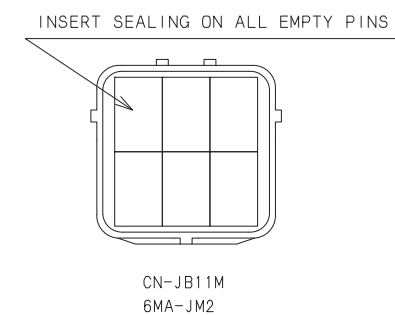
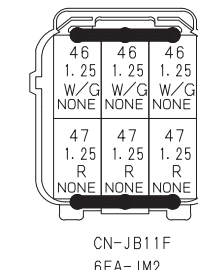
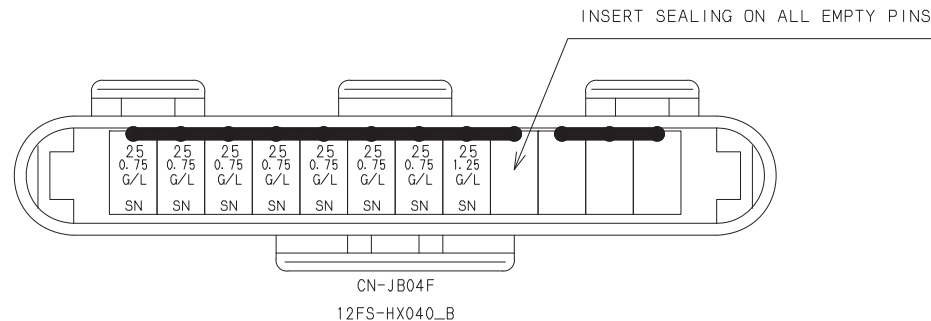
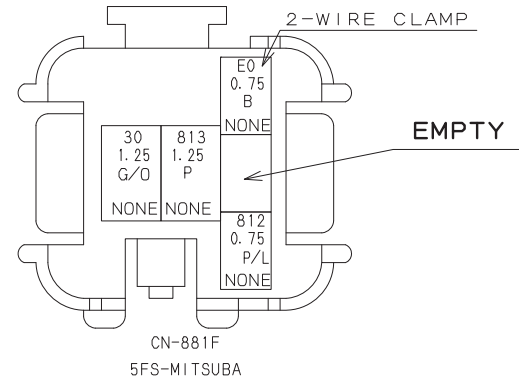
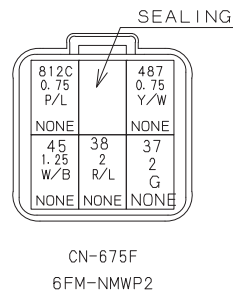

10. ELECTRIC SYSTEM

WIRE No. AND WIRE COLOR LIST

No.	COLOR	TYPE	SIZE	FROM	2-WIRE CLAMP No.	CONNECTION	2-WIRE CLAMP No.	TO
11	W/G	AVSS	0.75	CB-B12				CN-300F
22	L/R	AVSS	0.75	CN-35F				JS-B12
22	L/R	AVSS	0.75	CN-36F				JS-B12
22	L/R	AVSS	0.75	CN-485F	DS-B200			JS-B12
22	L/R	AVSS	0.75	CN-485F	DS-B200		DS-B08	CN-517M
22	L/R	AVSS	0.75	CN-676F			DS-B08	CN-517M
24	Y	AVSS	1.25	CN-291M				CN-516M
25	G/L	AVSS	0.75	CN-242F	DS-B05			CN-291M
25	G/L	AVSS	1.25	CN-242F	DS-B05		DS-B40	CN-458F
25	G/L	AVSS	1.25	CN-JB04F			DS-B40	CN-458F
25	G/L	AVSS	0.75	CN-JB04F				CN-454M
25	G/L	AVSS	0.75	CN-JB04F				CN-453M
25	G/L	AVSS	0.75	CN-JB04F				CN-35F
25	G/L	AVSS	0.75	CN-JB04F				CN-452F
25	G/L	AVSS	0.75	CN-JB04F				CN-459F
25	G/L	AVSS	0.75	CN-JB04F				CN-460F
25	G/L	AVSS	0.75	CN-JB04F				CN-678F
25a	R	AVSS	1.25	CN-517M				CN-242F
28	Br/R	AVS	2	CN-517M				CN-481F
29	L	AVSS	1.25	CN-517M				CN-882F
30	G/O	AVSS	1.25	CN-881F				CN-516M
32	Y/R	AVSS	1.25	CN-513M				CN-477F
33	Gr/L	AVS	1.25	CN-477F				CN-513M
34	Gr	AVSS	0.75	CN-513M	DS-B09			CN-291M
34A	Gr	AVS	2	CN-513M	DS-B09			CN-677F
35	Br	AVS	2	CN-513M				JS-B113
35	Br	AVS	2	CN-477F				JS-B113
35	Br	AVS	2	CN-677F				JS-B113
36	G	AVS	2	CN-677F		DS-B10		CN-513M
36	G	AVSS	0.75	CN-307BF		DS-B10		CN-513M
37	G	AVS	2	CN-515M				CN-675F
38	R/L	AVS	2	CN-515M				CN-675F
39	Y/B	AVSS	0.75	CN-291M		DS-B201		CN-515M
39	Y/B	AVSS	0.75	CN-890F	DS-B201		DS-B201	CN-515M
39	Y/B	AVSS	0.75	CN-890F	DS-B231		DS-B232	CN-890F
39	Y/B	AVSS	0.75	JS-B104		DS-B232		CN-890F
39	Y/B	AVSS	0.75	JS-B104				CN-36F
39	Y/B	AVSS	0.75	JS-B104				CN-676F
40	Br/W	AVSS	0.75	CN-676F		DS-B12		CN-516M
40	Br/W	AVSS	0.75	CN-522F	DS-B22		DS-B12	CN-516M
40	Br/W	AVSS	0.75	CN-522F	DS-B22			CN-677F
44	O/W	AVSS	0.75	CN-887F				CN-241F
44a	Gr	AVSS	0.75	CN-887F				CN-241F
45	W/B	AVSS	1.25	CN-516M	DS-B202			CN-675F
45	W/B	AVSS	1.25	CN-516M	DS-B202			CB-B10
46	W/G	AVSS	1.25	CN-JB11F				CN-243F
46	W/G	AVSS	1.25	CN-JB11F				CN-30F
46	W/G	AVSS	1.25	CN-JB11F				CN-30F
46a	O/L	AVSS	0.75	CN-516M		DS-B50		CN-243F
46a	O/L	AVSS	0.75	CN-891F	DS-B51		DS-B50	CN-243F
46a	O/L	AVSS	0.75	CN-891F	DS-B51		DS-B52	CN-243F
46a	O/L	AVSS	0.75	CN-242F	DS-B53		DS-B52	CN-243F
46a	O/L	AVSS	0.75	CN-242F	DS-B53			CN-241F
47	R	AVSS	1.25	CN-JB11F				CN-516M
47	R	AVSS	1.25	CN-JB11F				CN-34F
47	R	AVSS	1.25	CN-JB11F				CN-34F
48	R/L	AVSS	0.75	CN-516M	DS-B204			CN-30F
48	R/L	AVSS	0.75	CN-516M	DS-B204			JS-B114
48	R/L	AVSS	0.75	CN-291M				JS-B114
48	R/L	AVSS	0.75	CN-430F				JS-B114
48	R/L	AVSS	0.75	CN-431F				JS-B114
49	R/W	AVSS	1.25	CN-291M				CN-516M
51	Gr/B	AVSS	0.75	CN-516M				CN-35F
60	Br/R	AVSS	0.75	CN-676F		DS-B33		CN-526F
60A	Br/R	AVSS	0.75	CN-527F		DS-B33		CN-526F
61	Br/W	AVSS	0.75	CN-527F				CN-307BF
68	Y	AVSS	0.75	CN-36F				CN-528F
69	P	AVSS	0.75	CN-528F				CN-677F
70	W/Y	AVSS	0.75	CN-676F				CN-35F
142	Y	AVSS	0.75	CN-300F				CN-34F
144	R/Y	AVSS	0.75	CN-300F				CN-34F
150	Br	AVSS	0.75	CN-30F				JS-B100
150	Br	AVSS	0.75	CN-291M				JS-B100
150	Br	AVSS	0.75	CN-405M				JS-B100
191	G	AVSS	0.75	CN-300F				CN-30F
192	W/L	AVSS	0.75	CN-300F				CN-35F
193	B/Y	AVSS	0.75	CN-300F				CN-35F
199	P/G	AVSS	0.75	CN-300F				CN-35F
215	W	AVSS	0.75	CN-300F				JS-B106
215	W	AVSS	0.75	CN-405M				JS-B106
215	W	AVSS	0.75	CN-35F				JS-B106
216	B/R	AVSS	0.75	CN-300F				JS-B107
216	B/R	AVSS	0.75	CN-405M				JS-B107
216	B/R	AVSS	0.75	CN-35F				JS-B107
217	Lg/Y	AVSS	0.75	CN-300F				JS-B108
217	Lg/Y	AVSS	0.75	CN-405M				JS-B108
217	Lg/Y	AVSS	0.75	CN-35F				JS-B108

No.	COLOR	TYPE	SIZE	FROM	2-WIRE CLAMP No.	CONNECTION	2-WIRE CLAMP No.	TO
218	L/Y	AVSS	0.75	CN-300F				JS-B109
218	L/Y	AVSS	0.75	CN-405M				JS-B109
218	L/Y	AVSS	0.75	CN-35F				JS-B109
219	Y/B	AVSS	0.75	CN-300F				JS-B110
219	Y/B	AVSS	0.75	CN-405M				JS-B110
219	Y/B	AVSS	0.75	CN-35F				JS-B110
220	G/Y	AVSS	0.75	CN-300F				JS-B111
220	G/Y	AVSS	0.75	CN-405M				JS-B111
220	G/Y	AVSS	0.75	CN-35F				JS-B111
221	P/B	AVSS	0.75	CN-300F				JS-B112
221	P/B	AVSS	0.75	CN-405M				JS-B112
221	P/B	AVSS	0.75	CN-35F				JS-B112
222	P/W	AVSS	0.75	CN-291M				CN-34F
223	Y/G	AVSS	0.75	CN-35F				CN-300F
312	R/B	AVSS	0.75	CN-463F				CN-302M
313	W/B	AVSS	0.75	CN-463F				CN-302M
314	P/W	AVSS	0.75	CN-463F				CN-302M
315	P/L	AVSS	0.75	CN-302M				CN-462F
316	R/W	AVSS	0.75	CN-462F				CN-302M
317	L/Y	AVSS	0.75	CN-302M				CN-462F
321	B/L	AVSS	0.75	CN-461F				CN-302M
322	Y/B	AVSS	0.75	CN-302M				CN-461F
323	Lg/W	AVSS	0.75	CN-302M				CN-461F
327	R/W	AVSS	0.75	CN-457F				CN-302M
328	L/G	AVSS	0.75	CN-302M				CN-457F
329	Y/G	AVSS	0.75	CN-302M				CN-457F
334	Y/L	AVSS	0.75	CN-302M				CN-480F
335	Br/B	AVSS	0.75	CN-302M				CN-480F
336	Lg/R	AVSS	0.75	CN-302M				CN-480F
347	Y/L	AVSS	0.75	CN-307AF				CN-402M
352	O	AVSS	0.75	CN-302M				CN-35F
353	Lg/B	AVSS	0.75	CN-302M				CN-35F
359	L/Y	AVSS	0.75	CN-291M				CN-891F
365	L/R	AVSS	0.75	CN-300F				CN-402M
366	G/B	AVSS	0.75	CN-402M				CN-307AF
369	P/B	AVSS	0.75	CN-302M				CN-485F
381	O/W	AVSS	0.75	CN-302M				CN-456M
382	L/W	AVSS	0.75	CN-455M				CN-302M
395	R/L	AVSS	0.75	CN-302M		DS-B41		CN-458F
395F	R/L	AVSS	0.75	CN-35F		DS-B41		CN-458F
398	G/W	AVSS	0.75	JS-B101				CN-302M
398A	G/W	AVSS	0.75	JS-B101				CN-452F
398C	G/W	AVSS	0.75	JS-B101				CN-402M
400	R/Y	AVSS	0.75	CN-30F		DS-B23		CN-522F
400A	R/Y	AVSS	0.75	CN-302M		DS-B23		CN-522F
401	Gr/B	AVSS	0.75	CN-302M				CN-36F
406	P	AVSS	0.75	CN-454M				CN-302M
407	Br	AVSS	0.75	CN-453M				CN-302M
410F	Br/L	AVSS	0.75	JS-B105				CN-459F
410E	Br/L	AVSS	0.75	JS-B105				CN-460F
410C	Br/L	AVSS	0.75	JS-B105				CN-302M
410	Br/L	AVSS	0.75	JS-B105				CN-34F
419	G/Y	AVSS	0.75	CN-30F				CN-307BF
420	Y/W	AVSS	0.75	CN-307AF				CN-30F
421	R/Y	AVSS	0.75	CN-307AF				CN-35F
422	P/L	AVSS	0.75	CN-307AF				CN-35F
423	W/B	AVSS	0.75	CN-307AF				CN-36F
424	L/G	AVSS	0.75	CN-307AF				JS-B37
424A	L/G	AVSS	0.75	JS-B37				CN-30F
424B	L/G	AVSS	0.75	CN-678F				JS-B37
425	Y/L	AVSS	0.75	CN-307AF				JS-B38
425A	Y/L	AVSS	0.75	JS-B38				CN-30F
425B	Y/L	AVSS	0.75	CN-678F				JS-B38
426	Gr/L	AVSS	0.75	CN-307AF				JS-B39
426A	Gr/L	AVSS	0.75	JS-B39				CN-34F
426B	Gr/L	AVSS	0.75	JS-B39				CN-678F
427	R/W	AVSS	0.75	CN-307AF				JS-B40
427A	R/W	AVSS	0.75	JS-B40				CN-34F
427B	R/W	AVSS	0.75	CN-678F				JS-B40
428	Gr/W	AVSS	0.75	CN-307AF				CN-30F
430	Br/Y	AVSS	0.75	CN-34F				CN-307AF
431	R/G	AVSS	0.75	JS-B41				CN-307AF
431A	R/G	AVSS	0.75	JS-B41				CN-34F
431B	R/G	AVSS	0.75	CN-678F				JS-B41
432	O/W	AVSS	0.75	JS-B42				CN-307AF
432A	O/W	AVSS	0.75	JS-B42				CN-34F
432B	O/W	AVSS	0.75	JS-B42				CN-678F
433	P/G	AVSS	0.75	CN-302M				CN-678F
434A	G/B	AVSS	0.75	CN-30F				CN-678F
436	W/Y	AVSS	0.75	CN-30F				CN-307AF
437	O	AVSS	0.75	JS-B35				CN-307AF
437A	O	AVSS	0.75	CN-30F				JS-B35
437B	O	AVSS	0.75	CN-30F				JS-B35
440	W/R	AVSS	0.75	CN-307AF				JS-B34
440A	W/R	AVSS	0.75	JS-B34				CN-30F
440B	W/R	AVSS	0.75	JS-B34				CN-677F
443	O/L	AVSS	0.75	CN-34F				C

2.ELECTRICAL PART OF LOWER

SOL : SOLENOID VALVE
 SW : SWITCH
 PSW : PRESSURE SWITCH
 ATT : ATTACHMENT
 C/W : COUNTER WEIGHT
 CB/W : CARBODY WEIGHT

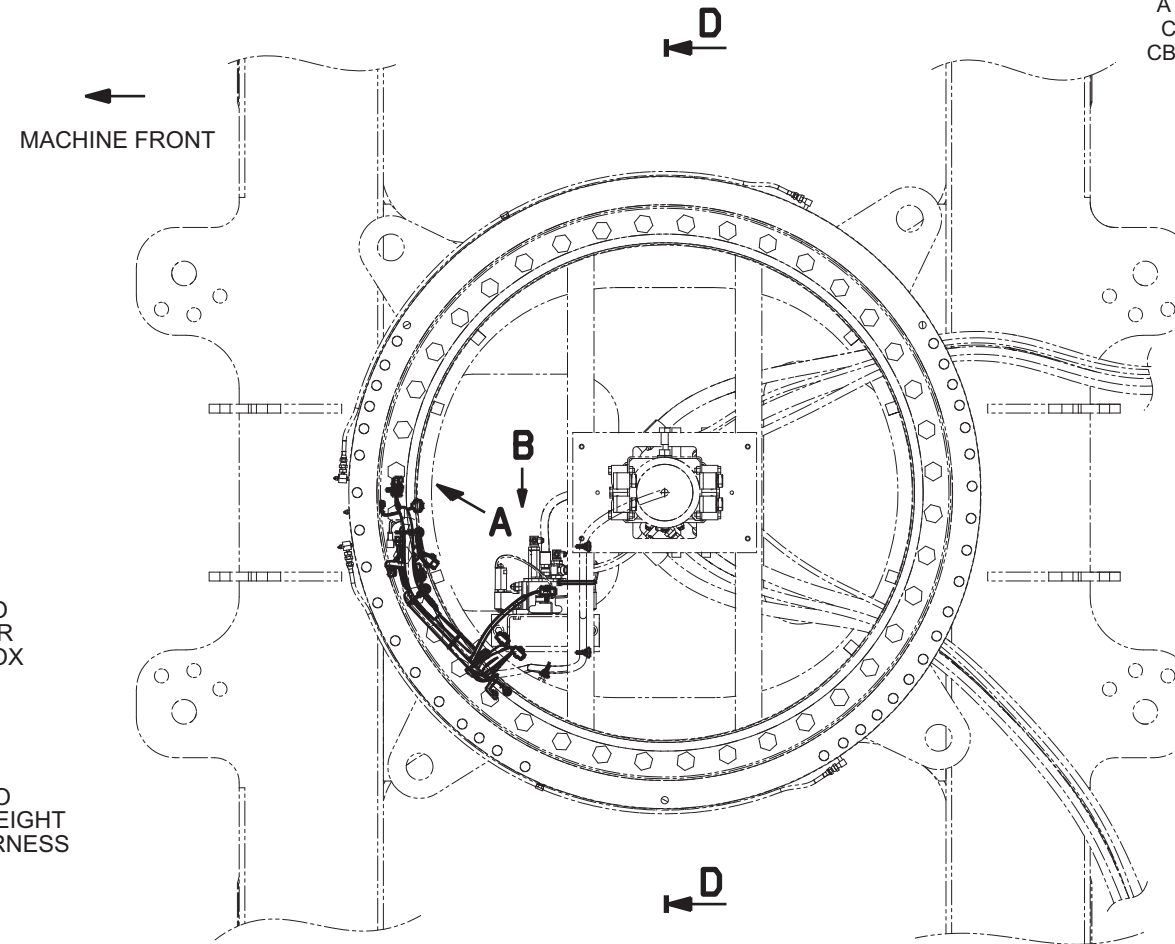
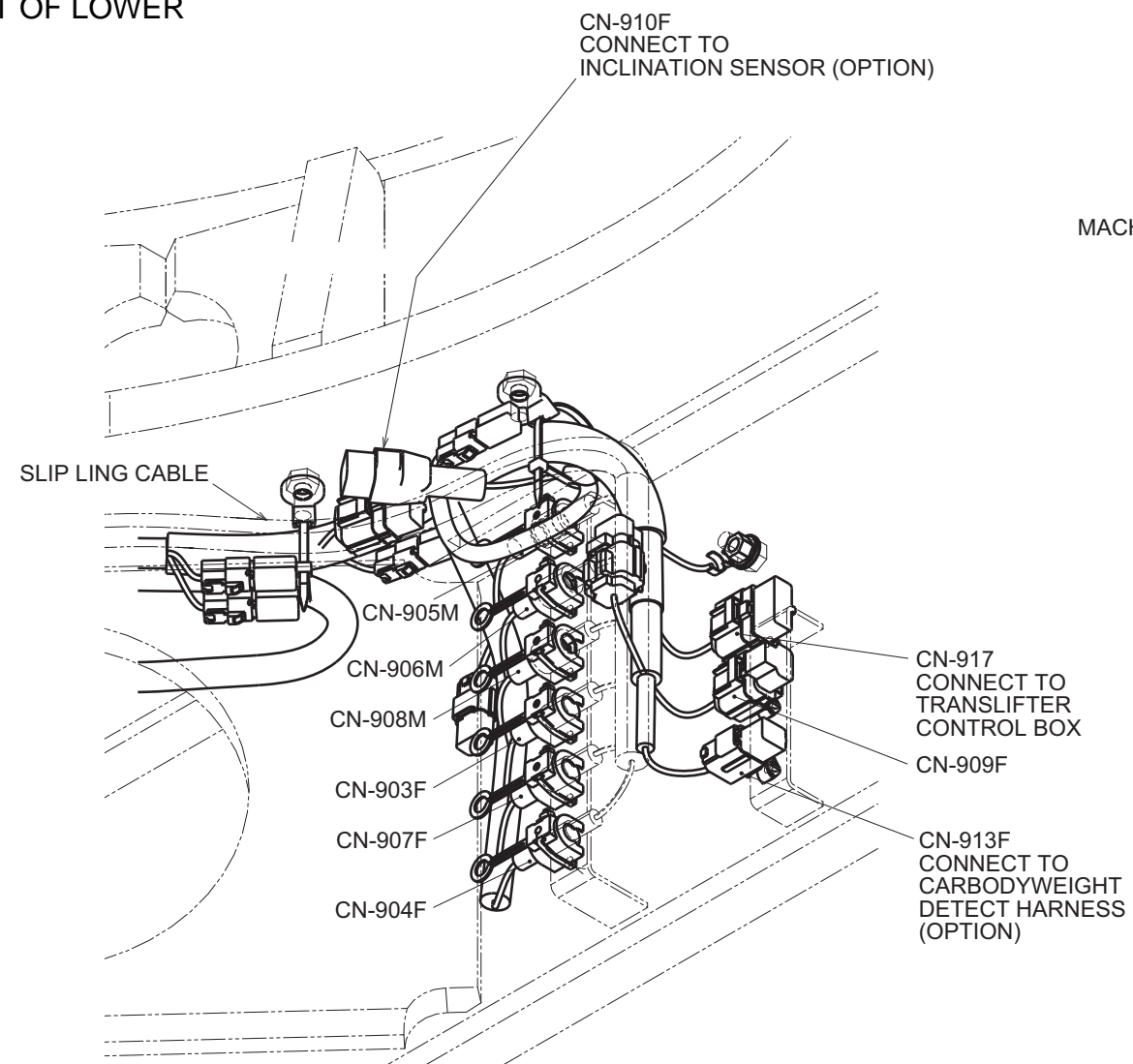

VIEW FROM "A"

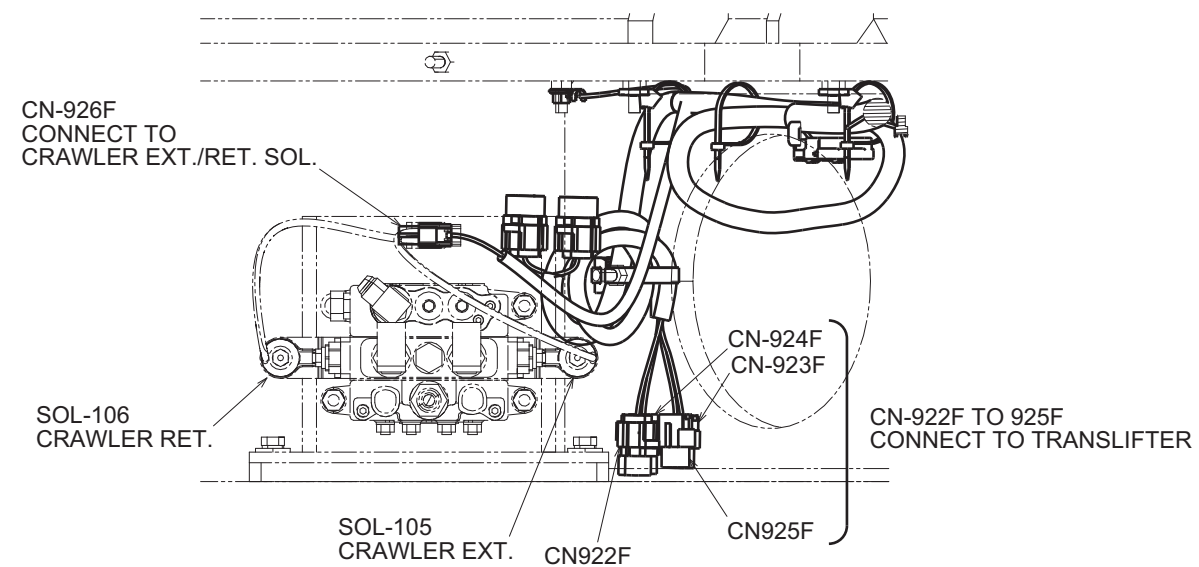

VIEW FROM "B"

SOL : SOLENOID VALVE
SW : SWITCH
PSW : PRESSURE SWITCH
ATT : ATTACHMENT
CW : COUNTER WEIGHT
CB/W : CARBODY WEIGHT

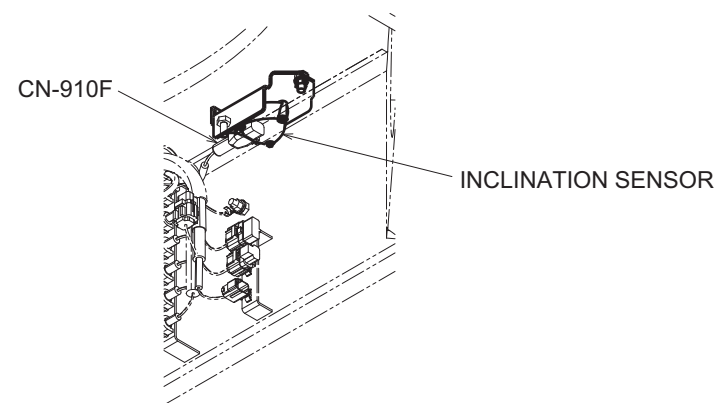
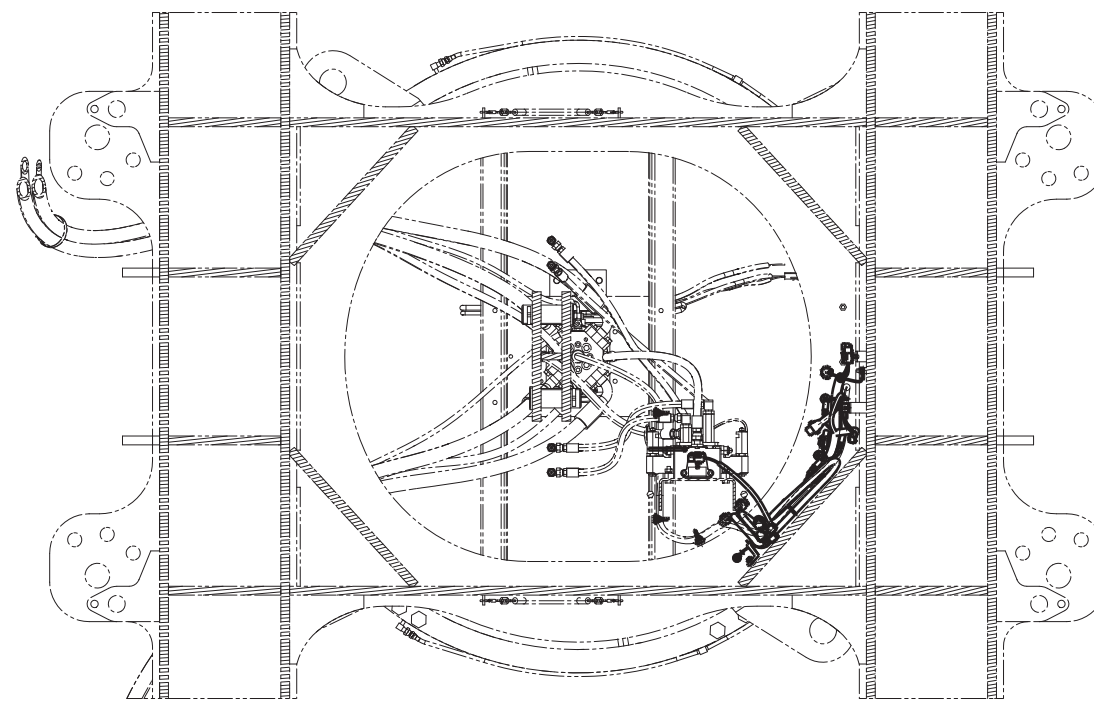
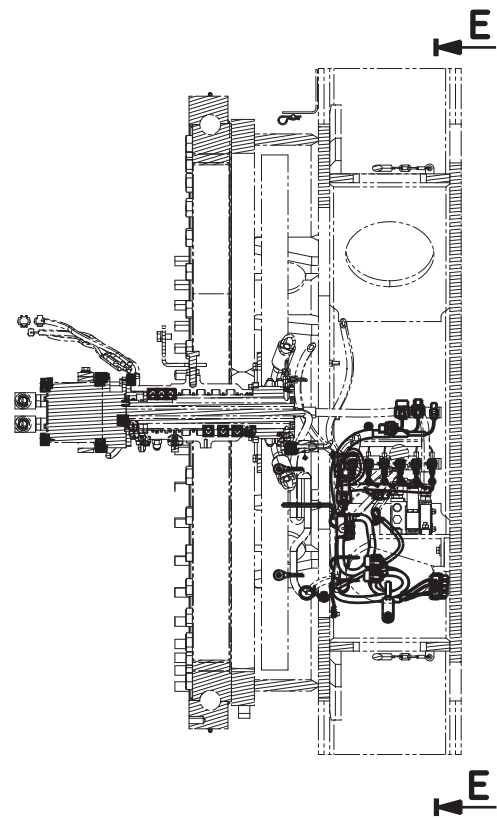

DETAIL OF SENSOR INSTALL

LOWER HARNESS

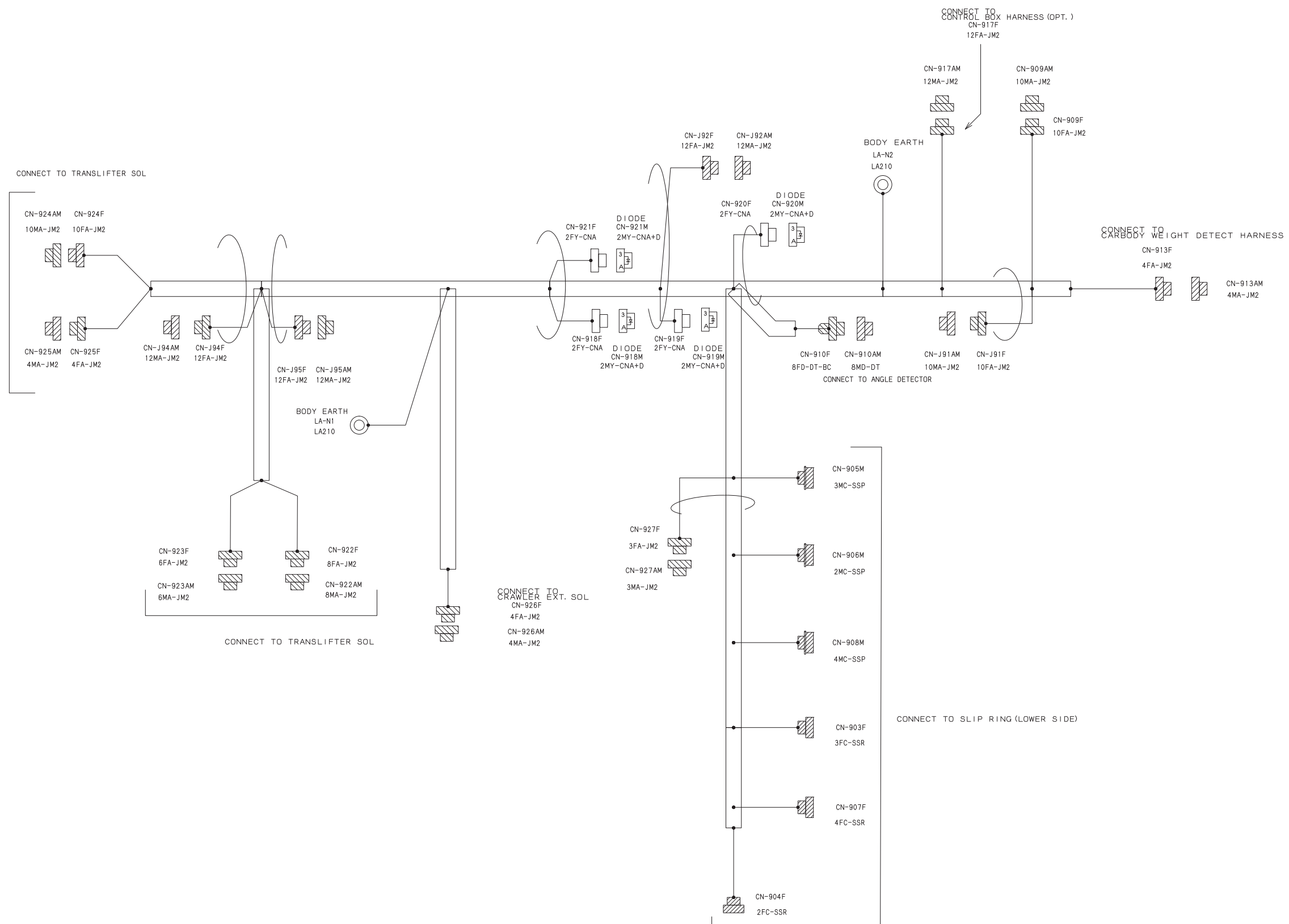

10. ELECTRIC SYSTEM

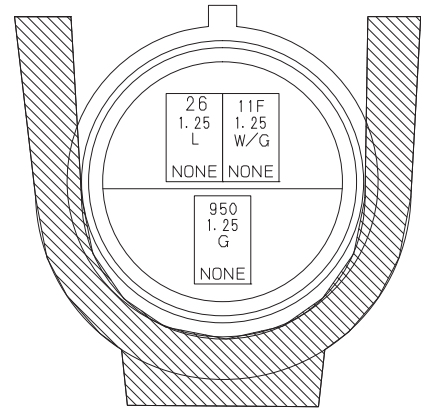

CN-903F
3FC-SSR

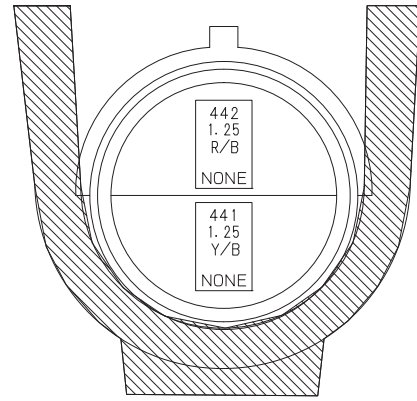

CN-906M
2MC-SSP

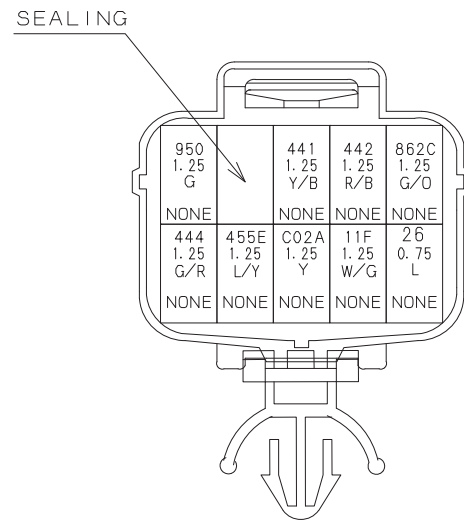

CN-909F
10FA-JM2

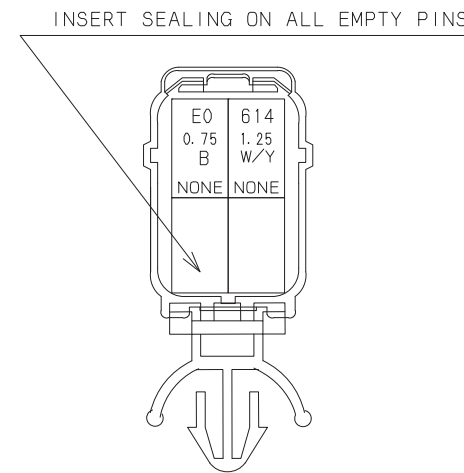

CN-913F
4FA-JM2

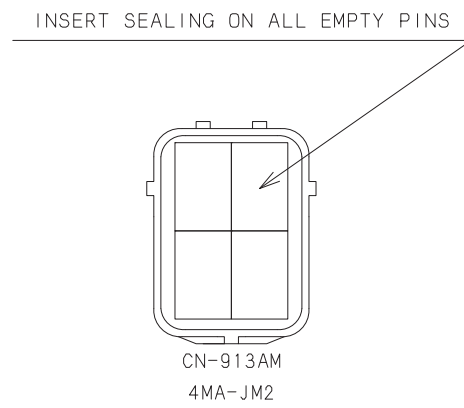

CN-913AM
4MA-JM2

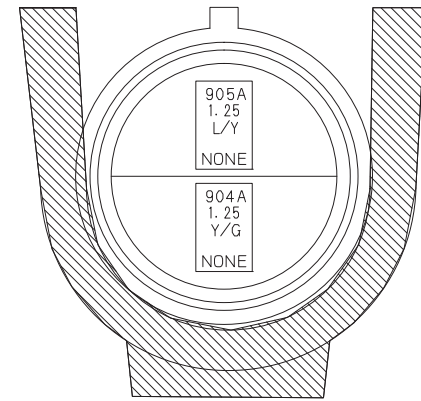

CN-904F
2FC-SSR

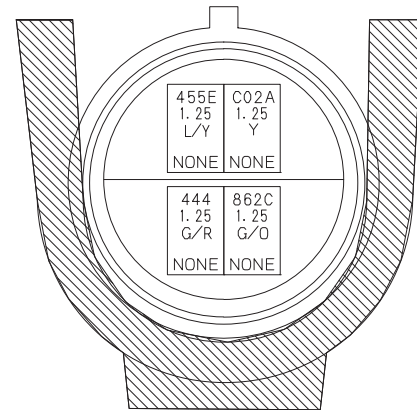

CN-907F
4FC-SSR

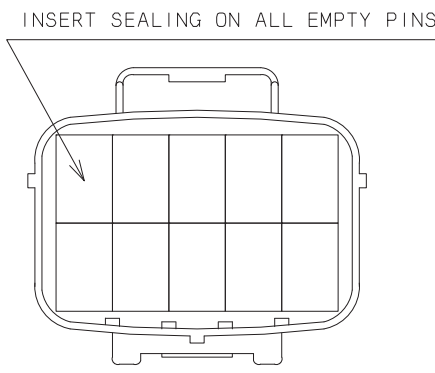

CN-909AM
10MA-JM2

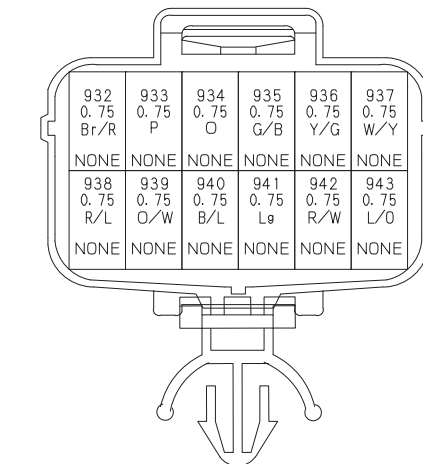

CN-917F
12FA-JM2

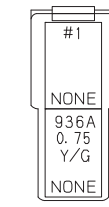

CN-918F
2FY-CNA

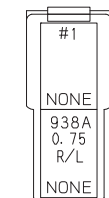

CN-920F
2FY-CNA

#1 905A 1.25 L/Y + 905C 0.75 L/Y

#1 904A 1.25 Y/G + 904C 0.75 Y/G

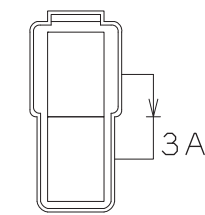

CN-918M
2MY-CNA+D

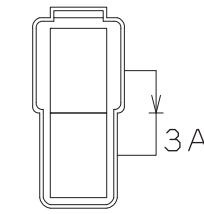

CN-920M
2MY-CNA+D

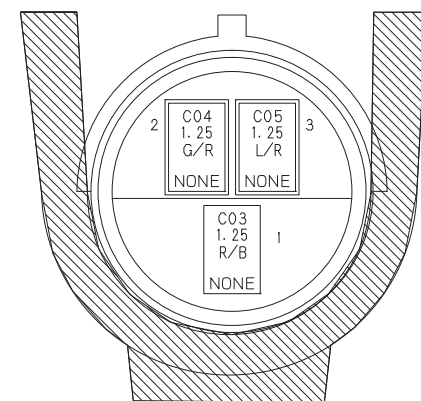

CN-905M
3MC-SSP

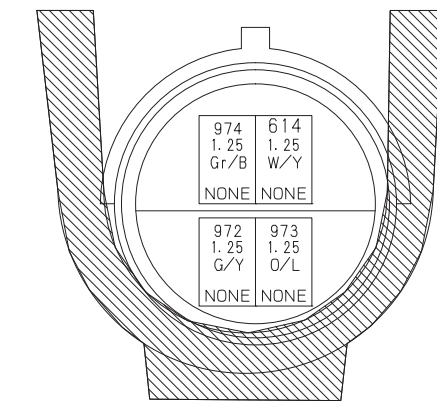

CN-908M
4MC-SSP

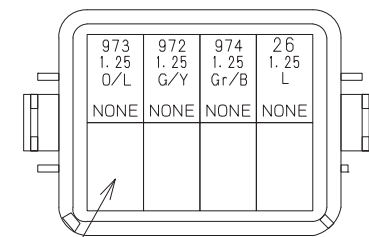

CN-910F
8FD-DT-BC

INSERT SEALING ON ALL EMPTY PINS

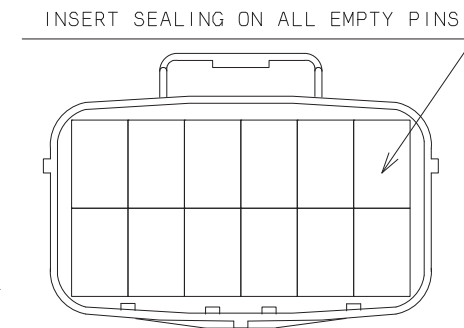

CN-917AM
12MA-JM2

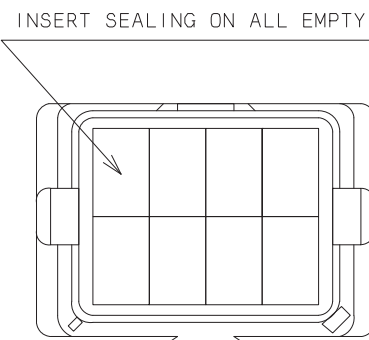

CN-910AM
8MD-DT

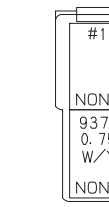

CN-919F
2FY-CNA
#1 905C 0.75 L/Y + 905E 0.75 L/Y

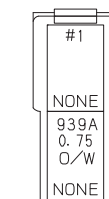

CN-921F
2FY-CNA
#1 904C 0.75 Y/G + 904E 0.75 Y/G

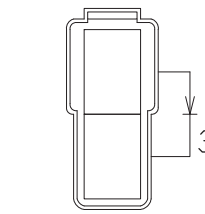

CN-919M
2MY-CNA+D

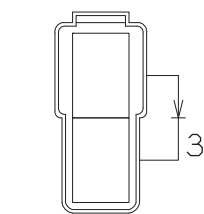

CN-921M
2MY-CNA+D

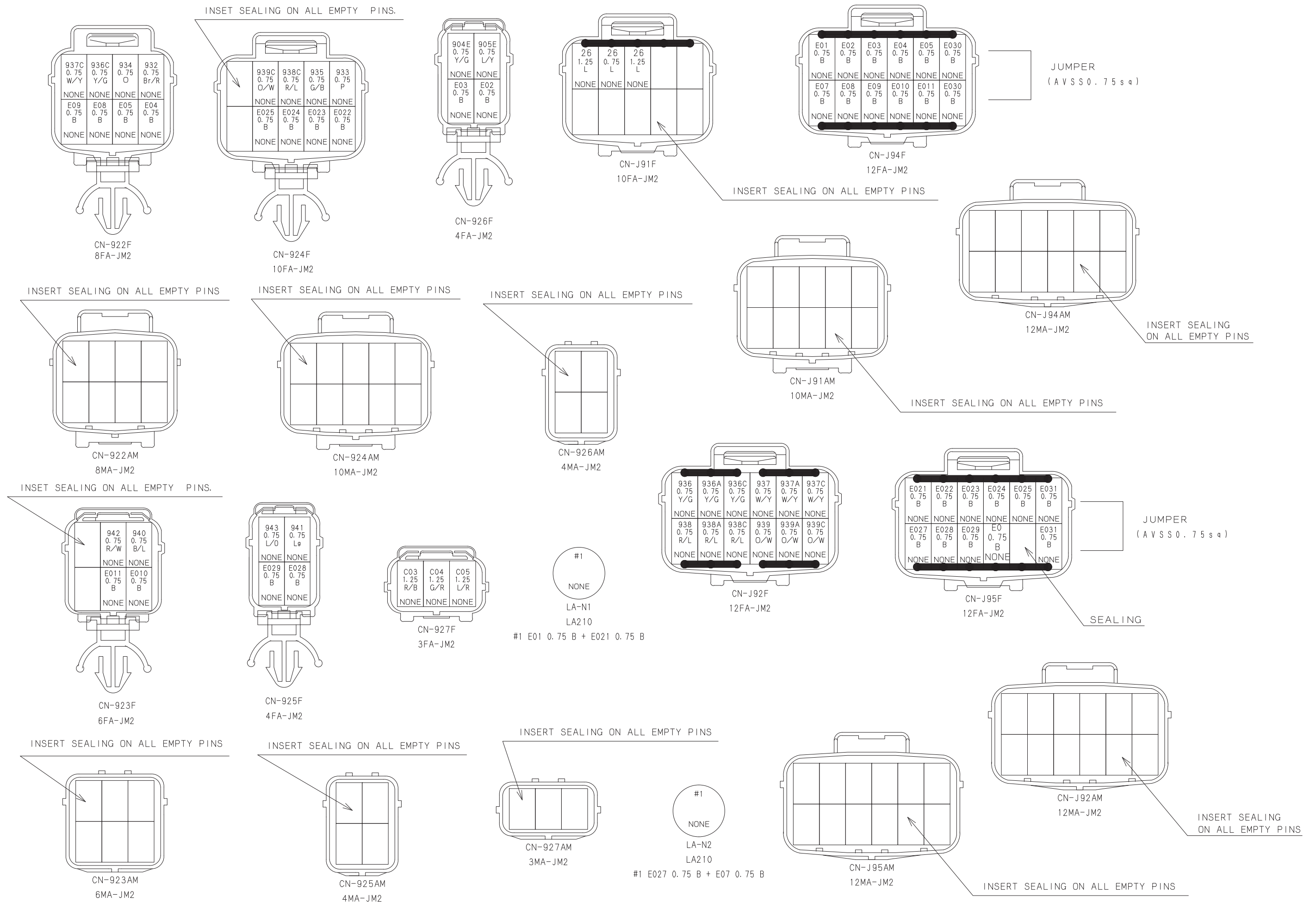

10. ELECTRIC SYSTEM

WIRE No. AND WIRE COLOR LIST

No.	COLOR	TYPE	SIZE	FROM	2-WIRE CLAMP No.	CONNECTION	2-WIRE CLAMP No.	TO
11F	W/G	AVSS	1.25	CN-909F				CN-903F
26A	L	AVSS	1.25	CN-J91F				CN-903F
26C	L	AVSS	1.25	CN-J91F				CN-910F
26G	L	AVSS	0.75	CN-J91F				CN-909F
441	Y/B	AVSS	1.25	CN-906M				CN-909F
442	R/B	AVSS	1.25	CN-906M				CN-909F
444	G/R	AVSS	1.25	CN-907F				CN-909F
455E	L/Y	AVSS	1.25	CN-907F				CN-909F
614	W/Y	AVSS	1.25	CN-913F				CN-908M
862C	G/O	AVSS	1.25	CN-907F				CN-909F
904A	Y/G	AVSS	1.25	CN-904F			DS3	CN-920F
904C	Y/G	AVSS	0.75	CN-921F	DS4		DS3	CN-920F
904E	Y/G	AVSS	0.75	CN-921F	DS4			CN-926F
905A	L/Y	AVSS	1.25	CN-904F			DS1	CN-918F
905C	L/Y	AVSS	0.75	CN-919F	DS2		DS1	CN-918F
905E	L/Y	AVSS	0.75	CN-919F	DS2			CN-926F
932	Br/R	AVSS	0.75	CN-917F				CN-922F
933	P	AVSS	0.75	CN-917F				CN-924F
934	O	AVSS	0.75	CN-917F				CN-922F
935	G/B	AVSS	0.75	CN-917F				CN-924F
936	Y/G	AVSS	0.75	CN-J92F				CN-917F
936A	Y/G	AVSS	0.75	CN-J92F				CN-918F
936C	Y/G	AVSS	0.75	CN-J92F				CN-922F
937	W/Y	AVSS	0.75	CN-J92F				CN-917F
937A	W/Y	AVSS	0.75	CN-J92F				CN-919F
937C	W/Y	AVSS	0.75	CN-J92F				CN-922F
938	R/L	AVSS	0.75	CN-J92F				CN-917F
938A	R/L	AVSS	0.75	CN-J92F				CN-920F
938C	R/L	AVSS	0.75	CN-J92F				CN-924F
939	O/W	AVSS	0.75	CN-J92F				CN-917F
939A	O/W	AVSS	0.75	CN-J92F				CN-921F
939C	O/W	AVSS	0.75	CN-J92F				CN-924F
940	B/L	AVSS	0.75	CN-917F				CN-923F
941	Lg	AVSS	0.75	CN-917F				CN-925F
942	R/W	AVSS	0.75	CN-917F				CN-923F
943	L/O	AVSS	0.75	CN-917F				CN-925F
950	G	AVSS	1.25	CN-909F				CN-903F
972	G/Y	AVSS	1.25	CN-910F				CN-908M
973	O/L	AVSS	1.25	CN-910F				CN-908M
974	Gr/B	AVSS	1.25	CN-910F				CN-908M
C02A	Y	AVSS	1.25	CN-907F				CN-909F
C03	R/B	AVSS	1.25	CN-905M				CN-927F
C04	G/R	AVSS	1.25	CN-905M				CN-927F
C05	L/R	AVSS	1.25	CN-905M				CN-927F
E01	B	AVSS	0.75	CN-J94F			DS5	LA-N1
E02	B	AVSS	0.75	CN-J94F				CN-926F
E03	B	AVSS	0.75	CN-J94F				CN-926F
E04	B	AVSS	0.75	CN-J94F				CN-922F
E05	B	AVSS	0.75	CN-J94F				CN-922F
E030	B	AVSS	0.75	CN-J94F				CN-J94F
E07	B	AVSS	0.75	LA-N2	DS6			CN-J94F
E08	B	AVSS	0.75	CN-922F				CN-J94F
E09	B	AVSS	0.75	CN-922F				CN-J94F
E010	B	AVSS	0.75	CN-923F				CN-J94F
E011	B	AVSS	0.75	CN-923F				CN-J94F
E021	B	AVSS	0.75	CN-J95F			DS5	LA-N1
E022	B	AVSS	0.75	CN-J95F				CN-924F
E023	B	AVSS	0.75	CN-J95F				CN-924F
E024	B	AVSS	0.75	CN-J95F				CN-924F
E025	B	AVSS	0.75	CN-J95F				CN-924F
E031	B	AVSS	0.75	CN-J95F				CN-J95F
E027	B	AVSS	0.75	LA-N2	DS6			CN-J95F
E028	B	AVSS	0.75	CN-925F				CN-J95F
E029	B	AVSS	0.75	CN-925F				CN-J95F
E0	B	AVSS	0.75	CN-913F				CN-J95F

TRANS LIFTER REMOTE CONTROLLER CABLE HARNESS (OPTION)



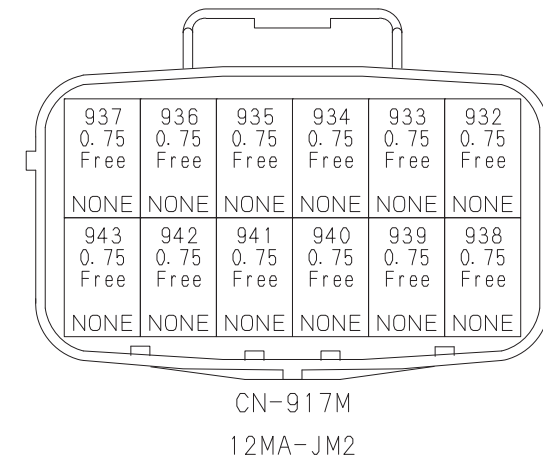
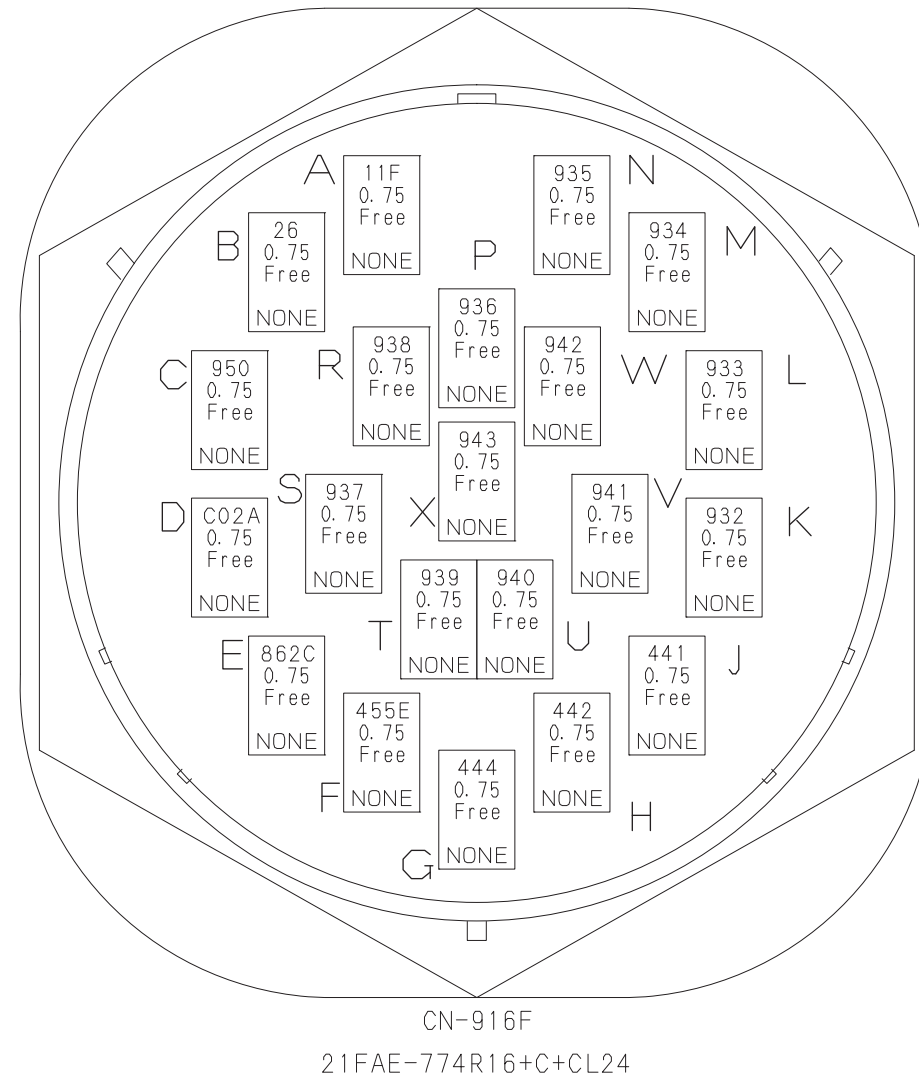
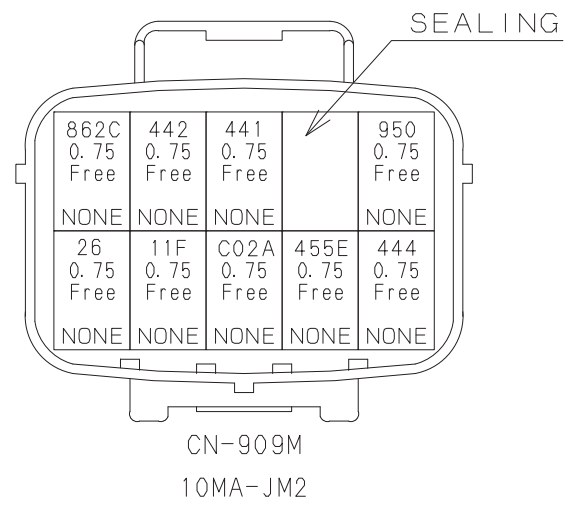

WIRE No. AND WIRE COLOR LIST

No.	COLOR	TYPE	SIZE	FROM	2-WIRE CLAMP No.	CONNECTION	2-WIRE CLAMP No.	TO
11F	Free	2PNCT-SR	0.75	CN-909M		_____		CN-916F
26	Free	2PNCT-SR	0.75	CN-909M		_____		CN-916F
441	Free	2PNCT-SR	0.75	CN-909M		_____		CN-916F
442	Free	2PNCT-SR	0.75	CN-909M		_____		CN-916F
444	Free	2PNCT-SR	0.75	CN-909M		_____		CN-916F
455E	Free	2PNCT-SR	0.75	CN-909M		_____		CN-916F
862C	Free	2PNCT-SR	0.75	CN-909M		_____		CN-916F
932	Free	2PNCT-SR	0.75	CN-917M		_____		CN-916F
933	Free	2PNCT-SR	0.75	CN-917M		_____		CN-916F
934	Free	2PNCT-SR	0.75	CN-917M		_____		CN-916F
935	Free	2PNCT-SR	0.75	CN-917M		_____		CN-916F
936	Free	2PNCT-SR	0.75	CN-917M		_____		CN-916F
937	Free	2PNCT-SR	0.75	CN-917M		_____		CN-916F
938	Free	2PNCT-SR	0.75	CN-917M		_____		CN-916F
939	Free	2PNCT-SR	0.75	CN-917M		_____		CN-916F
940	Free	2PNCT-SR	0.75	CN-917M		_____		CN-916F
941	Free	2PNCT-SR	0.75	CN-917M		_____		CN-916F
942	Free	2PNCT-SR	0.75	CN-917M		_____		CN-916F
943	Free	2PNCT-SR	0.75	CN-917M		_____		CN-916F
950	Free	2PNCT-SR	0.75	CN-909M		_____		CN-916F
C02A	Free	2PNCT-SR	0.75	CN-909M		_____		CN-916F



10. ELECTRIC SYSTEM

3. ELECTRICAL PART OF LEFT DECK

SOL : SOLENOID VALVE
 SW : SWITCH
 PSW : PRESSURE SWITCH
 ATT. : ATTACHMENT
 C/W : COUNTER WEIGHT
 CB/W : CARBODY WEIGHT

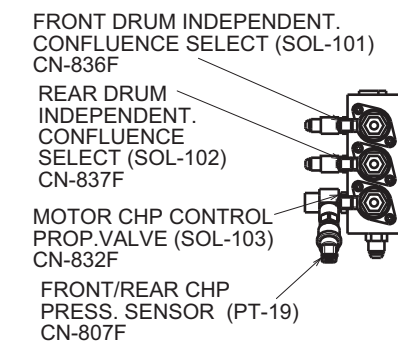
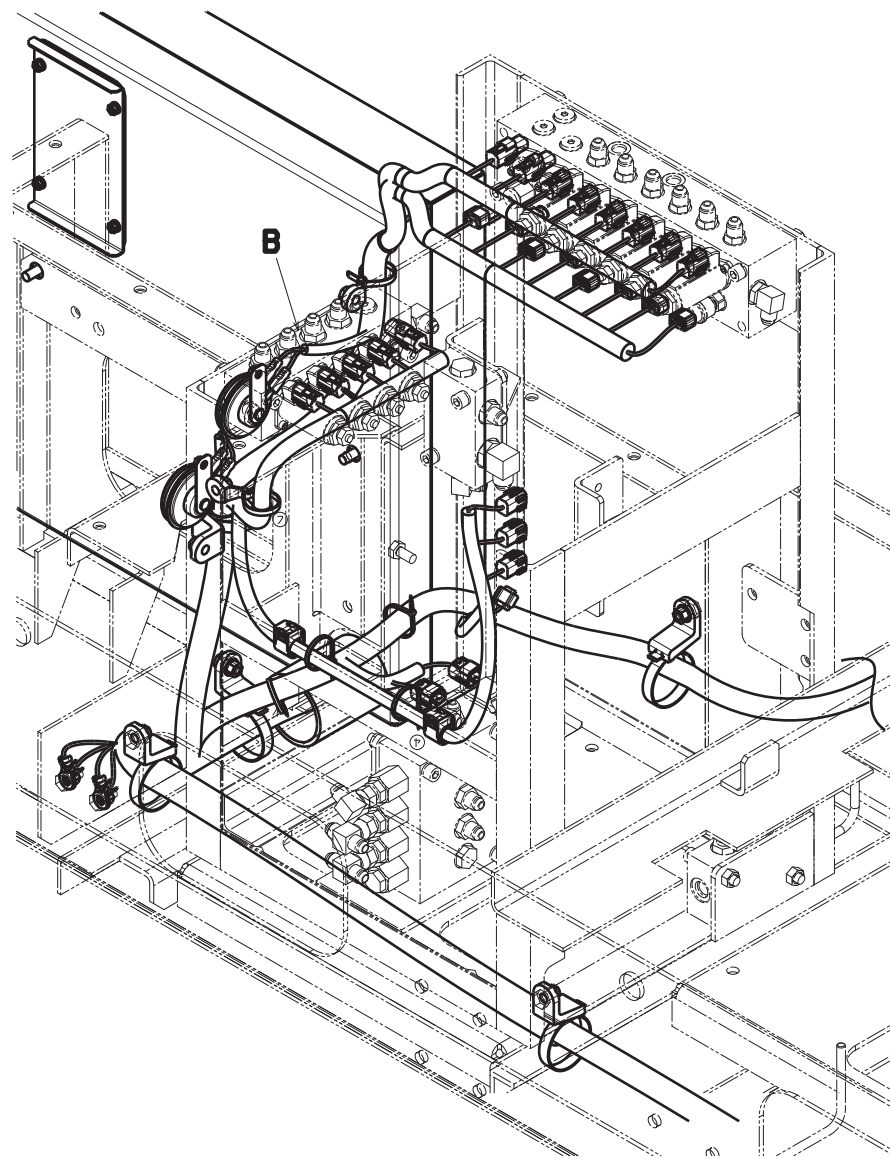
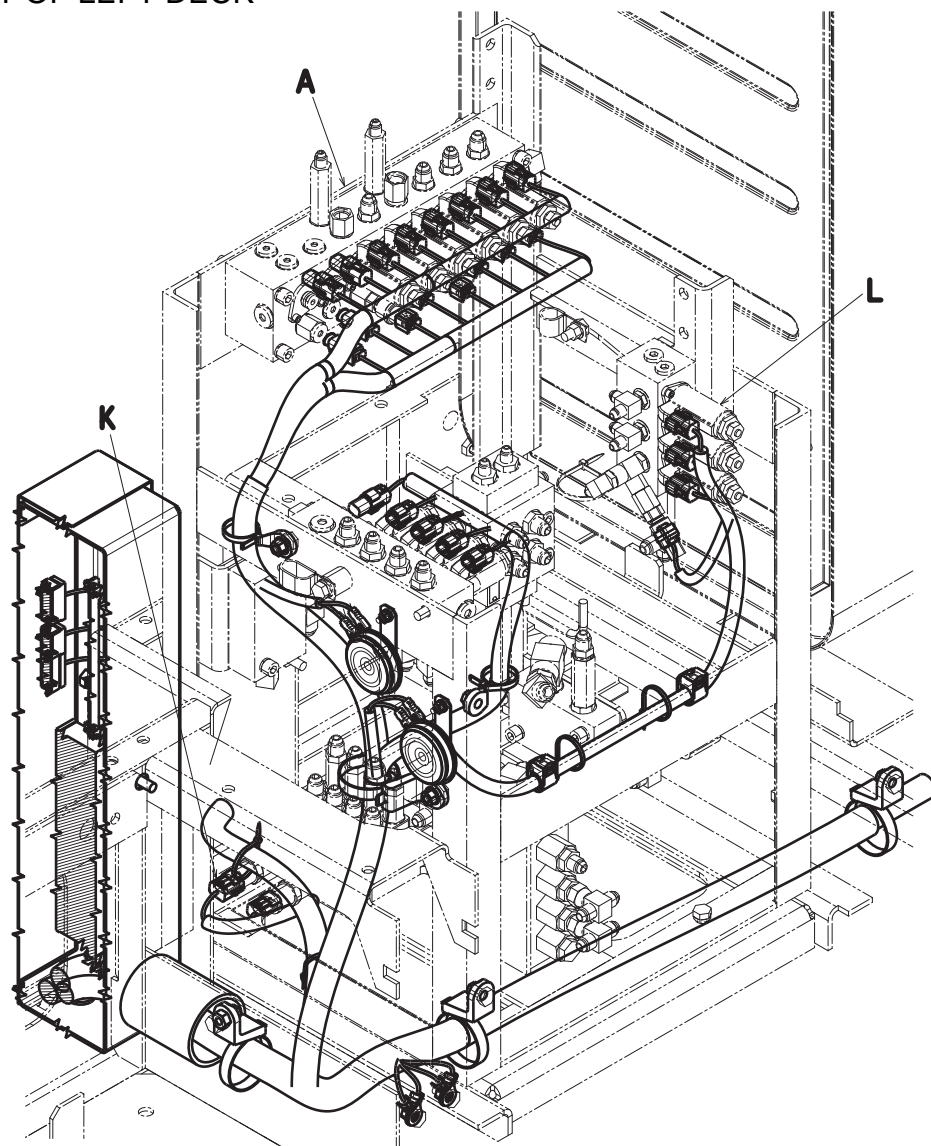

DETAIL OF "L"
 FOR 12000-1/12000E-1

REAR DRUM RAISE REMO-CON. PROP.VALVE (SOL-56)
 CN-828F
 REAR DRUM LOWER REMO-CON. PROP.VALVE (SOL-57)
 CN-829F
 FRONT DRUM RAISE REMO-CON. PROP.VALVE (SOL-54)
 CN-826F
 FRONT DRUM LOWER REMO-CON. PROP.VALVE (SOL-55)
 CN-827F
 THIRD DRUM RAISE REMO-CON. PROP VALVE (SOL-58) OPTION
 CN-830F
 THIRD DRUM LOWER REMO-CON. PROP VALVE (SOL-59) OPTION
 CN-831F

BOOM LOWERING
 REMO-CON. PROP. VALVE (SOL-53)
 CN-825F

BOOM RAISE
 REMO-CON. PROP. VALVE (SOL-52)
 CN-824F

BOOM RAISE STOP (SOL-35)
 CN-822F
 BOOM LOWERING STOP (SOL-36)
 CN-823F
 REAR DRUM RAISE STOP (SOL-38)
 CN-821F
 FRONT DRUM RAISE STOP (SOL-37)
 CN-820F
 THIRD RAISE STOP (SOL-18)
 OPTION
 CN-819F

FRONT DRUM INDEPENDENT.
 CONFLUENCE SELECT
 PRESS. SENSOR (PT-17)
 CN-805F

REAR DRUM INDEPENDENT.
 CONFLUENCE SELECT
 PRESS. SENSOR (PT-18)
 CN-806F

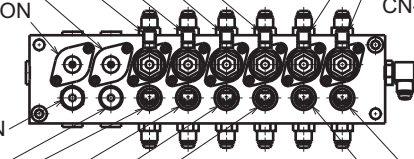

DETAIL OF "A"

THIRD DRUM LOWER PRESS. SENSOR (PT-8) OPTION
 CN-815F
 THIRD DRUM RAISE PRESS. SENSOR (PT-7) OPTION
 CN-814F
 FRONT DRUM LOWER PRESS. SENSOR (PT-4)
 CN-811F
 FRONT DRUM RAISE PRESS. SENSOR (PT-3)
 CN-810F
 REAR DRUM LOWER PRESS. SENSOR (PT-6)
 CN-813F
 REAR DRUM RAISE PRESS. SENSOR (PT-5)
 CN-812F

BOOM RAISE PRESS. SENSOR (PT-12)
 CN-808F
 BOOM LOWER PRESS. SENSOR (PT-13)
 CN-809F

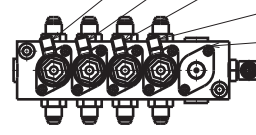

DETAIL OF "B"

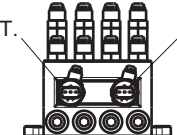

DETAIL OF "K"
 FOR 12000-1/12000E-1

SOL : SOLENOID VALVE
 SW : SWITCH
 PSW : PRESSURE SWITCH
 ATT. : ATTACHMENT
 C/W : COUNTER WEIGHT
 CB/W : CARBODY WEIGHT

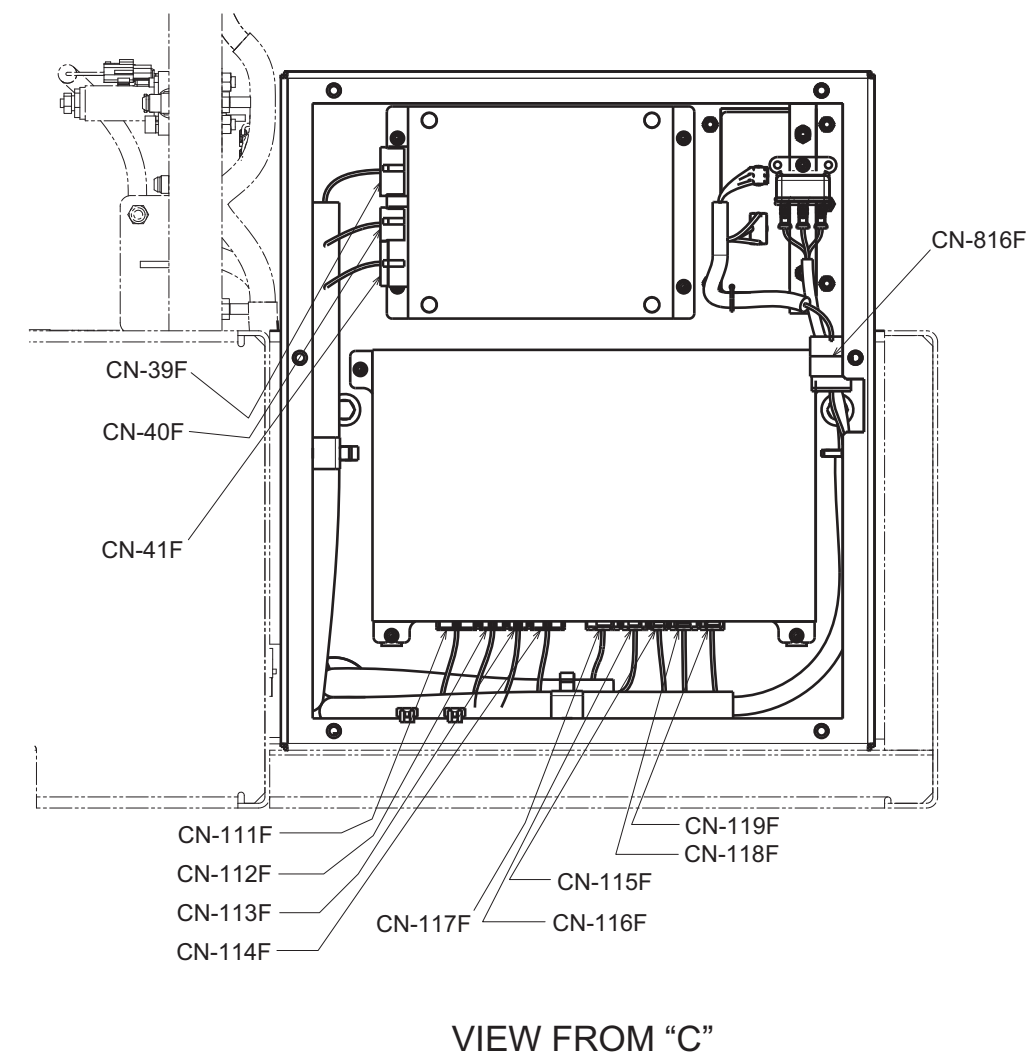
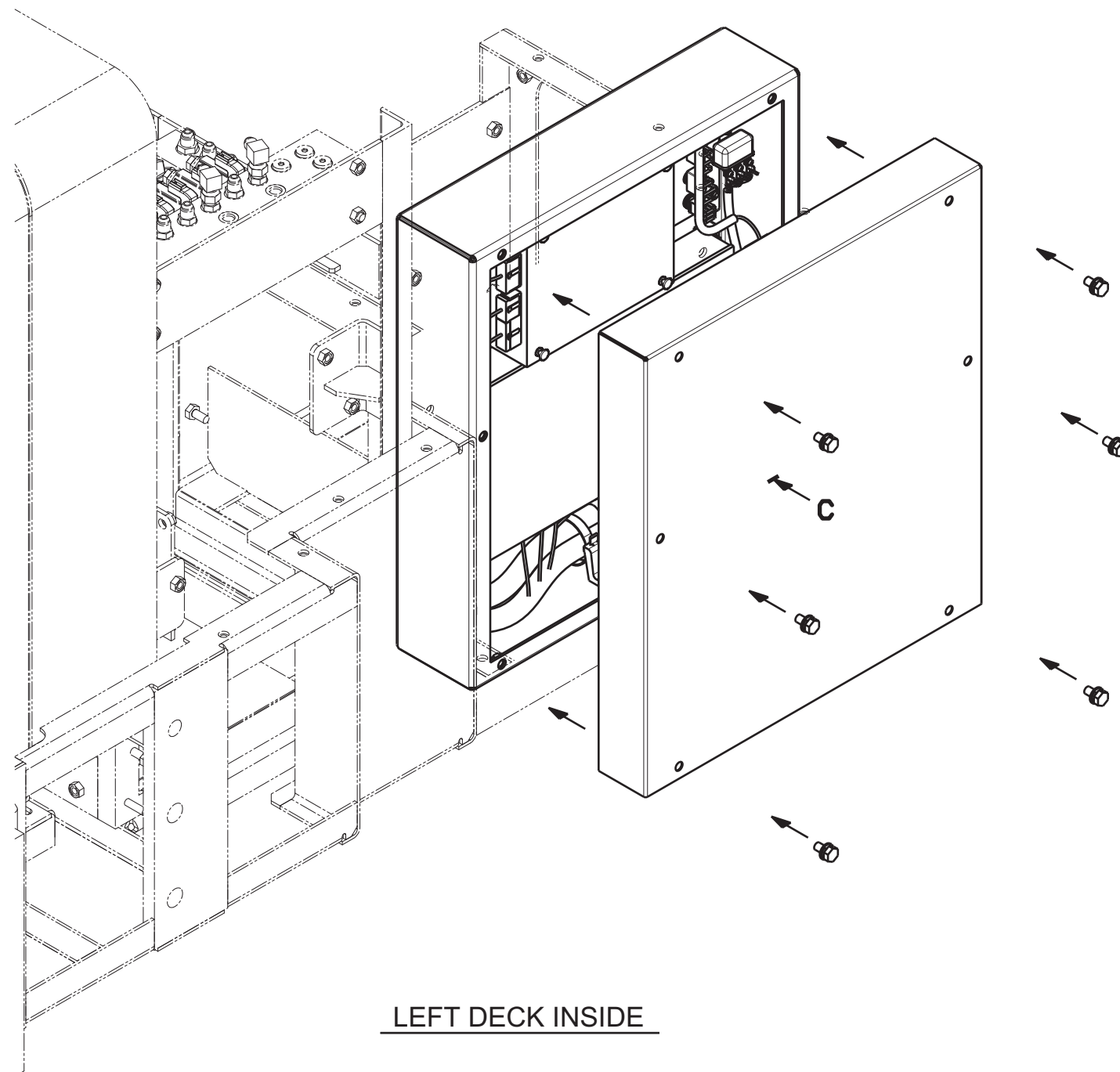

SOL : SOLENOID VALVE
 SW : SWITCH
 PSW : PRESSURE SWITCH
 ATT : ATTACHMENT
 C/W : COUNTER WEIGHT
 CB/W : CARBODY WEIGHT

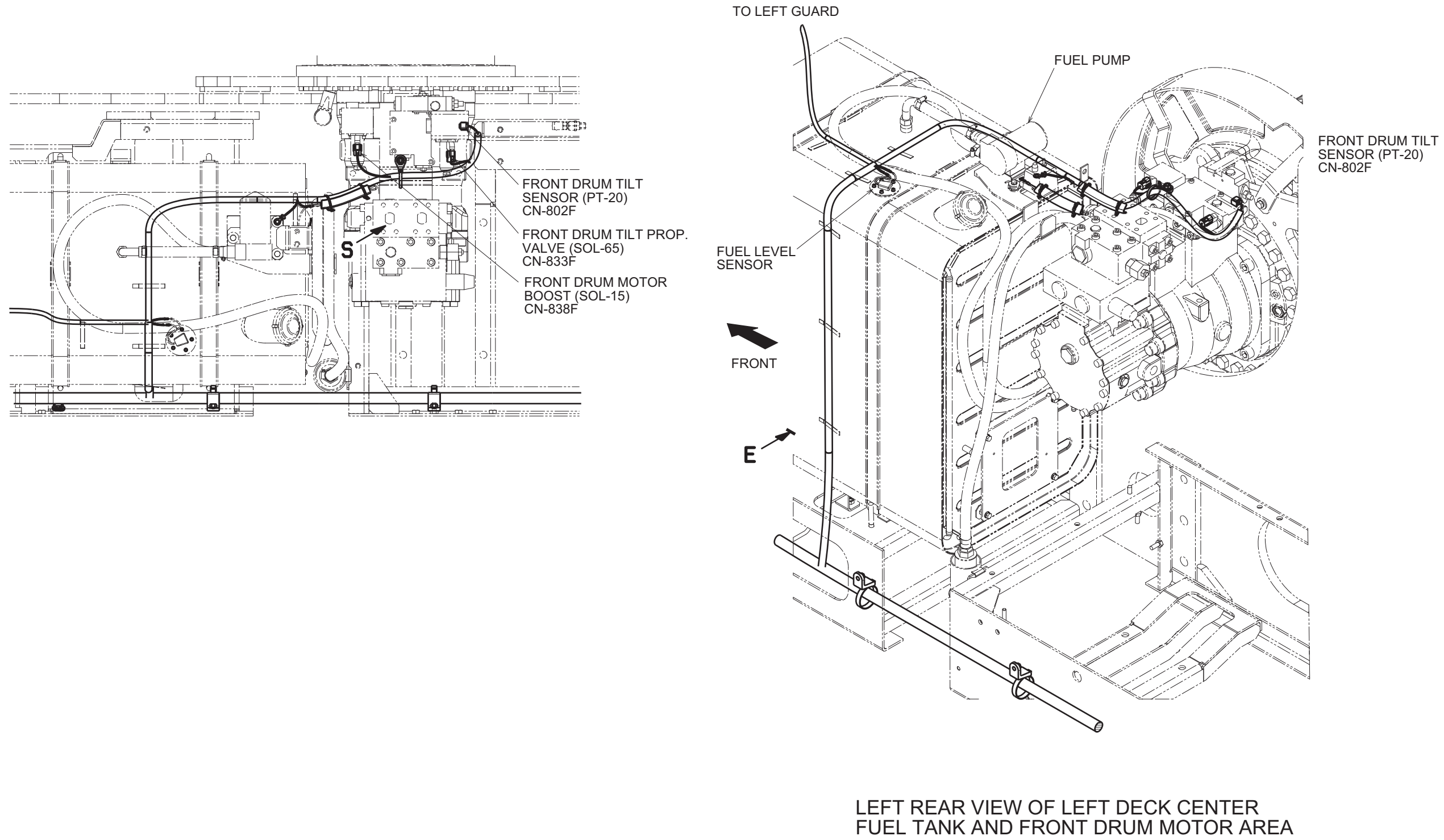

SOL : SOLENOID VALVE
 SW : SWITCH
 PSW : PRESSURE SWITCH
 ATT : ATTACHMENT
 C/W : COUNTER WEIGHT
 CB/W : CARBODY WEIGHT

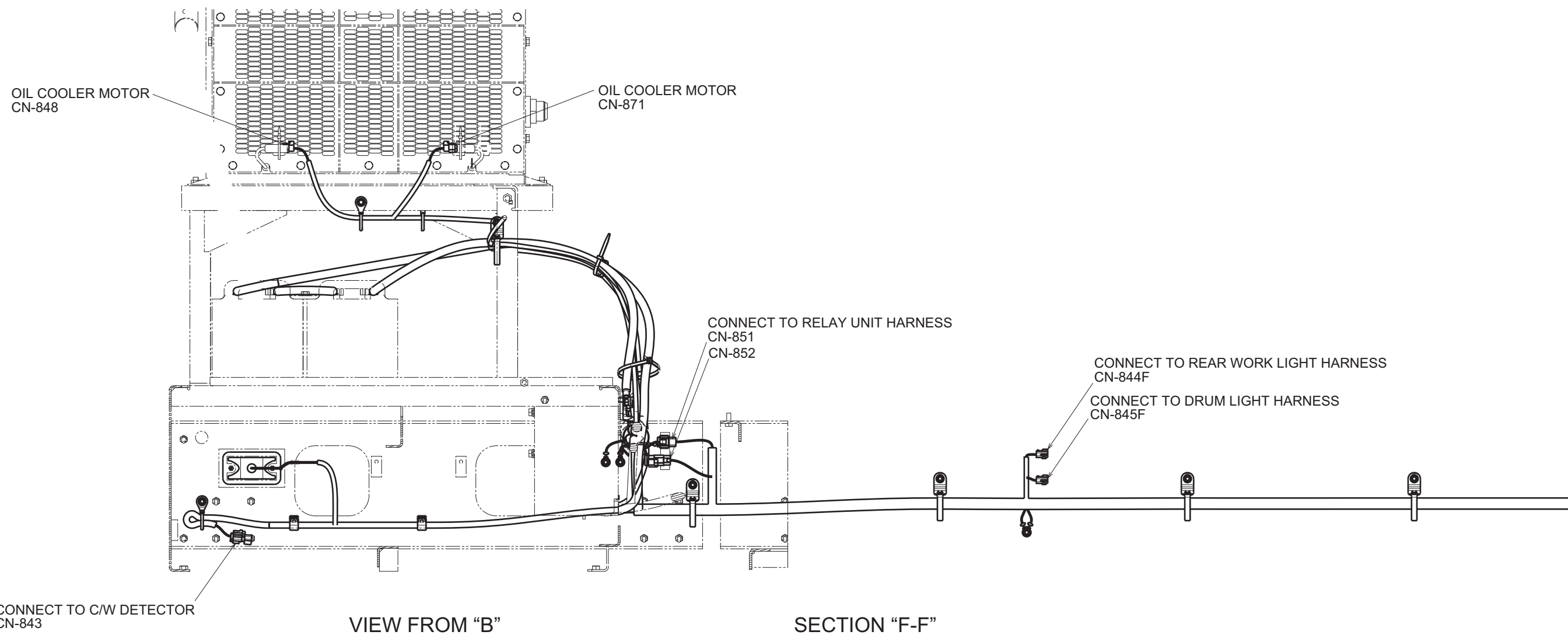
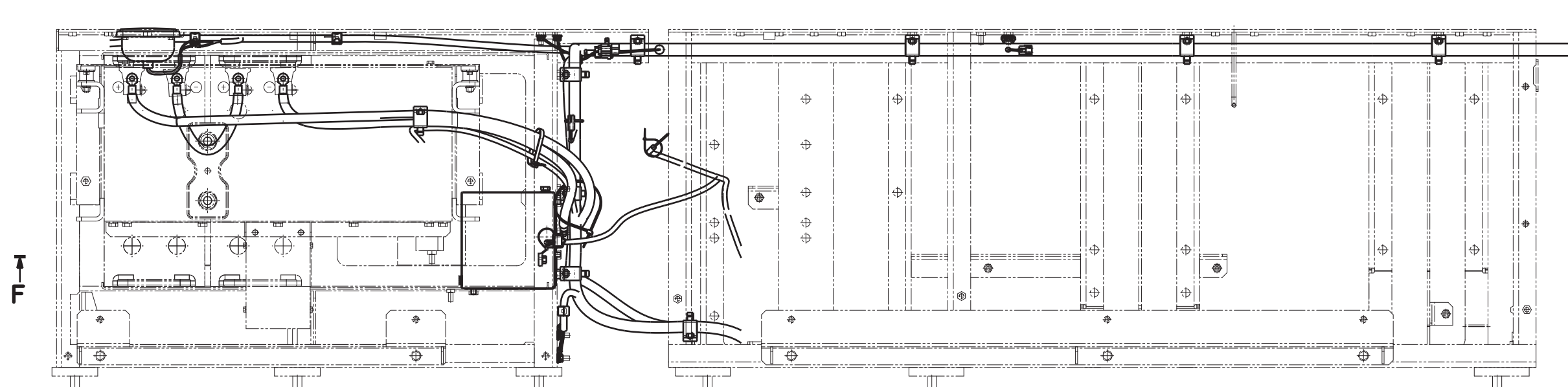

10. ELECTRIC SYSTEM

SOL : SOLENOID VALVE
 SW : SWITCH
 PSW : PRESSURE SWITCH
 ATT. : ATTACHMENT
 CW : COUNTER WEIGHT
 CB/W : CARBODY WEIGHT

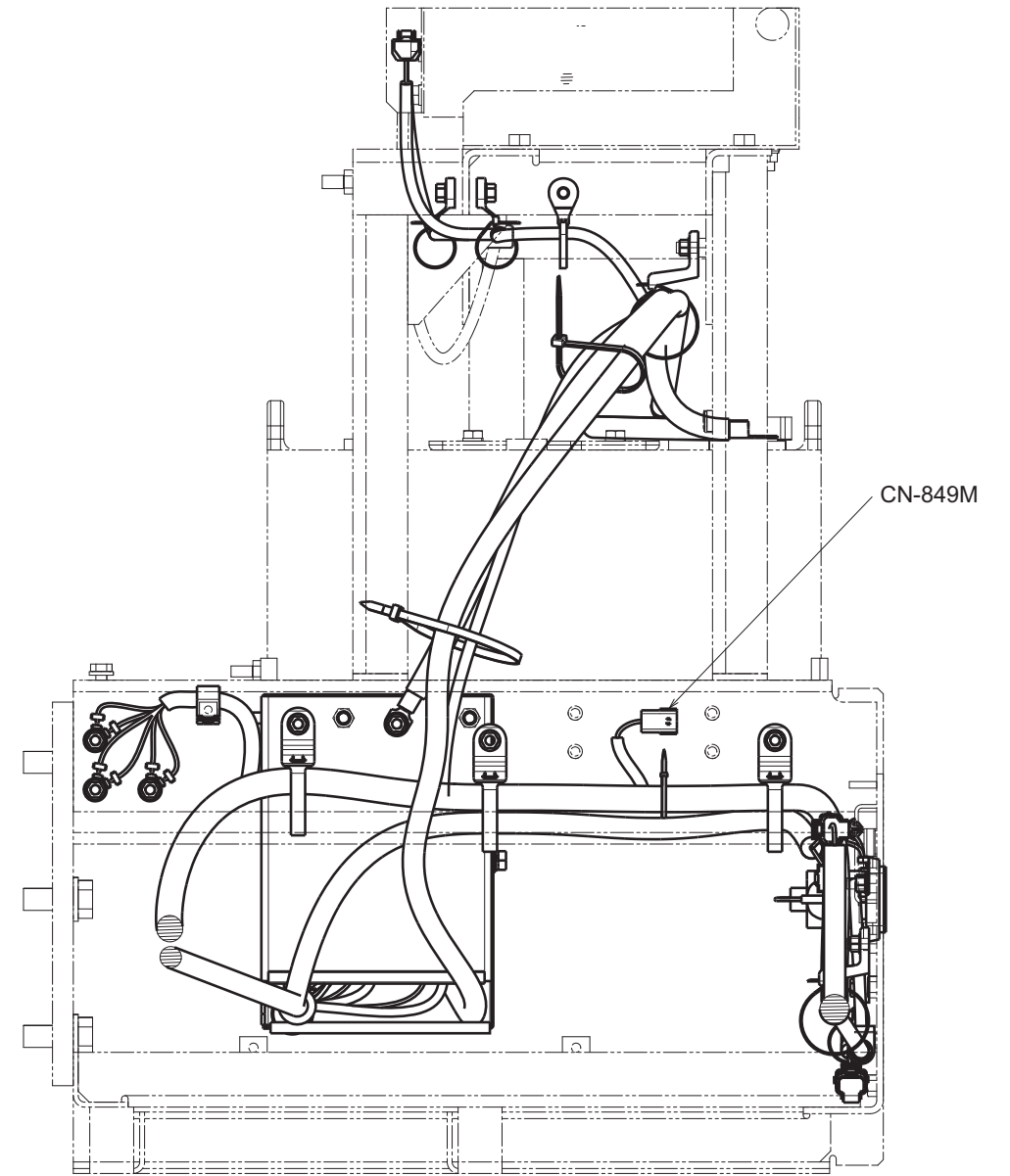
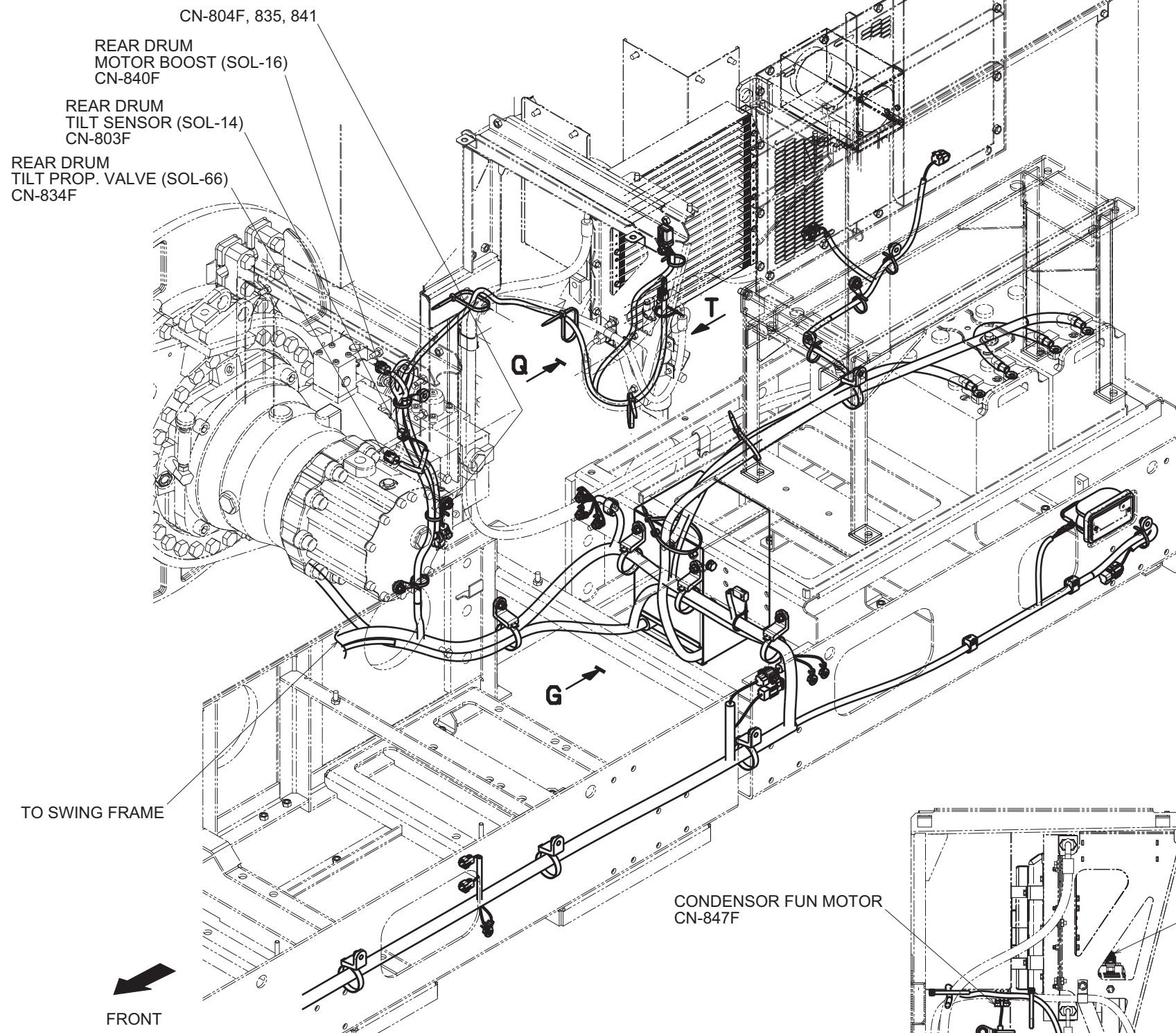

VIEW FROM "G"

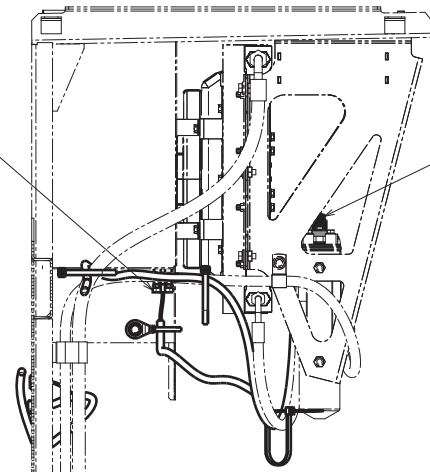

VIEW FROM "Q"

SOL : SOLENOID VALVE
 SW : SWITCH
 PSW : PRESSURE SWITCH
 ATT : ATTACHMENT
 C/W : COUNTER WEIGHT
 CB/W : CARBODY WEIGHT

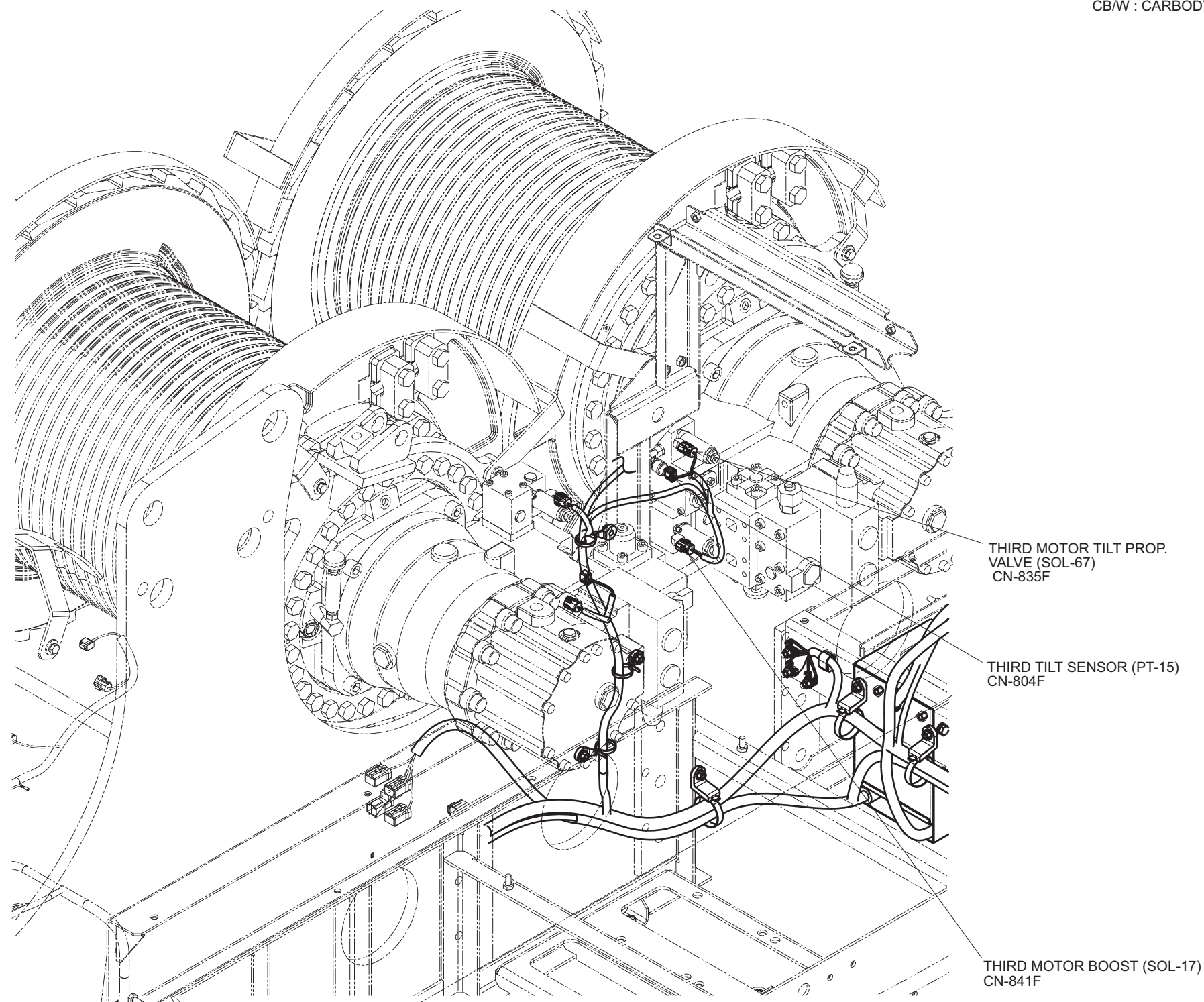
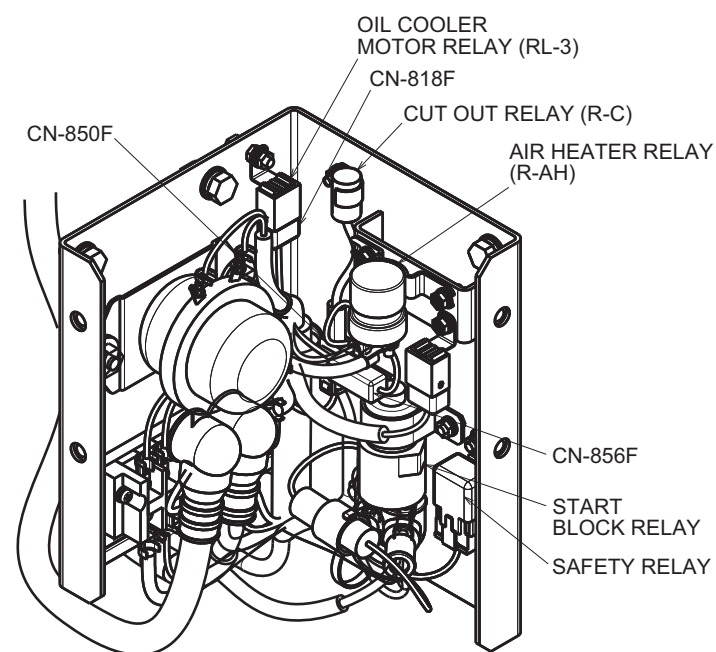
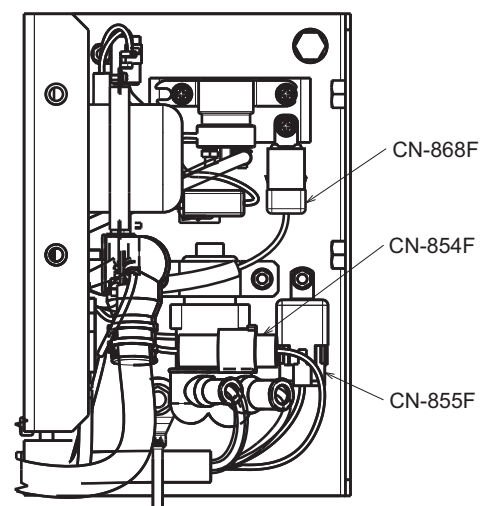

WHEN THIRD WINCH (OPTION) IS INSTALLED.

10. ELECTRIC SYSTEM

LEFT DECK HARNESS

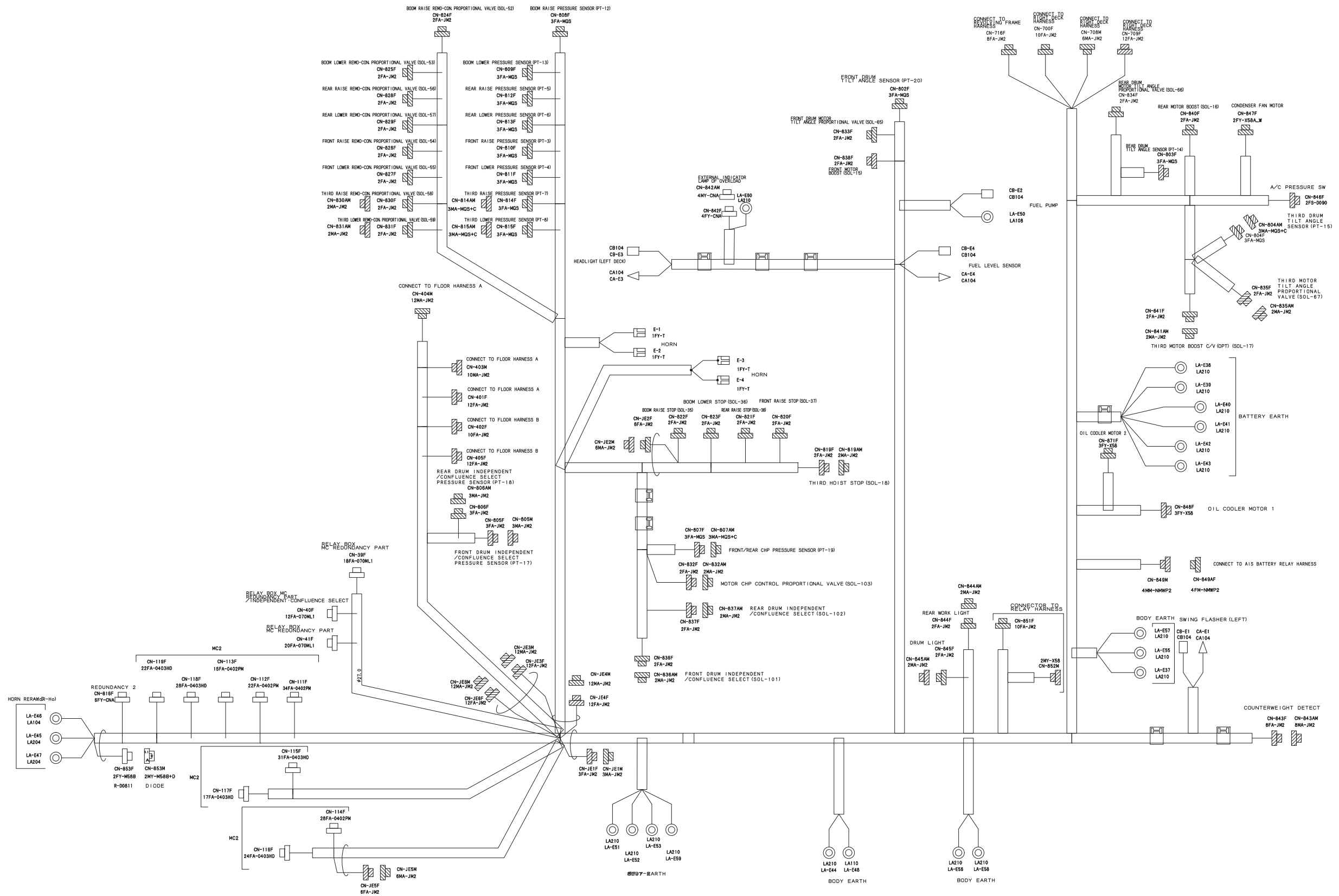

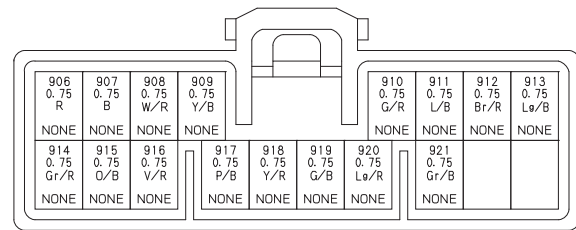

CN-39F
18FA-070ML1

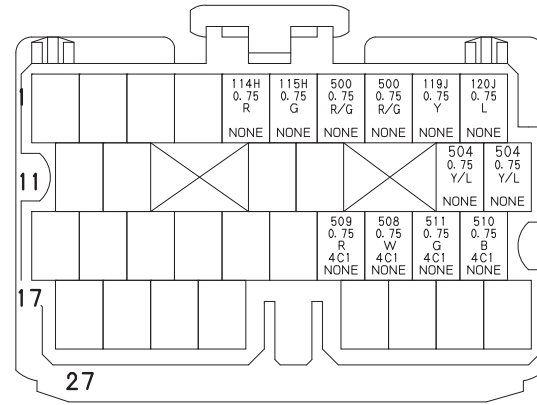

CN-111F
34FA-0402PM

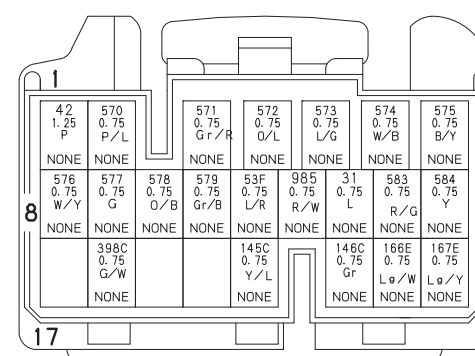

CN-116F
24FA-0403HD

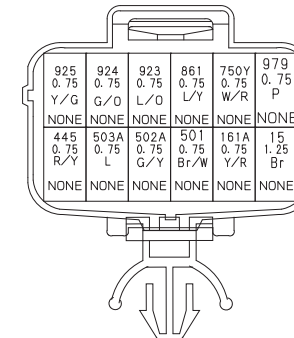

CN-401F
12FA-JM2

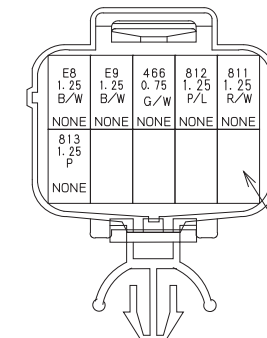

CN-700F
10FA-JM2

INSET SEALING ON ALL EMPTY PINS.

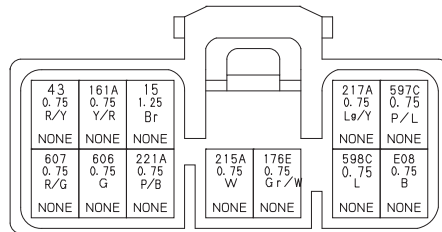

CN-40F
12FA-070ML1

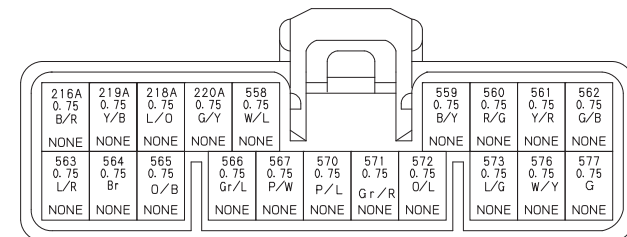

CN-41F
20FA-070ML1

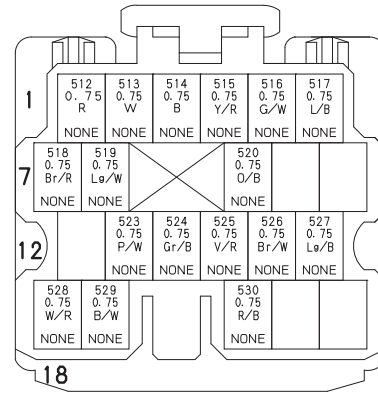

CN-112F
22FA-0402PM

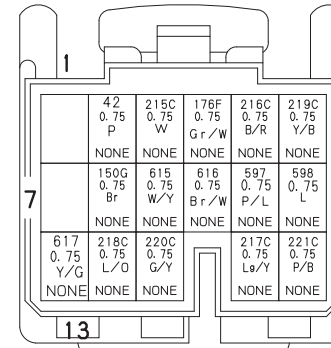

CN-117F
17FA-0403HD

INSET SEALING ON ALL EMPTY PINS.

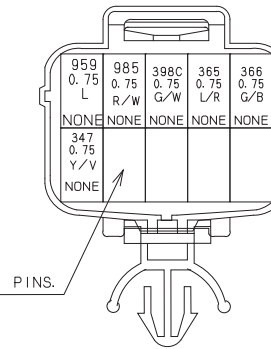

CN-402F
10FA-JM2

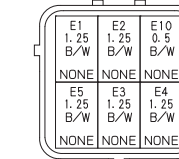

CN-708M
6MA-JM2

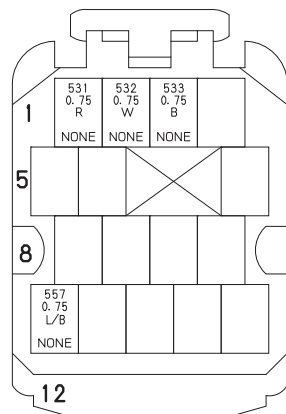

CN-113F
16FA-0402PM

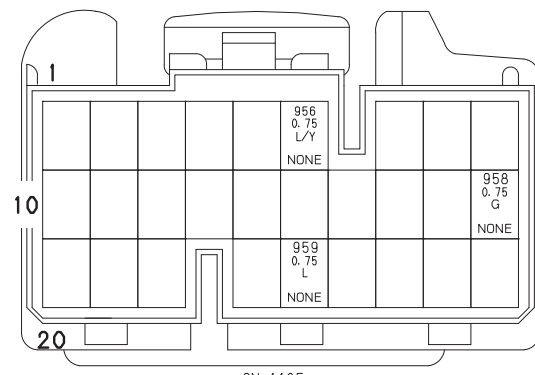

CN-118F
28FA-0403HD

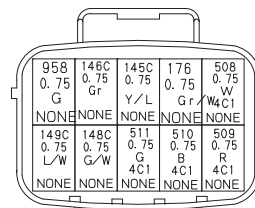

CN-403M
10MA-JM2

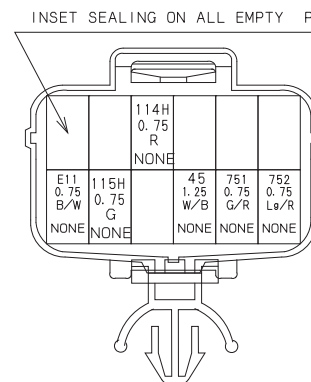

CN-709F
12FA-JM2

INSET SEALING ON ALL EMPTY PINS.

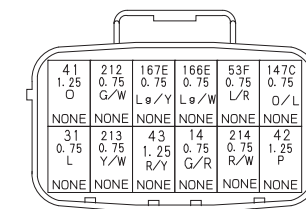

CN-404M
12MA-JM2

INSET SEALING ON ALL EMPTY PINS.

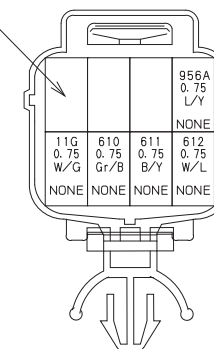

CN-716F
8FA-JM2

INSET SEALING ON ALL EMPTY PINS.

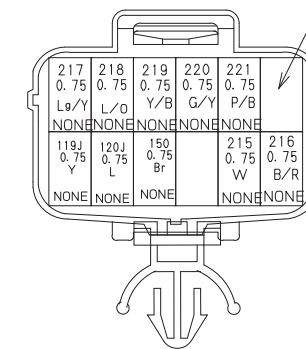

CN-405F
12FA-JM2

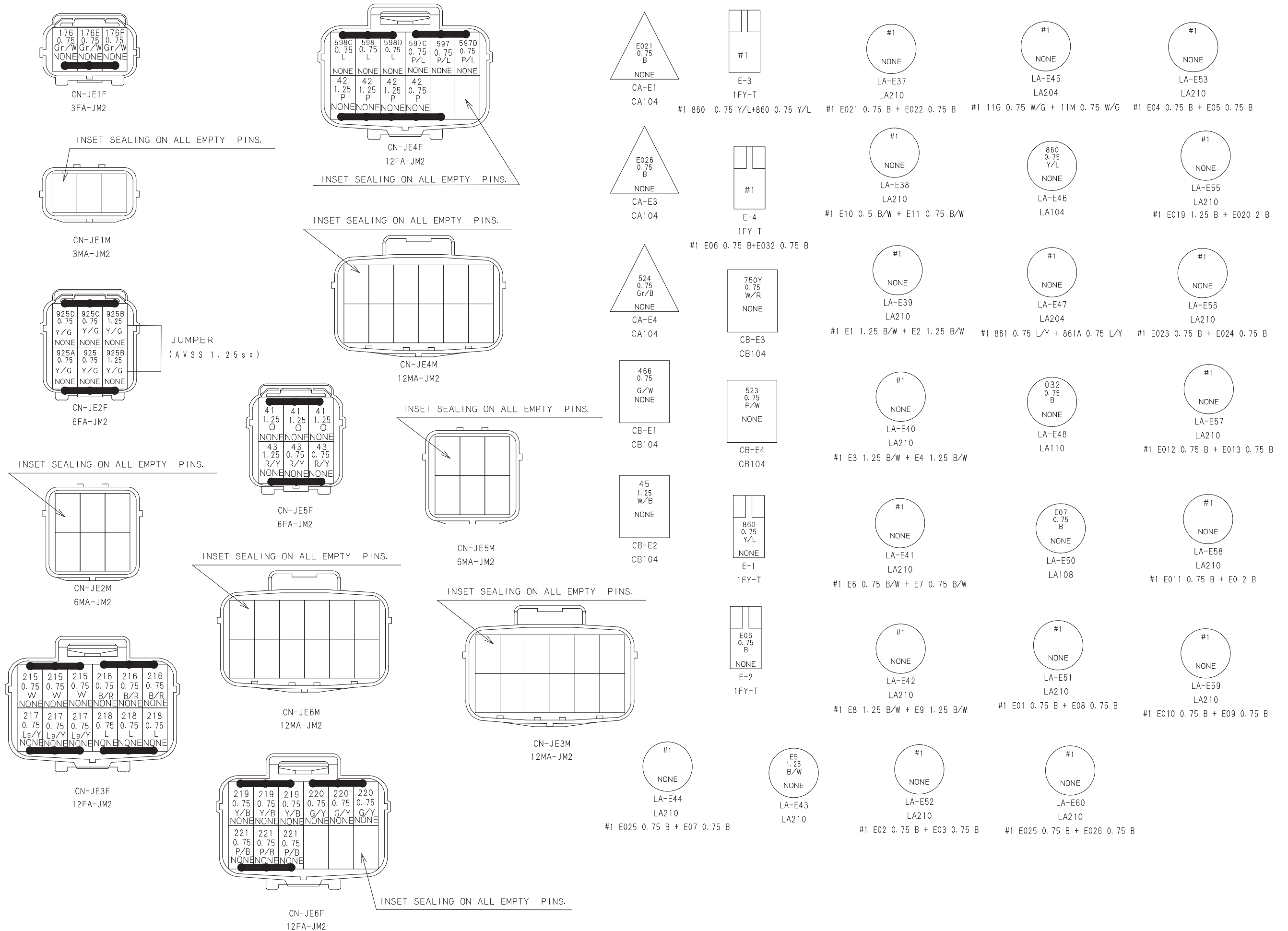

10. ELECTRIC SYSTEM

WIRE No. AND WIRE COLER LIST

WIRE NO	COLER	TYPE	SIZE	F R O M	2-WIRE CLAMP No.	CONNECTION	2-WIRE CLAMP No.	T	O
4	Y	AVSS	1.25	CN-849M					CN-851F
11G	W/G	AVSS	0.75	LA-E45	DS-E21				CN-716F
11M	W/G	AVSS	0.75	LA-E45	DS-E21				CN-853F
14	G/R	AVSS	0.75	CN-115F					CN-404M
15	Br	AVSS	1.25	CN-40F					CN-401F
31	L	AVSS	0.75	CN-116F					CN-404M
37	G	AVS	2	CN-848F					CN-852M
38	R/L	AVS	2	CN-871F					CN-852M
41	O	AVSS	1.25	CN-JE5F					CN-404M
41	O	AVSS	1.25	CN-JE5F					CN-115F
41	O	AVSS	1.25	CN-JE5F					CN-115F
42	P	AVSS	1.25	CN-JE4F					CN-404M
42	P	AVSS	0.75	CN-JE4F					CN-117F
42	P	AVSS	1.25	CN-JE4F					CN-116F
42	P	AVSS	0.75	CN-JE4F					CN-115F
43	R/Y	AVSS	1.25	CN-JE5F					CN-404M
43	R/Y	AVSS	0.75	CN-JE5F					CN-40F
43	R/Y	AVSS	0.75	CN-JE5F					CN-851F
45	W/B	AVSS	1.25	CN-709F					CB-E2
53F	L/R	AVSS	0.75	CN-116F					CN-404M
145C	Y/L	AVSS	0.75	CN-116F					CN-403M
146C	Gr	AVSS	0.75	CN-116F					CN-403M
147	O/L	AVSS	0.75	CN-115F					CN-404M
148	G/W	AVSS	0.75	CN-115F					CN-403M
149	L/W	AVSS	0.75	CN-115F					CN-403M
150	Br	AVSS	0.75	CN-117F					CN-405F
161A	Y/R	AVSS	0.75	CN-401F					CN-40F
166E	Lg/W	AVSS	0.75	CN-404M					CN-116F
167E	Lg/Y	AVSS	0.75	CN-404M					CN-116F
176	Gr/W	AVSS	0.75	CN-JE1F					CN-403M
176E	Gr/W	AVSS	0.75	CN-JE1F					CN-40F
176F	Gr/W	AVSS	0.75	CN-JE1F					CN-117F
212	G/W	AVSS	0.75	CN-842F					CN-404M
213	Y/W	AVSS	0.75	CN-842F					CN-404M
214	R/W	AVSS	0.75	CN-842F					CN-404M
215	W	AVSS	0.75	CN-405F					CN-JE3F
215	W	AVSS	0.75	CN-40F					CN-JE3F
215	W	AVSS	0.75	CN-117F					CN-JE3F
216	B/R	AVSS	0.75	CN-405F					CN-JE3F
216	B/R	AVSS	0.75	CN-41F					CN-JE3F
216	B/R	AVSS	0.75	CN-117F					CN-JE3F
217	Lg/Y	AVSS	0.75	CN-405F					CN-JE3F
217	Lg/Y	AVSS	0.75	CN-40F					CN-JE3F
217	Lg/Y	AVSS	0.75	CN-117F					CN-JE3F
218	L/O	AVSS	0.75	CN-405F					CN-JE3F
218	L/O	AVSS	0.75	CN-41F					CN-JE3F
218	L/O	AVSS	0.75	CN-117F					CN-JE3F
219	Y/B	AVSS	0.75	CN-405F					CN-JE6F
219	Y/B	AVSS	0.75	CN-41F					CN-JE6F
219	Y/B	AVSS	0.75	CN-117F					CN-JE6F
220	G/Y	AVSS	0.75	CN-405F					CN-JE6F
220	G/Y	AVSS	0.75	CN-41F					CN-JE6F
220	G/Y	AVSS	0.75	CN-117F					CN-JE6F
221	P/B	AVSS	0.75	CN-405F					CN-JE6F
221	P/B	AVSS	0.75	CN-40F					CN-JE6F
221	P/B	AVSS	0.75	CN-117F					CN-JE6F
347	Y/V	AVSS	0.75	CN-119F					CN-402F
365	L/R	AVSS	0.75	CN-119F					CN-402F
366	G/B	AVSS	0.75	CN-119F					CN-402F
398C	G/W	AVSS	0.75	CN-402F					CN-116F
445	R/Y	AVSS	0.75	CN-401F					CN-849M
466	G/W	AVSS	0.75	CB-E1					CN-700F
500	R/G	AVSS	0.75	CN-111F					CN-111F
501	Br/W	AVSS	0.75	CN-816F					CN-401F
502	G/Y	AVSS	0.75	CN-401F					CN-816F
503	L	AVSS	0.75	CN-816F					CN-401F
504	Y/L	AVSS	0.75	CN-111F					CN-111F
512	R	AVSS	0.75	CN-112F					CN-802F
513	W	AVSS	0.75	CN-112F					CN-802F
514	B	AVSS	0.75	CN-112F					CN-802F
515	Y/R	AVSS	0.75	CN-112F					CN-803F
516	G/W	AVSS	0.75	CN-112F					CN-803F
517	L/B	AVSS	0.75	CN-112F					CN-803F
518	Br/R	AVSS	0.75	CN-112F					CN-804F

WIRE NO	COLER	TYPE	SIZE	F R O M	2-WIRE CLAMP No.	CONNECTION	2-WIRE CLAMP No.	T	O
519	Lg/W	AVSS	0.75	CN-112F					CN-804F
520	O/B	AVSS	0.75	CN-112F					CN-804F
523	P/W	AVSS	0.75	CB-E4					CN-112F
524	Gr/B	AVSS	0.75	CA-E4					CN-112F
525	V/R	AVSS	0.75	CN-112F					CN-805F
526	Br/W	AVSS	0.75	CN-112F					CN-805F
527	Lg/B	AVSS	0.75	CN-112F					CN-805F
528	W/R	AVSS	0.75	CN-112F					CN-806F
529	B/W	AVSS	0.75	CN-112F					CN-806F
530	R/B	AVSS	0.75	CN-112F					CN-806F
531	R	AVSS	0.75	CN-113F					CN-807F
532	W	AVSS	0.75	CN-113F					CN-807F
533	B	AVSS	0.75	CN-113F					CN-807F
534	L/R	AVSS	0.75	CN-114F					CN-808F
535	Br/W	AVSS	0.75	CN-114F					CN-808F
536	P/B	AVSS	0.75	CN-114F					CN-808F
537	Gr/R	AVSS	0.75	CN-114F					CN-809F
538	Y/W	AVSS	0.75	CN-114F					CN-809F
539	O/B	AVSS	0.75	CN-114F					CN-809F
540	R	AVSS	0.75	CN-114F					CN-810F
541	W	AVSS	0.75	CN-114F					CN-810F
542	B	AVSS	0.75	CN-114F					CN-810F
543	G/R	AVSS	0.75	CN-114F					CN-811F
544	L/W	AVSS	0.75	CN-114F					CN-811F
545	Y/B	AVSS	0.75	CN-114F					CN-811F
546	Lg/R	AVSS	0.75	CN-114F					CN-812F
547	O/W	AVSS	0.75	CN-114F					CN-812F
548	Br/B	AVSS	0.75	CN-114F					CN-812F
549	V/R	AVSS	0.75	CN-114F					CN-813F
550	P/W	AVSS	0.75	CN-114F					CN-813F
551	Gr/B	AVSS	0.75	CN-114F					CN-813F
552	W/R	AVSS	0.75	CN-114F					CN-815F
553	B/W	AVSS	0.75	CN-114F					CN-815F
554	R/B	AVSS	0.75	CN-114F					CN-815F
555	Y/R	AVSS	0.75	CN-114F					CN-814F
556	Lg/W	AVSS	0.75	CN-114F					CN-814F
557	L/B	AVSS	0.75	CN-113F					CN-814F
597	P/L	AVSS	0.75	CN-JE4F					CN-117F
597D	P/L	AVSS	0.75	CN-JE4F					CN-836F
597C	P/L	AVSS	0.75	CN-JE4F					CN-40F
598	L	AVSS	0.75	CN-JE4F					CN-117F
598D	L	AVSS	0.75	CN-JE4F					CN-837F
598C	L	AVSS	0.75	CN-JE4F					CN-40F
601	R/W	AVSS	0.75	CN-851F					CN-119F
604	L/B	AVSS	0.75	CN-119F					CN-838F
605	Y/R	AVSS	0.75	CN-119F					CN-851F
606	G	AVSS	0.75	CN-119F					CN-40F
607	R/G	AVSS	0.75	CN-119F					CN-40F
608	Br/R	AVSS	0.75	CN-119F					CN-840F
609	P/L	AVSS	0.75	CN-119F					CN-841F
610	Gr/B	AVSS	0.75	CN-716F					CN-119F
611	B/Y	AVSS	0.75	CN-716F					CN-119F
612	W/L	AVSS	0.75	CN-716F					CN-119F
615	W/Y	AVSS	0.75	CN-843F					CN-117F
616	Br/W	AVSS	0.75	CN-843F					CN-117F
617	Y/G	AVSS	0.75	CN-851F					CN-848F
617	Y/G	AVSS	0.75	CN-851F					CN-871F
617	Y/G	AVSS	0.75	CN-851F					CN-117F
618	Lg	AVSS	0.75	CN-843F					CN-114F
619	L	AVSS	0.75	CN-843F					CN-114F
620	G	AVSS	0.75	CN-843F					CN-114F
621	O	AVSS	0.75	CN-114F					CN-843F
622	P	AVSS	0.75	CN-114F					CN-843F
750Y	W/R	AVSS	0.75	CN-401F					CB-E3
751	G/R	AVSS	0.75	CN-845F					CN-709F
752	Lg/R	AVSS	0.75	CN-844F					CN-709F
811	R/W	AVSS	1.25	CN-846F					CN-700F
812	P/L	AVSS	1.25	CN-846F					CN-700F
813	P	AVS	1.25	CN-700F					CN-847F
860	Y/L	AVSS	0.75	LA-E46					DS-E29 E-3
860	Y/L	AVSS	0.75	E-1					DS-E29 E-3
861	L/Y	AVSS	0.75	LA-E47	DS-E22				CN-401F
861A	L/Y	AVSS	0.75	LA-E47	DS-E22				CN-853F
923	L/O	AVSS	0.75	CN-823F					CN-401F
924	G/O	AVSS	0.75	CN-822F					CN-401F
925D	Y/G	AVSS	0.75	CN-JE2F					CN-819F
925C	Y/G	AVSS	0.75	CN-JE2F					CN-820F
925B	Y/G	AVSS	1.25	CN-JE2F					CN-JE2F
925A	Y/G	AVSS	0.75	CN-821F					CN-JE2F
925	Y/G	AVSS	0.75	CN-401F					CN-JE2F
956	L/Y	AVSS	0.75	CN-118F					CN-851F
956A	L/Y	AVSS	0.75	CN-716F					CN-851F
958	G	AVSS	0.75	CN-118F					DS-E23 CN-816F
958	G	AVSS	0.75	CN-403M					DS-E23 CN-816F
959	L	AVSS							

RELAY HARNESS

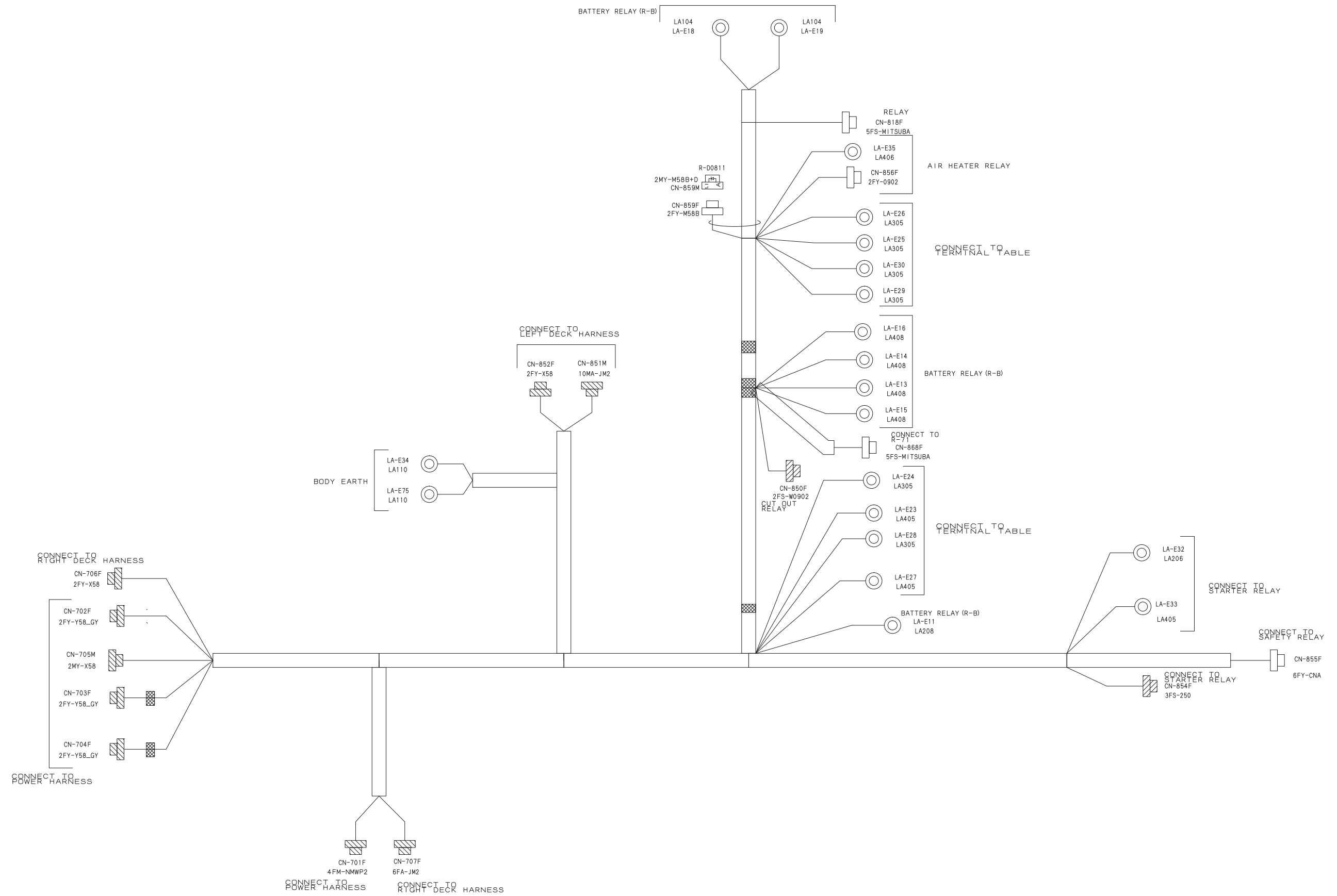

10. ELECTRIC SYSTEM

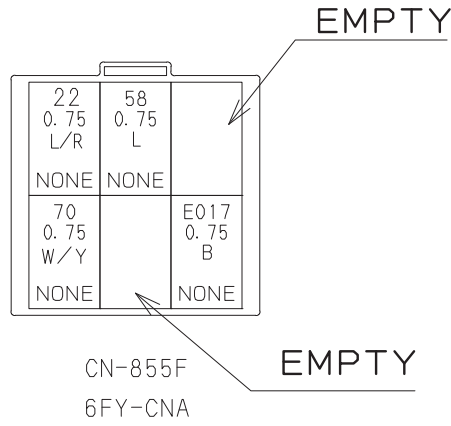
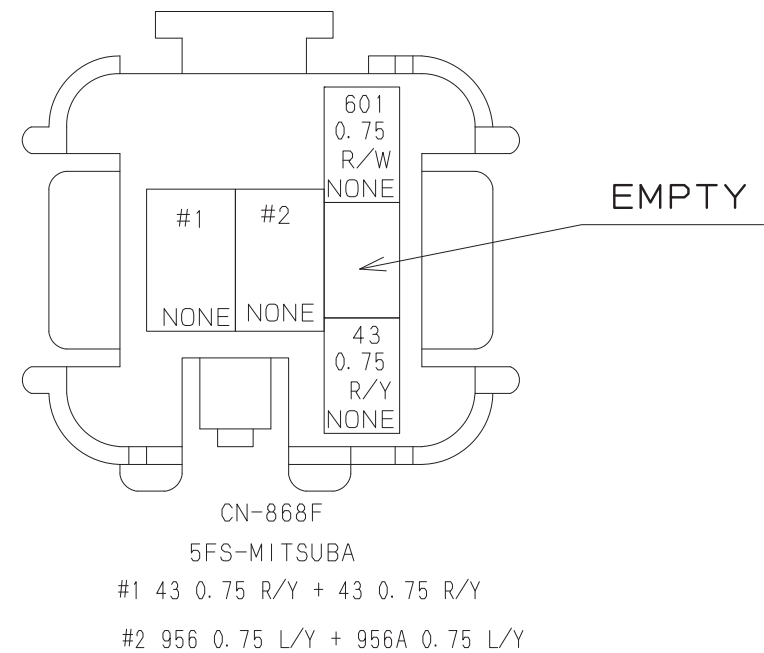
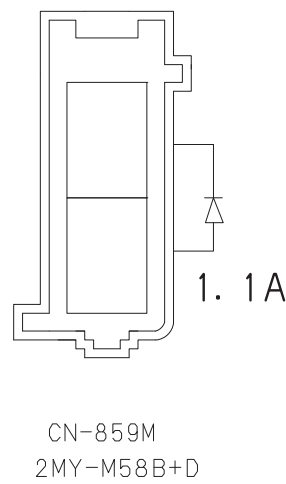
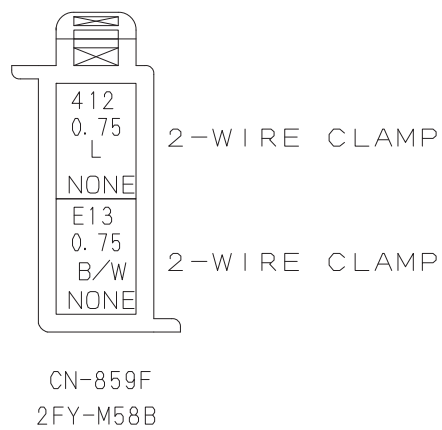
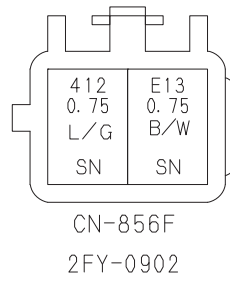
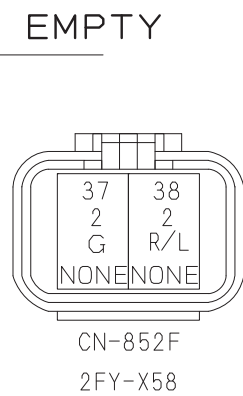
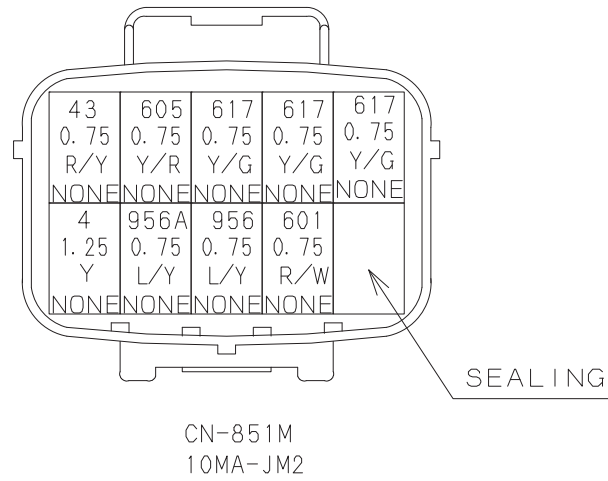
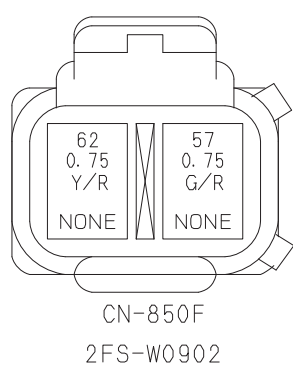
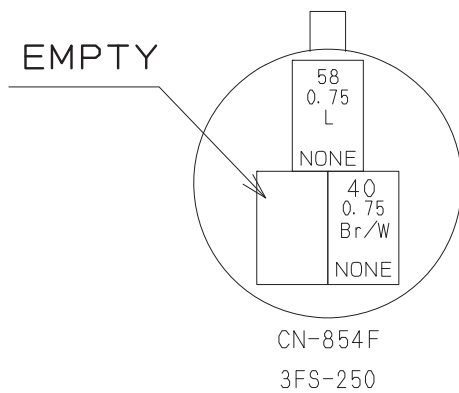
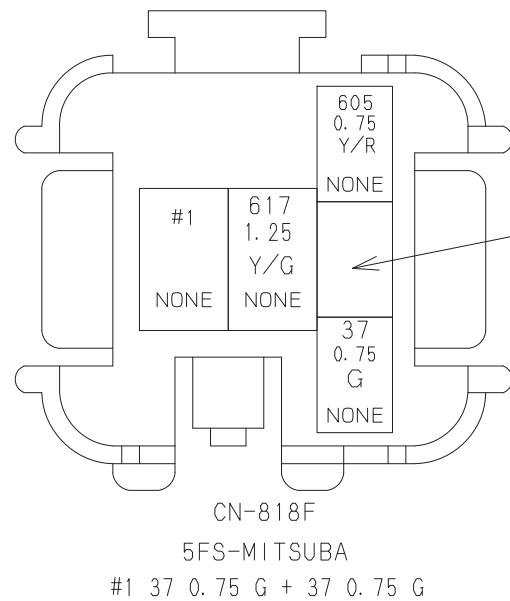
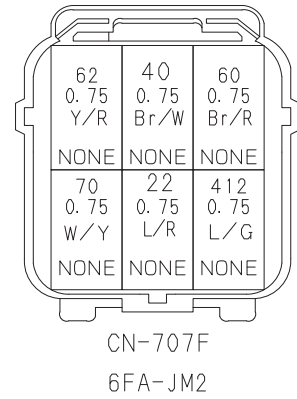
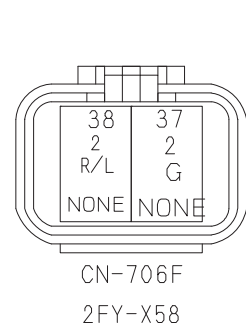
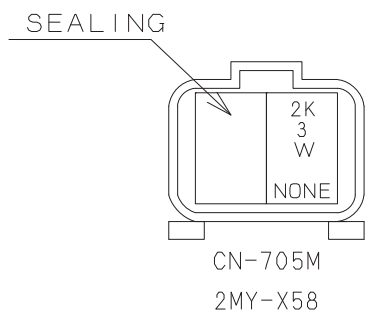
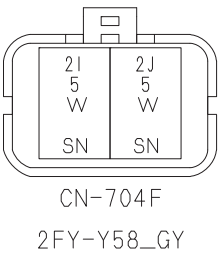
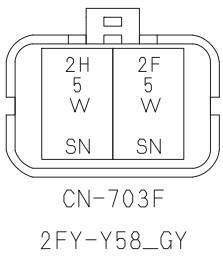
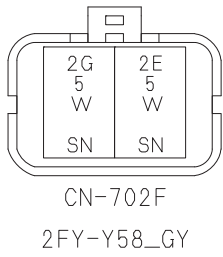
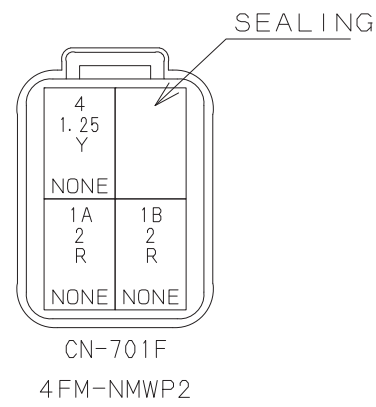

#1 NONE LA-E11 LA208	60 0.75 Br/R NONE LA-E18 LA104	2G 5 W NONE LA-E26 LA305	2K 3 W NONE LA-E32 LA206
#1 1A 2 R + 1B 2 R	2A 15 W NONE LA-E13 LA408	57 0.75 G/R NONE LA-E19 LA104	2B 15 W NONE LA-E27 LA405
2B 15 W NONE LA-E14 LA408	2A 15 W NONE LA-E23 LA405	2H 5 W NONE LA-E28 LA305	E017 0.75 B NONE LA-E34 LA110
2C 15 W NONE LA-E15 LA408	2E 5 W NONE LA-E24 LA305	2I 5 W NONE LA-E29 LA305	2L 15 W NONE LA-E35 LA406
2L 15 W NONE LA-E16 LA408	2F 5 W NONE LA-E25 LA305	2J 5 W NONE LA-E30 LA305	E13 0.75 B/W NONE LA-E75 LA110

WIRE No. AND WIRE COLOR LIST

No.	COLOR	TYPE	SIZE	FROM	2-WIRE CLAMP No.	CONNECTION	2-WIRE CLAMP No.	TO
1A	R	AVS	2	LA-E11	DS-E16			CN-701F
1B	R	AVS	2	LA-E11	DS-E16			CN-701F
2A	W	AV	15	LA-E23				LA-E13
2B	W	AV	15	LA-E14				LA-E27
2C	W	AV	15	LA-E33				LA-E15
2E	W	AVS	5	CN-702F				LA-E24
2F	W	AVS	5	CN-703F				LA-E25
2G	W	AVS	5	CN-702F				LA-E26
2H	W	AVS	5	CN-703F				LA-E28
2I	W	AVS	5	CN-704F				LA-E29
2J	W	AVS	5	CN-704F				LA-E30
2K	W	AVS	3	LA-E32				CN-705M
2L	W	AV	15	LA-E35				LA-E16
4	Y	AVSS	1.25	CN-701F				CN-851M
22	L/R	AVSS	0.75	CN-707F				CN-855F
37	G	AVS	2	CN-706F				JS-B01
37A	G	AVS	2	JS-B01				CN-852F
37C	G	AVSS	0.75	JS-B01			DS-E1	CN-818F
37E	G	AVSS	0.75	CN-818F			DS-E1	CN-818F
38	R/L	AVS	2	CN-706F				CN-852F
40	Br/W	AVSS	0.75	CN-707F				CN-854F
43C	R/Y	AVSS	0.75	CN-851M			DS-E2	CN-868F
43E	R/Y	AVSS	0.75	CN-868F			DS-E2	CN-868F
57	G/R	AVSS	0.75	CN-850F				LA-E19
58	L	AVSS	0.75	CN-854F				CN-855F
60	Br/R	AVSS	0.75	CN-707F				LA-E18
62	Y/R	AVSS	0.75	CN-707F				CN-850F
70	w/Y	AVSS	0.75	CN-707F				CN-855F
412	L/G	AVSS	0.75	CN-707F			DS-E4	CN-859F
412	L/G	AVSS	0.75	CN-856F			DS-E4	CN-859F
601	R/W	AVSS	0.75	CN-851M				CN-868F
605	Y/R	AVSS	0.75	CN-851M				CN-818F
617	Y/G	AVSS	1.25	CN-818F				JS-B02
617	Y/G	AVSS	0.75	CN-851M				JS-B02
617	Y/G	AVSS	0.75	JS-B03				JS-B02
617	Y/G	AVSS	0.75	JS-B03				CN-851M
617	Y/G	AVSS	0.75	JS-B03				CN-851M
956	L/Y	AVSS	0.75	CN-851M			DS-E3	CN-868F
956A	L/Y	AVSS	0.75	CN-851M			DS-E3	CN-868F
E017	B	AVSS	0.75	CN-855F				LA-E34
E13	B/W	AVSS	0.75	LA-E75			DS-E5	CN-859F
E13	B/W	AVSS	0.75	CN-856F			DS-E5	CN-859F

10. ELECTRIC SYSTEM

4. ELECTRICAL PART OF RIGHT DECK

SOL : SOLENOID VALVE
 SW : SWITCH
 PSW : PRESSURE SWITCH
 ATT. : ATTACHMENT
 C/W : COUNTER WEIGHT
 CB/W : CARBODY WEIGHT

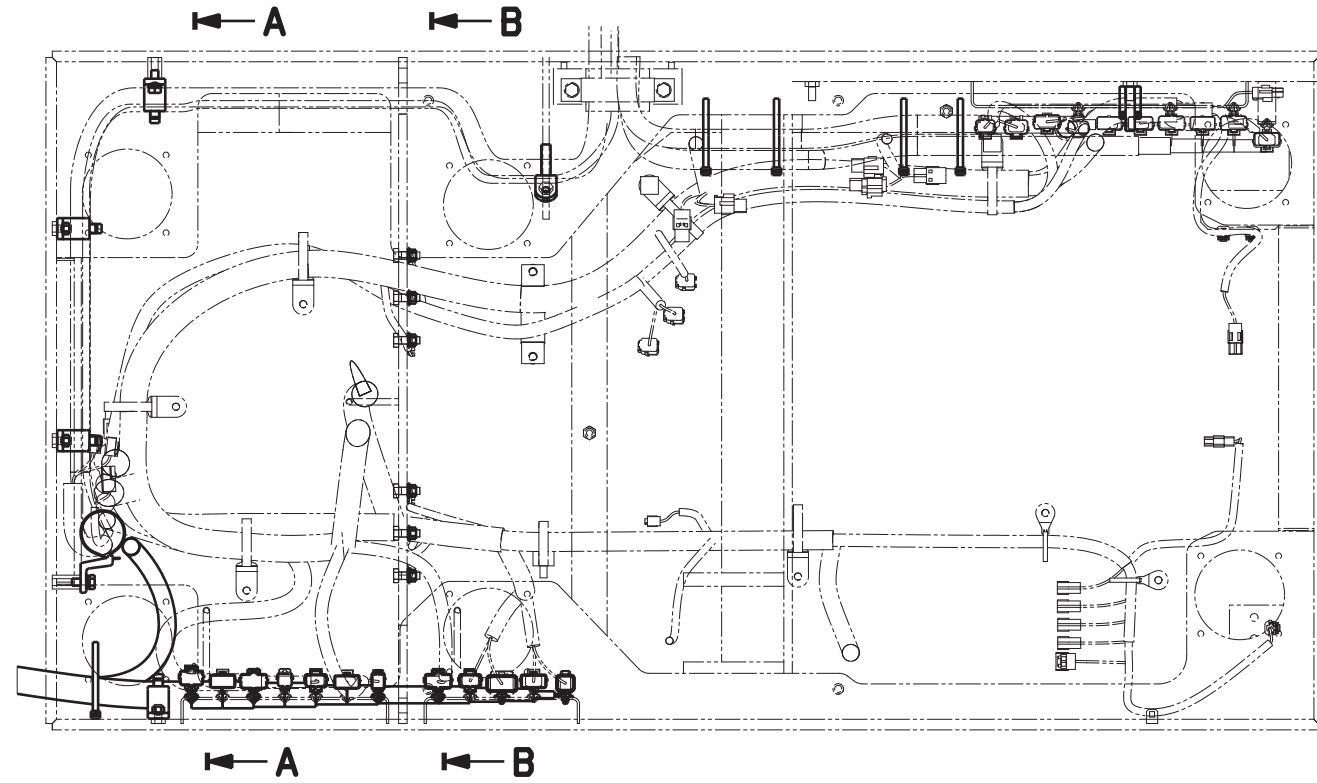
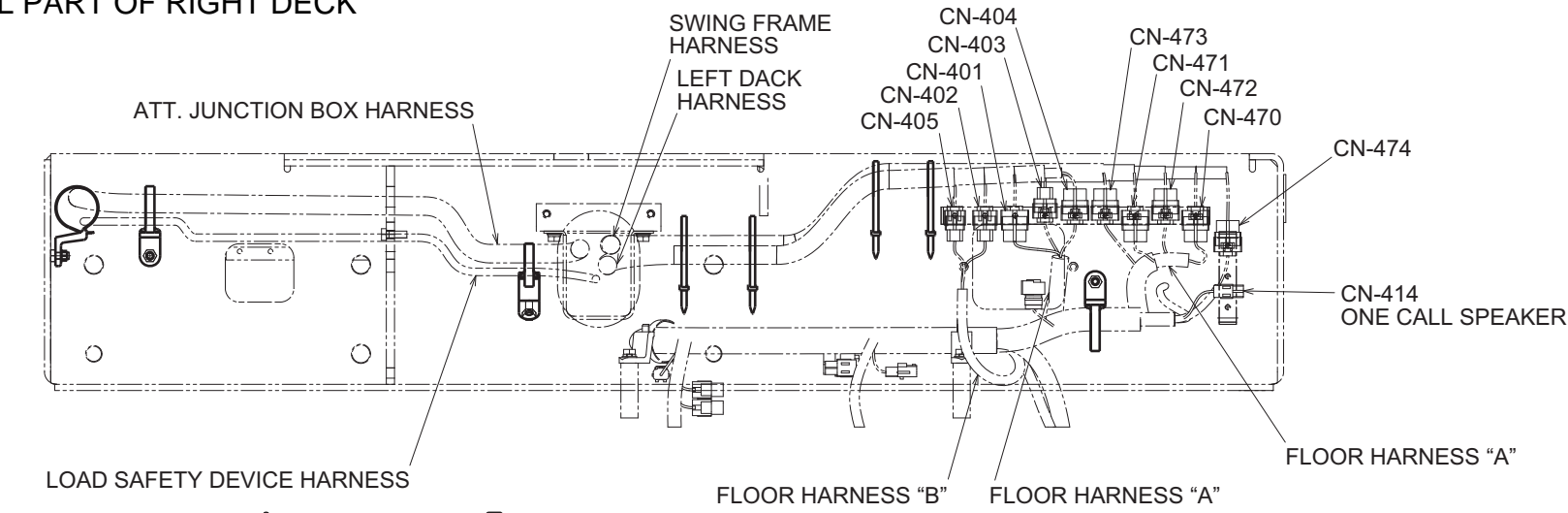

DETAIL OF CAB LOWER DECK

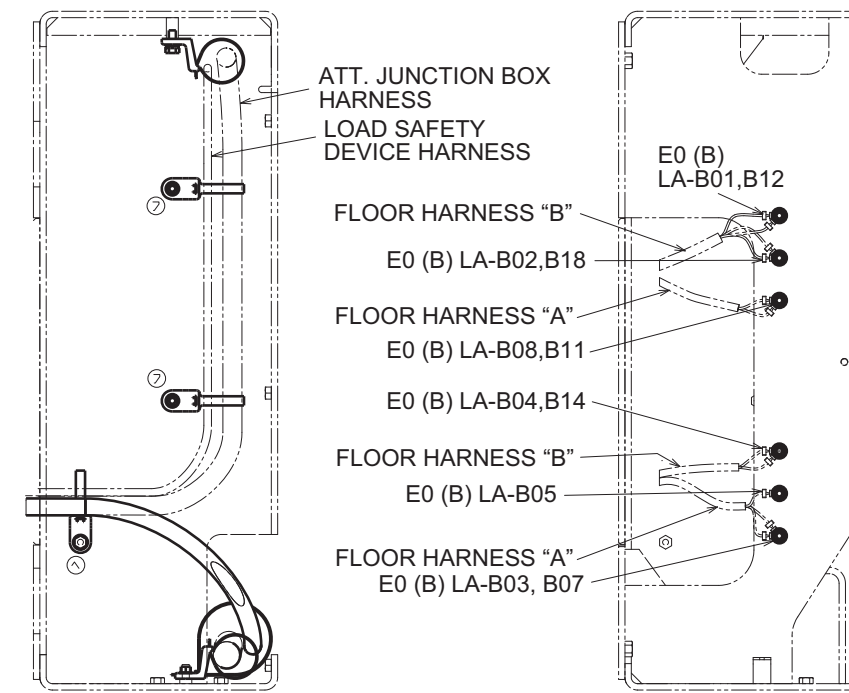

SECTION "A-A"

SECTION "B-B"

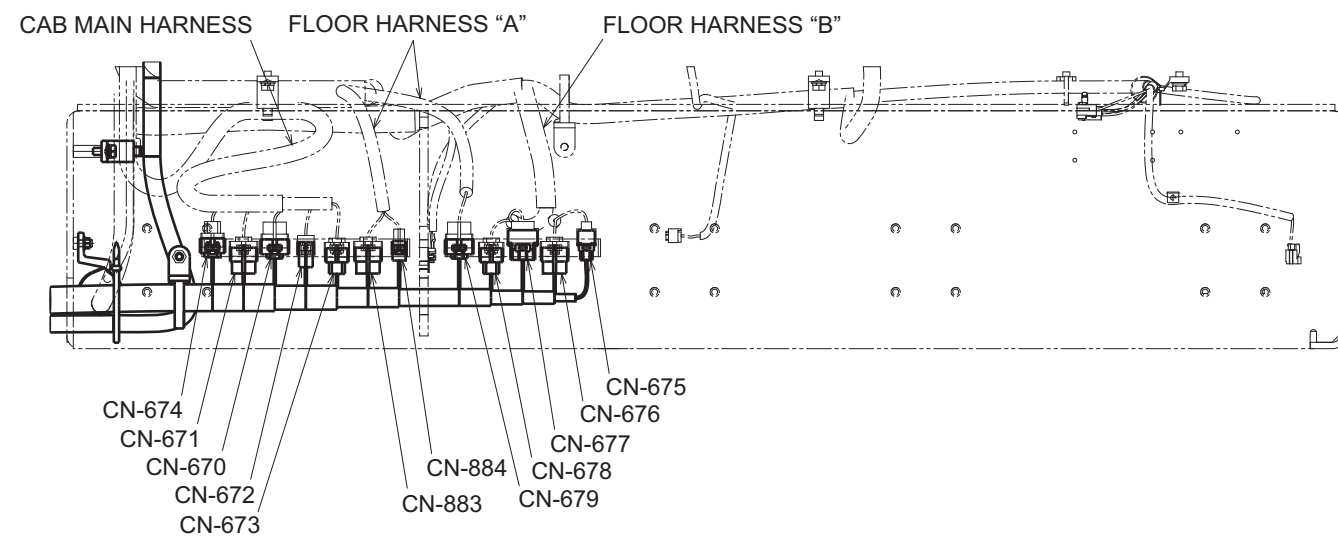

10. ELECTRIC SYSTEM

SOL : SOLENOID VALVE
 SW : SWITCH
 PSW : PRESSURE SWITCH
 ATT. : ATTACHMENT
 C/W : COUNTER WEIGHT
 CB/W : CARBODY WEIGHT

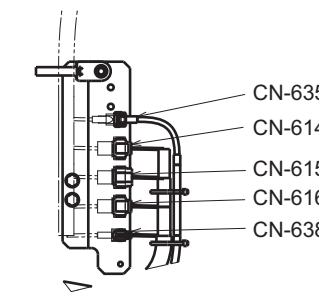
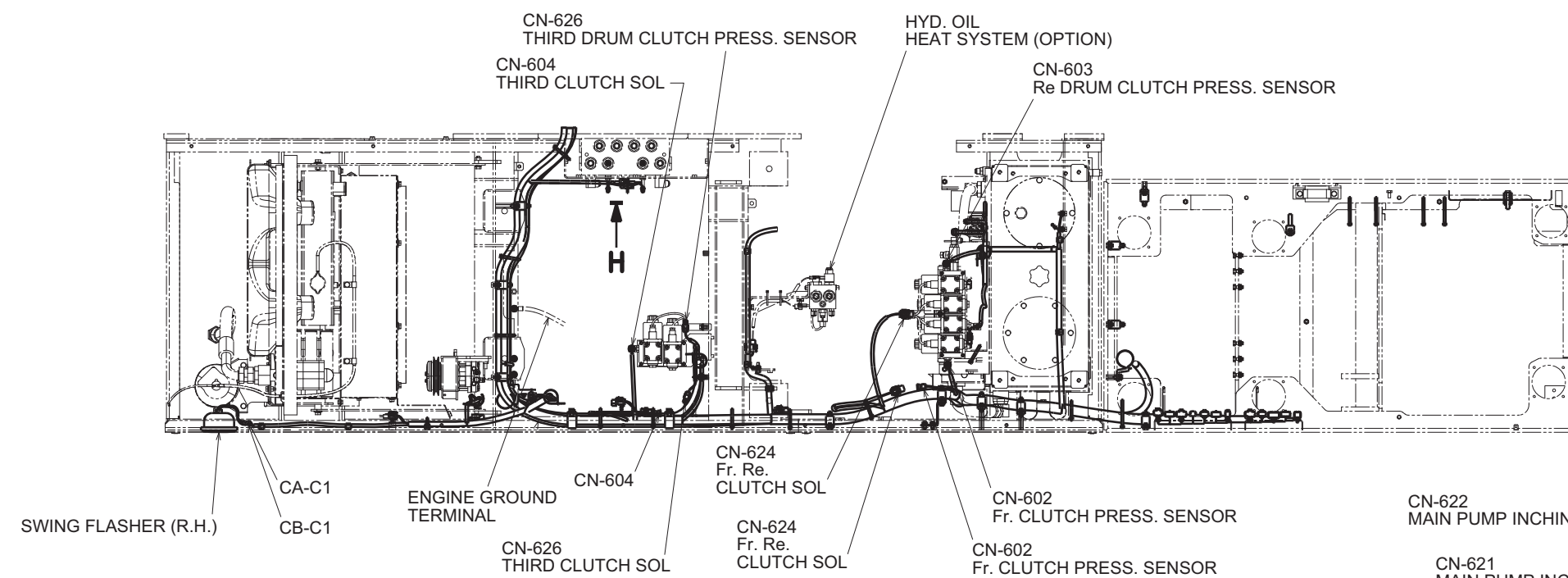

DETAIL OF "C"

VIEW FROM "E"
 (AT INDEPENDENT,
 CONFLUENCE SELECTED)

VIEW FROM "E"
 (AT CONFLUENCE)

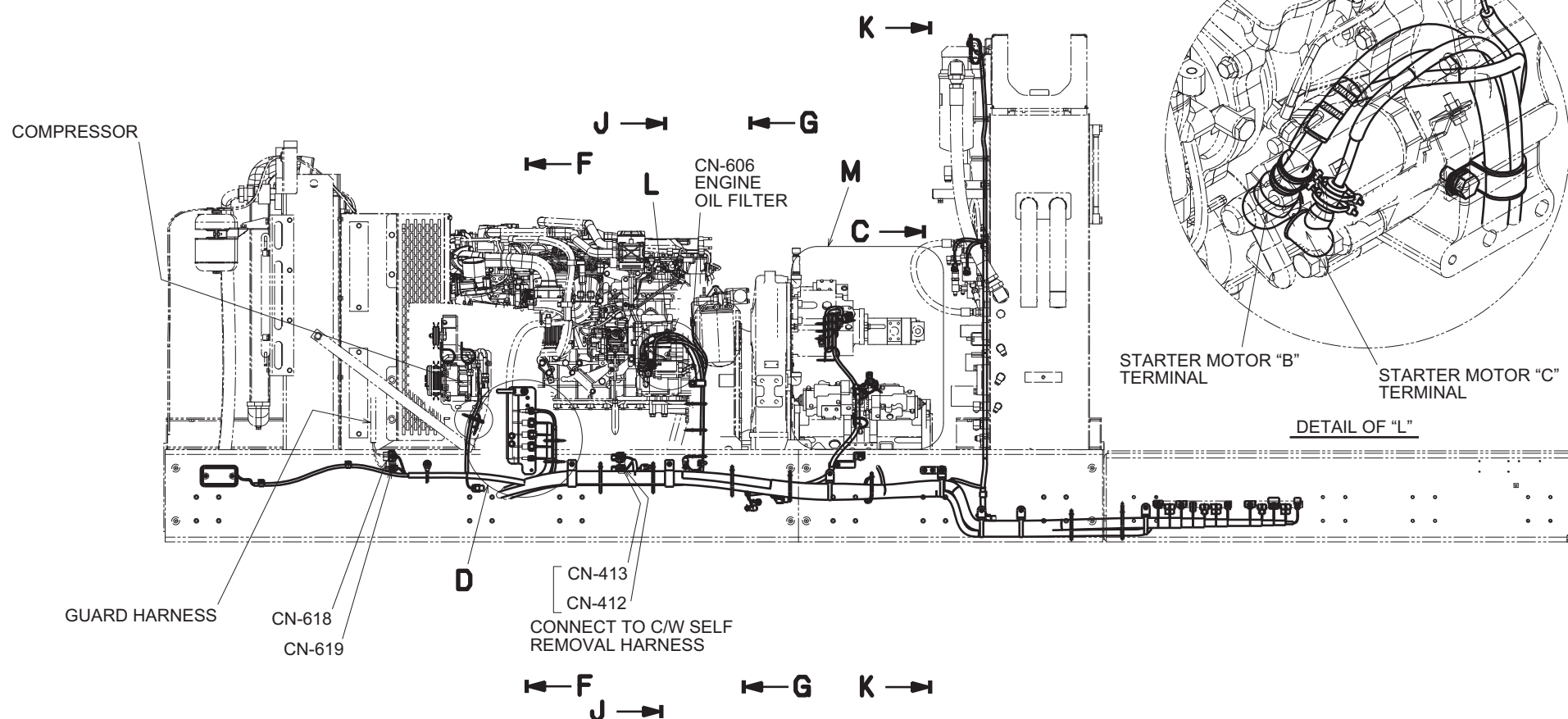

CN-622 (CONNECT WHEN INDEPENDENT,
 CONFLUENCE SELECTED)
 MAIN PUMP INCHING SPEED
 (FEATHERING) SOL

CN-610
 COOLING LINE FILTER
 CLOGGED LS

CN-620
 Qmax CUT SOL
 CN-621
 MAIN PUMP INCHING P1 SOL

CN-603
 Re. CLUTCH PRESS. SENSOR

VIEW FROM "C"

SOL : SOLENOID VALVE
 SW : SWITCH
 PSW : PRESSURE SWITCH
 ATT. : ATTACHMENT
 C/W : COUNTER WEIGHT
 CB/W : CARBODY WEIGHT

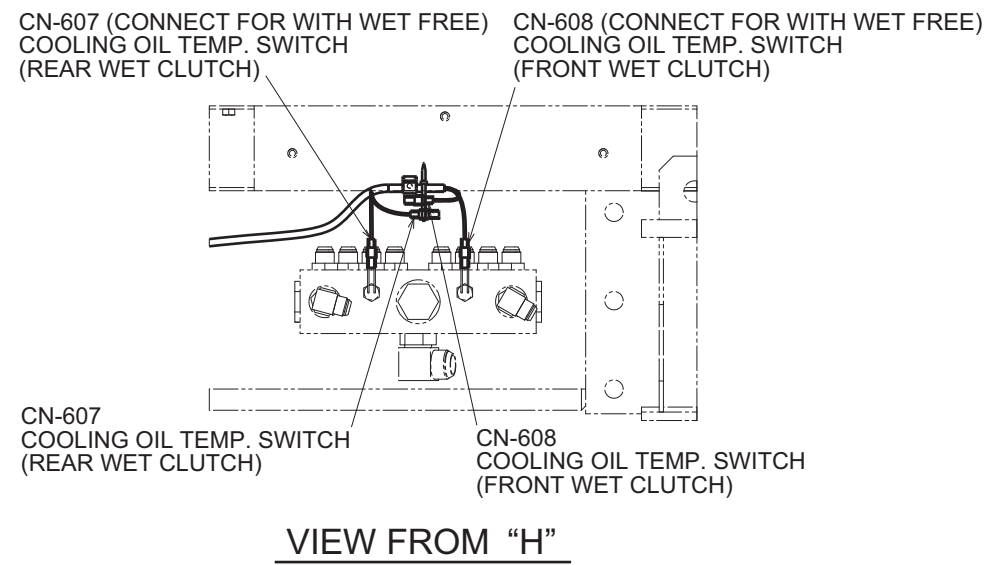
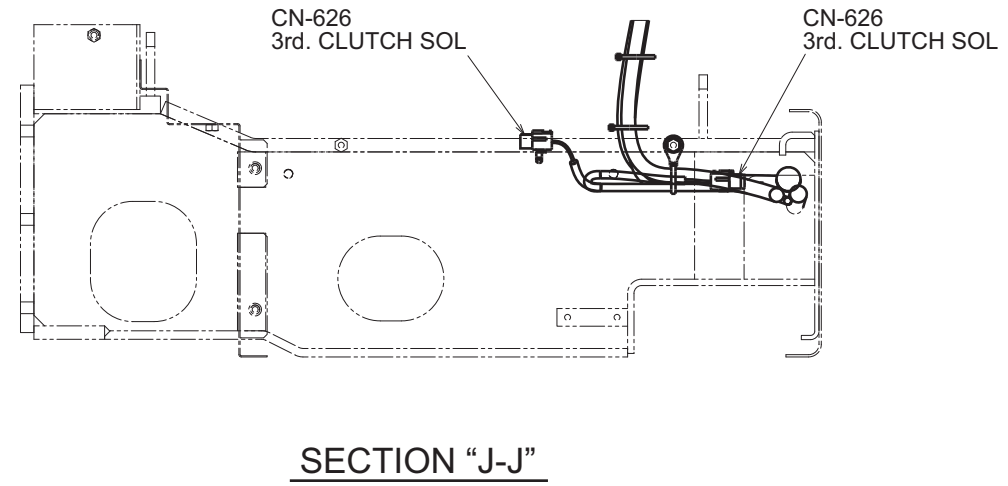
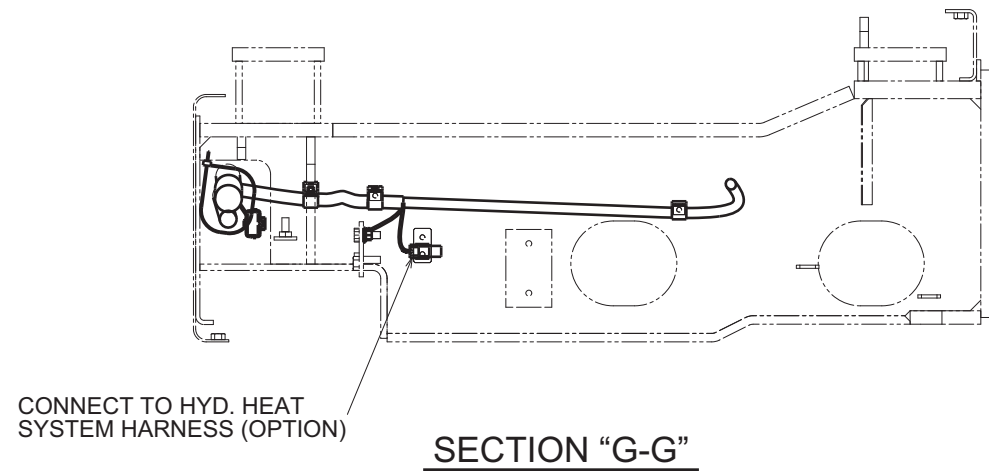

SOL : SOLENOID VALVE
 SW : SWITCH
 PSW : PRESSURE SWITCH
 ATT. : ATTACHMENT
 C/W : COUNTER WEIGHT
 CB/W : CARBODY WEIGHT

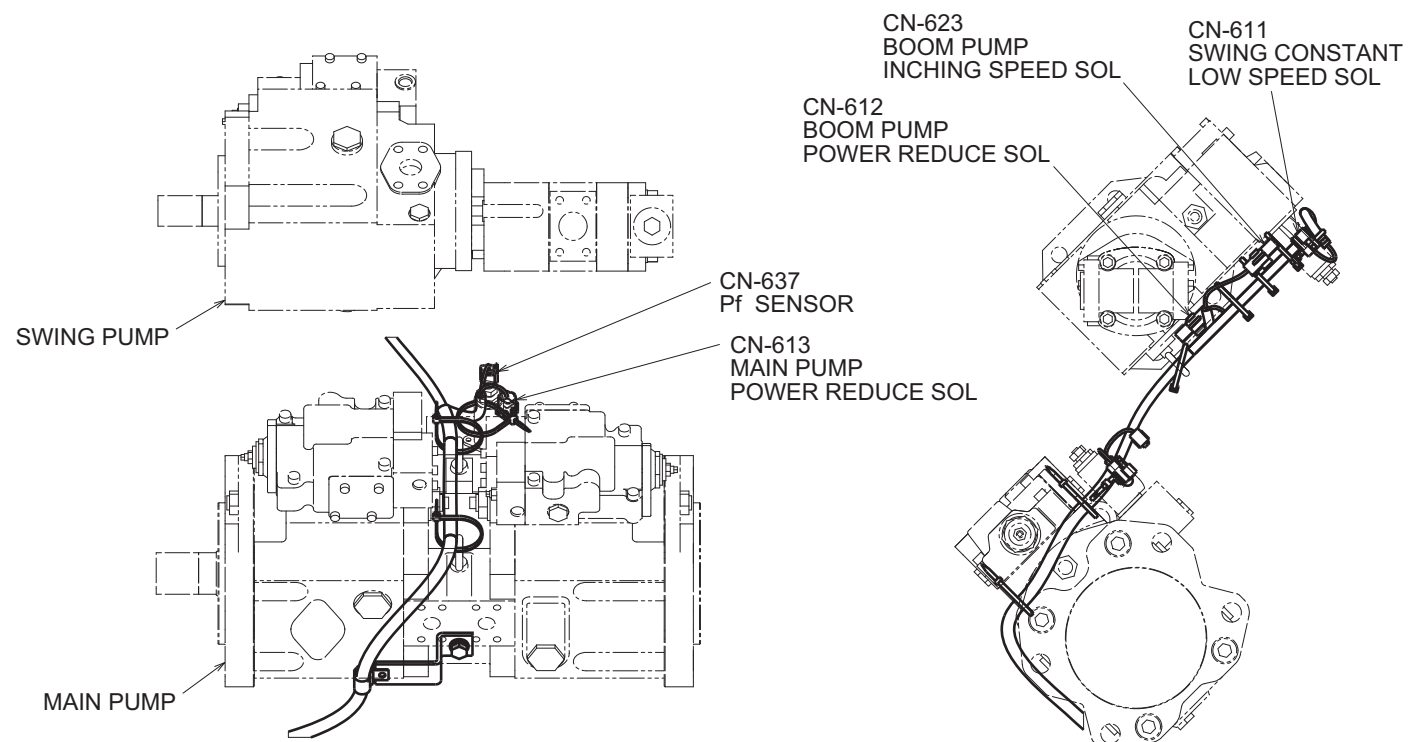

DETAIL OF "M"
 (AT CONFLUENCE)

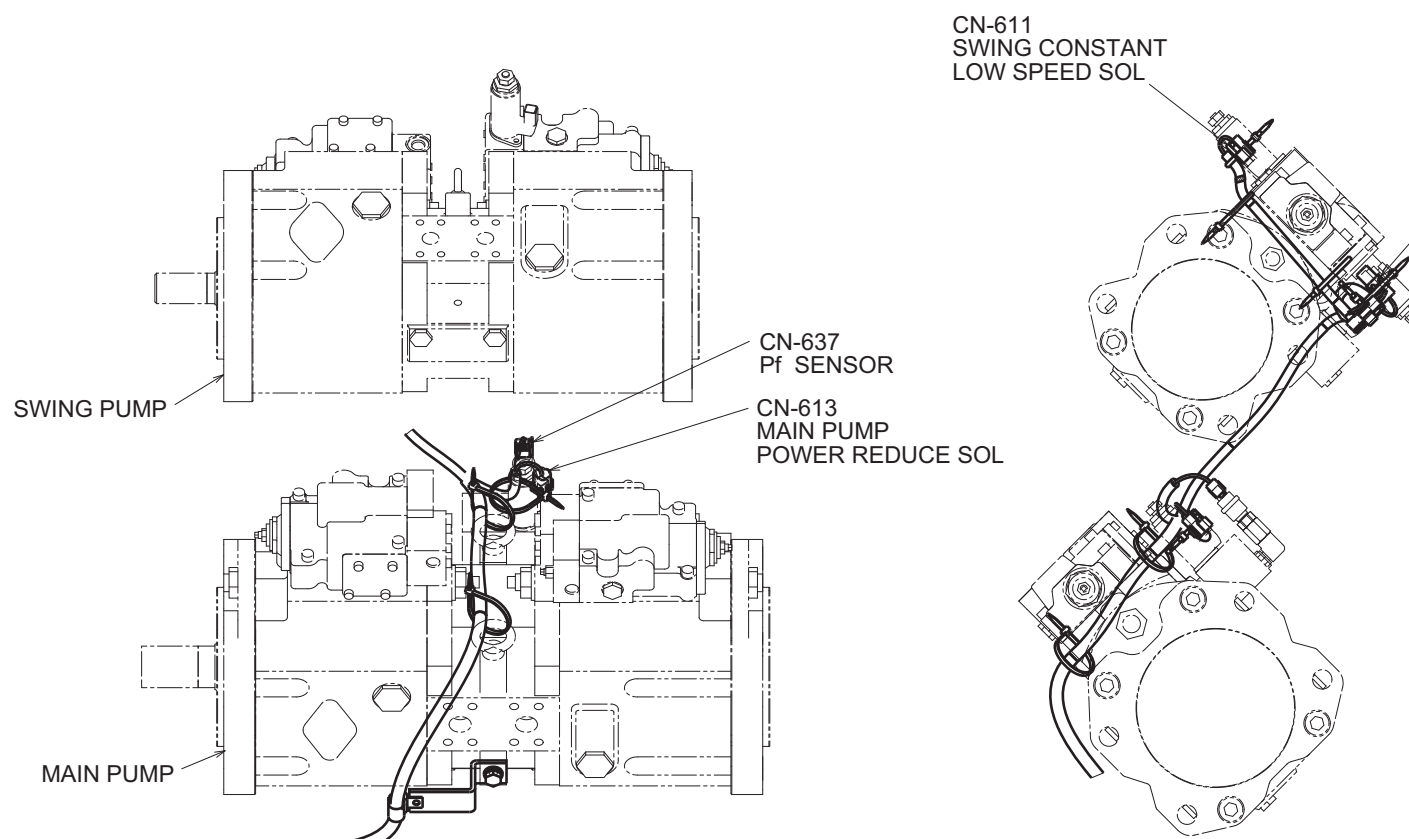
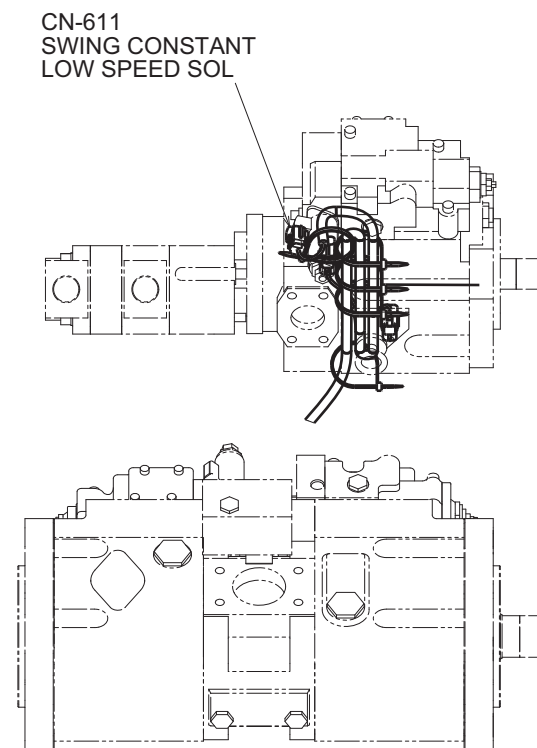

DETAIL OF "M"
 (AT INDEPENDENT,
 CONFLUENCE SELECTED)

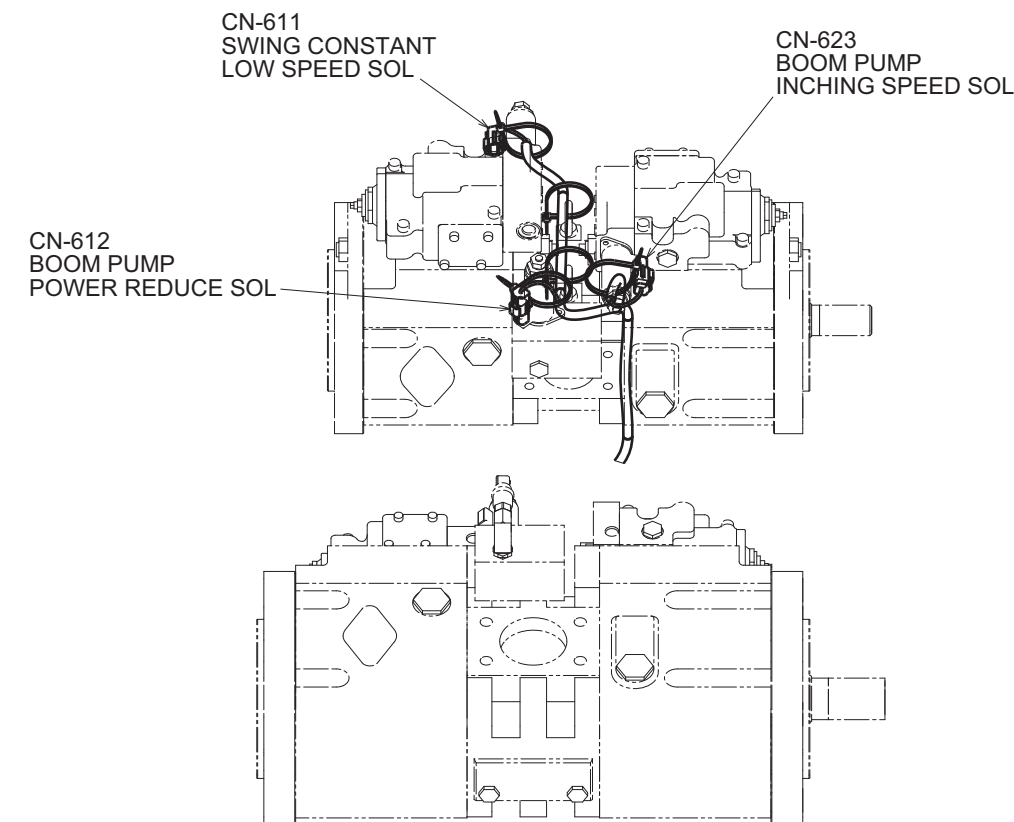

10. ELECTRIC SYSTEM

RIGHT DECK HARNESS

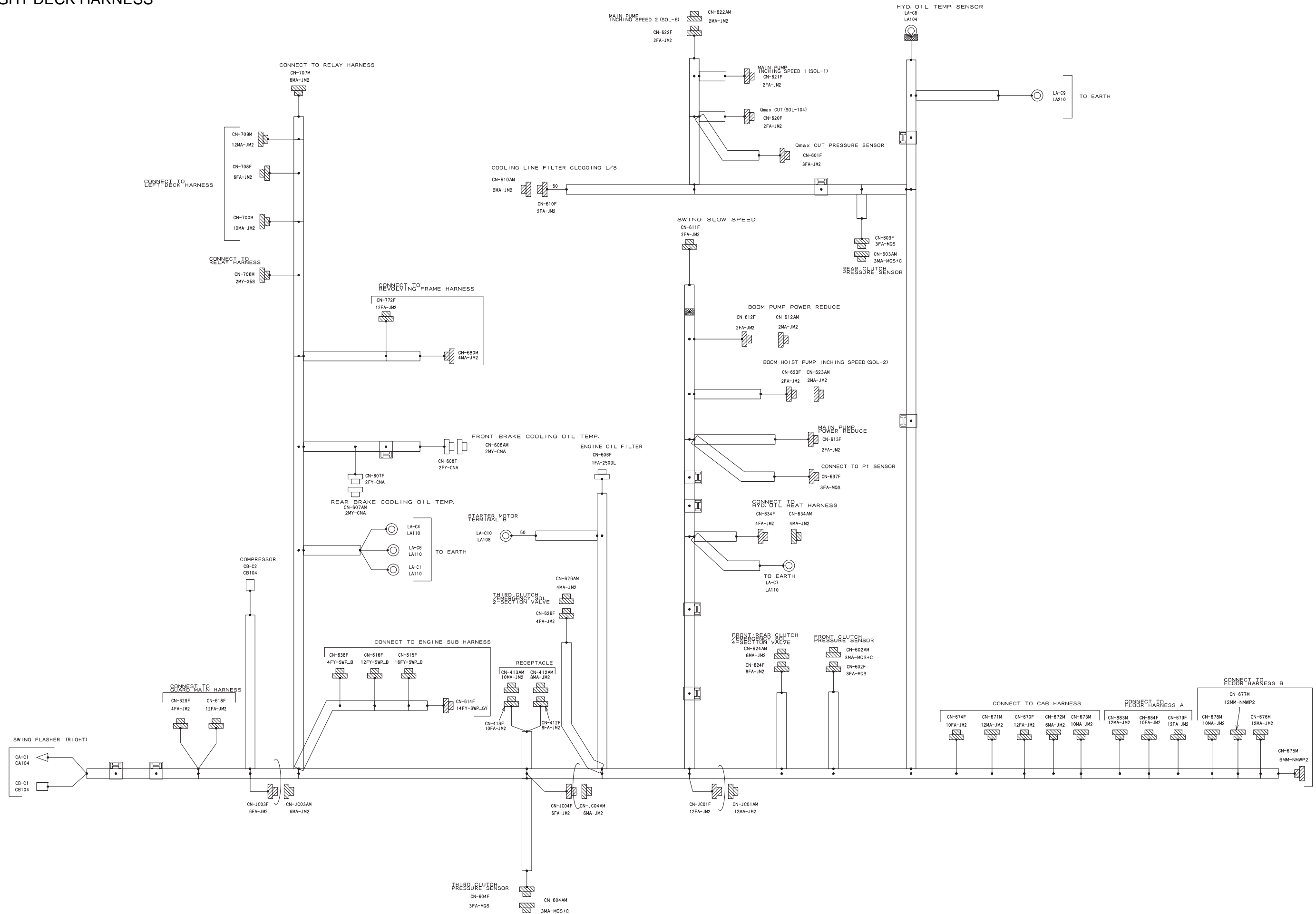

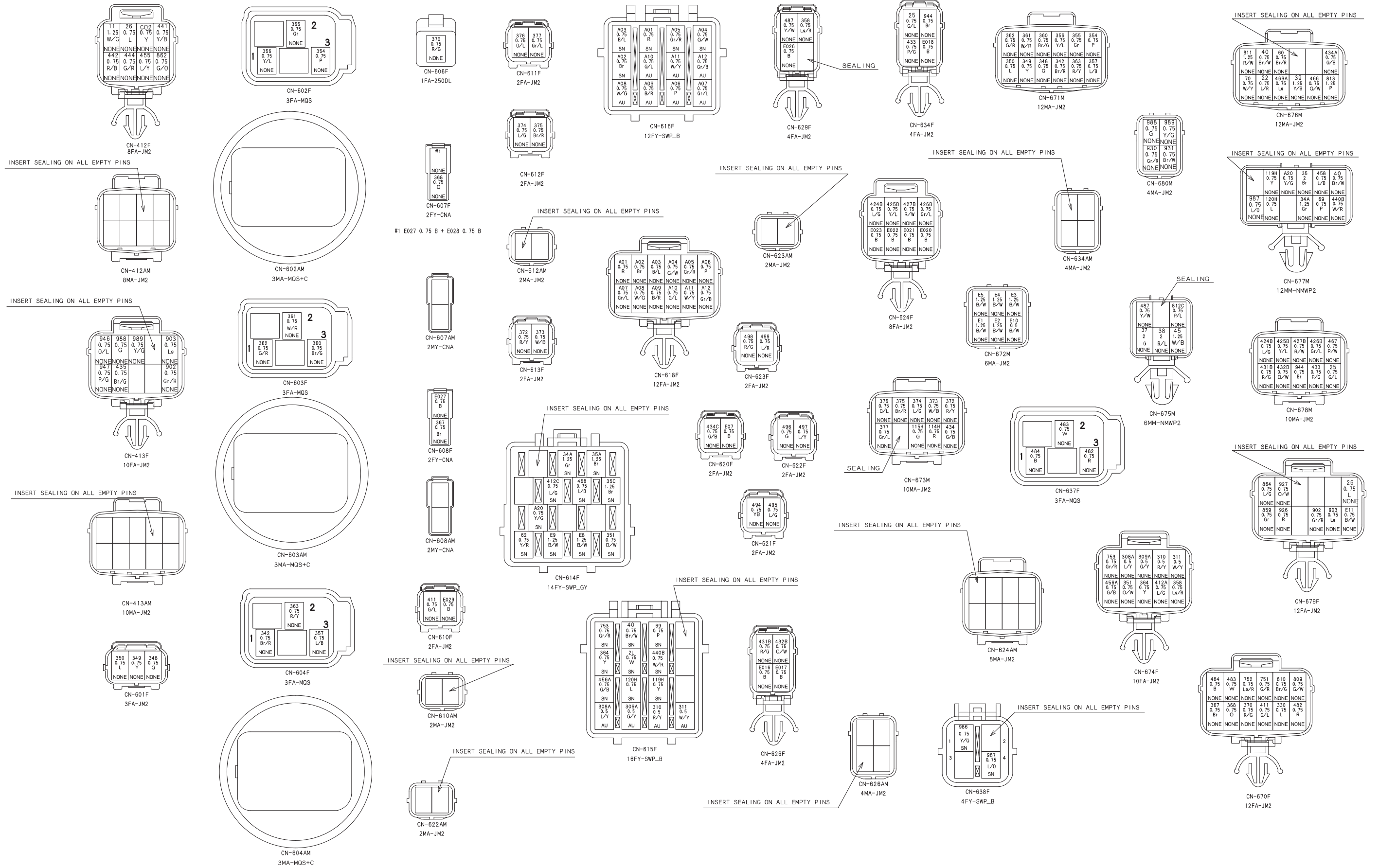

10. ELECTRIC SYSTEM

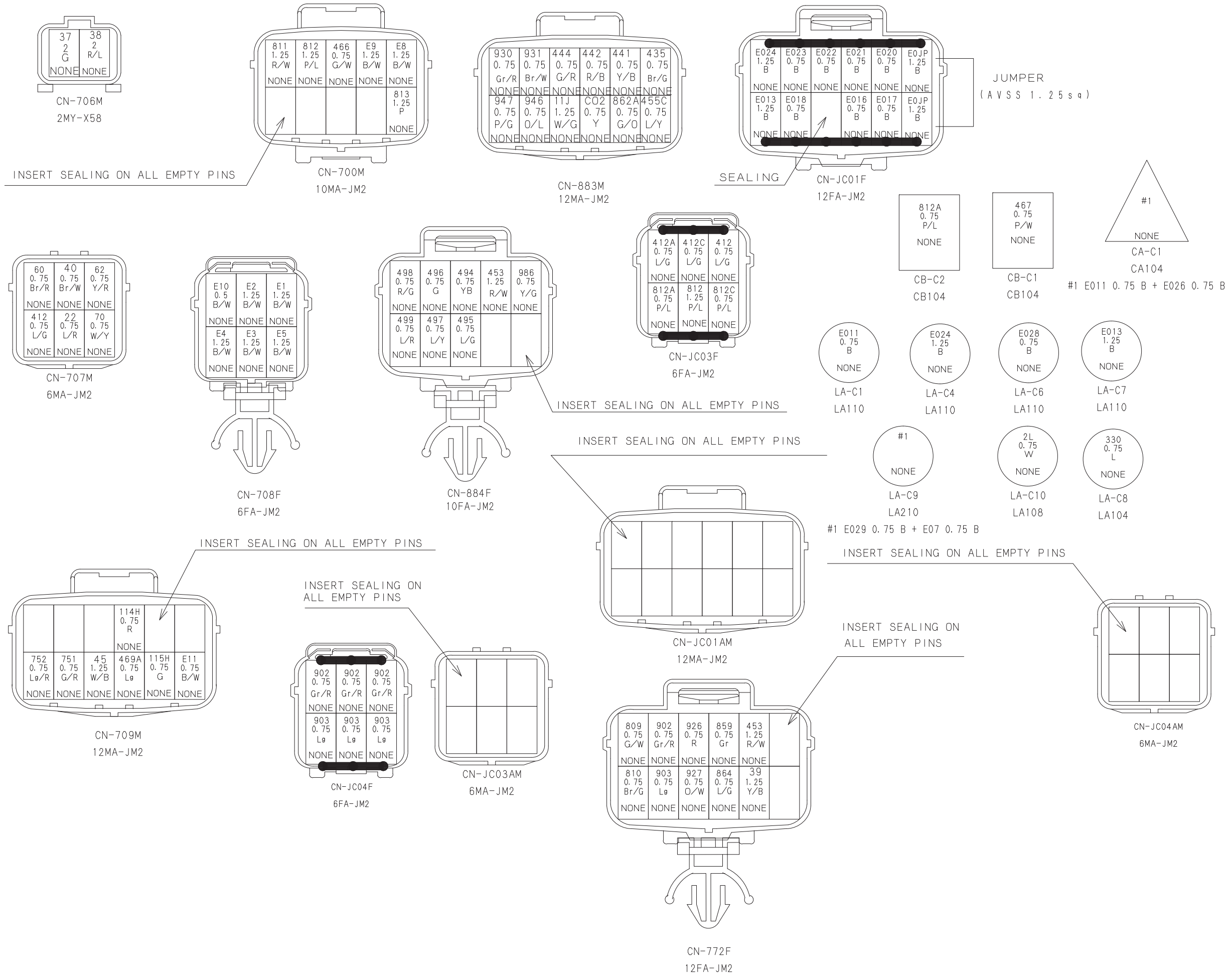

WIRE No. AND WIRE COLOR LIST

No.	COLOR	TYPE	SIZE	FROM	2-WIRE CLAMP No.	CONNECTION	2-WIRE CLAMP No.	TO
2L	W	AVSS	0.75	LA-C10				CN-615F
11	W/G	AVSS	1.25	CN-412F				CN-883M
22	L/R	AVSS	0.75	CN-676M				CN-707M
25	G/L	AVSS	0.75	CN-634F				CN-678M
26	L	AVSS	0.75	CN-412F				CN-679F
34A	Gr	AVSS	1.25	CN-677M				CN-614F
35	Br	AVS	2	CN-677M				JSC3
35A	Br	AVSS	1.25	CN-614F				JSC3
35C	Br	AVSS	1.25	CN-614F				JSC3
37	G	AVS	2	CN-675M				CN-706M
38	R/L	AVS	2	CN-675M				CN-706M
39	Y/B	AVSS	1.25	CN-772F				CN-676M
40	Br/W	AVSS	0.75	CN-707M				CN-676M
40	Br/W	AVSS	0.75	CN-677M				CN-615F
45	W/B	AVSS	1.25	CN-709M				CN-675M
60	Br/R	AVSS	0.75	CN-676M				CN-707M
62	Y/R	AVSS	0.75	CN-707M				CN-614F
69	P	AVSS	0.75	CN-677M				CN-615F
70	W/Y	AVSS	0.75	CN-707M				CN-676M
308A	L/Y	AVSS	0.5	CN-674F				CN-615F
309	GY	AVSS	0.5	CN-674F				CN-615F
310	RY	AVSS	0.5	CN-674F				CN-615F
311	W/Y	AVSS	0.5	CN-674F				CN-615F
330	L	AVSS	0.75	LA-C8				CN-670F
342	Br/R	AVSS	0.75	CN-671M				CN-604F
348	G	AVSS	0.75	CN-671M				CN-601F
349	Y	AVSS	0.75	CN-671M				CN-601F
350	L	AVSS	0.75	CN-671M				CN-601F
351	O/W	AVSS	0.75	CN-614F				CN-674F
354	P	AVSS	0.75	CN-671M				CN-602F
355	Gr	AVSS	0.75	CN-671M				CN-602F
356	Y/L	AVSS	0.75	CN-671M				CN-602F
357	L/B	AVSS	0.75	CN-671M				CN-604F
358	Lg/R	AVSS	0.75	CN-674F				CN-629F
360	Br/G	AVSS	0.75	CN-671M				CN-603F
361	W/R	AVSS	0.75	CN-671M				CN-603F
362	G/R	AVSS	0.75	CN-671M				CN-603F
363	R/Y	AVSS	0.75	CN-671M				CN-604F
364	Y	AVSS	0.75	CN-674F				CN-615F
367	Br	AVSS	0.75	CN-670F				CN-608F
368	O	AVSS	0.75	CN-670F				CN-607F
370	R/G	AVSS	0.75	CN-670F				CN-606F
411	G/L	AVSS	0.75	CN-670F				CN-610F
412	L/G	AVSS	0.75	CN-JC03F				CN-707M
412A	L/G	AVSS	0.75	CN-JC03F				CN-674F
412C	L/G	AVSS	0.75	CN-JC03F				CN-614F
424B	L/G	AVSS	0.75	CN-624F				CN-678M
425B	Y/L	AVSS	0.75	CN-624F				CN-678M
426B	Gr/L	AVSS	0.75	CN-624F				CN-678M
427B	R/W	AVSS	0.75	CN-624F				CN-678M
431B	R/G	AVSS	0.75	CN-626F				CN-678M
432B	O/W	AVSS	0.75	CN-626F				CN-678M
433	P/G	AVSS	0.75	CN-634F				CN-678M
434	G/B	AVSS	0.75	CN-673M				JS01
434A	G/B	AVSS	0.75	CN-676M				JS01
434C	G/B	AVSS	0.75	CN-620F				JS01
435	Br/G	AVSS	0.75	CN-413F				CN-883M
440B	W/R	AVSS	0.75	CN-677M				CN-615F
441	Y/B	AVSS	0.75	CN-412F				CN-883M
442	R/B	AVSS	0.75	CN-412F				CN-883M
444	G/R	AVSS	0.75	CN-412F				CN-883M
453	R/W	AVSS	1.25	CN-884F				CN-772F
455	L/Y	AVSS	0.75	CN-412F				CN-883M
456A	G/B	AVSS	0.75	CN-615F				CN-674F
458	L/B	AVSS	0.75	CN-614F				CN-677M
466	G/W	AVSS	0.75	CN-676M				CN-700M
467	P/W	AVSS	0.75	CB-C1				CN-678M
469A	Lg	AVSS	0.75	CN-676M				CN-709M
482	R	AVSS	0.75	CN-670F				CN-637F
483	W	AVSS	0.75	CN-670F				CN-637F
484	B	AVSS	0.75	CN-670F				CN-637F
487	Y/W	AVSS	0.75	CN-675M				CN-629F
751	G/R	AVSS	0.75	CN-709M				CN-670F
752	Lg/R	AVSS	0.75	CN-709M				CN-670F
753	Gr/R	AVSS	0.75	CN-674F				CN-615F
809	G/W	AVSS	0.75	CN-772F				CN-670F
810	Br/G	AVSS	0.75	CN-772F				CN-670F
811	R/W	AVSS	1.25	CN-676M				CN-700M
812	P/L	AVSS	1.25	CN-JC03F				CN-700M
812A	P/L	AVSS	0.75	CN-JC03F				CB-C2
812C	P/L	AVSS	0.75	CN-JC03F				CN-675M
813	P	AVS	1.25	CN-676M				CN-700M
859	Gr	AVSS	0.75	CN-772F				CN-679F
862	G/O	AVSS	0.75	CN-412F				CN-883M
864	L/G	AVSS	0.75	CN-772F				CN-679F
902	Gr/R	AVSS	0.75	CN-679F				CN-JC04F
902	Gr/R	AVSS	0.75	CN-413F				CN-JC04F
902	Gr/R	AVSS	0.75	CN-772F				CN-JC04F

No.	COLOR	TYPE	SIZE	FROM	2-WIRE CLAMP No.	CONNECTION	2-WIRE CLAMP No.	TO
903	Lg	AVSS	0.75	CN-679F				CN-JC04F
903	Lg	AVSS	0.75	CN-413F				CN-JC04F
903	Lg	AVSS	0.75	CN-772F				CN-JC04F
926	R	AVSS	0.75	CN-772F				CN-679F
927	O/W	AVSS	0.75	CN-772F				CN-679F
930	Gr/R	AVSS	0.75	CN-680M				CN-883M
931	Br/W	AVSS	0.75	CN-680M				CN-883M
944	Br	AVSS	0.75	CN-634F				CN-678M
946	O/L	AVSS	0.75	CN-413F				CN-883M
947	P/G	AVSS	0.75	CN-413F				CN-883M
986	Y/G	AVSS	0.75	CN-638F				CN-884F
987	L/O	AVSS	0.75	CN-638F				CN-677M
988	G	AVSS	0.75	CN-413F				CN-680M
989	Y/G	AVSS	0.75	CN-413F				CN-680M
A01	R	AVSS	0.75	CN-616F				CN-618F
A02	Br	AVSS	0.75	CN-616F				CN-618F
A03	B/L	AVSS	0.75	CN-616F				CN-618F
A04	G/W	AVSS	0.75	CN-616F				CN-618F
A05	Gr/R	AVSS	0.75	CN-616F				CN-618F
A06	P	AVSS	0.75	CN-616F				CN-618F
A07	Gr/L	AVSS	0.75	CN-616F				CN-618F
A08	W/G	AVSS	0.75	CN-616F				CN-618F
A09	B/R	AVSS	0.75	CN-616F				CN-618F
A10	G/L	AVSS	0.75	CN-616F				CN-618F
A11	W/Y	AVSS	0.75	CN-616F				CN-618F
A12	Gr/B	AVSS	0.75	CN-616F				CN-618F
A20	Y/G	AVSS	0.75	CN-677M				CN-614F
CO2	Y	AVSS	0.75	CN-412F				CN-883M
114H	R	AVSS	0.75	CN-673M		XXXX		CN-709M
115H	G	AVSS	0.75	CN-673M		XXXX		CN-709M
119H	Y	AVSS	0.75	CN-615F		XXXX		CN-677M
120H	L	AVSS	0.75	CN-615F		XXXX		CN-677M
372	R/Y	AVSS	0.75	CN-673M		XXXX		CN-613F
373	W/B	AVSS	0.75	CN-673M		XXXX		CN-613F
374	L/G	AVSS	0.75	CN-673M		XXXX		CN-612F
375	Br/R	AVSS	0.75	CN-673M		XXXX		CN-612F
376	O/L	AVSS	0.75	CN-611F		XXXX		CN-673M
377	Gr/L	AVSS	0.75	CN-611F		XXXX		CN-673M
494	YB	AVSS	0.75	CN-621F		XXXX		CN-884F
495	L/G	AVSS	0.75	CN-621F		XXXX		CN-884F
496	G	AVSS	0.75	CN-622F		XXXX		CN-884F
497	L/Y	AVSS	0.75	CN-622F		XXXX		CN-884F
498	R/G	AVSS	0.75	CN-623F		XXXX		CN-884F
499	L/R	AVSS	0.75	CN-623F		XXXX		CN-884F
E07	B	AVSS	0.75	LA-C9	DSC3			CN-620F
E029	B	AVSS	0.75	LA-C9	DSC3			CN-610F
E011	B	AVSS	0.75	CA-C1	DSC1			LA-C1
E026	B	AVSS	0.75	CA-C1	DSC1			CN-629F
E013	B	AVSS	1.25	CN-JC01F				LA-C7
E016	B	AVSS	0.75	CN-JC01F				CN-626F
E017	B	AVSS	0.75	CN-JC01F				CN-626F
E018	B	AVSS	0.75	CN-JC01F				CN-634F
E01P	B	AVSS	1.25	CN-JC01F				CN-JC01F
E020	B	AVSS	0.75	CN-624F				CN-JC01F
E021	B	AVSS	0.75	CN-624F				CN-JC01F
E022	B	AVSS	0.75	CN-624F				CN-JC01F
E023	B	AVSS	0.75	CN-624F				CN-JC01F
E024	B	AVSS	1.25	LA-C4				CN-JC01F
E027	B	AVSS	0.75	CN-608F			DSC6	CN-607F
E028	B	AVSS	0.75	LA-C6			DSC6	CN-607F
E1	B/W	AVSS	1.25	CN-708F				CN-672M
E2	B/W	AVSS	1.25	CN-708F				CN-672M
E3	B/W	AVSS	1.25	CN-708F				CN-672M
E4	B/W	AVSS	1.25	CN-708F				CN-672M
E5	B/W	AVSS	1.25	CN-708F				CN-672M
E8	B/W	AVSS	1.25	CN-700M				CN-614F
E9	B/W	AVSS	1.25	CN-700M				CN-614F
E10	B/W	AVSS	0.5	CN-672M				CN-708F
E11	B/W	AVSS	0.75	CN-709M				CN-679F

10. ELECTRIC SYSTEM

POWER SUPPLY HARNESS

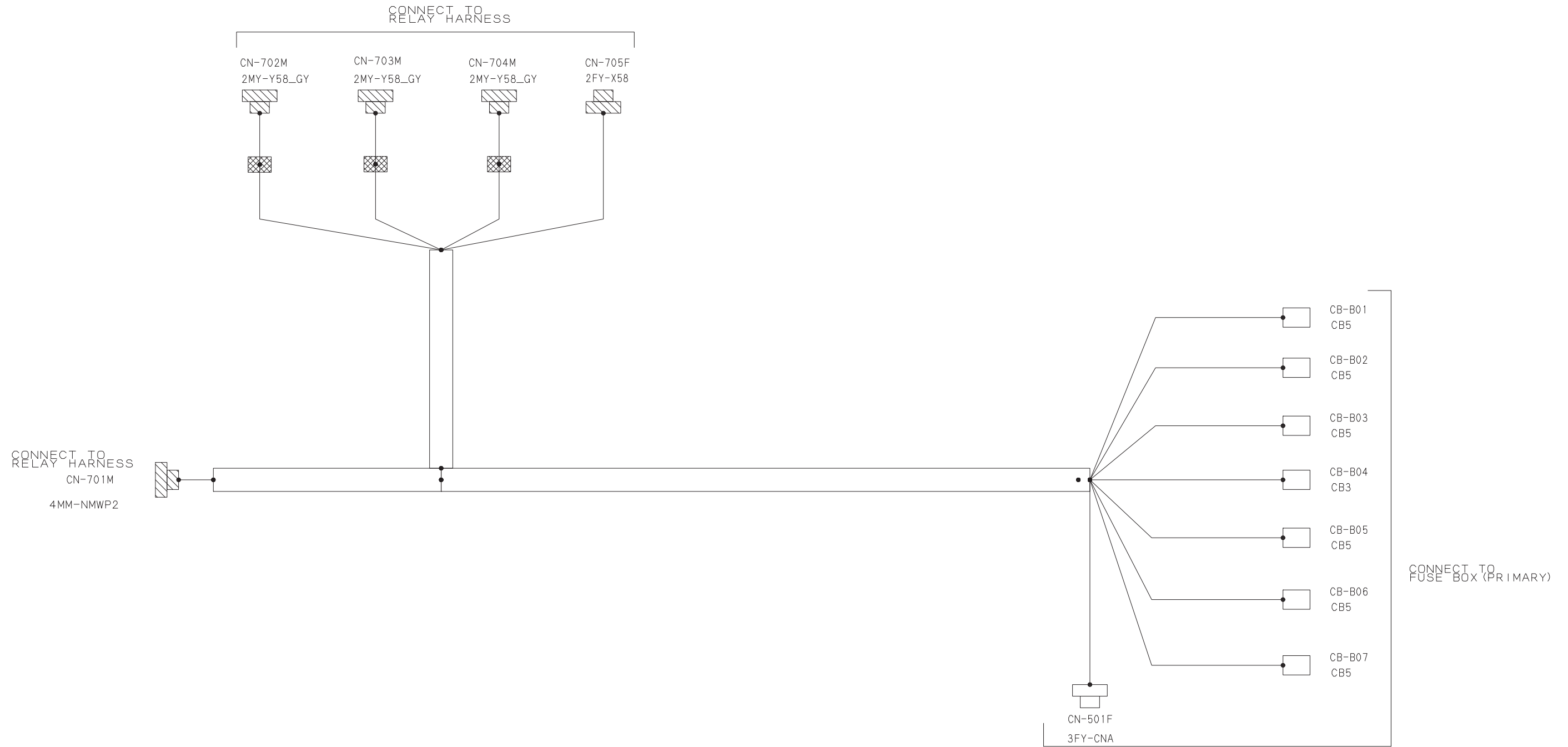

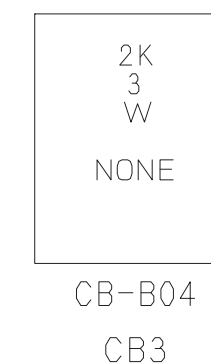
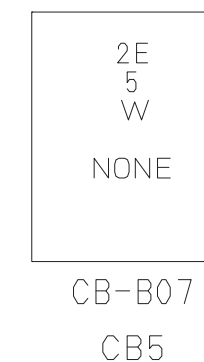
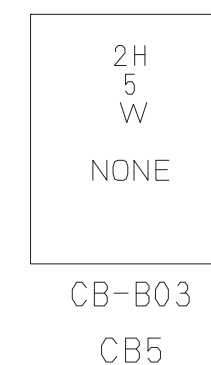
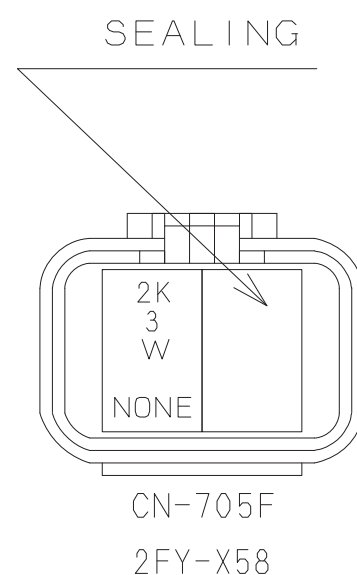
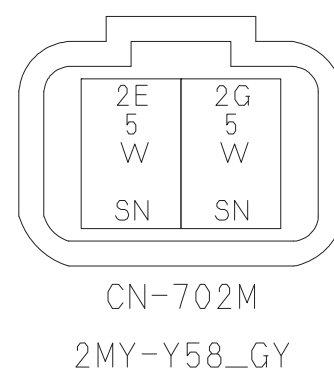
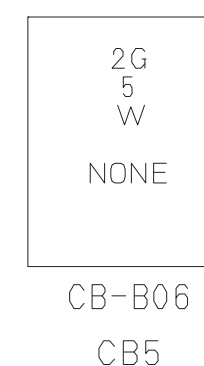
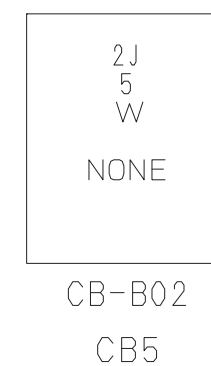
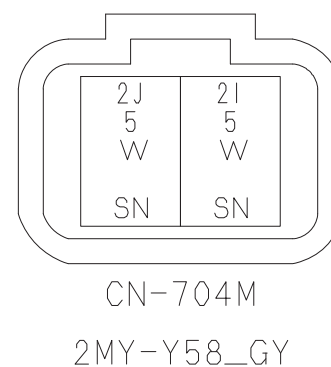
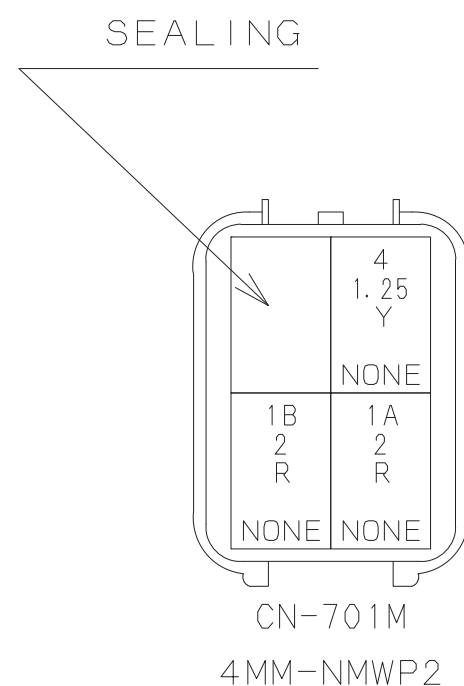
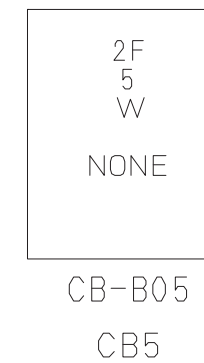
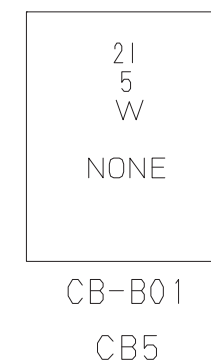
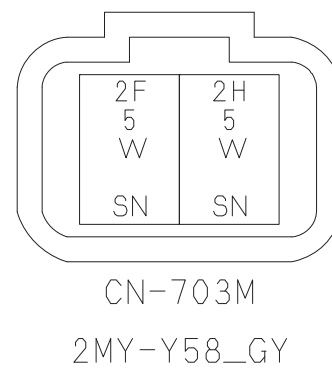
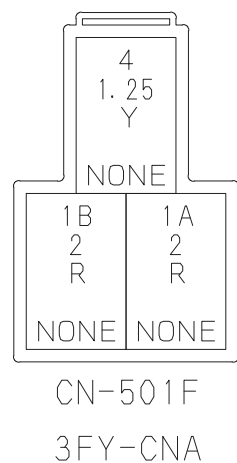

10. ELECTRIC SYSTEM

WIRE No. AND WIRE COLOR LIST

No.	COLOR	TYPE	SIZE	FROM	DISTINGUISH SYMBOL	2-WIRE CLAMP No.	CONNECTION	2-WIRE CLAMP No.	DISTINGUISH SYMBOL	TO
1A	R	AVS	2	CN-501F			=====			CN-701M
1B	R	AVS	2	CN-501F			=====			CN-701M
2E	W	AVS	5	CB-B07			=====			CN-702M
2F	W	AVS	5	CB-B05			=====			CN-703M
2G	W	AVS	5	CB-B06			=====			CN-702M
2H	W	AVS	5	CB-B03			=====			CN-703M
2I	W	AVS	5	CB-B01			=====			CN-704M
2J	W	AVS	5	CB-B02			=====			CN-704M
2K	W	AVS	3	CB-B04			=====			CN-705F
4	Y	AVSS	1.25	CN-501F			=====			CN-701M



STARTER HARNESS (TERMINAL B) TO BATTERY RELAY HARNESS

STARTER MOTOR TERMINAL B

LA-C1
60-S8

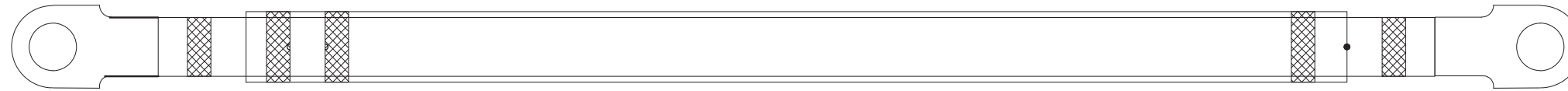

BATTERY RELAY (R-B)
LA-E12
60-8

WIRE No. AND WIRE COLOR LIST

No.	COLOR	TYPE	SIZE	FROM	DISTINGUISH SYMBOL	2-WIRE CLAMP No.	CONNECTION	2-WIRE CLAMP No.	DISTINGUISH SYMBOL	TO
2	B	AV	60	LA-E12			—————			LA-C1

10. ELECTRIC SYSTEM

STARTER HARNESS (TERMINAL C) TO SAFETY RELAY HARNESS



WIRE No. AND WIRE COLOR LIST

No.	COLOR	TYPE	SIZE	FROM	DISTINGUISH SYMBOL	2-WIRE CLAMP No.	CONNECTION	2-WIRE CLAMP No.	DISTINGUISH SYMBOL	TO
65	W	AV	8	LA-C1			—————			LA-E31

GLOW RELAY HARNESS TO ENGINE SUB HARNESS



WIRE No. AND WIRE COLOR LIST

No.	COLOR	TYPE	SIZE	FROM	DISTINGUISH SYMBOL	2-WIRE CLAMP No.	CONNECTION	2-WIRE CLAMP No.	DISTINGUISH SYMBOL	TO
A17	W	AV	8	LA-E36B			—————			CN-635F

10. ELECTRIC SYSTEM

5. ELECTRICAL PART OF RIGHT DECK (GUARD)

SOL : SOLENOID VALVE
 SW : SWITCH
 PSW : PRESSURE SWITCH
 ATT. : ATTACHMENT
 C/W : COUNTER WEIGHT
 CB/W : CARBODY WEIGHT

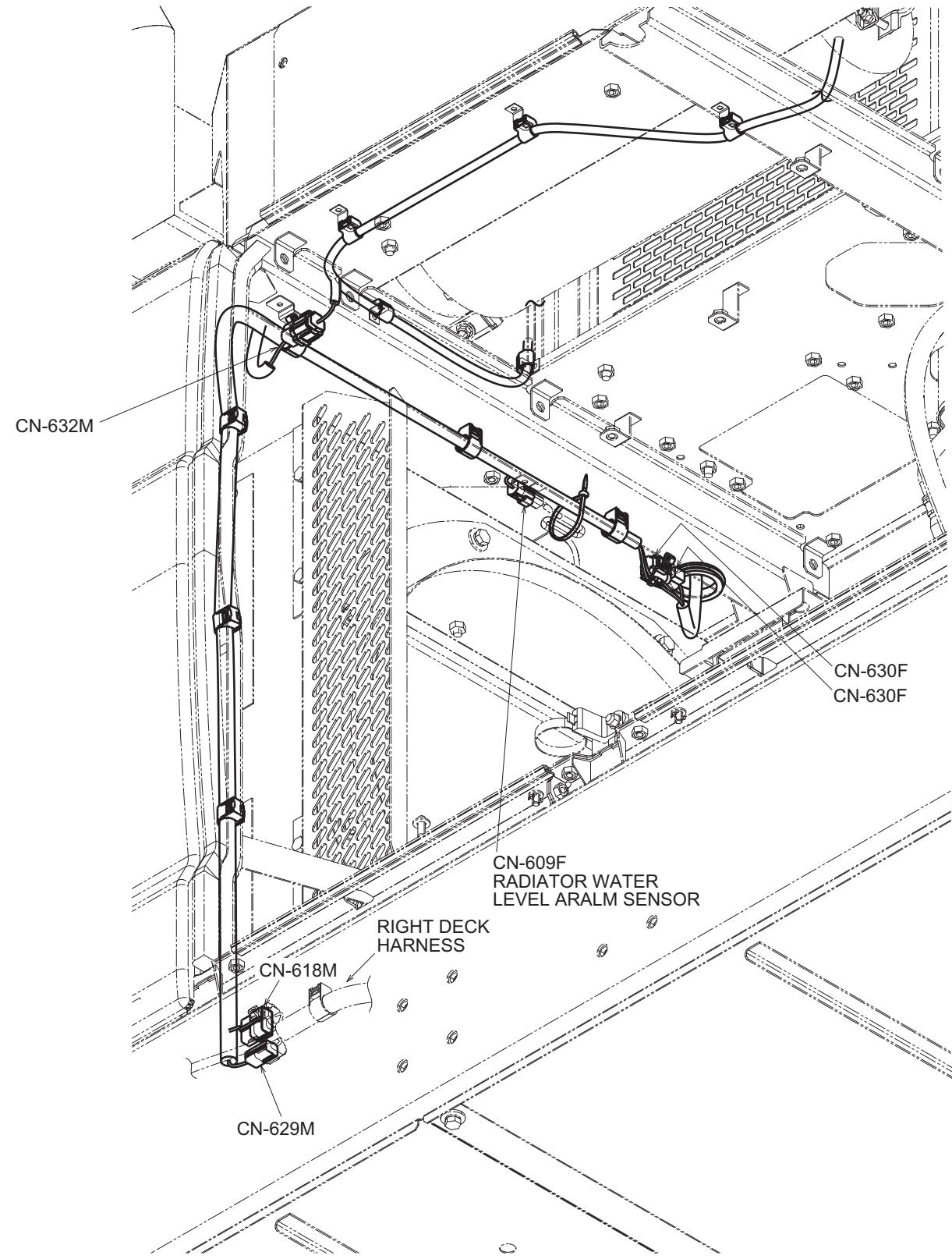

VIEW FROM "A"

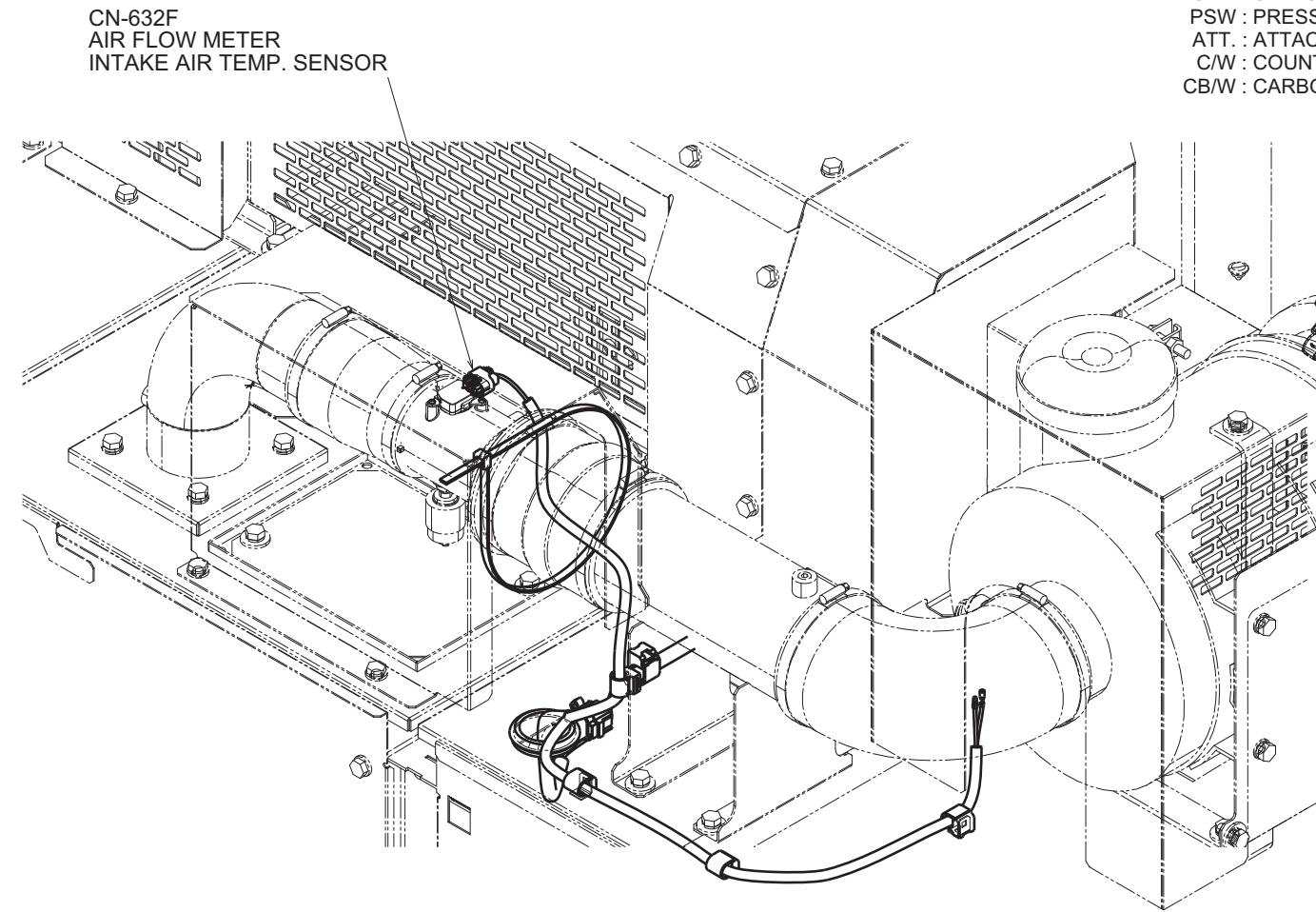

VIEW FROM "B"

SOL : SOLENOID VALVE
 SW : SWITCH
 PSW : PRESSURE SWITCH
 ATT. : ATTACHMENT
 C/W : COUNTER WEIGHT
 CB/W : CARBODY WEIGHT

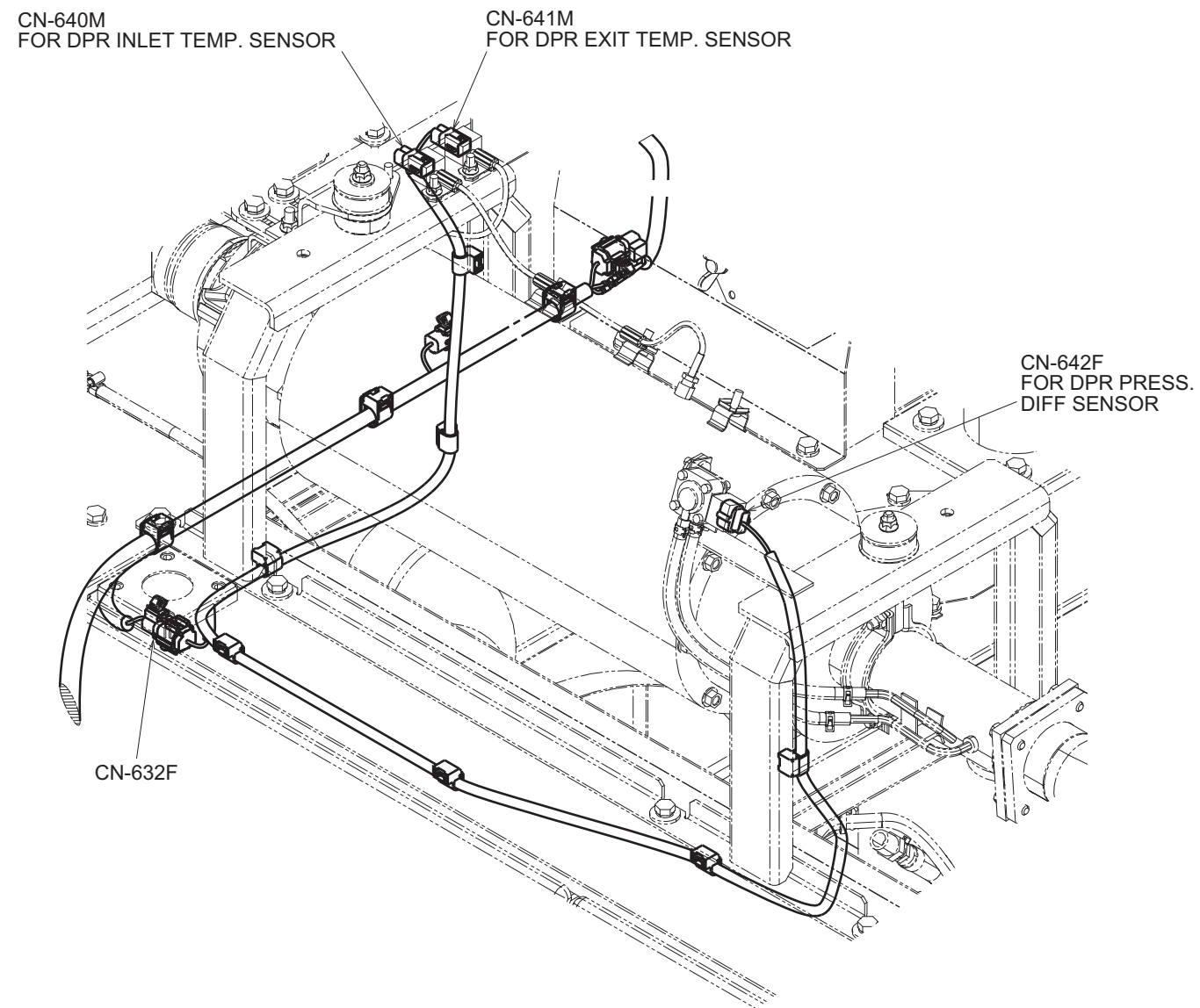

VIEW FROM "C"

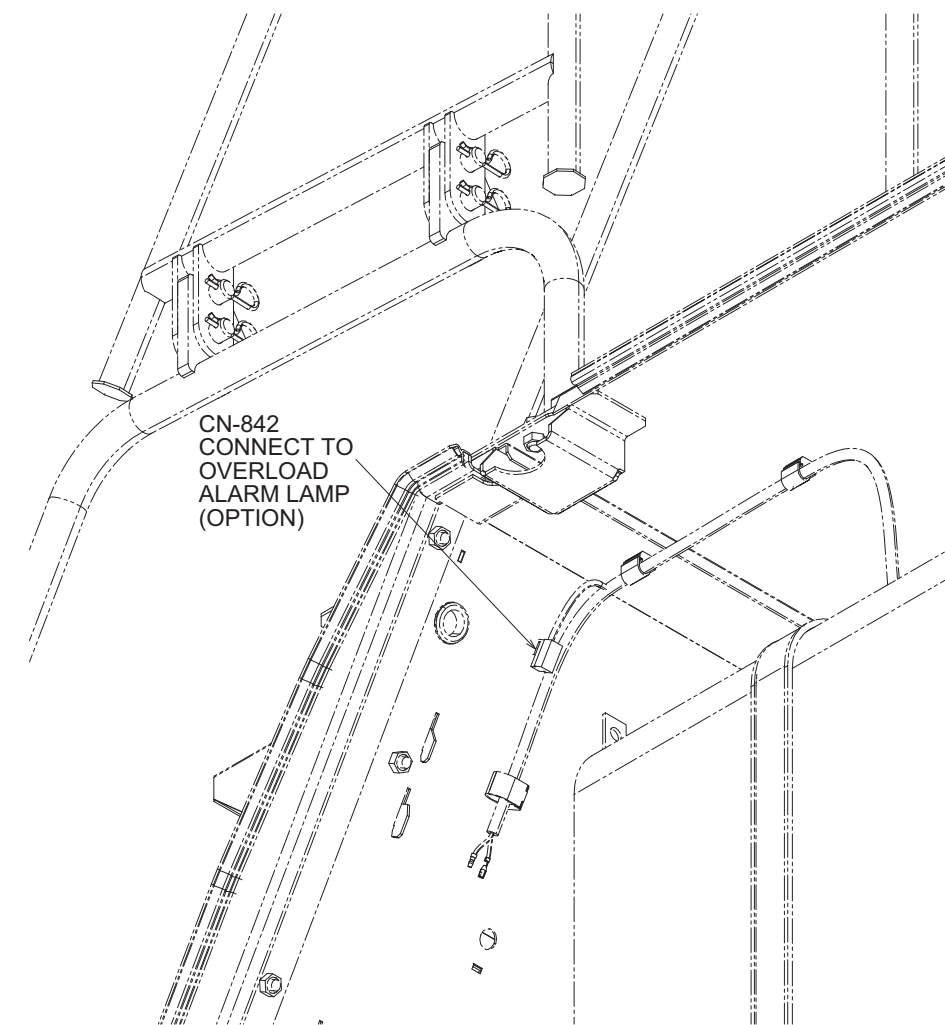

VIEW FROM "D"

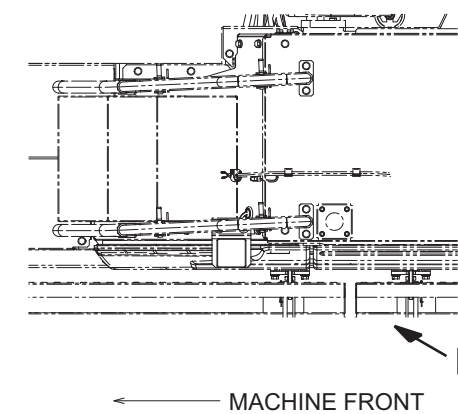
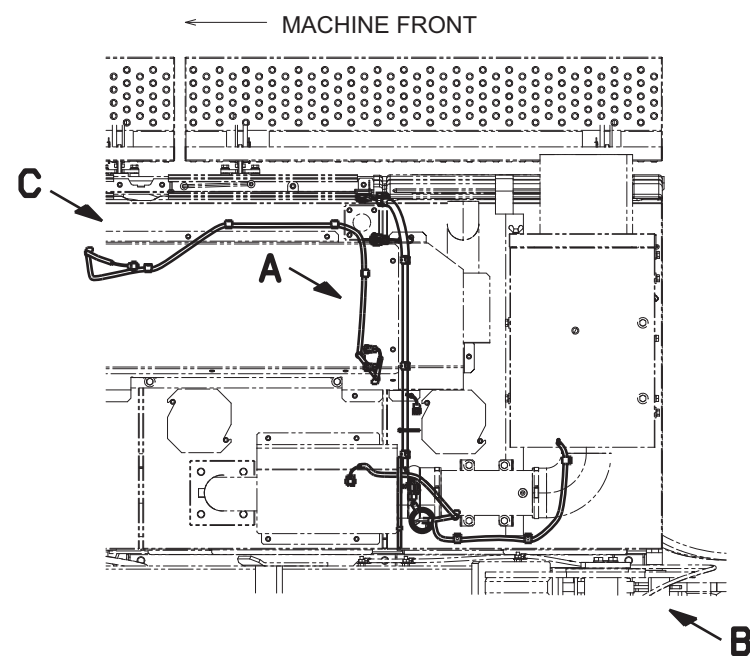

10. ELECTRIC SYSTEM

GUARD HARNESS A

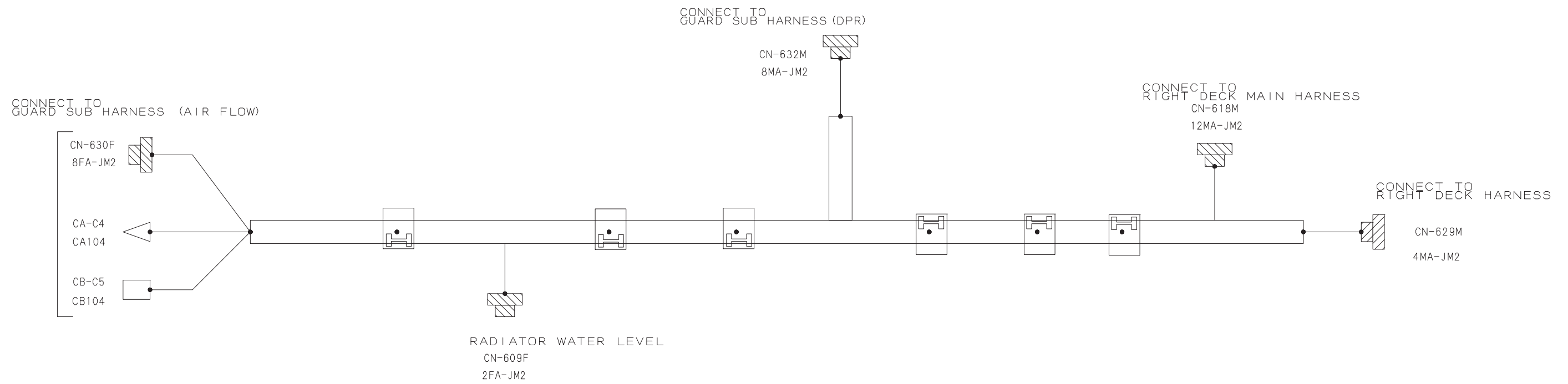

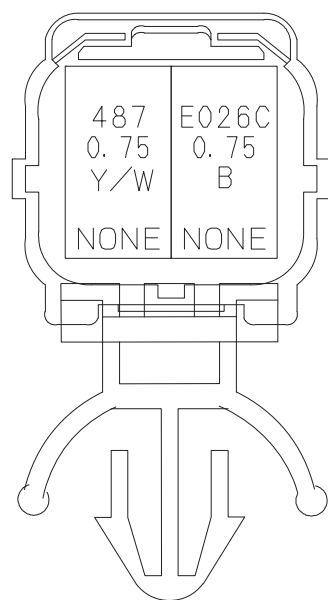

CN-609F
2FA-JM2

INSERT SEALING ON ALL EMPTY PINS

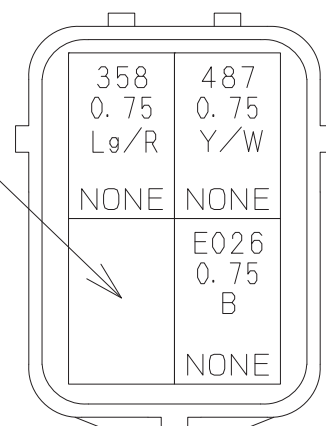

CN-629M
4MA-JM2

INSERT SEALING ON ALL EMPTY PINS

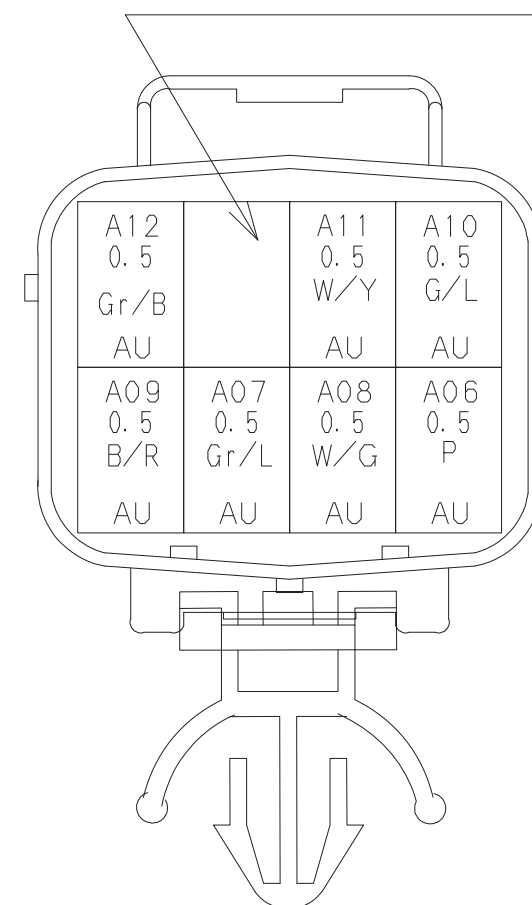

CN-632M
8MA-JM2

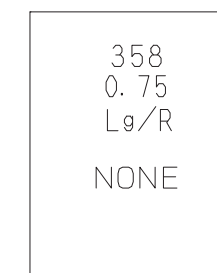

CB-C5
CB104

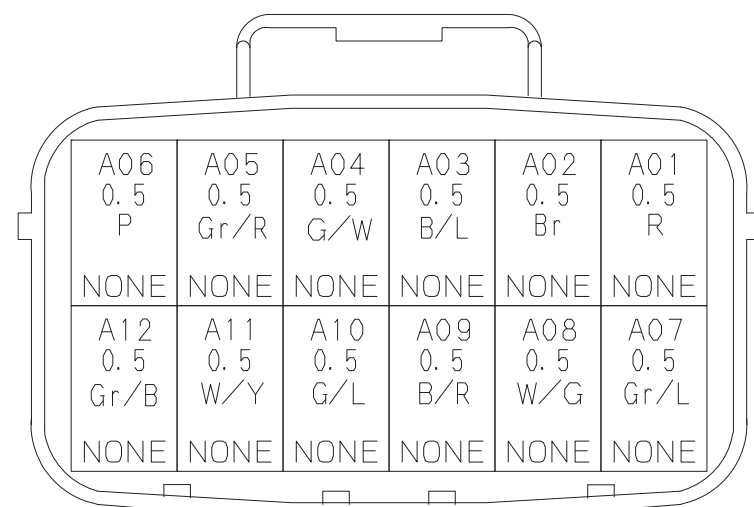

CN-618M
12MA-JM2

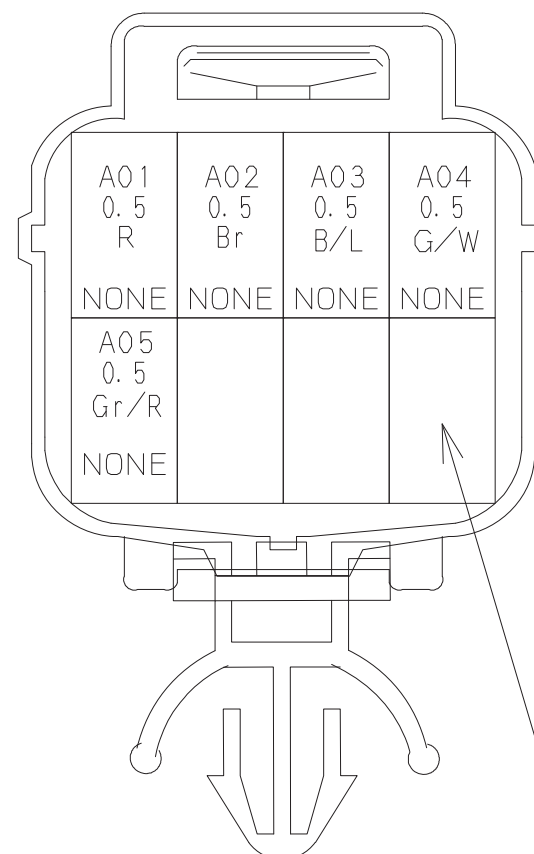

CN-630F
8FA-JM2

INSERT SEALING ON ALL EMPTY PINS

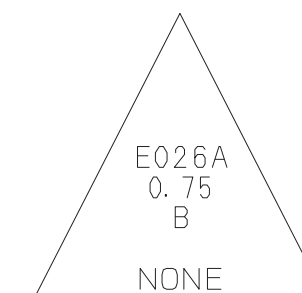

CA-C4
CA104

10. ELECTRIC SYSTEM

WIRE No. AND WIRE COLOR LIST

No.	COLOR	TYPE	SIZE	FROM	2-WIRE CLAMP No.	CONNECTION	2-WIRE CLAMP No.	T	0
358	Lg/R	AVSS	0.75	CN-629M		—————		CB-C5	
487	Y/W	AVSS	0.75	CN-609F		—————		CN-629M	
A01	R	AVSS	0.5	CN-618M		—————		CN-630F	
A02	Br	AVSS	0.5	CN-618M		—————		CN-630F	
A03	B/L	AVSS	0.5	CN-618M		—————		CN-630F	
A04	G/W	AVSS	0.5	CN-618M		—————		CN-630F	
A05	Gr/R	AVSS	0.5	CN-618M		—————		CN-630F	
A06	P	AVSS	0.5	CN-618M		—————		CN-632M	
A07	Gr/L	AVSS	0.5	CN-618M		—————		CN-632M	
A08	W/G	AVSS	0.5	CN-618M		—————		CN-632M	
A09	B/R	AVSS	0.5	CN-618M		—————		CN-632M	
A10	G/L	AVSS	0.5	CN-618M		—————		CN-632M	
A11	W/Y	AVSS	0.5	CN-618M		—————		CN-632M	
A12	Gr/B	AVSS	0.5	CN-618M		—————		CN-632M	
E026	B	AVSS	0.75	CN-629M		—————		JSC4	
E026A	B	AVSS	0.75	CA-C4		—————		JSC4	
E026C	B	AVSS	0.75	CN-609F		—————		JSC4	

GUARD HARNESS B

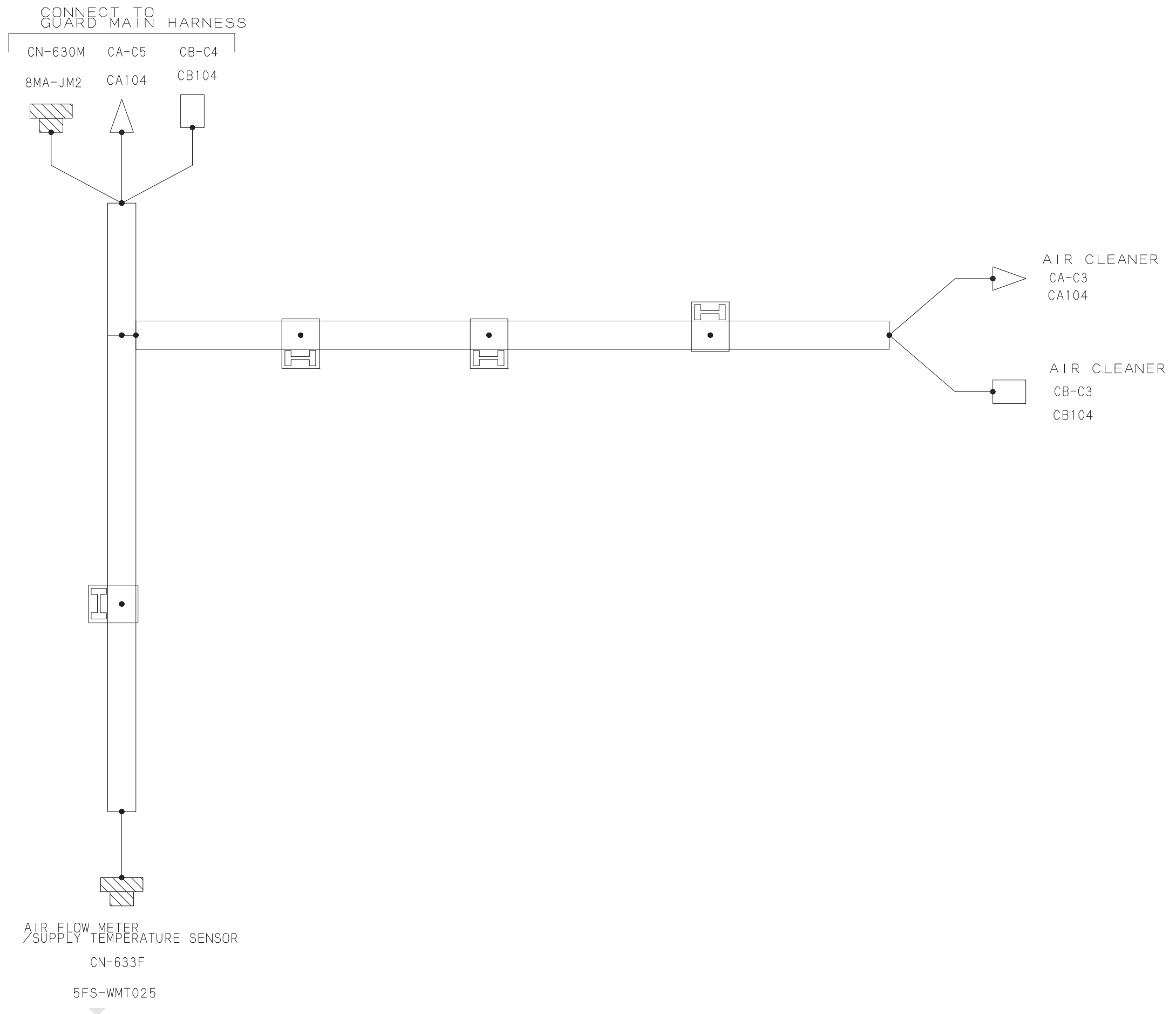

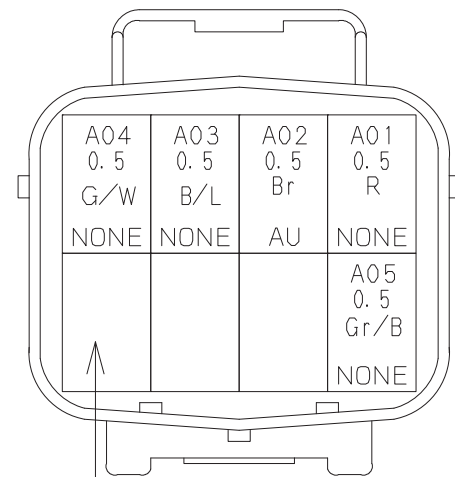

CN-630M
8MA-JM2

INSERT SEALING ON ALL EMPTY PINS

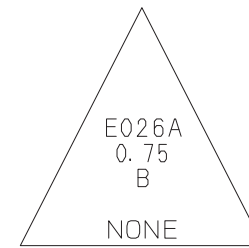

CA-C3
CA104

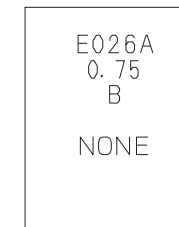

CB-C4
CB104

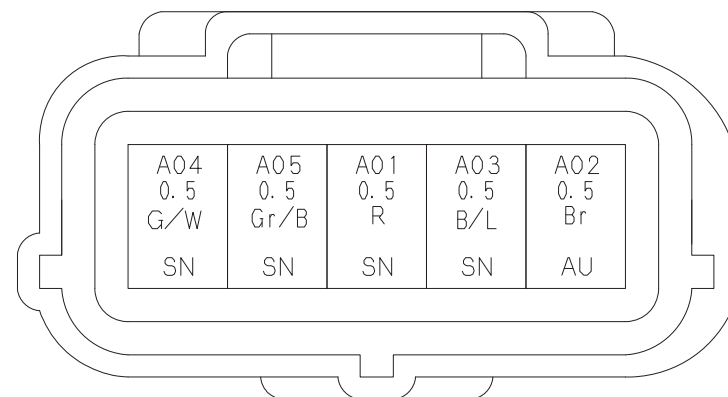

CN-633F
5FS-WMT025



CA-C5
CA104

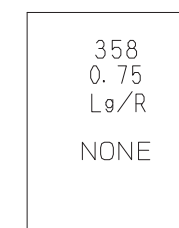

CB-C3
CB104

WIRE No. AND WIRE COLOR LIST

No.	COLOR	TYPE	SIZE	FROM	2-WIRE CLAMP No.	CONNECTION	2-WIRE CLAMP No.	TO
358	Lg/R	AVSS	0.75	CA-C5		—————		CB-C3
A01	R	AVSS	0.5	CN-630M		—————		CN-633F
A02	Br	AVSS	0.5	CN-630M		—————		CN-633F
A03	B/L	AVSS	0.5	CN-630M		—————		CN-633F
A04	G/W	AVSS	0.5	CN-630M		—————		CN-633F
A05	Gr/B	AVSS	0.5	CN-630M		—————		CN-633F
E026A	B	AVSS	0.75	CA-C3		—————		CB-C4

10. ELECTRIC SYSTEM

GUARD HARNESS C

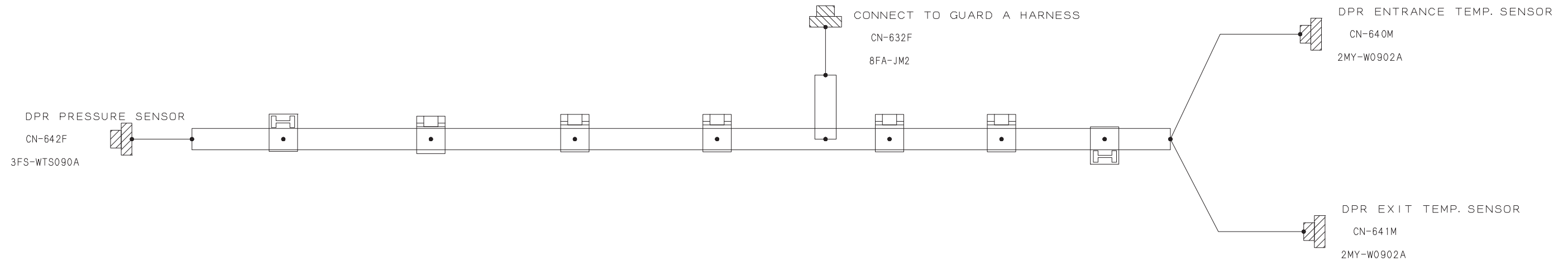

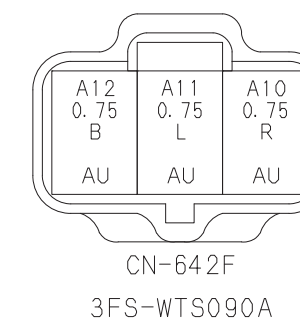
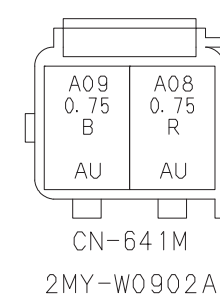
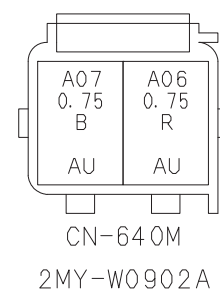
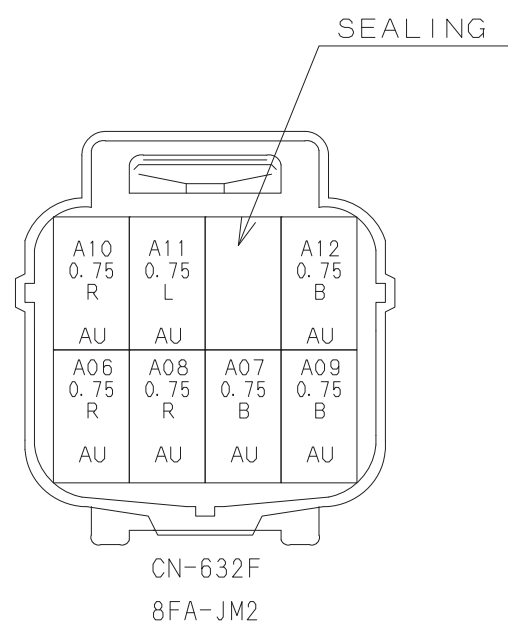

WIRE No. AND WIRE COLOR LIST

No.	COLOR	TYPE	SIZE	F R O M	PIN No.	DISTINGUISH SYMBOL	2-WIRE CLAMP No.	CONNECTION	2-WIRE CLAMP No.	DISTINGUISH SYMBOL	PIN No.	TO
A06	R	AESSX	0.75	CN-632F	5			—————			1	CN-640M
A07	B	AESSX	0.75	CN-632F	7			—————			2	CN-640M
A08	R	AESSX	0.75	CN-632F	6			—————			1	CN-641M
A09	B	AESSX	0.75	CN-632F	8			—————			2	CN-641M
A10	R	AESSX	0.75	CN-632F	1			—————			3	CN-642F
A11	L	AESSX	0.75	CN-632F	2			—————			2	CN-642F
A12	B	AESSX	0.75	CN-632F	4			—————			1	CN-642F

10. ELECTRIC SYSTEM

6. ELECTRICAL PART OF SWING FRAME

SOL : SOLENOID VALVE
 SW : SWITCH
 PSW : PRESSURE SWITCH
 ATT : ATTACHMENT
 C/W : COUNTER WEIGHT
 CB/W : CARBODY WEIGHT

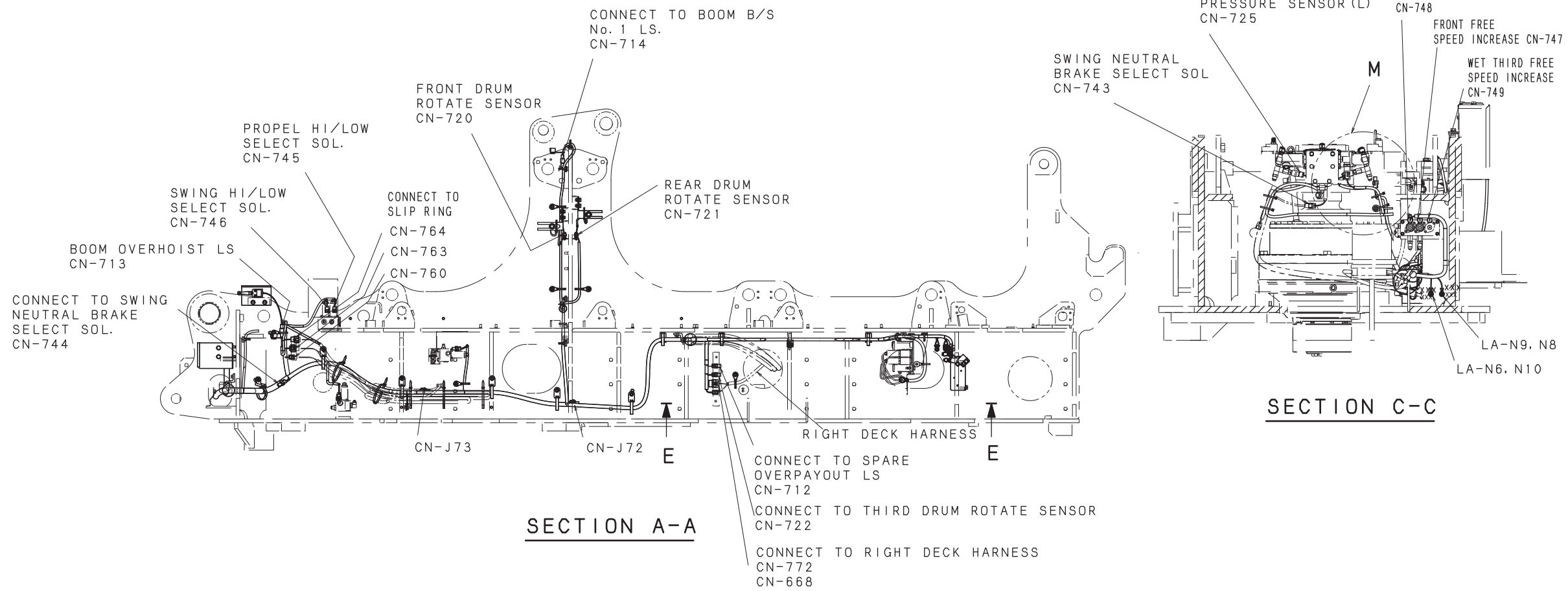
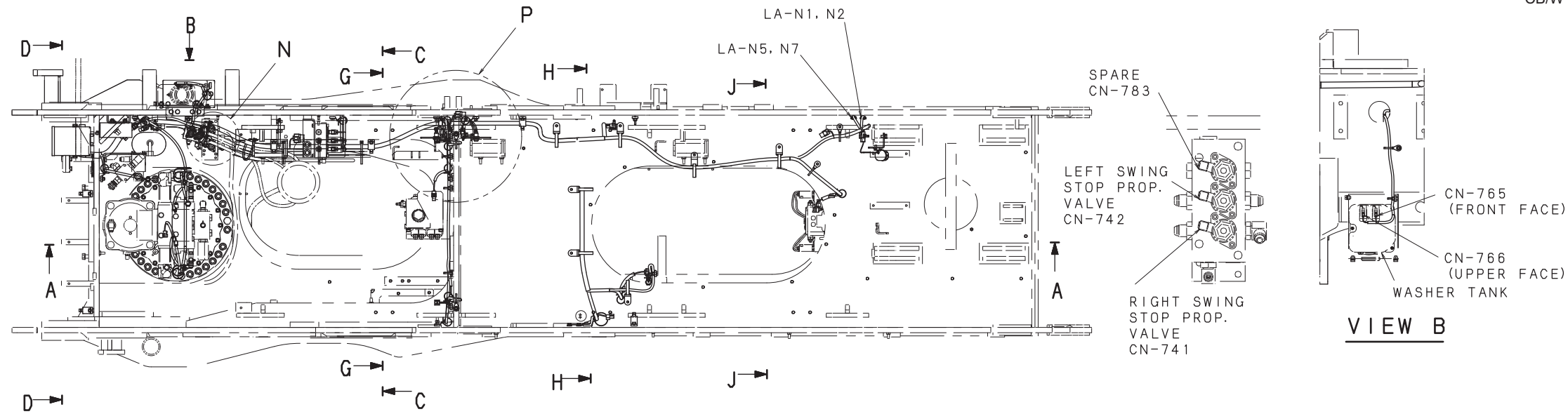

SOL : SOLENOID VALVE
 SW : SWITCH
 PSW : PRESSURE SWITCH
 ATT. : ATTACHMENT
 C/W : COUNTER WEIGHT
 CB/W : CARBODY WEIGHT

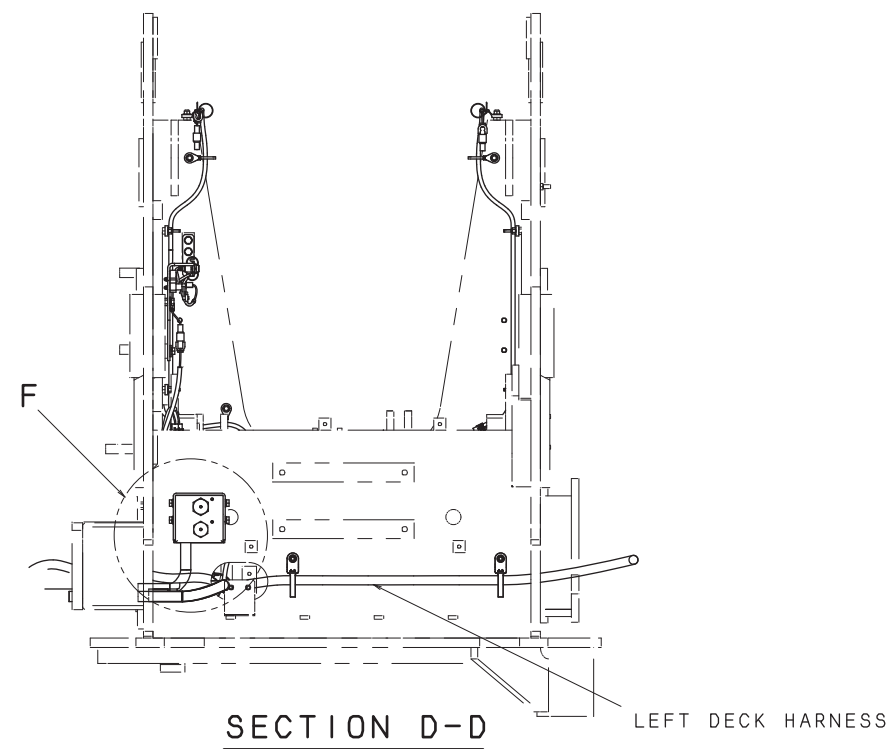
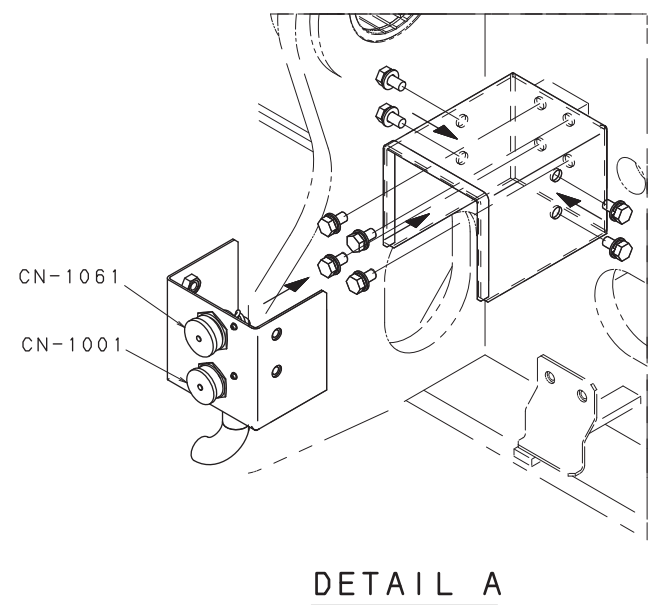
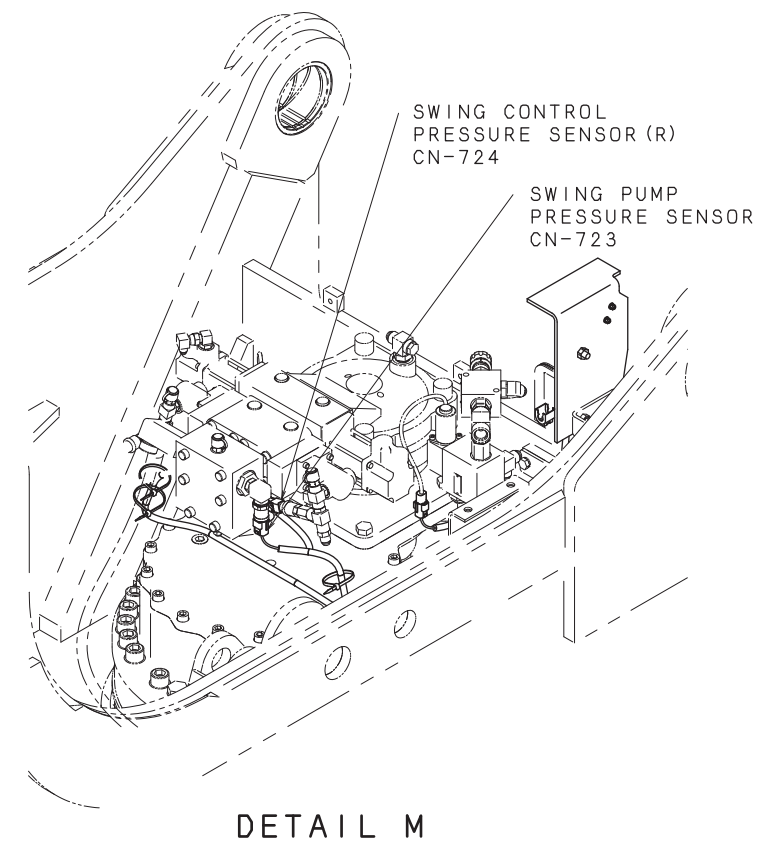
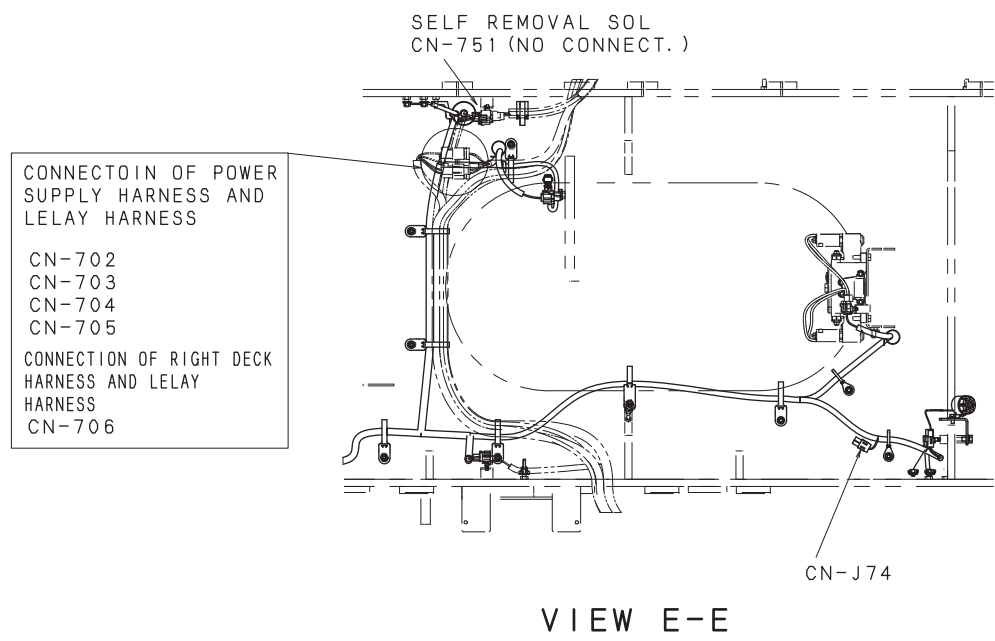

10. ELECTRIC SYSTEM

SOL : SOLENOID VALVE
 SW : SWITCH
 PSW : PRESSURE SWITCH
 ATT. : ATTACHMENT
 CW : COUNTER WEIGHT
 CBW : CARBODY WEIGHT

CONNECT TO BOOM
 B/S No. 1 LS.
 CN-714

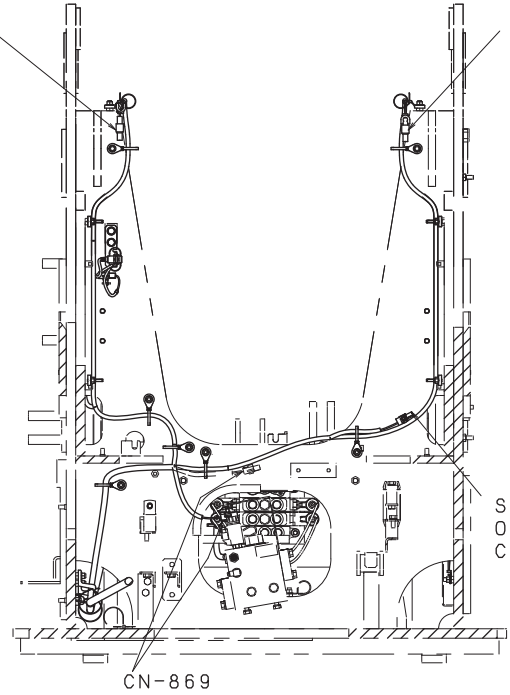

SECTION G-G

CONNECT TO BOOM
 B/S No. 2 LS.
 CN-715

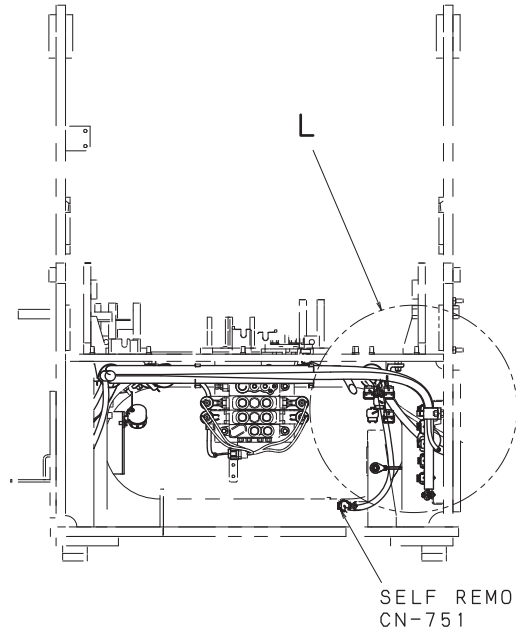

SECTION H-H

SELF REMOVAL SOL
 CN-751

REARDRUM OVERPAYOUT LS
 CN-711

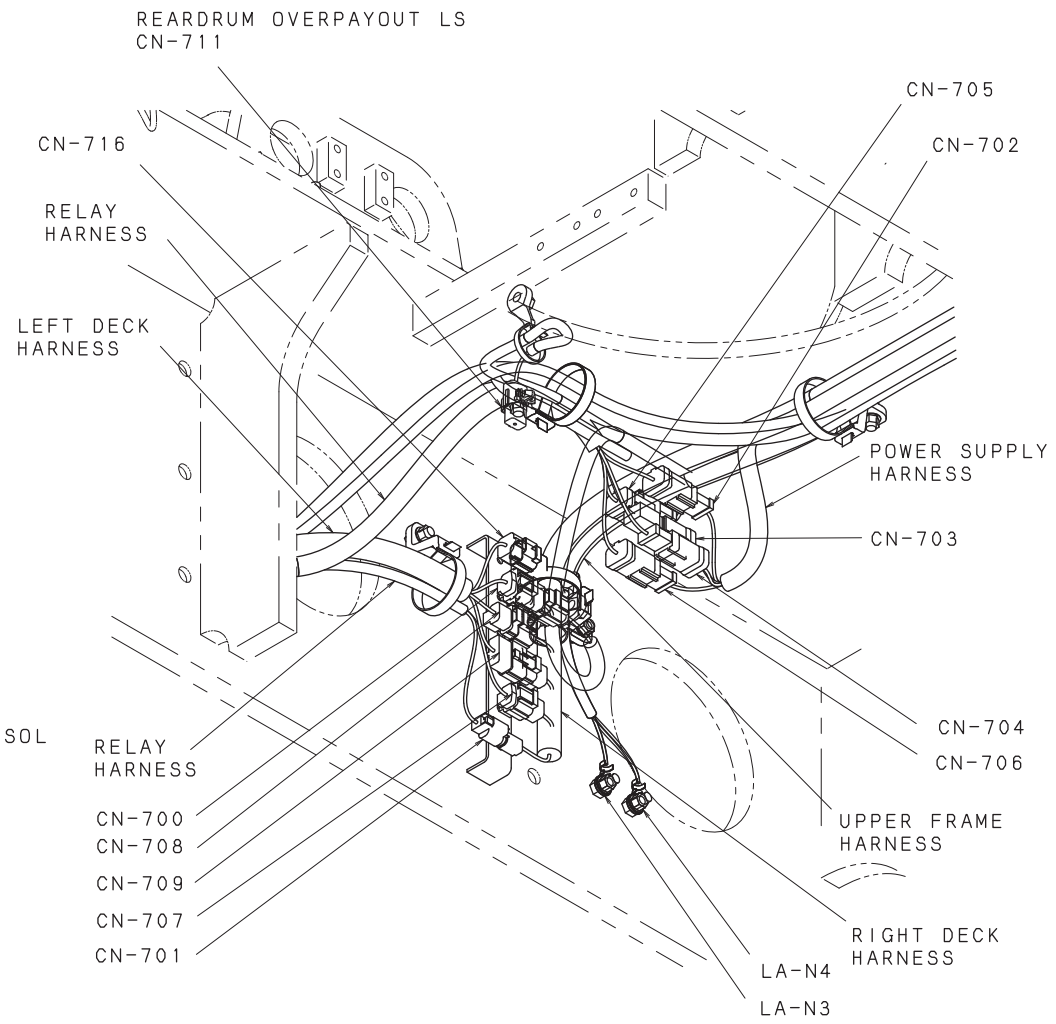

DETAIL L

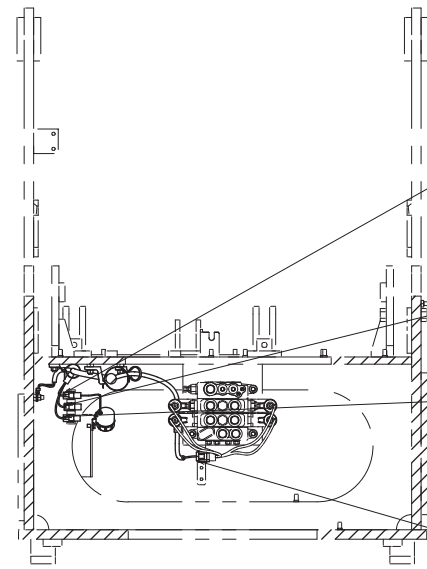

SECTION J-J

SWING BUZZER
 CN-732

VOICE ALARM
 CN-730

PROPEL BUZZER
 CN-731

HYD. SELECT GANTRY SOL.
 CN-750

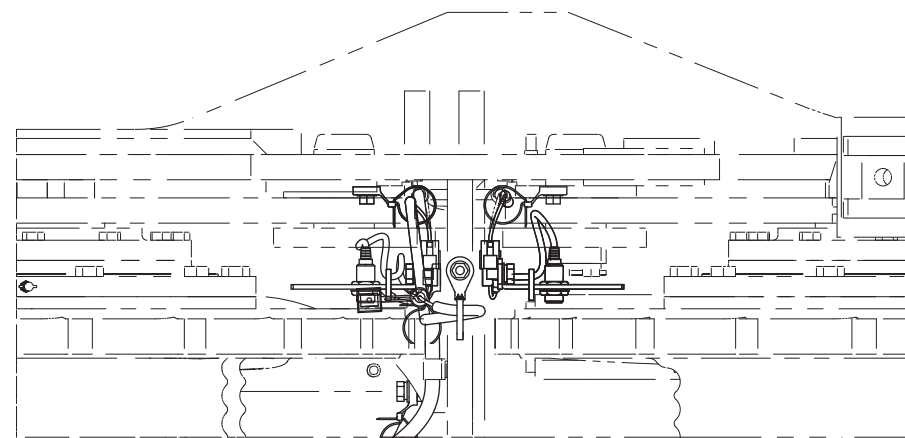

DETAIL P

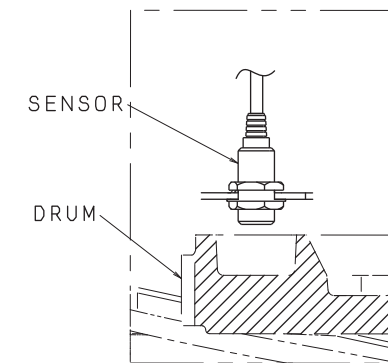

DETAIL ITEM DRUM ROTATE SENSOR

SWING FRAME HARNESS

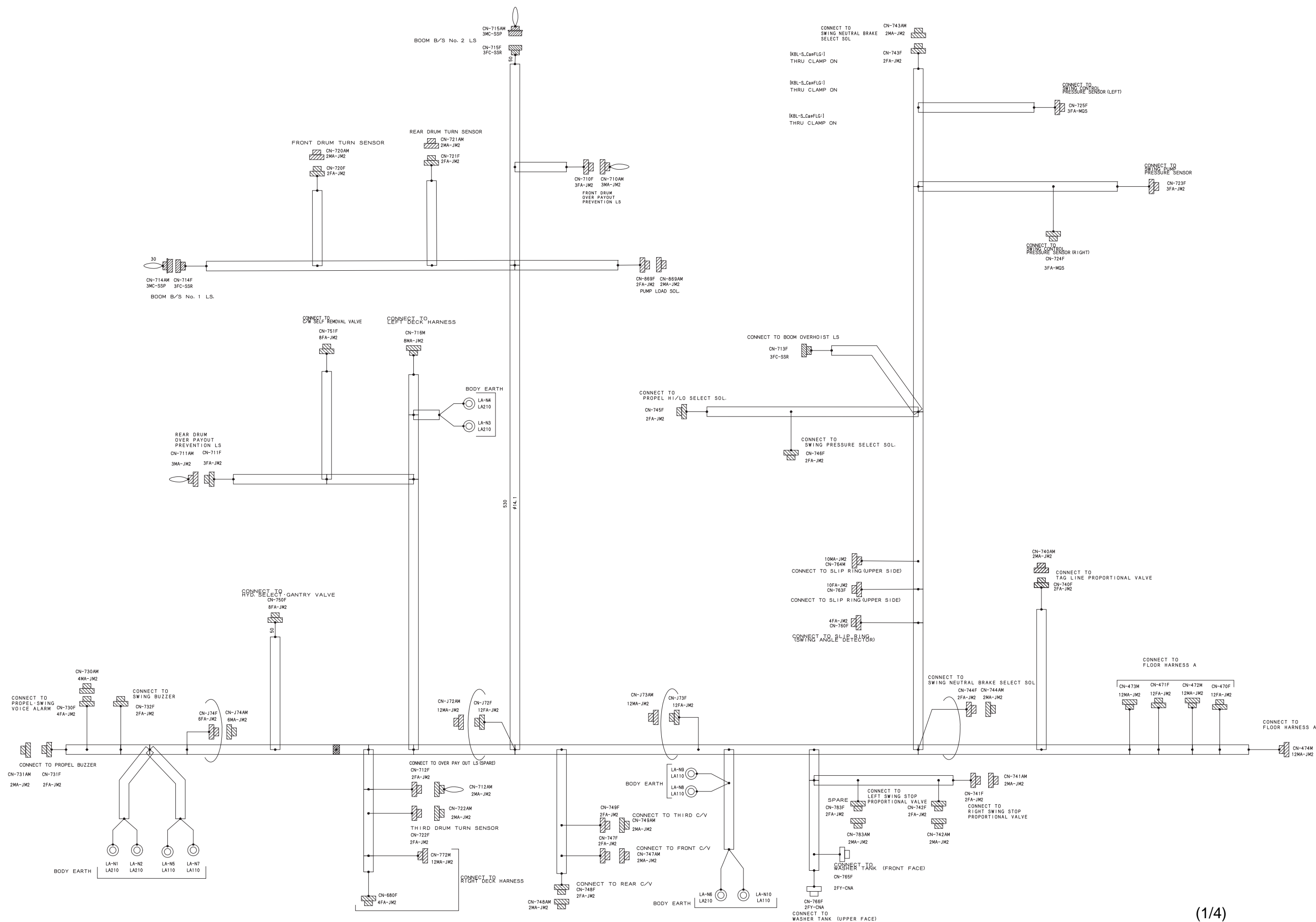

10. ELECTRIC SYSTEM

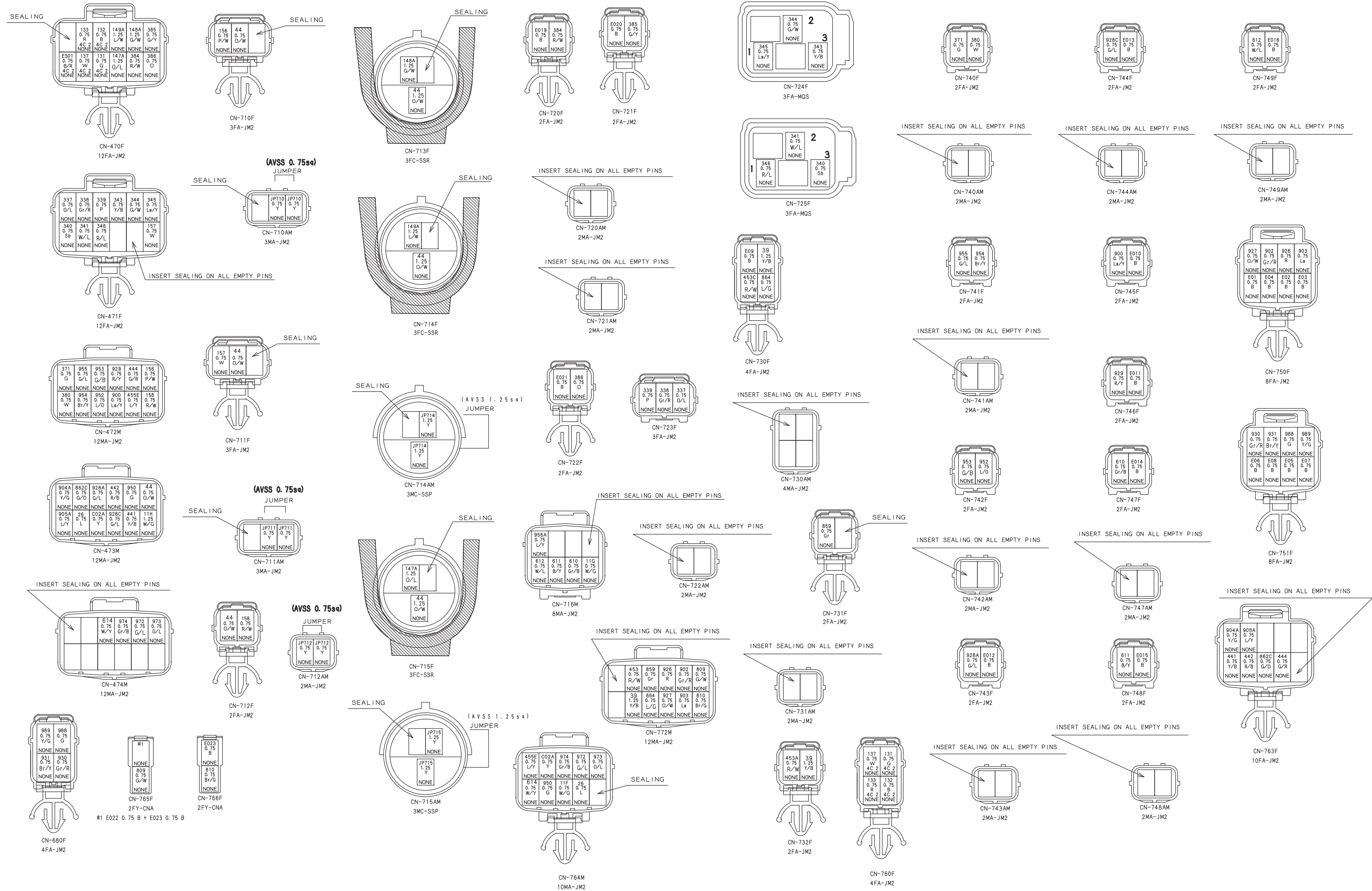

(AVSS 0.75sq)

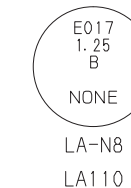
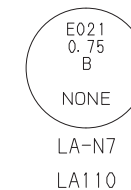
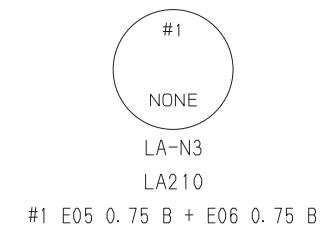
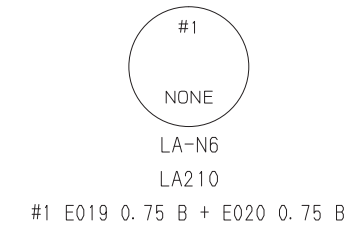
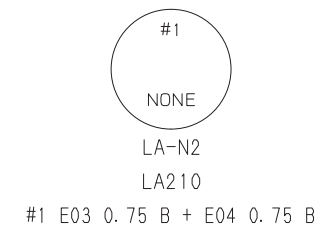
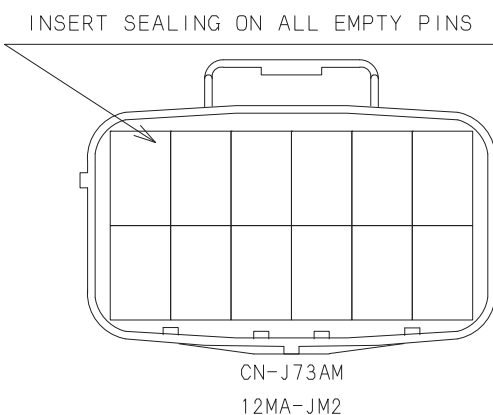
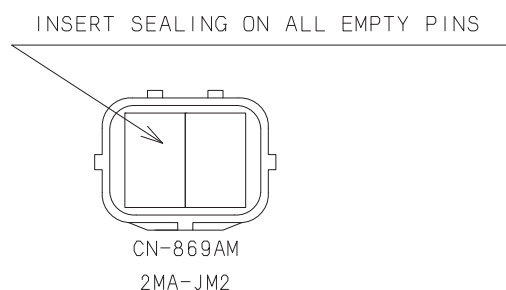
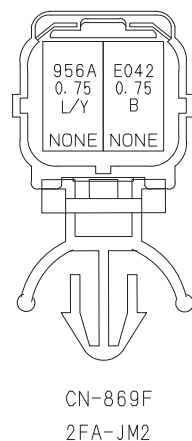
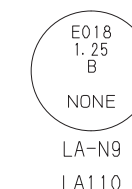
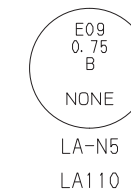
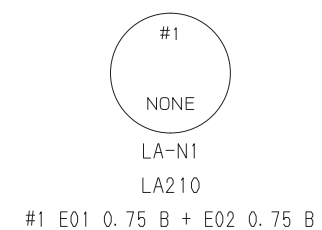
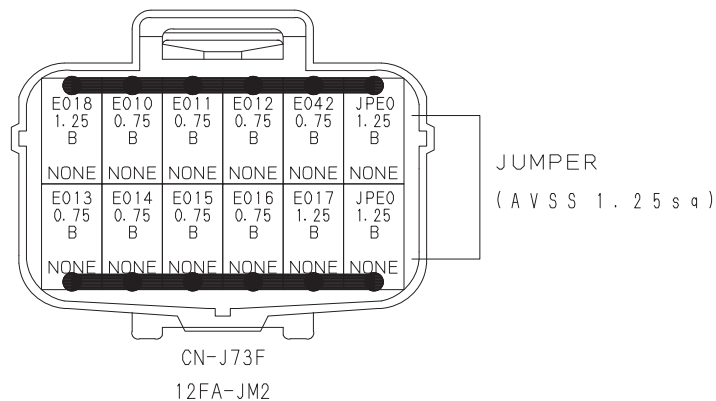
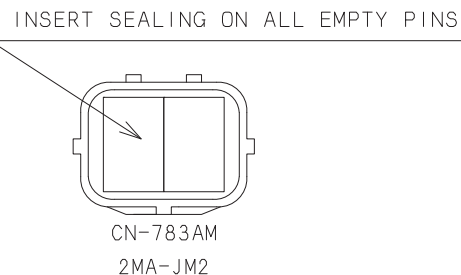
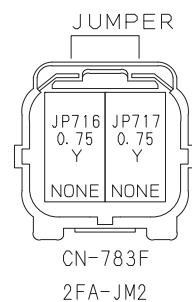

JUMPER
(AVSS 0.75sq)

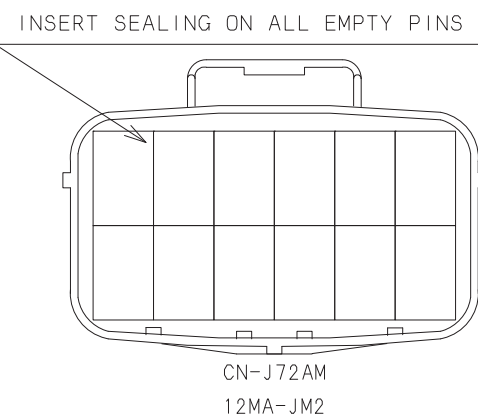
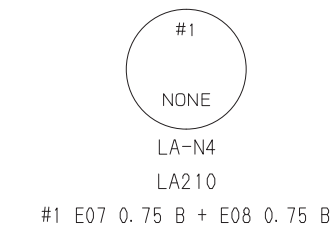
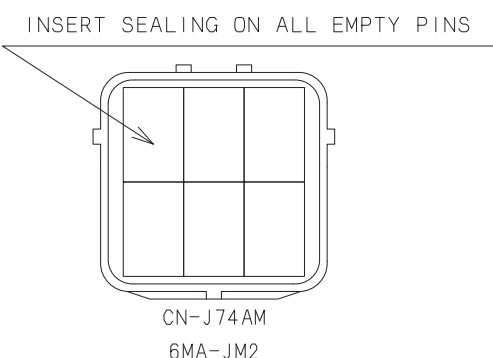
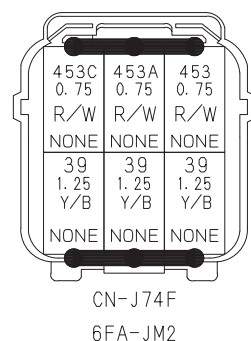
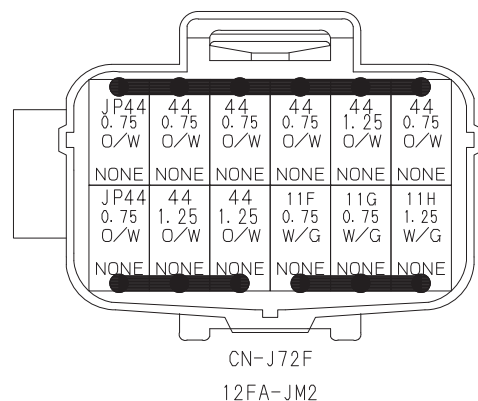

10. ELECTRIC SYSTEM

WIRE No. AND WIRE COLOR LIST

No.	COLOR	TYPE	SIZE	F R O M	2-WIRE CLAMP No.	CONNECTION	2-WIRE CLAMP No.	TO
11F	W/G	AVSS	0.75	CN-J72F				CN-764M
11G	W/G	AVSS	0.75	CN-J72F				CN-716M
11H	W/G	AVSS	1.25	CN-J72F				CN-473M
26	L	AVSS	0.75	CN-473M				CN-764M
39	Y/B	AVSS	1.25	CN-J74F				CN-772M
39	Y/B	AVSS	1.25	CN-J74F				CN-730F
39	Y/B	AVSS	1.25	CN-J74F				CN-732F
44	O/W	AVSS	0.75	CN-J72F				CN-473M
44	O/W	AVSS	0.75	CN-J72F				CN-710F
44	O/W	AVSS	0.75	CN-J72F				CN-711F
44	O/W	AVSS	0.75	CN-J72F				CN-712F
44	O/W	AVSS	1.25	CN-J72F				CN-714F
JP44	O/W	AVSS	0.75	CN-J72F				CN-J72F
44	O/W	AVSS	1.25	CN-715F				CN-J72F
44	O/W	AVSS	1.25	CN-713F				CN-J72F
147A	O/L	AVSS	1.25	CN-715F				CN-470F
148A	G/W	AVSS	1.25	CN-713F				CN-470F
149A	L/W	AVSS	1.25	CN-470F				CN-714F
156	P/W	AVSS	0.75	CN-472M				CN-710F
157	W	AVSS	0.75	CN-471F				CN-711F
158	RW	AVSS	0.75	CN-472M				CN-712F
337	O/L	AVSS	0.75	CN-723F				CN-471F
338	Gr/R	AVSS	0.75	CN-723F				CN-471F
339	P	AVSS	0.75	CN-723F				CN-471F
340	Sb	AVSS	0.75	CN-725F				CN-471F
341	W/L	AVSS	0.75	CN-725F				CN-471F
343	Y/B	AVSS	0.75	CN-724F				CN-471F
344	G/W	AVSS	0.75	CN-724F				CN-471F
345	Lg/Y	AVSS	0.75	CN-724F				CN-471F
346	R/L	AVSS	0.75	CN-725F				CN-471F
384	R/W	AVSS	0.75	CN-720F				CN-470F
385	G/Y	AVSS	0.75	CN-721F				CN-470F
386	O	AVSS	0.75	CN-470F				CN-722F
441	Y/B	AVSS	0.75	CN-473M				CN-763F
442	R/B	AVSS	0.75	CN-763F				CN-473M
444	G/R	AVSS	0.75	CN-472M				CN-763F
453	R/W	AVSS	0.75	CN-J74F				CN-772M
453A	R/W	AVSS	0.75	CN-J74F				CN-732F
453C	R/W	AVSS	0.75	CN-J74F				CN-730F
455E	L/Y	AVSS	0.75	CN-764M				CN-472M
610	Gr/B	AVSS	0.75	CN-747F				CN-716M
611	B/Y	AVSS	0.75	CN-748F				CN-716M
612	W/L	AVSS	0.75	CN-749F				CN-716M
614	W/Y	AVSS	0.75	CN-764M				CN-474M
809	G/W	AVSS	0.75	CN-772M				CN-765F
810	Br/G	AVSS	0.75	CN-766F				CN-772M
859	Gr	AVSS	0.75	CN-772M				CN-731F
862C	G/O	AVSS	0.75	CN-763F				CN-473M
864	L/G	AVSS	0.75	CN-730F				CN-772M
900	Lg/Y	AVSS	0.75	CN-745F				CN-472M
902	Gr/R	AVSS	0.75	CN-750F				CN-772M
903	Lg	AVSS	0.75	CN-750F				CN-772M
904A	Y/G	AVSS	0.75	CN-763F				CN-473M
905A	L/Y	AVSS	0.75	CN-473M				CN-763F
926	R	AVSS	0.75	CN-772M				CN-750F
927	O/W	AVSS	0.75	CN-772M				CN-750F
928A	G/L	AVSS	0.75	CN-473M				CN-743F
928C	G/L	AVSS	0.75	CN-473M				CN-744F
929	R/Y	AVSS	0.75	CN-472M				CN-746F
930	Gr/R	AVSS	0.75	CN-680F				CN-751F
931	Br/Y	AVSS	0.75	CN-680F				CN-751F
950	G	AVSS	0.75	CN-764M				CN-473M
956A	L/Y	AVSS	0.75	CN-869F				CN-716M
972	G/L	AVSS	0.75	CN-474M				CN-764M
973	O/L	AVSS	0.75	CN-474M				CN-764M
974	Gr/B	AVSS	0.75	CN-474M				CN-764M
988	G	AVSS	0.75	CN-751F				CN-680F
989	Y/G	AVSS	0.75	CN-751F				CN-680F
C02A	Y	AVSS	0.75	CN-473M				CN-764M
JP710	Y	AVSS	0.75	CN-710AM				CN-710AM
JP711	Y	AVSS	0.75	CN-711AM				CN-711AM
JP712	Y	AVSS	0.75	CN-712AM				CN-712AM
JP714	Y	AVSS	1.25	CN-714AM				CN-714AM
JP715	Y	AVSS	1.25	CN-715AM				CN-715AM
JP716	Y	AVSS	0.75	CN-783F				
JP717	Y	AVSS	0.75					CN-783F
371	G	AVSS	0.75	CN-472M				CN-740F
380	W	AVSS	0.75	CN-472M				CN-740F
952	L/O	AVSS	0.75	CN-472M				CN-742F
953	G/B	AVSS	0.75	CN-472M				CN-742F
954	Br/Y	AVSS	0.75	CN-472M				CN-741F
955	G/L	AVSS	0.75	CN-472M				CN-741F

No.	COLOR	TYPE	SIZE	F R O M	2-WIRE CLAMP No.	CONNECTION	2-WIRE CLAMP No.	TO
131	G	MVVS	0.75	CN-470F				CN-760F
132	B	MVVS	0.75	CN-470F				CN-760F
133	R	MVVS	0.75	CN-470F				CN-760F
137	W	MVVS	0.75	CN-470F				CN-760F
ES1	B/R	AVSS	0.75	CN-470F				(CN-760F)
E01	B	AVSS	0.75	CN-750F			DS01	LA-N1
E02	B	AVSS	0.75	CN-750F			DS01	LA-N1
E03	B	AVSS	0.75	LA-N2	DS02			CN-750F
E04	B	AVSS	0.75	LA-N2	DS02			CN-750F
E05	B	AVSS	0.75	CN-751F			DS03	LA-N3
E06	B	AVSS	0.75	CN-751F			DS03	LA-N3
E07	B	AVSS	0.75	LA-N4	DS04			CN-751F
E08	B	AVSS	0.75	LA-N4	DS04			CN-751F
E09	B	AVSS	0.75	CN-730F				LA-N5
E018	B	AVSS	1.25	CN-J73F				LA-N9
E010	B	AVSS	0.75	CN-J73F				CN-745F
E011	B	AVSS	0.75	CN-J73F				CN-746F
E012	B	AVSS	0.75	CN-J73F				CN-743F
E042	B	AVSS	0.75	CN-J73F				CN-869F
JPE0	B	AVSS	1.25	CN-J73F				CN-J73F
E013	B	AVSS	0.75	CN-744F				CN-J73F
E014	B	AVSS	0.75	CN-747F				CN-J73F
E015	B	AVSS	0.75	CN-748F				CN-J73F
E016	B	AVSS	0.75	CN-749F				CN-J73F
E017	B	AVSS	1.25	LA-N8				CN-J73F
E019	B	AVSS	0.75	CN-720F			DS06	LA-N6
E020	B	AVSS	0.75	CN-721F			DS06	LA-N6
E021	B	AVSS	0.75	LA-N7				CN-722F
E022	B	AVSS	0.75	CN-765F	DS07			LA-N10
E023	B	AVSS	0.75	CN-765F	DS07			CN-766F

ATT. JUNCTION HARNESS



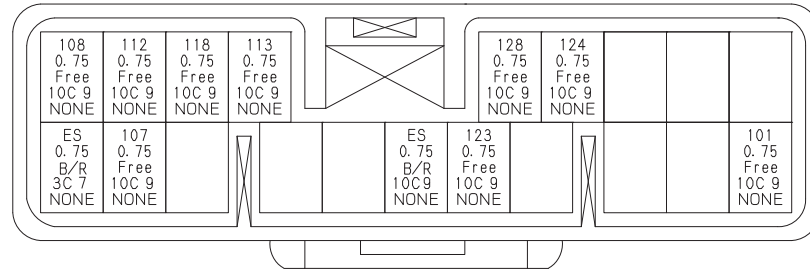

CN-298M
20MA-070ML1

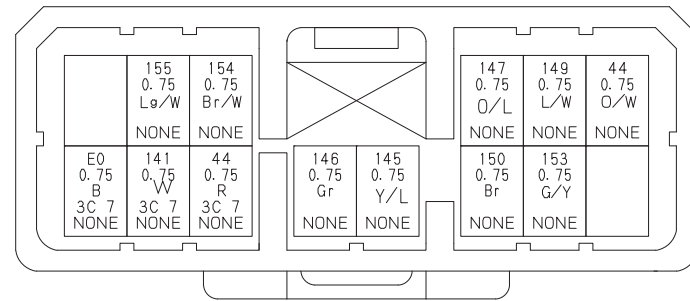

CN-299M
14MA-070ML1

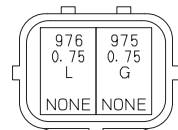

CN-888M
2MA-JM2

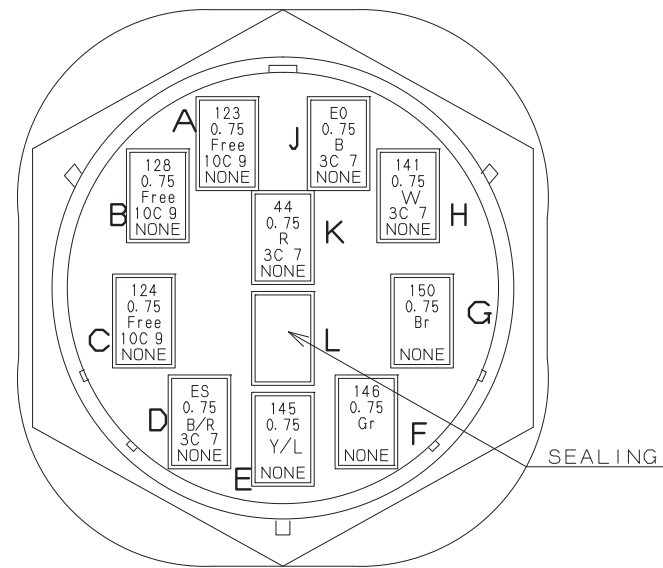



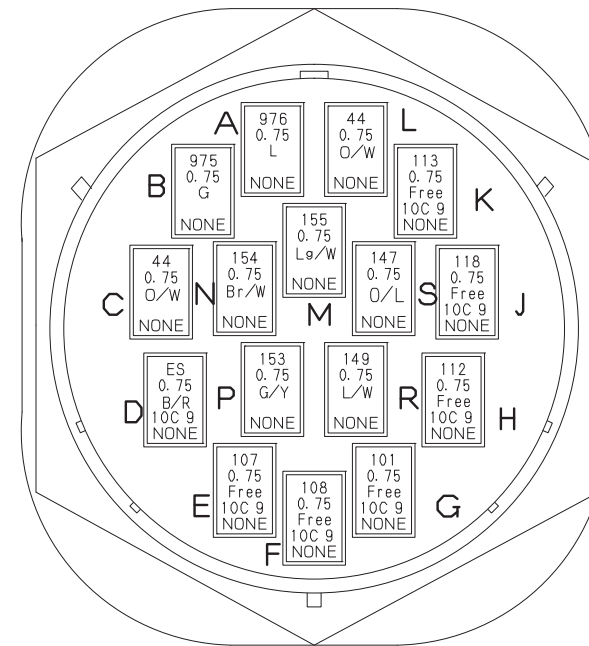



CN-1001F
11FAE-774R16+C

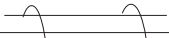

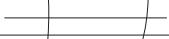
CN-1061F
16FAE-774R16+C

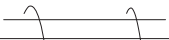
WIRE No. AND WIRE COLOR LIST

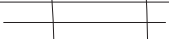
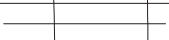
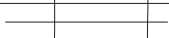
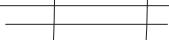
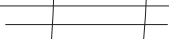
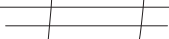
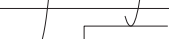
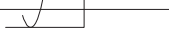
No.	COLOR	TYPE	SIZE	F R O M	PIN No.	DISTINGUISH SYMBOL	2-WIRE CLAMP No.	CONNECTION	2-WIRE CLAMP No.	DISTINGUISH SYMBOL	PIN No.	TO
44	O/W	AVSS	0.75	CN-299M	1			_____				JS
44	O/W	AVSS	0.75	CN-1061F	11			_____				JS
44	O/W	AVSS	0.75	CN-1061F	3			_____				JS
145	Y/L	AVSS	0.75	CN-1001F	5			_____			10	CN-299M
146	Gr	AVSS	0.75	CN-1001F	6			_____			11	CN-299M
147	O/L	AVSS	0.75	CN-1061F	16			_____			3	CN-299M
149	L/W	AVSS	0.75	CN-1061F	15			_____			2	CN-299M
150	Br	AVSS	0.75	CN-1001F	7			_____			9	CN-299M
153	G/Y	AVSS	0.75	CN-1061F	14			_____			8	CN-299M
154	Br/W	AVSS	0.75	CN-1061F	13			_____			4	CN-299M
155	Lg/W	AVSS	0.75	CN-1061F	12			_____			5	CN-299M
975	G	AVSS	0.75	CN-1061F	2			_____			1	CN-888M
976	L	AVSS	0.75	CN-1061F	1			_____			2	CN-888M
44	R	MVVS	0.75	CN-1001F	10	3C7				3C7	12	CN-299M
141	W	MVVS	0.75	CN-1001F	8	3C7				3C7	13	CN-299M
E0	B	MVVS	0.75	CN-1001F	9	3C7				3C7	14	CN-299M
ES	B/R	AVSS	0.75	(CN-1001F)		3C7				3C7	20	CN-298M
ES	B/R	AVSS	0.75	CN-1001F	4	3C7				3C7		(CN-299M)
101	Free	MVVS	0.75	CN-1061F	7	10C9				10C9	10	CN-298M
107	Free	MVVS	0.75	CN-1061F	5	10C9				10C9	19	CN-298M
108	Free	MVVS	0.75	CN-1061F	6	10C9				10C9	9	CN-298M
112	Free	MVVS	0.75	CN-1061F	8	10C9				10C9	8	CN-298M
113	Free	MVVS	0.75	CN-1061F	10	10C9				10C9	6	CN-298M
118	Free	MVVS	0.75	CN-1061F	9	10C9				10C9	7	CN-298M
123	Free	MVVS	0.75	CN-1001F	1	10C9				10C9	14	CN-298M
124	Free	MVVS	0.75	CN-1001F	3	10C9				10C9	4	CN-298M
128	Free	MVVS	0.75	CN-1001F	2	10C9				10C9	5	CN-298M
ES	B/R	AVSS	0.75	(CN-1061F)		10C9				10C9	15	CN-298M
ES	B/R	AVSS	0.75	CN-1061F	4	10C9				10C9		(CN-298M)

10. ELECTRIC SYSTEM

7. ELECTRICAL PART OF CAB

SOL : SOLENOID VALVE
 SW : SWITCH
 PSW : PRESSURE SWITCH
 ATT. : ATTACHMENT
 C/W : COUNTER WEIGHT
 CB/W : CARBODY WEIGHT

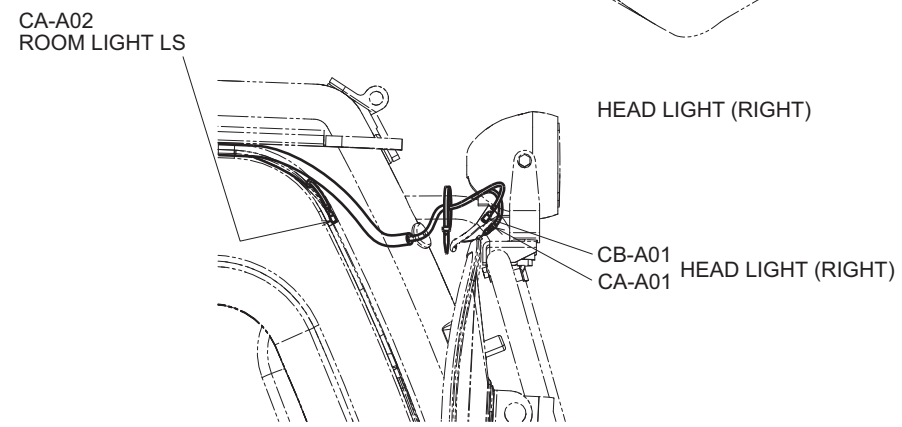
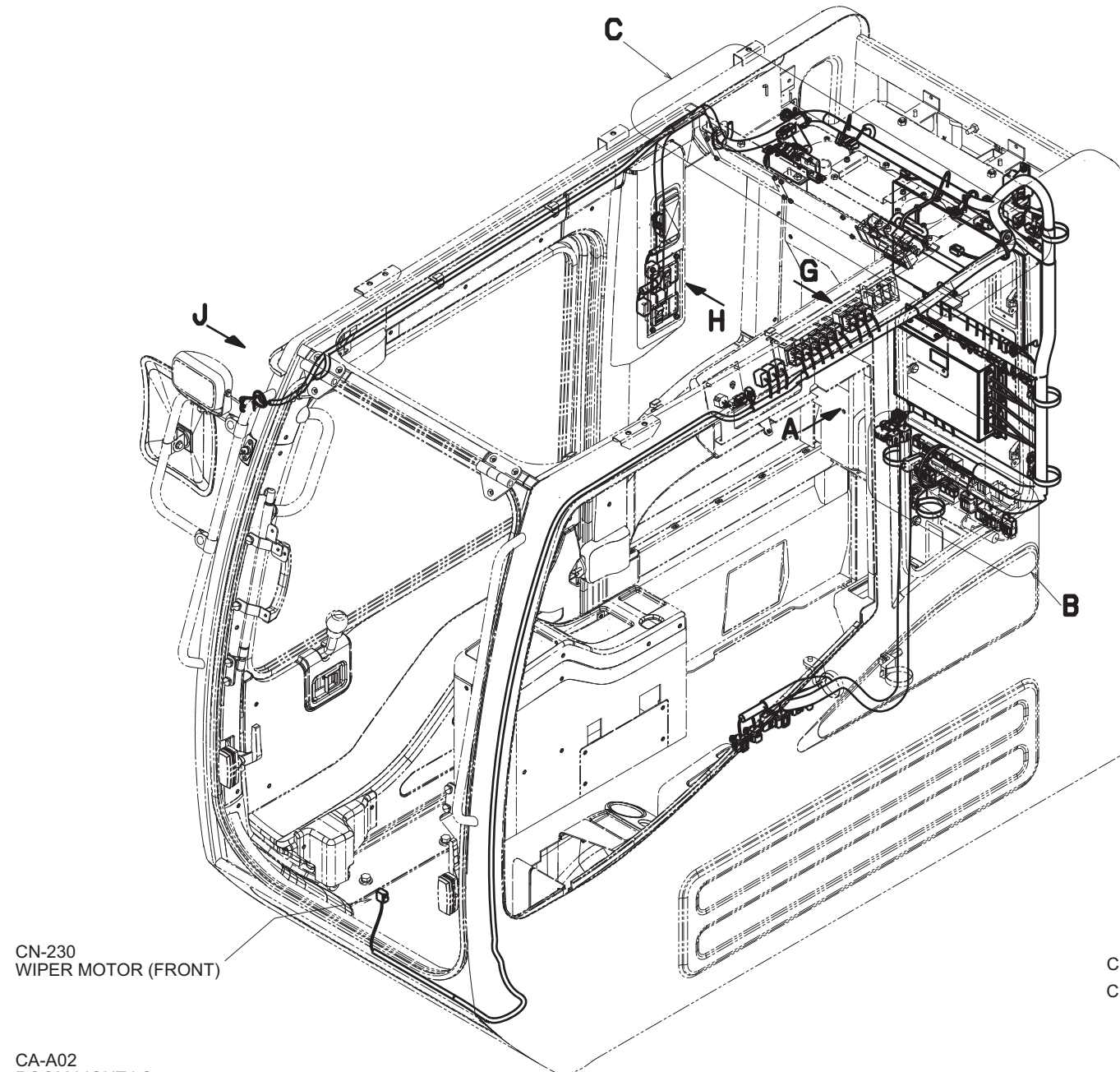

VIEW FROM "J-J"

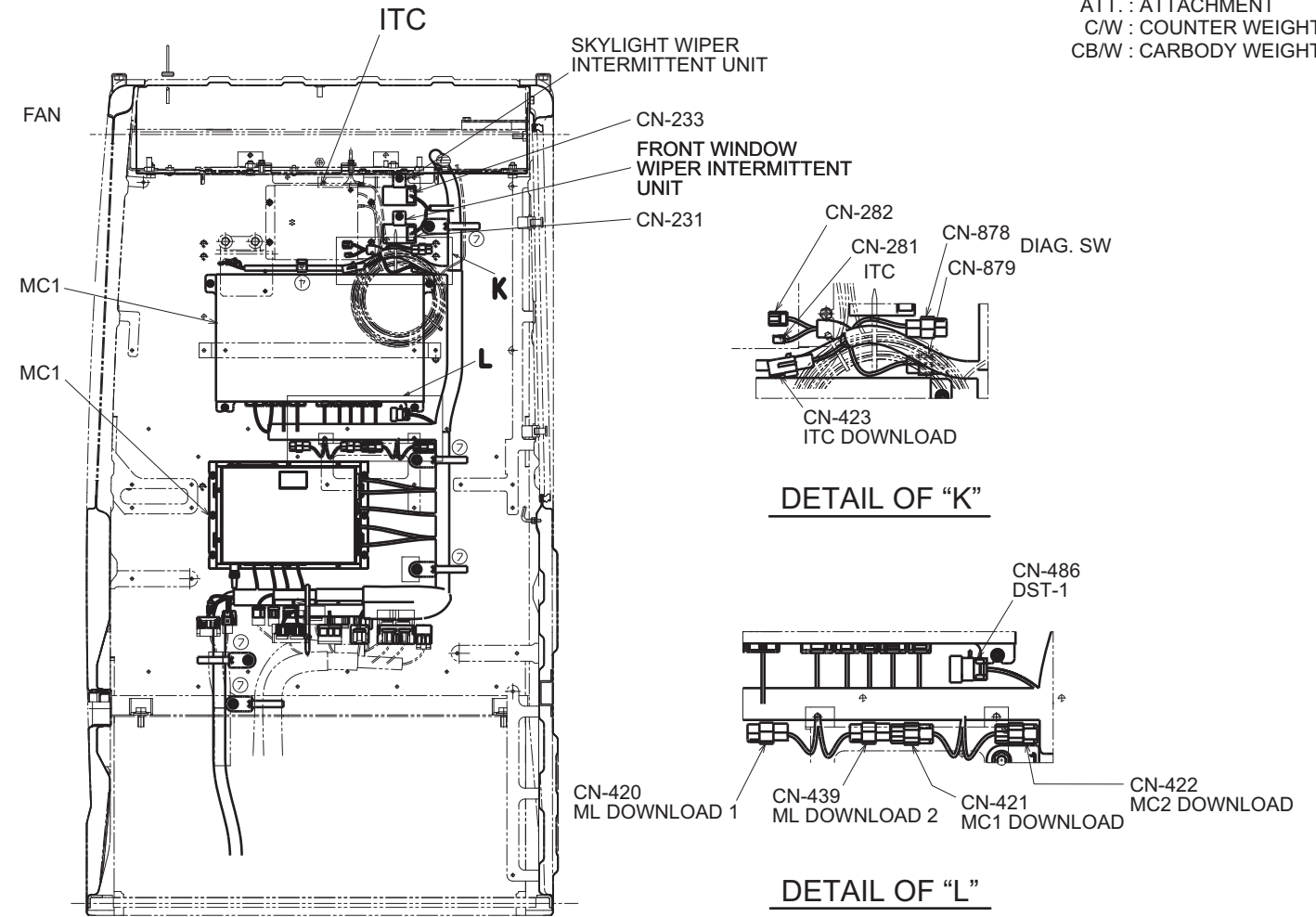

VIEW FROM "A"

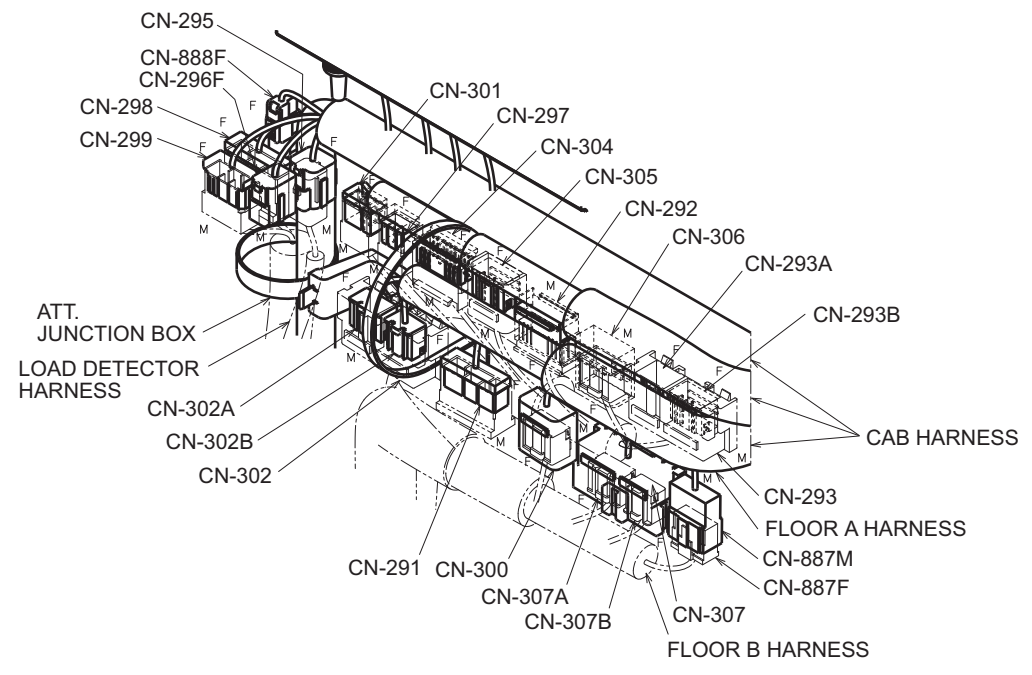

DETAIL OF "B"

SOL : SOLENOID VALVE
 SW : SWITCH
 PSW : PRESSURE SWITCH
 ATT. : ATTACHMENT
 C/W : COUNTER WEIGHT
 CB/W : CARBODY WEIGHT

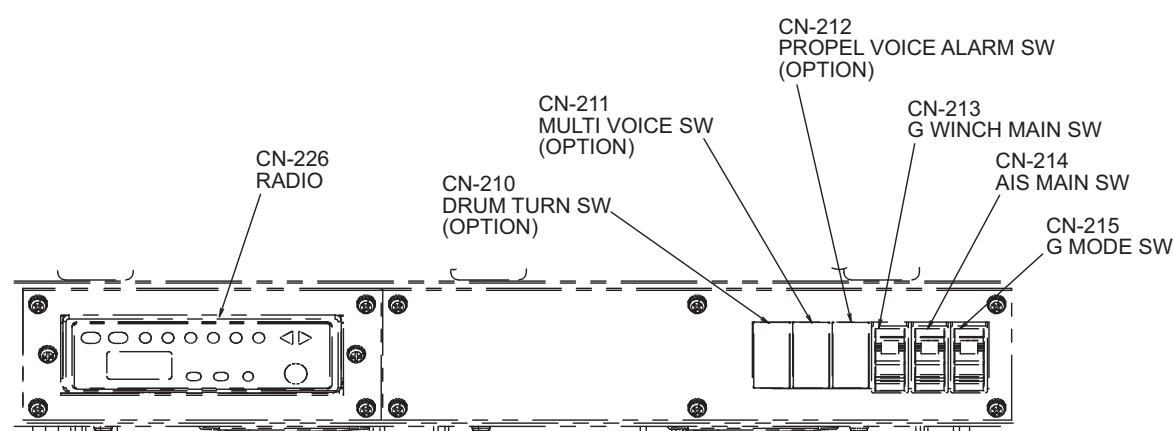
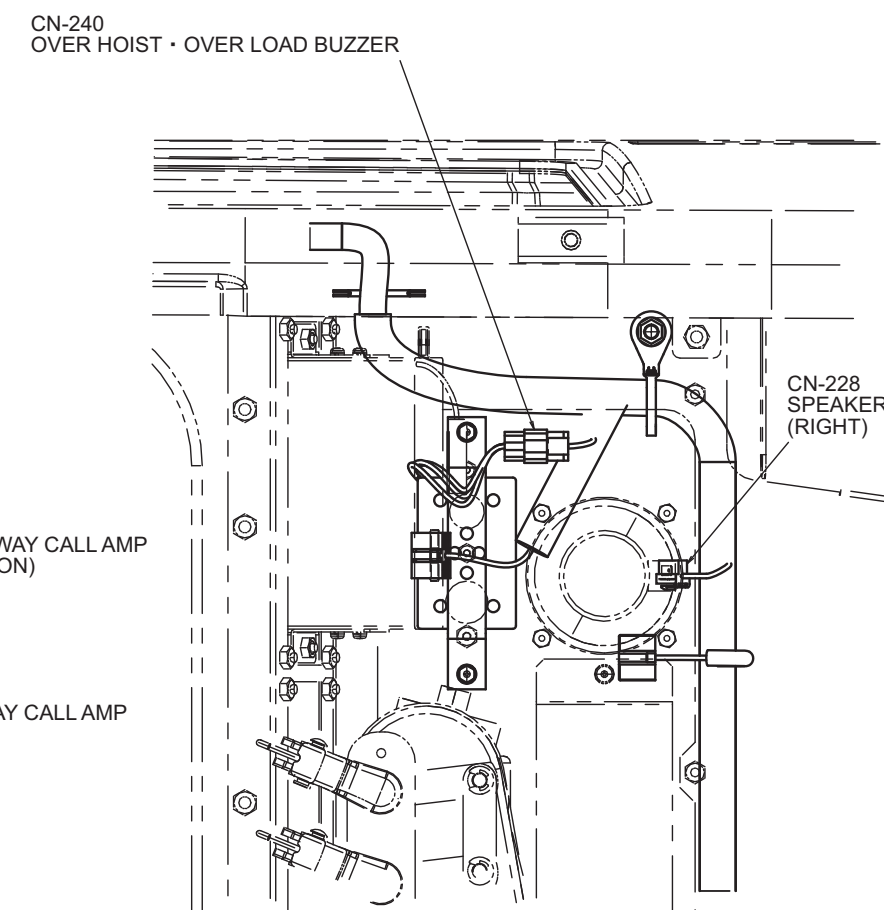
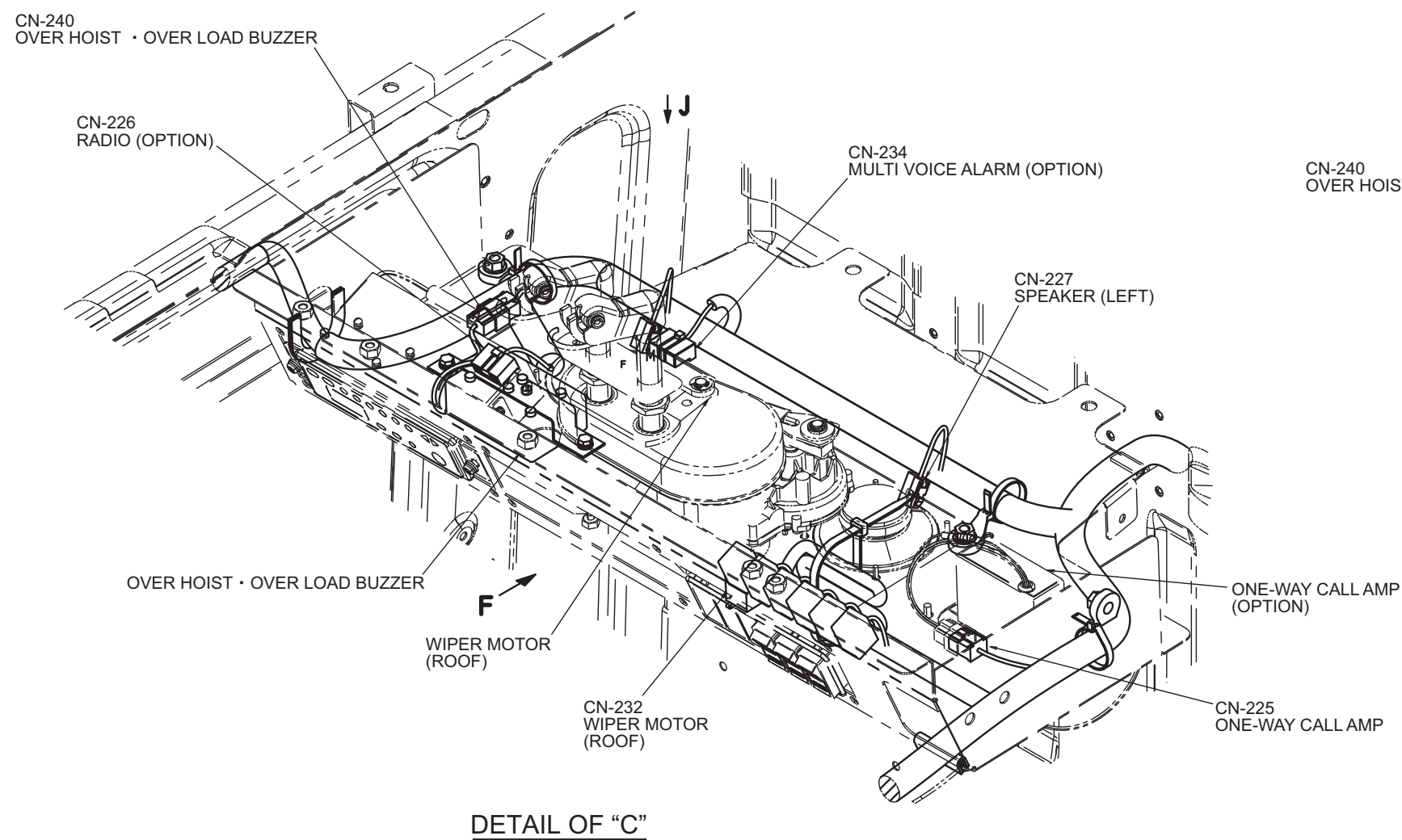

SOL : SOLENOID VALVE
 SW : SWITCH
 PSW : PRESSURE SWITCH
 ATT. : ATTACHMENT
 C/W : COUNTER WEIGHT
 CB/W : CARBODY WEIGHT

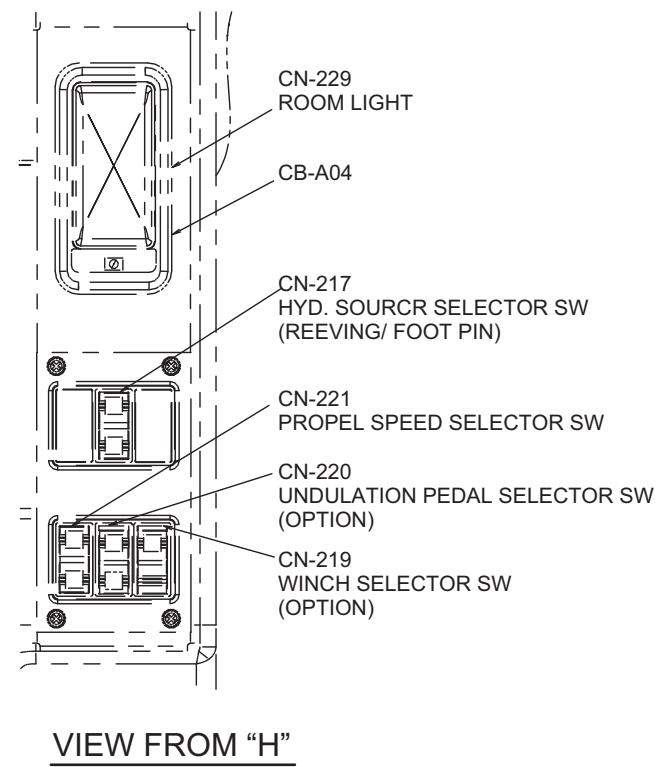
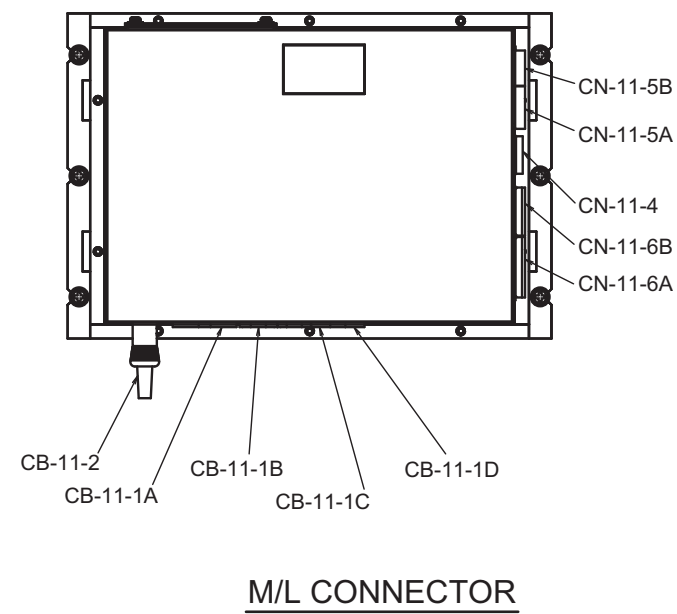
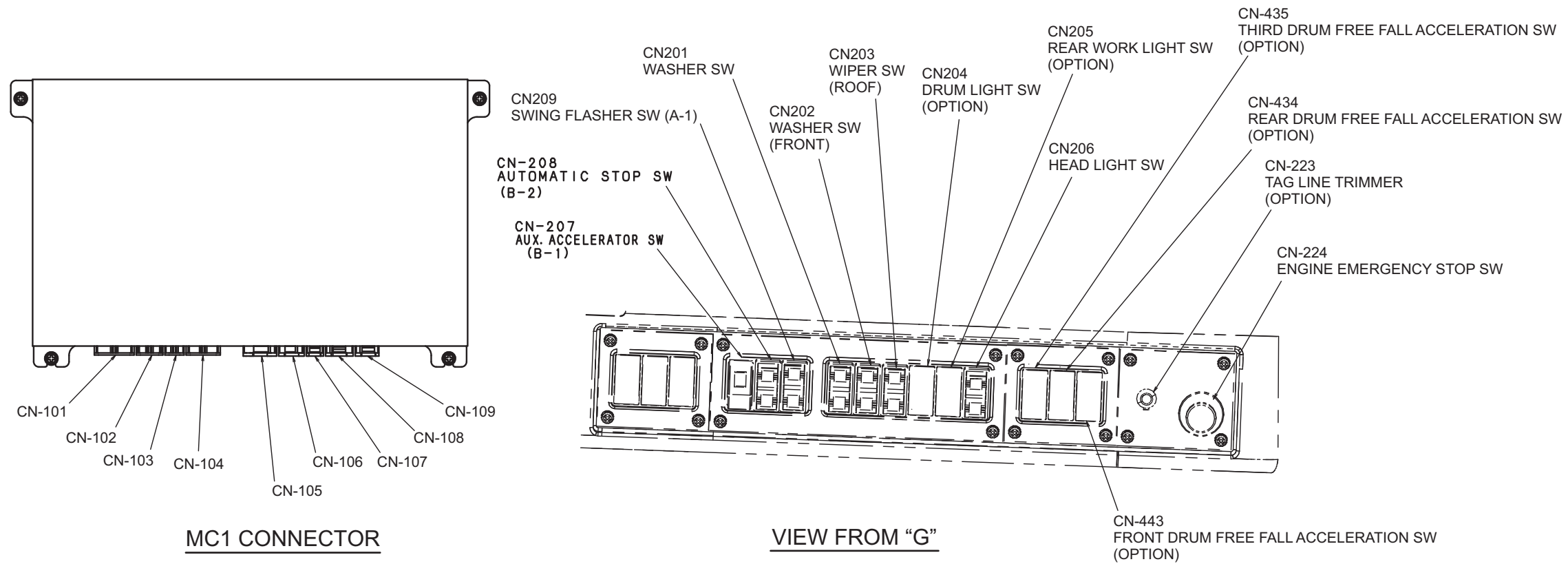

CAB HARNESS

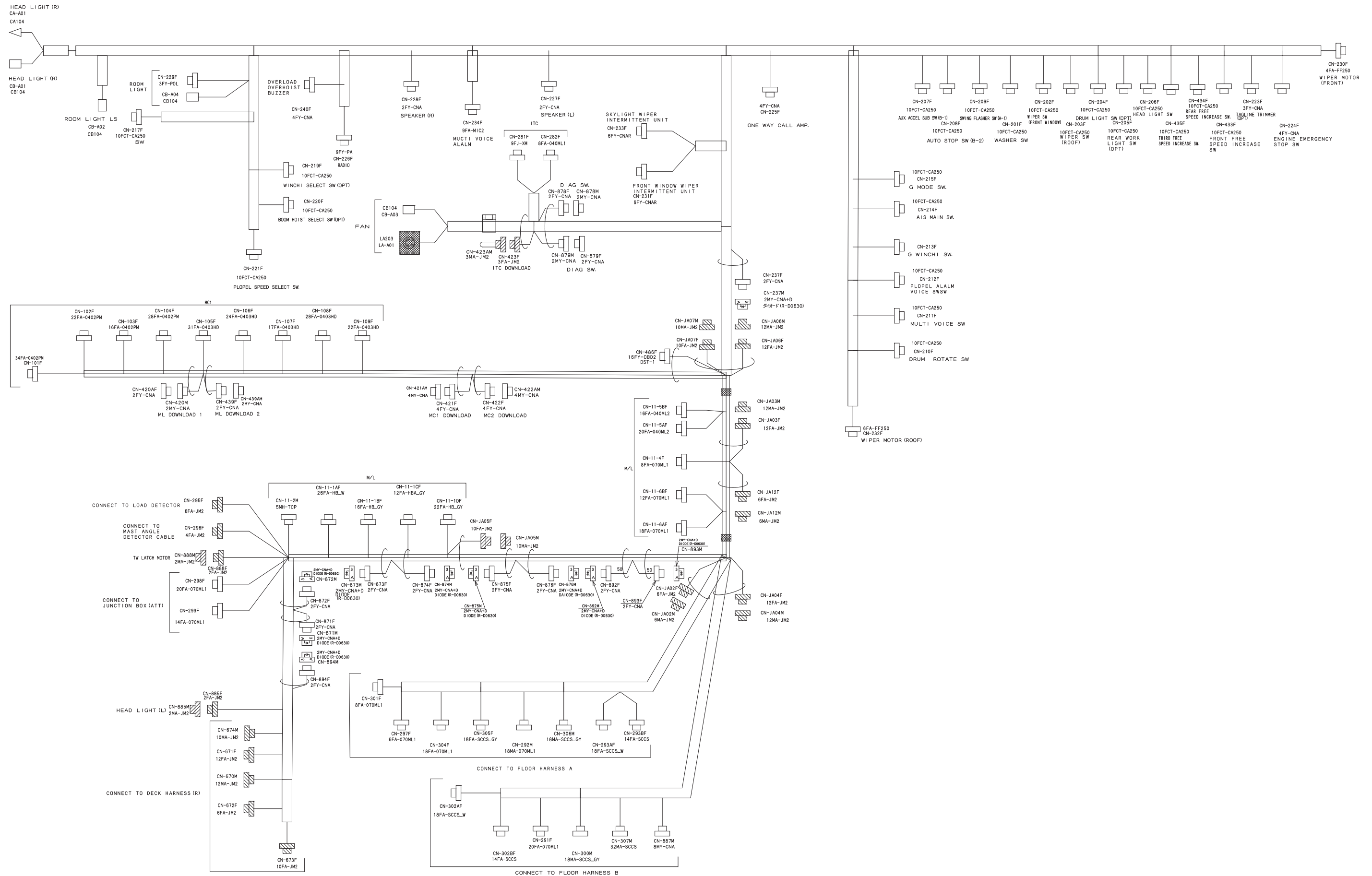

10. ELECTRIC SYSTEM

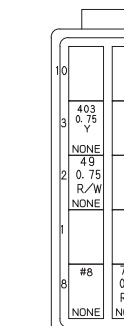
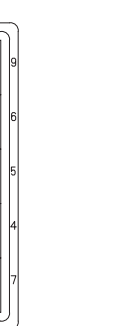
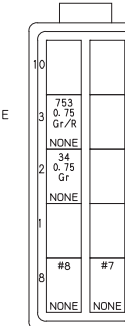
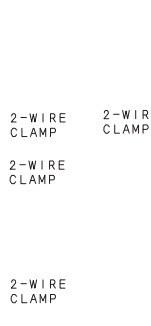
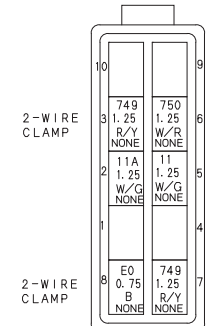
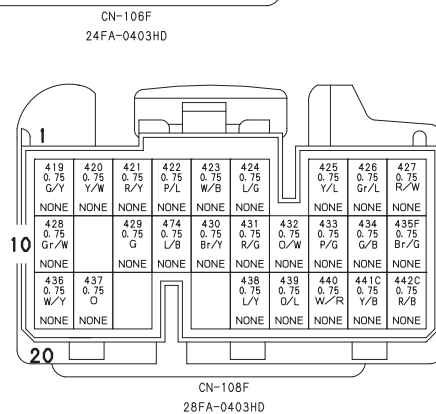
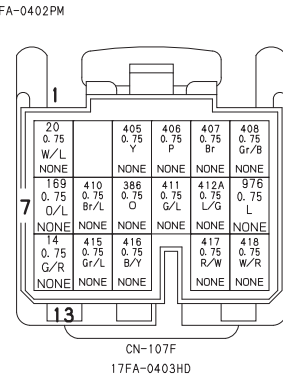
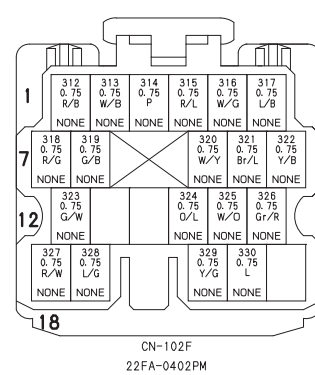
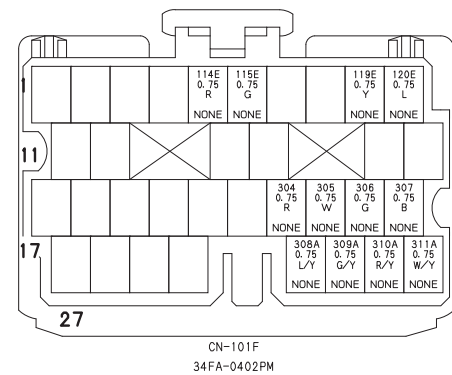
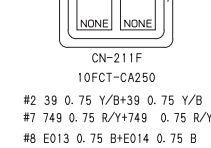
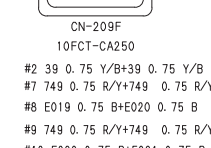
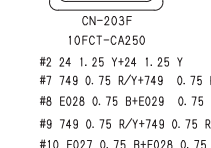
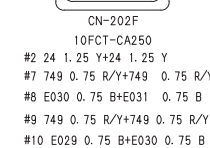
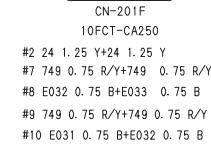
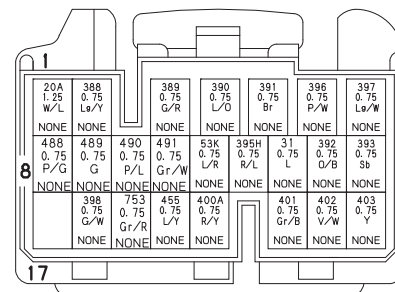
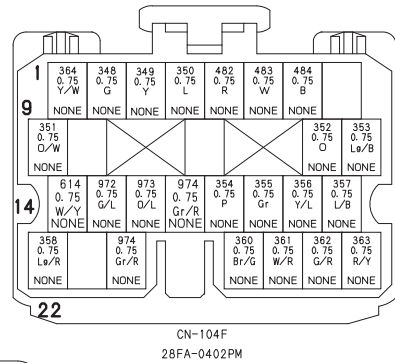
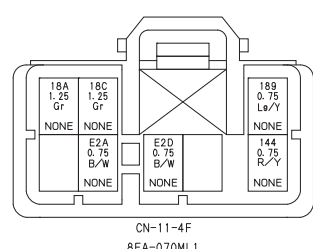
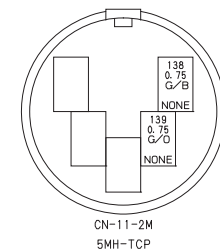
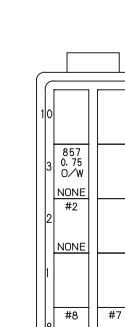
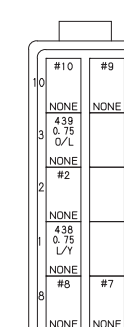
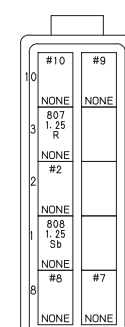
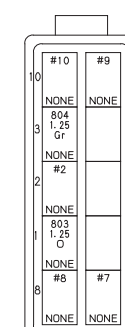
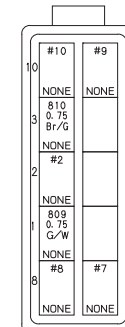
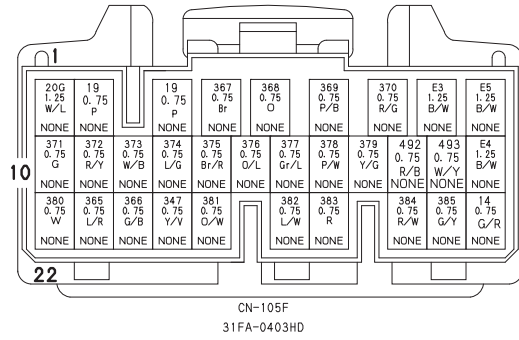
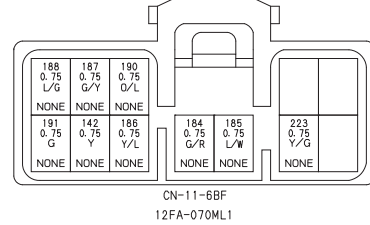
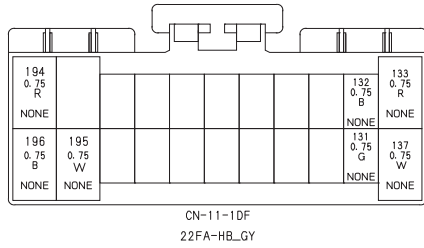
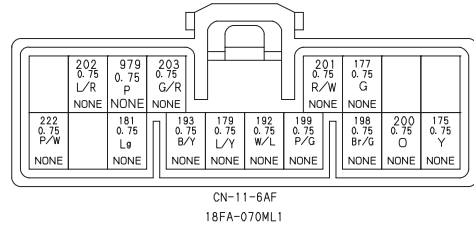
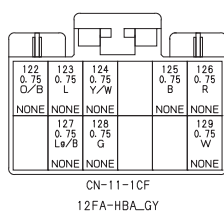
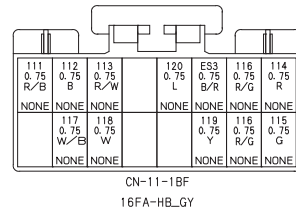
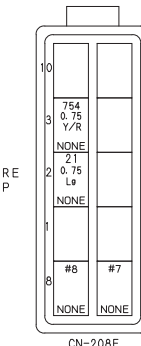
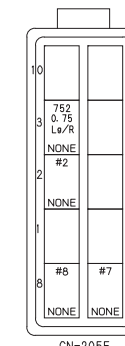
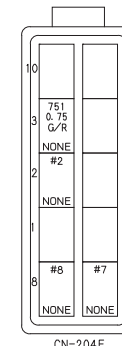
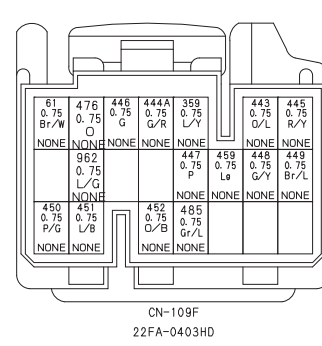
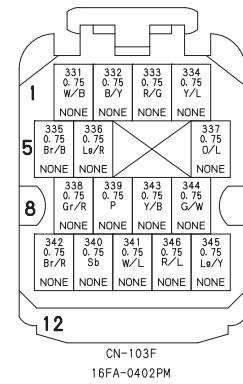
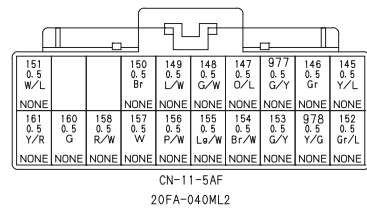
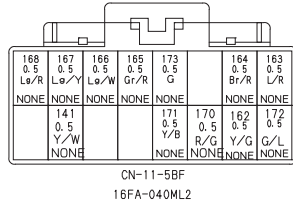
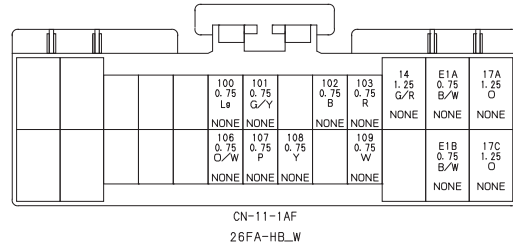

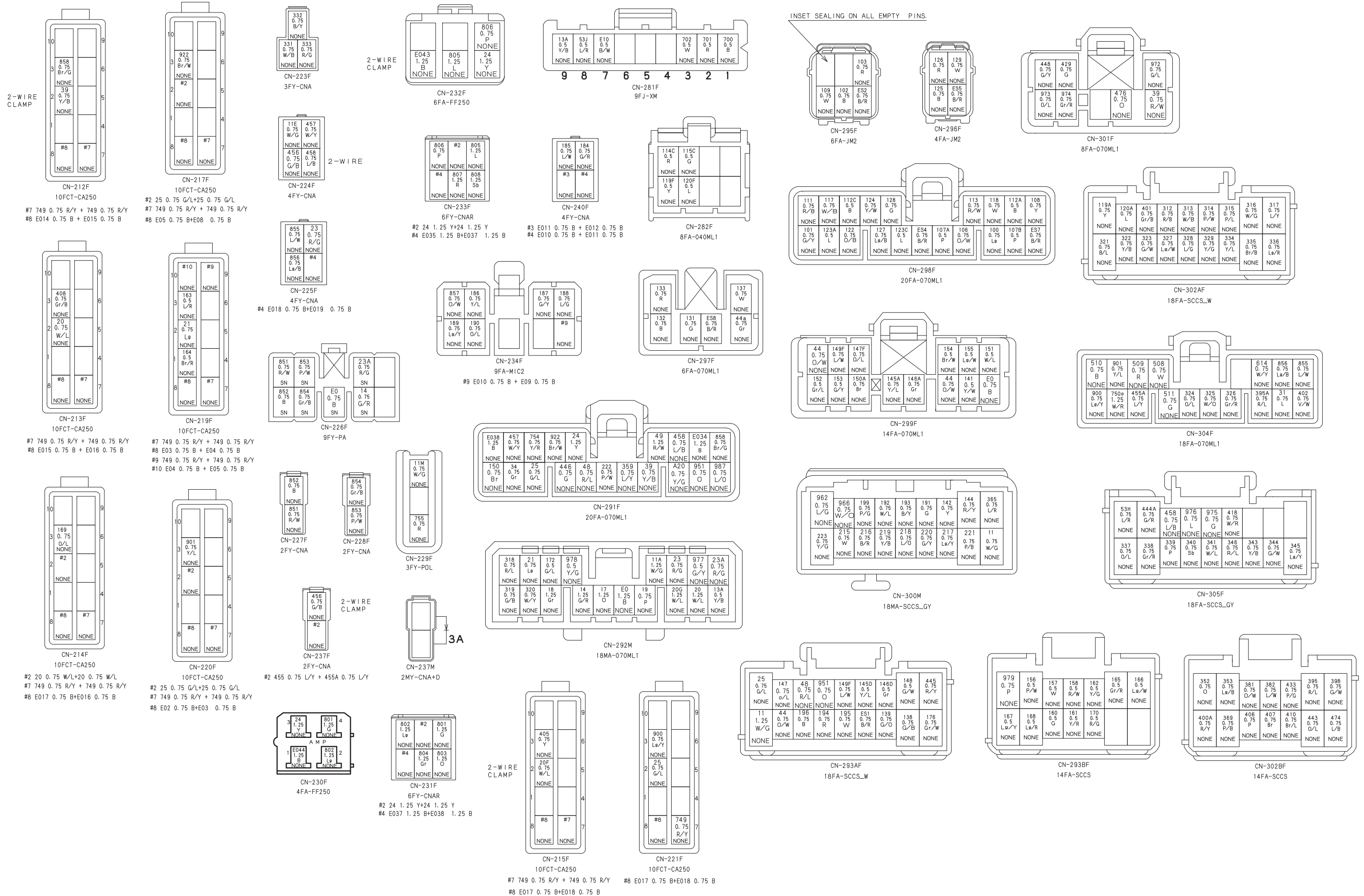

WIRE No. AND WIRE COLER LIST

WIRE NO.	COLER	TYPE	SIZE	F R O M	2-WIRE CLAMP No.	CONNECTION	2-WIRE CLAMP No.	TO	WIRE NO.	COLER	TYPE	SIZE	F R O	2-WIRE CLAMP No.	CONNECTION	2-WIRE CLAMP No.	TO	WIRE NO.	COLER	TYPE	SIZE	F R O	2-WIRE CLAMP No.	CONNECTION	2-WIRE CLAMP No.	TO	WIRE NO.	COLER	TYPE	SIZE	F R O	2-WIRE CLAMP No.	CONNECTION	2-WIRE CLAMP No.	TO
11A	W/G	AVSS	1.25	CN-292M				CN-206F	118	W	AVSS	0.75	CN-11-1BF				CN-298F	219	Y/B	AVSS	0.75	CN-300M				CN-874F	416	B/Y	AVSS	0.75	CN-107F			CN-434F	
11	W/G	AVSS	1.25	CN-293AF			DSA35	CN-206F	122	O/B	AVSS	0.75	CN-11-1CF				CN-298F	220	G/Y	AVSS	0.75	CN-300M				CN-893F	417	R/W	AVSS	0.75	CN-107F			CN-435F	
11E	W/G	AVSS	0.75	JS-A1			DSA35	CN-206F	123	L	AVSS	0.75	JS-A20				CN-11-1CF	221	P/B	AVSS	0.75	CN-300M				CN-876F	418	W/R	AVSS	0.75	CN-305F			CN-107F	
11M	W/G	AVSS	0.75	JS-A1				CN-224F	123A	L	AVSS	0.5	JS-A20				CN-298F	222	P/W	AVSS	0.75	CN-11-6AF				CN-291F	419	G/Y	AVSS	0.75	CN-108F			CN-307M	
11	W/G	AVSS	0.75	JS-A1				CN-229F	123C	L	AVSS	0.5	JS-A20				CN-298F	223	Y/G	AVSS	0.75	CN-11-6BF				CN-300M	420	Y/W	AVSS	0.75	CN-108F			CN-307M	
13A	Y/B	AVSS	0.5	CN-292M				CN-300M	124	Y/W	AVSS	0.75	CN-11-1CF				CN-298F	308A	L/Y	AVSS	0.75	CN-101F				CN-674M	421	R/Y	AVSS	0.75	CN-108F			CN-307M	
14	G/R	AVSS	0.75	CN-226F				CN-JA07F	125	B	AVSS	0.75	CN-11-1CF				CN-296F	309A	G/Y	AVSS	0.75	CN-674M				CN-101F	422	P/L	AVSS	0.75	CN-108F			CN-307M	
14	G/R	AVSS	1.25	CN-11-1AF				CN-JA07F	126	R	AVSS	0.75	CN-11-1CF				CN-296F	310A	R/Y	AVSS	0.75	CN-674M				CN-101F	423	W/B	AVSS	0.75	CN-108F			CN-307M	
14	G/R	AVSS	0.75	CN-JA07F				CN-JA07F	127	Lg/B	AVSS	0.75	CN-11-1CF				CN-298F	311A	W/Y	AVSS	0.75	CN-101F				CN-674M	424	L/G	AVSS	0.75	CN-108F			CN-307M	
14	G/R	AVSS	0.75	CN-JA07F				CN-292M	128	G	AVSS	0.75	CN-11-1CF				CN-298F	312	R/B	AVSS	0.75	CN-302AF				CN-102F	425	Y/L	AVSS	0.75	CN-108F			CN-307M	
14	G/R	AVSS	0.75	CN-JA07F				CN-105F	129	W	AVSS	0.75	CN-11-1CF				CN-296F	313	W/B	AVSS	0.75	CN-302AF				CN-102F	426	Gr/L	AVSS	0.75	CN-108F			CN-307M	
14	G/R	AVSS	0.75	CN-JA07F				CN-107F	131	G	AVSS	0.75	CN-11-1DF				CN-297F	314	P	AVSS	0.75	CN-302AF				CN-102F	427	R/W	AVSS	0.75	CN-108F			CN-307M	
17	O	AVSS	1.25	CN-JA02F				CN-292M	132	B	AVSS	0.75	CN-11-1DF				CN-297F	315	R/L	AVSS	0.75	CN-302AF				CN-102F	428	Gr/W	AVSS	0.75	CN-108F			CN-307M	
17A	O	AVSS	1.25	CN-JA02F				CN-11-1AF	133	R	AVSS	0.75	CN-11-1DF				CN-297F	316	W/G	AVSS	0.75	CN-302AF				CN-102F	429	G	AVSS	0.75	CN-108F			CN-301F	
17C	O	AVSS	1.25	CN-JA02F				CN-11-1AF	137	W	AVSS	0.75	CN-11-1DF				CN-297F	317	L/B	AVSS	0.75	CN-302AF				CN-102F	430	Br/Y	AVSS	0.75	CN-108F			CN-307M	
18	Gr	AVSS	1.25	CN-JA02F				CN-292M	138	G/B	AVSS	0.75	CN-11-2M				CN-293AF	318	R/G	AVSS	0.75	CN-102F				CN-292M	431	R/G	AVSS	0.75	CN-108F			CN-307M	
18A	Gr	AVSS	1.25	CN-JA02F				CN-11-4F	139	G/O	AVSS	0.75	CN-11-2M				CN-293AF	320	W/Y	AVSS	0.75	CN-102F				CN-292M	433	P/G	AVSS	0.75	CN-108F			CN-302BF	
18C	Gr	AVSS	1.25	CN-JA02F				CN-11-4F	141	Y/W	AVSS	0.5	CN-299F				CN-11-5BF	321	Br/L	AVSS	0.75	CN-302AF				CN-102F	434	G/B	AVSS	0.75	CN-108F			CN-673F	
19	P	AVSS	0.75	CN-292M				JS-A11	142	Y	AVSS	0.75	CN-300M				CN-11-6BF	322	Y/B	AVSS	0.75	CN-302AF				CN-102F	435F	Br/G	AVSS	0.75	CN-108F			CN-306M	
19	P	AVSS	0.75	CN-105F				JS-A11	144	R/Y	AVSS	0.75	CN-11-4F				CN-300M	323	G/W	AVSS	0.75	CN-302AF				CN-102F	436	W/Y	AVSS	0.75	CN-108F			CN-307M	
19	P	AVSS	0.75	JS-A12				JS-A11	145	Y/L	AVSS	0.5	CN-11-5AF				CN-JA04F	324	O/L	AVSS	0.75	CN-304F				CN-102F	437	O	AVSS	0.75	CN-108F			CN-307M	
19	P	AVSS	0.75	JS-A12				CN-105F	145	Y/L	AVSS	0.75	CN-299F				CN-JA04F	325	W/O	AVSS	0.75	CN-304F				CN-102F	438	L/Y	AVSS	0.75	CN-209F			CN-108F	
19	P	AVSS	0.75	JS-A12				CN-435F	145	Y/L	AVSS	0.5	CN-293AF				CN-JA04F	326	Gr/R	AVSS	0.75	CN-304F				CN-102F	439	O/L	AVSS	0.75	CN-209F			CN-108F	
19	P	AVSS	0.75	CN-434F	DSA121		DSA120	CN-435F	146	Gr	AVSS	0.5	CN-11-5AF				CN-JA04F	327	R/W	AVSS	0.75	CN-302AF				CN-102F	440	W/R	AVSS	0.75	CN-108F			CN-307M	
19	P	AVSS	0.75	CN-434F	DSA121		DSA121	CN-433F	146	Gr	AVSS	0.75	CN-299F				CN-JA04F	328	L/G	AVSS	0.75	CN-302AF				CN-102F	441C	Y/B	AVSS	0.75	CN-108F			CN-306M	
20	W/L	AVSS	1.25	CN-292M				JS-A13	146	Gr	AVSS	0.5	CN-293AF				CN-JA04F	329	Y/G	AVSS	0.75	CN-302AF				CN-102F	442C	R/B	AVSS	0.75	CN-108F			CN-306M	
20	W/L	AVSS	1.25	CN-105F				JS-A13	146	Gr	AVSS	0.5	CN-293AF				CN-JA04F	330	L	AVSS	0.75	CN-102F				CN-670M	443	O/L	AVSS	0.75	CN-109F			CN-302BF	
20	W/L	AVSS	0.75	CN-107F				JS-A13	147	O/L	AVSS	0.5	CN-11-5AF				CN-JA04F	331	W/B	AVSS	0.75	CN-223F				CN-103F	444A	G/R	AVSS	0.75	CN-109F			CN-305F	
20	W/L	AVSS	1.25	CN-292M				JS-A14	147	O/L	AVSS	0.75	CN-293AF				CN-JA04F	332	B/Y	AVSS	0.75	CN-223F				CN-103F	445	R/Y	AVSS	0.75	CN-109F			CN-293AF	
20	W/L	AVSS	1.25	CN-106F				JS-A14	147	O/L	AVSS	0.75	CN-299F				CN-JA04F	333	R/G	AVSS	0.75	CN-223F				CN-103F	446	G	AVSS	0.75	CN-109F			CN-291F	
20	W/L	AVSS	0.75	CN-215F	DSA49			JS-A14	148	G/W	AVSS	0.5	CN-293AF				CN-JA04F	334	Y/L	AVSS	0.75	CN-302AF				CN-103F	447	P	AVSS	0.75	CN-109F			CN-307M	
20	W/L	AVSS	0.75	CN-215F	DSA49			CN-214F	149	L/W	AVSS	0.5	JS-A15				CN-11-5AF	335	Br/B	AVSS	0.75	CN-302AF				CN-103F	448	G/Y	AVSS	0.75	CN-109F			CN-301F	
20	W/L	AVSS	0.75	CN-213F			DSA207	CN-214F	149	L/W	AVSS	0.75	JS-A15				CN-293AF	336	Lg/R	AVSS	0.75	CN-302AF				CN-103F	449	Br/L	AVSS	0.75	CN-109F			CN-307M	
21	Lg	AVSS	0.75	CN-292M			DSA209	CN-439F	149	L/W	AVSS	0.75	JS-A15				CN-299F	337	O/L	AVSS	0.75	CN-305F				CN-103F	450	P/G	AVSS	0.75	CN-109F			CN-307M	
21	Lg	AVSS	0.75	CN-208F	DSA200		DSA209	CN-439F	150	Br	AVSS	0.5	CN-JA04F				CN-11-5AF	338	Gr/R	AVSS	0.75	CN-305F				CN-103F	451	L/B	AVSS	0.75	CN-109F			CN-307M	
21	Lg	AVSS	0.75	CN-208F	DSA200			CN-219F	150A	Br	AVSS	0.75	CN-JA04F				CN-299F	339	P	AVSS	0.75	CN-305F				CN-103F	452	O/B	AVSS	0.75	CN-109F			CN-307M	
23	R/G	AVSS	0.75	LA-A01	DSA13			CN-292M	150C	Br	AVSS	0.75	CN-JA04F				CN-291F	340	Sb	AVSS	0.75	CN-305F				CN-103F	455	L/Y	AVSS	0.75	CN-106F			CN-237F	
23	R/G	AVSS	0.75	LA-A01	DSA13			CN-225F	151	W/L	AVSS	0.5	CN-11-5AF				CN-299F	341	W/L	AVSS	0.75	CN-305F				CN-103F	455A	L/Y	AVSS	0.75	CN-304F	DSA73		CN-237F	
23A	R/G	AVSS	0.75	CN-226F				CN-292M	152	Gr/L	AVSS	0.5	CN-11-5AF				CN-299F	342	Br/R	AVSS	0.75	CN-103F				CN-671F	456	G/B	AVSS	0.75	CN-237F	DSA15		CN-224F	
24	Y	AVSS	1.25	CN-231F	DSA1			CN-291F	153	G/Y	AVSS	0.5	CN-11-5AF				CN-299F	343	Y/B	AVSS	0.75	CN-305F				CN-103F	456A	G/B	AVSS	0.75	CN-237F	DSA15		CN-674M	
24	Y	AVSS	1.25	CN-231F	DSA1			CN-233F	154	Br/W	AVSS	0.5	CN-11-5AF				CN-299F	344	G/W	AVSS	0.75	CN-305F				CN-103F	457	W/Y	AVSS	0.75	CN-224F			CN-291F	
24	Y	AVSS	1.25	JS-A7				CN-233F	155	Lg/W	AVSS	0.5	CN-299F				CN-11-5AF	345	Lg/Y	AVSS	0.75	CN-305F				CN-103F	458	L/B	AVSS	0.75	CN-224F	DSA210		CN-305F	
24	Y	AVSS	1.25	JS-A7				CN-232F	156	P/W	AVSS	0.5	CN-11-5AF				CN-293BF	346	R/L	AVSS	0.75	CN-305F				CN-103F	458	L/B	AVSS	0.75	CN-224F	DSA210		CN-291F	
24	Y	AVSS	1.25	JS-A7				CN-201F	157	W	AVSS	0.5	CN-293BF				CN-11-5AF	347	Y/L	AVSS	0.75	CN-307M				CN-105F	459	Lg	AVSS	0.75	CN-109F			CN-307M	
24	Y	AVSS	1.25	CN-202F	DSA22			CN-201F	158	R/W	AVSS	0.5	CN-11-5AF				CN-293BF	348	G	AVSS	0.75	CN-104F				CN-671F	474	L/B	AVSS	0.75	CN-108F			CN-302BF	
24	Y	AVSS	1.25	CN-202F	DSA22			CN-203F	160	G	AVSS	0.5	CN-11-5AF				CN-293BF	349	Y	AVSS	0.75	CN-104F				CN-671F	476	O	AVSS	0.75	CN-109F			CN-301F	
24	Y	AVSS	1.25	CN-230F				CN-203F	161																										

10. ELECTRIC SYSTEM

WIRE NO. AND WIRE COLER LIST

WIRE NO.	COLER	TYPE	SIZE	F R O M	2-WIRE CLAMP No.	CONNECTION	2-WIRE CLAMP No.	TO
483	W	AVSS	0.75	CN-104F				CN-670M
484	B	AVSS	0.75	CN-670M				CN-104F
485	Gr/L	AVSS	0.75	CN-109F				CN-306M
614	W/Y	AVSS	0.75	CN-304F				CN-104F
700	B	AVSS	0.5	CN-281F				CN-423F
701	R	AVSS	0.5	CN-281F				CN-423F
702	W	AVSS	0.5	CN-281F				CN-423F
749	R/Y	AVSS	0.75	CN-220F	DSA94			CN-221F
749	R/Y	AVSS	0.75	CN-220F	DSA94	DSA97		CN-219F
749	R/Y	AVSS	0.75	CN-219F	DSA98	DSA97		CN-219F
749	R/Y	AVSS	0.75	CN-219F	DSA98	DSA99		CN-217F
749	R/Y	AVSS	0.75	JS-A16		DSA99		CN-217F
749	R/Y	AVSS	0.75	JS-A16				CN-885F
749	R/Y	AVSS	0.75	JS-A16				CN-206F
749	R/Y	AVSS	1.25	CN-206F	DSA100	DSA110		CN-206F
749	R/Y	AVSS	1.25	CN-206F	DSA100			CN-433F
749	R/Y	AVSS	0.75	CN-434F	DSA93	DSA94		CN-433F
749	R/Y	AVSS	0.75	CN-434F	DSA93	DSA92		CN-435F
749	R/Y	AVSS	0.75	CN-205F	DSA91	DSA92		CN-435F
749	R/Y	AVSS	0.75	CN-205F	DSA91	DSA90		CN-204F
749	R/Y	AVSS	0.75	CN-203F	DSA89	DSA90		CN-204F
749	R/Y	AVSS	0.75	CN-203F	DSA89	DSA88		CN-203F
749	R/Y	AVSS	0.75	CN-202F	DSA87	DSA88		CN-203F
749	R/Y	AVSS	0.75	CN-202F	DSA87	DSA86		CN-202F
749	R/Y	AVSS	0.75	CN-201F	DSA85	DSA86		CN-202F
749	R/Y	AVSS	0.75	CN-201F	DSA85	DSA85		CN-201F
749	R/Y	AVSS	0.75	CN-209F	DSA83	DSA84		CN-201F
749	R/Y	AVSS	0.75	CN-209F	DSA83	DSA82		CN-209F
749	R/Y	AVSS	0.75	CN-208F	DSA81	DSA82		CN-209F
749	R/Y	AVSS	0.75	CN-208F	DSA81	DSA80		CN-207F
749	R/Y	AVSS	0.75	CN-215F	DSA102	DSA80		CN-207F
749	R/Y	AVSS	0.75	CN-215F	DSA102	DSA103		CN-214F
749	R/Y	AVSS	0.75	CN-213F	DSA105	DSA103		CN-214F
749	R/Y	AVSS	0.75	CN-213F	DSA105	DSA107		CN-212F
749	R/Y	AVSS	0.75	CN-211F	DSA109	DSA107		CN-212F
749	R/Y	AVSS	0.75	CN-211F	DSA109			CN-210F
750	W/R	AVSS	1.25	CN-206F	DSA101			CB-A01
750	W/R	AVSS	1.25	CN-206F	DSA101			CN-304F
751	G/R	AVSS	0.75	CN-204F				CN-670M
752	Lg/R	AVSS	0.75	CN-670M				CN-205F
753	Gr/R	AVSS	0.75	CN-674M		DSA208		CN-207F
753	Gr/R	AVSS	0.75	CN-106F		DSA208		CN-207F
754	Y/R	AVSS	0.75	CN-208F				CN-291F
755	R	AVSS	0.75	CN-229F				CB-A02
801	G	AVSS	1.25	CN-230F				CN-231F
802	Lg	AVSS	1.25	CN-230F				CN-231F
803	O	AVSS	1.25	CN-202F				CN-231F
804	Gr	AVSS	1.25	CN-231F				CN-202F
805	L	AVSS	1.25	CN-233F				CN-232F
806	P	AVSS	0.75	CN-233F				CN-232F
807	R	AVSS	1.25	CN-233F				CN-203F
808	Sb	AVSS	1.25	CN-203F				CN-233F
809	G/W	AVSS	0.75	CN-201F				CN-670M
810	Br/G	AVSS	0.75	CN-201F				CN-670M
857	O/W	AVSS	0.75	CN-211F				CN-234F
858	Br/G	AVSS	0.75	CN-291F				CN-212F
900	Lg/Y	AVSS	0.75	CN-304F				CN-221F
901	Y/L	AVSS	0.75	CN-220F				CN-304F
922	Br/W	AVSS	0.75	CN-291F				CN-217F
951	O	AVSS	0.75	CN-291F				CN-293AF
962	L/G	AVSS	0.75	CN-300M				CN-109F
966	W/O	AVSS	0.75	CN-300M				CN-894F
972	G/L	AVSS	0.75	CN-301F				CN-104F
973	O/L	AVSS	0.75	CN-301F				CN-104F
974	Gr/R	AVSS	0.75	CN-104F				JS-A21
974	Gr/R	AVSS	0.75	CN-104F				JS-A21
974	Gr/R	AVSS	0.75	CN-301F				JS-A21
975	G	AVSS	0.75	CN-888F				CN-305F
976	L	AVSS	0.75	CN-888F				JS-A22
976	L	AVSS	0.75	CN-305F				JS-A22
976	L	AVSS	0.75	CN-107F				JS-A22
977	G/Y	AVSS	0.5	CN-11-5AF				CN-292M
978	Y/G	AVSS	0.5	CN-11-5AF				CN-292M
979	P	AVSS	0.75	CN-11-6AF				CN-293BF
987	L/O	AVSS	0.75	CN-291F				CN-878F
A20	Y/G	AVSS	0.75	CN-486F				CN-291F
ES3	B/R	AVSS	0.75	CN-JA05F				CN-11-1BF
ES1	B/R	AVSS	0.75	CN-JA05F				CN-293AF
ES2	B/R	AVSS	0.75	CN-JA05F				CN-295F
ESJP	B/R	AVSS	0.75	CN-JA05F				CN-JA05F
ES4	B/R	AVSS	0.75	CN-298F				CN-JA05F
ES5	B/R	AVSS	0.75	CN-296F				CN-JA05F
ES7	B/R	AVSS	0.75	CN-298F				CN-JA05F
ES8	B/R	AVSS	0.75	CN-297F				CN-JA05F

WIRE NO.	COLER	TYPE	SIZE	F R O M	2-WIRE CLAMP No.	CONNECTION	2-WIRE CLAMP No.	TO
114	R	AVSS	0.75	CN-JA03F				CN-11-1BF
115	G	AVSS	0.75	CN-JA03F				CN-11-1BF
114C	R	AVSS	0.5	CN-JA03F				CN-282F
115C	G	AVSS	0.5	CN-JA03F				CN-282F
114E	R	AVSS	0.75	CN-JA03F				CN-101F
115E	G	AVSS	0.75	CN-JA03F				CN-101F
114H	R	AVSS	0.75	CN-JA03F				CN-673F
115H	G	AVSS	0.75	CN-JA03F				CN-673F
119	Y	AVSS	0.75	CN-JA06F				CN-11-1BF
120	L	AVSS	0.75	CN-JA06F				CN-11-1BF
119A	Y	AVSS	0.75	CN-JA06F				CN-302AF
120A	L	AVSS	0.75	CN-JA06F				CN-302AF
119B	Y	AVSS	0.75	CN-JA06F				CN-486F
120B	L	AVSS	0.75	CN-JA06F				CN-486F
119E	Y	AVSS	0.75	CN-JA06F				CN-101F
120E	L	AVSS	0.75	CN-JA06F				CN-101F
119F	Y	AVSS	0.5	CN-JA06F				CN-282F
120F	L	AVSS	0.5	CN-JA06F				CN-282F
371	G	AVSS	0.75	CN-105F				CN-306M
380	W	AVSS	0.75	CN-105F				CN-306M
372	R/Y	AVSS	0.75	CN-105F				CN-673F
373	W/B	AVSS	0.75	CN-105F				CN-673F
374	L/G	AVSS	0.75	CN-105F				CN-673F
375	Br/R	AVSS	0.75	CN-105F				CN-673F
376	O/L	AVSS	0.75	CN-105F				CN-673F
377	Gr/L	AVSS	0.75	CN-105F				CN-673F
378	P/W	AVSS	0.75	CN-105F				CN-307M
379	Y/G	AVSS	0.75	CN-105F				CN-307M
388	Lg/Y	AVSS	0.75	CN-106F				CN-307M
389	G/R	AVSS	0.75	CN-106F				CN-307M
390	L/O	AVSS	0.75	CN-106F				CN-307M
391	Br	AVSS	0.75	CN-106F				CN-307M
392	O/B	AVSS	0.75	CN-106F				CN-306M
393	Sb	AVSS	0.75	CN-106F				CN-306M
396	P/W	AVSS	0.75	CN-106F				CN-306M
397	Lg/W	AVSS	0.75	CN-106F				CN-306M
488	P/G	AVSS	0.75	CN-887M				CN-106F
489	G	AVSS	0.75	CN-887M				CN-106F
490	P/L	AVSS	0.75	CN-887M				CN-106F
491	Gr/W	AVSS	0.75	CN-887M				CN-106F
492	R/B	AVSS	0.75	CN-887M				CN-105F
493	W/Y	AVSS	0.75	CN-887M				CN-105F

WIRE NO.	COLER	TYPE	SIZE	F R O M	2-WIRE CLAMP No.	CONNECTION	2-WIRE CLAMP No.	TO
851	R/W	AVSS	0.75	CN-226F				CN-227F
852	B	AVSS	0.75	CN-226F				CN-227F
853	P/W	AVSS	0.75	CN-226F				CN-228F
854	Gr/B	AVSS	0.75	CN-226F				CN-228F
855	L/W	AVSS	0.75	CN-304F				CN-225F
856	Lg/B	AVSS	0.75	CN-225F				CN-304F
304	R	MVVS	0.75	CN-101F				CN-421F
305	W	MVVS	0.75	CN-101F				CN-421F
306	G	MVVS	0.75	CN-101F				CN-421F
307	B	MVVS	0.75	CN-101F				CN-421F
508	W	MVVS	0.75	CN-304F				CN-422F
509	R	MVVS	0.75	CN-304F				CN-422F
510	B	MVVS	0.75	CN-304F				CN-422F
511	G	MVVS	0.75	CN-304F				CN-422F
E0	B	AVSS	1.25	CN-291F				JS-A8
E0	B	AVSS	0.75	CN-226F				JS-A8
E0	B	AVSS	1.25	CN-439F	DSA130			JS-A8
E0	B	AVSS	1.25	CN-439F	DSA130			JS-A300
E0	B	AVSS	0.75	CN-486F				JS-A300
E0	B	AVSS	0.75	CN-879M	DSA131			JS-A300
E0	B	AVSS	0.75	CN-879M	DSA131	DSA132		CB-A03
E0	B	AVSS	0.75	CN-231F	DSA133	DSA132		CB-A03
E0	B	AVSS	0.75	CN-231F	DSA133	DSA134		CN-233F
E0	B	AVSS	0.75	CN-234F	DSA172	DSA134		CN-233F
E0	B	AVSS	0.75	CN-234F	DSA172	DSA138		CN-240F
E0	B	AVSS	0.75	CN-240F	DSA139	DSA138		CN-240F
E0	B	AVSS	0.75	CN-240F	DSA139	DSA140		CN-221F
E0	B	AVSS	0.75	CN-220F	DSA141	DSA140		CN-221F
E0	B	AVSS	0.75	CN-220F	DSA141	DSA142		CN-219F
E0	B	AVSS	0.75	CN-219F	DSA143	DSA142		CN-219F
E0	B	AVSS	0.75	CN-219F	DSA143	DSA144		CN-217F
E0	B	AVSS	0.75	CB-A04	DSA168	DSA144		CN-217F
E0	B	AVSS	0.75	CB-A04	DSA168	DSA52		CA-A01
E0	B	AVSS	0.75	CN-433F	DSA145	DSA52		CA-A01
E0	B	AVSS	0.75	CN-433F	DSA145	DSA146		CN-434F
E0	B	AVSS	0.75	CN-435F	DSA147	DSA146		CN-434F
E0	B	AVSS	0.75	CN-435F	DSA147	DSA167		CN-206F
E0	B	AVSS	0.75	CN-205F	DSA148	DSA167		CN-206F
E0	B	AVSS	0.75	CN-205F	DSA148	DSA149		CN-204F
E0	B	AVSS	0.75	CN-203F	DSA154	DSA149		CN-204F
E0	B	AVSS	0.75	CN-203F	DSA154	DSA152		CN-203F
E0	B	AVSS	0.75	CN-202F				

8. ELECTRICAL PART OF ENGINE

SOL : SOLENOID VALVE
 SW : SWITCH
 PSW : PRESSURE SWITCH
 ATT : ATTACHMENT
 C/W : COUNTER WEIGHT
 CB/W : CARBODY WEIGHT

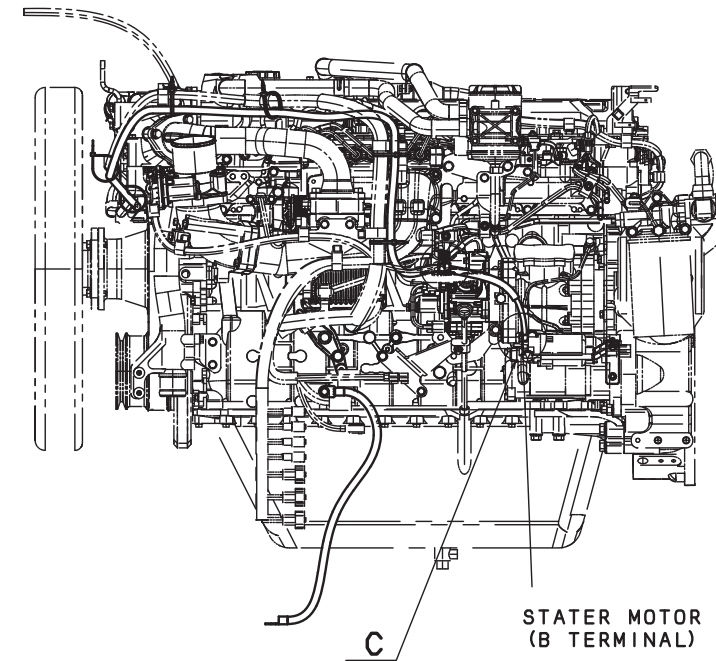
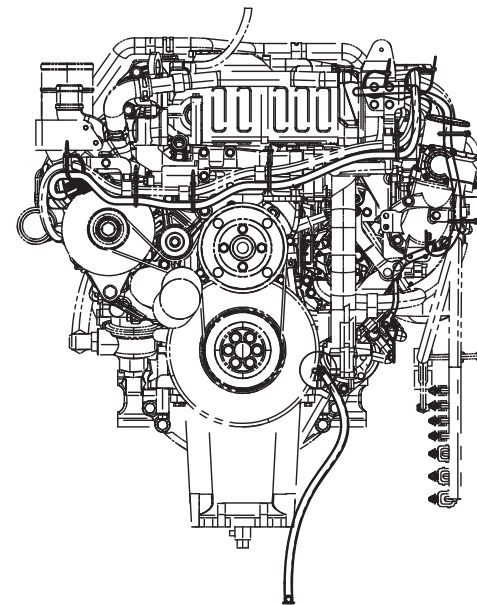
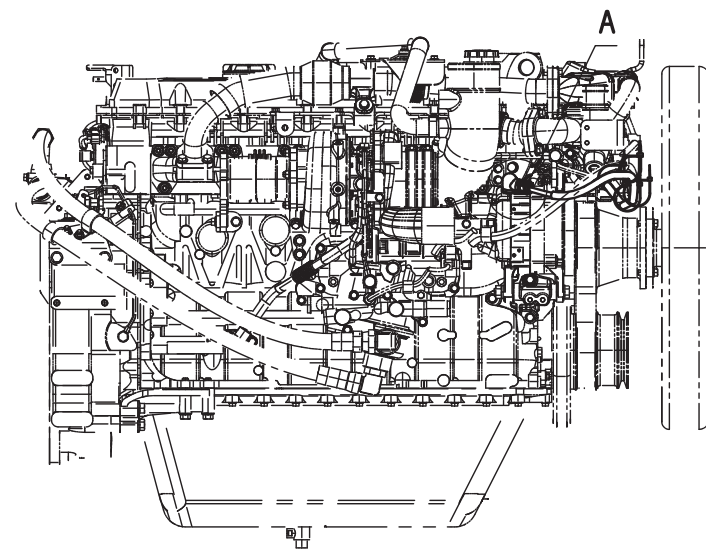

ALTERNATOR
 B TERMINAL
 (DO NOT CONNECT TO
 OTHER THEAN B TERMINAL)

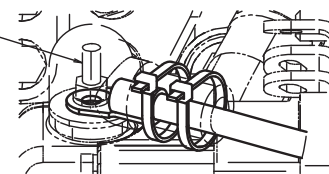

DETAIL A

STATER MOTOR
 (B TERMINAL)

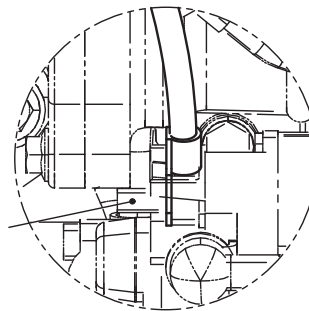

DETAIL C

10. ELECTRIC SYSTEM

STARTER MOTOR HARNESS TO ENGINE GROUND HARNESS

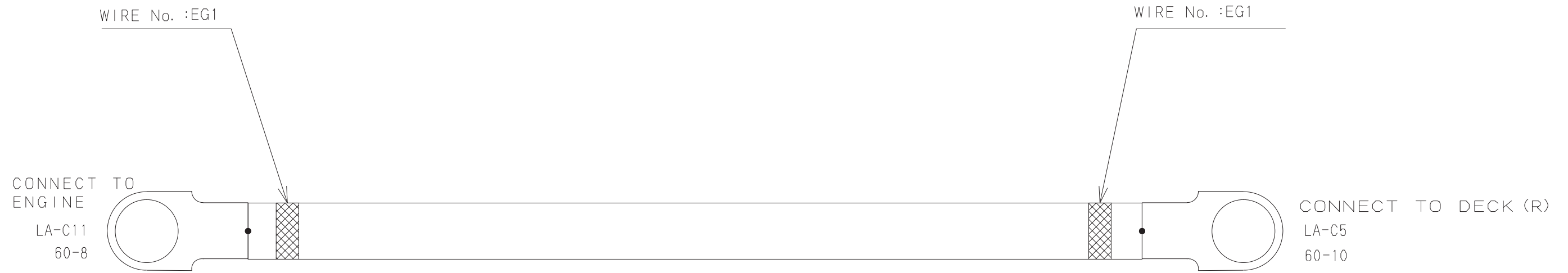

WIRE No. AND WIRE COLER LIST

WIRE No.	COLER	TYPE	SIZE	F R O M	DISTINGUISH SYMBOL	2-WIRE CLAMP No.	CONNECTION	2-WIRE CLAMP No.	DISTINGUISH SYMBOL	TO
EG1	B	AV	60	LA-C11			—————			LA-C5

STARTER MOTOR HARNESS TARMINAL B ALTERNATOR HARNESS TARMINAL B



WIRE No. AND WIRE COLER LIST

WIRE No.	COLER	TYPE	SIZE	F R O M	DISTINGUISH SYMBOL	2-WIRE CLAMP No.	CONNECTION	2-WIRE CLAMP No.	DISTINGUISH SYMBOL	TO
2M	W	AV	20	LA-C3			—————			LA-C10

10. ELECTRIC SYSTEM

9. ELECTRICAL PART OF MONITOR

SOL : SOLENOID VALVE
SW : SWITCH
PSW : PRESSURE SWITCH
ATT. : ATTACHMENT
C/W : COUNTER WEIGHT
CB/W : CARBODY WEIGHT

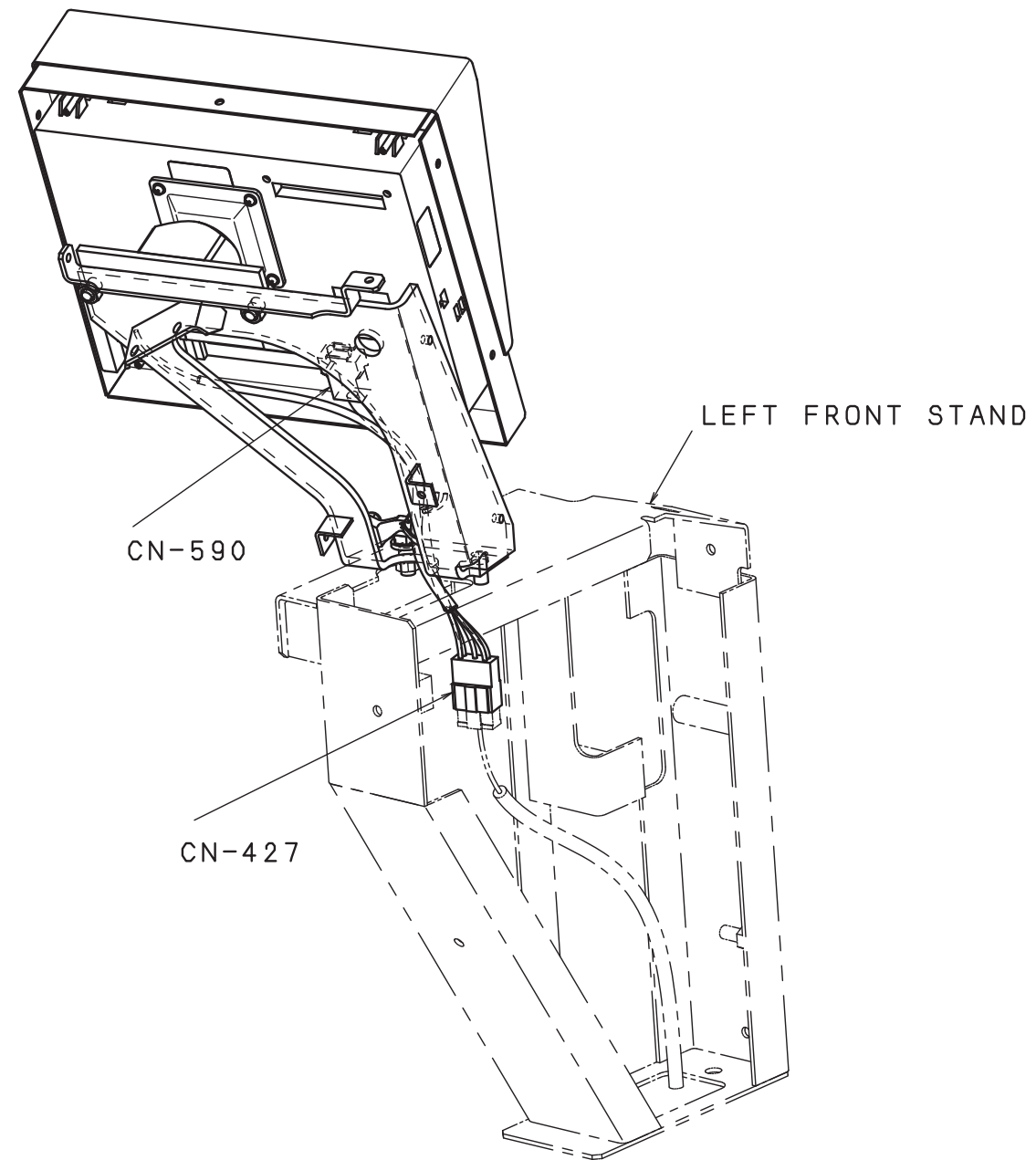

MONITOR HARNESS

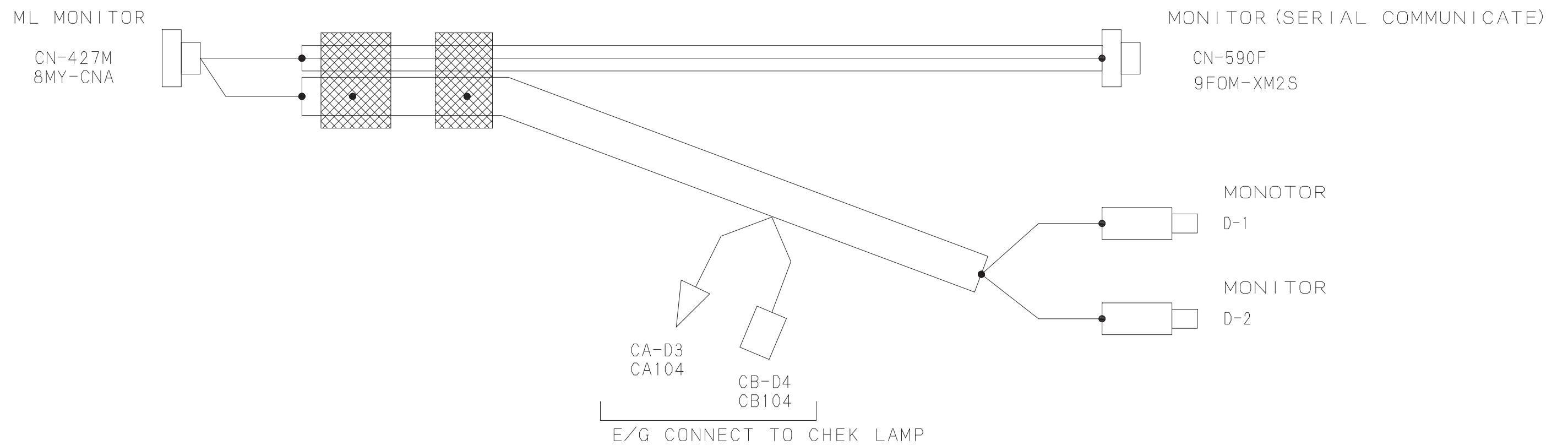

10. ELECTRIC SYSTEM

986 0.75 Y	196 0.75 B 3C4	195 0.75 W 3C4	194 0.75 R 3C4
NONE	NONE	NONE	NONE
458 0.75 L/B	ES2 0.75 B/R 3C4	E11 0.75 B/W	27 0.75 P/W
NONE	NONE	NONE	NONE

CN-427M
8MY-CNA

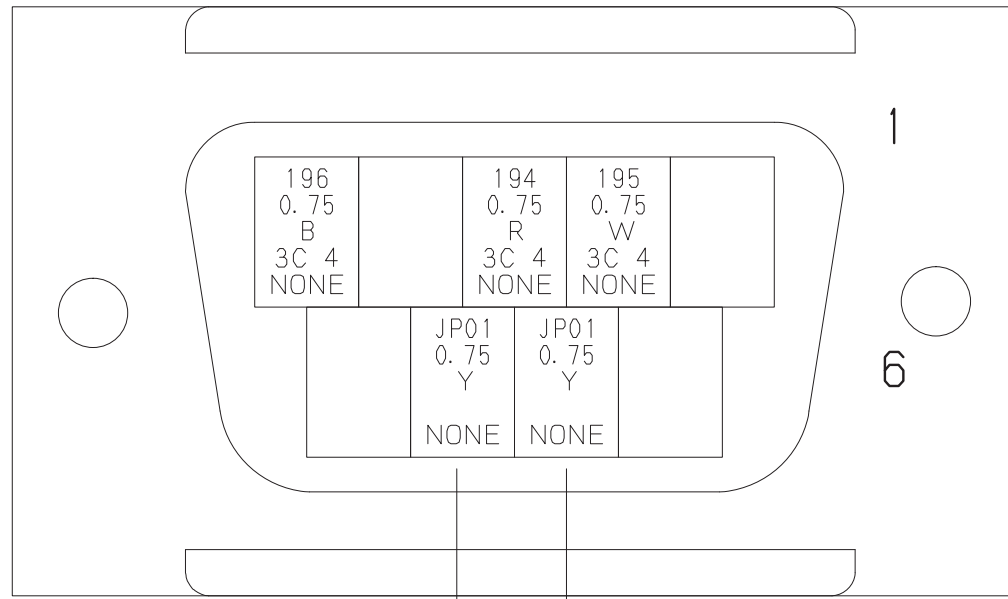

JUMPER
(AVSS 0.75sq)

CN-590F
9FOM-XM2S

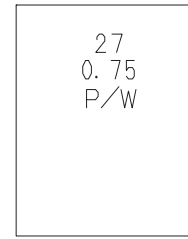

D-1

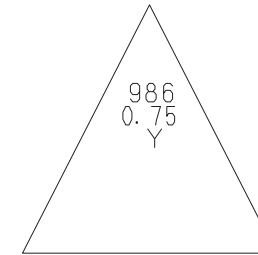

CA-D3
CA104

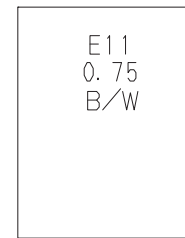

D-2

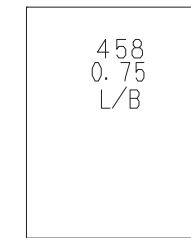

CB-D4
CB104

WIRE No. AND WIRE COLER LIST

WIRE No.	COLER	TYPE	SIZE	FROM	PIN No.	DISTINGUISH SYMBOL	2-WIRE CLAMP No.	CONNECTION	2-WIRE CLAMP No.	DISTINGUISH SYMBOL	PIN No.	TO
27	P/W	AVSS	0.75	CN-427M	5			=====			1	D-1
JP01	Y	AVSS	0.75	CN-590F	7			=====			8	CN-590F
194	R	MVVS	0.75	CN-427M	1	3C4		=====		3C4	3	CN-590F
195	W	MVVS	0.75	CN-427M	2	3C4		=====		3C4	2	CN-590F
196	B	MVVS	0.75	CN-427M	3	3C4		=====		3C4	5	CN-590F
ES2	B/R	AVSS	0.75	CN-427M	7	3C4		=====		3C4		(CN-590F)
E11	B/W	AVSS	0.75	CN-427M	6			=====			1	D-2
458	L/B	AVSS	0.75	CN-427M	8			=====				CB-D4
986	Y/G	AVSS	0.75	CN-427M	4			=====				CA-D3

10. ELECTRICAL PART OF COUNTER WEIGHT SELF REMOVAL (OPTION)

SOL : SOLENOID VALVE
 SW : SWITCH
 PSW : PRESSURE SWITCH
 ATT : ATTACHMENT
 C/W : COUNTER WEIGHT
 CB/W : CARBODY WEIGHT

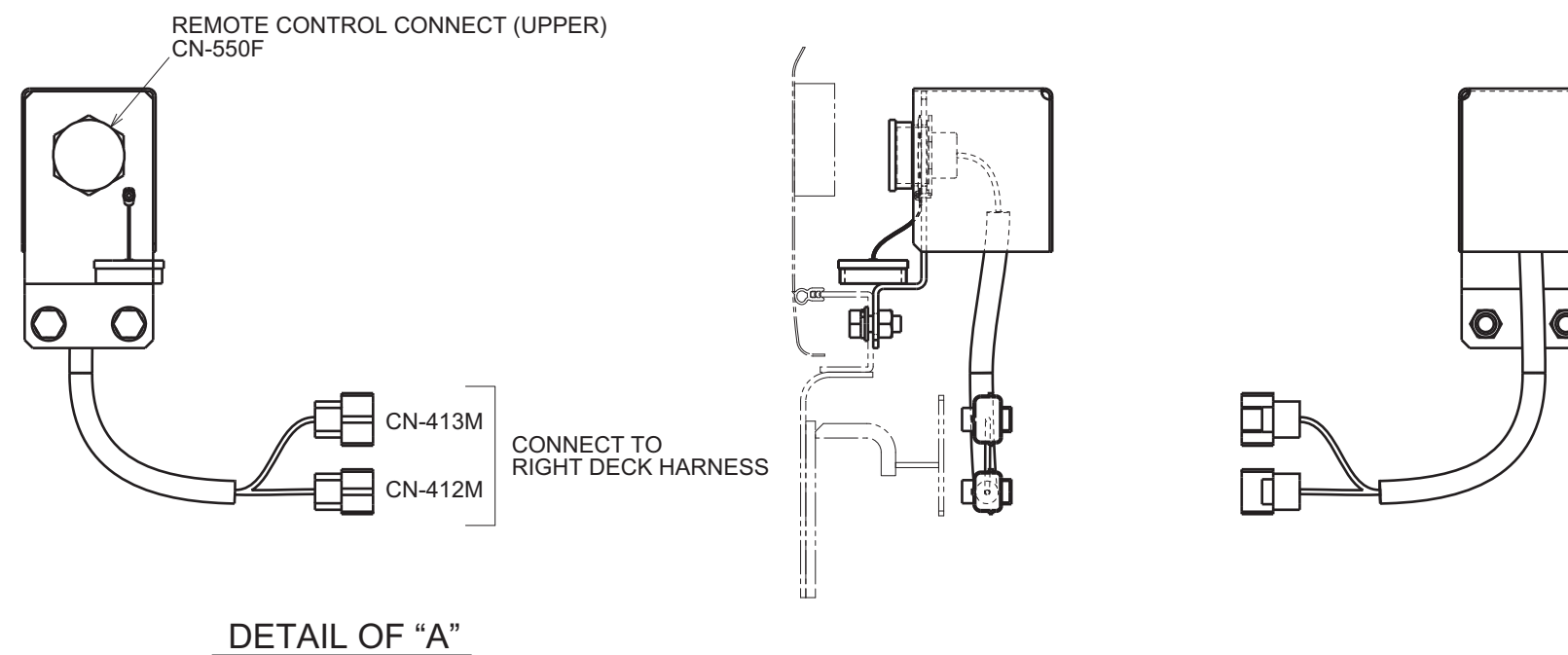
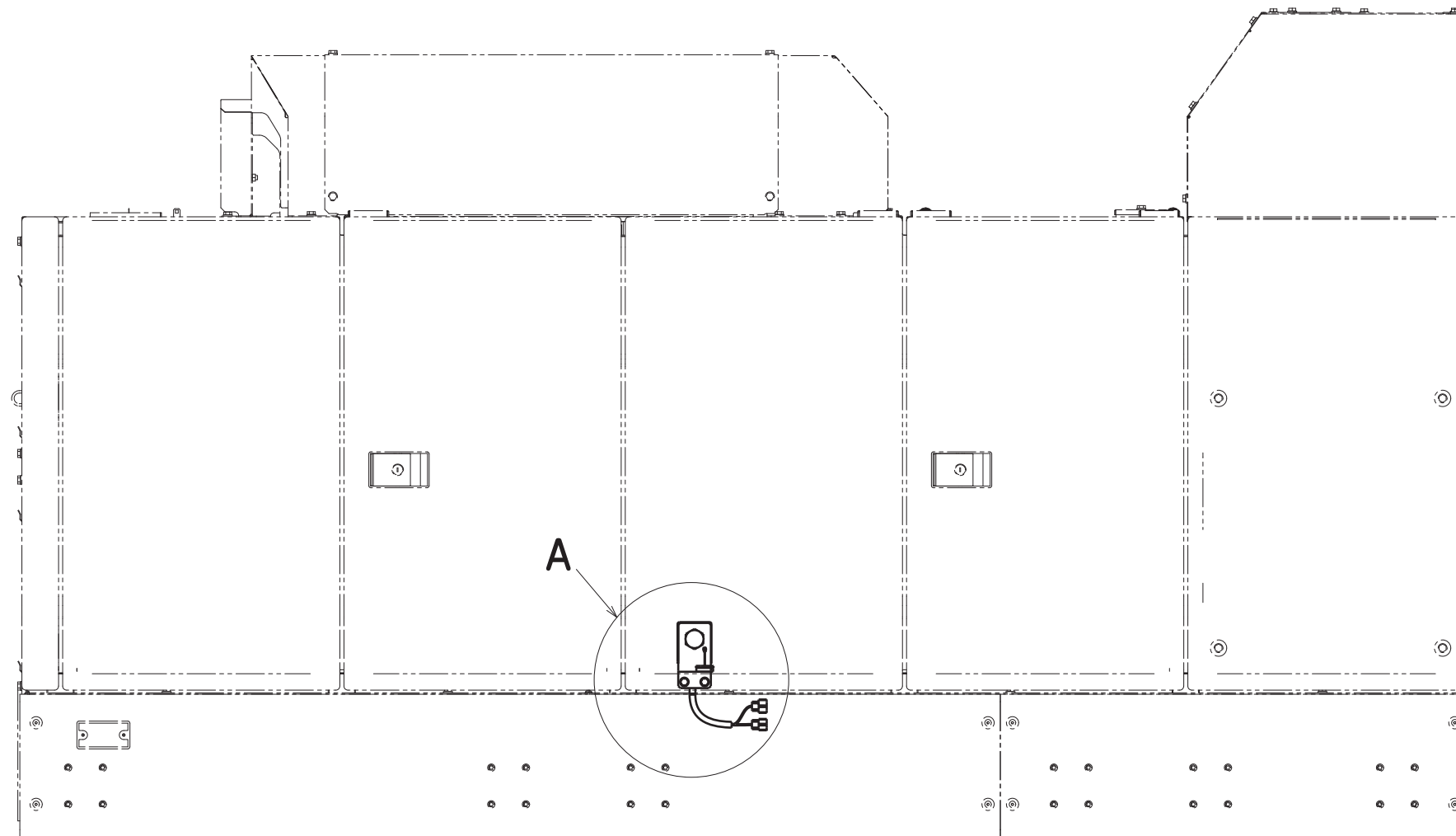

10. ELECTRIC SYSTEM

COUNTER WEIGHT SELF REMOVAL HARNESS



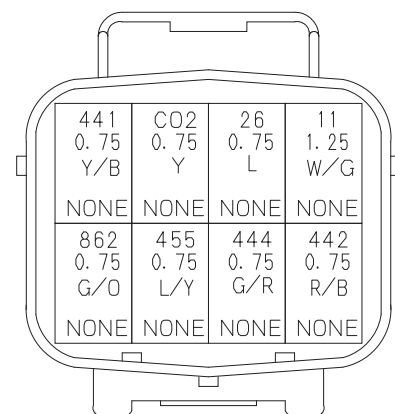

CN-412M
8MA-JM2

INSET SEALING ON ALL EMPTY PINS.

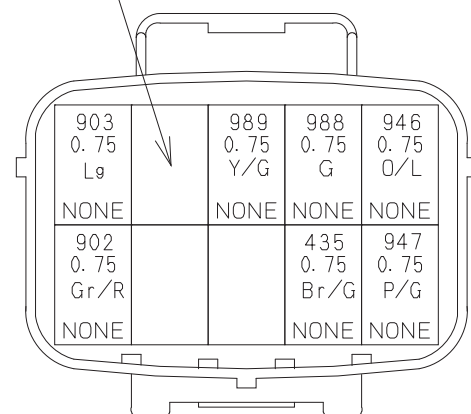

CN-413M
10MA-JM2

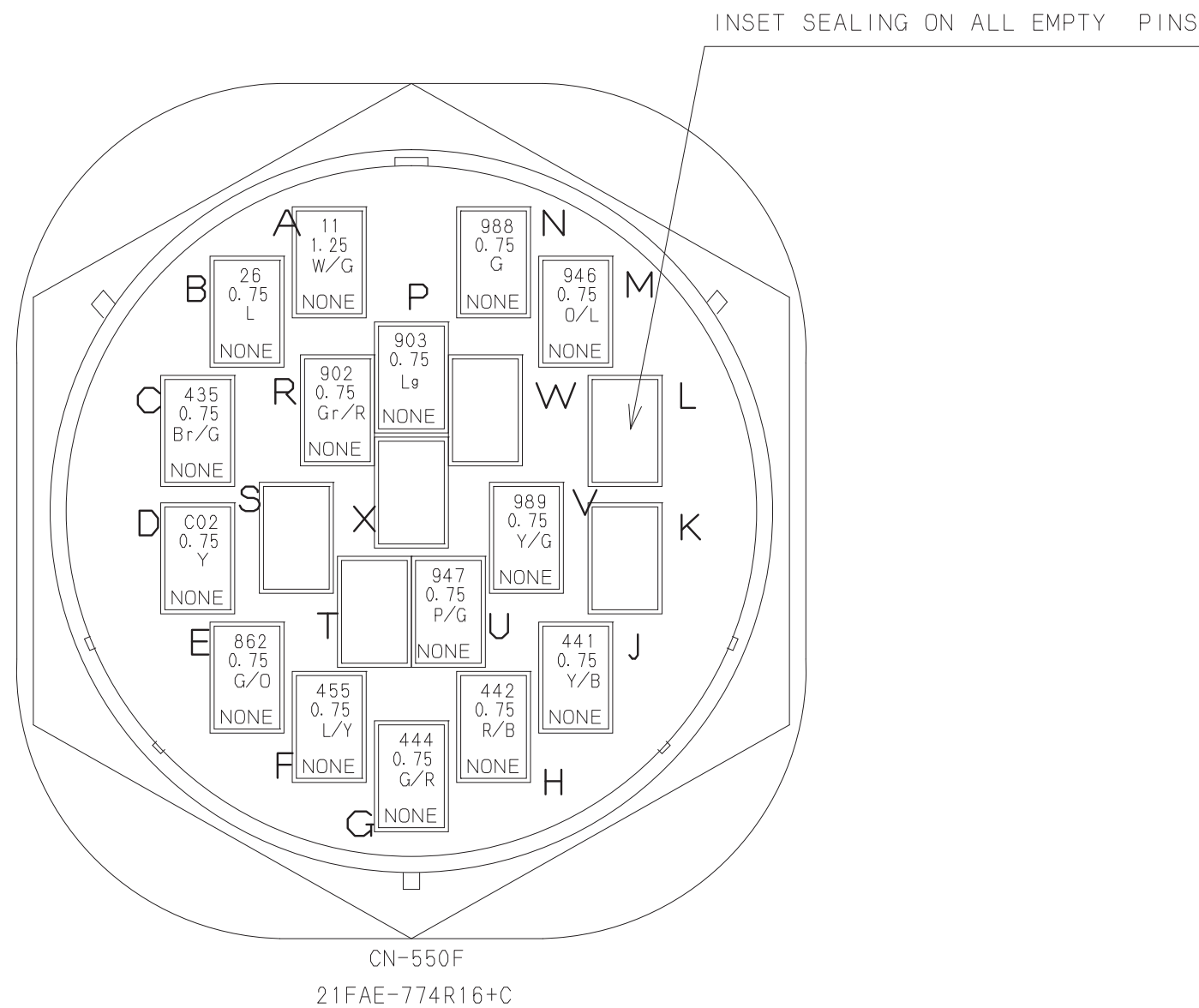

10. ELECTRIC SYSTEM

WIRE No. AND WIRE COLER LIST

WIRE No.	COLER	TYPE	SIZE	F R O M	2-WIRE CLAMP No.	CONNECTION	2-WIRE CLAMP No.	TO
11	W/G	AVSS	1.25	CN-412M		—————		CN-550F
26	L	AVSS	0.75	CN-412M		—————		CN-550F
435	Br/G	AVSS	0.75	CN-413M		—————		CN-550F
441	Y/B	AVSS	0.75	CN-412M		—————		CN-550F
442	R/B	AVSS	0.75	CN-412M		—————		CN-550F
444	G/R	AVSS	0.75	CN-412M		—————		CN-550F
455	L/Y	AVSS	0.75	CN-412M		—————		CN-550F
862	G/O	AVSS	0.75	CN-412M		—————		CN-550F
902	Gr/R	AVSS	0.75	CN-413M		—————		CN-550F
903	Lg	AVSS	0.75	CN-413M		—————		CN-550F
946	O/L	AVSS	0.75	CN-413M		—————		CN-550F
947	P/G	AVSS	0.75	CN-413M		—————		CN-550F
988	G	AVSS	0.75	CN-413M		—————		CN-550F
989	Y/G	AVSS	0.75	CN-413M		—————		CN-550F
C02	Y	AVSS	0.75	CN-412M		—————		CN-550F

11. OVER LOAD PREVENT (M. MACHINERY)

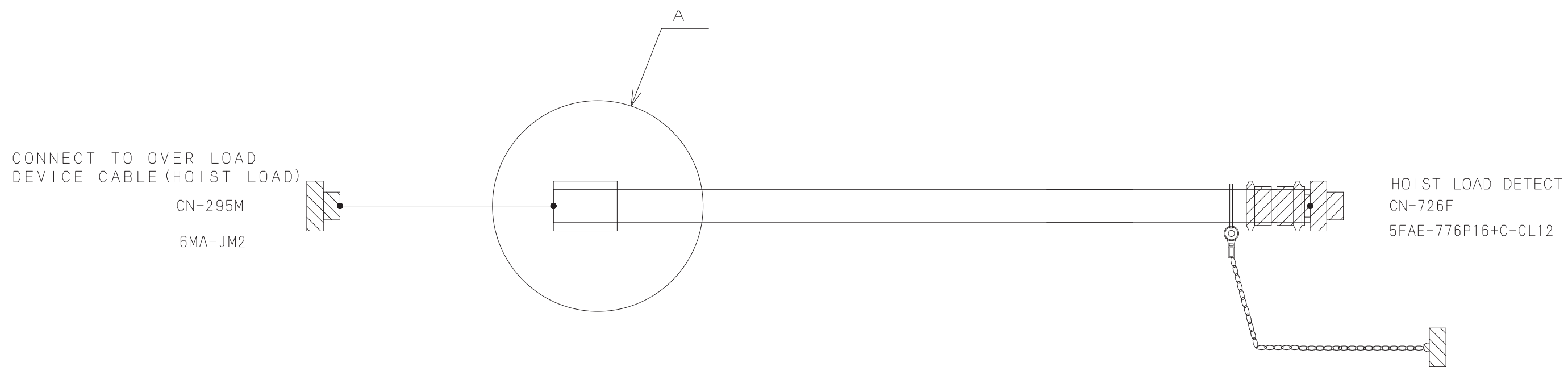

10. ELECTRIC SYSTEM

INSET SEALING ON ALL EMPTY PINS.

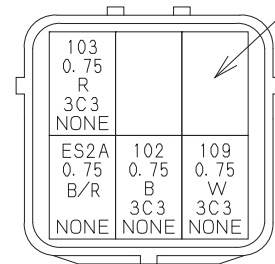

CN-295M
6MA-JM2

SEALING

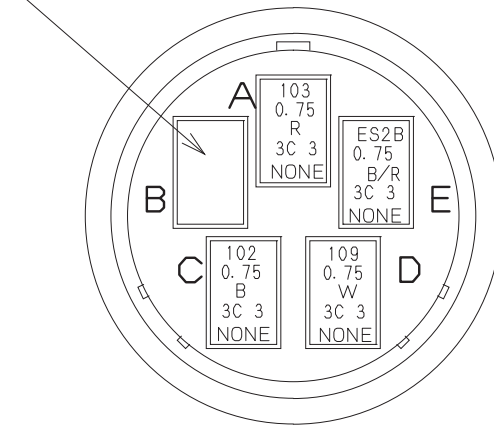

CN-726F
5FAE-776P16+C-CL12

WIRE No. AND WIRE COLER LIST

WIRE No.	COLER	TYPE	SIZE	F R O M	PIN No.	DISTINGUISH SYMBOL	2-WIRE CLAMP No.	CONNECTION	2-WIRE CLAMP No.	DISTINGUISH SYMBOL	PIN No.	TO
102	B	2PNCT-SB	0.75	CN-295M	5	3C3				3C3	3	CN-726F
103	R	2PNCT-SB	0.75	CN-295M	3	3C3				3C3	1	CN-726F
109	W	2PNCT-SB	0.75	CN-295M	4	3C3				3C3	4	CN-726F
ES2A	B/R	AVSS	0.75	CN-295M	6	3C3				3C3		(CN-726F)
ES2B	B/R	AVSS	0.75	(CN-295M)		3C3				3C3	5	CN-726F

12. ELECTRICAL PART OF TRANS LIFTER (OPTION)

SOL : SOLENOID VALVE
 SW : SWITCH
 PSW : PRESSURE SWITCH
 ATT : ATTACHMENT
 C/W : COUNTER WEIGHT
 CB/W : CARBODY WEIGHT

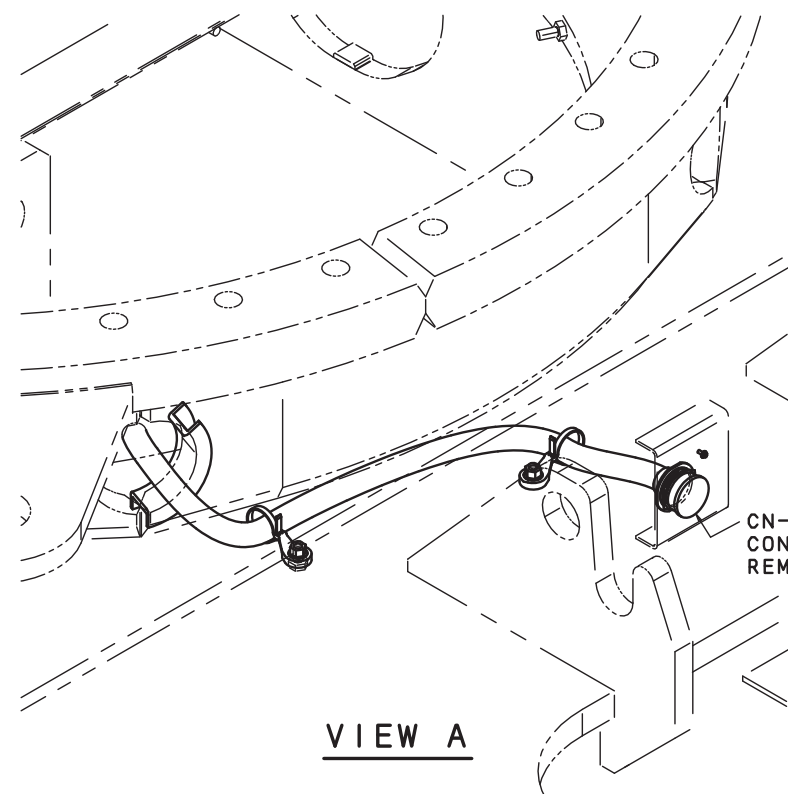

VIEW A

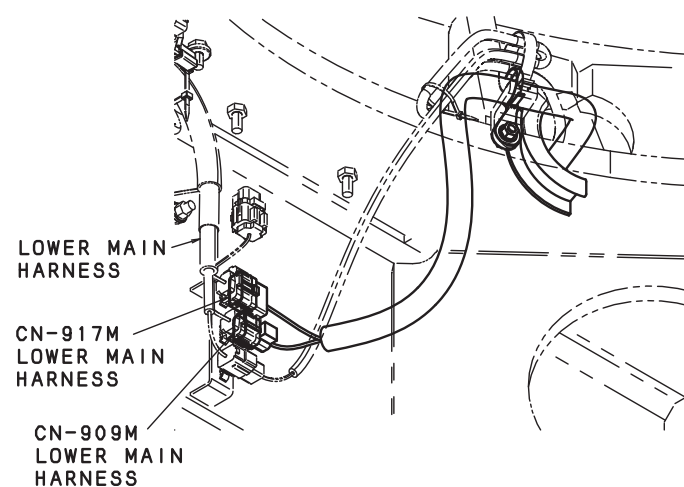
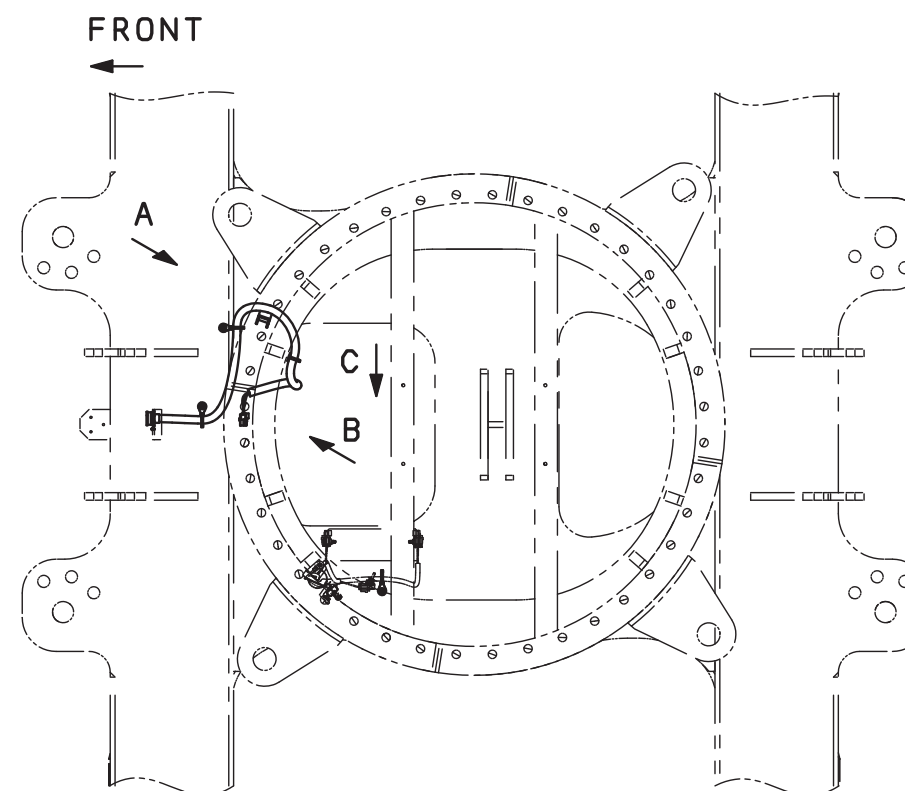

VIEW B

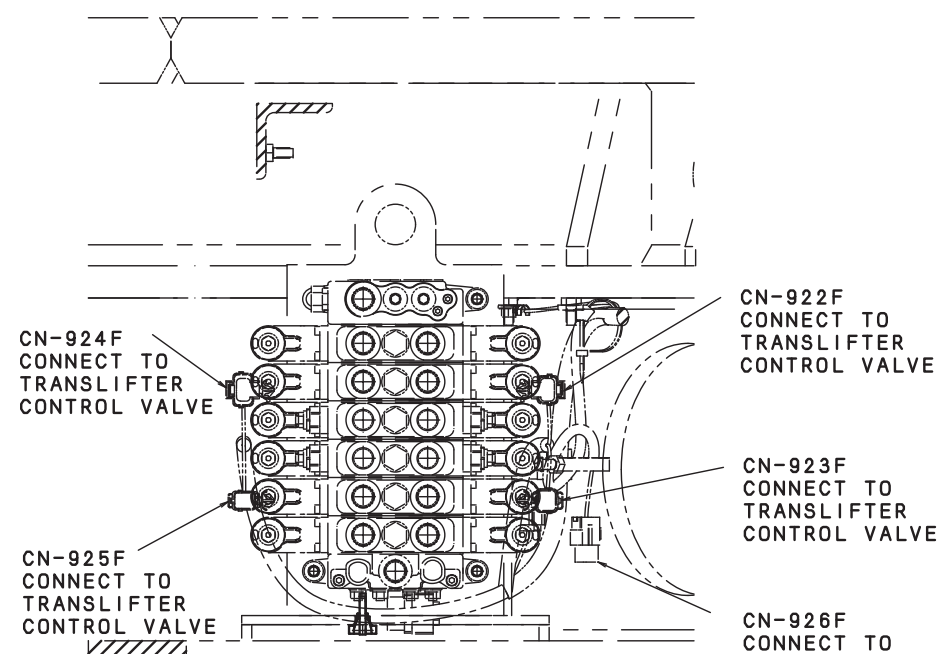

VIEW C

10. ELECTRIC SYSTEM

14. ELECTRICAL PART OF HYDRAULIC OIL HEAT

SOL : SOLENOID VALVE
SW : SWITCH
PSW : PRESSURE SWITCH
ATT. : ATTACHMENT
C/W : COUNTER WEIGHT
CB/W : CARBODY WEIGHT

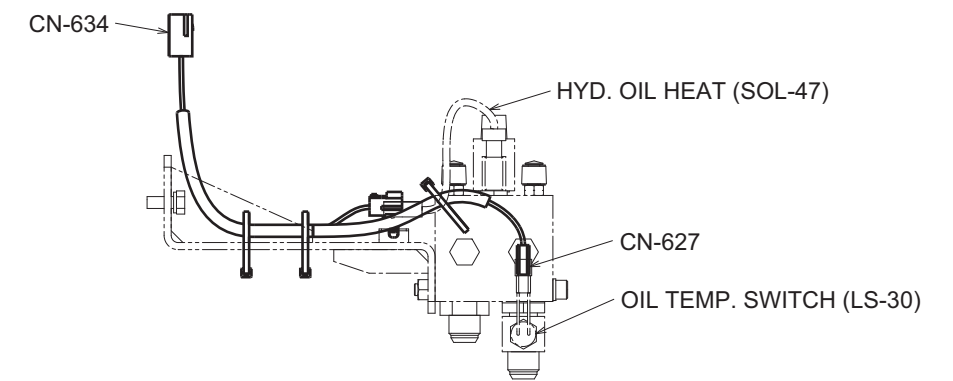
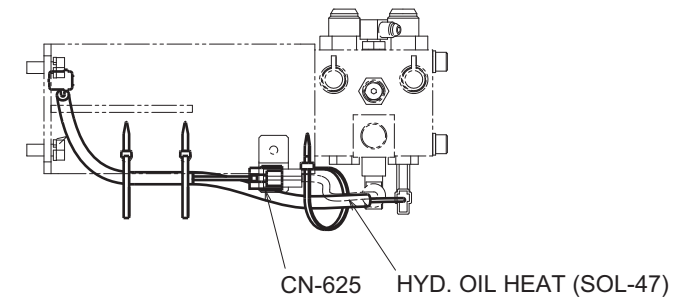
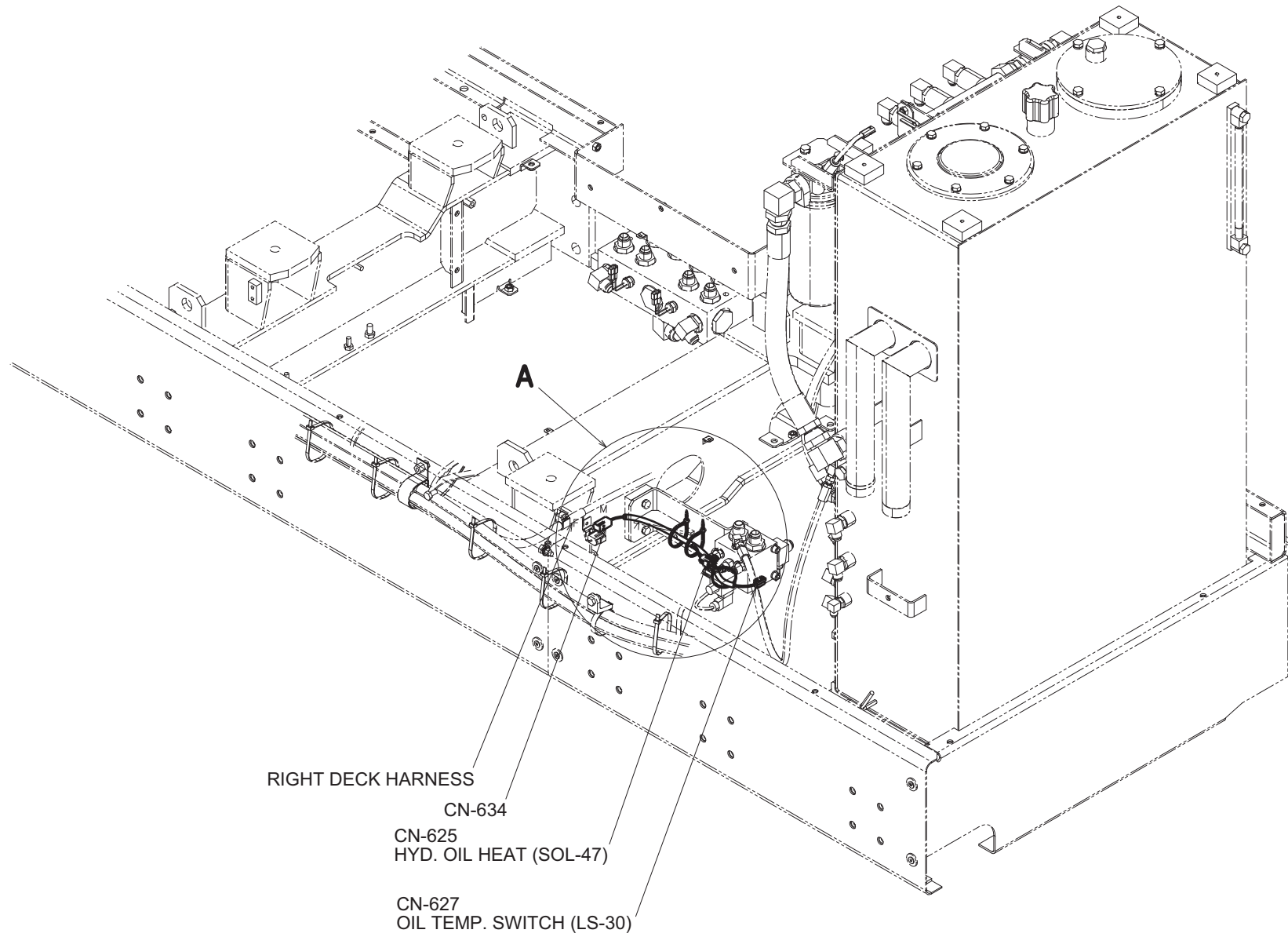

DETAIL OF "A"

HYDRAULIC OIL HEAT HARNESS

only

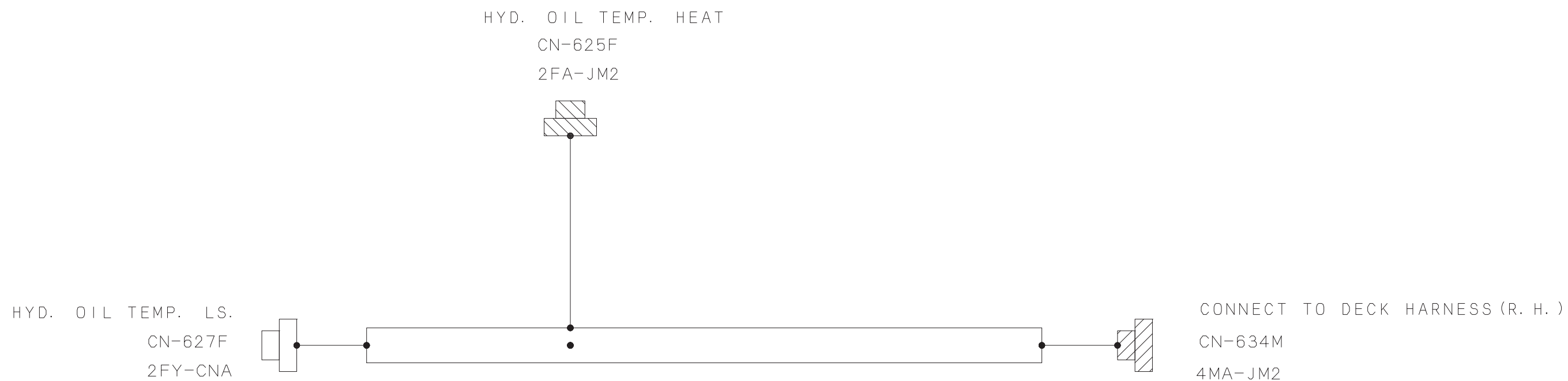

Refer

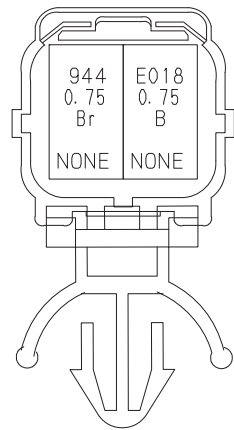

CN-625F
2FA-JM2

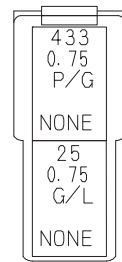

CN-627F
2FY-CNA

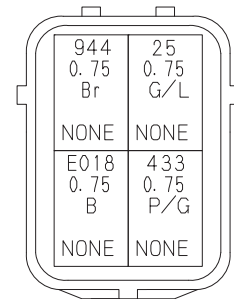

CN-634M
4MA-JM2

WIRE No. AND WIRE COLER LIST

WIRE No.	COLER	TYPE	SIZE	F R O M	PIN No.	DISTINGUISH SYMBOL	2-WIRE CLAMP No.	CONNECTION	2-WIRE CLAMP No.	DISTINGUISH SYMBOL	PIN No.	TO	LENGTH (mm)
25	G/L	AVSS	0.75	CN-627F	1			_____			1	CN-634M	440
433	P/G	AVSS	0.75	CN-627F	2			_____			3	CN-634M	440
944	Br	AVSS	0.75	CN-625F	1			_____			2	CN-634M	350
E018	B	AVSS	0.75	CN-634M	4			_____			2	CN-625F	350

15. ELECTRICAL PART OF BOOM BASE (INSERT INCLUDED)

SOL : SOLENOID VALVE
 SW : SWITCH
 PSW : PRESSURE SWITCH
 ATT. : ATTACHMENT
 CW : COUNTER WEIGHT
 CBW : CARBODY WEIGHT

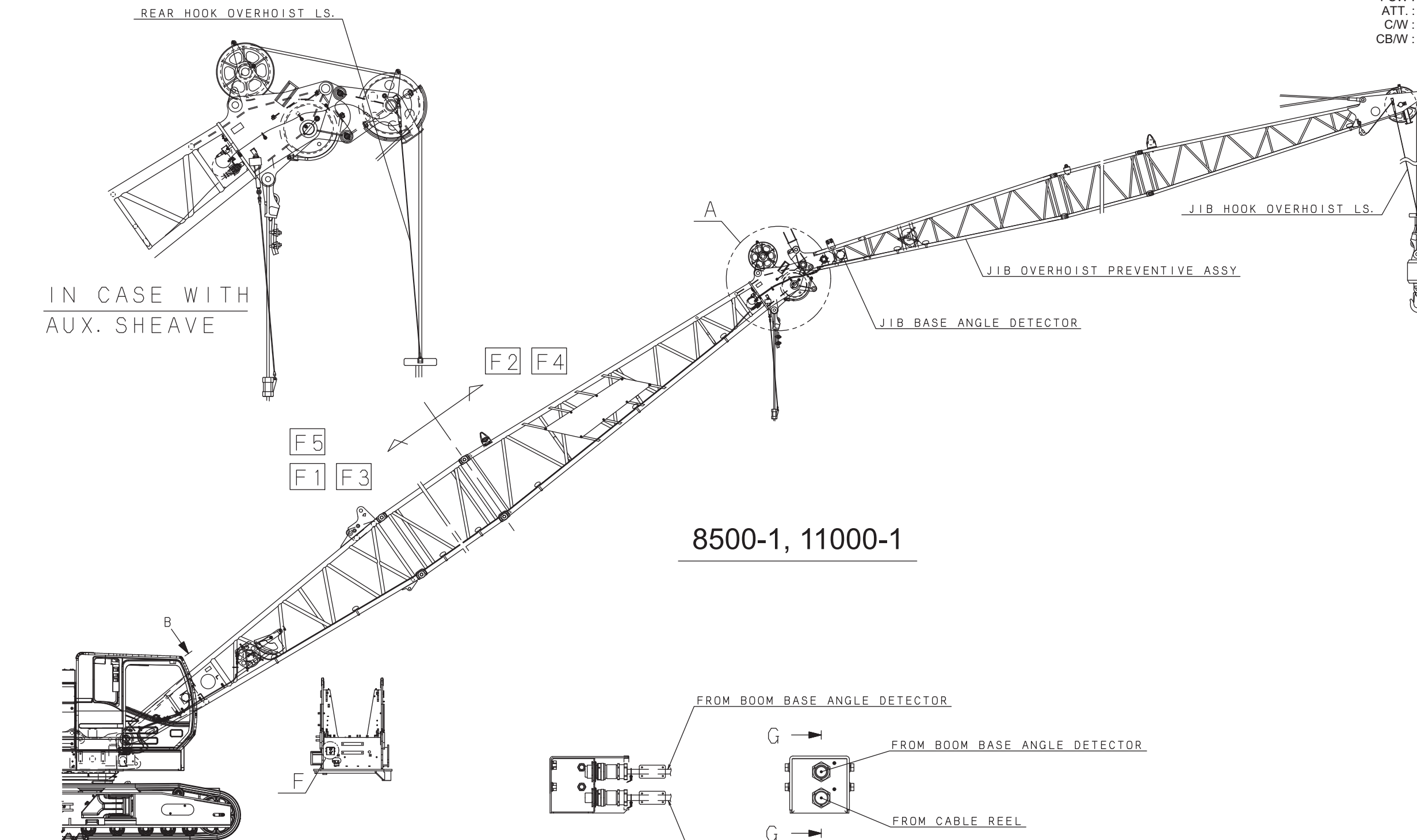

SOL : SOLENOID VALVE
 SW : SWITCH
 PSW : PRESSURE SWITCH
 ATT. : ATTACHMENT
 C/W : COUNTER WEIGHT
 CB/W : CARBODY WEIGHT

8500-1, 11000-1

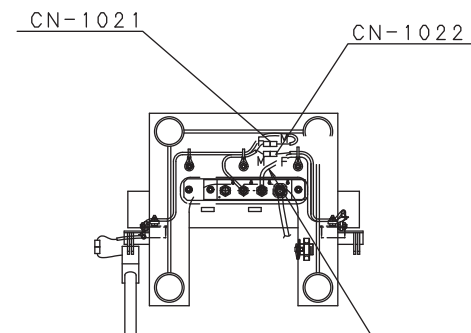
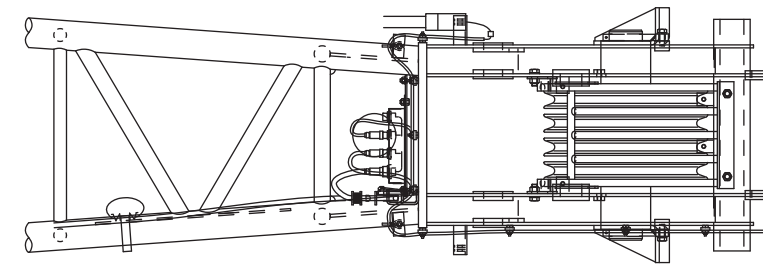
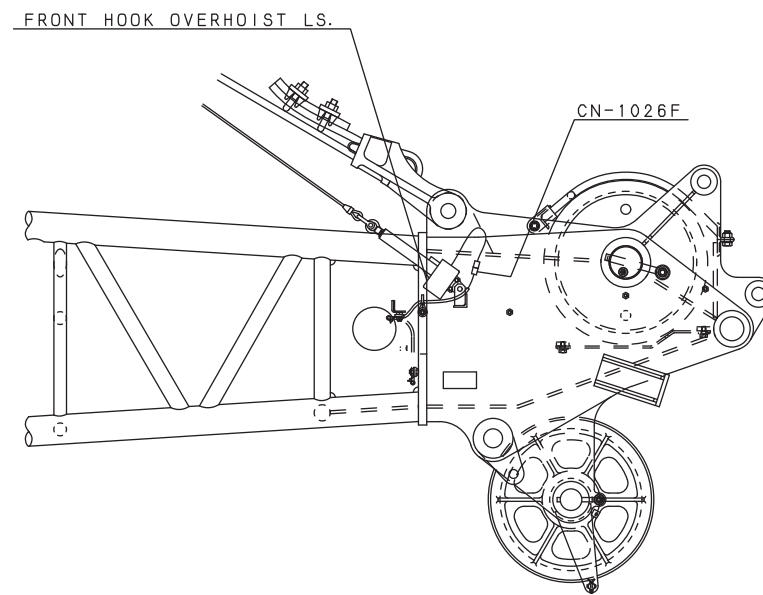

CONNECT TO JIB BASE ANGLE DETECTOR

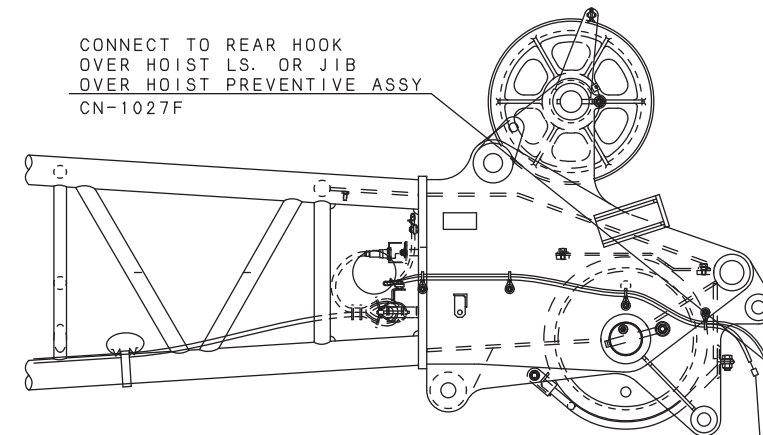

SOL : SOLENOID VALVE
 SW : SWITCH
 PSW : PRESSURE SWITCH
 ATT. : ATTACHMENT
 CW : COUNTER WEIGHT
 CBW : CARBODY WEIGHT

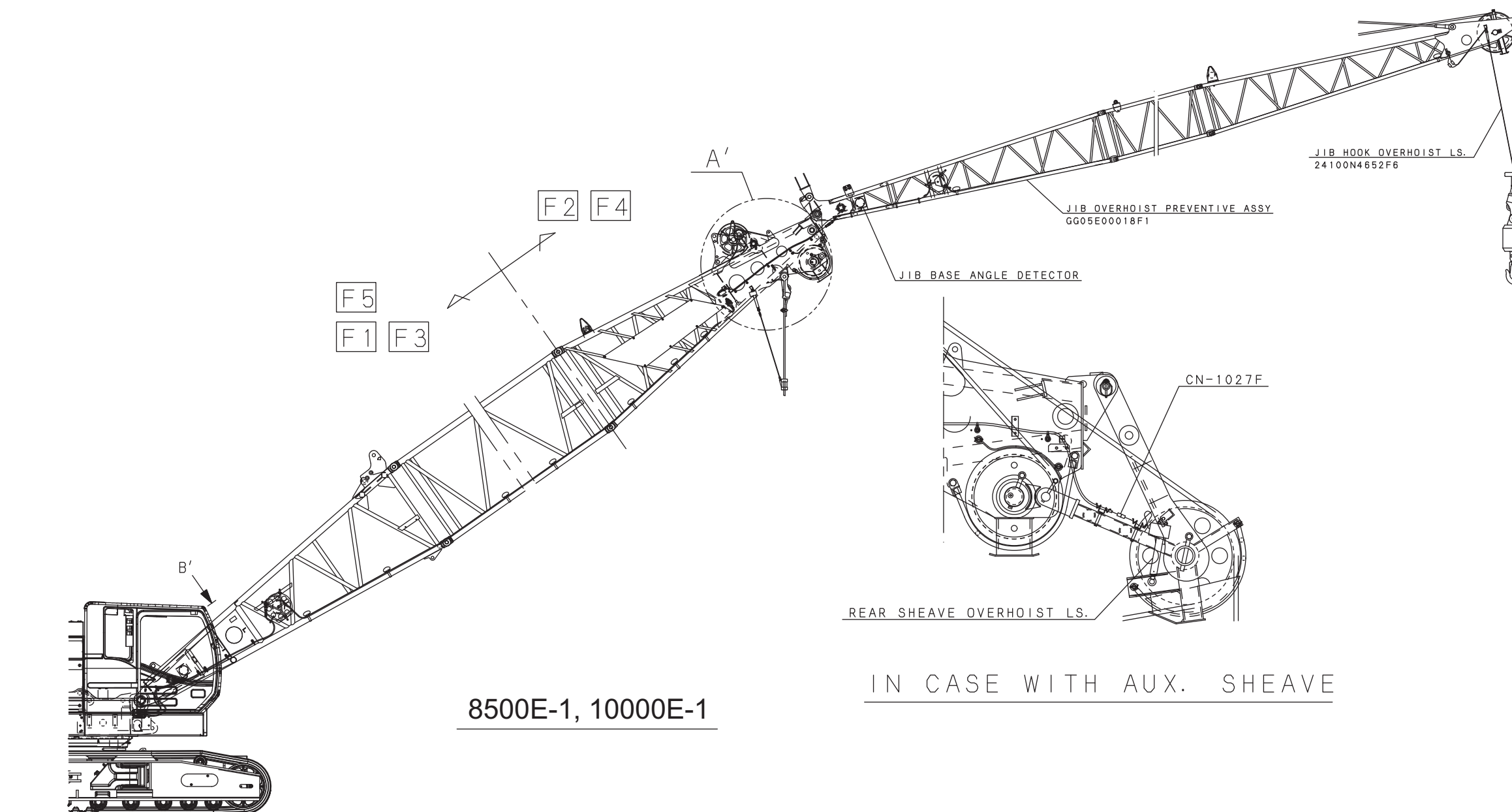

8500E-1, 10000E-1

SOL : SOLENOID VALVE
 SW : SWITCH
 PSW : PRESSURE SWITCH
 ATT : ATTACHMENT
 C/W : COUNTER WEIGHT
 CBW : CARBODY WEIGHT

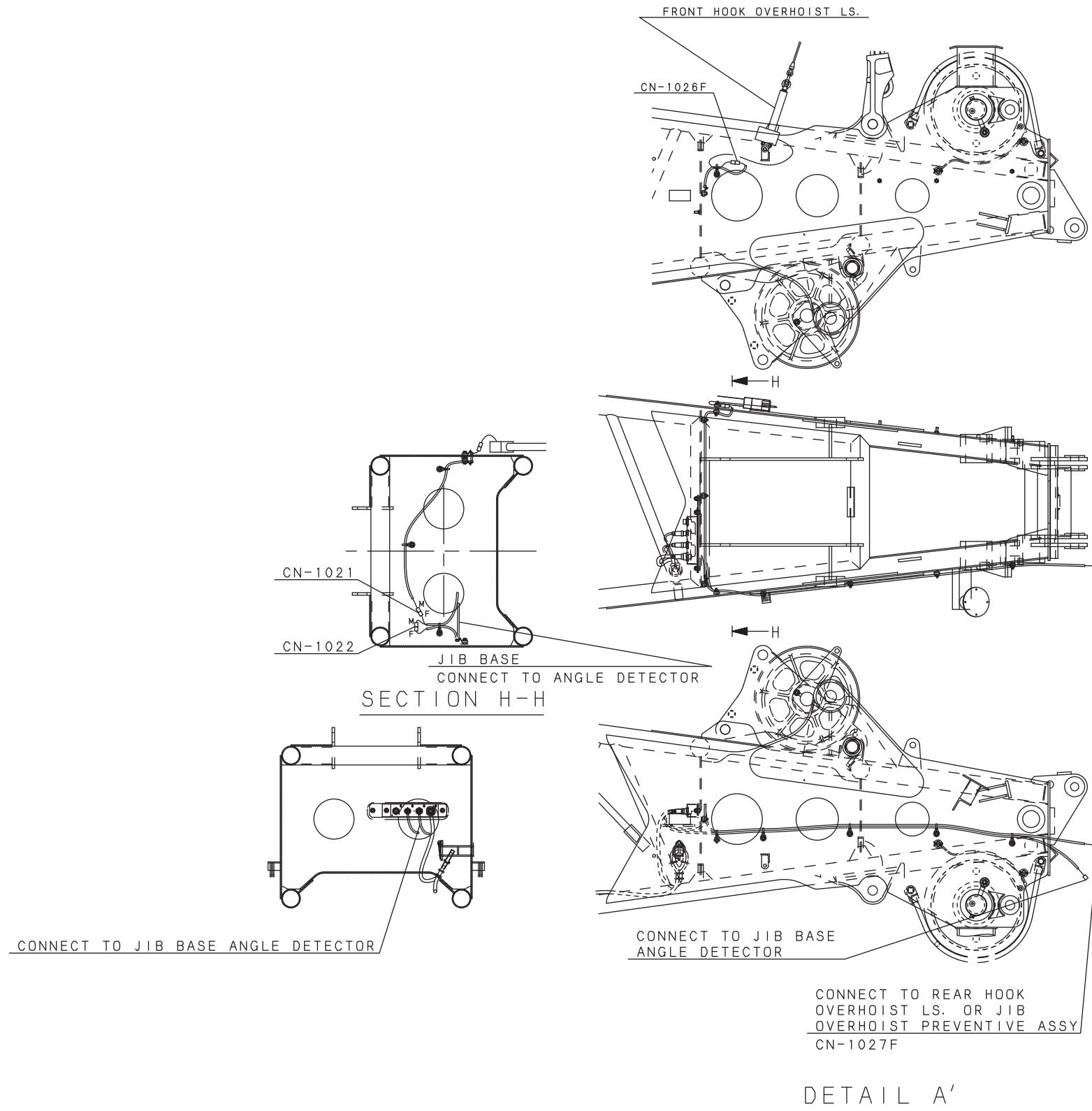

SOL : SOLENOID VALVE
 SW : SWITCH
 PSW : PRESSURE SWITCH
 ATT. : ATTACHMENT
 C/W : COUNTER WEIGHT
 CB/W : CARBODY WEIGHT

(DETAIL UPPER BOOM)

FRONT HOOK OVERHOIST LS.
 GG51E00011F4

CN-1026F

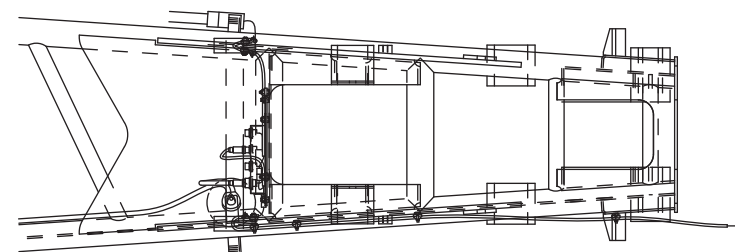
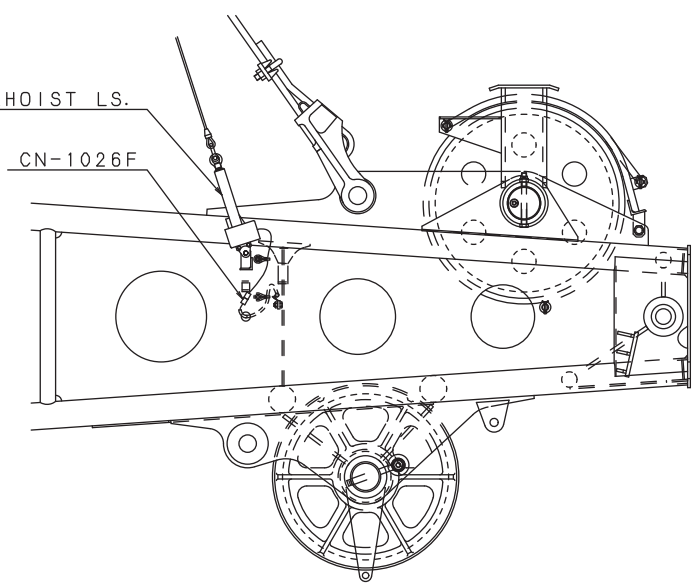

NAME PLATE SIDE

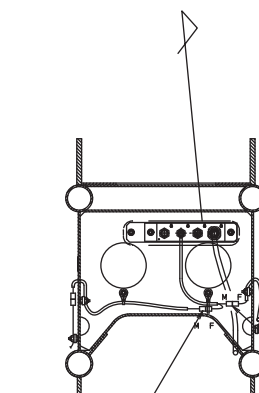

CN-1022

CN-1021

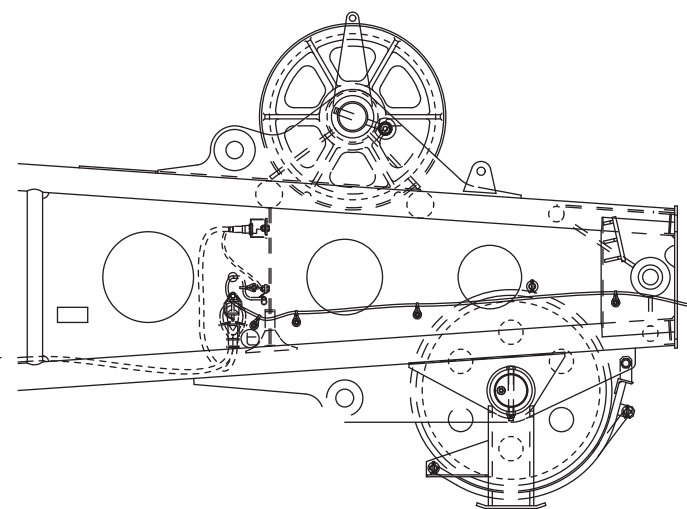

CONNECT TO REAR HOOK
 OVER HOIST L. S. OR
 JIB OVERHOIST PREVENTIVE ASSY
 CN-1027F

DETAIL A'



Reference Only

10. ELECTRIC SYSTEM

SOL : SOLENOID VALVE
 SW : SWITCH
 PSW : PRESSURE SWITCH
 ATT. : ATTACHMENT
 C/W : COUNTER WEIGHT
 CB/W : CARBODY WEIGHT

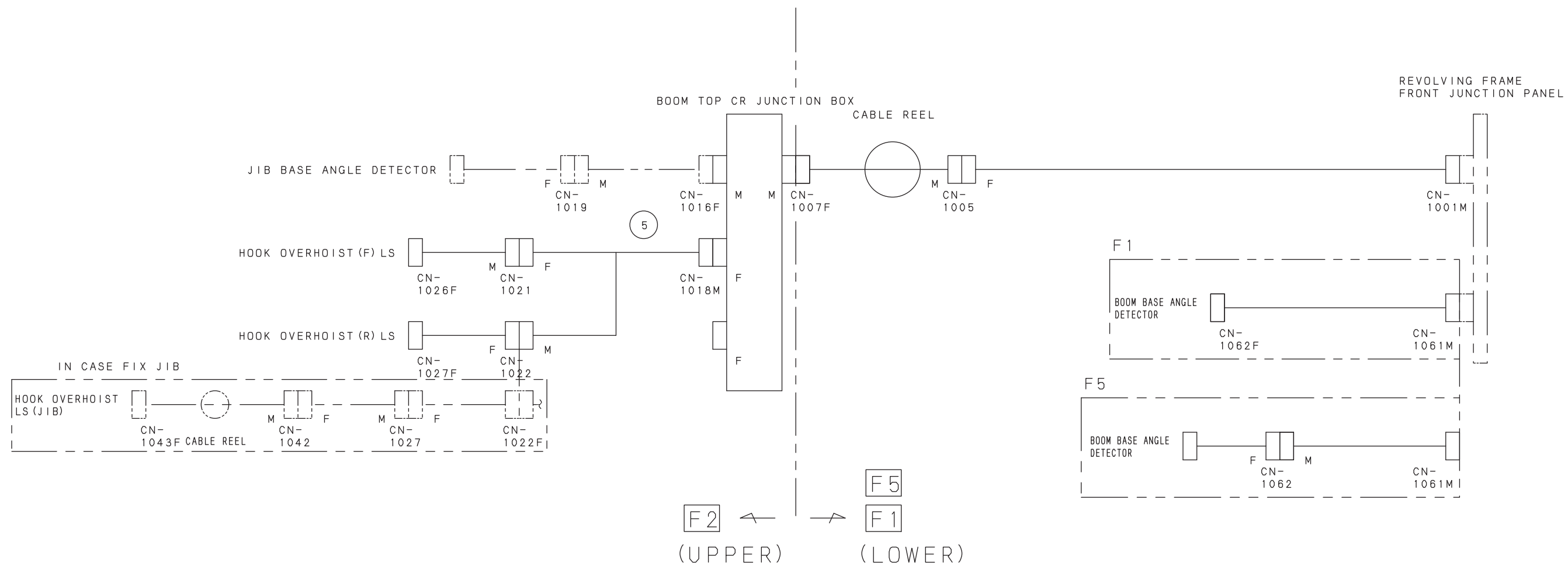

SOL : SOLENOID VALVE
 SW : SWITCH
 PSW : PRESSURE SWITCH
 ATT. : ATTACHMENT
 C/W : COUNTER WEIGHT
 CB/W : CARBODY WEIGHT

8500-1, 11000-1

8500E-1, 10000E-1

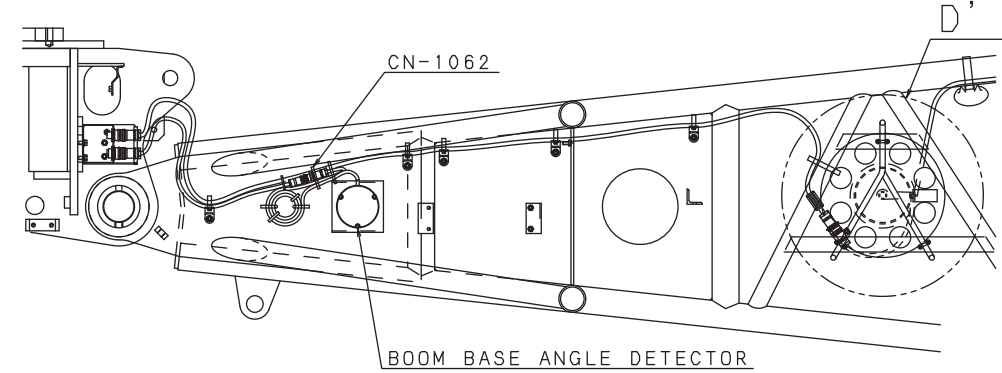
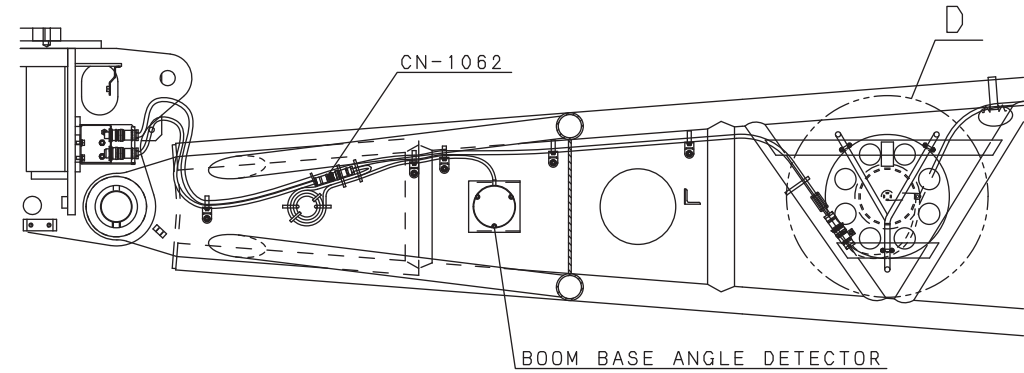

SECTION C-C

SECTION C'-C'

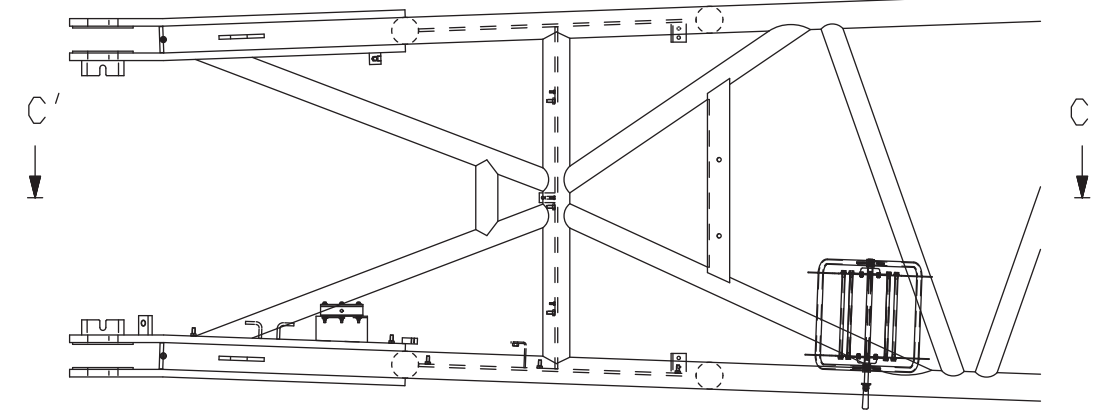
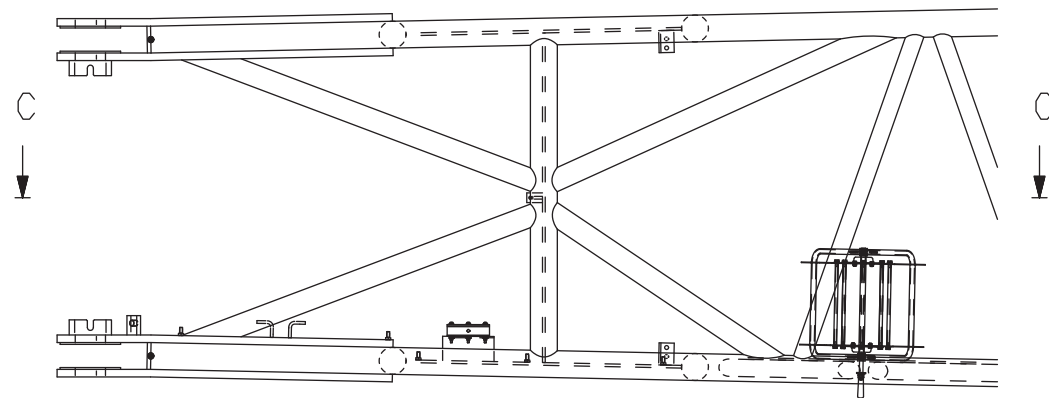

VIEW B

VIEW B'

FROM REVOLVING FRAME FRONT
 JUNCTION BOX

FROM REVOLVING FRAME FRONT
 JUNCTION BOX

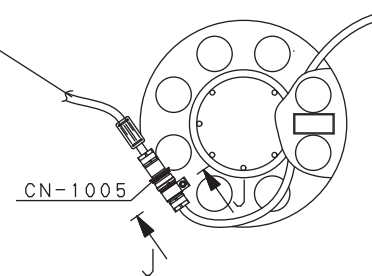
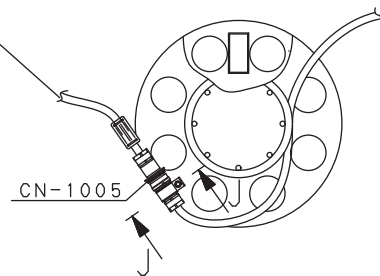

DETAIL D

DETAIL D'

Reference Only

10. ELECTRIC SYSTEM

BOOM BASE HARNESS (INSERT INCLUDED)

TO JUNCTION BOX
(UPPER BOOM) (CABLE REEL)
CN-1005F
11FAE-774R16+C-CL16



CONNECT TO JUNCTION BOX
(SWING FRAME (FRONT))
CN-1001M
11MAE-776P16+C-CL16

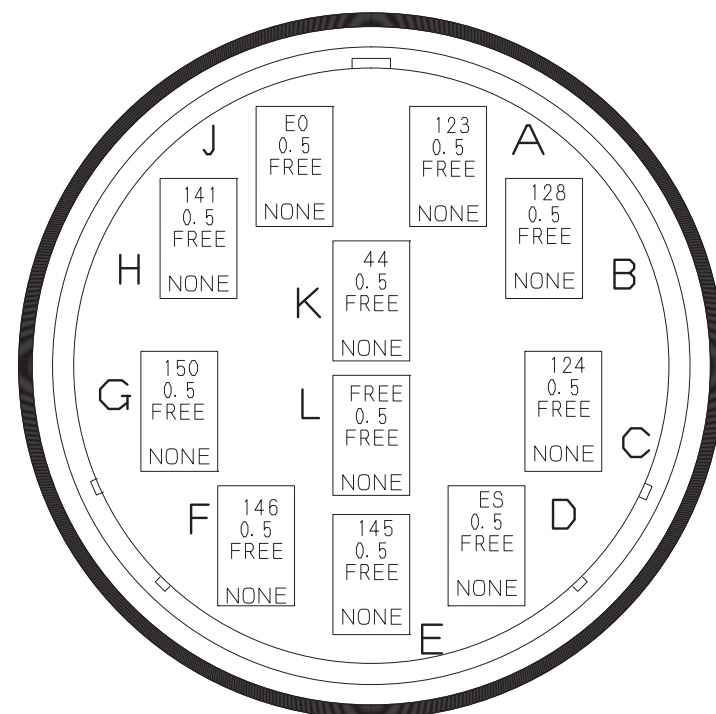

CN-1001M
11MAE-776P16+C-CL16

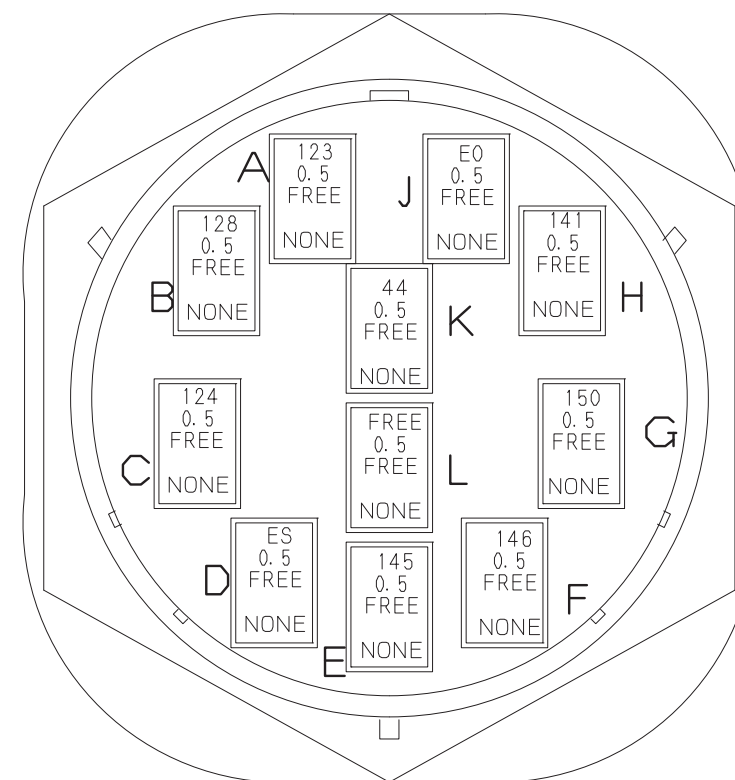

CN-1005F
11FAE-774R16+C-CL16

WIRE No. AND WIRE COLER LIST

WIRE No.	COLER	TYPE	SIZE	F R O M	PIN No.	2-WIRE CLAMP No.	CONNECTION	2-WIRE CLAMP No.	PIN No.	TO
44	Free	2PNCT-SB	0.5	CN-1005F	10				10	CN-1001M
123	Free	2PNCT-SB	0.5	CN-1005F	1				1	CN-1001M
124	Free	2PNCT-SB	0.5	CN-1005F	3				3	CN-1001M
128	Free	2PNCT-SB	0.5	CN-1005F	2				2	CN-1001M
141	Free	2PNCT-SB	0.5	CN-1005F	8				8	CN-1001M
145	Free	2PNCT-SB	0.5	CN-1005F	5				5	CN-1001M
146	Free	2PNCT-SB	0.5	CN-1005F	6				6	CN-1001M
150	Free	2PNCT-SB	0.5	CN-1005F	7				7	CN-1001M
E0	Free	2PNCT-SB	0.5	CN-1005F	9				9	CN-1001M
FREE	Free	2PNCT-SB	0.5	CN-1005F	11				11	CN-1001M
ES	Free	SHIELD		CN-1005F	4					(CN-1001M)
ES	Free	SHIELD		(CN-1005F)					4	CN-1001M

10. ELECTRIC SYSTEM

CABLE

CONNECT TO JUNCTION BOX
(UPPER BOOM)
CN-1007F
11FAE-776P16+C-CL16



TO JUNCTION BOX
(SWING FRAME) (CABLE REEL)
CN-1005M
11MAE-776P16+C-CL16

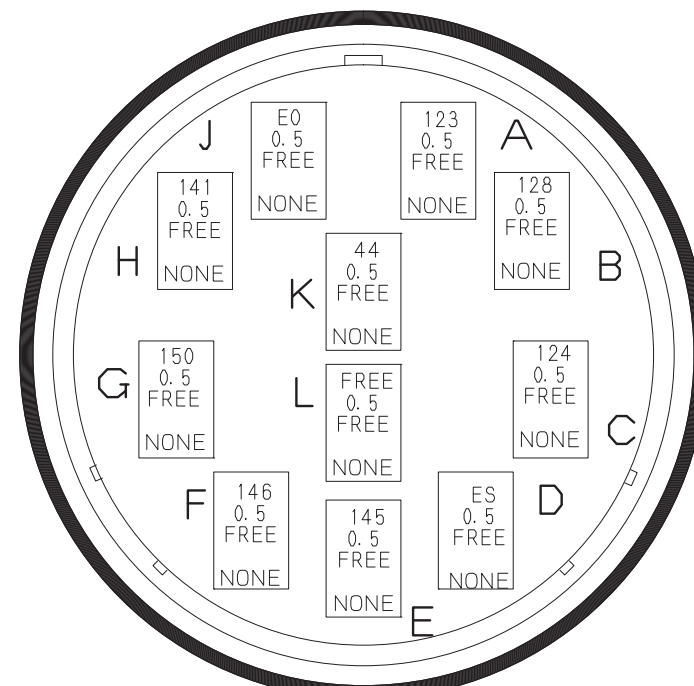

CN-1005M
11MAE-776P16+C-CL16

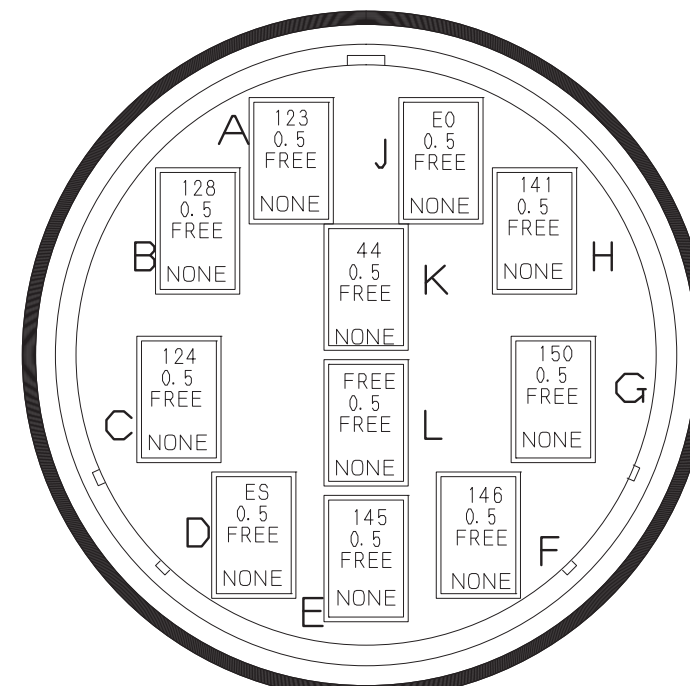

CN-1007F
11FAE-776P16+C-CL16

WIRE No. AND WIRE COLER LIST

WIRE No.	COLER	TYPE	SIZE	F R O M	PIN No.	2-WIRE CLAMP No.	CONNECTION	2-WIRE CLAMP No.	PIN No.	TO
44	Free	2PNCT-SB	0.5	CN-1007F	10				10	CN-1005M
123	Free	2PNCT-SB	0.5	CN-1007F	1			1	CN-1005M	
124	Free	2PNCT-SB	0.5	CN-1007F	3			3	CN-1005M	
128	Free	2PNCT-SB	0.5	CN-1007F	2			2	CN-1005M	
141	Free	2PNCT-SB	0.5	CN-1007F	8			8	CN-1005M	
145	Free	2PNCT-SB	0.5	CN-1007F	5			5	CN-1005M	
146	Free	2PNCT-SB	0.5	CN-1007F	6			6	CN-1005M	
150	Free	2PNCT-SB	0.5	CN-1007F	7			7	CN-1005M	
E0	Free	2PNCT-SB	0.5	CN-1007F	9			9	CN-1005M	
FREE	Free	2PNCT-SB	0.5	CN-1007F	11			11	CN-1005M	
ES	Free	SHIELD		CN-1007F	4				(CN-1005M)	
ES	Free	SHIELD		(CN-1007F)				4	CN-1005M	

10. ELECTRIC SYSTEM

16. BOOM TIP HARNESS



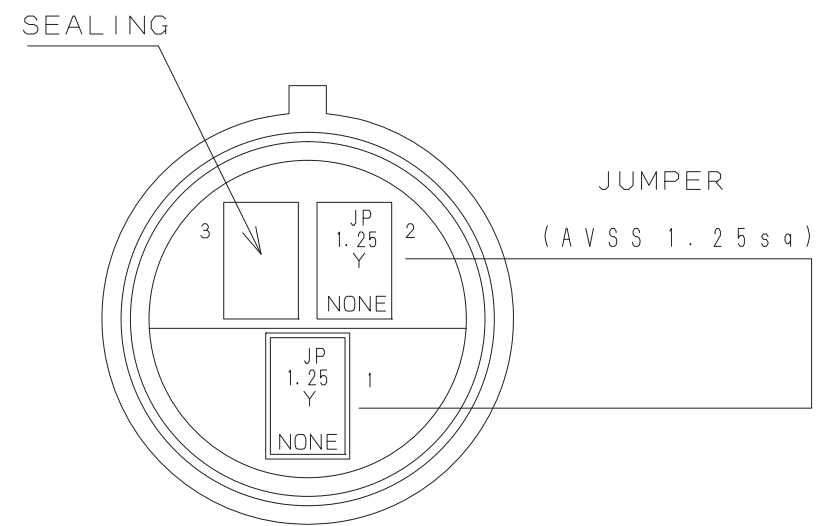

CN-1021AF
3FC-SSR

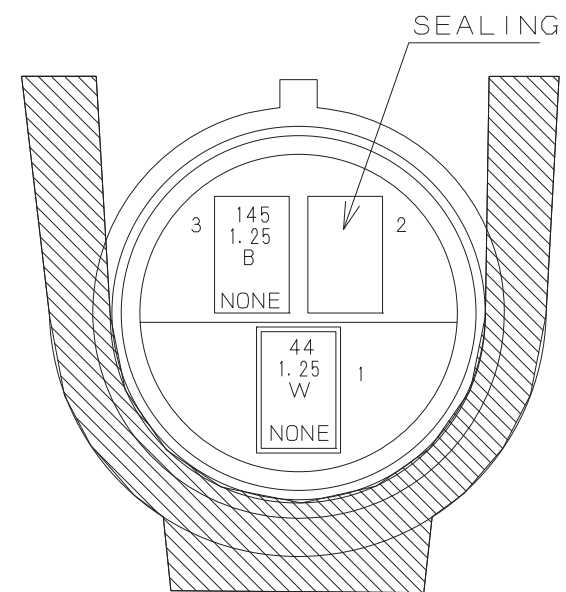

CN-1026F
3FC-SSR

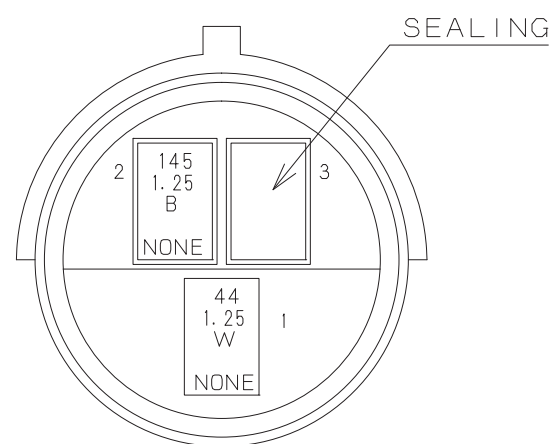

CN-1021M
3MC-SSP

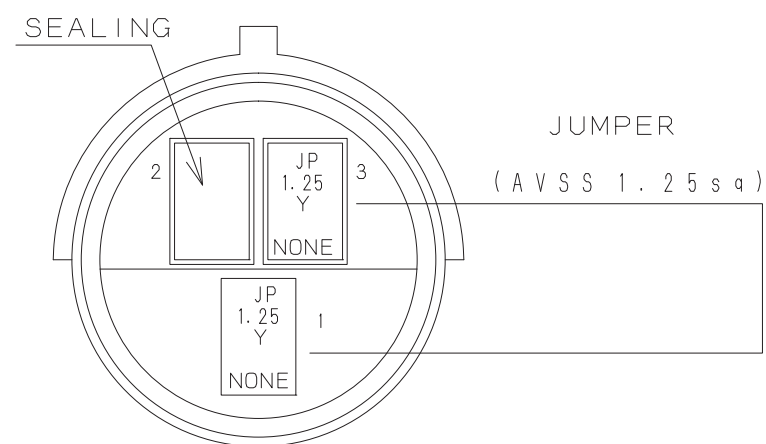

CN-1026AM
3MC-SSP

WIRE No. AND WIRE COLOR LIST

No.	COLOR	TYPE	SIZE	F R O M	DISTINGUISH SYMBOL	2-WIRE CLAMP No.	CONNECTION	2-WIRE CLAMP No.	DISTINGUISH SYMBOL	T O
44	W	VCTF	1.25	CN-1021M						CN-1026F
145	B	VCTF	1.25	CN-1021M						CN-1026F
JP	Y	AVSS	1.25	CN-1021AF						CN-1021AF
JP	Y	AVSS	1.25							CN-1021AF
JP	Y	AVSS	1.25	CN-1026AM						
JP	Y	AVSS	1.25							CN-1026AM

10. ELECTRIC SYSTEM

CABLE

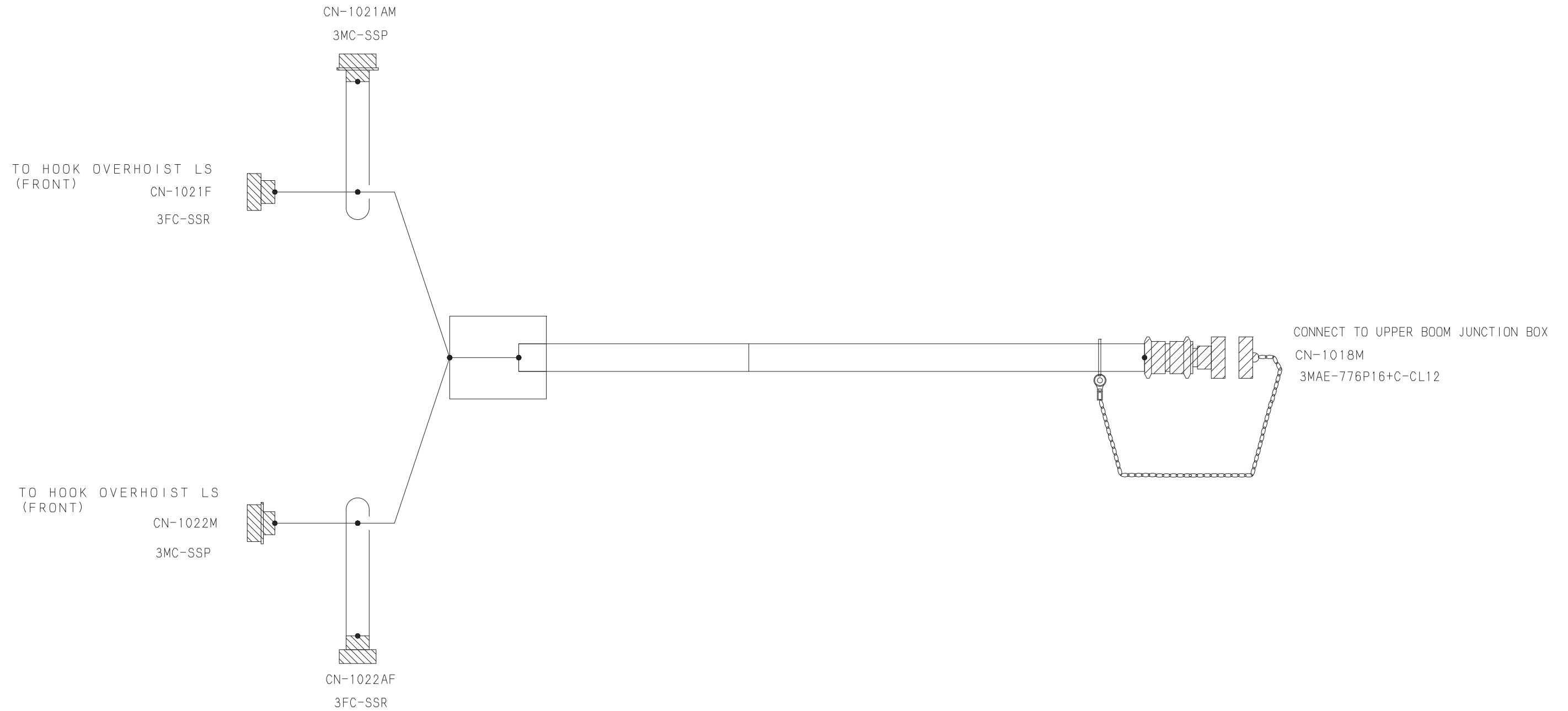

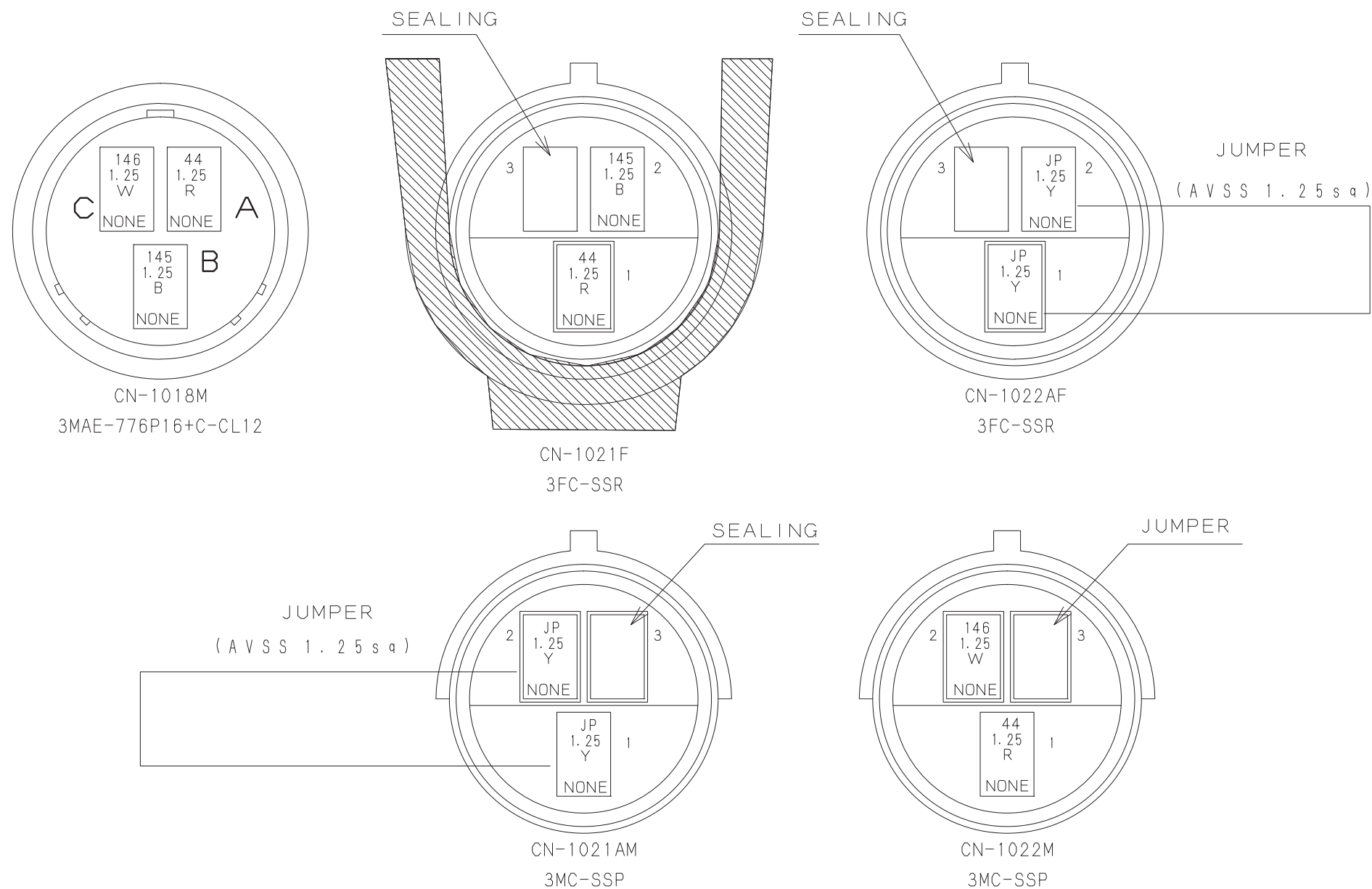

WIRE No. AND WIRE COLER LIST

No.	COLER	TYPE	SIZE	F R O M	DISTINGUISH SYMBOL	2-WIRE CLAMP No.	CONNECTION	2-WIRE CLAMP No.	DISTINGUISH SYMBOL	TO
44	R	AVSS	1.25	CN-1021F			=====			JS
44	R	AVSS	1.25	CN-1022M			=====			JS
44	R	2PNCT-SR	1.25	CN-1018M			=====			JS
145	B	2PNCT-SR	1.25	CN-1021F			=====			CN-1018M
146	W	2PNCT-SR	1.25	CN-1022M			=====			CN-1018M
JP	Y	AVSS	1.25	CN-1021AM			=====			CN-1021AM
JP	Y	AVSS	1.25	CN-1022AF			=====			CN-1022AF

10. ELECTRIC SYSTEM

CABLE

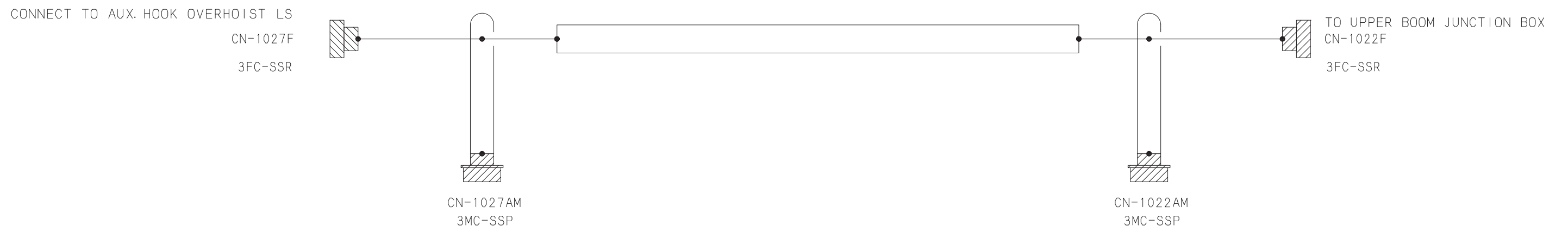

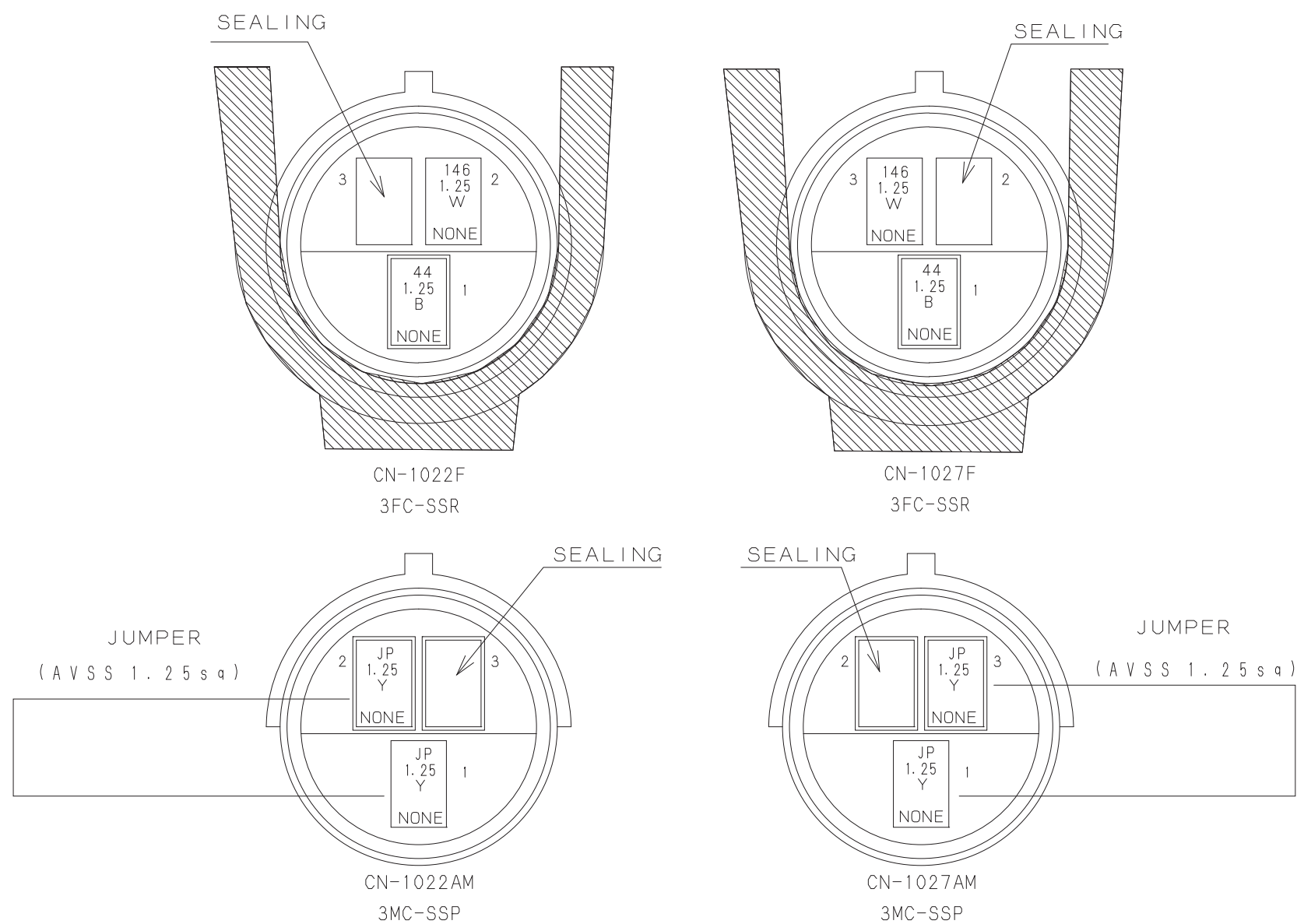

WIRE No. AND WIRE COLER LIST

No.	COLER	TYPE	SIZE	F R O M	DISTINGUISH SYMBOL	2-WIRE CLAMP No.	CONNECTION	2-WIRE CLAMP No.	DISTINGUISH SYMBOL	TO
44	B	VCTF	1.25	CN-1022F			————			CN-1027F
146	W	VCTF	1.25	CN-1022F			————			CN-1027F
JP	Y	AVSS	1.25	CN-1022AM			—┐			CN-1022AM
JP	Y	AVSS	1.25				—┐			CN-1022AM
JP	Y	AVSS	1.25	CN-1027AM			—┐			
JP	Y	AVSS	1.25				—┐			CN-1027AM

10. ELECTRIC SYSTEM

18. ELECTRICAL PART OF FIXED JIB

SOL : SOLENOID VALVE
 SW : SWITCH
 PSW : PRESSURE SWITCH
 ATT. : ATTACHMENT
 C/W : COUNTER WEIGHT
 CB/W : CARBODY WEIGHT

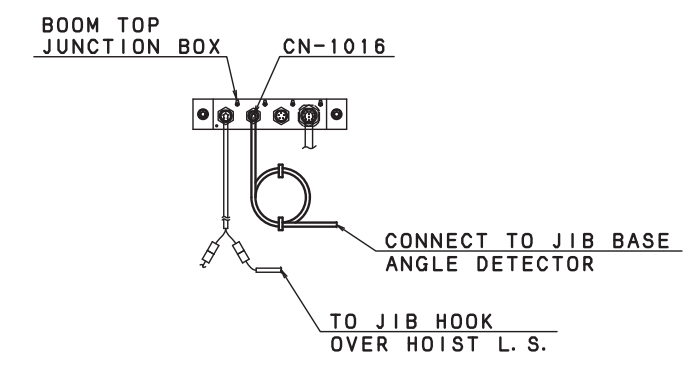
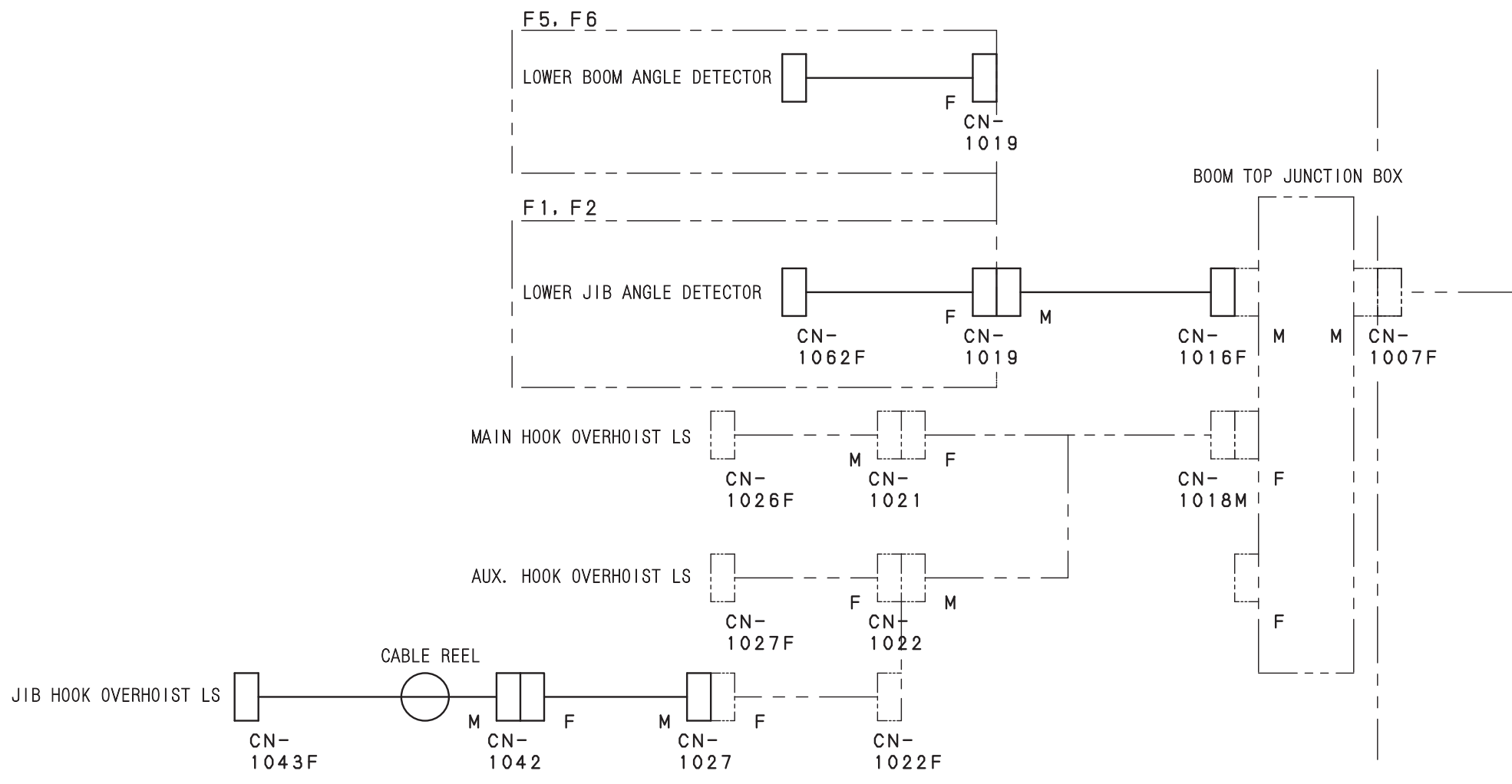
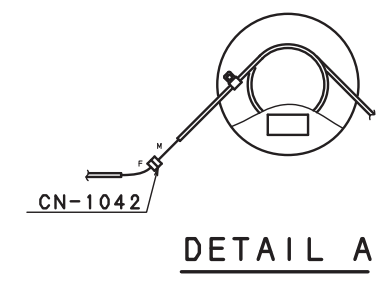
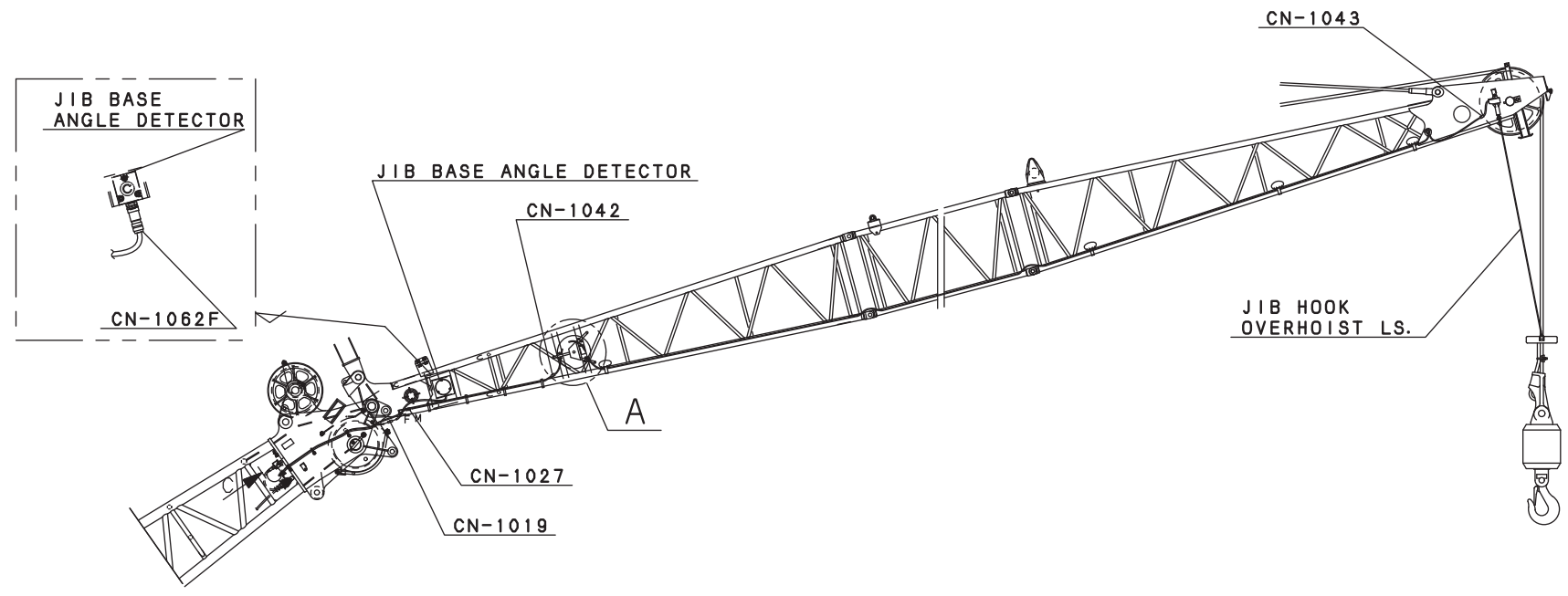

VIEW C

FIXED JIB HARNESS



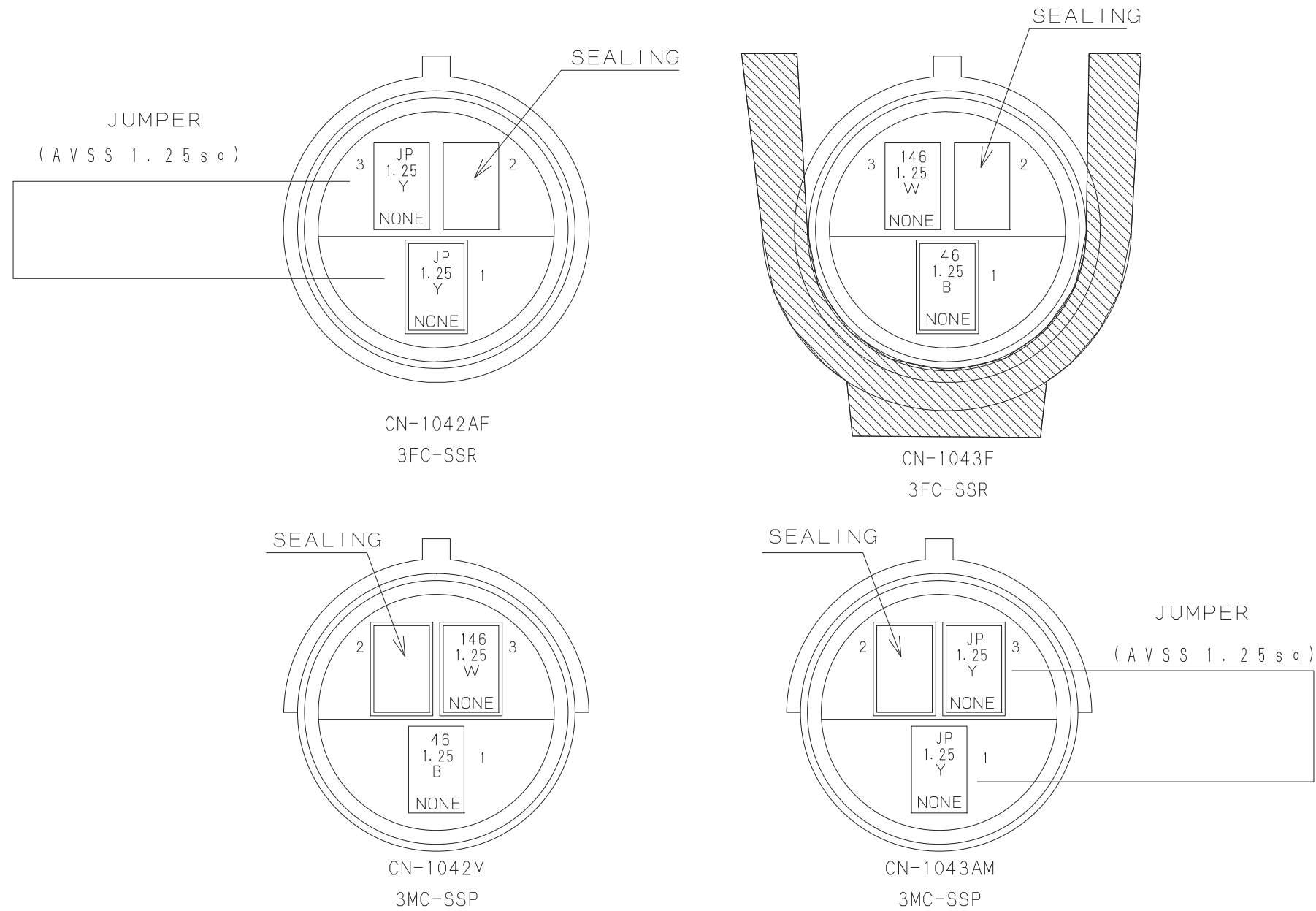

WIRE No. AND WIRE COLER LIST

No.	COLER	TYPE	SIZE	F R O M	DISTINGUISH SYMBOL	2-WIRE CLAMP No.	CONNECTION	2-WIRE CLAMP No.	DISTINGUISH SYMBOL	TO
46	B	VCTF	1.25	CN-1043F			—————			CN-1042M
146	W	VCTF	1.25	CN-1043F			—————			CN-1042M
JP	Y	AVSS	1.25	CN-1042AF			———┐			
JP	Y	AVSS	1.25				———┐			CN-1042AF
JP	Y	AVSS	1.25	CN-1043AM			———┐			
JP	Y	AVSS	1.25				———┐			CN-1043AM

CABLE

CONNECT TO JUNCTION BOX
(AUX. HOOK OVER HOIST LS)

CN-1042F
3FC-SSR

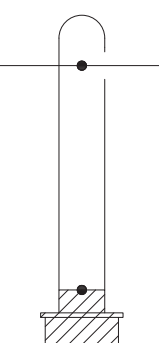

CN-1042AM
3MC-SSP

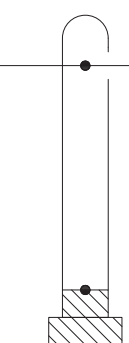

CN-1027AF
3FC-SSR



TO JUNCTION BOX
(UPPER BOOM)

CN-1027M
3MC-SSP

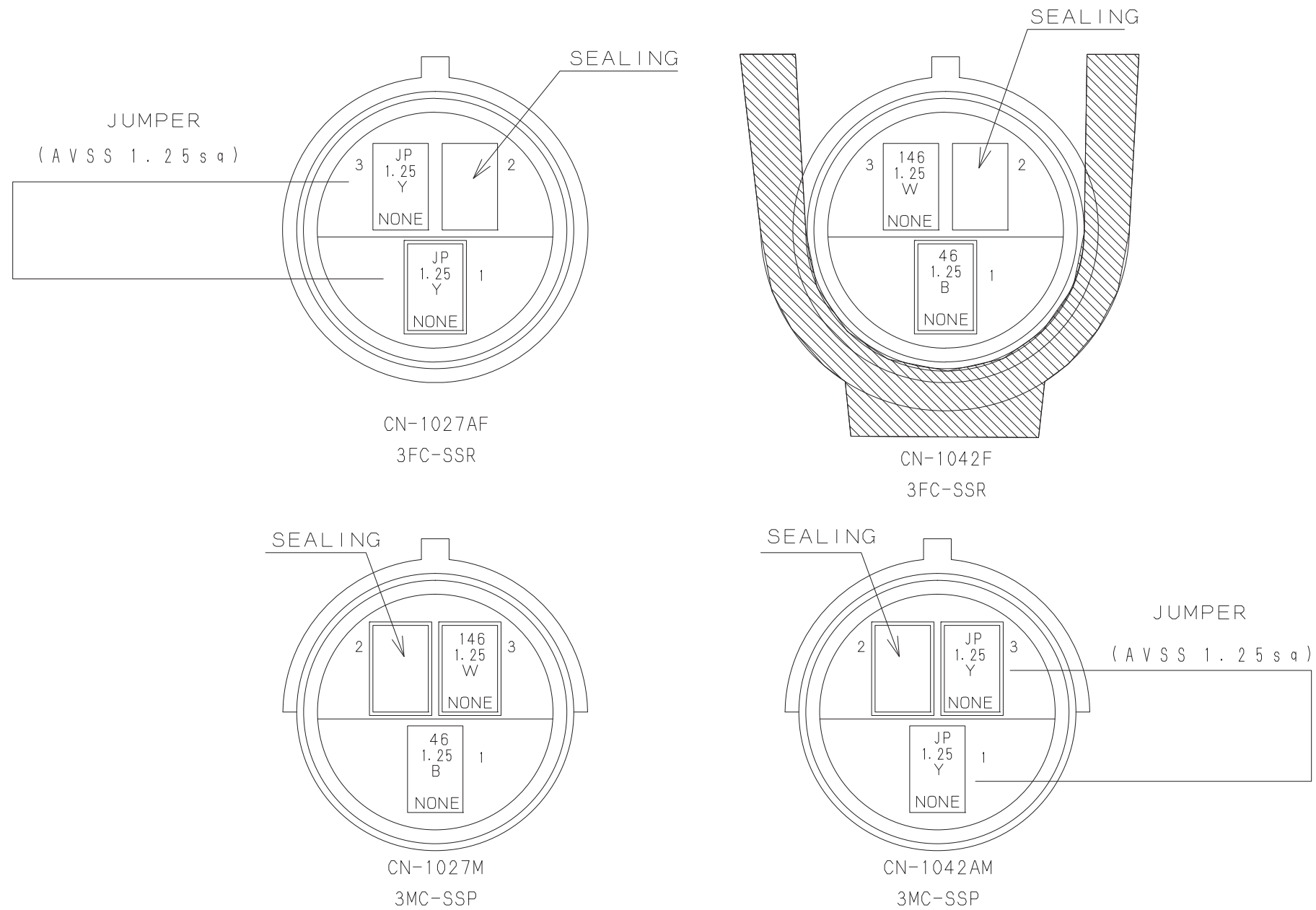

WIRE No. AND WIRE COLER LIST

No.	COLER	TYPE	SIZE	F R O M	DISTINGUISH SYMBOL	2-WIRE CLAMP No.	CONNECTION	2-WIRE CLAMP No.	DISTINGUISH SYMBOL	TO
46	B	VCTF	1.25	CN-1042F			—————			CN-1027M
146	W	VCTF	1.25	CN-1042F			—————			CN-1027M
JP	Y	AVSS	1.25	CN-1027AF			———┐			
JP	Y	AVSS	1.25				———┐			CN-1027AF
JP	Y	AVSS	1.25	CN-1042AM			———┐			
JP	Y	AVSS	1.25				———┐			CN-1042AM

CABLE

CONNECT TO ANGLE DETECTOR
(FIX JIB)

CN-1019M

5MAE-774R16+C-CL12



CONNECT TO JUNCTION BOX
(UPPER BOOM)

CN-1016F

5FAE-776P16+C-CL12

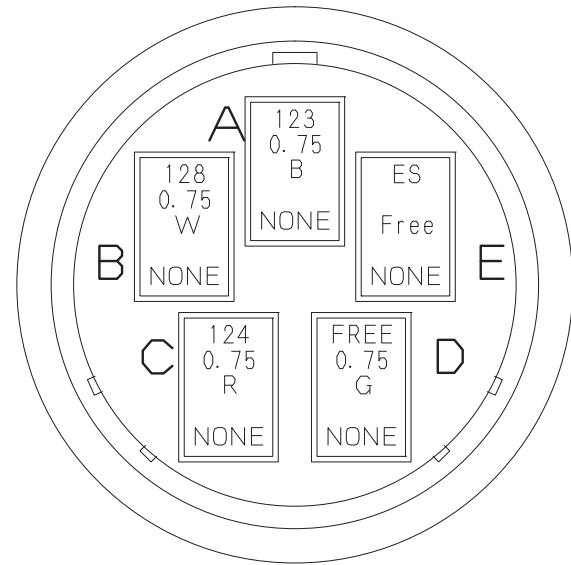

CN-1016F
5FAE-776P16+C-CL12

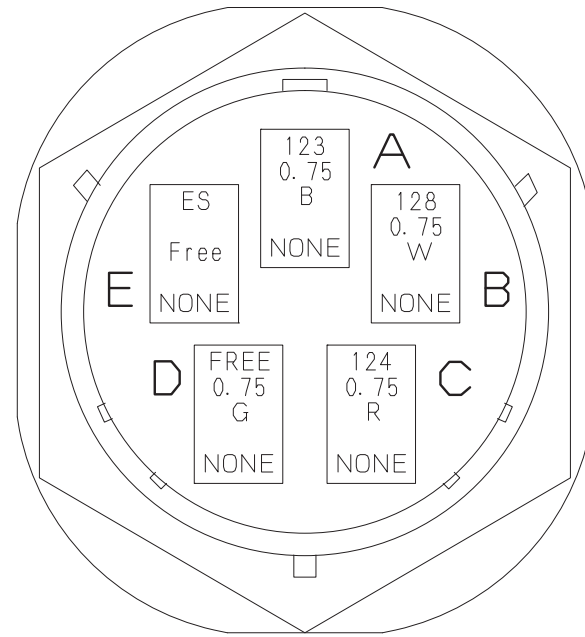

CN-1019M
5MAE-774R16+C-CL12

WIRE No. AND WIRE COLER LIST

WIRE No.	COLER	TYPE	SIZE	F R O M	PIN No.	2-WIRE CLAMP No.	CONNECTION	2-WIRE CLAMP No.	PIN No.	TO
123	B	2PNCT-SB	0.75	CN-1016F	1				1	CN-1019M
124	R	2PNCT-SB	0.75	CN-1016F	3				3	CN-1019M
128	W	2PNCT-SB	0.75	CN-1016F	2				2	CN-1019M
FREE	G	2PNCT-SB	0.75	CN-1016F	4				4	CN-1019M
ES	Free	SHIELD		CN-1016F	5					(CN-1019M)
ES	Free	SHIELD		(CN-1016F)					5	CN-1019M

19. ELECTRICAL PART OF CAMERA CONTROLLER

SOL : SOLENOID VALVE
 SW : SWITCH
 PSW : PRESSURE SWITCH
 ATT. : ATTACHMENT
 C/W : COUNTER WEIGHT
 CB/W : CARBODY WEIGHT

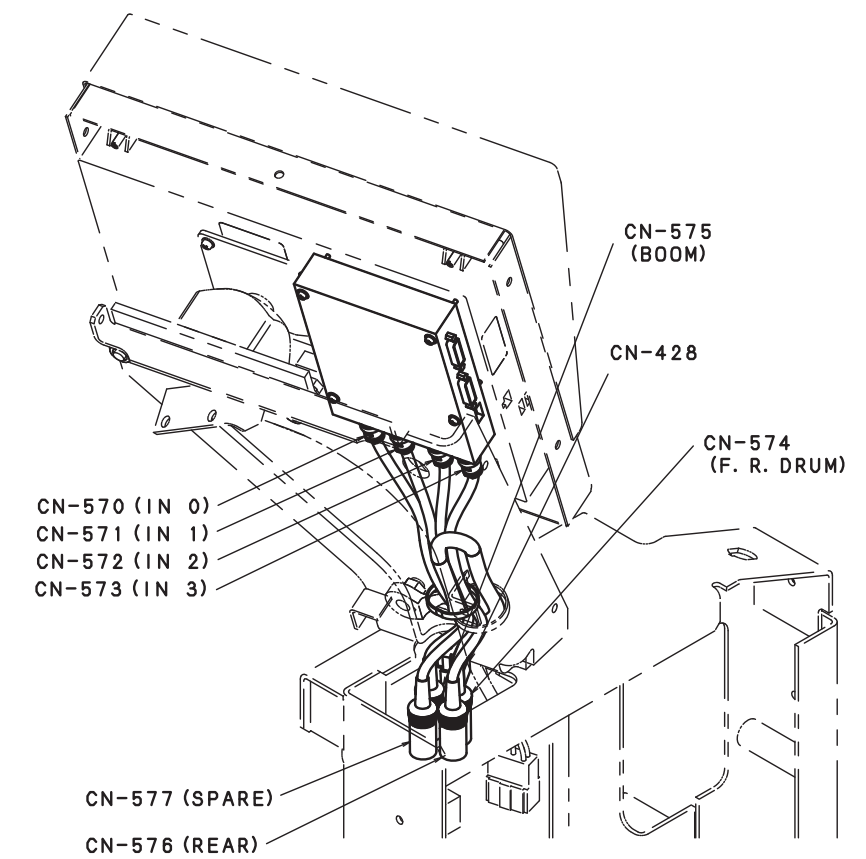
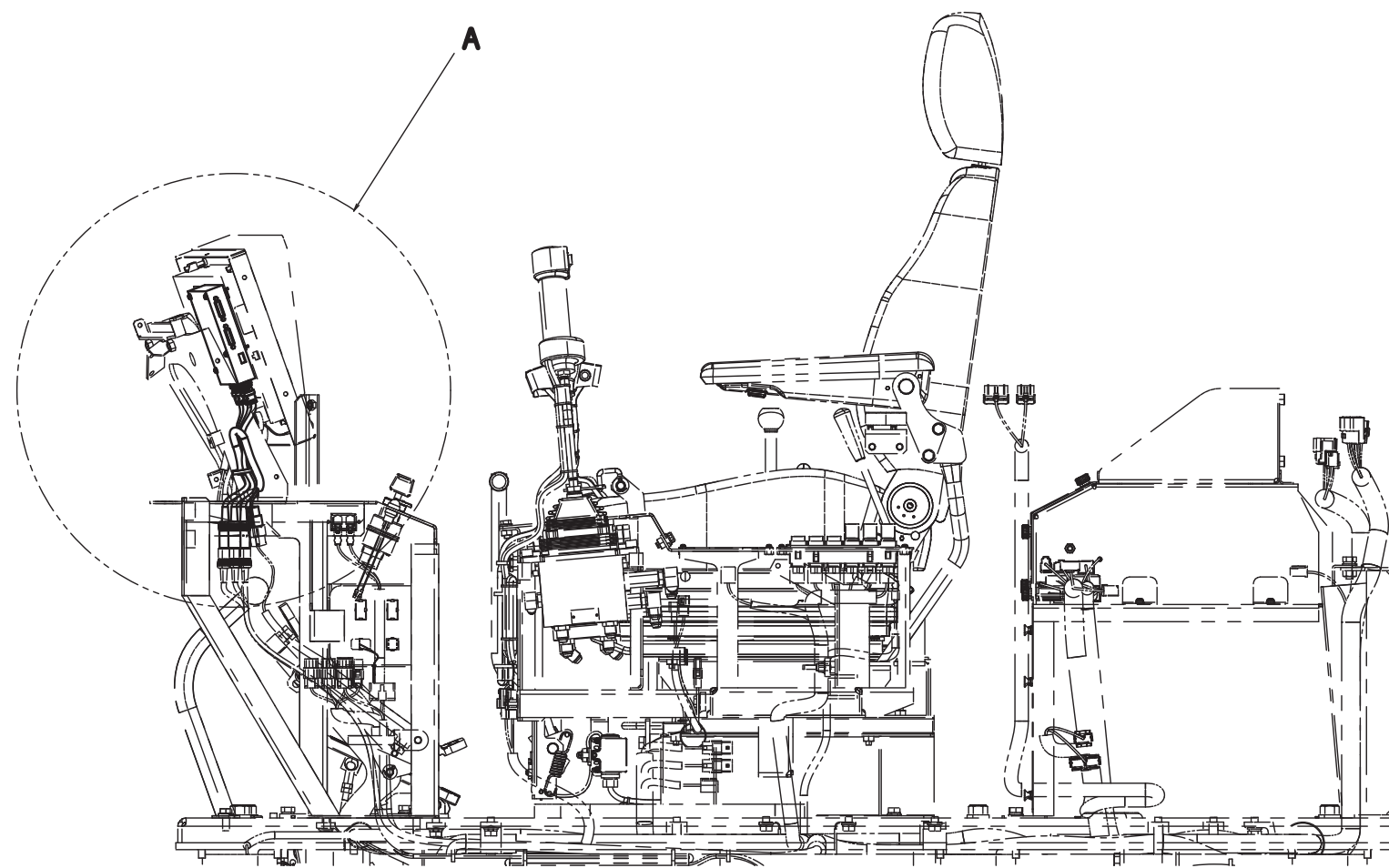

10. ELECTRIC SYSTEM

SOL : SOLENOID VALVE
 SW : SWITCH
 PSW : PRESSURE SWITCH
 ATT. : ATTACHMENT
 C/W : COUNTER WEIGHT
 CB/W : CARBODY WEIGHT

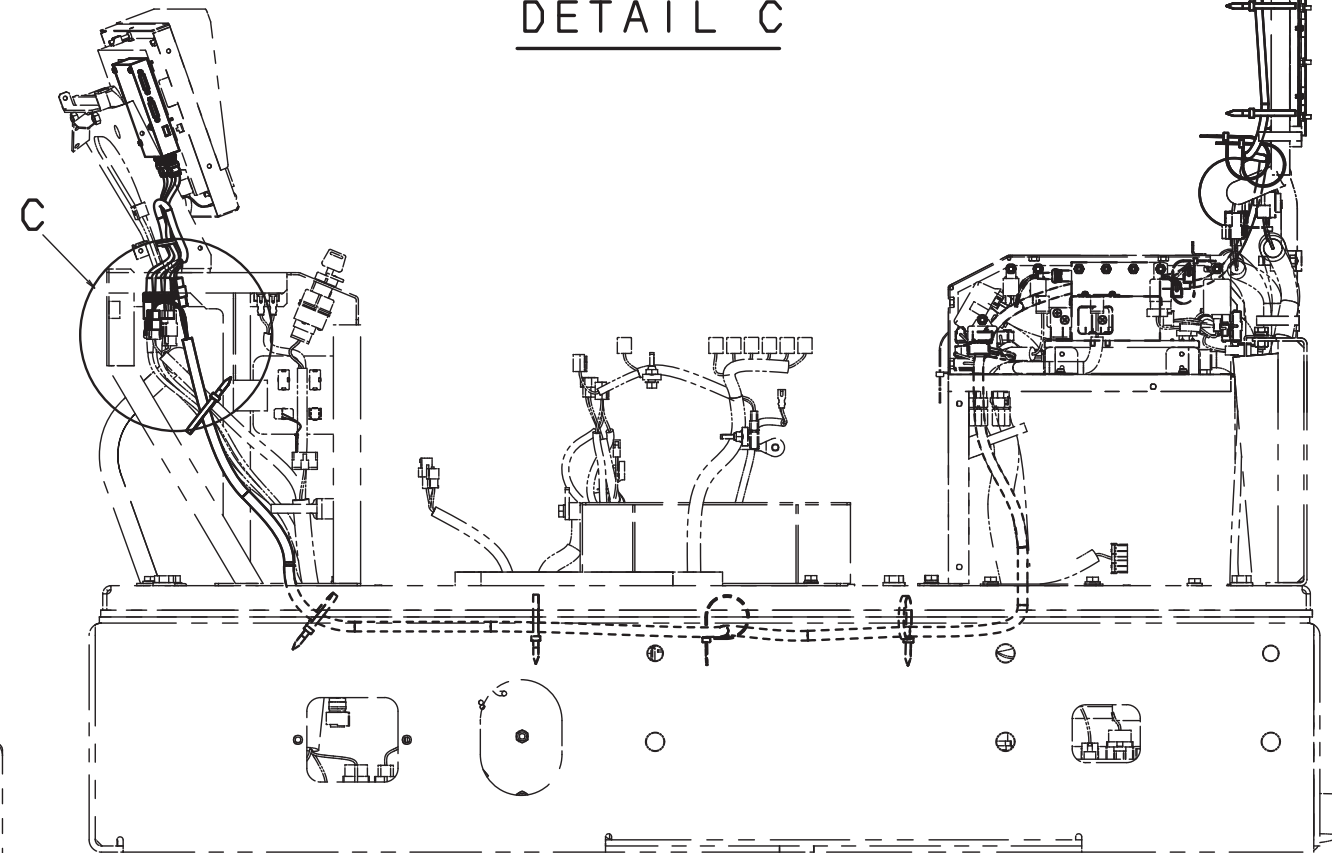
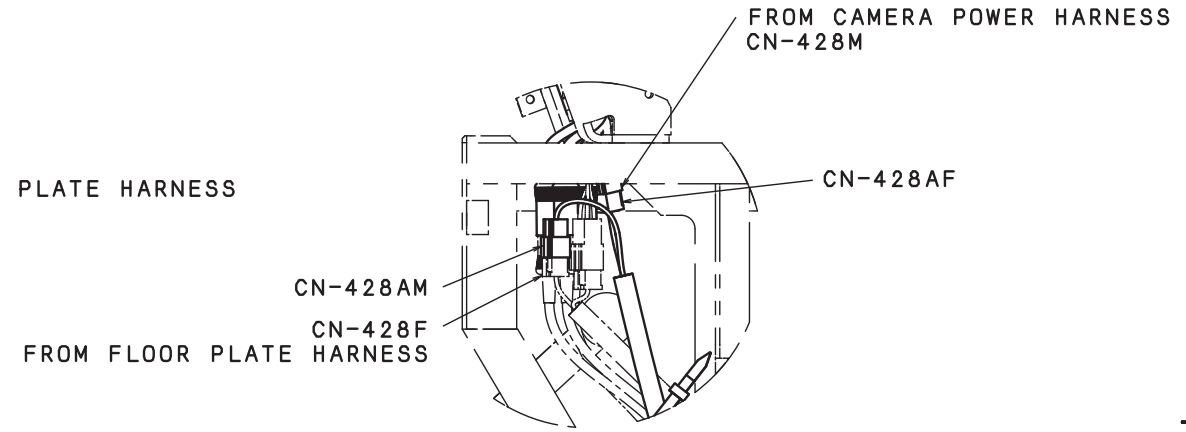
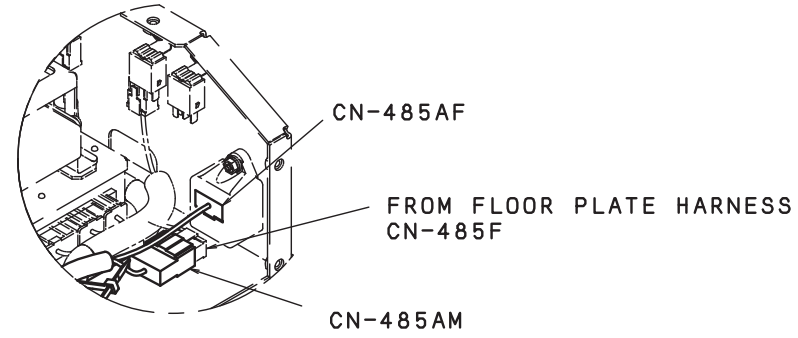
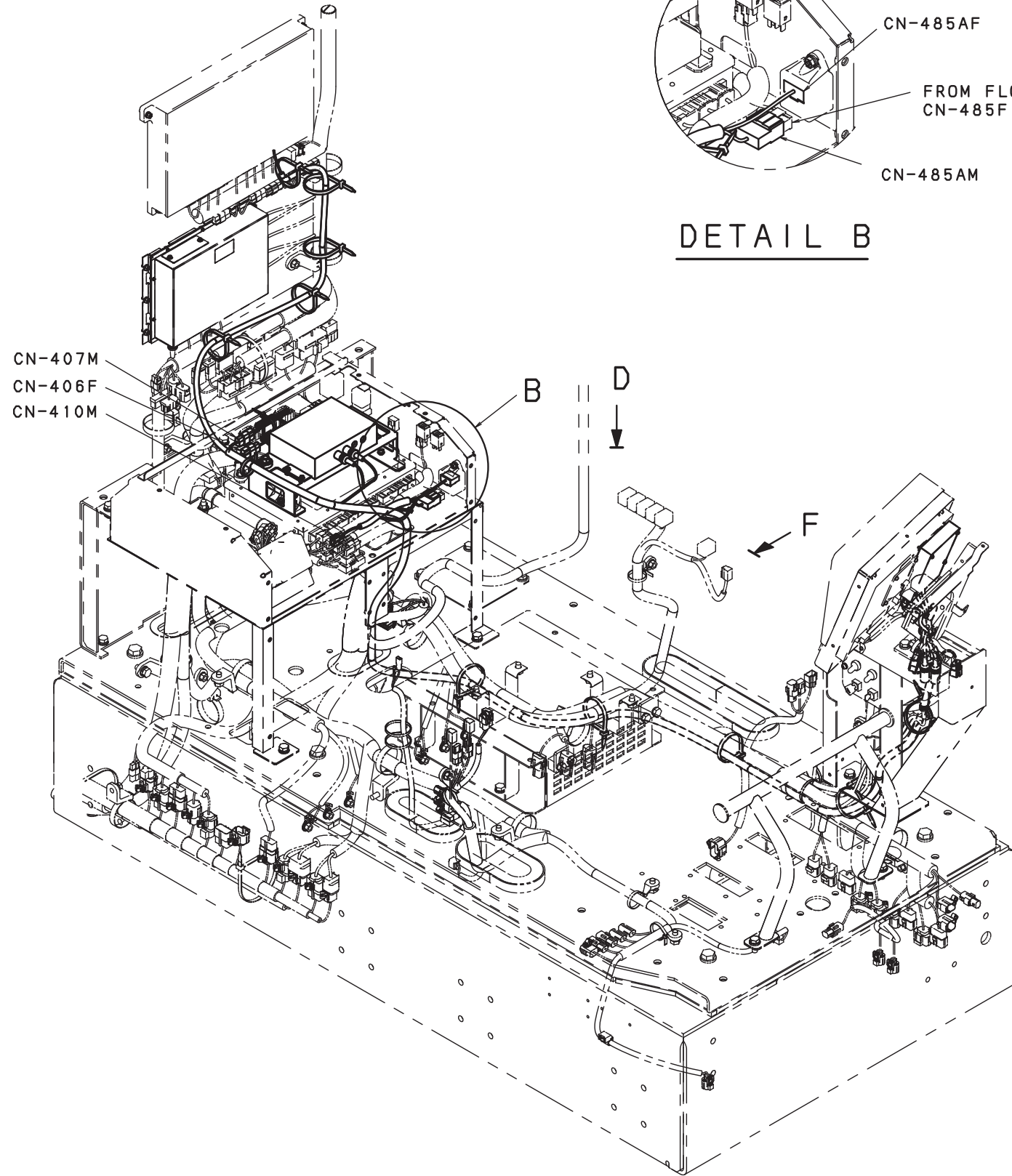

SOL : SOLENOID VALVE
 SW : SWITCH
 PSW : PRESSURE SWITCH
 ATT. : ATTACHMENT
 C/W : COUNTER WEIGHT
 CB/W : CARBODY WEIGHT

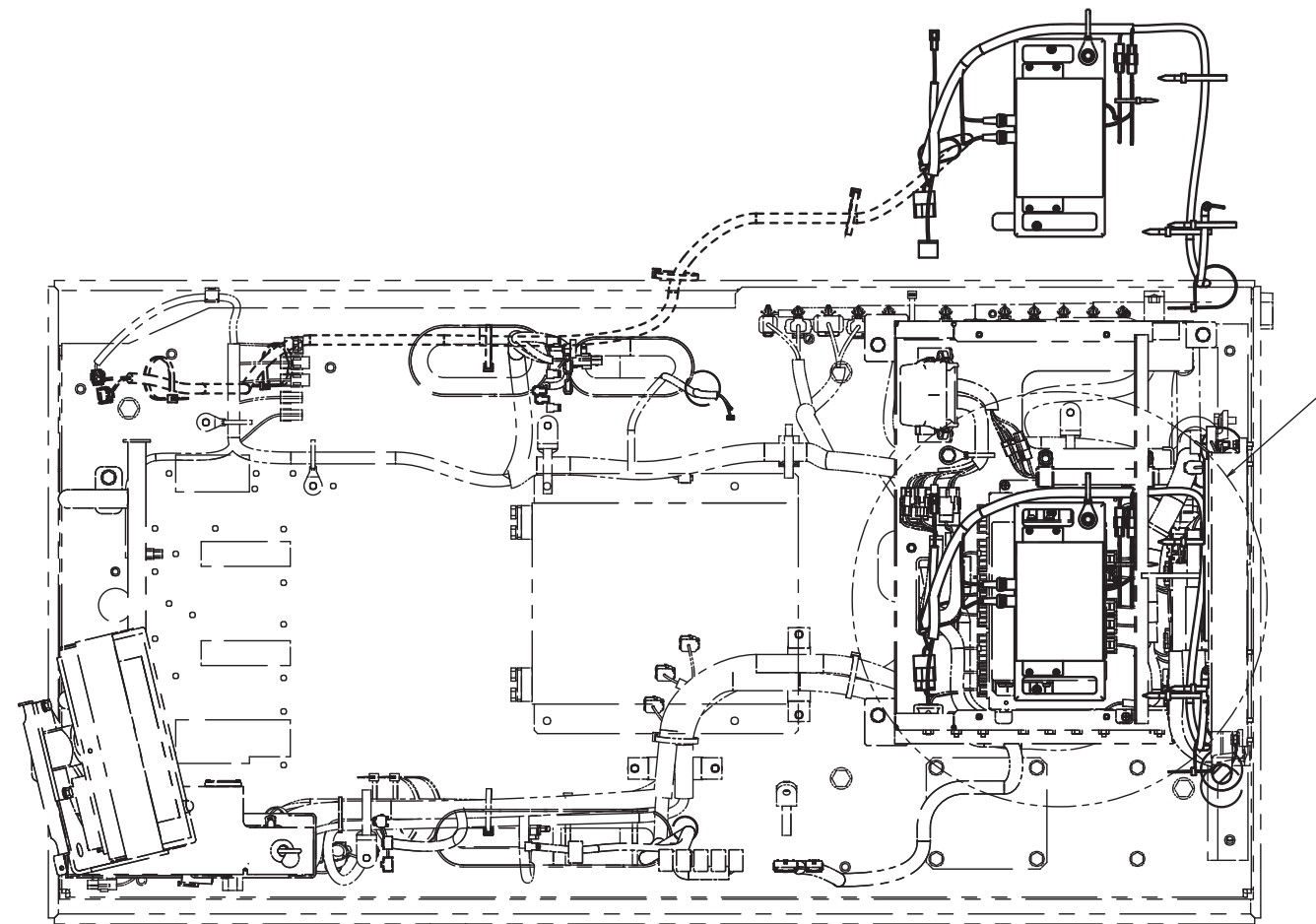

VIEW D

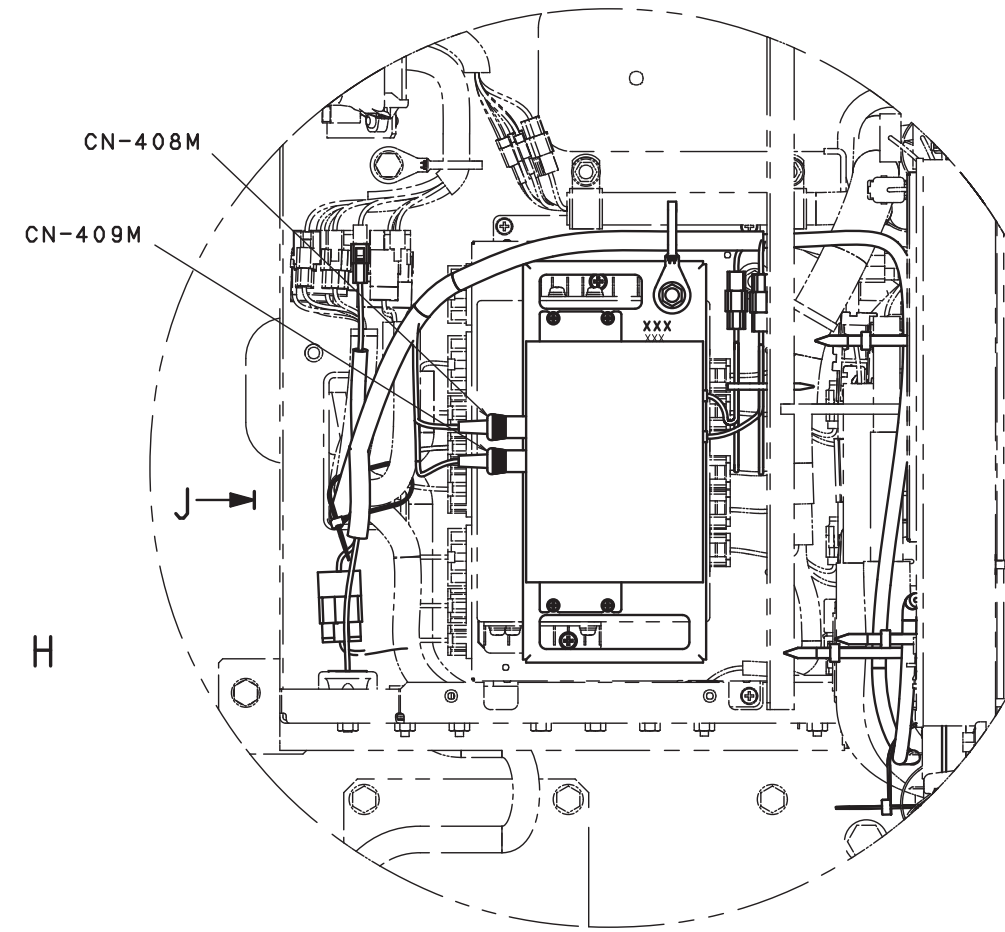

DETAIL H

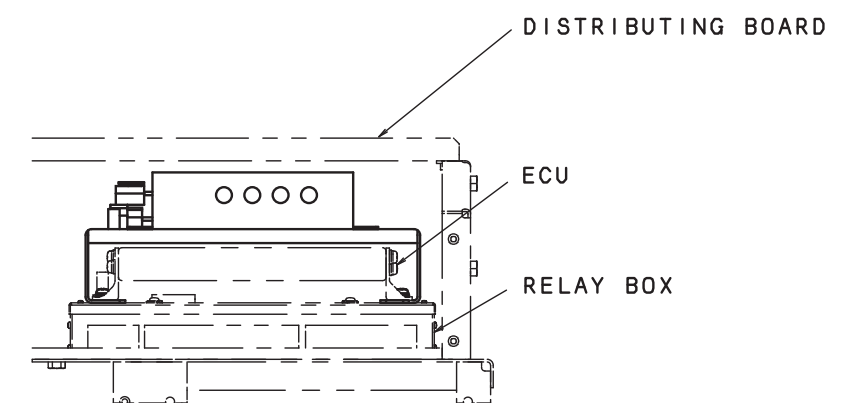

VIEW J

10. ELECTRIC SYSTEM

CAMERA CONTROLLER HARNESS

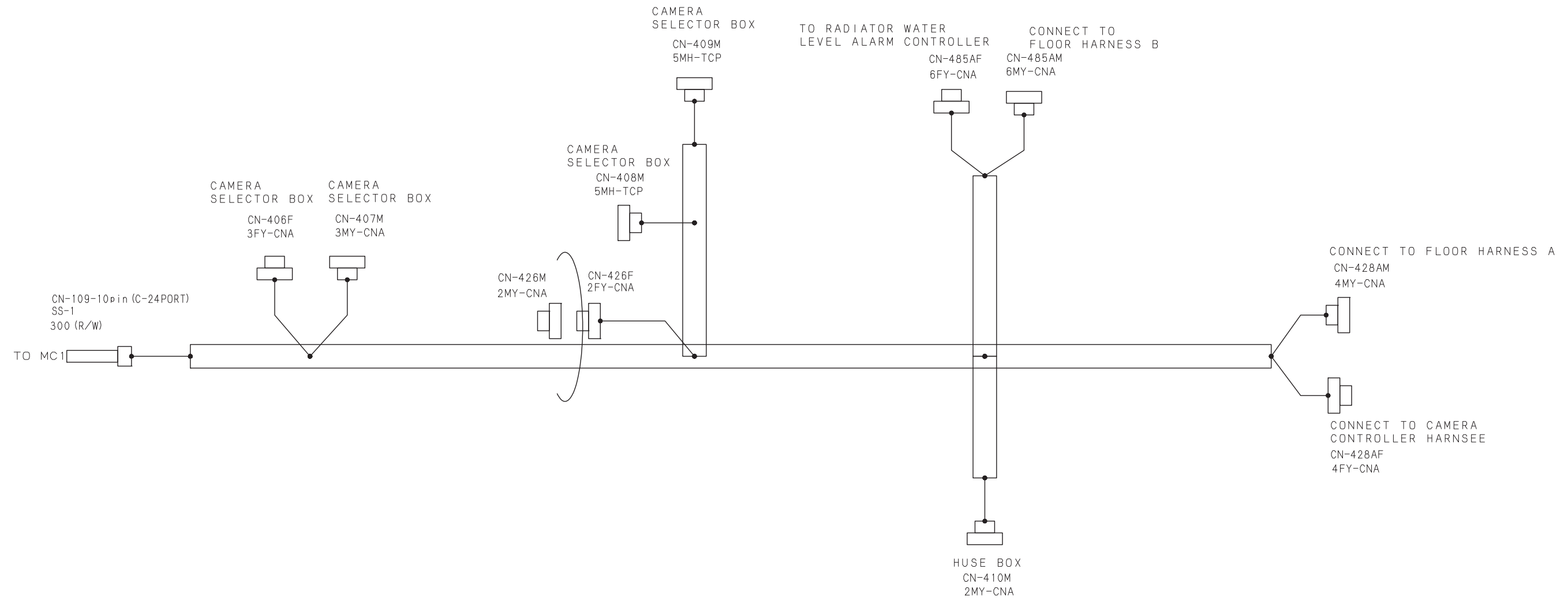

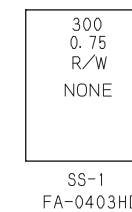
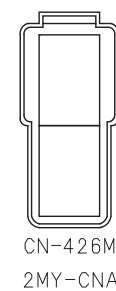
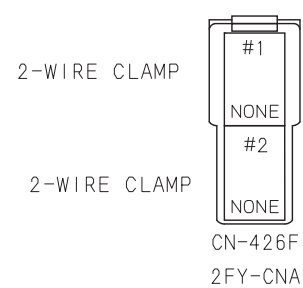
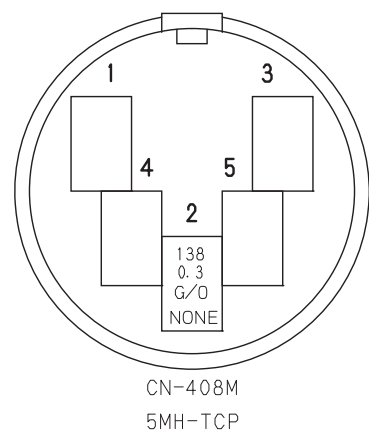
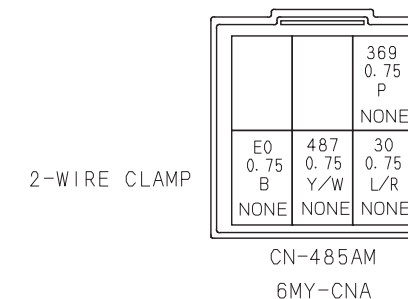
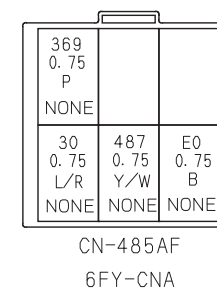
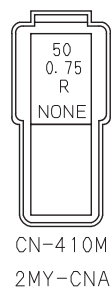
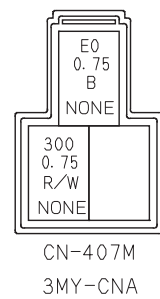
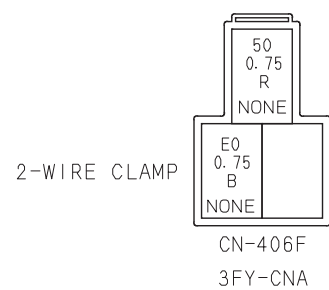

#1 138 0.3 G/O +138 0.75 G/O
#2 140 0.3 Y +140 0.75 Y

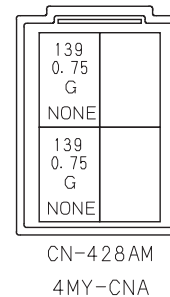
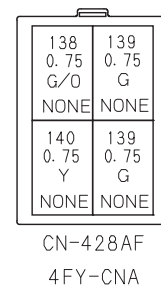
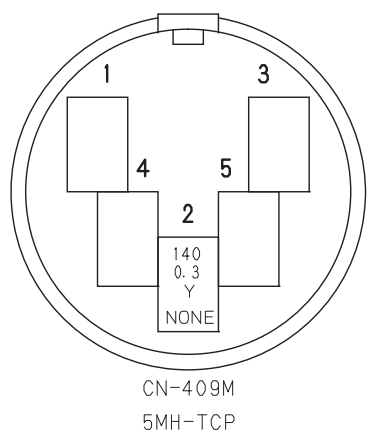

WIRE No. AND WIRE COLOR LIST

WIRE No.	COLOR	TYPE	SIZE	F	R	O	M	2-WIRE CLAMP No.	CONNECTION	2-WIRE CLAMP No.	T
30	L/R	AVSS	0.75					CN-485AF			CN-485AM
50	R	AVSS	0.75					CN-406F			CN-410M
138	G/O	AVSS	0.3					CN-408M			CN-426F
138	G/O	AVSS	0.75					CN-428AF			CN-426F
139	G	AVSS	0.75					CN-428AF			CN-428AM
139	G	AVSS	0.75					CN-428AF			CN-428AM
140	Y	AVSS	0.3					CN-409M			CN-426F
140	Y	AVSS	0.75					CN-428AF			CN-426F
300	R/W	AVSS	0.75					SS-1			CN-407M
369	P	AVSS	0.75					CN-485AF			CN-485AM
487	Y/W	AVSS	0.75					CN-485AF			CN-485AM
E0	B	AVSS	0.75					CN-485AF			CN-485AM
E0	B	AVSS	0.75					CN-406F			CN-485AM
E0	B	AVSS	0.75					CN-406F			CN-407M

10. ELECTRIC SYSTEM

CAMERA CONTROLLER HARNESS

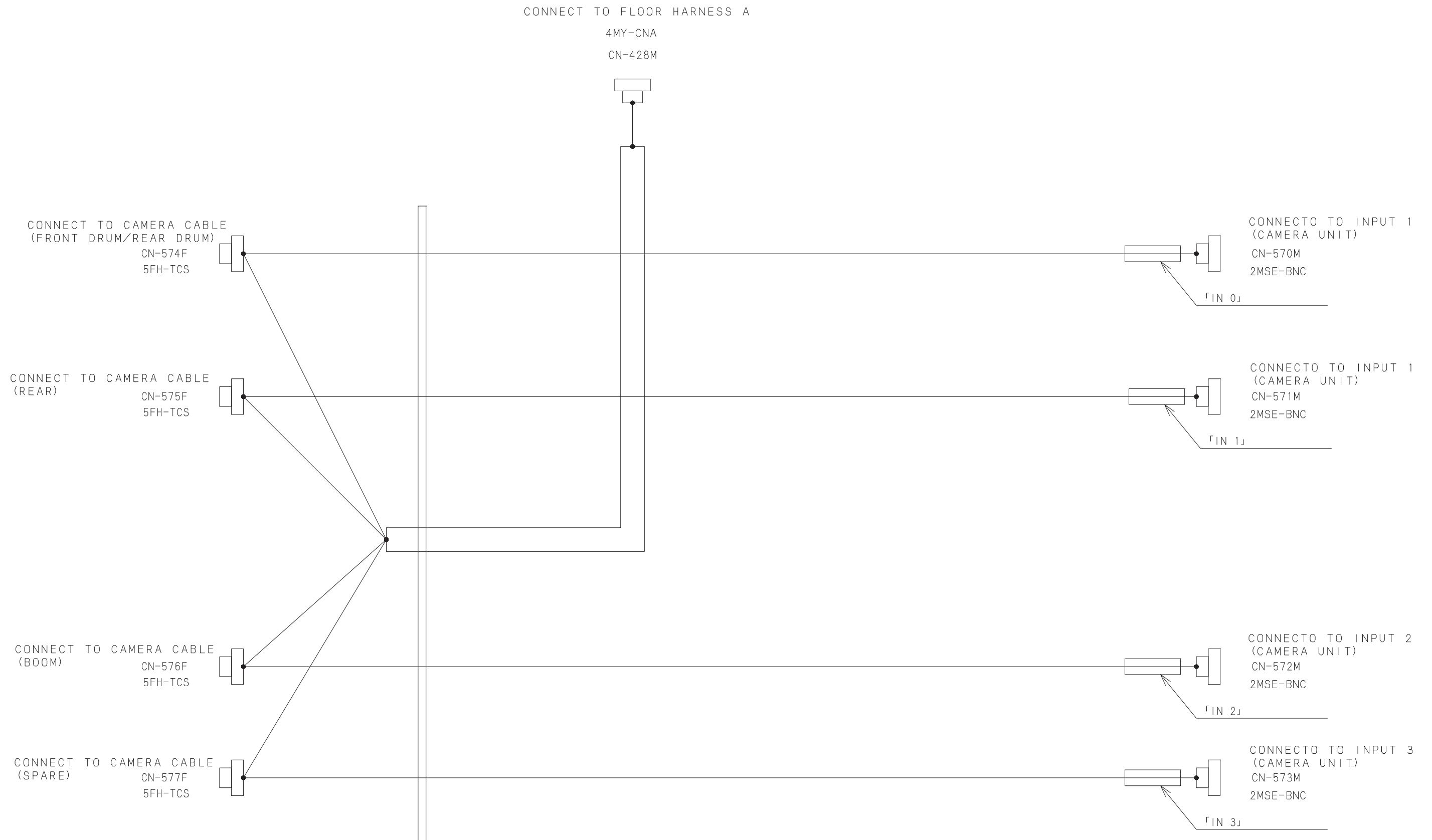

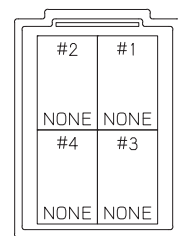

CN-428M
4MY-CNA

- #1 140C 0.3 Y + 140E 0.3 Y
- #2 139E 0.3 G + 139F 0.3 G
- #3 140F 0.3 Y + 140G 0.3 Y
- #4 139G 0.3 G + 139H 0.3 G

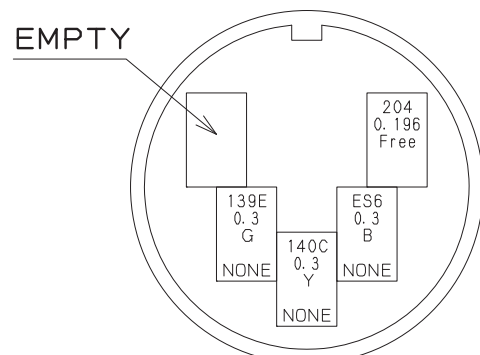

CN-574F
5FH-TCS

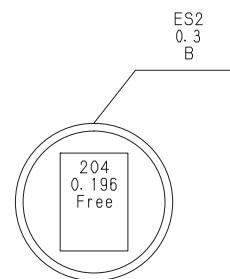

CN-570M
2MSE-BNC

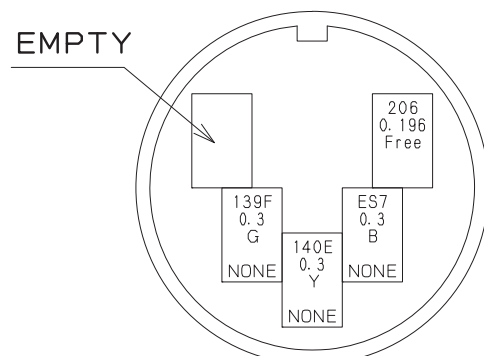

CN-575F
5FH-TCS

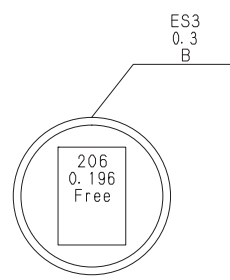

CN-571M
2MSE-BNC

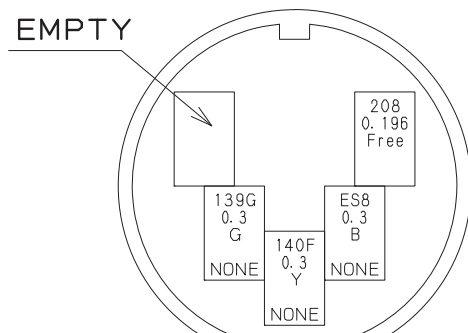

CN-576F
5FH-TCS

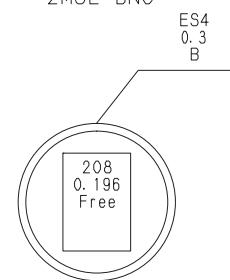

CN-572M
2MSE-BNC

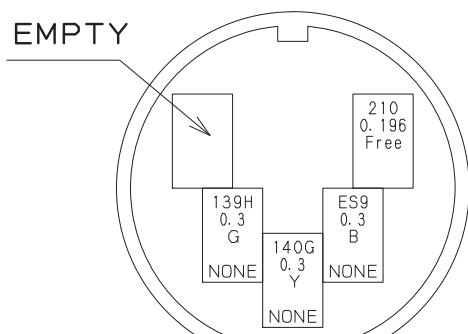

CN-577F
5FH-TCS

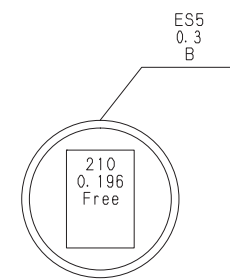

CN-573M
2MSE-BNC

WIRE No. AND WIRE COLER LIST

WIRE No.	COLER	TYPE	SIZE	F	R	O	M	PIN No.	DISTINGUISH SYMBOL	2-WIRE CLAMP No.	CONNECTION	2-WIRE CLAMP No.	DISTINGUISH SYMBOL	PIN No.	TO	LENGTH (mm)
139E	G	AVSS	0.3	CN-428M				2		DS-B92				5	CN-574F	300
139F	G	AVSS	0.3	CN-428M				2		DS-B92				5	CN-575F	300
139G	G	AVSS	0.3	CN-428M				4		DS-B94				5	CN-576F	300
139H	G	AVSS	0.3	CN-428M				4		DS-B94				5	CN-577F	300
140C	Y	AVSS	0.3	CN-428M				1		DS-B90				2	CN-574F	300
140E	Y	AVSS	0.3	CN-428M				1		DS-B90				2	CN-575F	300
140F	Y	AVSS	0.3	CN-428M				3		DS-B93				2	CN-576F	300
140G	Y	AVSS	0.3	CN-428M				3		DS-B93				2	CN-577F	300
204	Free	3C-2W	0.196	CN-574F				1						1	CN-570M	200
ES2	B	AVSS	0.3	(CN-574F)										2	CN-570M	100
ES6	B	AVSS	0.3	CN-574F				4							(CN-570M)	100
206	Free	3C-2W	0.196	CN-575F				1						1	CN-571M	200
ES3	B	AVSS	0.3	(CN-575F)										2	CN-571M	100
ES7	B	AVSS	0.3	CN-575F				4							(CN-571M)	100
208	Free	3C-2W	0.196	CN-576F				1						1	CN-572M	200
ES4	B	AVSS	0.3	(CN-576F)										2	CN-572M	100
ES8	B	AVSS	0.3	CN-576F				4							(CN-572M)	100
210	Free	3C-2W	0.196	CN-577F				1						1	CN-573M	200
ES5	B	AVSS	0.3	(CN-577F)										2	CN-573M	100
ES9	B	AVSS	0.3	CN-577F				4							(CN-573M)	100

10. ELECTRIC SYSTEM

20. ELECTRICAL PART OF IT CONTROLLER INSTALLATION

SOL : SOLENOID VALVE
 SW : SWITCH
 PSW : PRESSURE SWITCH
 ATT. : ATTACHMENT
 C/W : COUNTER WEIGHT
 CBW : CARBODY WEIGHT

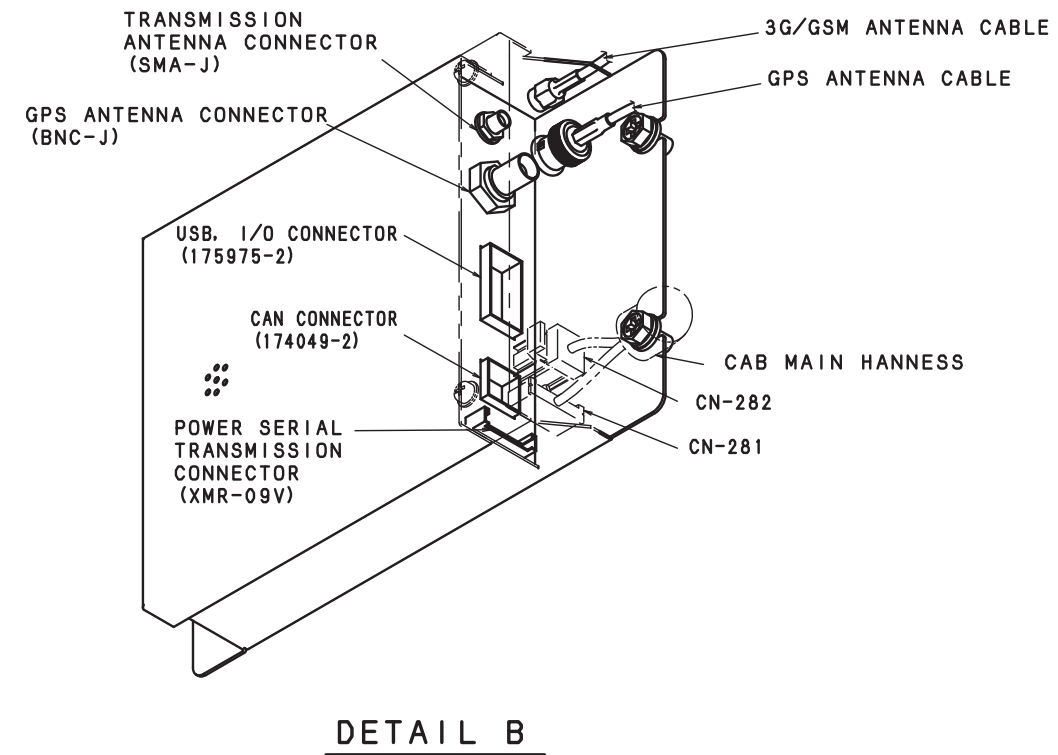
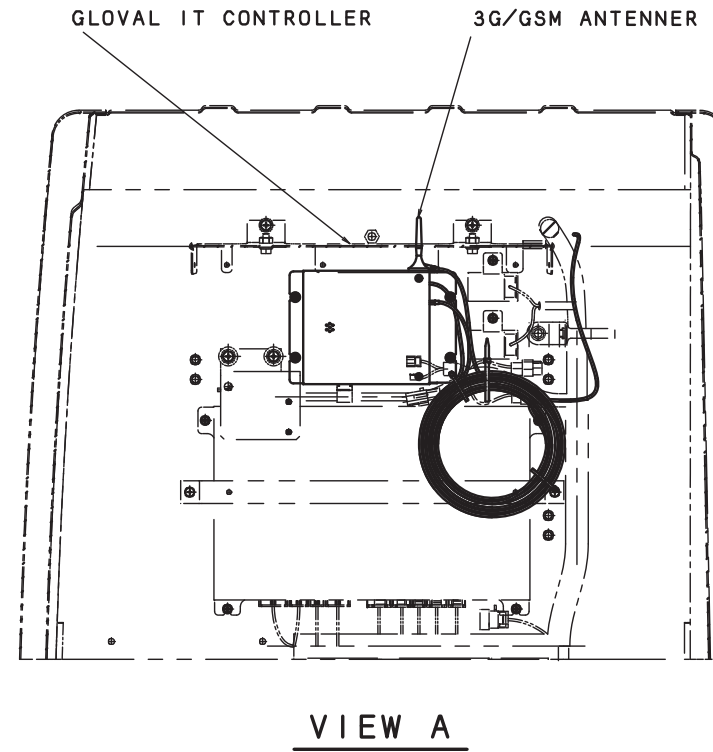
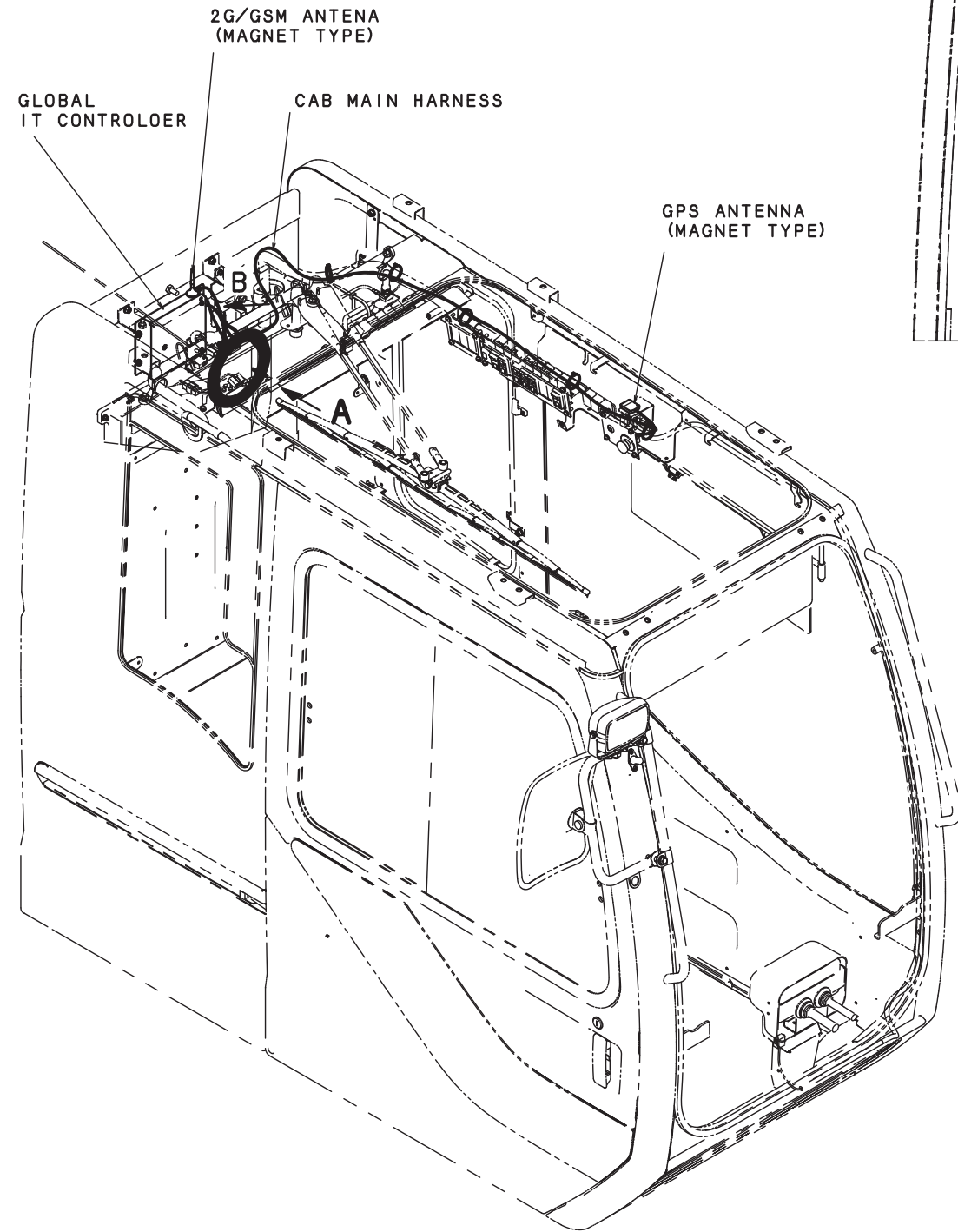

10.1.3 LOCATION AND USE OF FUSE

Fuse box and use

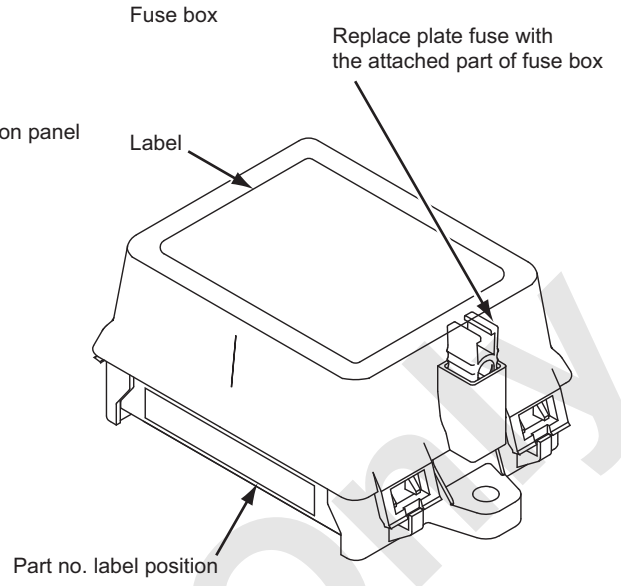
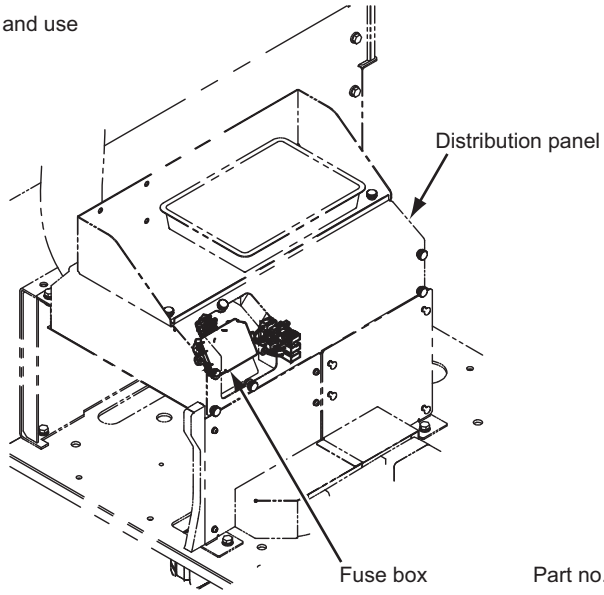

Reference

10. ELECTRIC SYSTEM

Classification of Fuse Use					
Fuse No.	Capacity	Type	Line No.	Use	Location
F1	20A	Automotive Blade	1A - 11	Main power	Fuse box
F2	5A		4 - 12	AIS air-con battery voltage	
F3	5A		1B - 13	ITC	
F4	5A		1B - 14	ML, MC1.MC2 radio backup	
F5	10A		2F - 15	Bypass switch	
F6	5A		2F - 16	Release switch	
F7	10A		2F - 17	For ML control	
F8	10A		2F - 18	For ML output	
F9	10A		2F - 19	For MC1 control	
F10	20A		2F - 20	For MC1 output	
F11	10A		2F - 21	Auto stop	
F12	10A		2F - 22	Engine condition	
F13	5A		52 - 23	One way radio	
F14	20A		2G - 24	Wiper	
F15	10A		2G - 25	Function lock	
F16	10A		2G - 26	Remote control	
F17	5A		2G - 27	Monitor	
F18	15A		2E - 28	Air-con	
F19	10A		2E - 29	Air-con 2	
F20	10A		2E - 30	Fan motor	

Classification of Fuse Use					
Fuse No.	Capacity	Type	Line No.	Use	Location
F21	5A	Automotive Blade	51 - 31	Generating detect	Fuse box
F22	10A		471 - 32	PCV1	
F23	10A		471 - 33	PCV2	
F24	15A		2J - 34	ECU (+BF)	
F25	20A		2J - 35	ECU (J08E : + B)	
F26	15A		2J - 36	ECU (P11C : + B)	
F27	20A		2I - 37	Dc motor for oil cooler ①	
F28	20A		2I - 38	Dc motor for oil cooler ②	
F29	10A		2I - 39	Swing flasher / Voice alarm	
F30	5A		54 - 40	Starter	
F31	10A		2H - 41	For MC control	
F32	20A		2H - 42	For MC2 output	
F33	5A		2H - 43	For MC2 ground output	
F34	5A		2H - 44	Over hoist LS	
F35	10A		2H - 45	Fuel pump / lighter	
F36	10A		2K - 46	For MC1 ground output 1	
F37	10A		2K - 47	For MC1 ground output 2	
F38	5A		2K - 48	Neutral free	
F39	10A		2K - 49	Light	
F40	10A		2K - 50	Spare	

! DANGER

Ensure to turn starter switch OFF when replacing fuse.

Replace the fuse with the same capacity.

If fuse blows off right after replaced, there is some abnormality in the electric circuit.

Find out a cause and take necessary action.

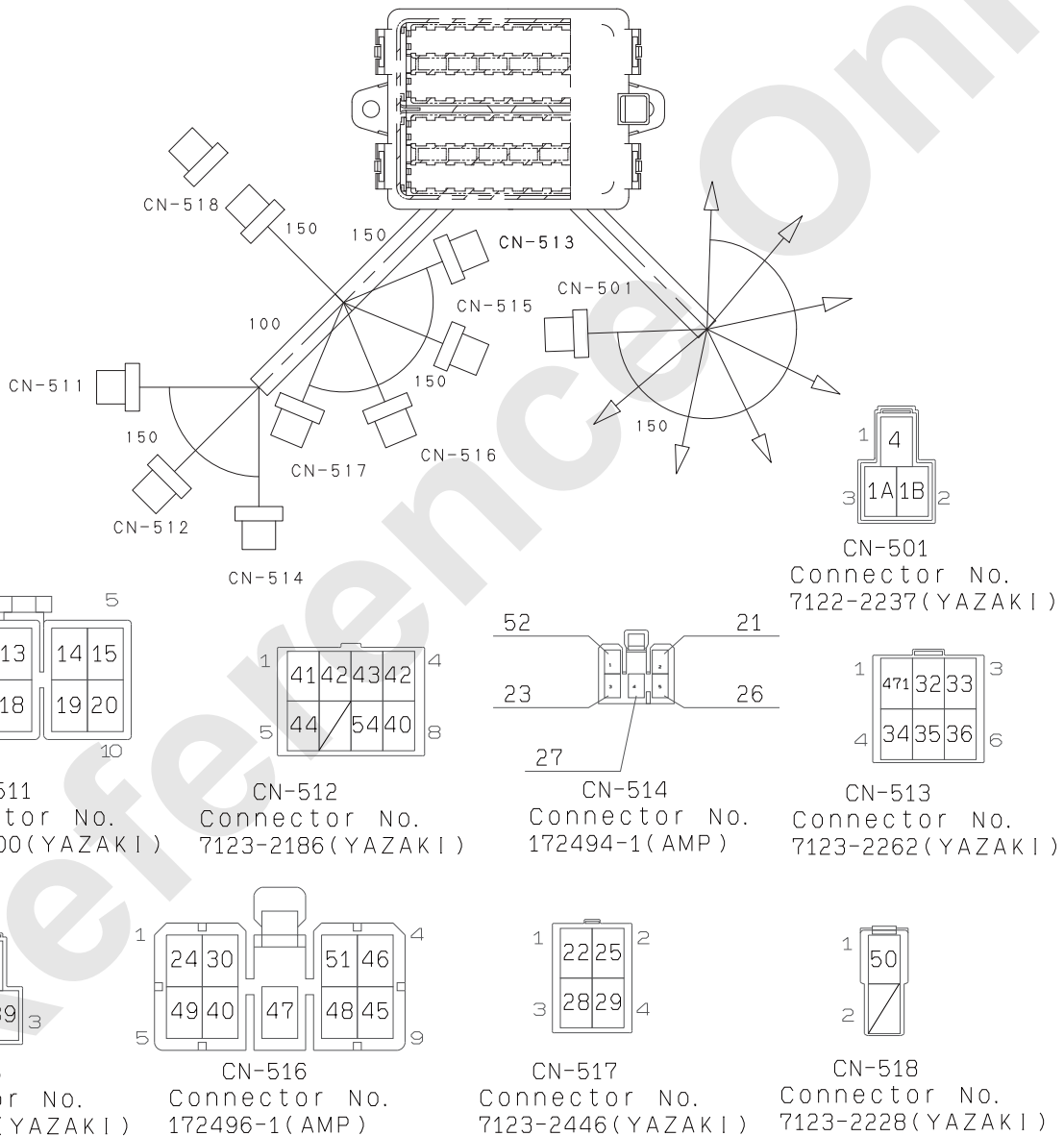

Fuse Connection Schematic

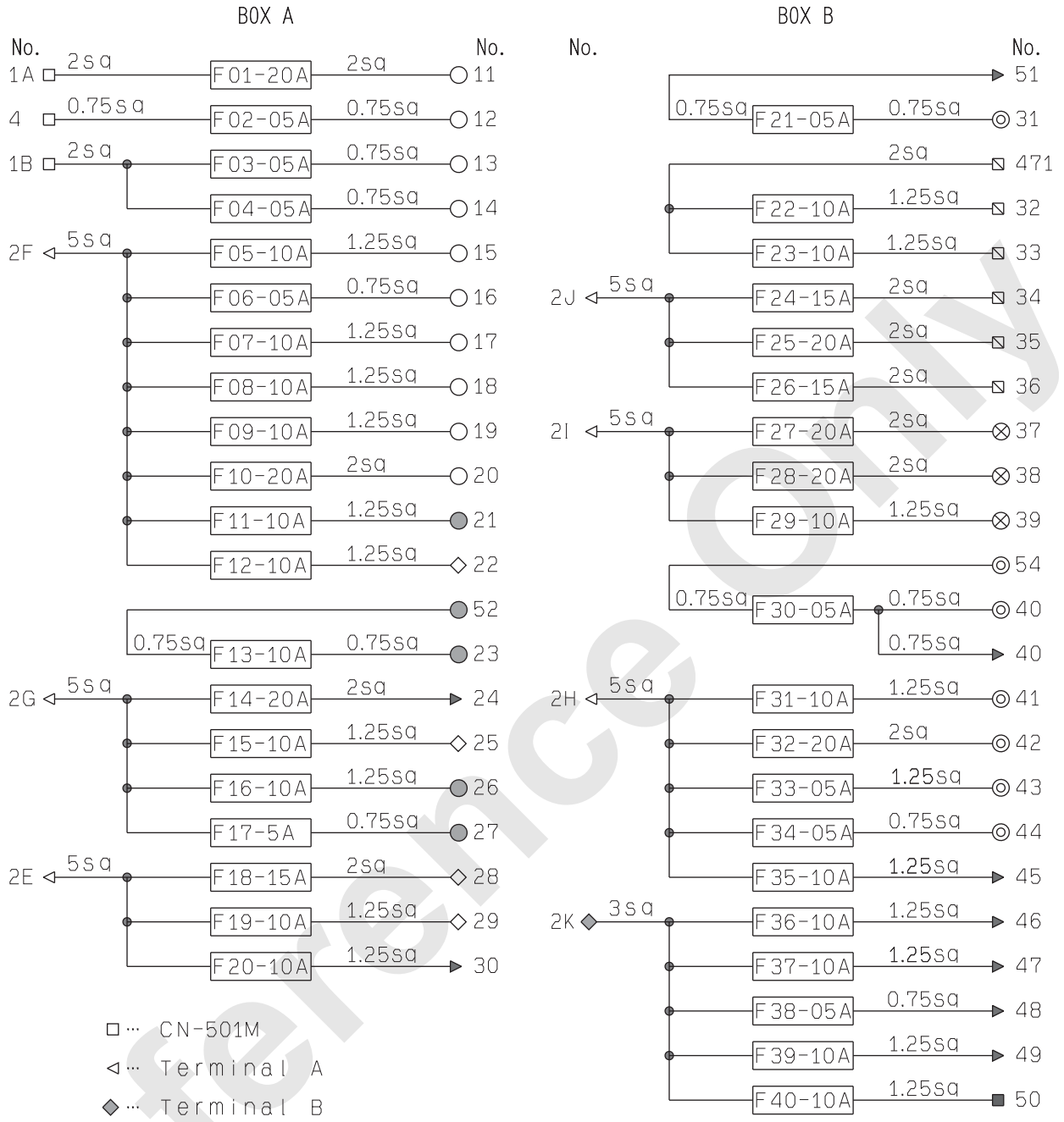

10. ELECTRIC SYSTEM

Label

F	A		F	A	F	A		F	A
1	20	20A	11	10	21	5	10A	31	10
2	5		X	12	10	22		10	X
3	5	2		13	5	23	10	5	
4	5		15A	14	20	24	15		5A
5	10	X		15	10	25	20	X	
6	5		2	16	10	26	15		4
7	10	(Spare)		17	5	27	20	(Spare)	
8	10		20	18	15	28	20		10
9	10	10		19	10	29	10	5	
10	20			20	10	30	5		

10.1.4 WIPER CONTROL RELAY

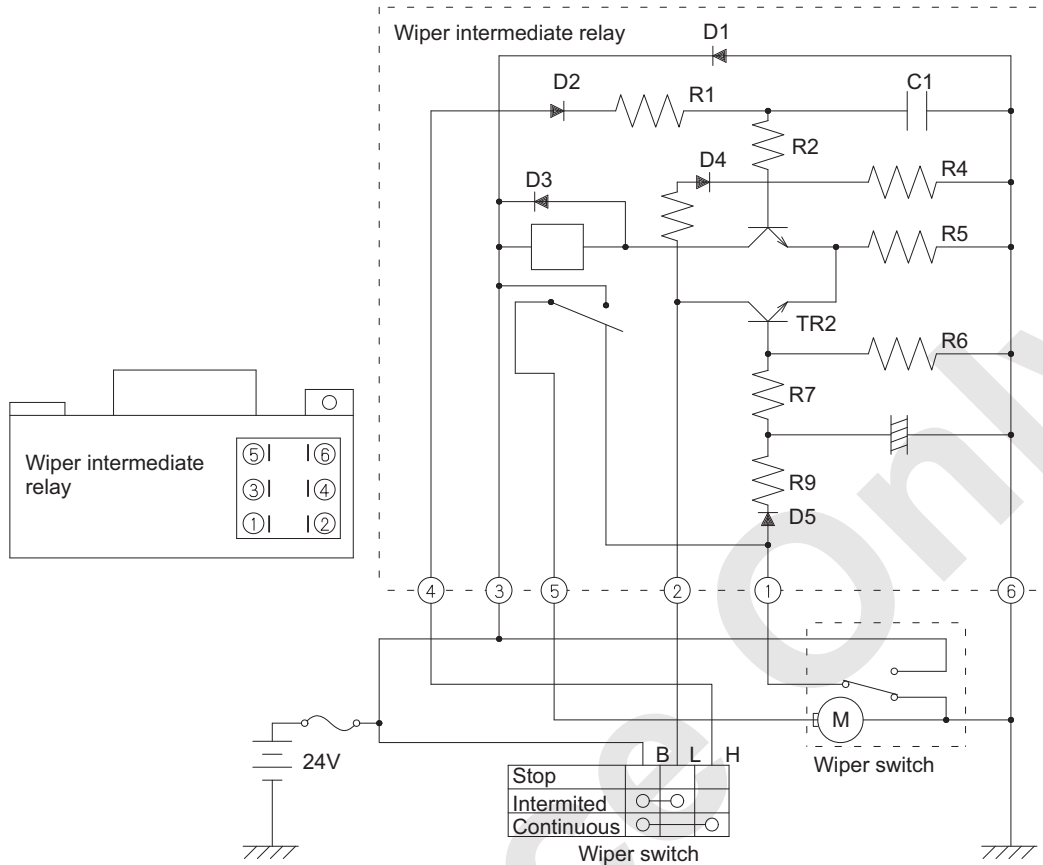

10. ELECTRIC SYSTEM

10.1.5 PRESSURE SWITCH (FOR PROPEL MOTION DETECT)

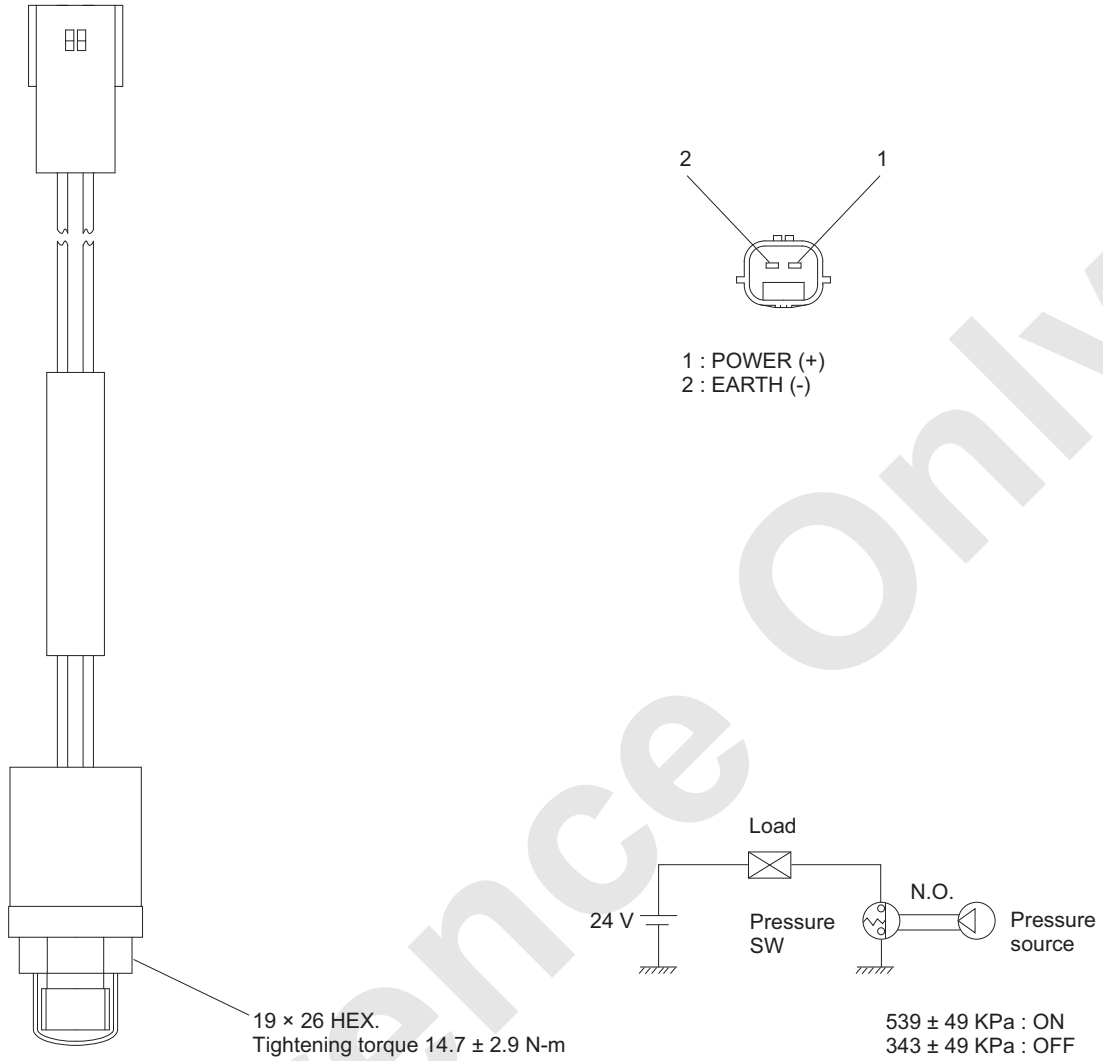

Use	[ON] Pressure (KPa)	[OFF] Pressure (KPa)
Propel motion detect pressure	539 ± 49	343 ± 49

10.1.6 PRESSURE SWITCH (FOOT BRAKE)

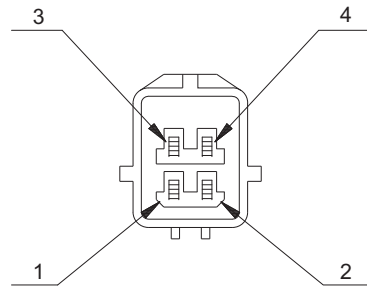

- 1 — W — COMMON
- 2 — R — POWER(+)
- 3 — — — NC
- 4 — G — OPEN COLLECTOR(+)

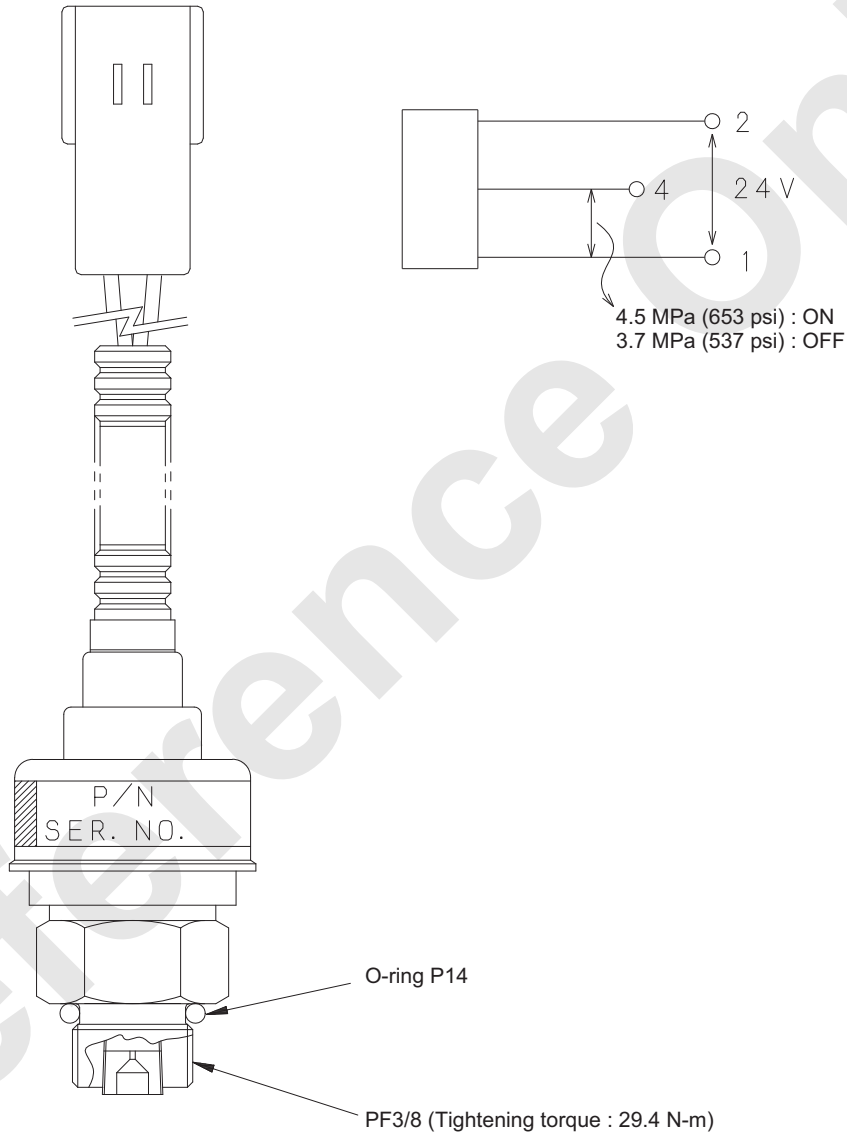

Use	[ON] Pressure (MPa)	[OFF] Pressure (MPa)
Propel motion detect pressure	4.5	3.7

10. ELECTRIC SYSTEM

10.1.7 PRESSURE SENSOR

(LS52S00015P1 • LC52S00019P1)

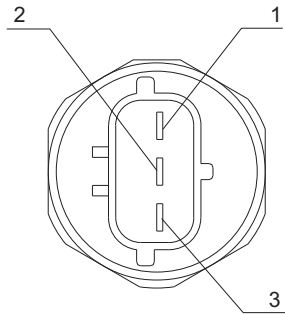

Location of connector terminal No.

- 1. COMMON
- 2. OUT - PUT (+)
- 3. POWER (+)

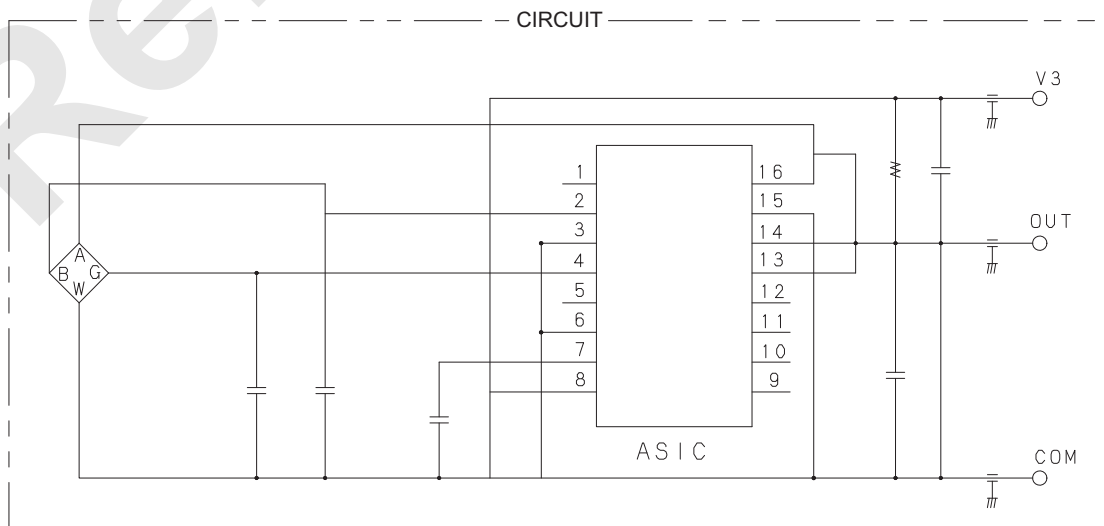
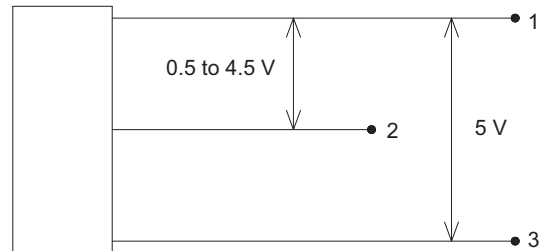
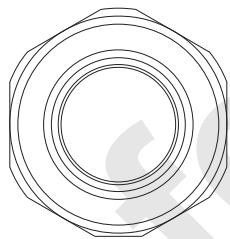
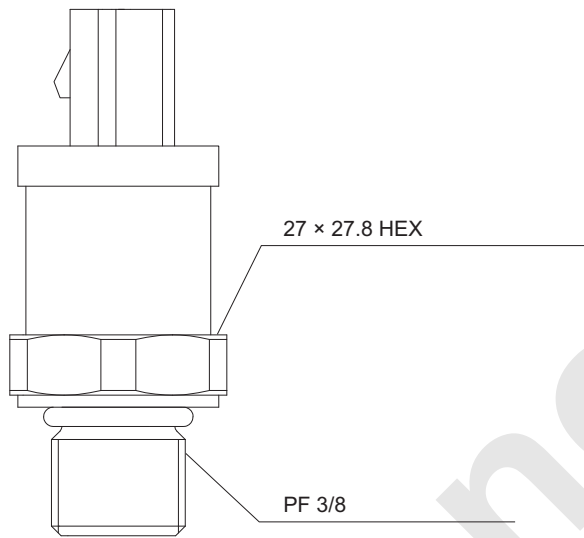

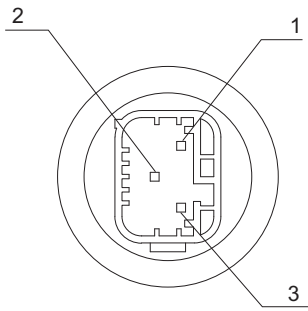

Location of connector terminal No.

- 1. COMMON
- 2. OUT - PUT (+)
- 3. POWER (+)

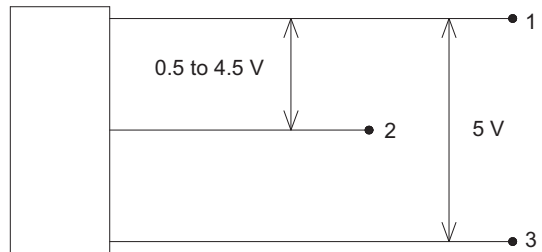
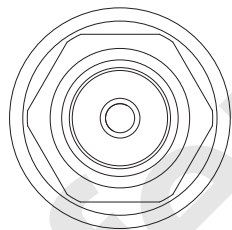
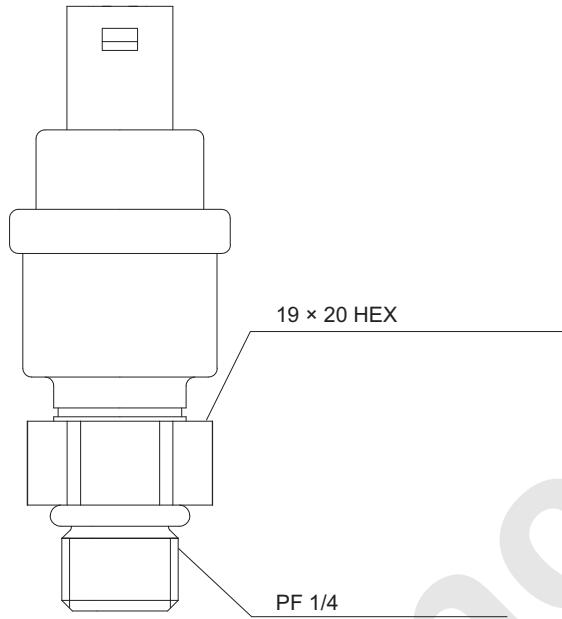

Reference Only

10. ELECTRIC SYSTEM

Use	Part number	Pressure range MPa (Psi)	Power (V)	Out-put (V)
Main pump power control shift control pressure Swing motion detect pressure (R · L) CHP start pressure Remote control pressure (Front · Rear · 3rd · Swing · Boom) Motor control pressure (Front · Rear · 3rd)	9999430134	0 to 3 (0 to 435)	5	0.5 to 4.5
Swing pump pressure Independence confluence select Q max cut pressure	9999430139	0 to 50 (0 to 7252)	5	0.5 to 4.5

NOTE

9999430134	9999430139
Pressure range : 0 to 3.0 MPa Voltage Vcc : 5.0 ± 0.5 VDC Out-put : 1/10 Vcc =0.5 V to 4.5 V Tightning torque : 32 N-m max (26.7 ft-lbs)	Pressure range : 0 to 50 MPa Voltage Vcc : 5.0 ± 0.5 VDC Out-put : 1/10 Vcc =0.5 V to 4.5 V Tightning torque : 73.5 N-m max (54.2 ft-lbs)

GN52S00002P1

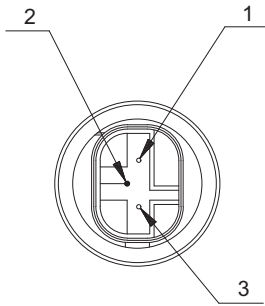

Location of connector terminal No.

- 1. COMMON
- 2. OUT - PUT (+)
- 3. POWER (+)

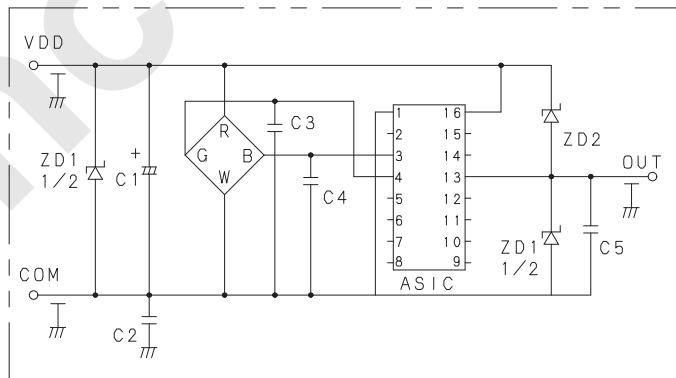
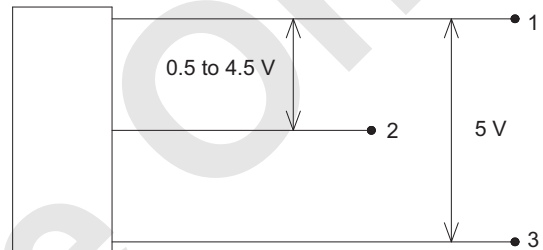
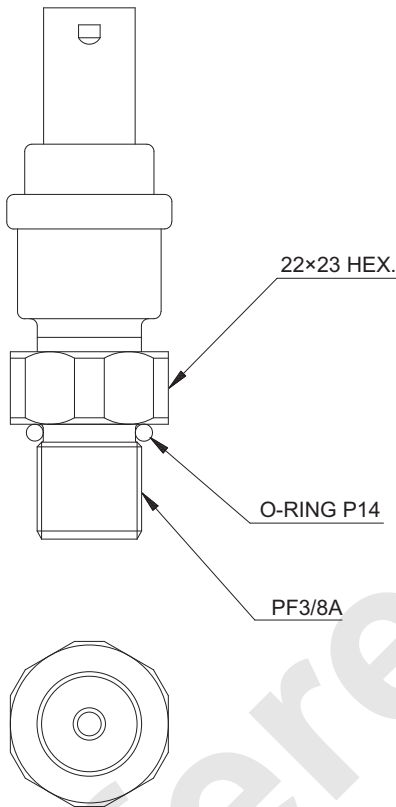

Use	Part number	Pressure range MPa (psi)	Power (V)	Out-put (V)
Clutch pressure (Front • Rear • 3rd)	9999426022	0 to 19.6	5	0.5 to 4.5
Control pressure (Primary side)		(0 to 2842)		

NOTE

9999426022

Tightening torque : 73.5 N-m

10. ELECTRIC SYSTEM

10.1.8 INCLINATION SENSOR

9999431869

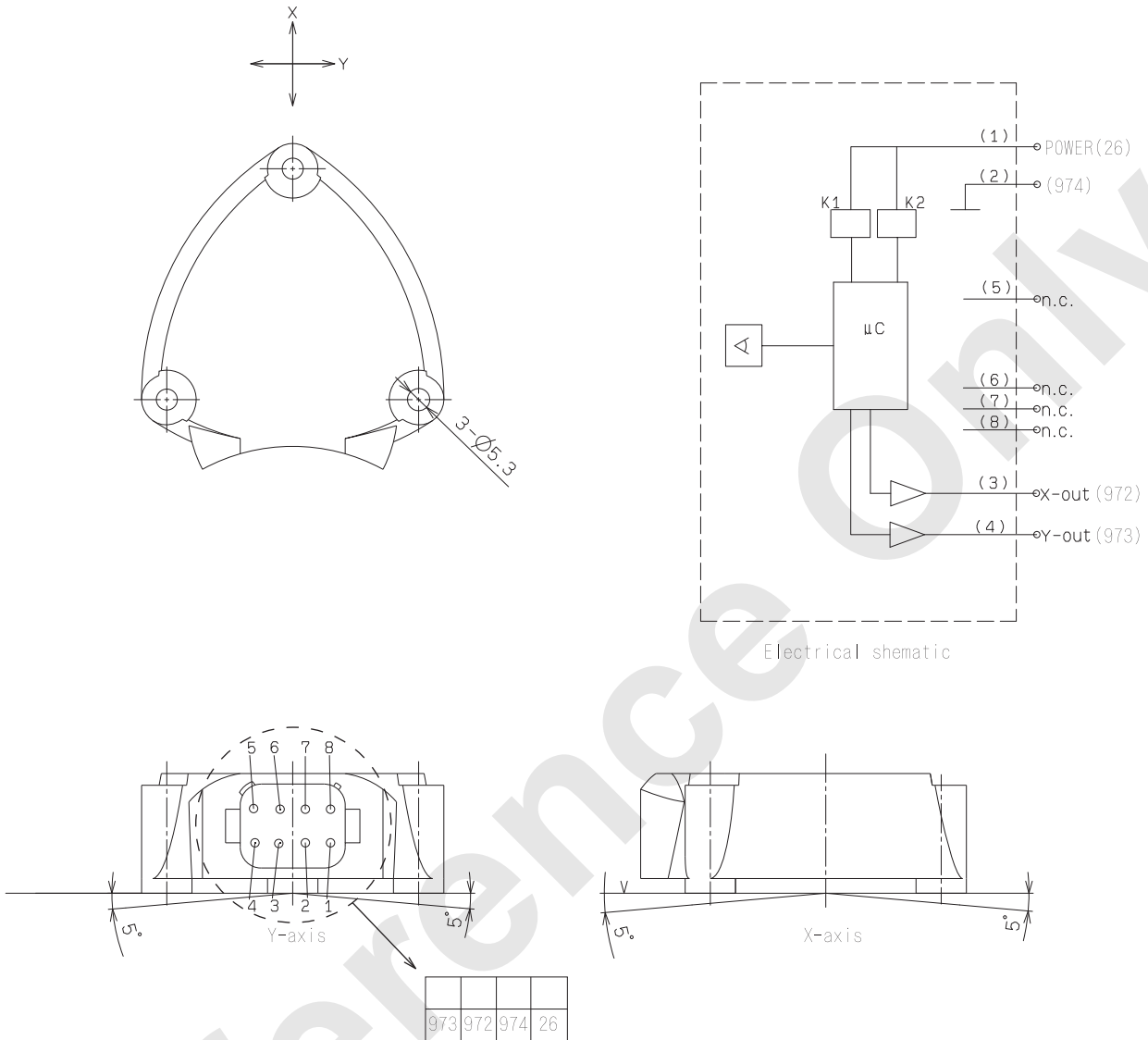

Type	: N4AA20010	Resolution	: 0.04°
Specification		Linear error	: 1%typ. of angle range
Angle range	: ±5°	Recurrence accuracy	: ±0.2°typ.
Power source	: 10 to 30VDC	Temperature drift	: 1.3% typ.
Power consumption	: typ.22mA	Protection class	: IP 67
Output	: X-axis 0.5 to 4.5V	Temperature range	: -40 to 70°C
	: Y-axis 0.5 to 4.5V	Vibration resistance	: Endurance 10 to 500HZ Amplitude 3 mm width X.Y.Z, direction 96h (about 20G)
Load resistance	: min 10kΩ	Impact resistance	: Endurance 500/s ² (about 50G) width X.Y.Z, direction about 10th
Zero adjustment	: ±5°		

10.1.9 BUZZER UNIT

9999431928

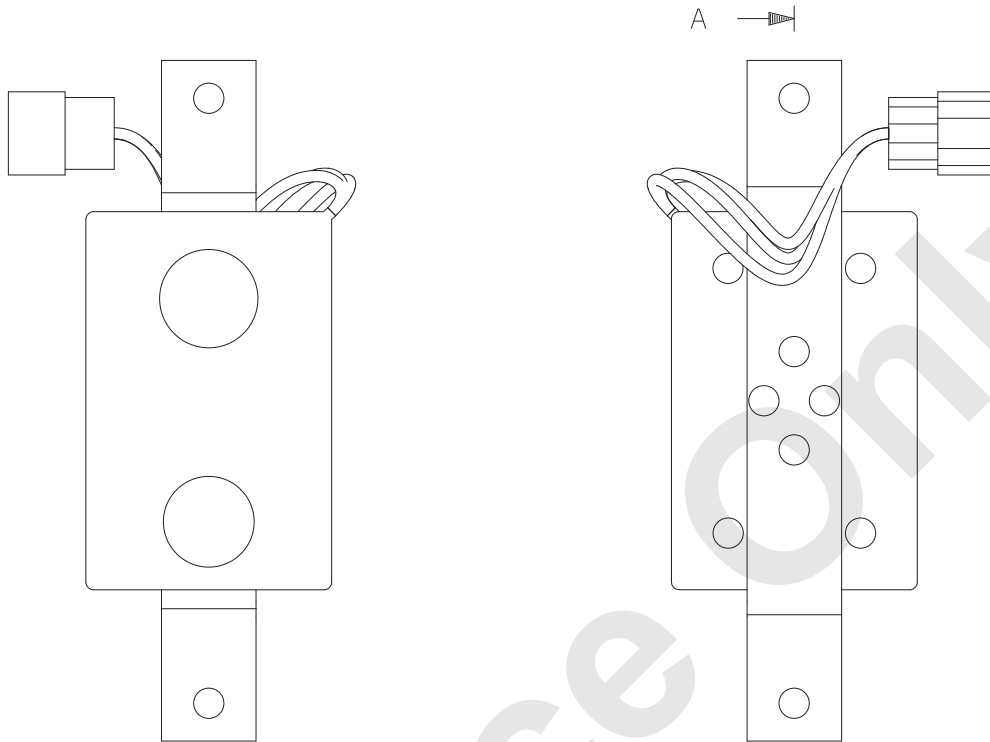

✕	
184	185
E	E

CN-240

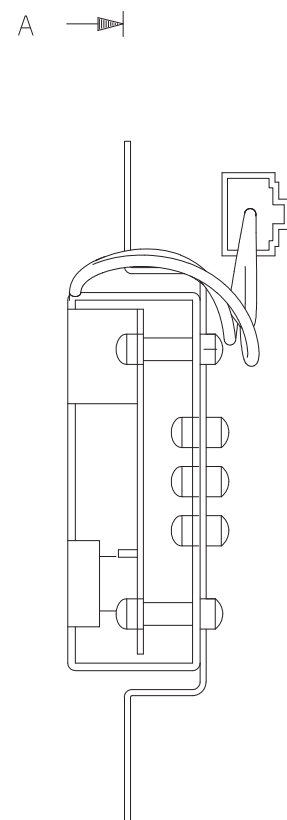

SECTION A-A

10. ELECTRIC SYSTEM

Buzzer to be used	High-pitched tone	FDK corp.	EB2210A-38C-12V
	Low-pitched tone	Bass Star precession corp.	TMX-12F
Rated Volt	24V		
Work range (Volt)	19 to 32V		
Working temperature range	-10 to 60°C		
Storage temperature range	-20 to 70°C		
Humidity	0 to 90%		
Sound volume	75db/30cm MIN		
Consumption elec. current	Max 50 mA		

10.1.10 RELAY BOX

1. ARRANGEMENT OF CONNECTOR

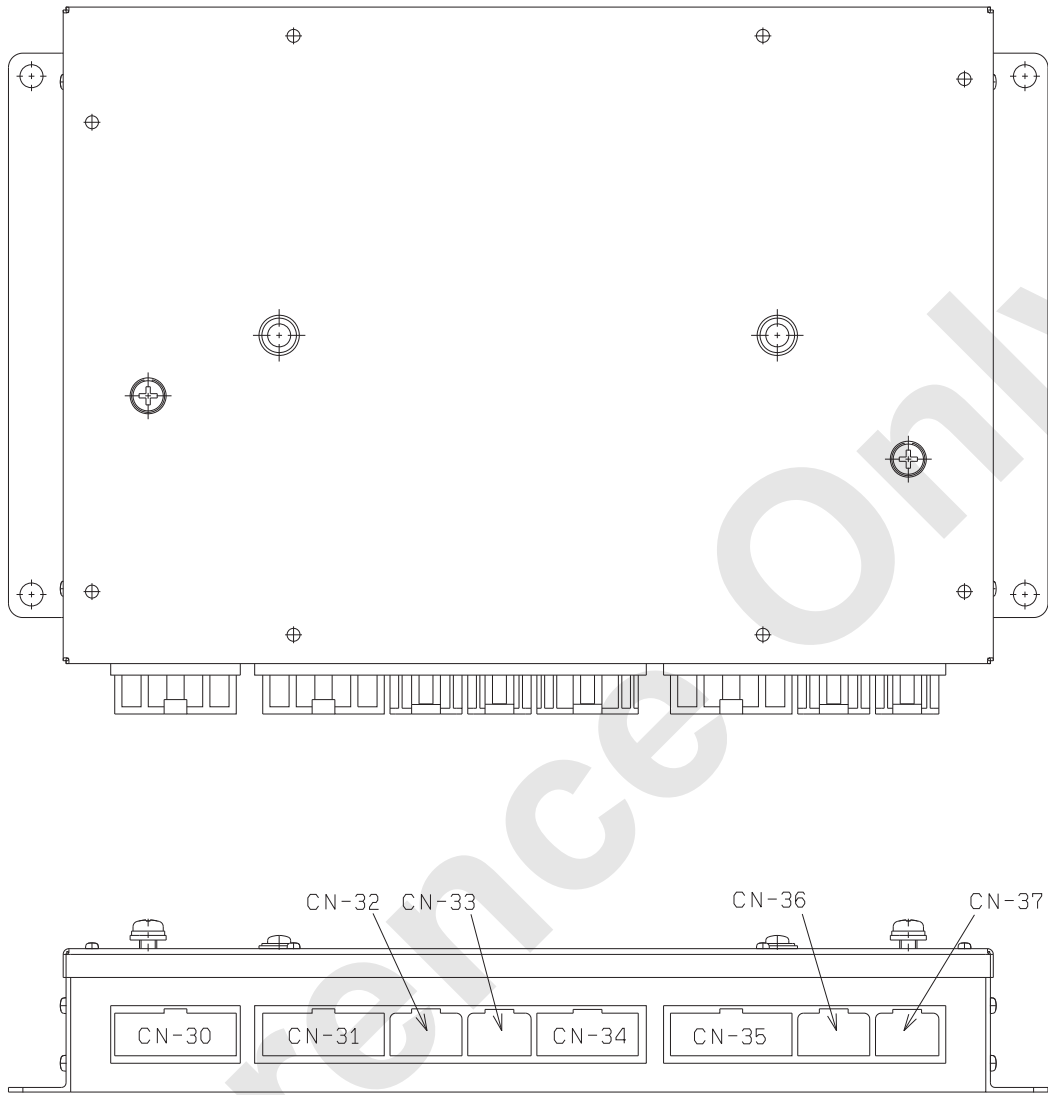

10. ELECTRIC SYSTEM

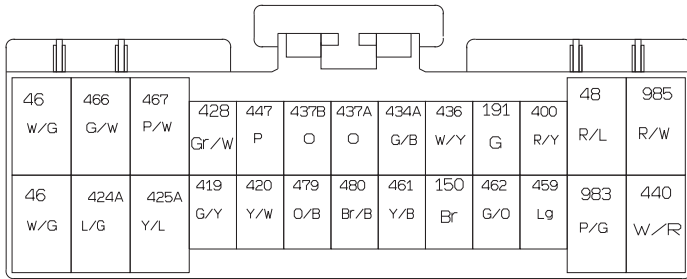

CN-30M
26MA-HB_GY

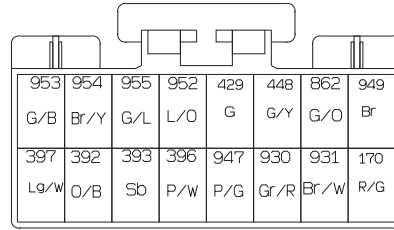

CN-32M
16MA-HB_GY

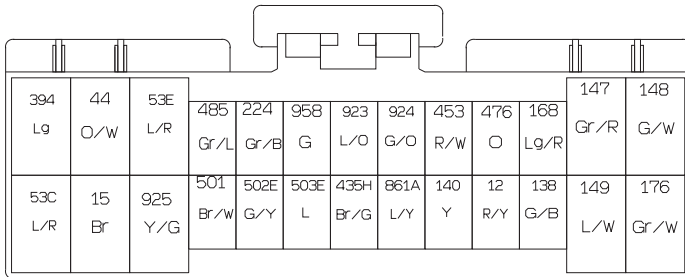

CN-31M
26MA-HB_GY

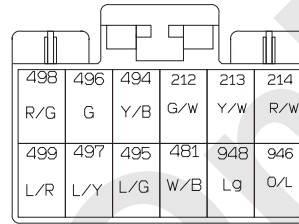

CN-33M
12MA-HBA_GY

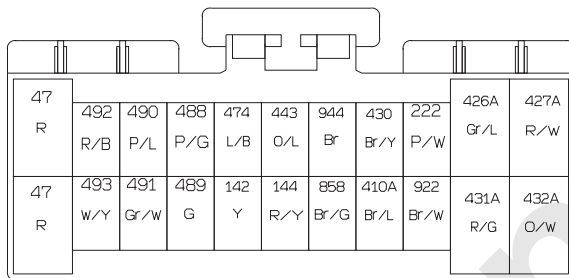

CN-34M
22MA-HB_GY

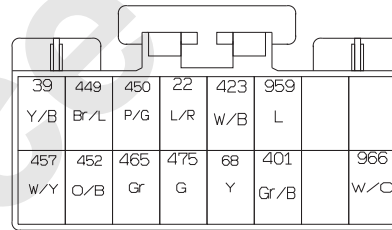

CN-36M
16MA-HB_GY

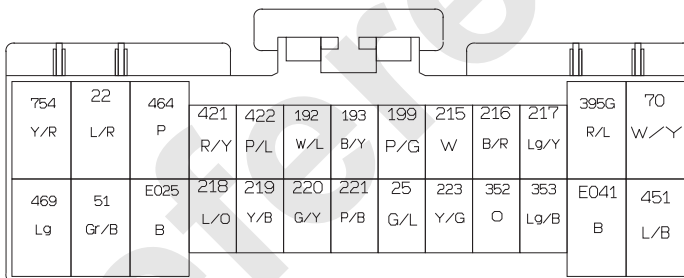

CN-35M
26MA-HB_GY

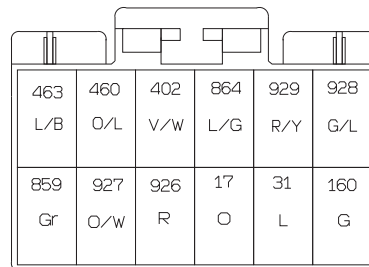

CN-37M
12MA-HB_GY

No.	Name	No.	Name
RL-1	Generation detect	RL-37	DPR Regeneration
RL-2	Safety	RL-38	Swing flasher (L)
RL-3	Separate oil cooler motor	RL-39	Swing flasher (R)
RL-4	AIS	RL-40	Pump Qmax cut
RL-5	Starter lock	RL-41	CLM
RL-6	Certify release	RL-42	ESM
RL-7	Engine stop	RL-43	CLA
RL-8	Remocon horn	RL-44	ESA
RL-9	Swing parking control	RL-45	CLT
RL-10-1	Swing parking 1	RL-46	EST
RL-10-2	Swing parking 2	RL-47	Front free select
RL-12	Swing parking 3	RL-48	Rear free select
RL-13	Pilot pressure cut	RL-49	Third free select
RL-14	Swing hi/lo pressure select	RL-50-1	Jib over hoist 1
RL-15	Swing neutral brake select	RL-50-2	Jib over hoist 2
RL-16	Propel alarm	RL-51	No. 2 limit
RL-17	Voice alarm	RL-53	Boom over hoist
RL-18	Hyd. pressure select (SOL45)	RL-54	Self removal select
RL-19	Hyd. pressure select (SOL44)	RL-55	Assy / disassy select
RL-20	Hyd. oil heat	RL-56	Mast model self removal select
RL-21	Engine restart	RL-57-1	Jib mode select 1
RL-22-1	MC1 bypass (left swing stop +)	RL-57-2	Jib mode select 2
RL-22-2	MC1 bypass (left swing stop -)	RL-58-1	Bend- prevent relay (R. upper)
RL-22-3	MC1 bypass (right swing stop +)	RL-58-2	Bend- prevent relay (L. upper)
RL-22-4	MC1 bypass (right swing stop -)		
RL-22-5	MC1 bypass (main pump 1 +)		
RL-22-6	MC1 bypass (main pump 1 -)		
RL-22-7	MC1 bypass (main pump 2 +)		
RL-22-8	MC1 bypass (main pump 2 -)		
RL-22-9	MC1 bypass (boom pump +)		
RL-22-10	MC1 bypass (boom pump -)		
RL-23	Key resume		
RL-24	ML bypass reset		
RL-25-1	ML bypass hold 1		
RL-25-2	ML bypass hold 2		
RL-27	Swing buzzer		
RL-28	Speed limit release		
RL-29	Speed limit		
RL-30	Outside indication lamp (green)		
RL-31	Outside indication lamp (yellow)		
RL-32	Outside indication lamp (red)		
RL-36	ML adjust mode select		

10. ELECTRIC SYSTEM

2. RELAY BOX SCHEMATIC

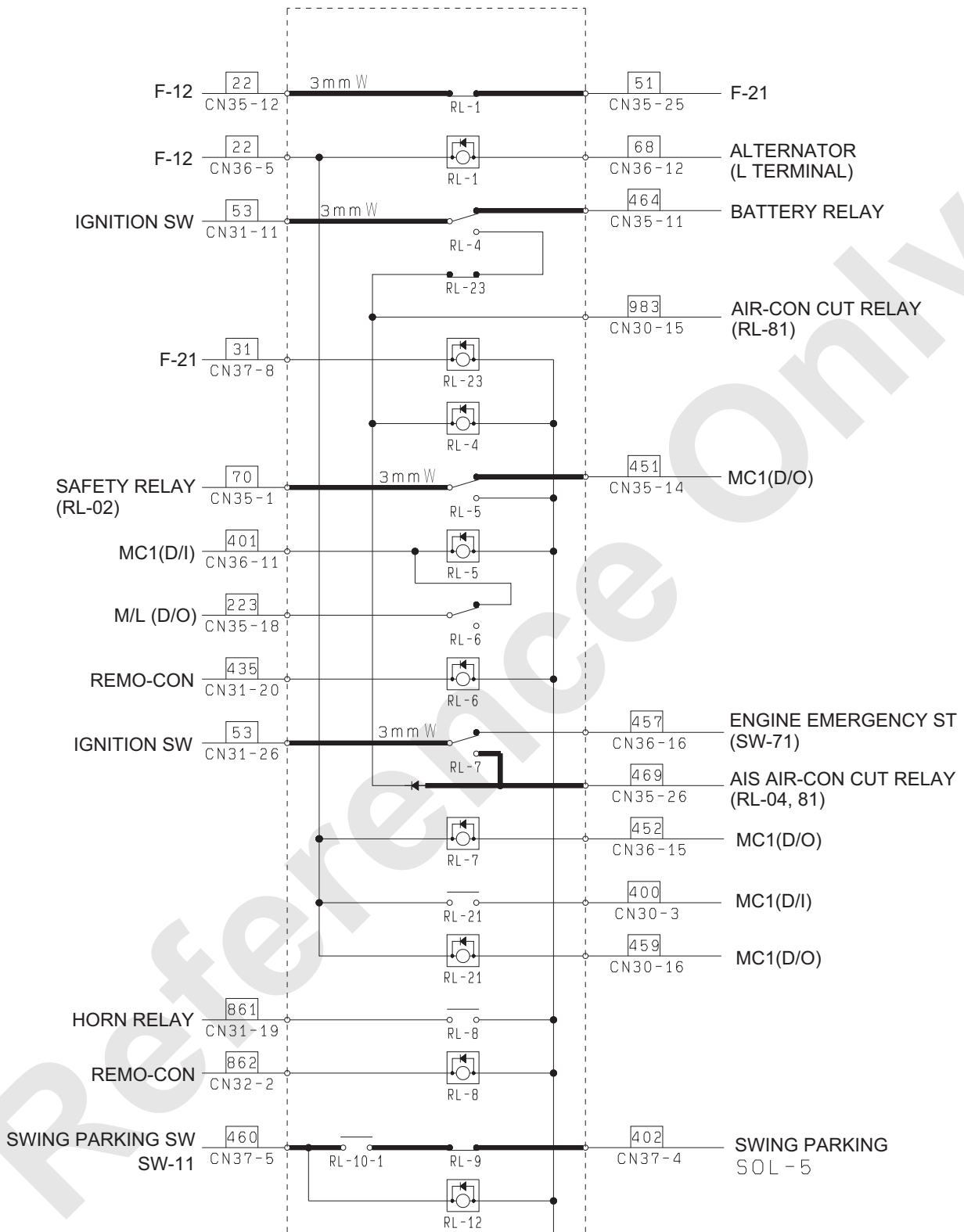

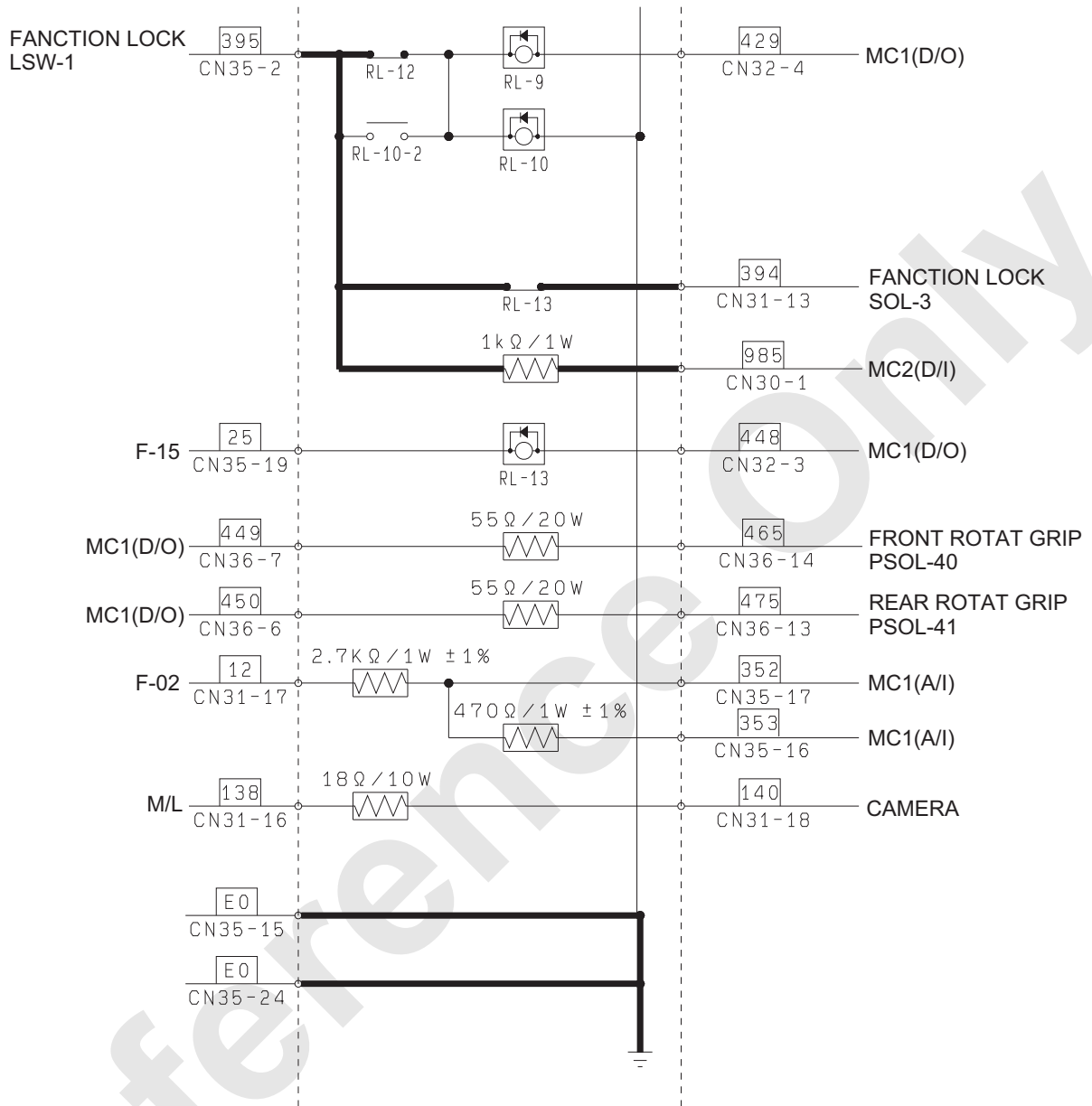

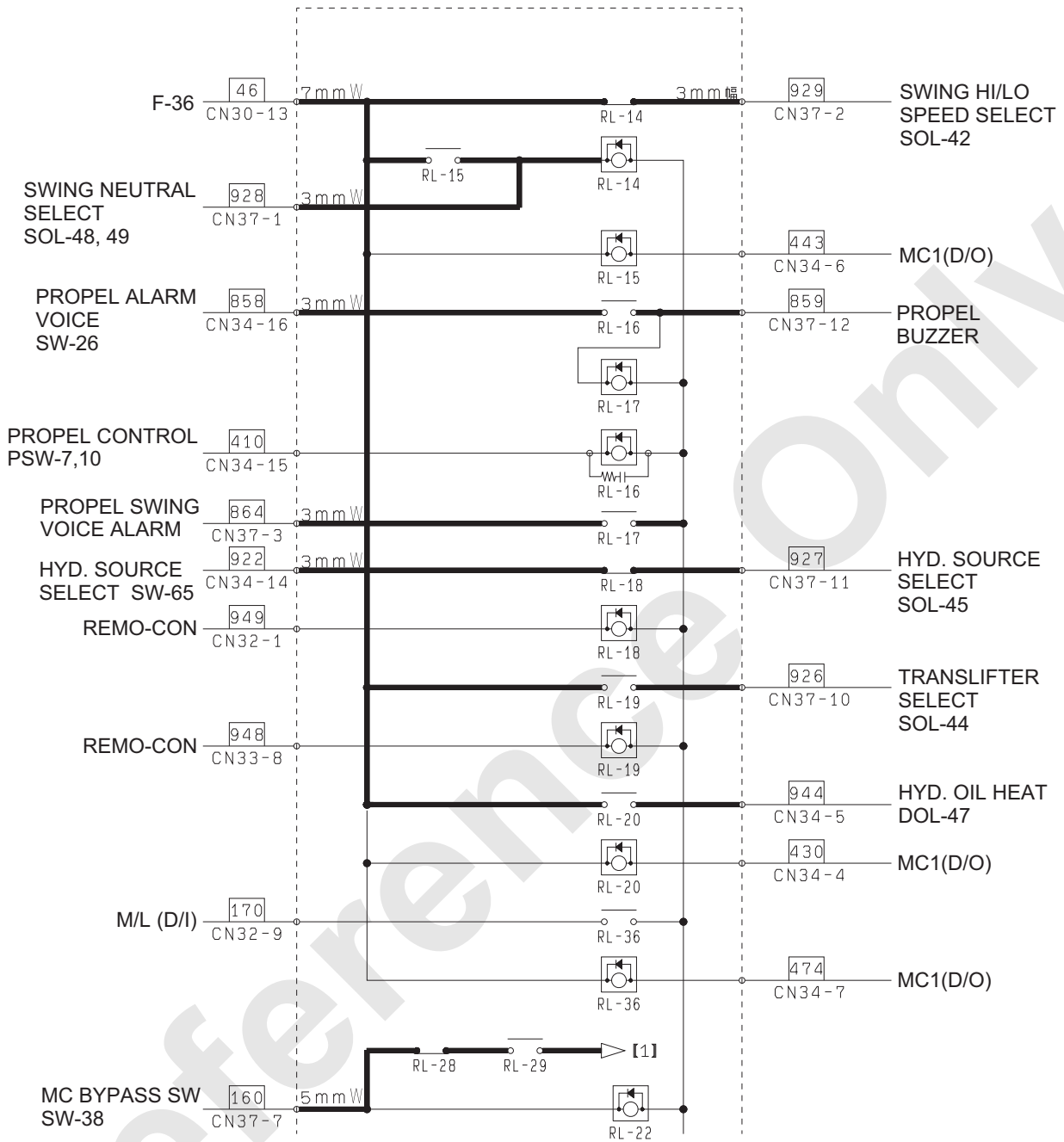

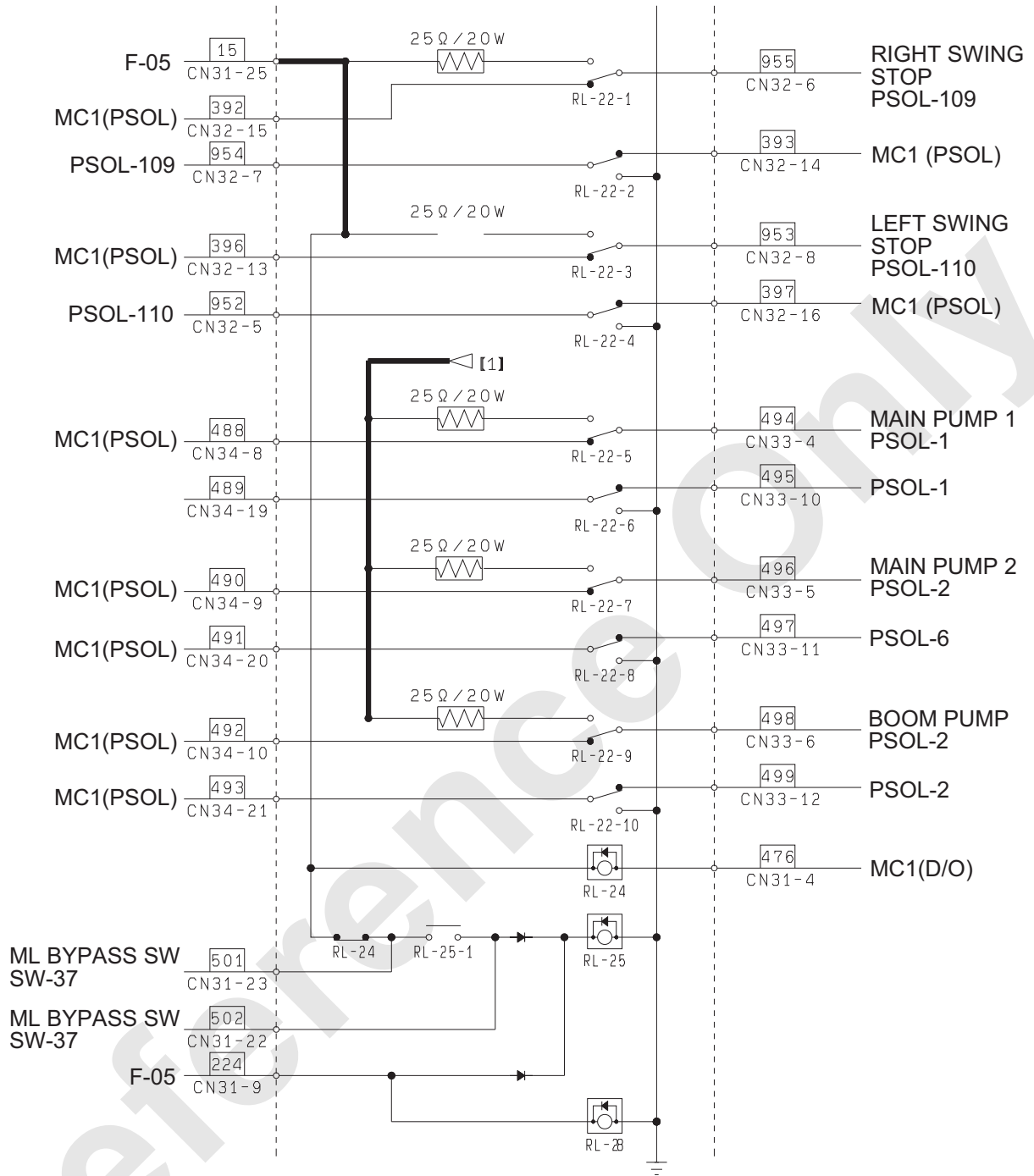

10. ELECTRIC SYSTEM

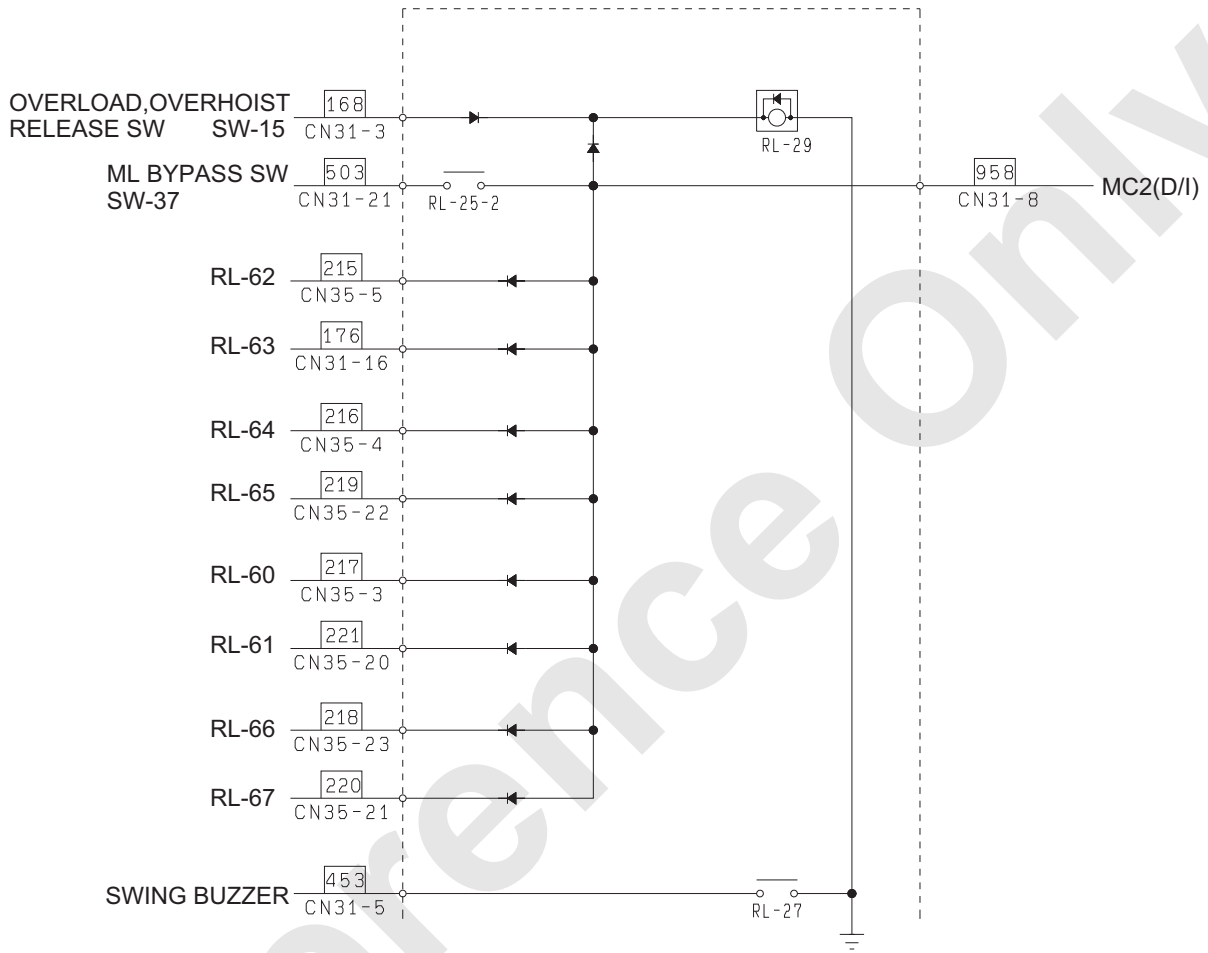

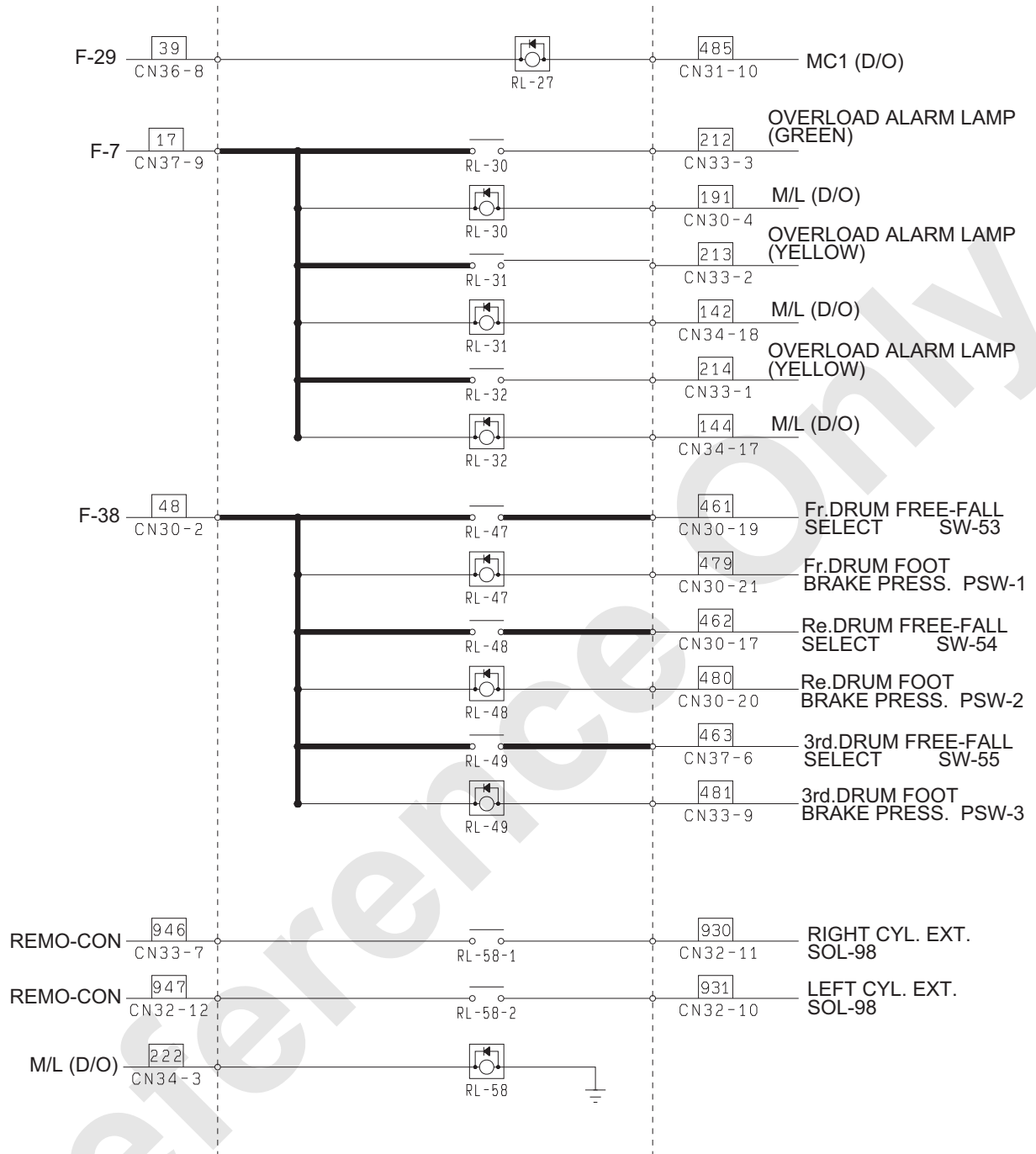

10. ELECTRIC SYSTEM

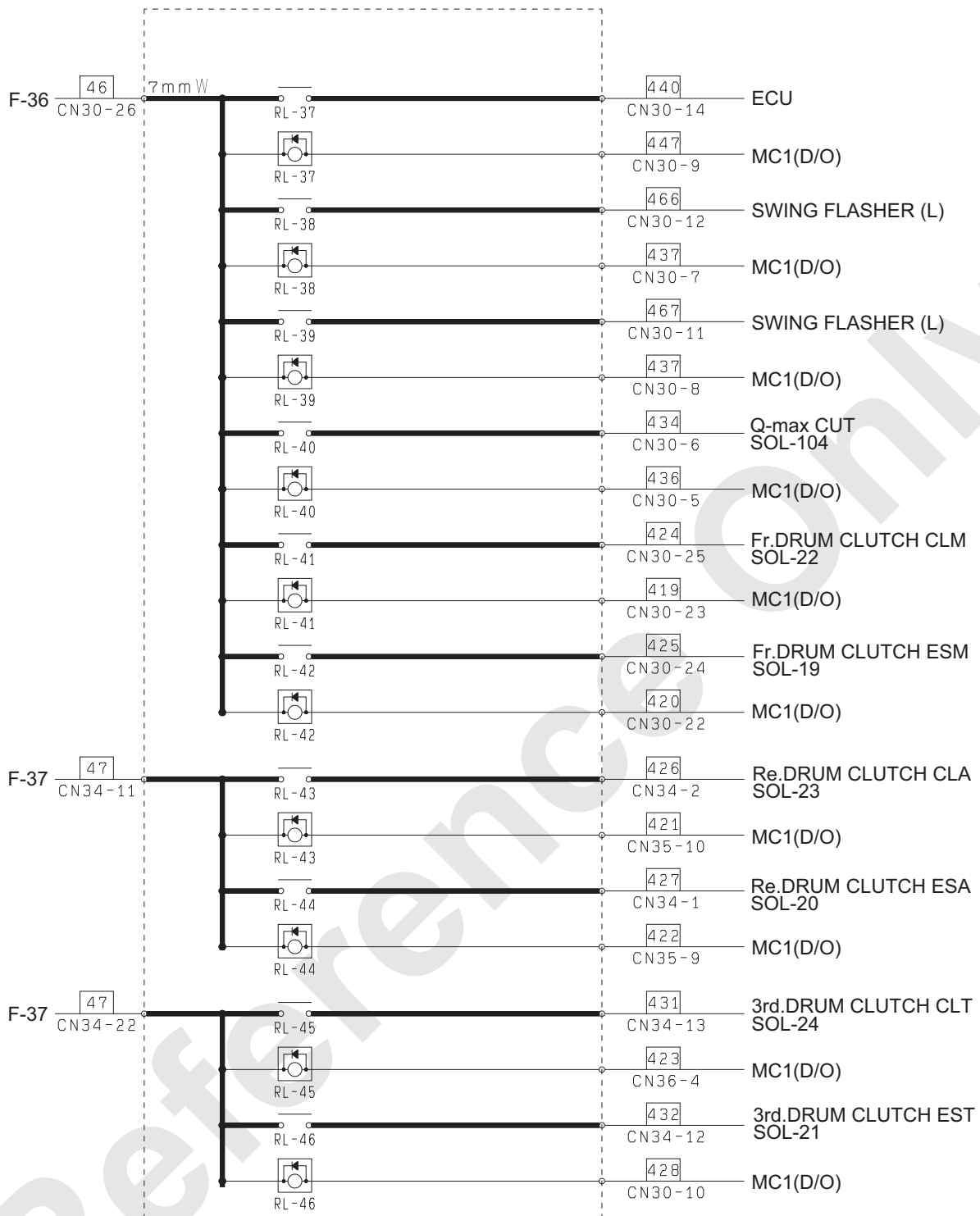

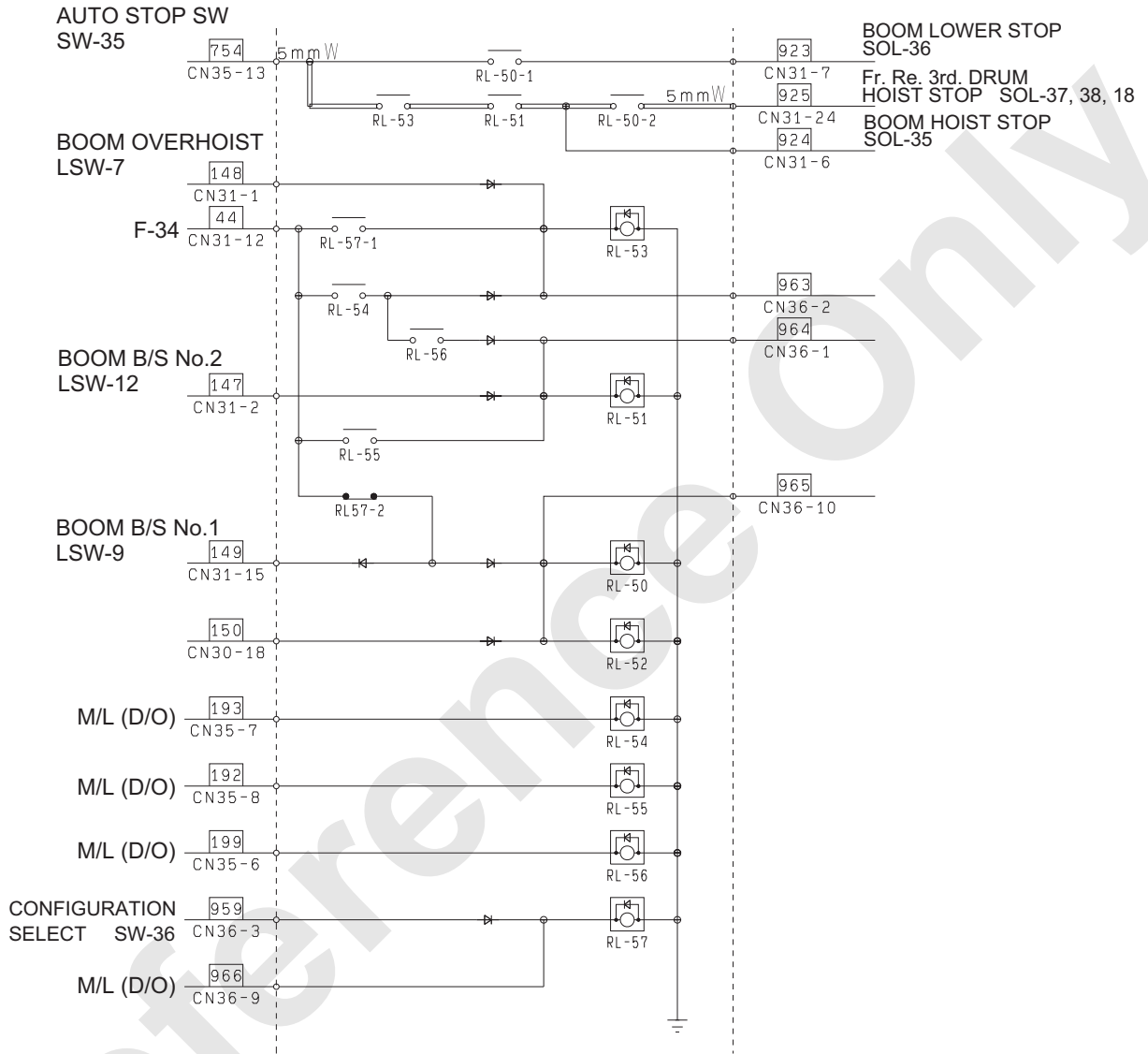

10. ELECTRIC SYSTEM

10.1.11 RELAY BOX

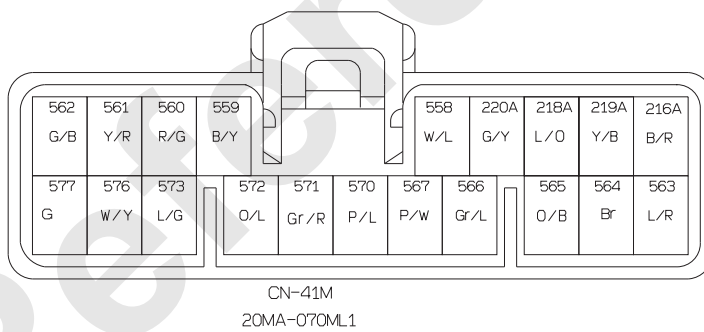
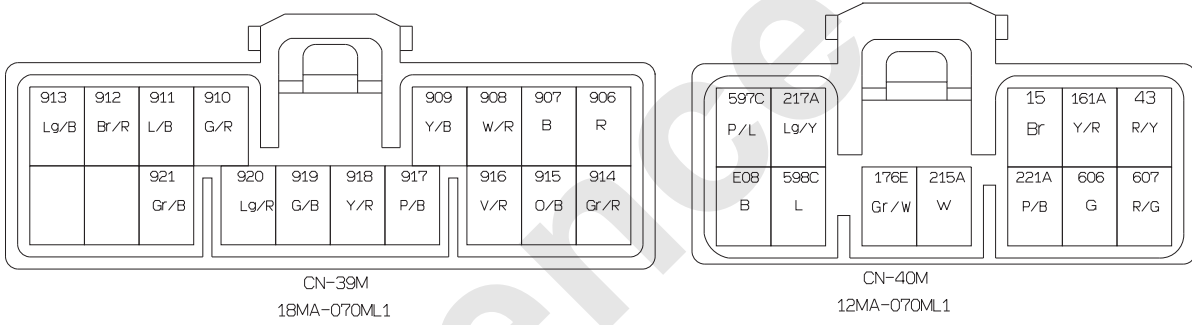
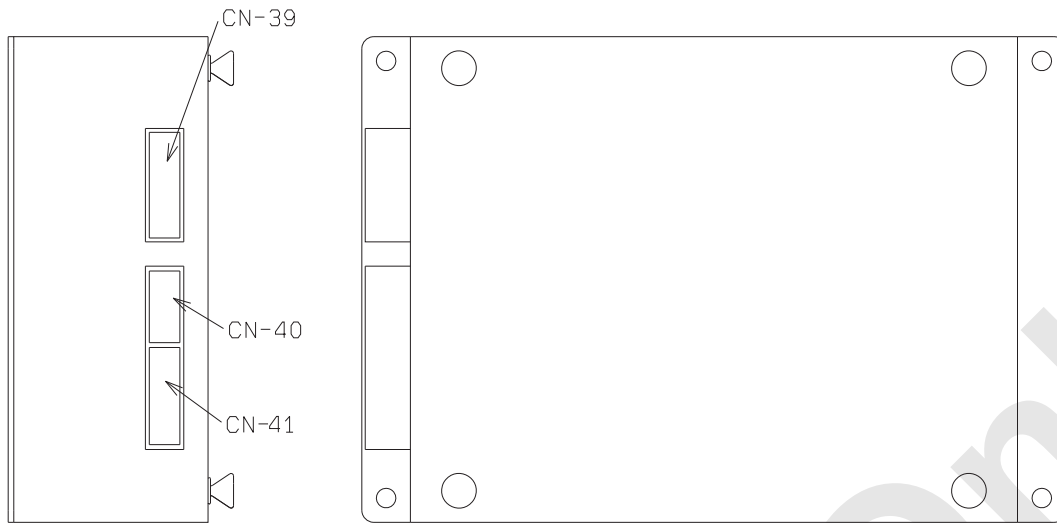

No.	Name
RL-60	Boom hoist raise stop relay
RL-61	Boom hoist lower stop relay
RL-62	Front raise stop relay
RL-63	Front lower stop relay
RL-64	Rear raise stop relay
RL-65	Rear lower stop relay
RL-66	Third raise stop relay
RL-67	Third lower stop relay
RL-68	MC bypass relay 1
RL-69	Independence, confluence select (F)
RL-70	Independence, confluence select (R)

Reference Only

10. ELECTRIC SYSTEM

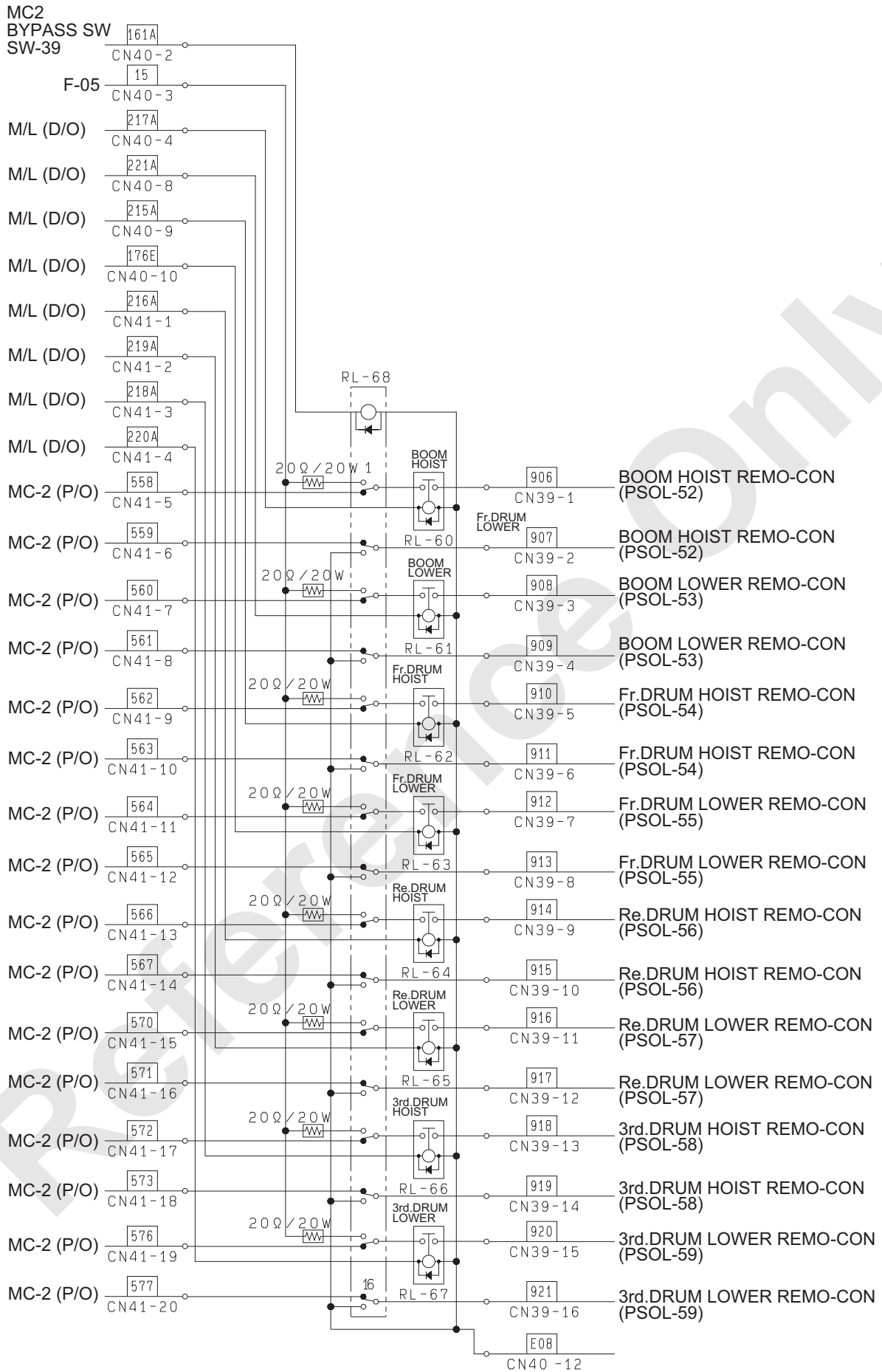

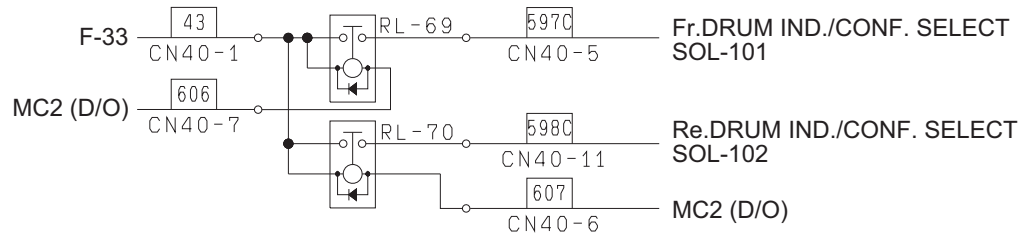

Reference Only

10. ELECTRIC SYSTEM

10.1.12 LOAD CELL (CRANE)

Model name :	LTP-S-50-KNSA10
Detective capacity:	Guy-cable support power
Rated capacity :	5 ton (49.03 KN)
Load capacity :	150%
Output voltage :	with no load $1V \pm 0.01V$ (at shipping) with rated load $5V \pm 0.040V$
Power source :	DC9V \pm 15V (under 30 mA)
Output resistance :	Appr. under 100 Ω
Insulated resistance :	500M Ω / above 25VDC
Non Lineality :	\pm 1% RO
Hysteresis :	\pm 1% RO
Temperature compensation range :	-30° C + 65° C
Temperature capacity :	-35° C to + 75° C
Temperature effect at zero point :	\pm 0.1% RO/° C
Temperature effect at output :	\pm 0.1% RO/° C
Output cable :	None apex classification 5P water proof plug AE770L14-05P
Vibration proof :	69.6 m/s 33Hz up/down for 4 hours and left/right, front/back for 2 hours.
Shock proof :	245 m/s, 15mS X,Y, Z (3 times each)
Water proof :	Conforms to IP67 or equivalent (JIS C0920 non-seaping type)
Durability :	5×10^5 times
Noise proof :	DC700V 100ns
Total integrity :	2.9% RO
Weight :	About 6 kg

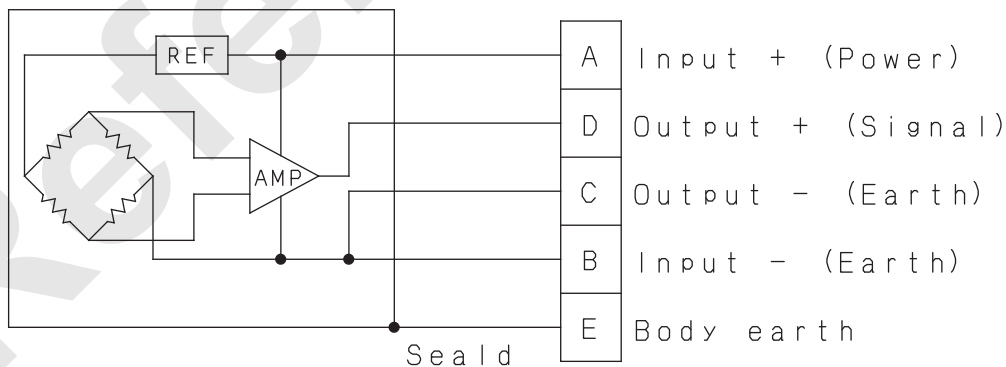

10.1.13 ANGLE SENSOR

Model name : MLA-901A-**C
 Detection capacity : Boom angle against ground
 Valid operating range : 0 to ± 90 degree
 Operation range : 360° endless
 Rated output sensitivity : 0.255V/V±0.5%
 Input voltage : 10V
 Input resistance : 50kΩ ± 5%
 Output resistance : (25000 + 141.6 X θ) Ω ± 5%
 Detecting accuracy : ±1°
 Initial inbalance : Set within±5°
 Insulate resistance : 100MΩ / 50VDC
 Output cable : Cab tire crolobren cable 0.5mm² X 4
 Cable analysis : Bending radius : R100, Tensile strength : 8kg
 Cable apex : 5P water proof plug AE776L14-05S+MT12-14+MS3180-14CAL
 Control method : Oil damper
 Monitor : With outside weight 0° , 30° , 60° , 90° Monitorable
 Case material : Plastic (Toshiba premix AP-902S)
 Surface treatment : Non, stripe (Black)
 Temperature range : -20 to 70° C
 Store temp. : -40 to 80° C
 Weight : appr. 1.2kg (main body), appr. 65g/m (cable)

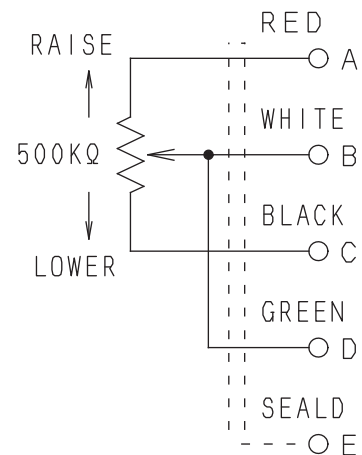
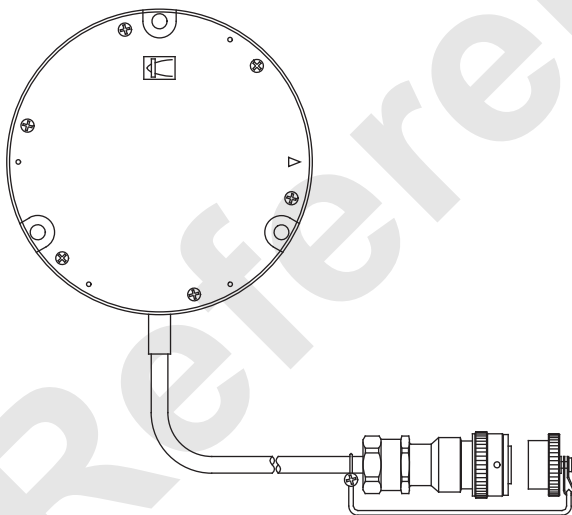

A-C Resistance : 50KΩ
 A-B Resistance (R) : 25000+141.6Xθ°

10. ELECTRIC SYSTEM

10.1.14 TROUBLESHOOTING OF EXHAUST GAS THIRD REGULATION ENGINE

1. FAILURE DIAGNOSIS FUNCTION

ECU always diagnoses whether or not the sensors malfunction while the key switch (M) is turned ON, and it lights on the diagnosis lamp when the sensor is judged as being malfunctioned and restores the place of failure at the same time to inform the operator of abnormality and ECU restricts the injection amount of fuel depending on the failure content.

It is possible to check the place of failure by using the diagnosis lamp or the diagnosis tool (HINO DX) via the DST-1 connector.

- Diagnosis lamp status while the key is turned ON
The lamp lights on when the key is ON (M) and engine is stopped as shown in the following chart. When the lamp does not go off even if the engine has been started, promptly stop the engine after avoiding danger because the system may have abnormality.

How to turn off the engine trouble detect lamp

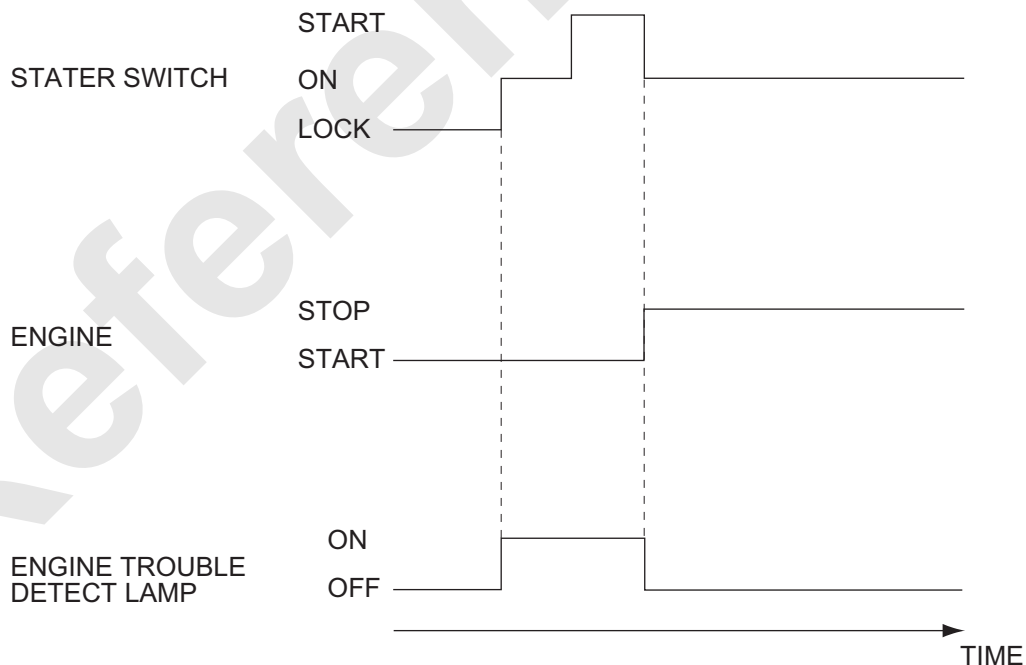

10.1.15 HOW TO CHECK THE FAILURE CONTENTS

1. Failure diagnosis code table (J08E Engine)

When the failure is detected by diagnosis lamp,
diag. code can be checked by connecting diag.
connector CN-878F, CN-879M
Component location related to diagnosis.

- Diag. lamp location
- Diag. connector CN-878F,CN-879M location
- DST-1 diag. connector location

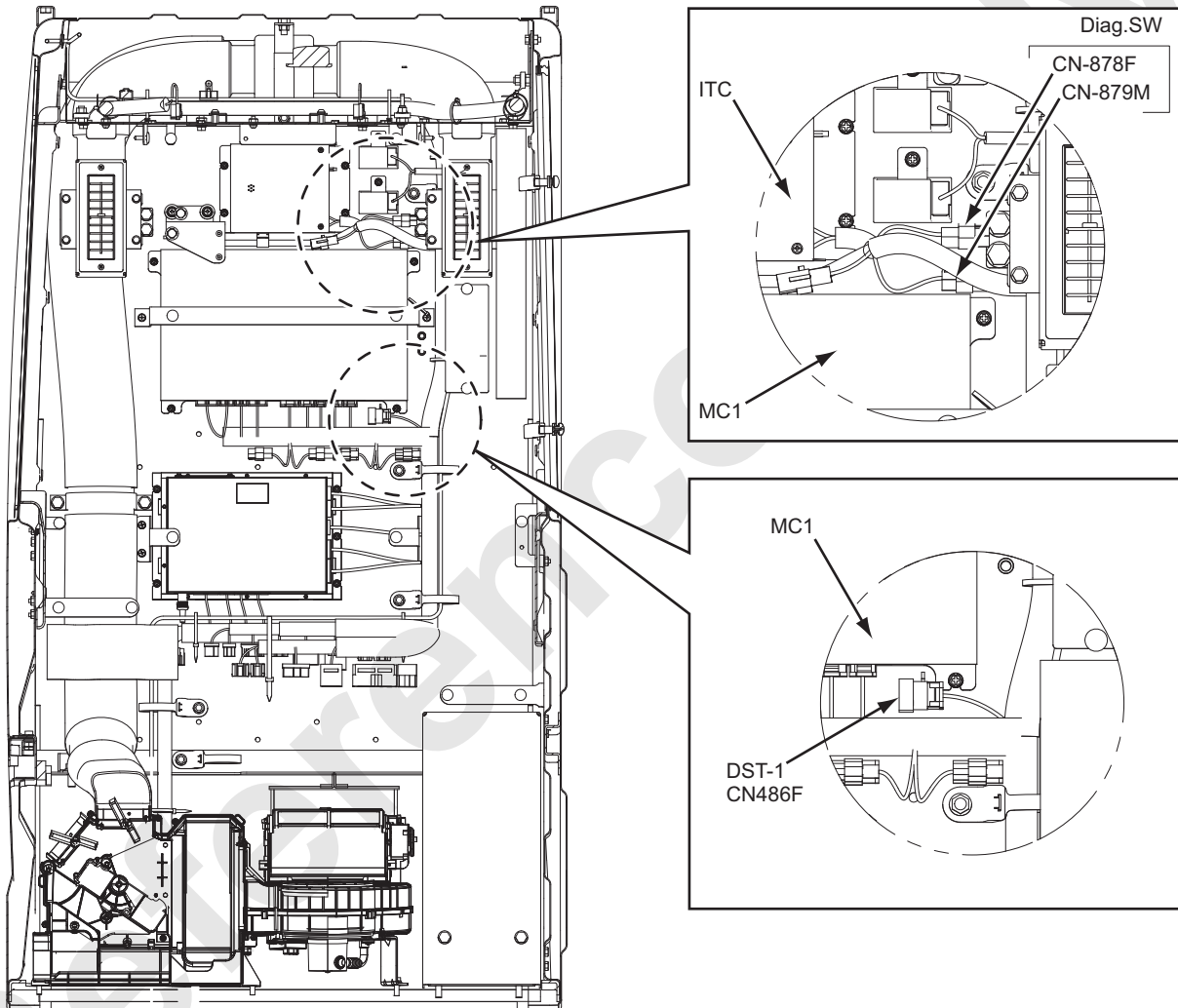

10. ELECTRIC SYSTEM

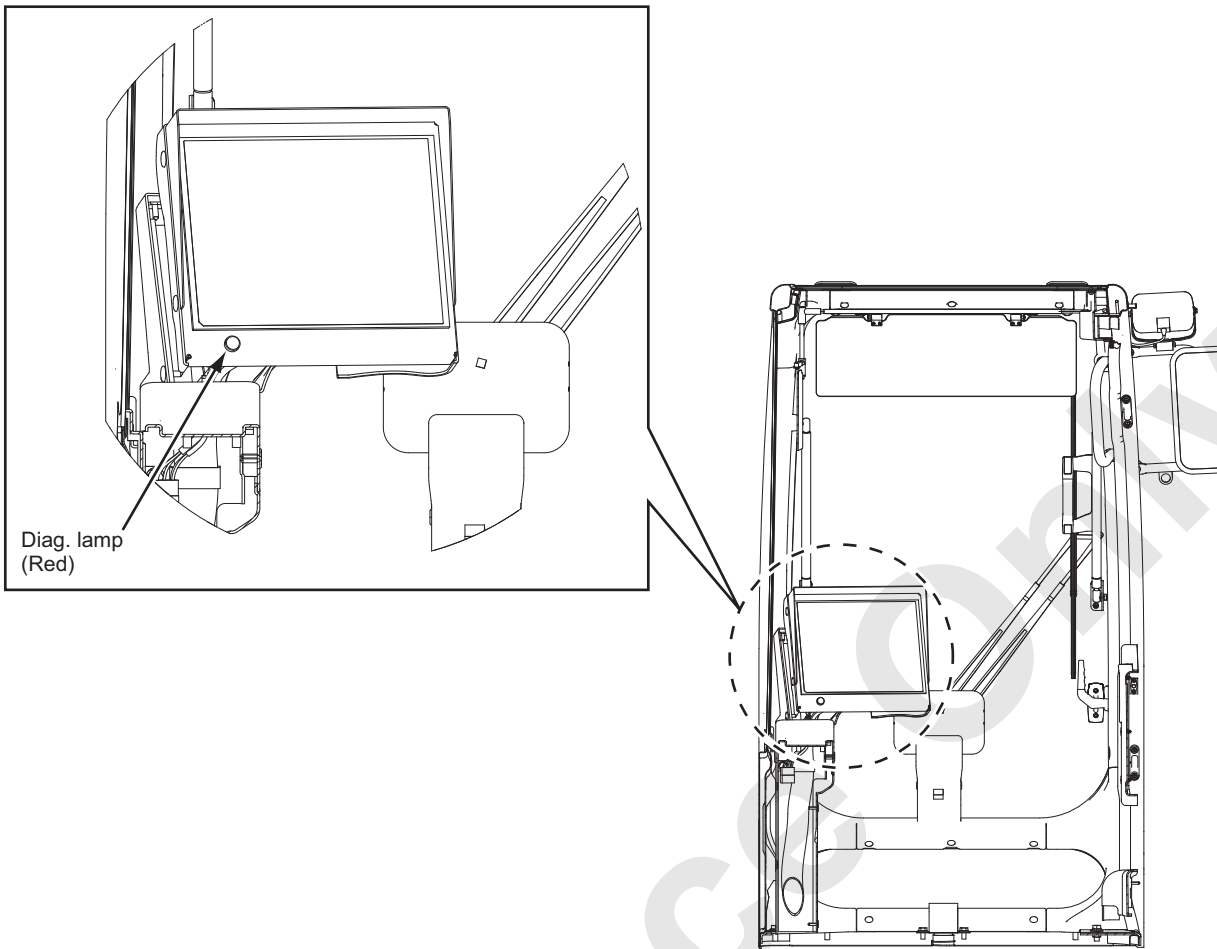

2. Table of Diagnosis codes (J08E-TI)

SAE code	System	TCCS digit code	Function	Check Lamp ON	Failure Level	Resume Timing	Injection volume limit	Engine Stop action	DPR Regeneration control	Failure judging condition	EGR Motion	Cause of failure	Remark				
														6	15	74	25
P0217	Each sensor system & related dialog	6	Over heat		2	Instant resume	Limited to 75%	No stop	-	Water temp 115°C		Over heat					
P2228	Each sensor system & related dialog	15	Air pressure sensor failure (Lo)	O	2	Instant resume	Limited to 75%	No stop	-	<1.90V		Sensor failure or unexpected high recognition					
P2229	Each sensor system & related dialog	15	Air pressure sensor failure (Hi)	O	2	Instant resume	Limited to 75%	No stop	-	>4.20V		Sensor failure or unexpected high recognition					
P119F	Each sensor system & related dialog	74	Commonrail press. sensor charact.abnormal	O	1	Instant resume	No limit	No stop	-	-		Sensor failure or harness wire breaking, short					
P0192	Each sensor system & related dialog	74	Commonrail press. Sensor failure (Lo)	O	2	After IG-OFF	No limit	No stop	No Regeneration	<0.64V	Stop	Sensor failure or harness wire breaking, short					
P0193	Each sensor system & related dialog	74	Commonrail press. Sensor failure (Hi)	O	2	After IG-OFF	No limit	No stop	No Regeneration	>4.78V	Stop	Sensor failure or harness wire breaking, short					
P1197	Each sensor system & related dialog	74	Commonrail sub press. Sensor failure (Lo)	-	1	Instant resume	No limit	No stop	-	<0.88V	-	Sensor failure or harness wire breaking, short	Due to main priority, no output limit since limited at BU main failure.				
P1198	Each sensor system & related dialog	74	Commonrail sub press. Sensor failure (Hi)	-	1	Instant resume	No limit	No stop	-	>4.82V	-	Sensor failure or harness wire breaking, short	Injection volume is suppressed and further output down				
P0237	Each sensor system & related dialog	25	Intake air press. (boost P.) sensor failure(Lo)	O	2	After IG-OFF	Limited to 75%	No stop	-	<0.19V	-	Sensor failure or harness wire breaking, short					
P0108	Each sensor system & related dialog	25	Intake air press. (boost P.) sensor failure(Hi)	O	2	After IG-OFF	Limited to 75%	No stop	-	>4.11	-	Sensor failure or harness wire breaking, short					
P0117	Each sensor system & related dialog	11	Water temp sensor failure (Lo)	O	2	Instant resume	Limited to 75%	No stop	-	<0.10V	Stop	Sensor failure or harness wire breaking, short					
P0118	Each sensor system & related dialog	11	Water temp sensor failure (Hi)	O	2	Instant resume	Limited to 75%	No stop	-	>4.77V	Stop	Sensor failure or harness wire breaking, short					
P0182	Each sensor system & related dialog	14	Combustion temp. sensor failure (Lo)	O	1	Instant resume	No limit	No stop	-	<0.10V	-	Sensor failure or harness wire breaking, short					
P0183	Each sensor system & related dialog	14	Combustion temp. sensor failure (Hi)	O	1	Instant resume	No limit	No stop	-	>4.88V	-	Sensor failure or harness wire breaking, short					
P2120	Each sensor system & related dialog	22	Both accel sensor failure	O	1	After IG-OFF	No limit	No stop	-	1 * 2 sensor failed	-	Sensor failure or harness wire breaking, short	※CAN is main control				
P2121	Each sensor system & related dialog	22	Accel sensor 1 voltage abnormal	-	1	After IG-OFF	No limit	No stop	-	-	-	Sensor failure or harness wire breaking, short	※CAN is main control				
P2122	Each sensor system & related dialog	22	Accel sensor 1 failure (Lo)	-	1	After IG-OFF	No limit	No stop	-	<0.30V	-	Sensor failure or harness wire breaking, short	※CAN is main control				
P2123	Each sensor system & related dialog	22	Accel sensor 1 failure (Hi)	-	1	After IG-OFF	No limit	No stop	-	>4.85V	-	Sensor failure or harness wire breaking, short	※CAN is main control				
P2126	Each sensor system & related dialog	22	Accel sensor 2 voltage abnormal	-	1	After IG-OFF	No limit	No stop	-	-	-	Sensor failure or harness wire breaking, short					
P2127	Each sensor system & related dialog	22	Accel sensor 2 failure (Lo)	-	1	After IG-OFF	No limit	No stop	-	<0.30V	-	Sensor failure or harness wire breaking, short					
P2128	Each sensor system & related dialog	22	Accel sensor 2 failure (Hi)	-	1	After IG-OFF	No limit	No stop	-	>4.85V	-	Sensor failure or harness wire breaking, short					
P1133	Each sensor system & related dialog	23	Work accel sensor. (Hi)	-	1	After IG-OFF	No limit	No stop	-	>4.85V	-	Sensor failure or harness wire breaking, short					
P0335	Rotating sensors system	13	Main rotate sensor failure. Both rotate sensor failure	O	2	Instant resume	Limited to 75%	No stop	-	-	Stop	When front rotate sensor failure, harness abnormal, both sensors failed starter ON at certain level.	Intake air volume is required in calculation.				
P0336	Rotating sensors system	13	Main rotate sensor pulse abnormal	O	2	Instant resume	Limited to 75%	No stop	-	-	Stop	Intake sensor abnormal, pulse area abnormal etc.	At fault Eng. is closed.				
P0016	Rotating sensors system	12	Main sub-sensor phase shift failure	O	1	Instant resume	No limit	No stop	-	-	-	Intake sensor abnormal, pulse area abnormal					
P0340	Rotating sensors system	12	Sub rotate sensor failure	O	1	Instant resume	No limit	No stop	-	-	-	Intake sensor abnormal, pulse area abnormal	Starting characteristics becomes slightly worse.				
P0341	Rotating sensors system	12	Sub rotate sensor pulse abnormal	O	1	Instant resume	No limit	No stop	-	-	-	Intake sensor abnormal, pulse area abnormal					
P0088	Supply pump system	69	Commonrail abnormal hi pressure (1st step)	O	1	After IG-OFF	No limit	No stop	-	-	-	Supply pump failure, harness abnormal					
P0088	Supply pump system	69	Commonrail abnormal hi pressure (2nd step)	O	1	After IG-OFF	No limit	No stop	-	-	-	Supply pump failure, harness abnormal					
P0088	Supply pump system	76	Commonrail pressure hi pressure abnormal	O	1	After IG-OFF	No limit	No stop	-	-	-	Supply pump failure, harness abnormal					
P0087	Supply pump system	76	Commonrail pressure under abnormal	O	2	After IG-OFF	Limited to 75%	No stop	No Regeneration	-	Stop	Supply pump failure, harness abnormal					
P0629	Supply pump system	75	Supply pump sol. v. 1 failure (no press./feed)	O	3	After IG-OFF	Limited to 75%	No stop	No Regeneration	-	Stop	S C V short (+B)	Half of cylinders do not inject and output is decreased accordingly.				
P0628	Supply pump system	73	Supply pump sol v. 1 failure (All delivery)	O	2	After IG-OFF	Limited to 75%	No stop	-	-	-	S C V drive system abnormal					
P2635	Supply pump system	76	Supply pump replace	-	1	After IG-OFF	No limit	No stop	-	-	-	S C V drive system abnormal					
P1211	Injector system	68	Injector common 1 failure (GND short)	O	3	After IG-OFF	No limit	No stop	No Regeneration	-	Stop	Injector power harness abnormal	No output limit. Inject inset is decreased into half, reduced cylinder running and speed variation becomes large.				
P1214	Injector system	68	Injector common 2 failure (GND short)	O	3	After IG-OFF	No limit	No stop	No Regeneration	-	Stop	Injector power harness abnormal					
P1212	Injector system	68	Injector common 1 failure (VB short, open)	O	3	After IG-OFF	No limit	No stop	No Regeneration	-	Stop	Injector power harness abnormal					
P1215	Injector system	68	Injector common 2 failure (VB short, open)	O	3	After IG-OFF	No limit	No stop	No Regeneration	-	Stop	Injector power harness abnormal					
P0201	Injector system	61	Injector 1 wire breaking	O	2	After IG-OFF	Limited to 75%	No stop	No Regeneration	-	Stop	Injector failed or injector harness abnormal (intake side)	No output limit. Failed cylinder does not inject and output is decreased accordingly.				
P0202	Injector system	62	Injector 2 wire breaking	O	2	After IG-OFF	Limited to 75%	No stop	No Regeneration	-	Stop	Injector failed or injector harness abnormal (intake side)					
P0203	Injector system	63	Injector 3 wire breaking	O	2	After IG-OFF	Limited to 75%	No stop	No Regeneration	-	Stop	Injector failed or injector harness abnormal (intake side)					
P0204	Injector system	64	Injector 4 wire breaking	O	2	After IG-OFF	Limited to 75%	No stop	No Regeneration	-	Stop	Injector failed or injector harness abnormal (intake side)					
P0205	Injector system	65	Injector 5 wire breaking	O	2	After IG-OFF	Limited to 75%	No stop	No Regeneration	-	Stop	Injector failed or injector harness abnormal (intake side)					
P0206	Injector system	66	Injector 6 wire breaking	O	2	After IG-OFF	Limited to 75%	No stop	No Regeneration	-	Stop	Injector failed or injector harness abnormal (intake side)					

SAE code	System	TCCS digit code	Function	Check Lamp ON	Failure Level	Resume Timing	Injection volume limit	Engine Stop action	D P R Regeneration control	Failure judging condition	EGR Malon	Cause of failure	Remark
P0263	Injector system	61	Inter-cylinder Carburation error# 1	-	1	After IS-OFF	No limit	No stop	-	-	-	-	-
P0266		62	Inter-cylinder Carburation error#2	-	1	After IS-OFF	No limit	No stop	-	-	-	-	-
P0269		63	Inter-cylinder Carburation error#3	-	1	After IS-OFF	No limit	No stop	-	-	-	-	-
P0272		64	Inter-cylinder Carburation error# 4	-	1	After IS-OFF	No limit	No stop	-	-	-	-	-
P0275		65	Inter-cylinder Carburation error# 5	-	1	After IS-OFF	No limit	No stop	-	-	-	-	-
P0278		66	Inter-cylinder Carburation error# 6	-	1	After IS-OFF	No limit	No stop	-	-	-	-	-
P0234	Turbo	34	Turbo over boost	0	3	Instant resume	Limited to 50%	No stop	-	-	-	Over boost ? Turbo failure	-
P0045	V N T System		VNT actuator failure 1 (major failure)	0	3	After IS-OFF	20% +rotate contid	No stop	-	-	-	-	-
			VNT actuator failure 2 (minor failure)	0	2	After IS-OFF	Limited to 75%	No stop	-	-	-	-	-
P00AF			VNT CONTROLLER FAILURE 1 (MAJOR FAILURE)	0	3	After IS-OFF	20% +rotate contid	No stop	-	-	-	-	Failure info. Received from VNT controller
			VNT CONTROLLER FAILURE 2 (MAJOR FAILURE)	0	2	After IS-OFF	Limited to 75%	No stop	-	-	-	-	-
P0611			ECU CHARGE CIRCUIT FAILURE (Lo)	0	3	After IS-OFF	Limited to 75%	No stop	No Regeneration	-	-	-	Stop
P0200		ECU CHARGE CIRCUIT FAILURE (Hi)	0	2	After IS-OFF	Limited to 75%	No stop	No Regeneration	-	-	-	Stop	
P0605	E C U Main body system		Flash ROM abnormal	0	2	After IS-OFF	Limited to 75%	No stop	No Regeneration	-	-	-	-
P0606			GPU failure (Hard detect)	0	3	Instant resume	Forcible stop	Stop	-	-	-	-	-
P0607			GPU monitor IC abnormal	0	3	Instant resume	Limited to 75%	No stop	No Regeneration	-	-	-	-
P1601			QR code failure	0	1	Instant resume	No limit	No stop	-	-	-	-	-
P2100			DC motor vrbt breakage drive duty vrbt breaka	0	1	After IS-OFF	No limit	No stop	-	-	-	-	-
P2103			DC motor_GND short	0	3	After IS-OFF	Limited to 50%	No stop	-	-	-	-	-
P2101		Intake air orifice valve		Intake air orifice sensor sticking	0	3	After IS-OFF	Limited to 50%	No stop	-	-	-	Stop
P0122			Intake air orifice opening sensor failure (Lo)	0	3	After IS-OFF	Limited to 50%	No stop	-	-	-	-	-
P0123		Intake air orifice opening sensor failure (Hi)	0	3	After IS-OFF	Limited to 50%	No stop	-	-	-	-	-	
P1458	E G R related	81	EGR system failure 1 (major failure)	0	2	After IS-OFF	Limited to 75%	No stop	No Regeneration	-	-	-	-
P1459			EGR system failure 2 (major failure)	0	2	After IS-OFF	Limited to 75%	No stop	No Regeneration	-	-	-	-
P06D3	Air flow sensor	5	Air flow sensor power (+B)	-	1	Instant resume	No limit	No stop	-	-	-	-	-
P06D4			Air flow sensor power (GND)	-	1	Instant resume	No limit	No stop	-	-	-	-	-
P0104			Air flow sensor abnormal 1 (High frequent)	0	2	After IS-OFF	Limited to 75%	No stop	-	-	-	-	<0.85kHz
P0104			Air flow sensor abnormal 2 (Low frequent)	0	2	After IS-OFF	Limited to 75%	No stop	-	-	-	-	> 9.80kHz
P0112	Intake air sensor	17	Intake air temp. sensor abnormal (Low)	0	1	Instant resume	No limit	No stop	-	-	-	-	<0.05V
P0113		Intake air temp. sensor abnormal (High)	0	1	Instant resume	No limit	No stop	-	-	-	-	-	>4.55V
P200C		D P F meltdown failure 1	0	1	DPR-reset	No limit	No stop	-	-	-	-	-	-
P244A		D P F meltdown failure 2	0	3	DPR-reset	Limited to 50%	No stop	-	-	-	-	-	-
P2463	DRP related	82	D P F abnormal clog 1	0	3	DPR-reset	Limited to 50%	No stop	-	-	-	-	-
P244B			D P F abnormal clog 2	0	3	DPR-reset	Limited to 50%	No stop	-	-	-	-	-
P2458			DRP catalyst deterioration 1	0	3	DPR-reset	Limited to 50%	No stop	No Regeneration	-	-	-	-
P24A2			DRP catalyst deterioration 2	0	3	DPR-reset	Limited to 50%	No stop	No Regeneration	-	-	-	-
P1427	Pressure difference sensor system	28	Pressure difference sensor abnormal (Lo)	0	3	After IS-OFF	Limited to 50%	No stop	-	-	-	-	<0.50V
P1428			Pressure difference sensor abnormal (Hi)	0	3	After IS-OFF	Limited to 50%	No stop	-	-	-	-	>4.46V
P0545			Exhaust air temp. sensor1 abnormal (Lo)	0	1	Instant resume	No limit	No stop	No Regeneration	-	-	-	<0.05V
P0546			Exhaust air temp. sensor1 abnormal 1 (Hi)	0	1	Instant resume	No limit	No stop	No Regeneration	-	-	-	>4.96V
P2032	Exhaust air temp. system		Exhaust air temp. sensor1 abnormal 2 (Lo)	0	1	Instant resume	No limit	No stop	-	-	-	-	<0.05V
P2033			Exhaust air temp. sensor1 abnormal 2 (Hi)	0	1	Instant resume	No limit	No stop	-	-	-	-	>4.96V
P0642			Sensor power 1 abnormal (Lo)	-	1	Instant resume	No limit	No stop	-	-	-	-	-
P0643	Sensor voltage system	5	Sensor power 1 abnormal (Hi)	-	1	Instant resume	No limit	No stop	-	-	-	-	-
P0652			Sensor power 2 abnormal (Lo)	-	1	Instant resume	No limit	No stop	-	-	-	-	-
P0653			Sensor power 2 abnormal (Hi)	-	1	Instant resume	No limit	No stop	-	-	-	-	-

SAE code	System	TCCS digit code	Function	Check Lamp ON	Failure Level	Resume Timing	Injection volume limit	Engine Stop action	D P R Regeneration control	Failure judging condition	EGR Motion	Cause of failure	Remark	
P0540	Vehicle system	53	Pre-heating device failure	○	1	Instant resume	No limit	No stop	—	—	—	Pre-heating device (Shoprt + B, GND)		
P0686	Vehicle system	51	Main relay failure	○	1	Instant resume	No limit	No stop	—	—	—	Power system failure		
P0219	Vehicle system	7	Engine over run	○	1	Instant resume	No limit	No stop	—	—	—	Over run	Intake throttle full close	
P0617	Vehicle system	46	Starter switch failure	—	1	Instant resume	No limit	No stop	—	—	—	Switch failure (Shorted continuously)	Low temp string worsen	
U1001	Transmission related	9	CAN1 failure	○	1	Alter IG-OFF	No limit	No stop	—	—	—			
U110A			Transmission lost_TSC1 (isolation command)	○	1	Alter IG-OFF	No limit	No stop	—	—	—	—		
U0073			CAN2 failure	○	3	Alter IG-OFF	Limited to 50%	No stop	No stop	No Regeneration	—	Stop		
U1122			Transmission lost_EGR	○	2	Alter IG-OFF	Limited to 75%	No stop	No stop	—	—	Stop		
U1123			Transmission lost_VIN T	○	3	Alter IG-OFF	Limited to 50%	No stop	No stop	No Regeneration	—	—		

*How to output diag. code

- SAE code : This is output when failure is confirmed with failure diagnosis. Failure code is indicated on present and past.
Past failure can be erased only with failure diagnosis tool.

- 2 digit code : Check for blinking number of engine check clamp.
Present error only is indicated. (Past failure can not be seen)

Note) Regarding light ON of engine check lamp

Diag. Sw OFF (user mode) : Check lamp turns ON when failure occurs.

Diag. Sw ON : 2 digit code is indicated by blinking of check lamp. ("No error" is indicated by continuous blinking as normal)

3. Indication of failure code : Failure code is indicated in sequence from smaller number of failure codes repeatedly.
The below shows example of diag. code indication.
(Upper ... Code 32 and code 21 are indicated. Lower ... normal case.)

10. ELECTRIC SYSTEM

3. Indication of diagnosis codes

- (1) For example, the following chart shows the case when the diagnosis codes 32 and 21 are displayed. The display method is based on the blinking intervals of the lamp. First, the first code makes the lamp light on the figure "3" at the 10's place for 0.5 seconds 3 times and lights on 2 times after 1.5 seconds. Next code display makes the lamp light on 2 + 1 times having 4.3 seconds intervals in the same way as the first code, and afterward this sequence will be repeated. Next code display makes the lamp light on 2 + 1 times having 4.3 seconds intervals in the same way as the first code, and afterward this sequence will be repeated.
- (2) Usually, the lamp does not light on or blink when the system has no abnormality. At this time, if the diagnosis indication connector is connected, the lamp repeats blinking with 0.3 seconds of light-on duration.

[Example] Display of diagnosis codes

example 1) When codes 32 and 21 are displayed

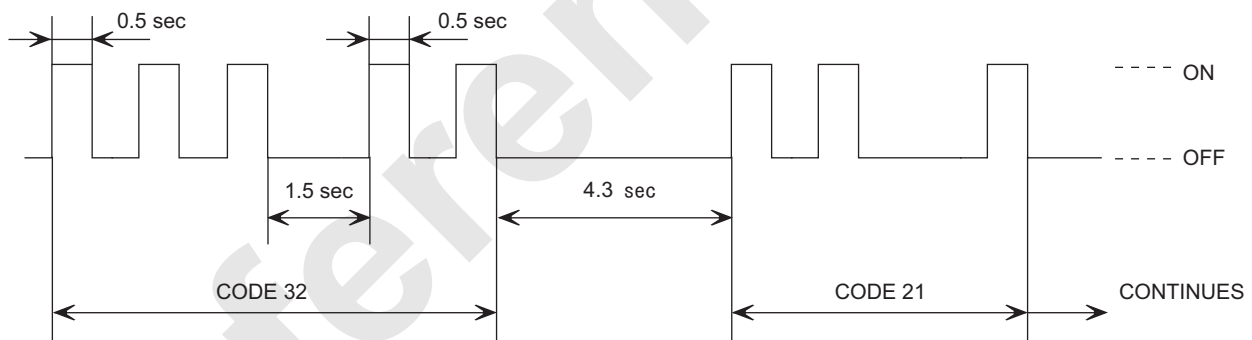

example 2) Normality displayed

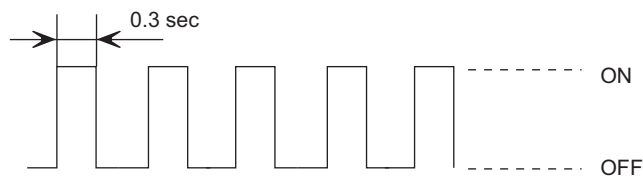

10.1.16 CHECKING OF DIAGNOSIS LAMP FUNCTION

The diagnosis lamp function is normal when the lamp is lit up with the following conditions.

[Requirements for checking lit-up diagnosis lamps]

- No any fault to be lit up the diagnosis lamp
- Diagnosis indication connector (CN-446) : Open
- Engine Key switch : ON position
- No Engine RPM signal : 0 mim⁻¹

Note

If the diagnosis lamp will not be lit up with the above conditions, inspect and repair the lamp or other relating parts.

Reference

10. ELECTRIC SYSTEM

10.1.17 ENGINE ECU

ECU TERMINAL NUMBER

Engine sub harness connector no.
Connector A : Respond connector : CN-614

1	2	3	
4	5	6	7
8	9	10	
11	12	13	14

Connector B: Respond connector :CN-615

1	2	3	4
5	6	7	8
9	10	11	12
13	14	15	16

Connector C: Respond connector :CN-635

1

Connector D: Respond connector :CN-616

1	2	3	4
5	6	7	8
9	10	11	12

Connector E: Respond connector :CN-638

1	2
3	4

Connector A			Connector B			Connector C			Connector D			Connector E		
Terminal NO	Ter. symbol	Content	Terminal NO	Ter. symbol	Content	Terminal NO	Ter. symbol	Content	Terminal NO	Ter. symbol	Content	Terminal NO	Ter. symbol	Content
1	VNTV EGRV +BF1 +BF2	VNT·EGR Power	1	-	-	1		Grow plug	1	THA+	AFM·intake air temp sensor signal	1	GRL	Grow lamp
2	VB1~4	ECU main power	2		ALT·L	2		-	2	AGD5	AFM·intake air temp sensor GND	2		-
3	ADG7	Work accel sensor GND	3	ST	Starter SW	3		-	3	AFVB	AFM power	3		-
4	NUSW CLSW	Neutral SW Clutch SW	4	PTO	Work accel sensor SW	4		-	4	AGD6	AFMGND	4		-
5	SSWS SWSS	Key SW Key SW-Spare	5	DPF	DPR LT	5		-	5	ADG9	Press. Diffrence GND	5		-
6	GRY1	Heater relay	6	DPSW	DPR SW	6		-	6	EXPS	Pressure difference signal	6		-
7	BATT	Battery	7		ALT·R	7		-	7	AVC5	Pressure difference sensor power	7		-
8	ASCS	Work accel sensor signal	8	MRL1 MRL2	ECU Main relay	8		-	8	AFSI	AFM Signal	8		-
9	-	-	9		-	9		-	9	ADG0	Exhaust air temp sensor 1 GND	9		-
10	IS0K	Daig connector signal	10	CANIH	CAN HIGH	10		-	10	ET3+	Exhaust air temp sensor 1 signal	10		-
11	OIL+	Hyd press. SW	11	CANIL	CAN LOW	11		-	11	ADG0	Exhaust air temp sensor 2 GND	11		-
12	VNTG EGRV CGD1 CGD2	VNT·EGR GND	12	STOP	Engine stop SW	12		-	12	ET4+	Exhaust air temp sensor 2 signal	12		-
13	PGD1 to 4	Power GND	13	ADG8	Accel sensor 2 GND	13		-	13		-	13		-
14	-	ALT·P	14	ACS2	Accel sensor 2 signal	14		-	14		-	14		-
15	-	-	15	ADG7	Accel sensor 1 GND	15		-	15		-	15		-
16	-	-	16	ACS1	Accel sensor 1 signal	16		-	16		-	16		-

10.2 LOAD SAFETY DEVICE

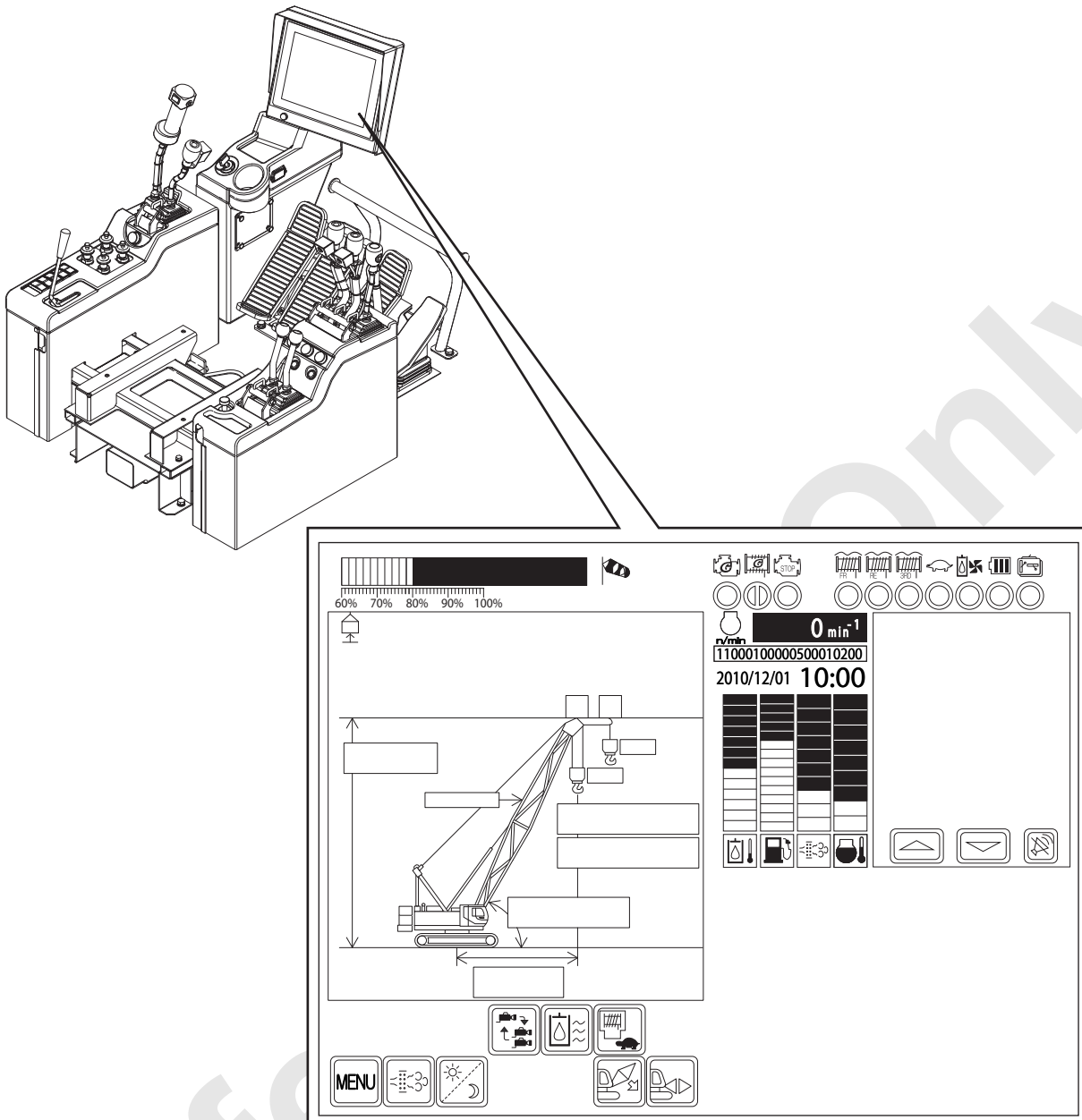

CAUTION

All values in the figure are for reference only.

10. ELECTRIC SYSTEM

10.2.2 SYSTEM DAIGRAM

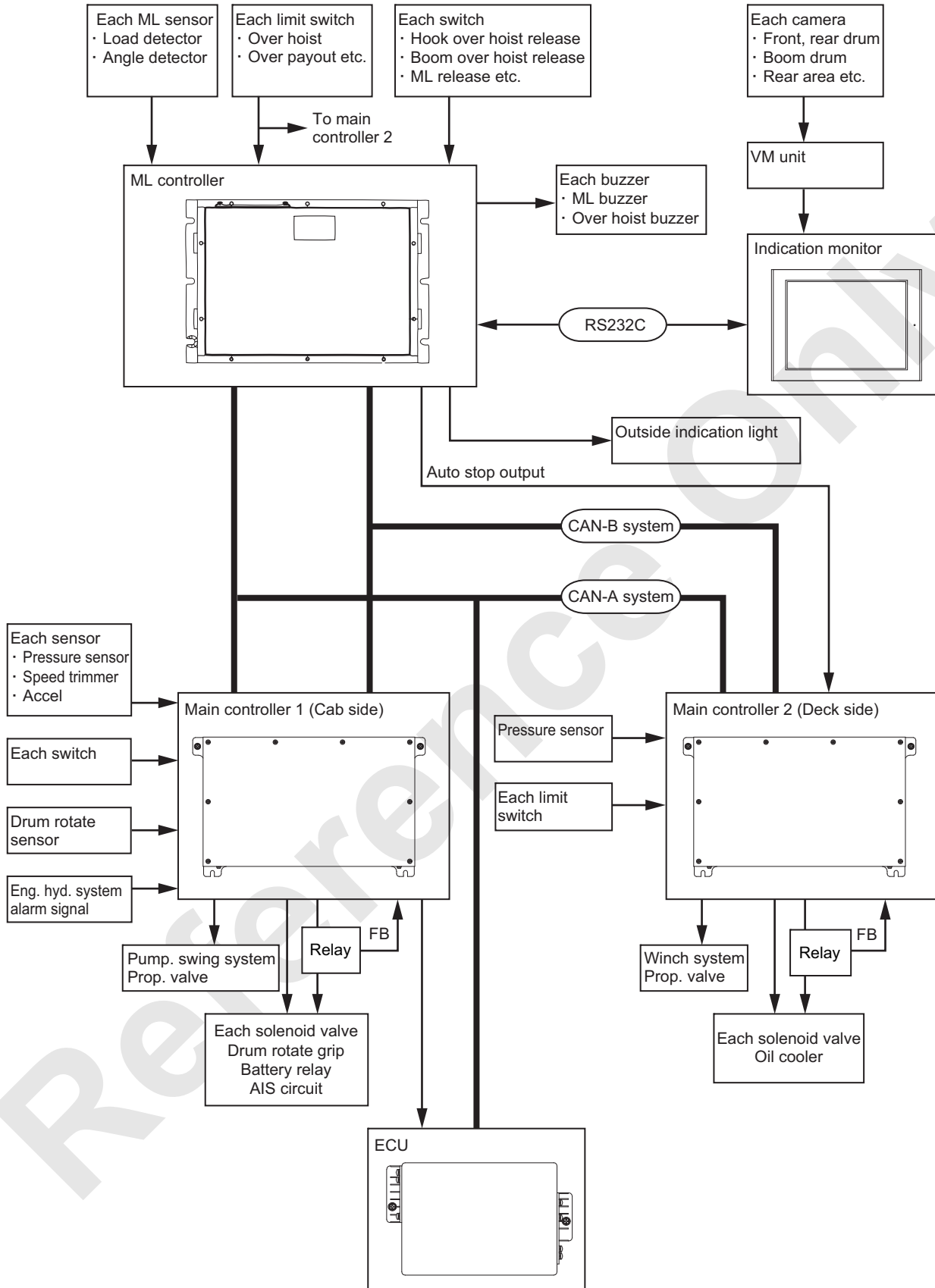

10.2.3 MONITOR INDICATION

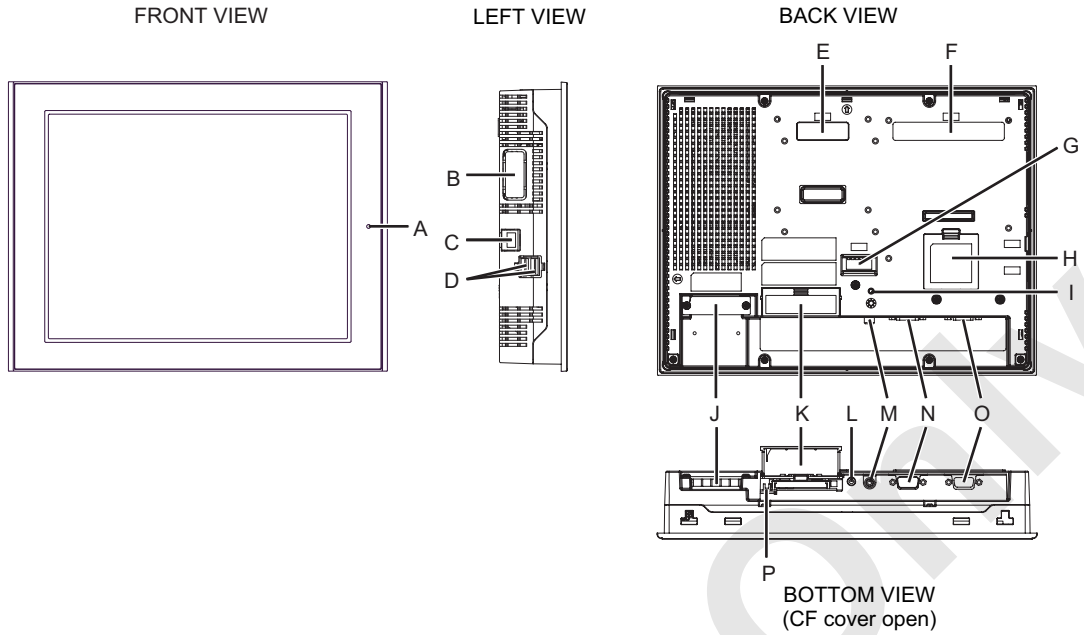

Name		Explanation				
A	STATUS LED	Color	Indication	Operation mode (pictorial)	Logic motion mode (when logic is effective)	
		Green	ON	Off line	-	
			Flashing	Running	RUN	STOP
		Red	ON	At power ON		
			Flashing	Running	Major abnormal	
		Orange	ON	Backlight bulb is blown or main machinery failure *1		
Flashing	Software is being started.					
* 1. Backlight replacement needs returning to manufacturer.						
B	Extended unit interface (EXT)	For installation of extended unit (Transmission function) * not used				
C	Ethernet interface (LAN)	10BASE-T / 100BASE-TX RJ-45 type modular jack connector (8 pole) * not used				
D	USB Host interface (USB)	2 port. USB 1.1 correspond Type A Voltage DC5V ± 5%, Output current : 500mA (Max) Max transmission distance 5m * not used				
E	Extended unit interface 1 *1	For installation of extended unit (Transmission function) * not used				
F	VM unit interface 1 *1	This is to connect VM unit when camera is to be connected.				

10. ELECTRIC SYSTEM

	Name	Explanation
G	Aux. input/output / Voice output interface (AUX)	Outside reset, alarm output, buzzer output, sound output. * not used
H	Extended memory interface	* not used
I	CF card access	Green light is ON when CF card is inserted and cover is closed or CF card is being accessed. <MEMO> · Do not insert or take out CF card when LED lamp is ON Otherwise data in the CF card may be destroyed.
J	Power supply connector	DC model : Connector (socket) type
K	CF card cover	-
L	Audio input interface (L-IN / MIC)	This is to connect microphone. Minijack connector (φ 3.5mm) * not used
M	Video input interface (V-IN)	NTSC (59.9Hz) / PAL (50Hz) type correspond RCA connector (75Ω) * not used
N	Serial interface (COM1)	D-SUB9 pin plug type, RS232C. This is used for transmission to ML
O	Serial interface (COM2)	D-SUB9 pin socket type. Correspond to RS422 / RS485. * not used
P	Dip Switch	In the CF card cover. * not used

GENERAL SPECIFICATION

- ELECTRICAL SPECIFICATION

		DC model
Power supply	Rated voltage	DC24V
	Voltage range	DC19.2 to 28.8V
	Allowable instant power outage time	10ms or less
	Power consumption	DC24V 2.08A or less (TYP 1.30A)
	Inrush current	30A or less
Dielectric strength		AC1000V 20mA 1 minute (between charging terminal and FG terminal)
Insulating resistance		DC500V, more than 10MΩ (between charging terminal and FG terminal)

- Environmental specification

Physical environment	Atmospheric temp for use	0 to 50°C (32 to 122°F) *1
	Atmospheric temp for storing	-20 to +60°C (-4 to 140°F)
	Atmospheric humidity for use	10 to 90%RH (No condensation. Wet bulb temp 39°C (102°F) or lower.
	Atmospheric humidity for storing	10 to 90%RH (No condensation. Wet bulb temp 39°C (102°F) or lower.
	Dust	0.1mg/m ³ or less (No conductive dust)
	Contamination	Contamination degree 2

*1 As for STN color LCD equipped model, long time use under ambient temperature higher than 40 degrees C may cause indication quality lowering such as contrast.

- Installation specification

Condition	Ground	Functional grounding : D type ground (for both SG-FG)
	Construction *1	Protection : IP65f equivalent NEMA #250 TYPE 4X/13 (Front surface at panel built in.) Shape : Built in type Installation method : Panel built in.
	Cooling type	Natural cooling

*1 Protective construction of the front area when this unit is installed in the panel. Adaptability has been checked under these conditions but it does not necessary guarantee use under all environmental conditions. Even the oil specified in the test may cause oil ingress due to sheet peeling off of the front area if this unit is exposed in such oil in sprayed condition for long time or exposed in extremely low viscosity machine oil. In such case, some other countermeasure may become necessary. Use of non specified oil may cause same oil ingress or plastic deterioration. Check environmental condition in advance before use. Drip proof packing used for long time or reused drip proof packing once installed on the panel has dirt or flaw and may not be good for protection. Periodical replacement of drip proof packing is recommended.

OUTER INTERFACE

- COM1 (Used for transmission to ML)

Recommended connector in cable side	XM2D-0901 Omron
Recommended jack screw	XM2Z-0073 Omron
Recommended cover	XM2S-0913 Omron
Caulking fix fitting	#4-40 (UNC)

Pin No.	RS232C	
	Signal	Content
1	CD	Carrier detect
2	RD (RXD)	Received data
3	SD (TXD)	Transmitted data
4	ER (DSR)	Data terminal ready
5	SG	Signal ground
6	DR (DSR)	Data set ready
7	RS (RTS)	Transmission request
8	CS (CTS)	Transmission permit
9	CI (RI) / (VCC)	Indication +5V \pm 5% output 0.25A *1

10. ELECTRIC SYSTEM

• INSTALLATION PROCEDURE

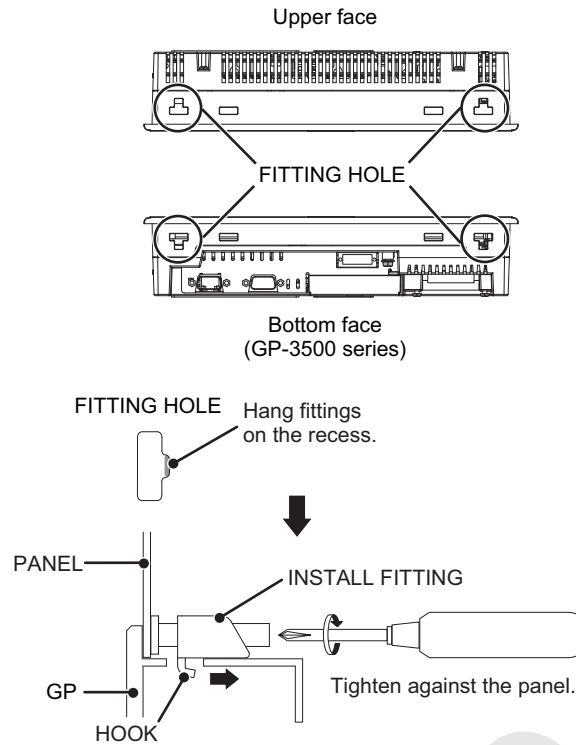

CAUTION

Overtightening the screws may damage the GP.
Proper tightening torque for drip proof effect is 0.5 N-m.

POWER SUPPLY WIRING

WARNING

Electric shock may be caused. Ensure to connect under power supply is disconnected.
Do not supply other than specified voltage.
Otherwise main body may be damaged.
Ensure to connect FG terminal to earth.
Otherwise electric shock may be caused in case of failure.
Failure to observe these precautions may result in serious injuries or loss of life.

- Power cable specification

Use copper core wire.

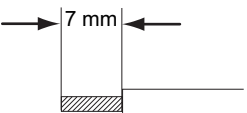
Size of power cable	0.75 to 2.5mm ² (18 - 12 AWG)
Core wire	Solid or strand wire *1
Core wire length	

*1 If strand wire is used, ensure that the core wire is properly stranded. Otherwise shortening may occur by strand touching the adjacent terminal.

- Power supply connector (plug) specification

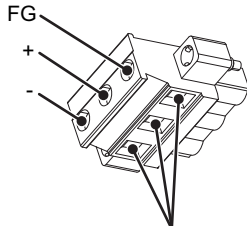
 POWER CABLE CONNECTING AREA	+	24V
	-	0V
	FG	Ground terminal connected to GP body. * Not used

Note

Power supply connector is DIGITAL CA5-DCCNL-01 or PHOENIX-CONTACT GMVSTBW2, 5/3-STF-7, 62.

Use wiring material as shown below. These are all product of PHOENIX- CONTACT.

Recommended screw driver	SZF 1-0.6 X 3.5 (1204517)
Recommended terminal	AI 0.75-8GY (3200519)
	AI 1-8RD (3200030)
	AI 1.5-8BK (3200043)
Recommended crimping tool for terminal	AI 2.5-8BU (3200522)
	CRIMPFOX ZA 3 (1201882)

10. ELECTRIC SYSTEM

- Procedure of power cable connection
 1. Ensure that the power is disconnected.
 2. Take out the power supply connector (plug) from the main body.
 3. Loosen the 3 screws in the center of power supply connector.
 4. Peel off the sheath of the power supply cable and twist the strand wire and insert into rod terminal and crimp.
Install it to the connecting points.
 5. Secure them with screws.

CAUTION

When tightening the terminal screw, use flat head screw driver (Size 0.6 X 3.5).

Tightening torque is 0.5 to 0.6 N-m.

Do not solder on cable connection point.

Otherwise extreme heat may cause failure of fire.

6. Install the power supply cable to GP and secure it to GP body with left and right power supply connector securing screws.

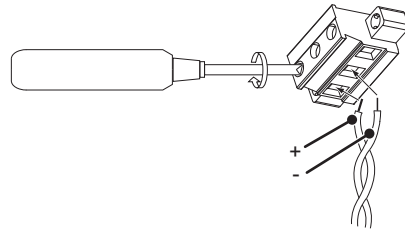

10.2.4 DETAIL OF MOMENT LIMITER CONNECTOR

1. Outside view and connector layout

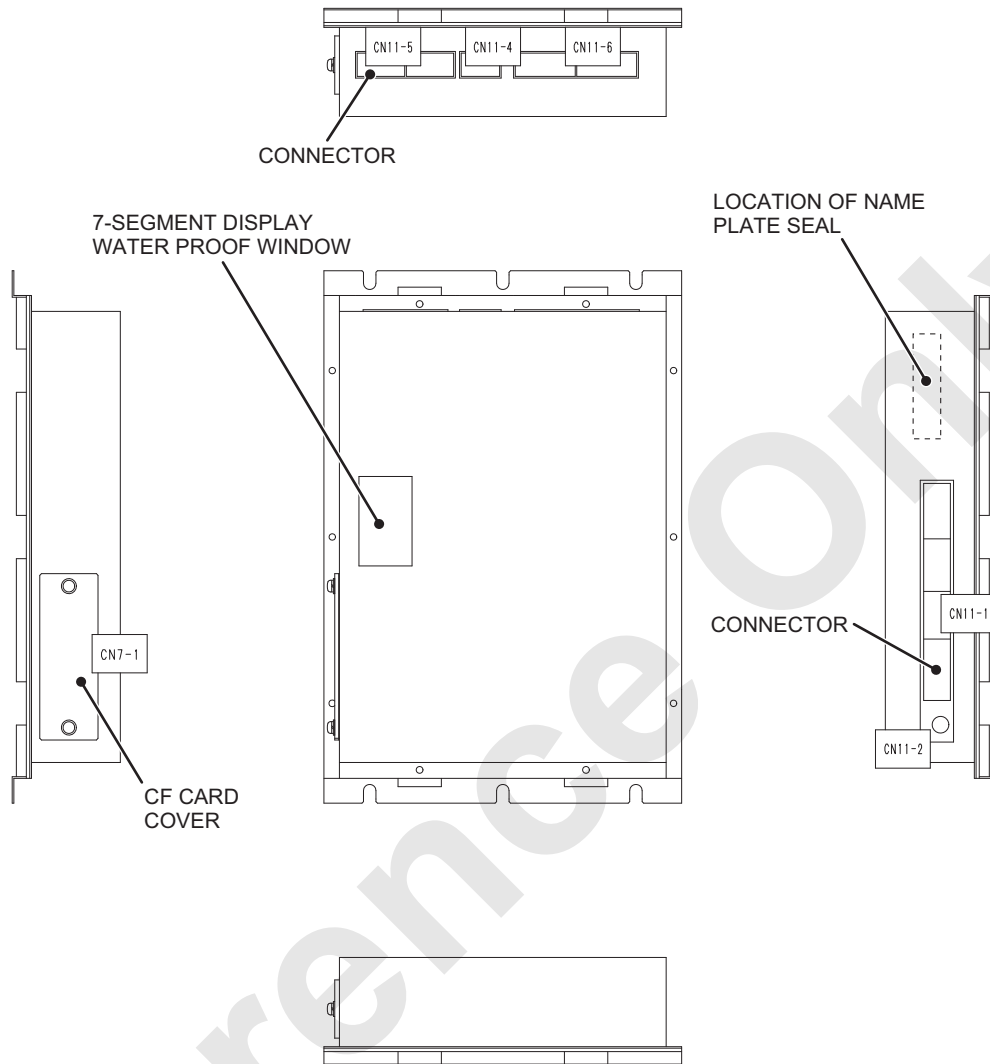

- CF card contains the adjusted data as backup. When replacing the ML controller, ensure to re-insert the original CF card and copy the backup data to the controller.

10. ELECTRIC SYSTEM

2. ML controller connector pin layout (View from main machinery harness)

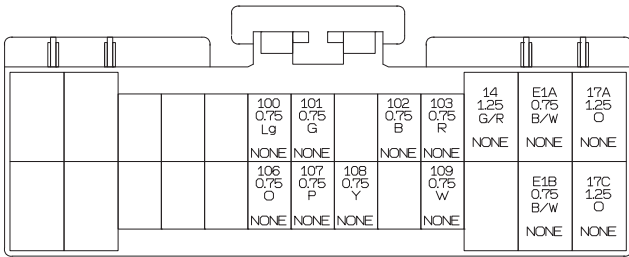

CN-11-1AF

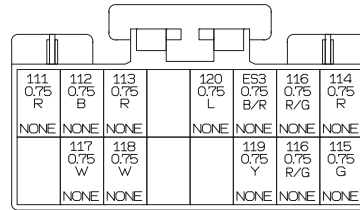

CN-11-1BF

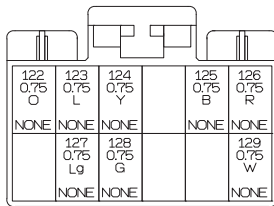

CN-11-1CF

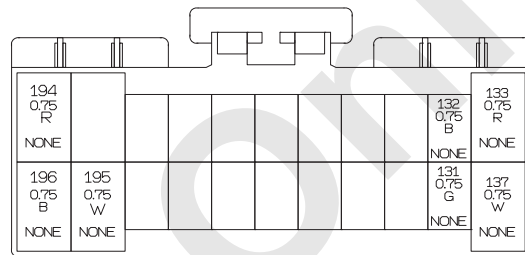

CN-11-1DF

Connector No.	Pin No.	Name	Wire No.	Wire color	Specification
CN-11-1A	1	Control power (+)	17A	O	Main power (IG power +)
	6	Control power (+)	17C	O	Main power (IG power +)
	2	Control power (-)	E1A	B/W	Main power (IG power GND)
	7	Control power (-)	E1B	B/W	Main power (IG power GND)
	3	Backup power (+)	14	G/R	Sub power (+B power +)
	8	Backup power (GND)	E	BW	Sub power (+B power GND)
	17	Load detector (for crane) power (+)	103	R	12V load detecting power -1 (+)
	25	Load detector (for crane) signal	109	W	12V load detecting signal -1 (0 to 6.2V)
	18	Load detector (for crane) power (-)	102	B	12V load detector power (GND)
	26				12V load detector signal -2 (0 to 6.2V)
	19				12V load detector power -2 (+)
	27	Load detector (for jib) power (+) (Not used)	108	Y	12V load detector power -3 (+)
	20	Load detector (for jib) signal (Not used)	101	G	12V load detecting signal -3 (0 to 6.2V)
	28	Load detector (for jib) power (-) (Not used)	107	P	12V load detector power (GND)
	21				12V load detecting signal -4 (0 to 6.2V)
	29				12V load detector power -4 (+)
	22				12V load detector power -5 (+)
	30				12V load detecting signal -5 (0 to 6.2V)
	23				12V load detector power (GND)
	31				12V load detecting signal -6 (0 to 6.2V)
	24				12V load detector power -6 (+)
	32				12V load detector power -7 (+)
	4				12V load detecting signal -7 (0 to 6.2V)
9				12V load detector power (GND)	
5				12V load detecting signal -7 (0 to 6.2V)	
10				12V load detector power -8 (+)	

10. ELECTRIC SYSTEM

Connector No.	Pin No.	Name	Wire No.	Wire color	Specification
CN-11-1B	33	Inter main controller transmission 1 (H)	114	R	CAN0 H
	41	Inter main controller transmission 1 (L)	115	G	CAN0 L
	34	Inter main controller transmission 1 (H end)	116	R/G	CAN0 H end
	42	Inter main controller transmission 1 (L end)	116	R/G	CAN0 L end
	35	Shield earth	ES3	B/R	Shield earth signal ground
	43	Inter main controller transmission 2 (H)	119	Y	CAN1 H
	36	Inter main controller transmission 2 (L)	120	L	CAN1 L
	44				CAN1 H end
	37				CAN1 L end
	45				Shield earth signal ground
	38	Boom angle detector power (+)	113	R	12V ML system sensor power 1-1 (+)
	46	Boom angle detector signal	118	W	12V ML system sensor signal 1-1 (0 to 12V)
	39	Boom angle detector power (GND)	112	B	12V ML system sensor power 1 (GND)
	47				12V ML system sensor signal 1-2 (0 to 12V)
	40				12V ML system sensor power 1-2 (+)
48	vacant			vacant	
CN-11-1C	49	Crane mast angle detector power (+) (Not used)	126	R	12V ML system sensor power 1-3 (+)
	55	Crane mast angle detector signal (Not used)	129	W	12V ML system sensor power 1-3 (0 to 12V)
	50	Crane mast angle detector power (GND) (Not used)	125	B	12V ML system sensor power 1 (GND)
	56				12V ML system sensor signal 1-4 (0 to 12V)
	51				12V ML system sensor signal 1-4 (+)
	57	vacant			vacant
	52	Jib angle detector power (+)	124	Y	12V ML system sensor power 2-1 (+)
	58	Jib angle detector signal (OPT)	128	G	12V ML system sensor signal 2-1 (0 to 12V)
	53	Jib angle detector power (GND)	123	L	12V ML system sensor power 2 (GND)
	59				12V ML system sensor signal 2-2 (0 to 12V)
	54				12V ML system sensor power 2-2 (+)
	60	vacant			vacant

Connector No.	Pin No.	Name	Wire No.	Wire color	Specification
CN-11-1D	11	Swing angle detector power (+)	133	R	12V ML system sensor power 2-3 (+)
	14	Swing angle detector (A) signal	137	W	12V ML system sensor signal 2-3 (0 to 12V)
	61	Swing angle detector power (-)	132	B	12V ML system sensor power 2 (GND)
	69	Swing angle detector (B) signal	131	G	12V ML system sensor signal 2-4 (0 to 12V)
	62				12V ML system sensor power 2-4 (+)
	70				24V load detector power 2-4 (+)
	63				24V load detector signal -1 (0 to 12.5V)
	71				24V load detector power (GND)
	64				24V load detector signal -2 (0 to 12.5V)
	72				24V load detector power -2 (+)
	65				24V load detector power -3 (+)
	73				24V load detector signal -3 (0 to 12.5V)
	66				24V load detector power (GND)
	74				24V load detector signal -4 (0 to 12.5V)
	67				24V load detector signal -4 (0 to 12.5V)
	75	vacant			vacant
	68	vacant			vacant
	76	vacant			vacant
	12				RS232C (+)
	15	Inter monitor transmission (TXD)	195	W	RS232C (TXD)
13	Inter monitor transmission (RXD)	194	R	RS232C (RXD)	
16	Inter monitor transmission (GND)	196	B	RS232C (GND)	

10. ELECTRIC SYSTEM

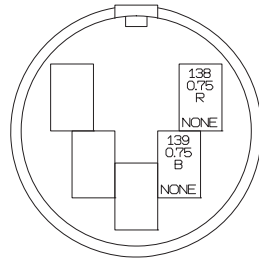

CN-11-2M

Connector No.	Pin No.	Name	Wire No.	Wire color	Specification
CN-11-2	1				Composite signal (+)
	2	vacant			vacant
	3	Camera power (+)	138	R	12V LCD monitor power (+)
	4				Composite signal (GND)
	5	Camera power (GND)	139	B	12V LCD monitor power (+GND)

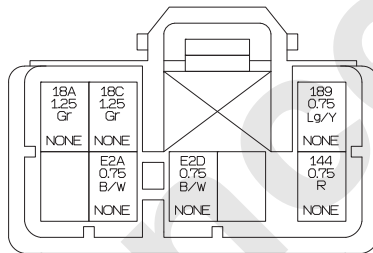

CN-11-4F

Connector No.	Pin No.	Name	Wire No.	Wire color	Specification
CN-11-4	1	Output power (+)	18A	Gr	Extended 24V power (+)
	4				Extended 25V power (+)
	2	Output power (+)	18A	Gr	Extended 26V power (+)
	5	Output power (-)	E2A	B/W	Extended 24V power (GND)
	6	Output power (-)	E2D	B/W	Extended 25V power (GND)
	7				Extended 26V power (GND)
	3	Voice alarm output 4	189	Lg/Y	Ground output (0.1A)
	8	Outside indication light (Red)	144	R	Ground output (0.2A)

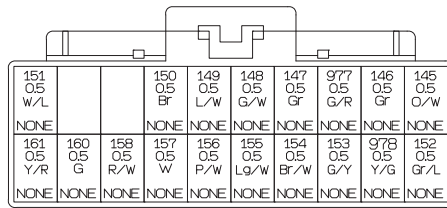

CN-11-5AF

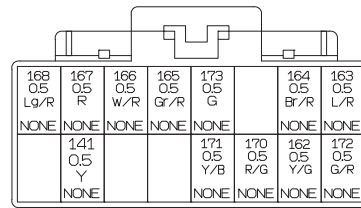

CN-11-5BF

Connector No.	Pin No.	Name	Wire No.	Wire color	Specification
CN-11-5A	1	Hook over hoist LS1	145	O/W	24V input
	2	Hook over hoist LS2	146	Gr	24V input
	3	Gantry hoist detect LS (Not used)	977	G/R	24V input
	4	Boom backstop no.2 LS	147	Gr	24V input
	5	Crane boom over hoist LS	148	G/W	24V input
	6	Boom backstop no.1 LS	149	L/W	24V input
	7	Jib over hoist LS	150	Br	24V input
	8	Crane mast over lower LS (Not used)			24V input
	9	HL mast over hoist LS (Not used)			24V input
	10	Strut over hoist LS (Not used)	151	W/L	24V input
	11	Strut over lower LS (Not used)	152	Gr/L	24V input
	12	Mast cylinder position detect LS (Not used)	978	Y/G	24V input
	13	TW jib bending prevent LS (Not used)	153	G/Y	24V input
	14	Latch (engage) LS (Not used)	154	Br/W	24V input
	15	Latch (disengage) LS (Not used)	155	Lg/W	24V input
	16	Over payout prevent LS (front)	156	P/W	24V input
	17	Over payout prevent LS (rear)	157	W	24V input
	18	Over payout prevent LS (third)	158	R/W	24V input
	19	Main controller 1 bypass SW	160	G	24V input
	20	Main controller 2 bypass SW	161	Y/R	24V input

10. ELECTRIC SYSTEM

Connector No.	Pin No.	Name	Wire No.	Wire color	Specification
CN-11-5B	21	Drum select SW (rear)	163	L/R	24V input
	22	Drum select SW (front)	164	Br/R	24V input
	23				24V input
	24	Download start signal	173	G	24V input
	25	Master key SW	165	Gr/R	24V input
	26	Hook over hoist release SW	166	W/R	24V input
	27	Boom/Jib over hoist release SW	167	R	24V input
	28	Moment limiter release SW	168	Lg/R	24V input
	29	CEN spec. distinct signal	172	G/R	Ground input (330Ω)
	30	Simultaneous control permit signal	162	Y/G	Ground input (330Ω)
	31	Adjustment permit signal	170	R/G	Ground input (4.7kΩ)
	32	Program rewrite permit signal	171	Y/B	Ground input (4.7kΩ)
	33	vacant			vacant
	34	vacant			vacant
	35	Wind speed sensor	141	Y	Pulse input (+)
	36				Pulse input (-)

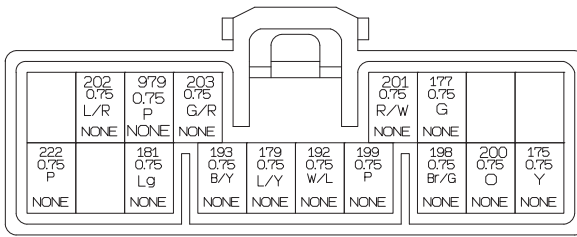

CN-11-6AF

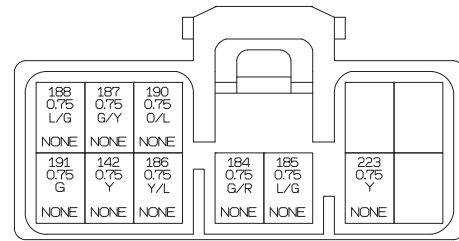

CN-11-6BF

Connector No.	Pin No.	Name	Wire No.	Wire color	Specification
CN-11-6A	13				24V Output
	30	Front drum raise stop	175	Y	24V Output
	12				24V Output
	29	Front drum lower stop	200	O	24V Output
	11	Rear drum raise stop	177	G	24V Output
	28	Mode select (luffing jib)	198	Br/G	24V Output
	10	Rear drum lower stop	201	R/W	24V Output
	27	Mode select (mast)	199	P	24V Output
	26	Mode select (assy/disassy)	192	W/L	24V Output
	25	Third drum raise stop	179	L/Y	24V Output
	24	Mode select (self removal)	193	B/Y	24V Output
	9	Third drum lower stop	203	G/R	24V Output
	8	Outside indication light (buzzer)	979	P	24V Output
	23	Boom drum raise stop	181	Lg	24V Output
	7	Boom drum lower stop	202	L/R	24V Output
	22				24V Output
6				24V Output	
21	Mast bending prevent signal	222	P	24V Output	
CN-11-6B	5				24V Output
	20				24V Output
	4				24V Output
	19	Operator authenticate signal	223	Y	24V Output
	18	Overload buzzer	185	L/G	24V Output
	17	Over hoist buzzer	184	G/R	24V Output
	3	Voice alarm output 5	190	O/L	Ground output (0.1A)
	16	Voice alarm output 1	186	Y/L	Ground output (0.1A)
	2	Voice alarm output 2	187	G/Y	Ground output (0.1A)
	15	Outside indication light (yellow)	142	Y	Ground output (0.1A)
	1	Voice alarm output 3	188	L/G	Ground output (0.1A)
	14	Outside indication light (green)	191	G	Ground output (0.1A)

10. ELECTRIC SYSTEM

3. System block diagram

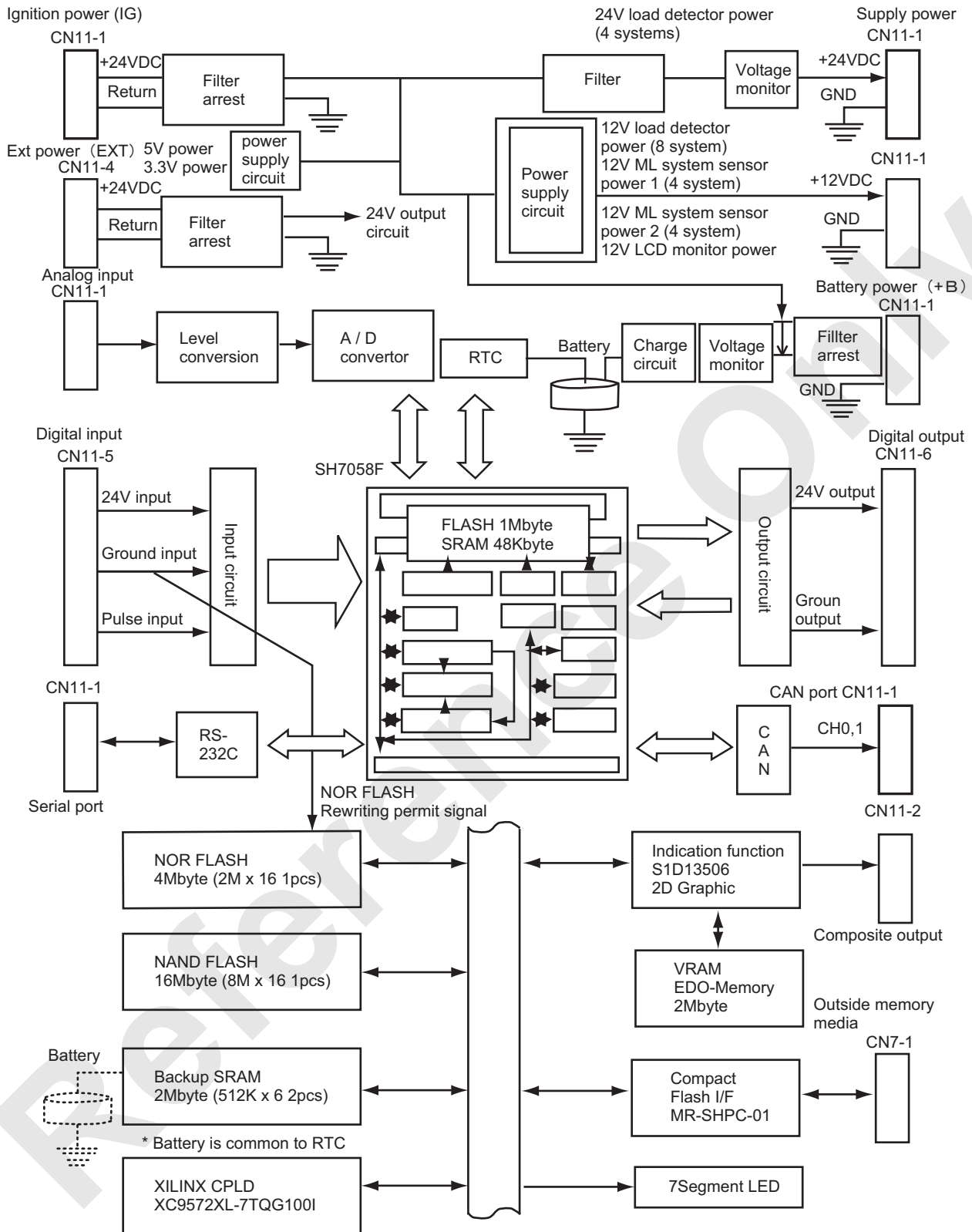

4. ML INPUT/OUTPUT

(1) ANALOGUE INPUT [A]

No.	Name	Variation	Input Voltage	Remarks
1	Crane boom load detector	0t to rated t	1 to 5V	CN11-1-25
2	Spare	↑	↑	CN11-1-26
3	Jib load detector	↑	↑	CN11-1-20
4	Spare	↑	↑	CN11-1-21
5	Spare	↑	↑	CN11-1-30
6	Spare	↑	↑	CN11-1-31
7	Spare	↑	↑	CN11-1-4
8	Spare	↑	↑	CN11-1-5
9	Boom base angle detector	-150 to +150°	0.4 to 11.6V	CN11-1-46
10	Spare	↑	↑	CN11-1-47
11	Crane mast angle detector	↑	↑	CN11-1-55
12	Spare	↑	↑	CN11-1-56
13	Jib base angle detector	↑	↑	CN11-1-58
14	Spare	↑	↑	CN11-1-59
15	Swing angle detector A	0° to 180°	0 to 12V	CN11-1-14
16	Swing angle detector B	↑	0 to 12V	CN11-1-69
17	Spare		0 to 12.5V	CN11-63
18	Spare		0 to 12.5V	CN11-64
19	Spare		0 to 12.5V	CN11-73
20	Spare		0 to 12.5V	CN11-74
21				
22				
23				

(2) PULSE INPUT (BREAK IN) [E]

No.	Name	Condition	Signal level	Remarks
1	Anemometer		GND/OPEN	CN11-5-35

10. ELECTRIC SYSTEM

(3) DIGITAL INPUT [B]

No.	Name	Condition	Signal level	Remarks
1	Hook over hoist LS1	Normal / Over	+24V/OPEN	CN11-5-1
2	Hook over hoist LS2	Normal / Over	+24V/OPEN	CN11-5-2
3	Gantry raise detect LS	Not detect / Detect	+24V/OPEN	CN11-5-3
4	Boom B/S No.2 LS	Normal / Over	+24V/OPEN	CN11-5-4
5	Crane boom over hoist LS	Normal / Over	+24V/OPEN	CN11-5-5
6	Boom B/S No.1 LS	Normal / Over	+24V/OPEN	CN11-5-6
7	Jib over hoist LS	Normal / Over	+24V/OPEN	CN11-5-7
8	Crane mast over lower LS	Normal / Over	+24V/OPEN	CN11-5-8
9	Spare		+24V/OPEN	CN11-5-9
10	Spare		+24V/OPEN	CN11-5-10
11	Spare		+24V/OPEN	CN11-5-11
12	Mast cylinder LS	Not detect / Detect	+24V/OPEN	CN11-5-12
13	TW jib bending prevent LS	Ground / Normal	+24V/OPEN	CN11-5-13
14	Latch (engage) LS	Engage / Normal	+24V/OPEN	CN11-5-14
15	Latch (disengage) LS	Disengage / Normal	+24V/OPEN	CN11-5-15
16	Over payout prevent (Raise No.1)	Normal / Over	+24V/OPEN	CN11-5-16
17	Over payout prevent (Raise No.2)	Normal / Over	+24V/OPEN	CN11-5-17
18	Over payout prevent (Raise No.3)	Normal / Over	+24V/OPEN	CN11-5-18
19	MC1 bypass SW	Bypass / Normal	+24V/OPEN	CN11-5-19
20	MC2 bypass SW	Bypass / Normal	+24V/OPEN	CN11-5-20
21	Drum select (raise 2) CEN	Select / Not select	+24V/OPEN	CN11-5-21
22	Drum select (raise 1) CEN	Select / Not select	+24V/OPEN	CN11-5-22
23			+24V/OPEN	CN11-5-23
24	DL start SW	Start / Normal	+24V/OPEN	CN11-5-24
25	Master key	Release / Normal	+24V/OPEN	CN11-5-25
26	Hook over hoist release	Release / Normal	+24V/OPEN	CN11-5-26
27	Boom over hoist release	Release / Normal	+24V/OPEN	CN11-5-27
28	ML release	Release / Normal	+24V/OPEN	CN11-5-28
29	CEN spec. recognize signal	CEN / Normal	GND/OPEN	CN11-5-29
30	Simultaneous operate permit	Permit & CEN / Normal	GND/OPEN	CN11-5-30
31	For adjusting	Adjusting / Normal	GND/OPEN	CN11-5-31
32	For program rewriting	Rewriting / Normal	GND/OPEN	CN11-5-32

(4) ANALOGUE OUTPUT [H]

No.	Name	Condition	Signal level	Remarks
1				
2				

(5) DIGITAL OUTPUT [C]

No.	Name	Condition	Signal level	Remarks
1	Front drum raise stop	Actuate / Normal	+24V/OPEN	CN11-6-30
2	Front drum lower stop	Actuate / Normal	+24V/OPEN	CN11-6-29
3	Rear drum raise stop	Actuate / Normal	+24V/OPEN	CN11-6-11
4	Rear drum lower stop	Actuate / Normal	+24V/OPEN	CN11-6-10
5	Third (jib) drum raise stop	Actuate / Normal	+24V/OPEN	CN11-6-25
6	Third (jib) drum lower stop	Actuate / Normal	+24V/OPEN	CN11-6-9
7	Boom drum raise stop	Actuate / Normal	+24V/OPEN	CN11-6-23
8	Boom drum lower stop	Actuate / Normal	+24V/OPEN	CN11-6-7
9	Spare	Actuate / Normal	+24V/OPEN	CN11-6-6
10	Spare	Actuate / Normal	+24V/OPEN	CN11-6-20
11	Spare	Actuate / Normal	+24V/OPEN	CN11-6-13
12	Spare	Actuate / Normal	+24V/OPEN	CN11-6-12
13	Mode select (jib model)	Jib model / Except jib model	+24V/OPEN	CN11-6-28
14	Mode select (mast model)	Mast mode / Except mast model	+24V/OPEN	CN11-6-27
15	Mode select (assy,disassy)	Assy disassy / Except assy,disassy	+24V/OPEN	CN11-6-26
16	Mode select (self removal)	Self removal / Except self removal	+24V/OPEN	CN11-6-24
17	Outer indication light buzzer (red)	Actuate / Normal	+24V/OPEN	CN11-6-8
18			+24V/OPEN	CN11-6-22
19	Mast bending prevent	Actuate / Normal	+24V/OPEN	CN11-6-21
20			+24V/OPEN	CN11-6-5
21	Operator recognize signal	Actuate / Normal	+24V/OPEN	CN11-6-19
22			+24V/OPEN	CN11-6-4
23	Over hoist buzzer	Actuate / Normal	+24V/OPEN	CN11-6-17
24	Over load buzzer	Actuate / Normal	+24V/OPEN	CN11-6-18
25	Voice alarm 1	Actuate / Normal	GND/OPEN	CN11-6-16
26	Voice alarm 2	Actuate / Normal	GND/OPEN	CN11-6-2
27	Voice alarm 3	Actuate / Normal	GND/OPEN	CN11-6-1
28	Voice alarm 4	Actuate / Normal	GND/OPEN	CN11-4-3
29	Voice alarm 5	Actuate / Normal	GND/OPEN	CN11-6-3
30	Outer indication light (green)	On / Off	GND/OPEN	CN11-6-14
31	Outer indication light (yellow)	On / Off	GND/OPEN	CN11-6-15
32	Outer indication light (red)	On / Off	GND/OPEN	CN11-4-8

10. ELECTRIC SYSTEM

10.2.5 SHIFTING TO MAINTENANCE SCREEN

1. Push the [MENU] icon in the main screen.
2. Push [A] switch.

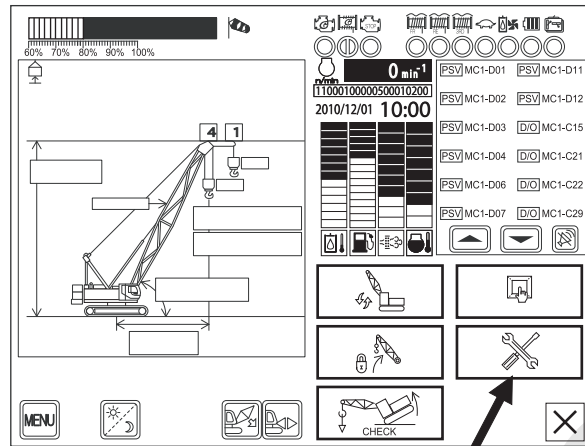

A

3. Input the password (8 digits) with the keyboard.
* In case of using capital letter, push CAPS switch.

CLR : All clear

DEL : One letter clear

BS : One letter clear and back

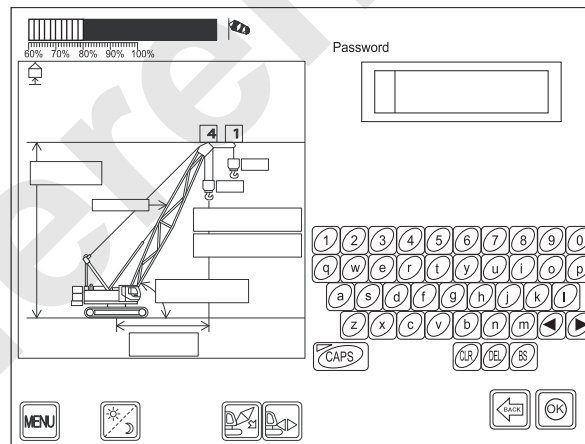

4. Push [OK] switch.

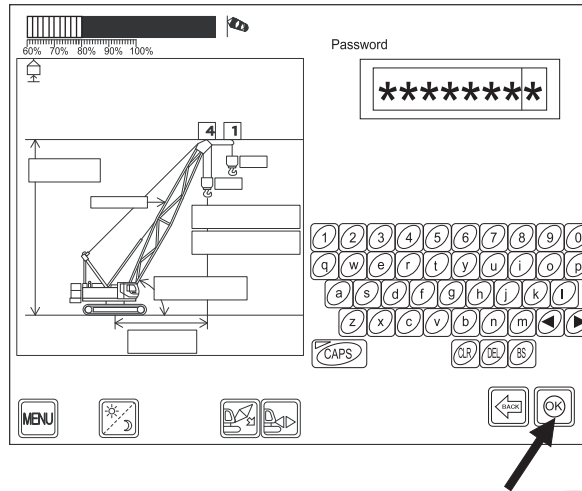

5. If password is correct, the maintenance menu becomes indicated.

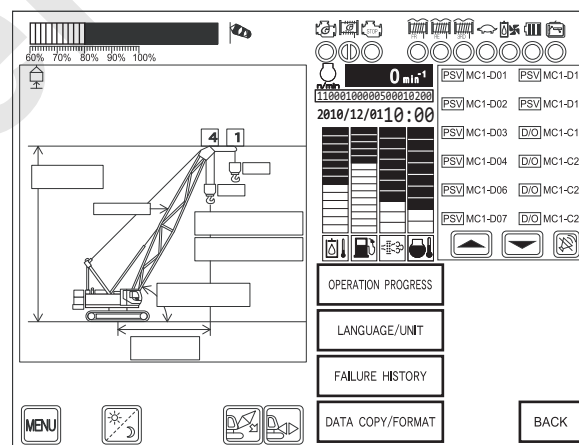
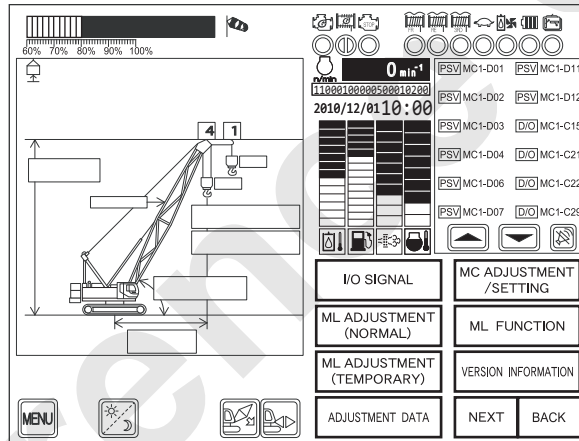

6. If password is not correct, password area blinks three times and then screen returns to 3. screen. Check the password and input again.

10. ELECTRIC SYSTEM

10.2.6 INPUT, OUTPUT SIGNAL

This screen can check input signal condition of various sensors or switches or output signal condition of solenoid valves, relays and proportional valves.

1. Push [I/O SIGNAL] in the maintenance menu.

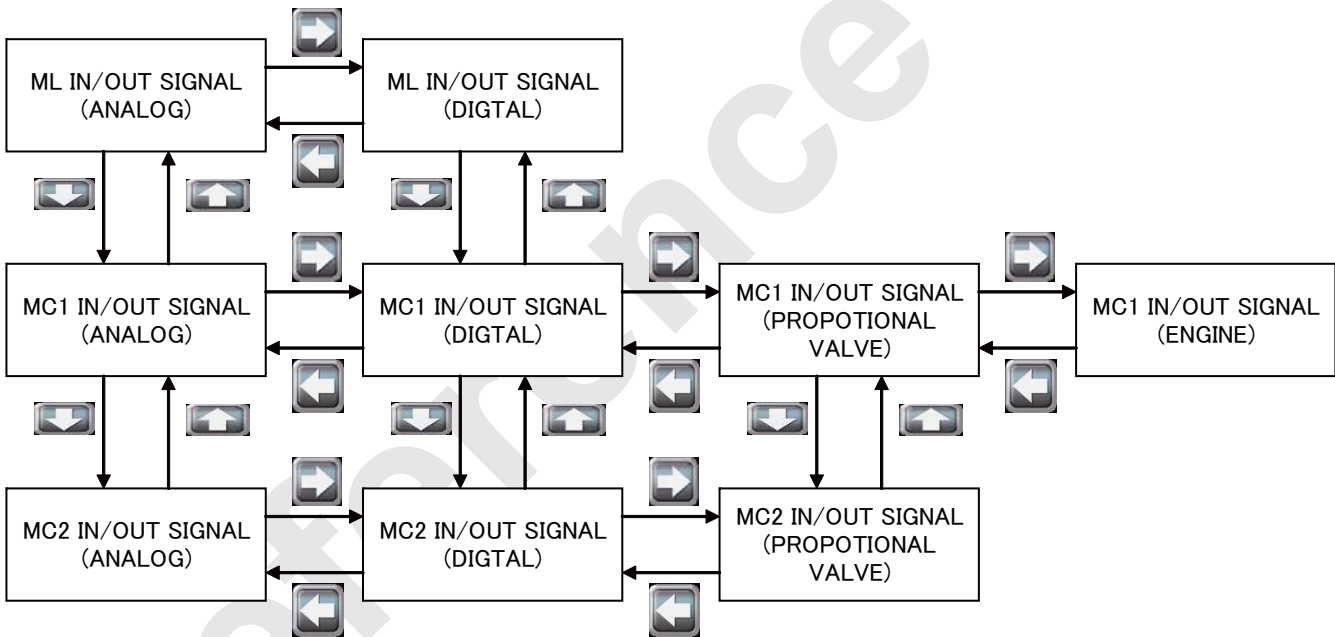
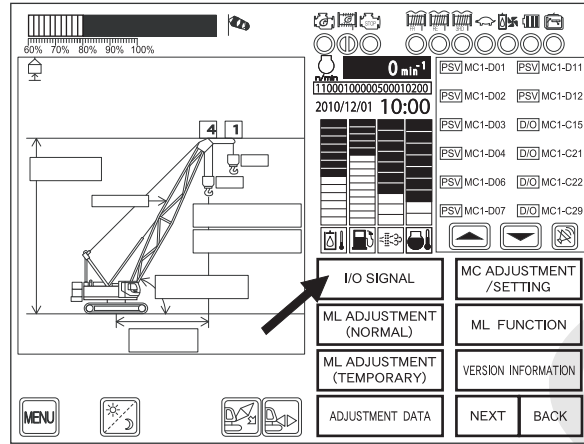

(1) INPUT, OUTPUT CHECK OF ML
(MOMENT LIMITER)

(A) Select [ML SCREEN] in the menu.

The first screen indicates condition of analog signal of the load detector, angle detector.

Unit of indicating figure is V (volt).

Refer to P.10-217 for connection and signal level.

0 V is indicated on non connected point.

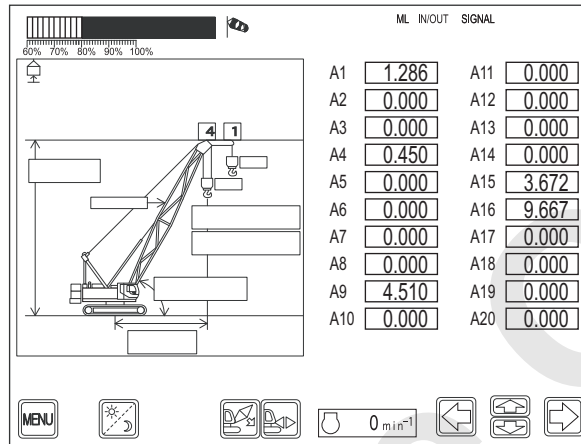

(B) By pushing [NEXT], digital input and digital output become indicated.

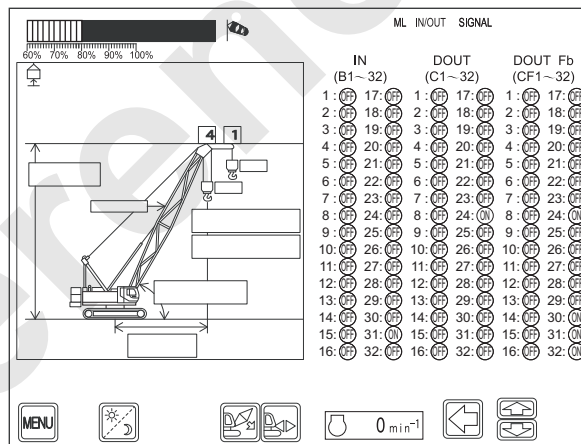

10. ELECTRIC SYSTEM

1) DIGITAL INPUT

This is indicated by "IN".

Digital input consists of 24 V input and ground (GND) input.

In 24 V input, ON is indicated at 24 V and OFF at open (0 V).

In ground input, ON is indicated at ground (GND) and OFF at open.

As for signal name and specification, refer to P.10-218.

2) DIGITAL OUTPUT

This is indicated by "DOUT".

Digital output consists of 24 V output and ground input.

In 24 V output, ON is indicated at 24 V and OFF at open (0 V).

In ground output, ON is indicated at ground (GND) and OFF at open.

As for signal name and specification, refer to P.10-219.

3) DIGITAL OUTPUT (FEEDBACK SIGNAL)

This is indicated by "DOUT Fb".

This is feedback signal of digital signal (DOUT) and corresponds to digital output condition.

If it does not correspond to digital signal condition, wire breakage or ground fault is presumed.

(2) INPUT, OUTPUT CHECK OF MC1 (MAIN CONTROLLER 1)

(A) Select "MC1" screen in the menu.

The first screen indicates conditions of analog signal of pressure sensors, potentiometers etc.

Unit of indicating figure is V (volt).

As for signal name and specification, refer to P.10-337.

0 V is indicated on non connected point.

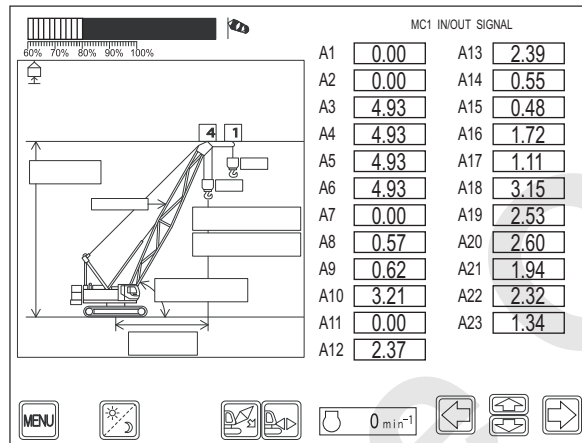

(B) By pushing [NEXT], digital input and digital output are indicated.

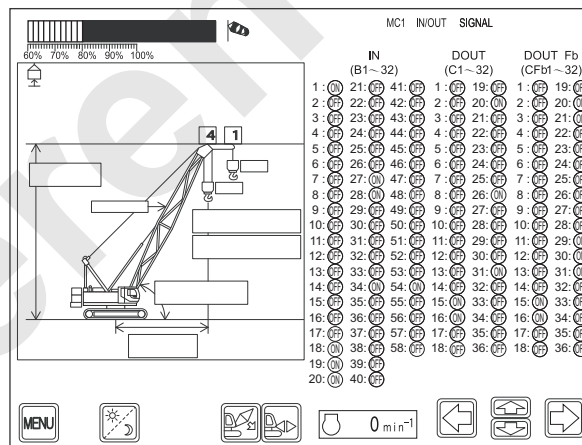

10. ELECTRIC SYSTEM

1) DIGITAL INPUT

This is indicated by "IN".

Digital input consists of 24 V input and ground (GND) input.

In 24 V input, ON is indicated at 24 V and OFF at open (0 V).

In ground input, ON is indicated at ground (GND) and OFF at open.

As for signal name and specification, refer to P.10-338, 10-339.

2) DIGITAL OUTPUT

This is indicated by "DOUT".

Digital output consists of 24 V output and ground input.

In 24 V output, ON is indicated at 24 V and OFF at open (0 V).

In ground output, ON is indicated at ground (GND) and OFF at open.

As for signal name and specification, refer to P.10-340.

3) DIGITAL OUTPUT (FEEDBACK SIGNAL)

This is indicated by "DOUT Fb".

This is feedback signal of digital signal (DOUT) and corresponds to digital output condition.

If it does not correspond to digital signal condition, wire breakage or ground fault is presumed.

- (C) By pushing [NEXT], output of proportional valve becomes indicated.
 Instruct value is indicated on left hand and feedback value on right hand.
 Unit of indicating figure is mA (mille ampere).
 If instruct value is more than 100 mA and feedback value is about 0 mA, wire breakage is presumed.
 As for signal name and specification, refer to P.10-339.

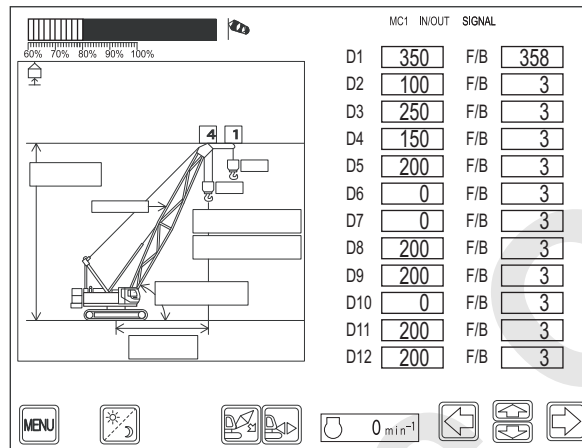

- (D) By pushing [NEXT], analog output and engine status becomes indicated.
 Unit of indicating figure is V (volt).
 This is used as accelerator signal to ECU.
 However this becomes effective only when G-28 accellerator control (MC option set) is "O".

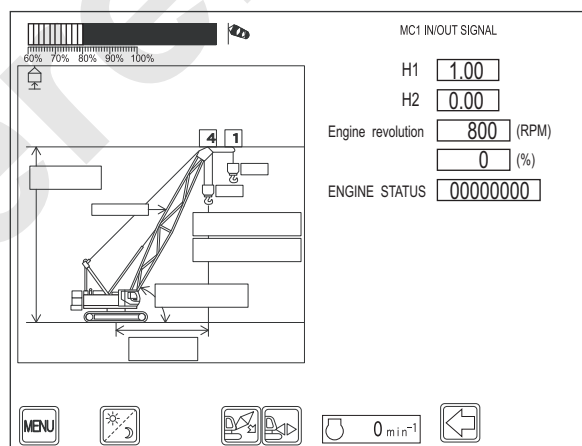

10. ELECTRIC SYSTEM

(3) INPUT, OUTPUT SIGNAL CHECK OF MC2 (MAIN CONTROLLER 2)

(A) Select "MC2" screen in the menu.

The first screen indicates conditions of analog signal of pressure sensors, potentiometers etc.

Unit of indicating figure is V (volt).

As for signal name and specification, refer to P.10-341.

0 V is indicated on non connected point.

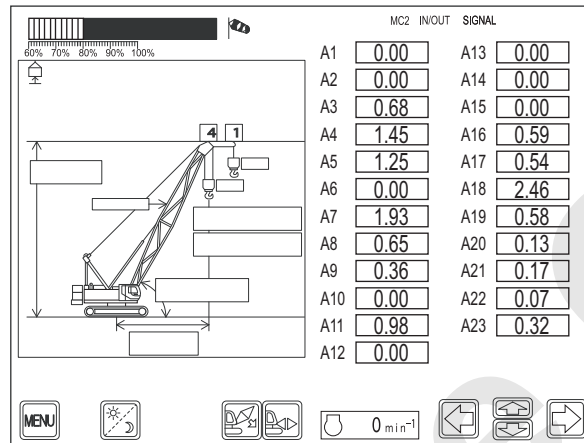

(B) By pushing [NEXT], digital input and digital output are indicated.

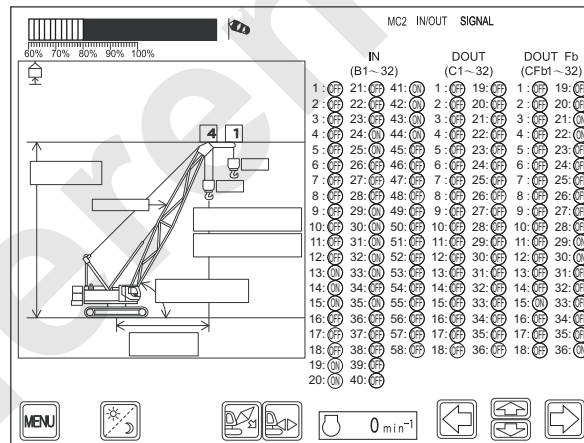

1) DIGITAL INPUT

This is indicated by "IN".

Digital input consists of 24 V input and ground (GND) input.

In 24 V input, ON is indicated at 24 V and OFF at open (0 V).

In ground input, ON is indicated at ground (GND) and OFF at open.

As for signal name and specification, refer to P.10-342, 10-343.

2) DIGITAL OUTPUT

This is indicated by "DOUT".

Digital output consists of 24 V output and ground input.

In 24 V output, ON is indicated at 24 V and OFF at open (0 V).

In ground output, ON is indicated at ground (GND) and OFF at open.

As for signal name and specification, refer to P.10-344.

3) DIGITAL OUTPUT (FEEDBACK SIGNAL)

This is indicated by "DOUT Fb".

This is feedback signal of digital signal (DOUT) and corresponds to digital output condition.

If it does not correspond to digital signal condition, wire breakage or ground fault is presumed.

Referen

10. ELECTRIC SYSTEM

(C) By pushing [NEXT], output of proportional valve becomes indicated.

Instruct value is indicated on left hand and feedback value on right hand.

Unit of indicating figure is mA (mille ampere).

If instruct value is more than 100 mA and feedback value is about 0 mA, wire breakage is presumed.

As for signal name and specification, refer to P.10-343.

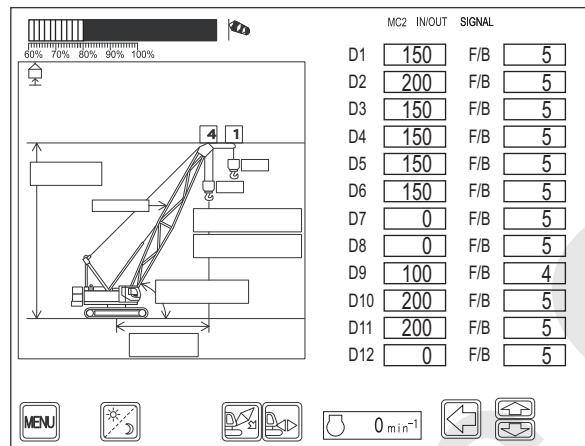

10.2.7 ML FUNCTION SETTING

1. Push [ML FUNCTION SETTING] in the maintenance menu.

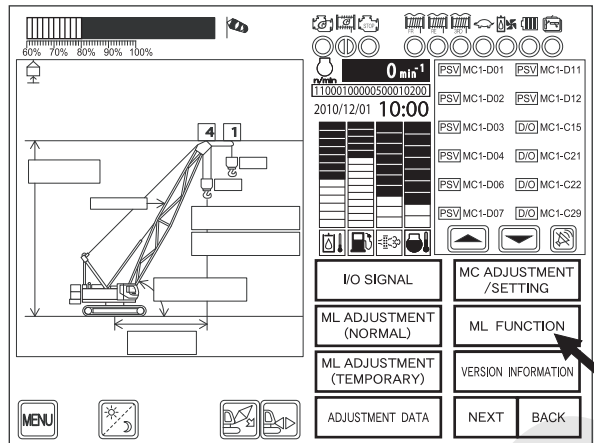

2. Setting item becomes indicated.

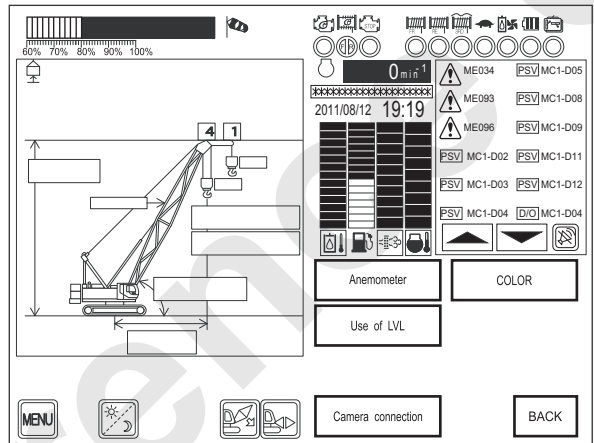

10. ELECTRIC SYSTEM

(1) OPTION SETTING OF ANEMOMETER

This is to set with or without wind speed meter.

(EX) In case of anemometer installed.

(A) Push [ANEMOMETER] in the menu.

(B) Option setting screen of anemometer becomes indicated.

(C) Push [Enable].

* The selected side turns to blue indication.

(D) Push [OK].

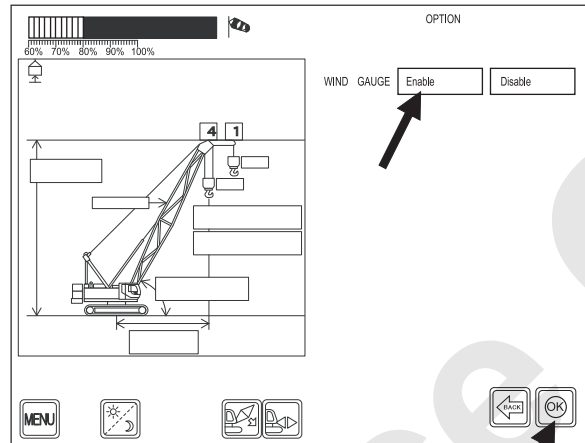

(2) MAKING LVL FUNCTION EFFECTIVE

This is to set LVL (auto stop load ratio) effective or not effective.

Refer to P.10-260 to P.10-262.

LVL setting for setting procedure of LVL value.

(EX) In case of making LVL function effective.

(A) Push [USE OF LVL] in the menu.

(B) LVL function screen becomes indicated.

(C) Push [Enable].

* The selected side turns to blue indication.

(D) Push [OK].

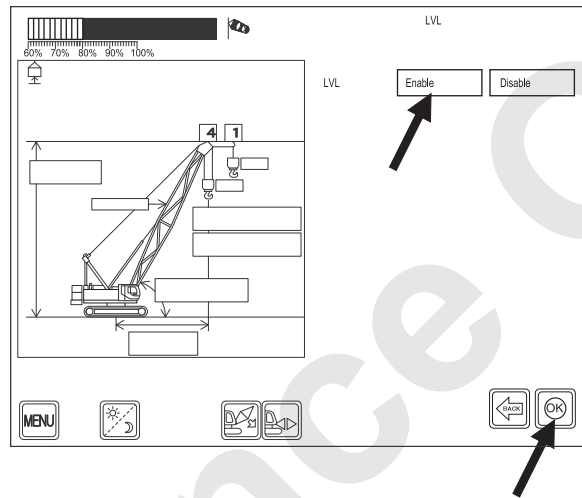

10. ELECTRIC SYSTEM

(3) SETTING OF CAMERA CONNECTION

This is to set with or without camera.

(EX) In case camera is added to channel 1.

(A) Push [CAMERA CONNECTION] in the menu.

(B) Camera connection setting screen becomes indicated.

(C) Push [Enable] of channel 1.

* The selected side turns to blue indication.

(D) Push [SET].

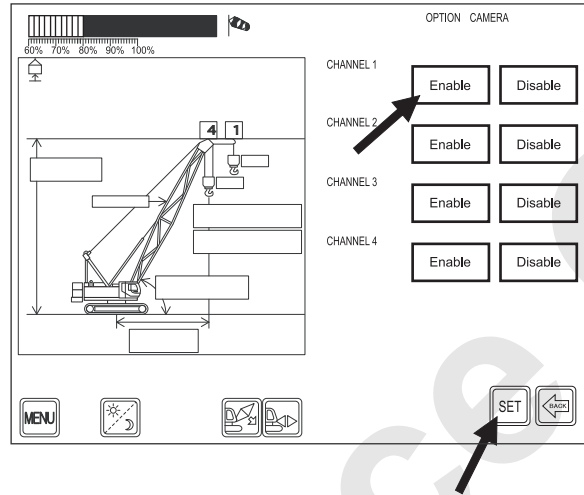

(4) SETTING OF CRANE BODY COLOR

This is to set crane body color.

(EX) In case body color is selected to yellow.

(A) Push [Color] in the menu.

(B) Push [Enable] .

(C) Push [Yellow] area.

(D) Push [OK].

10.2.8 DATA COPY, FORMAT

1. Push [DATA COPY, FORMAT] in the maintenance menu.

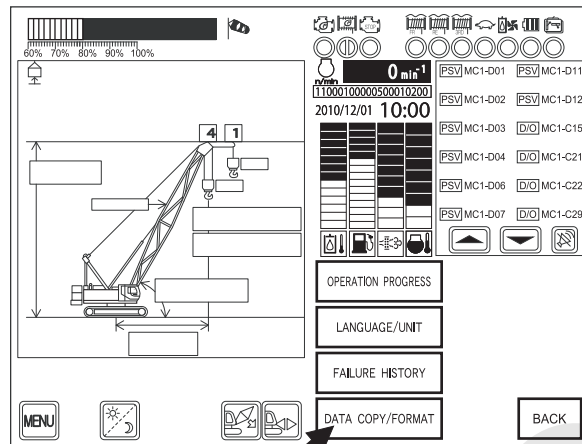

2. Items become indicated.

(1) ADJUSTMENT DATA READING OUT

This reads out backup data in the data card into memory in the controller.

Memorized data in the controller are overwritten and is erased.

Actual data to be used for calculation is those in the controller.

Special caution is required for this handling.

(2) ADJUSTMENT DATA WRITING IN

This is to copy the memorized data in the controller to the data card. (adjustment data back up)

(3) ADJUSTMENT DATA FORMATTING

This is to format the adjustment data memorized in the controller.

The backup data in the data card is not formatted.

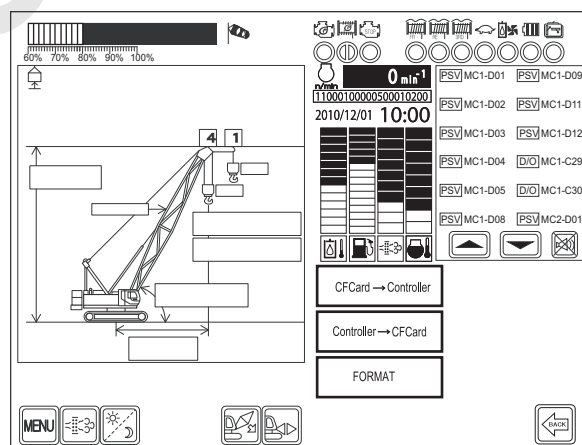

10. ELECTRIC SYSTEM

(A) ADJUSTMENT DATA READING OUT

This is to read out the adjusted value (backup data) in the data card to the memory in the controller.

Note

When using this function, the data in the controller being used for calculation is overwritten. Be careful not to use in error.

Select [CF Card → Controller] in the menu.

The screen shown right becomes indicated.

Push [SET] for 3 seconds to execute.

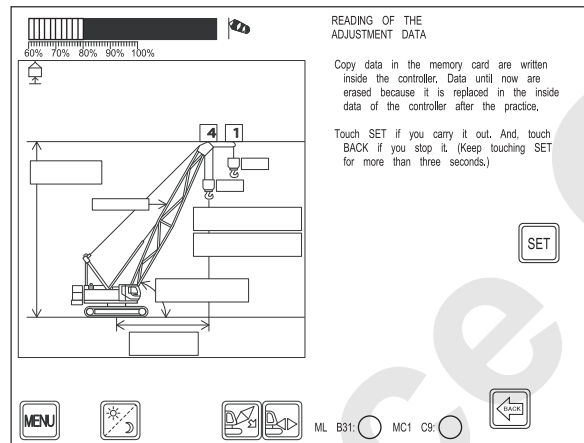

When completed properly, the screen shown below is indicated.
 By pushing [OK], the screen returns to the previous one.

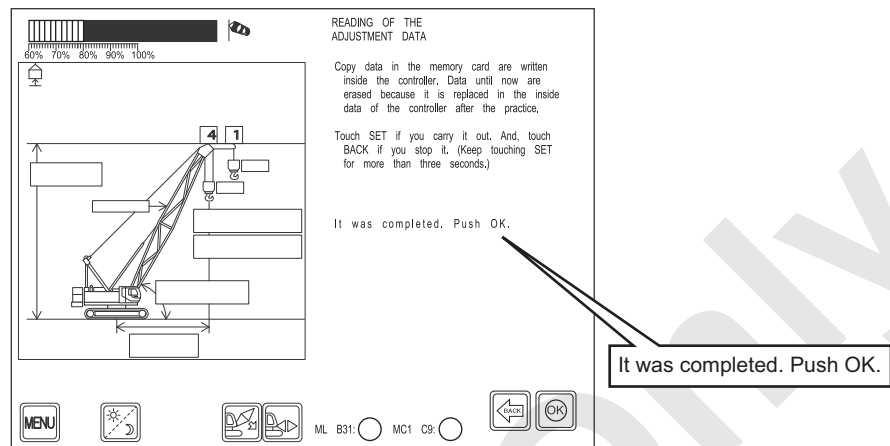

After execution, if error message as shown below is indicated, data card failure (including not enough insertion) is presumed. Re-insert the card and try again.
 By pushing "BACK", screen returns to the previous one.
 Unless both of ML B31 and MC1 C9 lamps indicated on lower part of the screen light up, the card can not be accessed and reading out would not be completed properly.
 In this case, check the function of ML adjusting mode select relay (R-36).

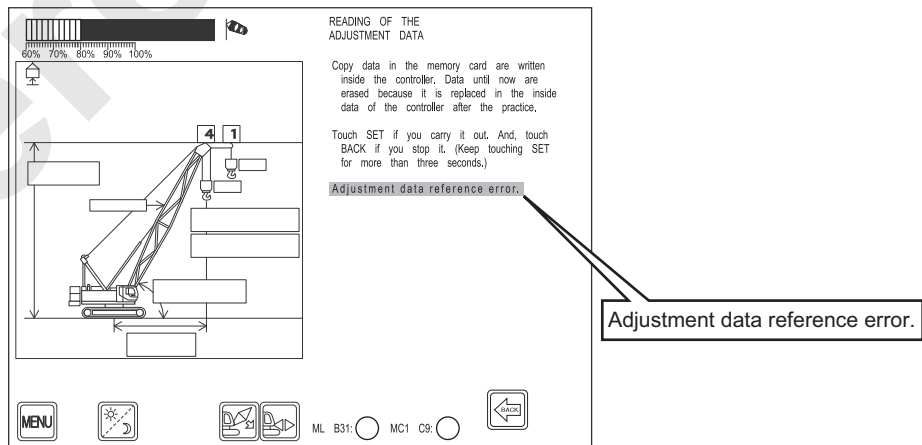

10. ELECTRIC SYSTEM

(B) ADJUSTMENT DATA WRITING IN

This is to copy the adjustment data in the memory of the controller to the data card.

* Normally whenever adjustment is done, data is copied to the card, but this is used to copy forcibly.

Select [Controller → CF Card] in the menu.

The screen shown right becomes indicated.

Push [SET] for 3 seconds to execute.

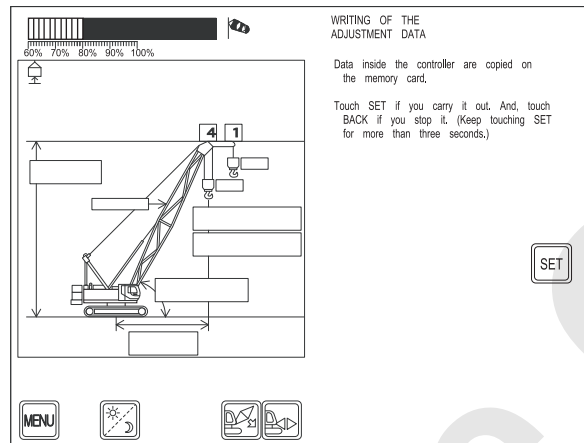

When completed properly, the screen shown right becomes indicated.

By pushing [OK], the screen returns to the previous one.

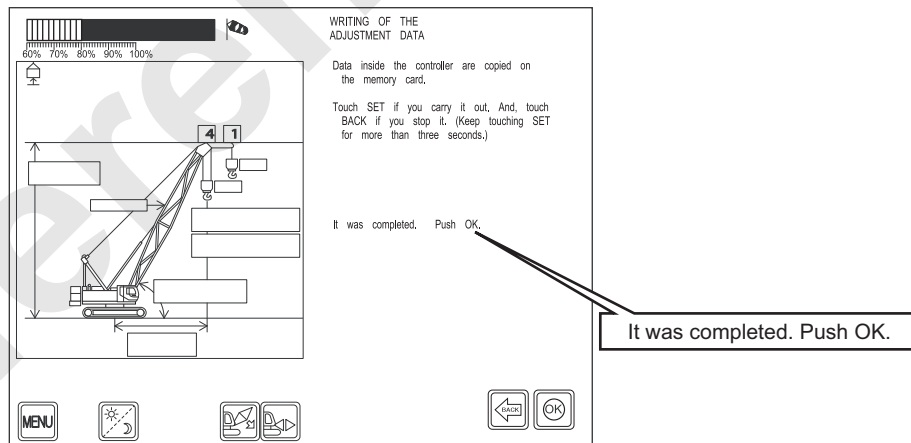

After execution, if error message as shown right is indicated, data card failure (including not enough insertion) is presumed. Re-insert the card and try again.

By pushing [BACK], screen returns to the previous one.

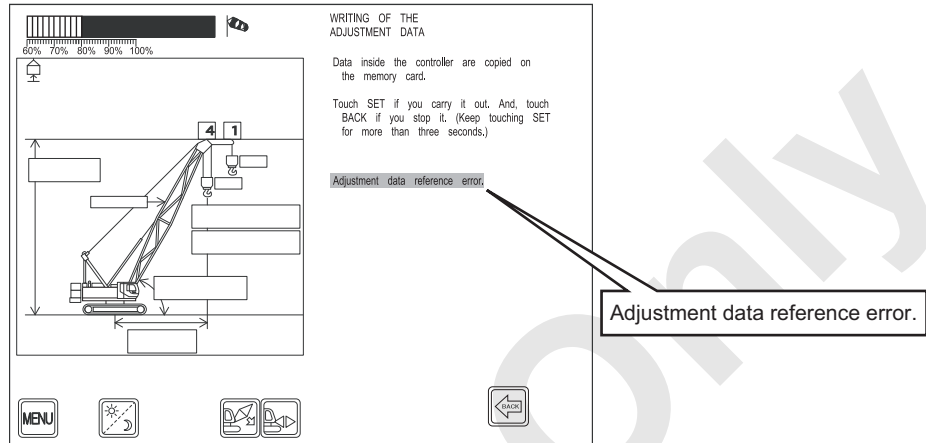

(C) ADJUSTMENT DATA FORMATTING

This is to format the adjustment data in the memory in the controller.

Note

When using this function, the data in the controller being used for calculation is overwritten. Be careful not to use in error.

Select [FORMAT] in the menu.
The screen shown below is indicated. Push [SET] for 3 seconds to execute.

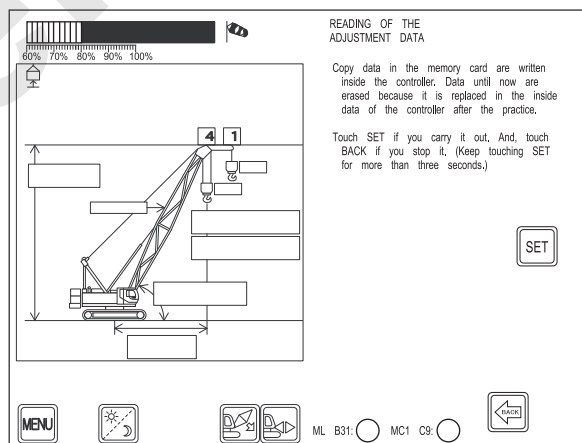

10. ELECTRIC SYSTEM

When completed properly, the screen shown below is indicated.

By pushing [OK] the screen returns to the previous one.

Unless both of ML B31 and MC1 C9 lamps indicated on lower part of the screen light up, the card can not be accessed and reading out would not be completed properly.

In this case, check the function of ML adjusting mode select relay (R-36).

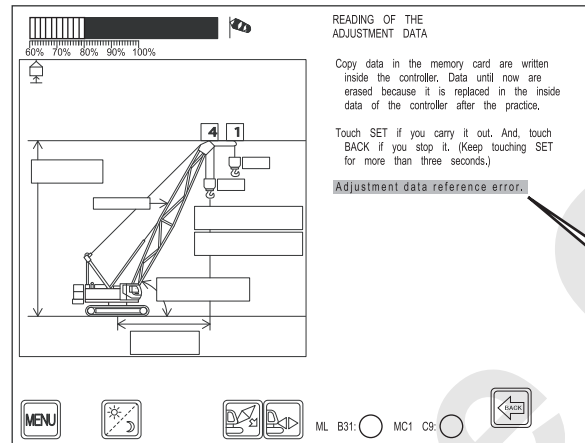

10.2.9 LANGUAGE, UNIT SETTING

1. Push [LANGUAGE/UNIT] in the maintenance menu.

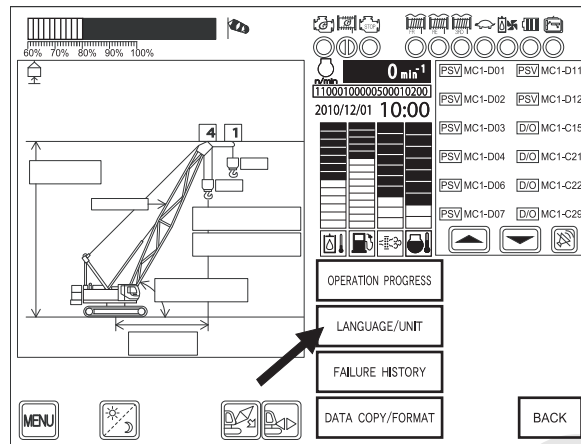

2. Item becomes indicated. Select the required language, unit.

	Indicated language	Indicated unit
JPN	Japanese	m, t
ENG (ft • lbs)	English	feet, klbs
ENG (m • t)	English	m, t

Selected item becomes indicated in blue letter.
After select, push [OK].

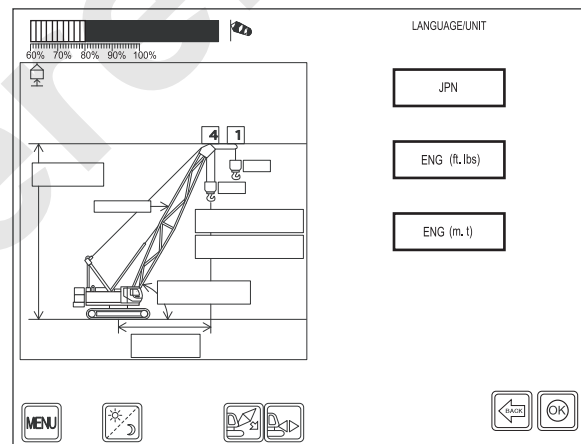

10. ELECTRIC SYSTEM

10.2.10 ML ADJUSTMENT (NORMAL)

1. Push [ML ADJUSTMENT (NORMAL)] in the maintenance menu.

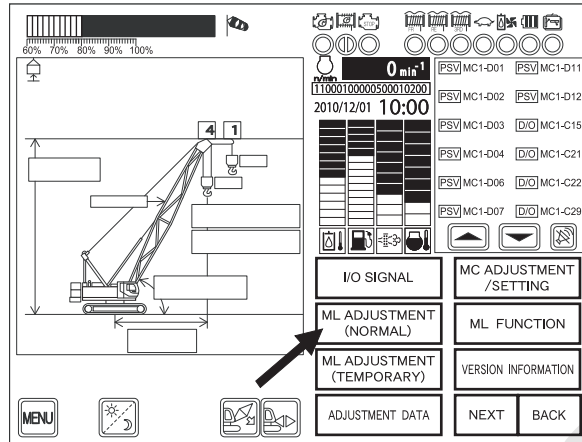

2. Adjustment menu becomes indicated.

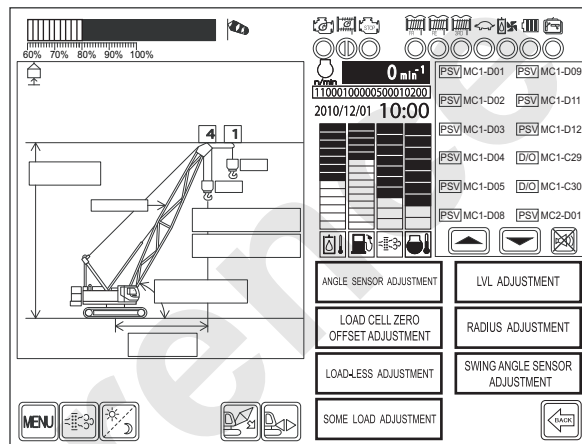

Angle sensor adjustment	This is used when error between indication of boom angle, jib angle mast angle become larger and their actual angle become larger or whenever the angle detector is replaced.
Loads cell zero offset adjustment	This is used when output voltage is shifted from 1.000 V when load is not applied to load cell. This becomes necessary whenever load detector or cable is replaced.
Load-less adjustment	This is used when the hook weight is not properly indicated.
Some load adjustment	This is used when error becomes large on actual load indication after without load adjustment is completed.
LVL adjustment	This is to change auto stop point (warning point).
Work radius adjustment	This is used when error of work radius indication and actual work radius becomes larger.
Swing sensor adjustment	This is used when screen indication of swing direction and actual swing direction varies. This is also used whenever swing angle sensor (slip ring built-in) is replaced.

(1) ANGLE DETECTOR ADJUSTMENT

Select [ANGLE DETECTOR ADJUSTMENT] in the adjustment menu.

Angle detector connected to presently set attachment becomes indicated.

(Figure below shows example of crane with aux. sheave.)

In case with jib, jib angle detector becomes indicated and in case with mast, mast angle detector becomes indicated.

Select the adjustment required angle detector.

This procedure explains boom angle detector as an example. Jib angle detector and mast angle detector are adjusted in the same procedure.

After boom is raised to near upper limit angle lower the boom slightly and push [LOWER BOOM ANGLE SENSOR].

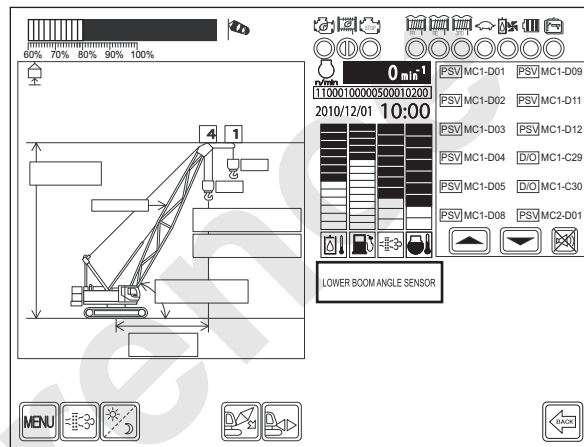

10. ELECTRIC SYSTEM

Touch angle indicating area.

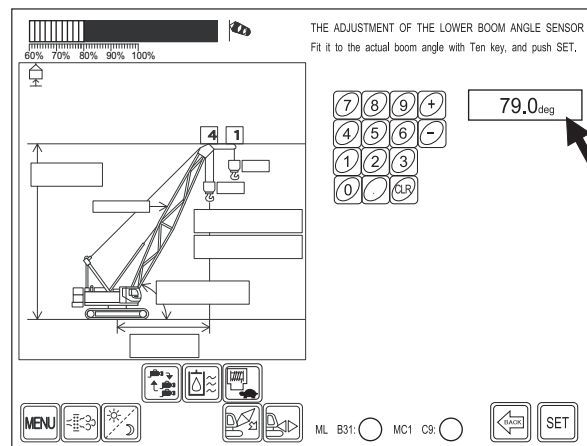

Angle indicating area becomes indicated in reverse and digit input becomes possible.

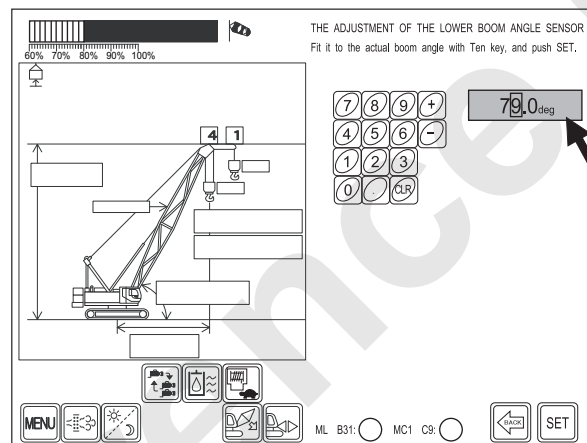

Measure the actual boom angle with the level gauge and angle meter and input digit with numeric key.

(EX) In case of input [79.5], input [7], [9], [.] [5].

After input, push [SET].

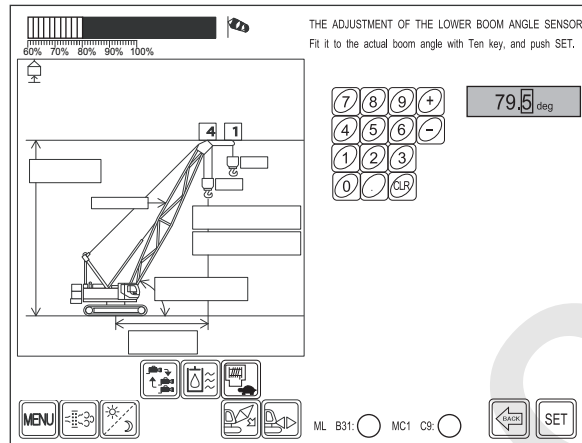

Lower the boom for more than 25 degrees and stop. Then push [SET].

CAUTION

Angle of 25 degrees is just a guideline for lowering the boom, and this guideline should not be necessarily observed. However, remember that the adjustment is effective if the boom is lowered with an angle as large as possible.

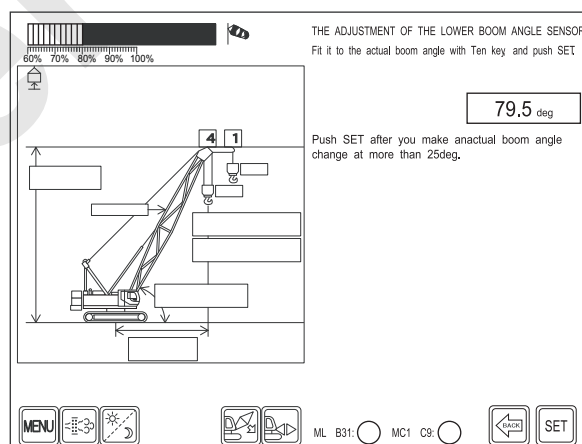

10. ELECTRIC SYSTEM

Touch the second angle indicating area.

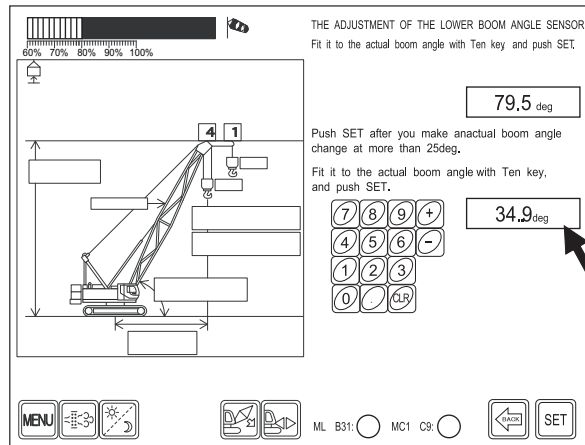

Angel indicating area becomes indicated in reverse and digit input becomes possible.

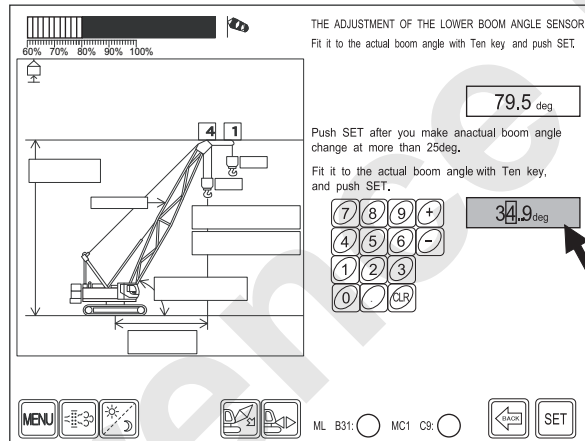

Measure the actual boom angle with the level gauge and angle meter and input digit with numeric key.
 (EX) In case of input [35.7], input [3], [5], [.] [7]. After input, push [SET].

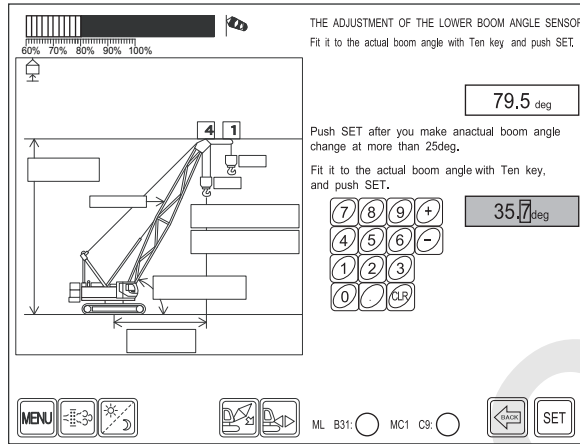

When the adjustment is properly completed, the message shown below is indicated.

"Adjustment is properly completed. Push [SET]"

By pushing [SET], the screen returns to the previous one.

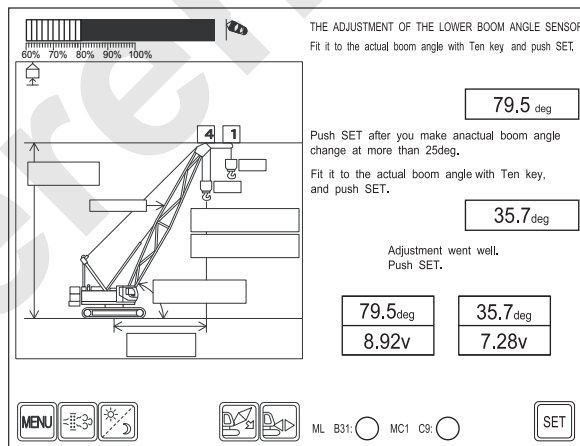

10. ELECTRIC SYSTEM

If the adjustment is not properly completed, the message shown below is indicated.

By pushing [SET], screen returns to the one during adjusting. Re-check the procedure and start adjustment again.

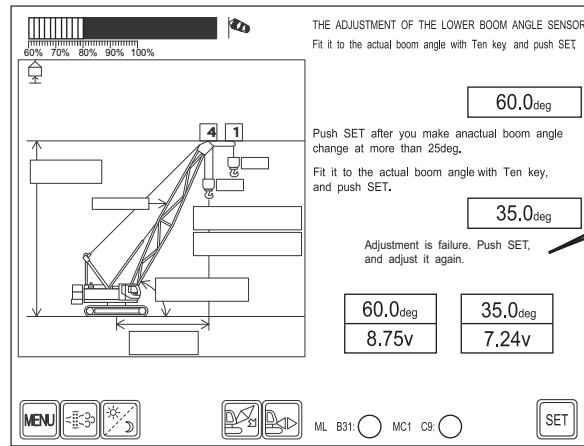

(2) LOAD DETECTOR ZERO ADJUSTMENT

Select [LOAD CELL ZERO OFFSET ADJUSTMENT] in the adjustment menu.

The load detectors used in the presently set attachment become indicated. Select the required load detector to be adjusted.

* Right screen shows inclined crane as an example.

In case of adjusting jib load detector, luffing configuration must be selected. If multi number of load detectors are used, multi number of load detectors become indicated. Select the required load detector to be adjusted.

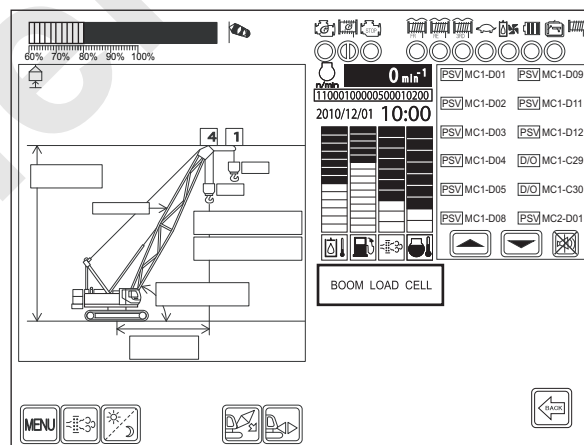

Release the tension on the boom hoist rope to "zero" by releasing the boom hoist rope as much as possible or by removing the load detector.
Push [SET] when prepared.

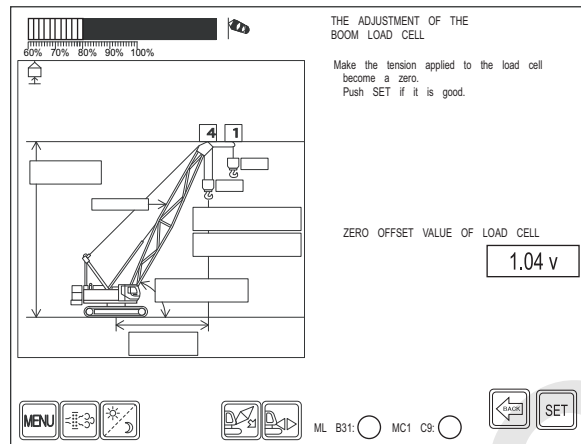

CAUTION

When the displayed load cell voltage is not in the range from 0.8 to 1.2 V, the load cell is judged to be faulty and the adjustment is rejected. In such a case, replace the load cell.

The message shown below becomes indicated when the adjustment is properly completed.

By pushing [SET], screen returns to the previous one.

10. ELECTRIC SYSTEM

If the adjustment is not properly completed, the message shown below is indicated.

By pushing [SET], screen returns to the one during adjusting. Re-check the procedure and start adjustment again.

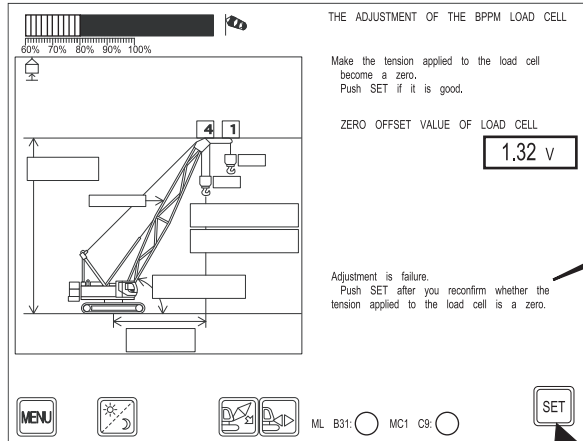

Adjustment is failure.
Push SET after you reconfirm whether the tension applied to the load cell is a zero.

(3) LOAD LESS ADJUSTMENT

Set the load to only the hook installed.
Adjust each hook position based on the table below.

(CKE Series)

Type of attachments	Mode	Weight of hook block to be entered during adjustment	Weight of hook block when load is adjusted	
			Hook of mode selected	Other hooks
Crane	Main lifting	Main hook	Boom foot	—
Crane with auxiliary sheave	Main lifting	Main hook	Boom foot	*1
	Auxiliary sheave lifting	Auxiliary sheave hook	Boom foot	*1
Crane with jib	Main lifting	Main hook	Boom foot	*1
	Jib lifting	Jib hook	Boom foot	*1
Tower crane	—	Main hook	Boom foot	*1
Luffing crane (with main hook)	Main lifting	Main hook	Boom foot	*1
	Jib lifting	Jib hook	Boom foot	*1
Luffing crane (with aux. sheave hook)	Jib lifting	Jib hook	Boom foot	*1
	Auxiliary sheave lifting	Auxiliary sheave hook	Boom foot	*1
Luffing crane (jib hook only)	Jib lifting	Jib hook	Boom foot	*1

(CK Series)

Type of attachments	Mode	Weight of hook block to be entered during adjustment	Weight of hook block when load is adjusted	
			Hook of mode selected	Other hooks
Crane	Main lifting	Main hook	Boom foot	—
Crane with auxiliary sheave	Main lifting	Main hook + Aux. sheave hook	Boom foot	*1
	Auxiliary sheave lifting	Main hook + Aux. sheave hook	Boom foot	*1
Crane with jib	Main lifting	Main hook + Jib hook	Boom foot	*1
	Jib lifting	Main hook + Jib hook	Boom foot	*1
Luffing crane (with main hook)	Main lifting	Main hook + Jib hook	Boom foot	*1
	Jib lifting	Jib hook	Boom foot	*1
Luffing crane (with aux. sheave hook)	Jib lifting	Jib hook + Aux. sheave hook	Boom foot	*1
	Auxiliary sheave lifting	Jib hook + Aux. sheave hook	Boom foot	*1
Luffing crane (jib hook only)	Jib lifting	Jib hook + Aux. sheave hook	Boom foot	*1

*1 = 1/4 of distances from boom point sheave to ground.

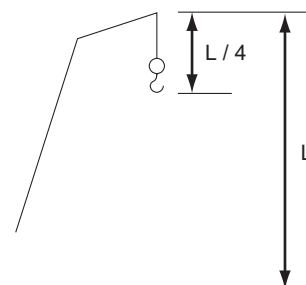

10. ELECTRIC SYSTEM

Perform this adjustment by boom lowering motion control.

Adjusting points shall be max. boom (jib) angle point and min. boom (jib) angle point and random selected 5 points between them.

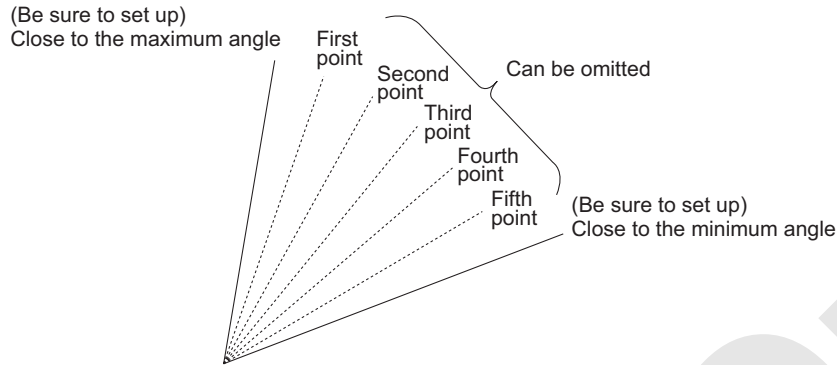

Max. boom (jib) angle and min. boom (jib) angle points are essentially required but points between them can be neglected.

There is no rule on number of points and their interval.

However more precise adjustment becomes possible with more points on wider angle range.

Adjustment would become easier if the adjustment points (angle) are set in advance in the range between the upper limit angle and lower limit angle divided into 6 in the adjustment required configuration.

Select [LOAD-LESS ADJUSTMENT] in the adjustment menu.
 Touch load indicating area.

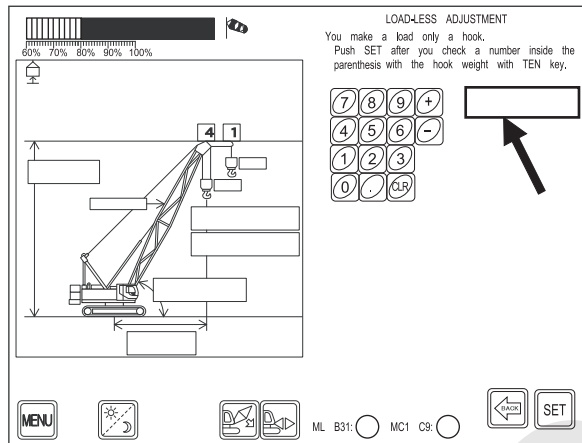

Load indicating area turns in reverse indication and digit input becomes possible.

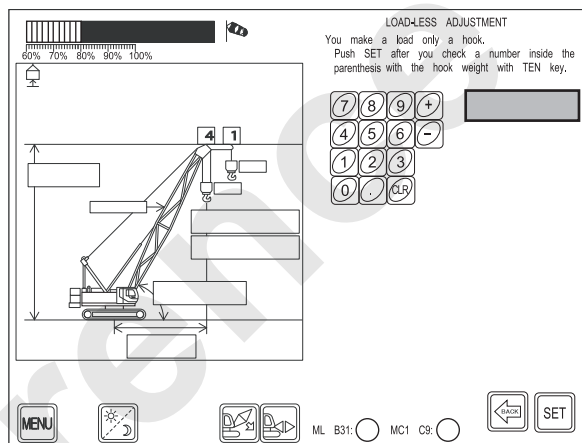

10. ELECTRIC SYSTEM

Input hook weight with digit key.

Refer to the table in the previous page for hook weight to be input.

(EX) In case of input [2.0], input [2], [.] , [0].

After input, push [SET].

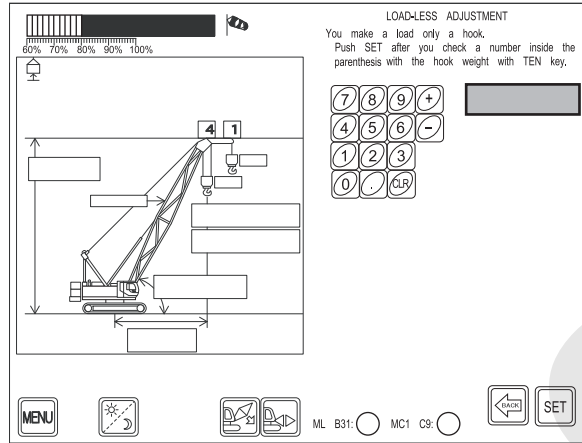

After raising the boom to almost the upper limit angle and then lower by about 1 degree and then stop.

CAUTION

There are some error in boom raising and boom lowering. So ensure to stop in boom lowering.

Push [SET].

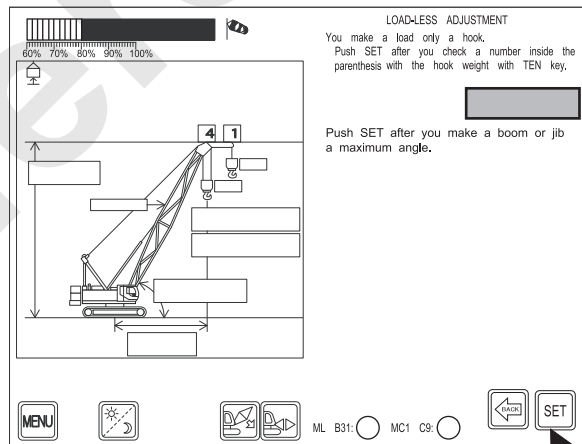

Lower the boom and stop. Then push [SET].
 During boom lowering motion, control the hook raising motion to keep the hook in the same height.

If the points in between are to be skipped, push [SKIP].
 They are skipped to the minimum angle.

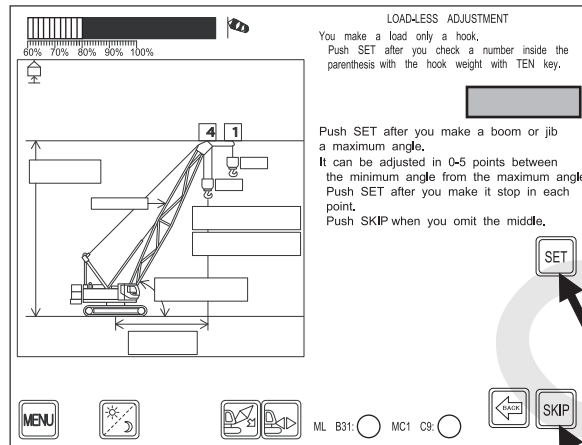

By pushing [SET], message memorizing the first point is indicated.

After lowering the boom, push [SET].

If the points in between are to be skipped, push [SKIP].
 They are skipped to the minimum angle.

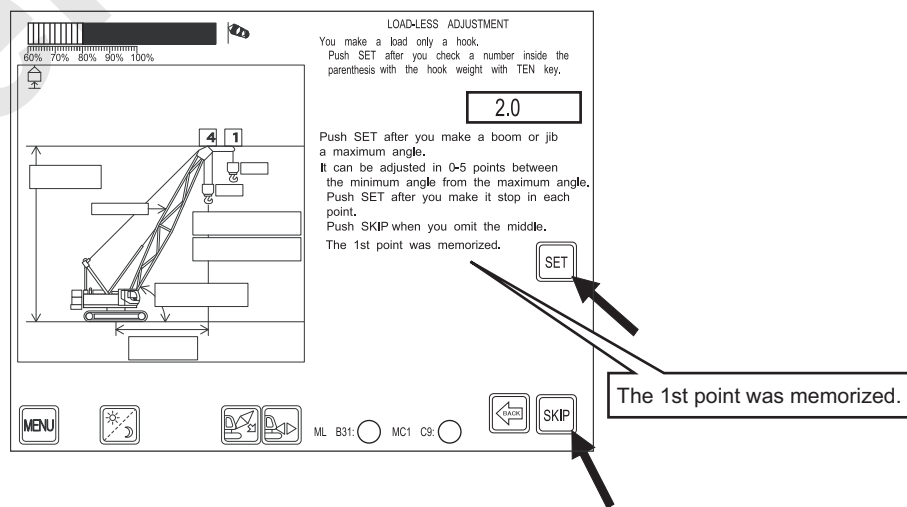

10. ELECTRIC SYSTEM

By pushing [SET], message memorizing the second point is indicated.

Second point is memorized. After lowering the boom further, push [SET].

If the points in between are to be skipped, push [SKIP].

They are skipped to the minimum angle.

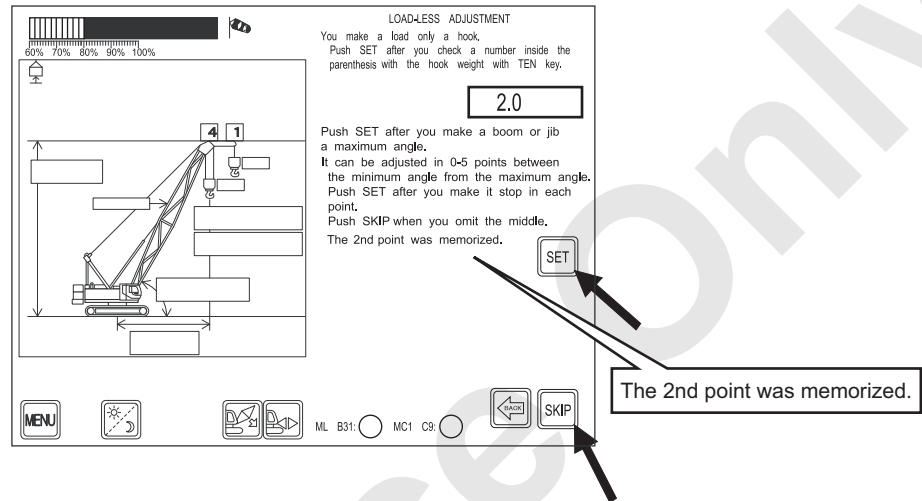

Repeat the adjustment in the same way in sequence. When 5th point is memorized, message requesting to set the angle to minimum and push [SET] is indicated.

Lower the boom to almost minimum angle and push [SET].

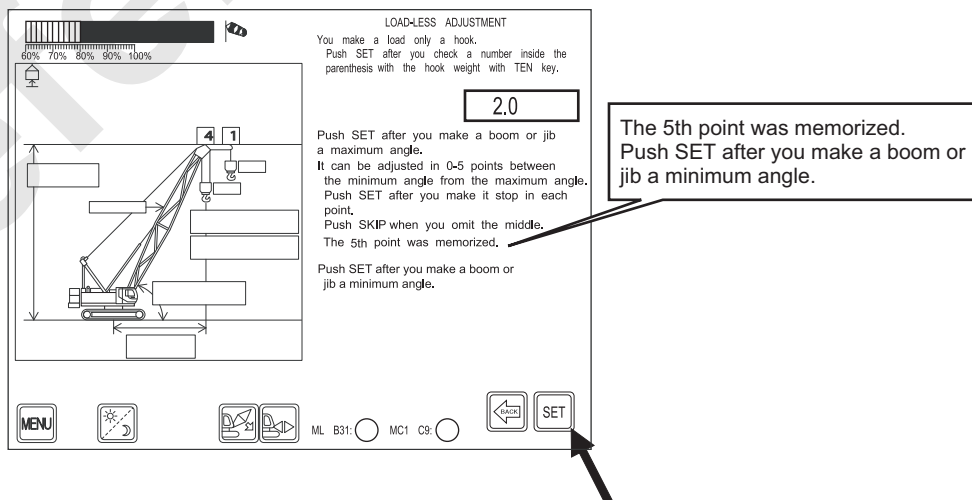

If the adjustment is properly completed, the message shown below is indicated.

At the same time K1, K2 values are indicated as adjustment result.

By pushing [SET], screen returns to the previous one.

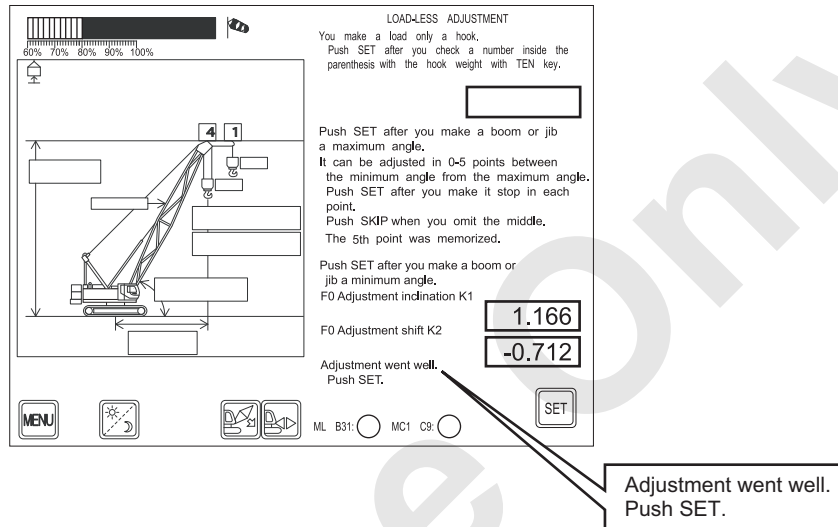

If the adjustment is not properly completed, the message shown below is indicated.

After pushing [SET], start adjustment again.

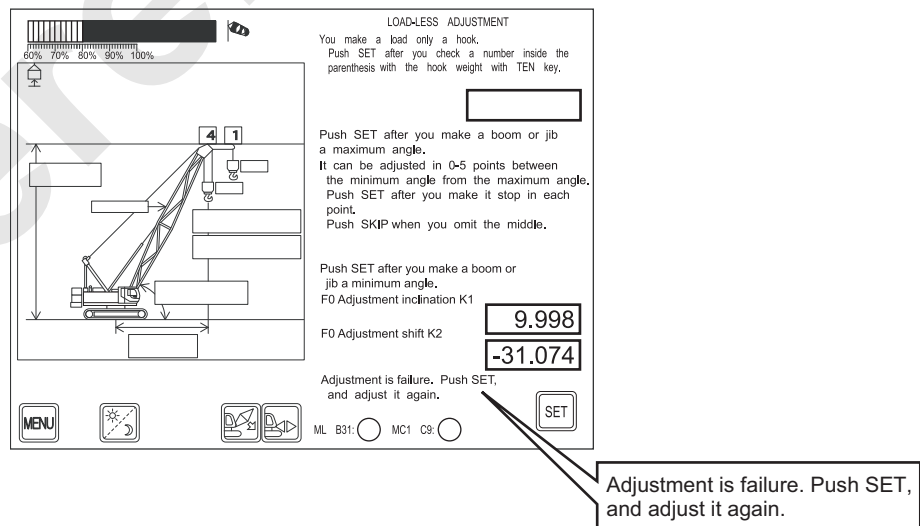

In without load adjustment, if adjustment on more than two boom (jib) length is done, on boom (jib) length which is not adjusted yet, calibration by interpolation by two closest length adjustment values is applied.

10. ELECTRIC SYSTEM

(4) SOME LOAD ADJUSTMENT

Only the different point to without load adjustment is the load value input first.

The rest are same.

Different point to without load adjustment ONLY is explained here.

Firstly lift the weight known load.

Select [SOME LOAD ADJUSTMENT] in the adjustment menu.

By touching load indicating area, indication turns into reverse and digit input becomes possible. Input load weight actually being lifted with digit key and push [SET].

* This includes weight of hook and lifting sling.

The procedure afterward is as same as without load.

Proceed as without load adjustment.

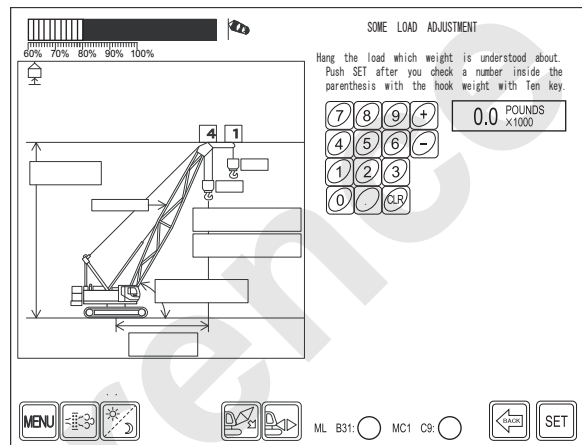

If the adjustment is properly completed, the message shown below is indicated.

At the same time K3, K4 values are indicated as adjustment result.

By pushing [SET], screen returns to the previous one.

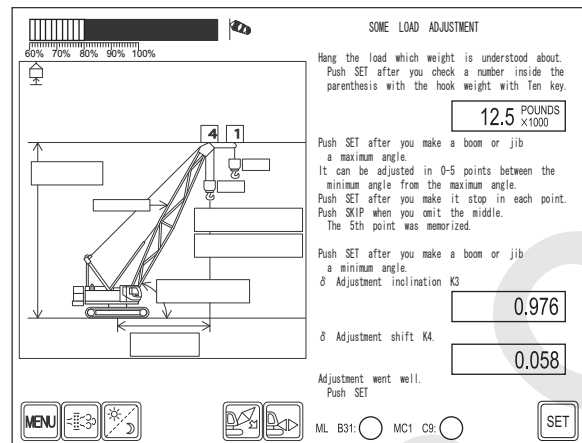

If the adjustment is not properly completed, the message shown below is indicated.

After pushing [SET], start adjustment again.

CAUTION

With load adjustment is likely to be affected with lifting load swinging.

Therefore when the actual load indication moves significantly, wait until the lifting load swinging stops and push [SET].

10. ELECTRIC SYSTEM

(5) LVL ADJUSTMENT

LVL means the load ratio to stop automatically.
Normally auto stop load ratio is 105% but with this function this load ratio can be changed to 90 to 110%.

CAUTION

LVL function is only effective when "EFFECTIVE" is set in "LVL SETTING" in the "SETTING". If "NOT EFFECTIVE" is selected, normal 105% is applied even value is changed in this function.

Select [LVL ADJUSTMENT] in the adjustment menu.
Touch the load ratio indicating area.

The indicating area becomes reverse indication.
 Input value with digit key.

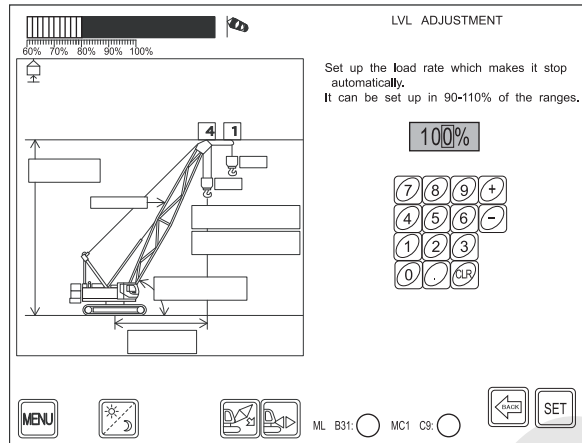

After value input is completed, push [SET].
 Setting is completed and screen returns to previous one.

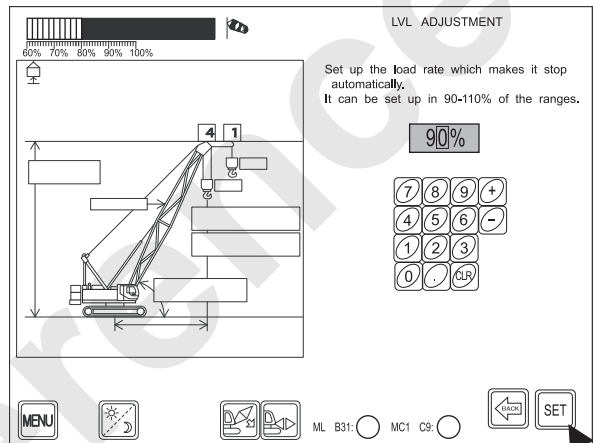

10. ELECTRIC SYSTEM

LVL Function

The following drawings are some examples of LVL function.

(A) When the LVL function is OFF.

If the loading ratio is 105% or more while the LVL function is not actuated, operation toward the hazardous side is automatically stopped. Note that hysteresis of 5% must be considered for restoration from the automatic stop status.

When the loading ratio is returned to 100%, the automatic stop status is cancelled. When the loading ratio is 90% or more, intermittent alarm sounds are emitted.

Continuous alarm sounds are emitted when the loading ratio is 100% or more.

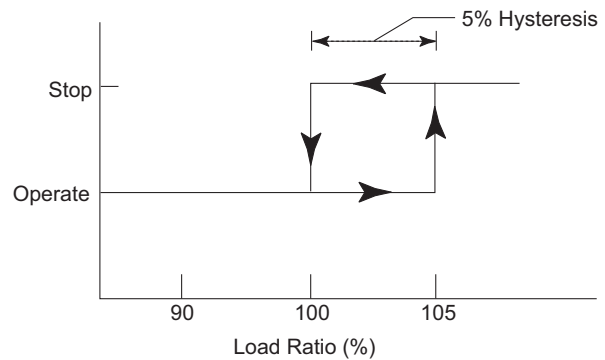

(B) When the LVL function is ON and set to 90%.

If the loading ratio is 90% or more, operation toward the hazardous side is automatically stopped. The machine is restored from the automatic stop status when the loading ratio is less than 85%.

When the loading ratio is 90%, continuous alarm sounds are emitted. No forecasting sound (intermittent sound) will be emitted.

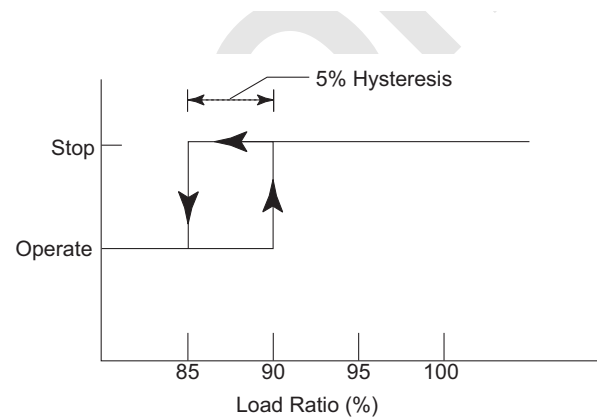

(C) When the LVL function is ON and set to 110%.

When LVL is set at 110%, the figure above applies. Please note the following points.

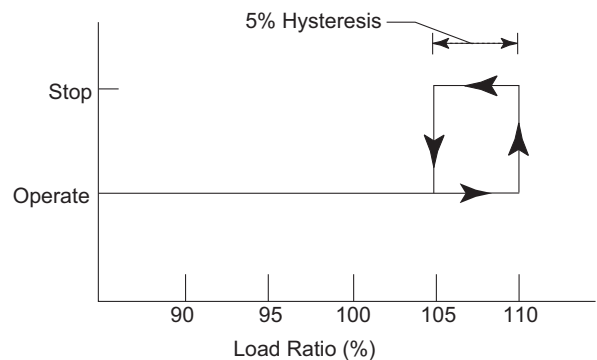

- LVL is also affected by the work area limit parameters. It operates by referencing the smaller value set by the Load Setting switch in "Setting the Work Area Limit Values".
- The LVL operational lag (hysteresis) is -5%.
- The load ratio is not affected by LVL function.
- When the loading ratio is 90%, forecasting sounds (intermittent sounds) are emitted. Alarm sounds (continuous sounds) are emitted when the loading ratio is 100% (not affected by the LVL function).

(6) WORK RADIUS ADJUSTMENT

This is used when difference between the indicated work radius and the actual work radius is large due to the boom deflection etc.



Ensure to check if there is any error in angle indication. If error is larger than 0.3 degrees carry out angle adjustment first.

Raise the boom (jib) to almost upper limit angle and then lower by about 1 degree and then stop.

Select [RADIUS ADJUSTMENT] in the adjustment menu.

Touch the radius indication area.

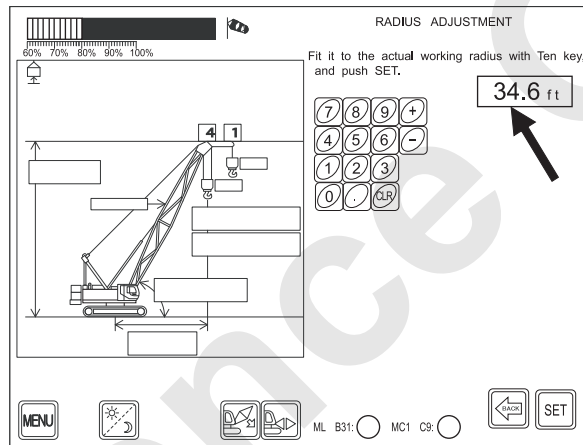

Radius indication area becomes reverse indication and digit input becomes possible.

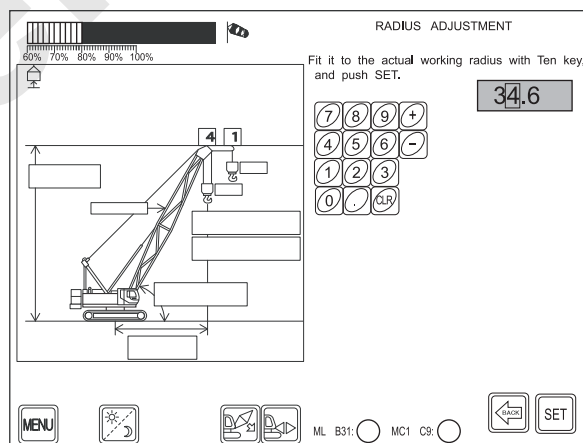

10. ELECTRIC SYSTEM

Input actually measured work radius with digit key.

(EX) In case of input [35.0], input [3], [5], [.] [0].

After input, push [SET].

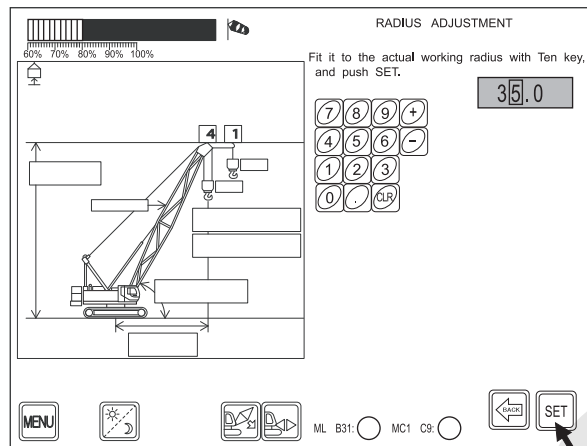

Lower the boom (jib) to almost min. angle and stop.

Then push [SET].

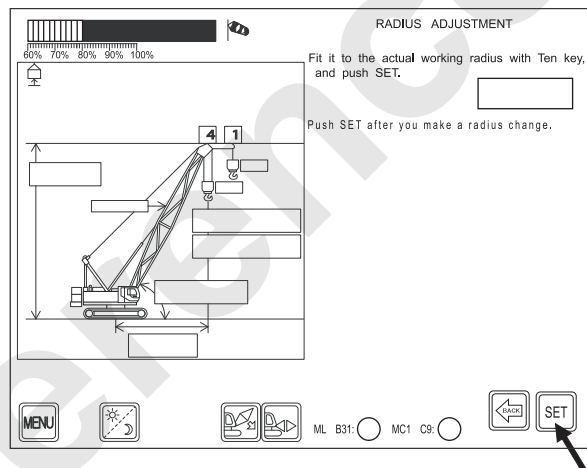

Touch the radius indication area.

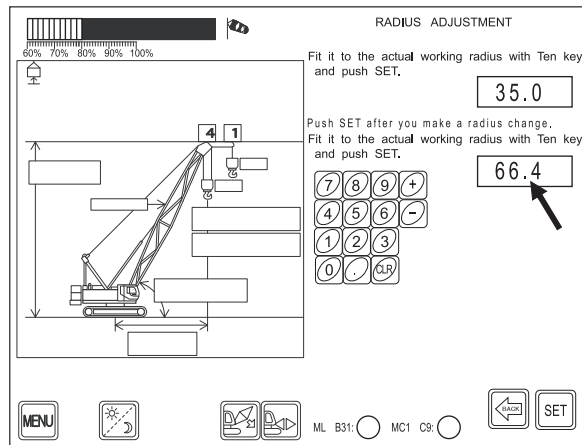

Input actually measured work radius with digit key.
 (EX) In case of input [67.0], input [6], [7], [.] [0].
 After input, push [SET].

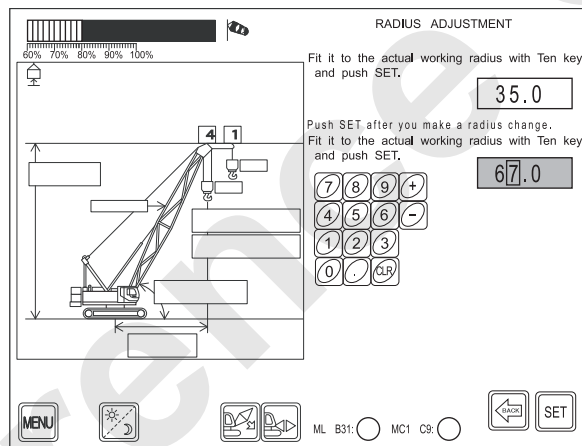

10. ELECTRIC SYSTEM

If the adjustment is properly completed, the message shown below is indicated.

By pushing [SET], screen returns to the previous one.

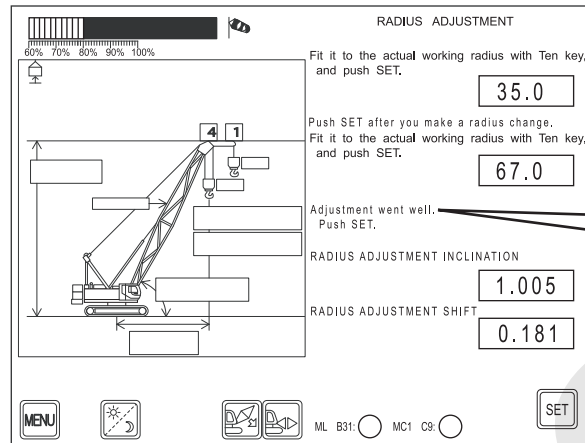

If the adjustment is not properly completed, the message shown below is indicated.

By pushing [SET], screen returns to the one during adjusting. Re-check the procedure and start adjustment again.

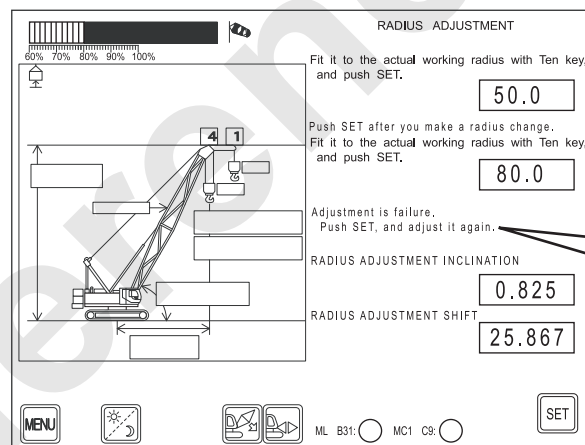

(7) SWING ANGLE ADJUSTMENT

Select [SWING ANGLE ADJUSTMENT] in the adjustment menu.

Face the crane toward front (idler side of crawler) and fix with the swing lock pin. Push [FR].

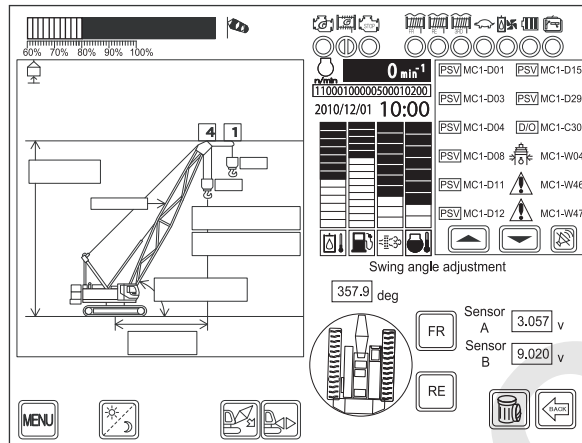

If the indication changes from [FR] to [OK], front side adjustment is properly completed.

Swing the crane by 180 degrees and face it toward rear (propel motor side) and fix with the swing lock pin.

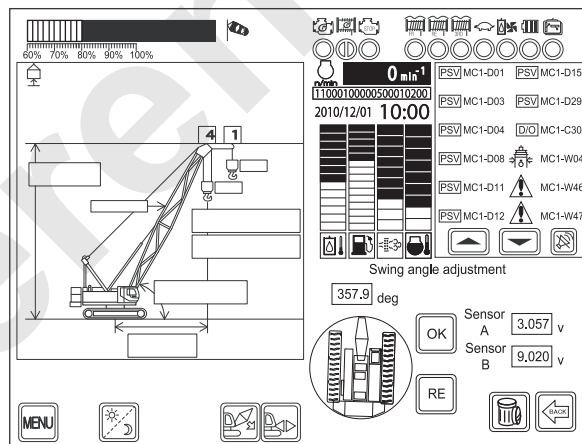

10. ELECTRIC SYSTEM

Push [RE].

If indication changes from [RE] to [OK], rear side adjustment is properly completed.

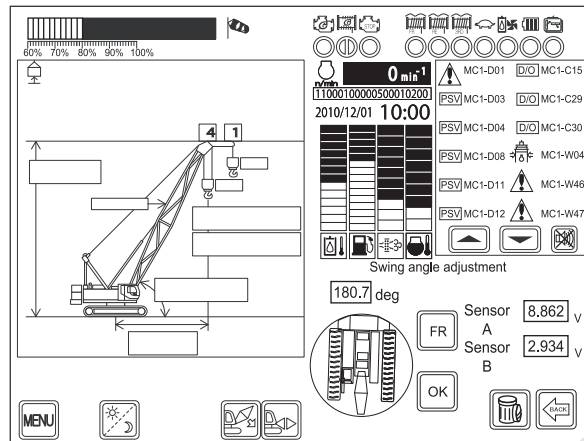

When either [FR] or [RE] is pushed and "NG" is indicated, adjustment is in error.

Check if the crane direction or sensor voltage is correct and start adjustment again.

Below screen indicates NG in rear adjustment as an example.

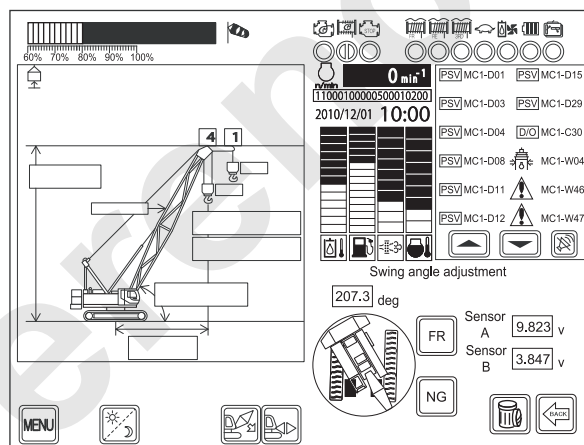

To rest adjusted value, push [A].

"OK" is indicated on both [FR] and [RE] and the value is reset.

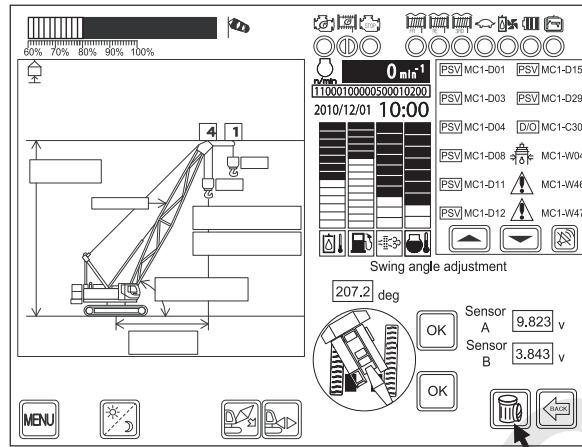

10. ELECTRIC SYSTEM

10.2.11 ML ADJUSTMENT (TEMPORARY)

This adjustment is used to match with the load temporary when error exists in load indication due to load detector abnormality etc.

There is no limit in adjustment value and adjustment would become possible even when error occurs in without load / with load adjustment in "10.2.10 ML ADJUSTMENT (NORMAL)".

However if the crane configuration setting (setting of attachment) is changed, adjusted value would be deleted.

Use this adjustment ONLY for emergency case.

1. Push [ML ADJUSTMENT (TEMPORARY)] in the maintenance menu.

Adjustment possible load detectors become indicated. Select the required one.

Adjustment items become indicated. Select the required one.

The procedure of "WITHOUT LOAD ADJUSTMENT", "WITH LOAD ADJUSTMENT" are same as "WITHOUT LOAD ADJUSTMENT", "WITH LOAD ADJUSTMENT" of "10.2.10 ML ADJUSTMENT (NORMAL)".

(Adjust in the same procedure as P.10-251 to 10-259.)

10.2.12 OPERATION PROGRESS

1. Push [OPERATION PROGRESS] in the maintenance menu.
Information of internal operation indicated.

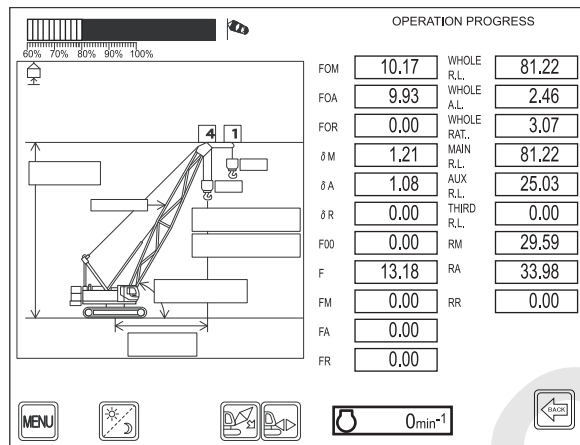

Symbols	Details
FOM	Tare weight component during main winch lifting with current radius
FOA	Tare weight component during aux. winch lifting with current radius
FOR	Tare weight component during third winch lifting with current radius
δM	Load coefficient during main winch lifting with current radius
δA	Load coefficient during aux. winch lifting with current radius
δR	Load coefficient during third winch lifting with current radius
F00	Tare weight component other than weight of hook block with current radius (during simultaneous lifting only) (Not used)
F	Raising guy line tension
FM	Main winch wire rope tension (w/ main winch load cell) (Not used)
FA	Aux. winch wire rope tension (w/ aux. winch load cell) (Not used)
FR	Third winch wire rope tension (w/ third winch load cell) (Not used)
WHOLE R.L.	Whole rated load (rated load during selected mode other than simultaneous lifting mode)
WHOLE A.L.	Whole actual load (actual load during selected mode other than simultaneous lifting mode)
WHOLE RAT.	Whole moment ratio (value indicated in bar graph)
MAIN R.L.	Main winch rated load with current radius on the basis of data
AUX. R.L.	Aux. winch rated load with current radius on the basis of data
THIRD R.L.	Third winch rated load with current radius on the basis of data
RM	Calculated main winch operating radius before correction by radius adjustment
RA	Calculated aux. winch operating radius before correction by radius adjustment
RR	Calculated third winch operating radius before correction by radius adjustment

10. ELECTRIC SYSTEM

EXAMPLE OF USING OPERATION SCREEN

The actual load W can be indicated by the formula shown below.

$$\text{Actual load } W = \frac{F - (FO \times k1 + k2)}{(\delta \times k3 + k4)}$$

Labels for the formula:

- F : Hoist guy line tension
- FO : Dead weight component (M.A.R)
- $k1$: Load-less adjustment value (Span)
- $k2$: Load-less adjustment value (Shift)
- $k3$: Some load adjustment value (Shift)
- $k4$: Some adjustment value (Span)
- δ : Load coefficient (M.A.R)

Suppose the values above are indicated shown below and the indicated actual load is 2 t, when a load weighing 5 t is lifted with the main winch.

$$F = 4.97$$

$$FOM = 2.28$$

$$\delta = 1.33$$

If neither load-less adjustment nor some load adjustment is carried out, and factors from $k1$ to $k4$ are ignored, the theoretical F required for the actual load of 5 t can be found by the using the formula above, as shown below.

$$F = 5 \times 1.33 + 2.28 = 8.93$$

Where, the actual F is obviously smaller than the theoretical F .

Next, the F can be found by the formula shown below.

$$\text{Hoist guy line tension } F = \frac{\text{Load cell rated capacity (depending on the machine models)} \times 5 \times (\text{present load cell voltage} - \text{load cell zero adjustment value})}{(\text{Load cell rated voltage} - \text{load cell zero adjustment value}) \times 0.08333 \times (1.02 \text{ or } 0.98)}$$

Labels for the formula:

- Load cell rated capacity (depending on the machine models)
- present load cell voltage
- load cell zero adjustment value
- Load cell rated voltage
- 1/reaving rope coefficient (depending on the machine models)
- Correction coefficient for lowering (depending on the machine models)
- Correction coefficient for raising (depending on the machine models)

10.2.13 VERSION INFORMATION

1. Push [VERSION INFORMATION] in the maintenance menu.

Each part number and version of ML program, monitor, MC1 program, MC2 program, ML data are indicated.

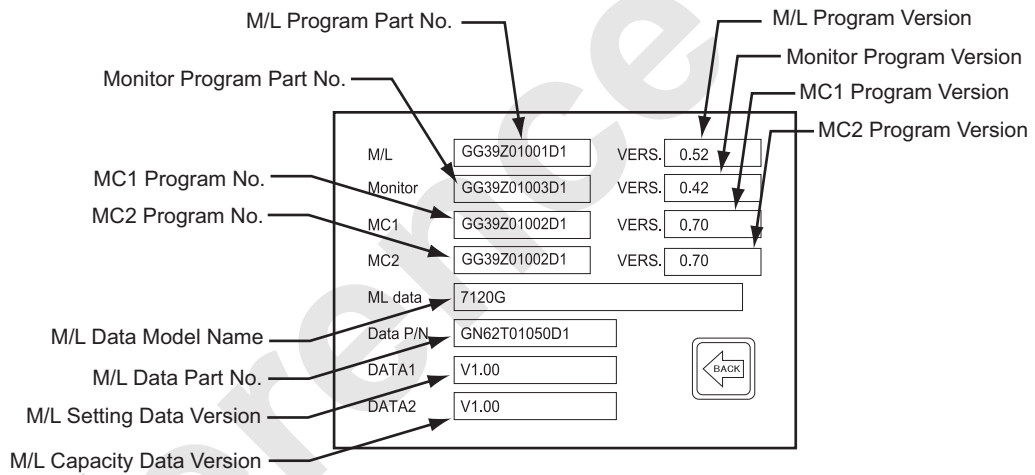
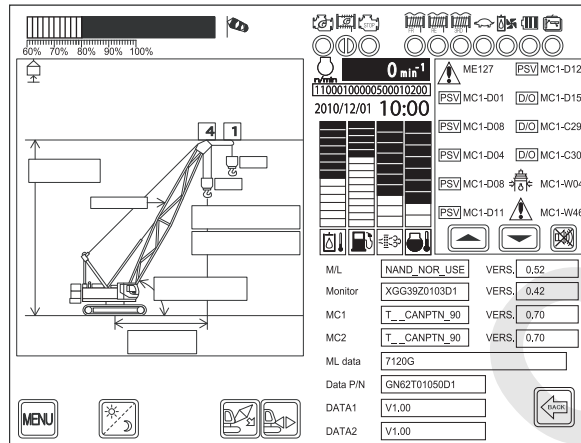

10. ELECTRIC SYSTEM

10.2.14 FAILURE HISTORY

1. Push [FAILURE HISTORY] in the maintenance menu.
2. Items are indicated.

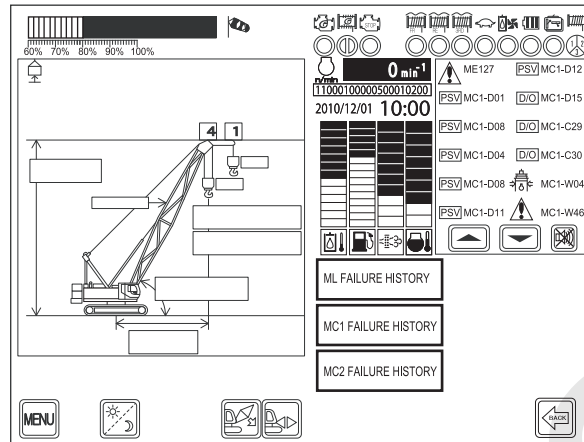

(1) ML FAILURE HISTORY

Push [ML FAILURE HISTORY] in the menu.

Past failures become indicated from latest one in order to max. 20 items.

Failure content is indicated by code.

Check the contents by the table in operator's manual "3.13 MESSAGE TABLE".

The screenshot shows the 'ML FAILURE HISTORY' screen. It features the same schematic diagram on the left. On the right is a table with two columns: 'No.' and 'DATE'. Below the table are 'MENU' and 'BACK' buttons. An arrow labeled 'A' points to a button with a printer icon.

No.	DATE
110	2011.01.20. 19:36
110	2011.01.20. 19:34
110	2011.01.20. 19:22
110	2011.01.20. 19:21
110	2011.01.20. 19:20
110	2011.01.20. 19:19
110	2011.01.20. 19:19
110	2011.01.20. 19:14
110	2011.01.20. 18:52
113	2011.01.18. 14:22
112	2011.01.18. 14:22
113	2011.01.18. 14:21
112	2011.01.18. 14:21
110	2011.01.14. 18:59
121	2011.01.13. 15:28
103	2011.01.13. 15:28
0	2000.00.00. 00:00
0	2000.00.00. 00:00
0	2000.00.00. 00:00
0	2000.00.00. 00:00

A

10. ELECTRIC SYSTEM

(2) MC1 FAILURE HISTORY

Push [MC1 FAILURE HISTORY] in the menu.

Past failures become indicated from the latest one in order to max. 200 items (10 item X 20 page).

By [A] page can be scrolled up and by [B] page can be scrolled down.

Failure content is indicated by code.

Check the contents by the table in operator's manual "3.13 MESSAGE TABLE".

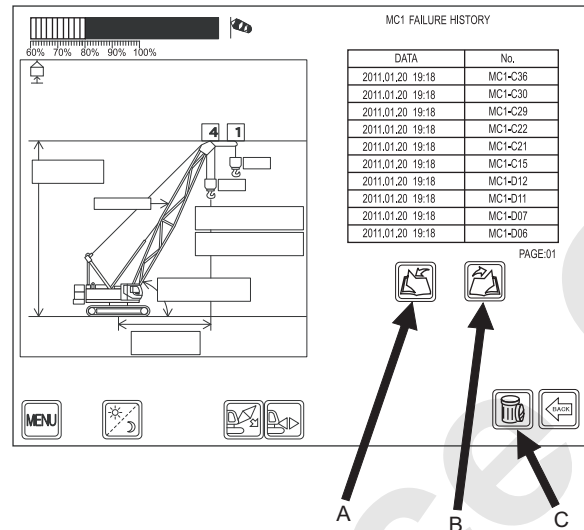

DELETING FAILURE HISTORY

To delete failure history, push [C].

Message below becomes indicated.

By pushing [GO], data is deleted.

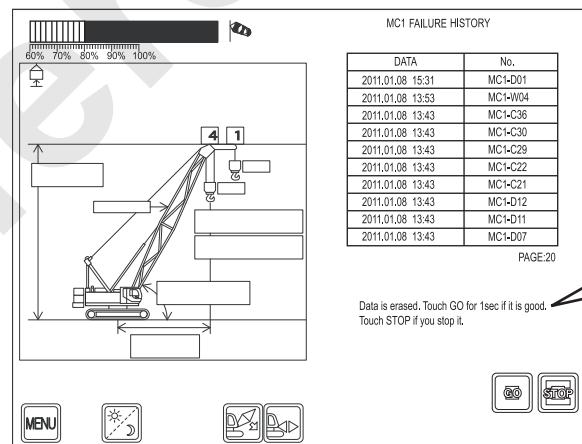

Data is erased.
Touch GO for 1sec if it is good.
Touch STOP if you stop it.

In case of deletion, push [GO]. In case of stop, push [STOP].

If deleted, all pages are deleted at once. Push [GO] for more than 1 second.

By pushing [GO], data is deleted.

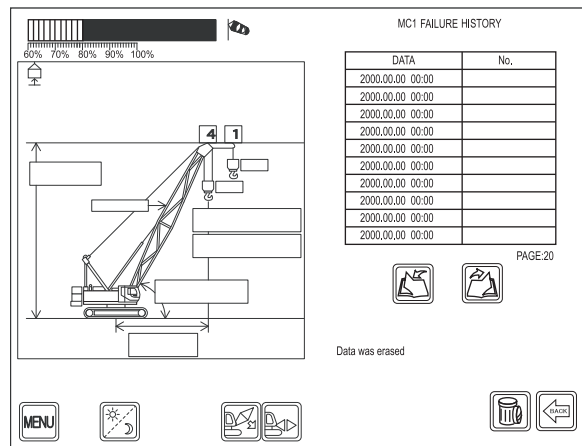

(3) DELETING MC2 FAILURE HISTORY

Push [DELETING MC2 FAILURE HISTORY] in the menu.

Indication content and handling procedure are same as MC1.

10. ELECTRIC SYSTEM

10.2.15 ADJUSTMENT DATA

1. Push [ADJUSTMENT DATA] in the maintenance menu.
Adjustment data menu becomes indicated.

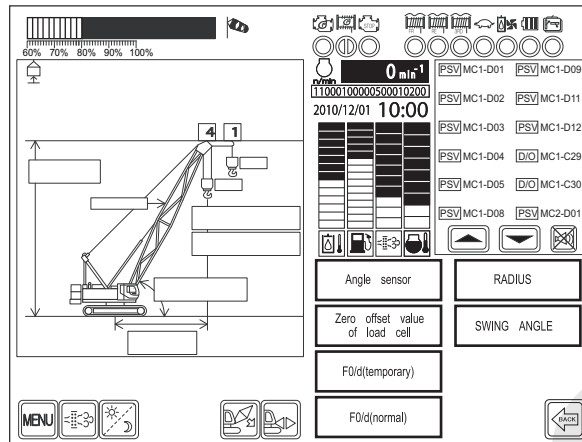

(1) ANGLE SENSOR

(A) ADJUSTMENT DATA INDICATION

- Push [ANGLE SENSOR] in the menu.
Table of adjustment data of angle detector is indicated.

On this machine, No.1 is used for boom angle detector, No.2 is for tower jib angle detector and No.3 is for tower jib angle detector.

If adjustment is not done yet, shift = 0.000, span = 1.000 is indicated.

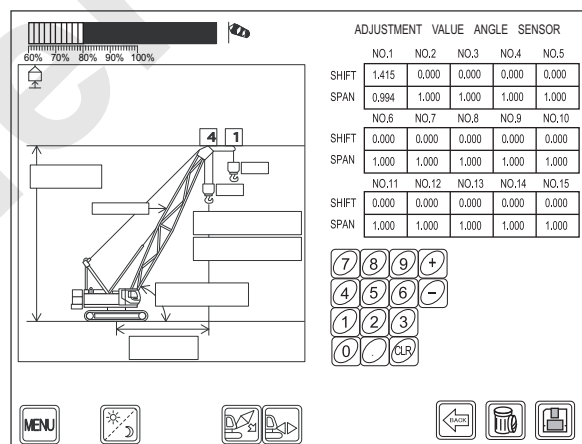

(B) ADJUSTMENT DATA CHANGE

In case of changing adjustment data, touch the digit area to be changed.
 Touched area becomes reverse indication and digit input becomes possible.

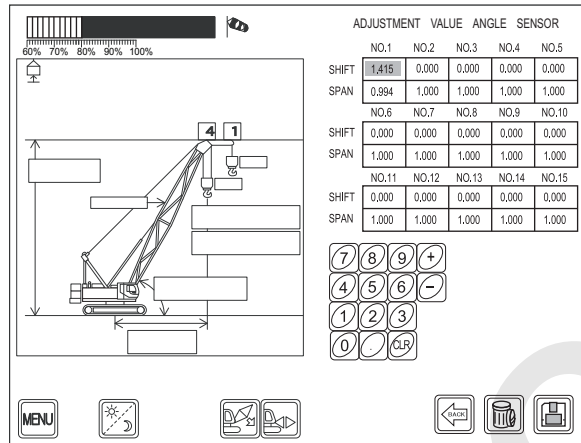

Input digit with digit key.
 In case of input [1.103], input [1], [.] , [1], [0], [3].
 If there is other changing area, change the digit in the same way.
 After all input is completed, push [A].

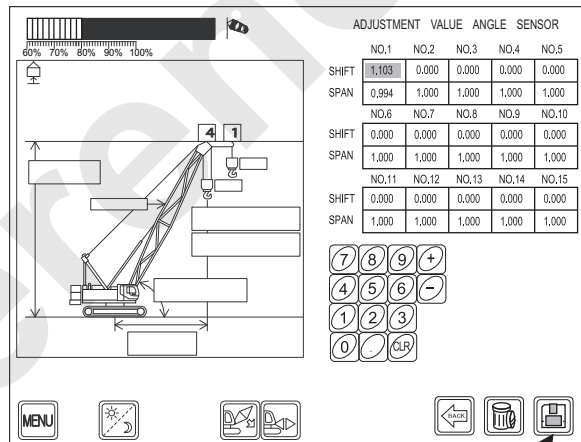

A

10. ELECTRIC SYSTEM

The message below becomes indicated.

Push [OK].

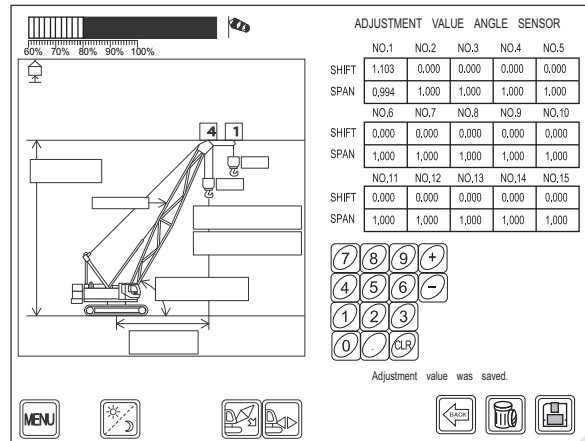

(C) DELETING ADJUSTMENT DATA

All of adjustment datas are returned to initial values.

Push [B] for 3 seconds to execute.

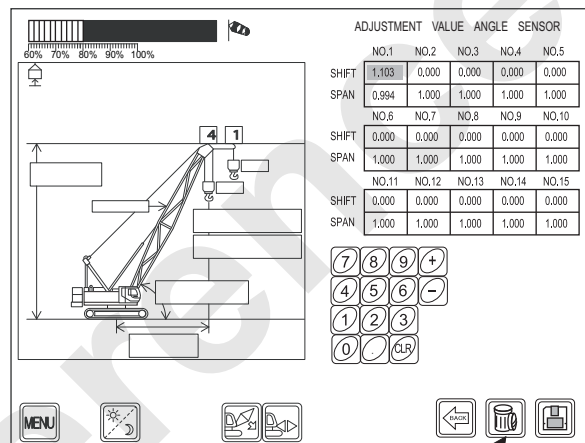

B

All adjustment data returns to the initial value.

Initial value :

Shift = 0.000, Span = 1.000

This is to complete deletion.

Push [OK].

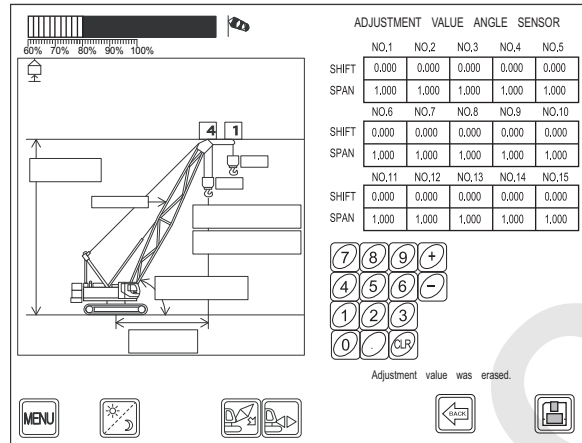

Reference Only

10. ELECTRIC SYSTEM

(2) LOAD DETECTOR ZERO ADJUSTMENT

(A) ADJUSTMENT DATA INDICATION

Push [Zero offset value of load cell] in the menu.

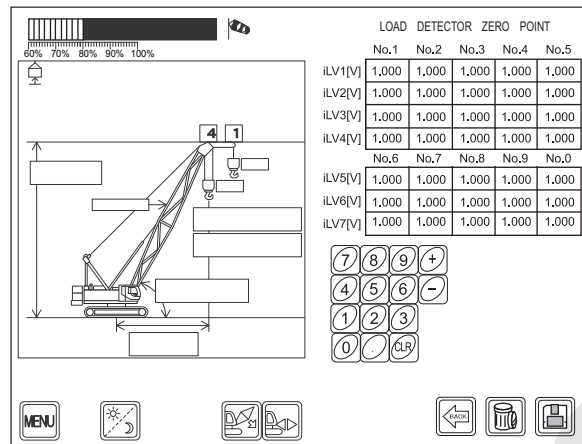

Table of zero point adjustment data of load detector is indicated.

They are indicated by load cell voltage value at time of zero adjustment.

On this machine, No.1 of iL1 is used for boom hoist load detector, No.1 of iL3 is for jib hoist load detector.

If adjustment is not done yet, 1.000 is indicated.

Push [BACK] to return to the previous screen.

(B) CHANGING OF ADJUSTMENT DATA

(C) DELETION OF ADJUSTMENT DATA

Adjustment data can be changed or deleted with the same way as that of adjustment data of angle detectors.

(3) WITHOUT LOAD / WITH LOAD
(TEMPORARY)

(A) ADJUSTMENT DATA INDICATION

Push [F0/d (temporary)] in the menu.

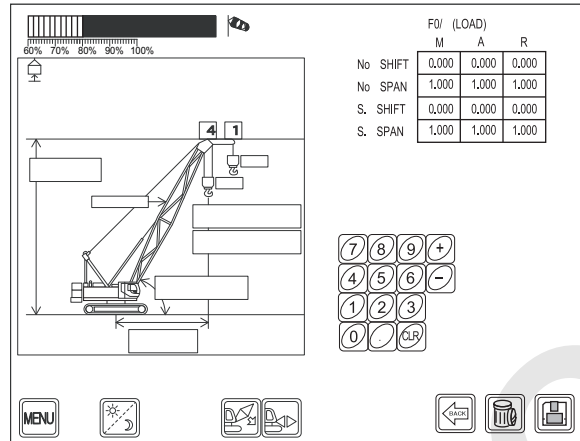

Table of adjustment datas becomes indicated.

M : Front lifting mode adjustment data

A : Rear lifting mode adjustment data

R : Third lifting mode adjustment data

No. : Without load adjustment

S. : With load adjustment

If adjustment is not done yet, shift = 0.000, span = 1.000 becomes indicated.

To return to previous screen, push [BACK].

(B) CHANGING OF ADJUSTMENT DATA

(C) DELETION OF ADJUSTMENT DATA

Adjustment data can be changed or deleted with the same way as that of adjustment data of angle detectors.

10. ELECTRIC SYSTEM

(4) WITHOUT LOAD / WITH LOAD (NORMAL)

(A) ADJUSTMENT DATA INDICATION

Push [F0/d (normal)] in the menu.

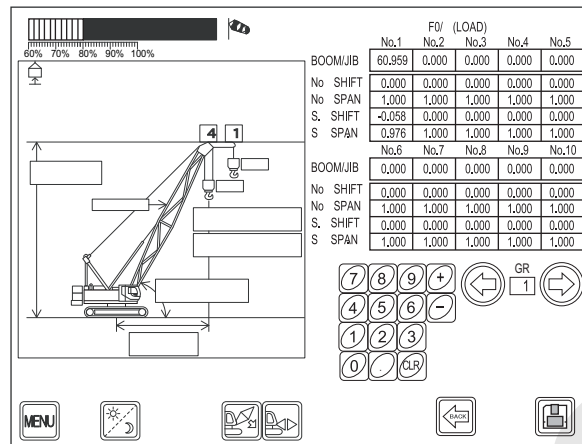

Table of adjustment data becomes indicated.

On this adjustment, 10 type of boom length adjustment are possible on each group of 1 to 30.

At first, group 1 becomes indicated.

On every pushing of [→], group changes like 2, 3, 4.....30.

On every pushing of [←], group changes like 30, 29, 28.....2.

No.1 to No.10, adjusted boom length (jib length in case of luffing), shift and span of without load adjusting become indicated.

If adjustment is not done yet, shift = 0.000, span = 1.000 becomes indicated. When more than two boom (jib) length are adjusted and non adjusted boom (jib) length is used, calibration between closest two length is applied.

(B) CHANGING OF ADJUSTMENT DATA

(C) DELETION OF ADJUSTMENT DATA

Adjustment data can be changed or deleted with the same way as that of adjustment data of angle detectors.

* In case of deletion, indicated group data ONLY are deleted.

(5) SWING RADIUS

(A) ADJUSTMENT DATA INDICATION

Push [RADIUS] in the menu.

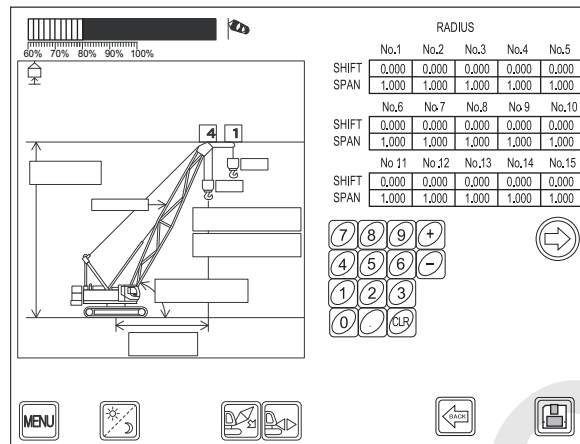

Table of adjustment datas becomes indicated.

This adjustment also consists of group 1 to 30 and the first screen indicates group 16 to 30.

By pushing [→] group 16 to 30 becomes indicated.

Contents of each group is as same as that of "WITHOUT LOAD / WITH LOAD (NORMAL)".

If adjustment is not done yet, shift = 0.000, span = 1.000 becomes indicated.

(B) CHANGING OF ADJUSTMENT DATA

(C) DELETION OF ADJUSTMENT DATA

Adjustment data can be changed or deleted with the same way as that of adjustment data of angle detectors.

10. ELECTRIC SYSTEM

10.2.16 DOWNLOAD ML PROGRAM

1. Take out data CF card from ML controller and insert CF card with new program filed in.
* It is possible to write in by filing the program to data CF card.
E Model will be need turn on to "H3" position of drum select switch.
2. Connect write in permit connector CN- 420M on the right upper of the controller and CN-439F.
3. Turn on the key switch.
4. Download is started.

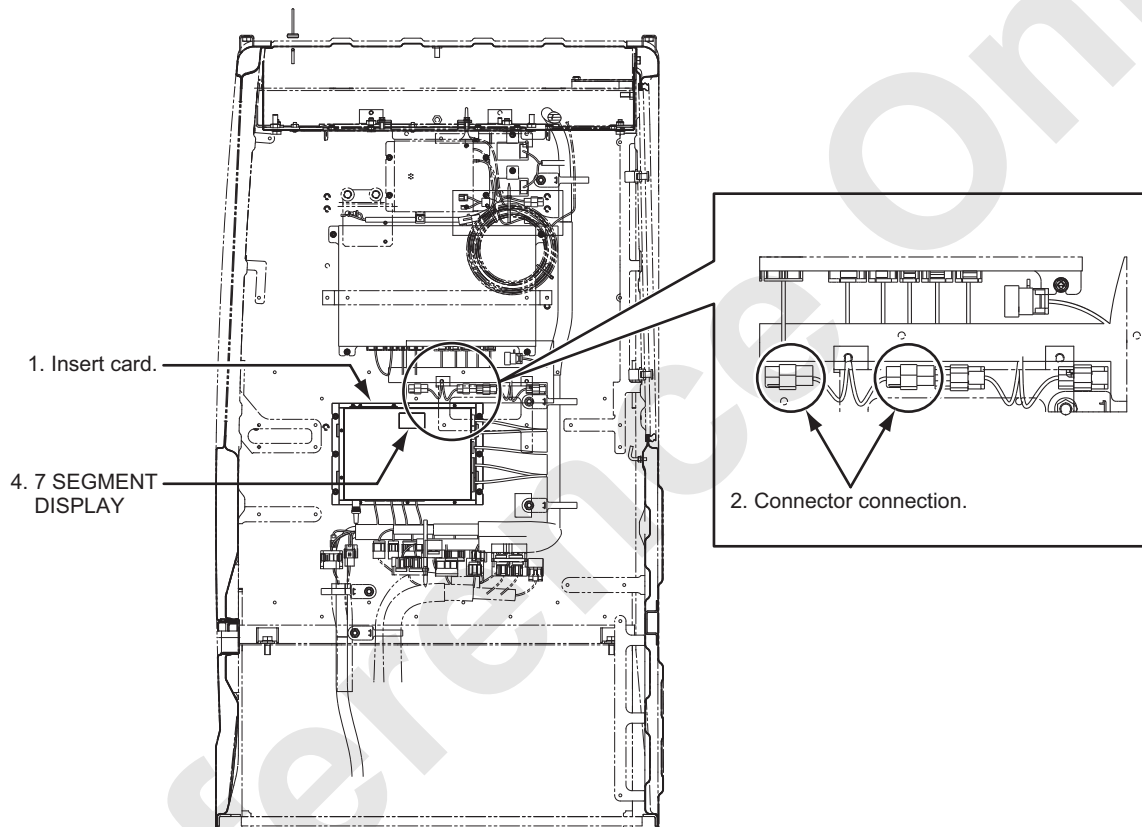

During download, 7 segment display of the controller changes as shown below.

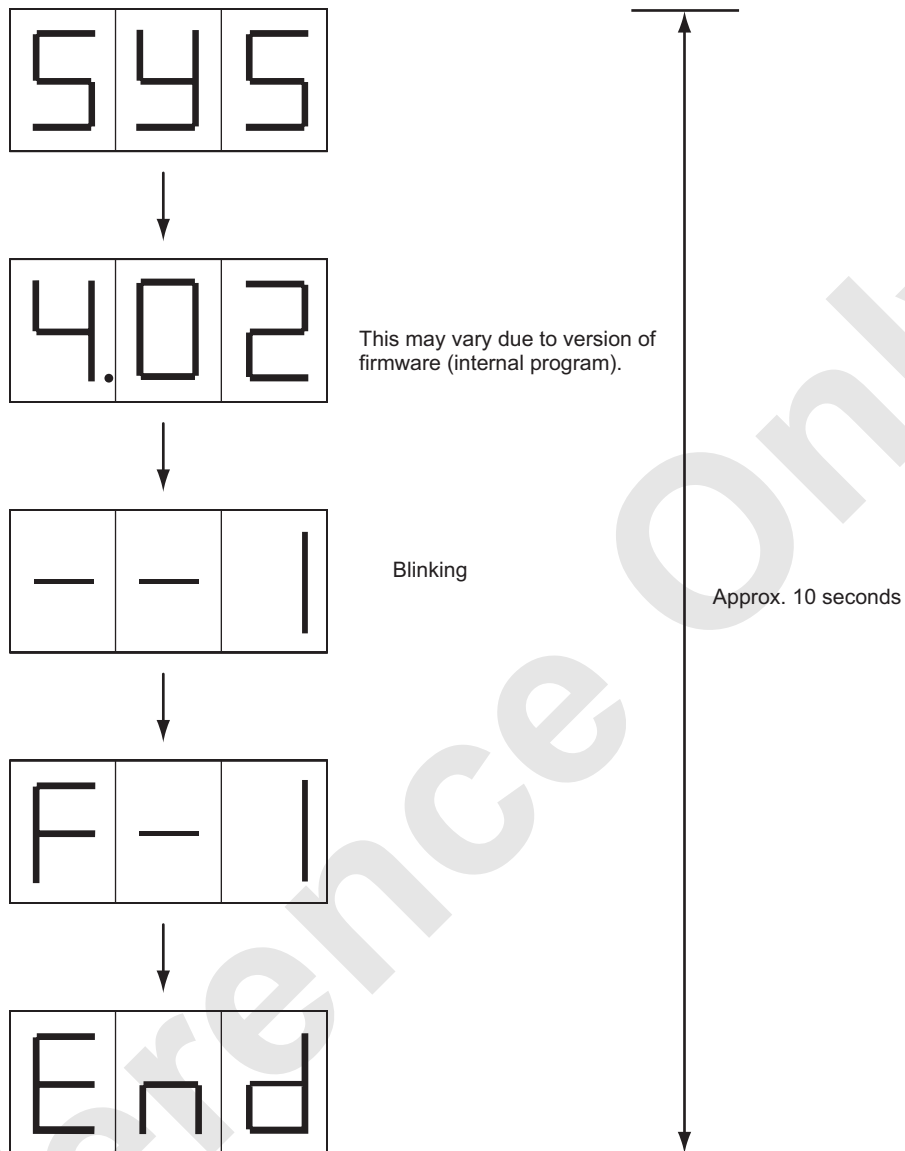

5. When End is indicated, re-writing is completed.
6. Turn OFF the key switch.
7. Pull out write in permit connector.
8. Return the CF card back to the original position.

10. ELECTRIC SYSTEM

10.2.17 DOWNLOAD OF MONITOR PROGRAM

1. Insert the CF card with new program filed in to the CF card throttle on the back face of the monitor.
 - * Ensure to close the cover.

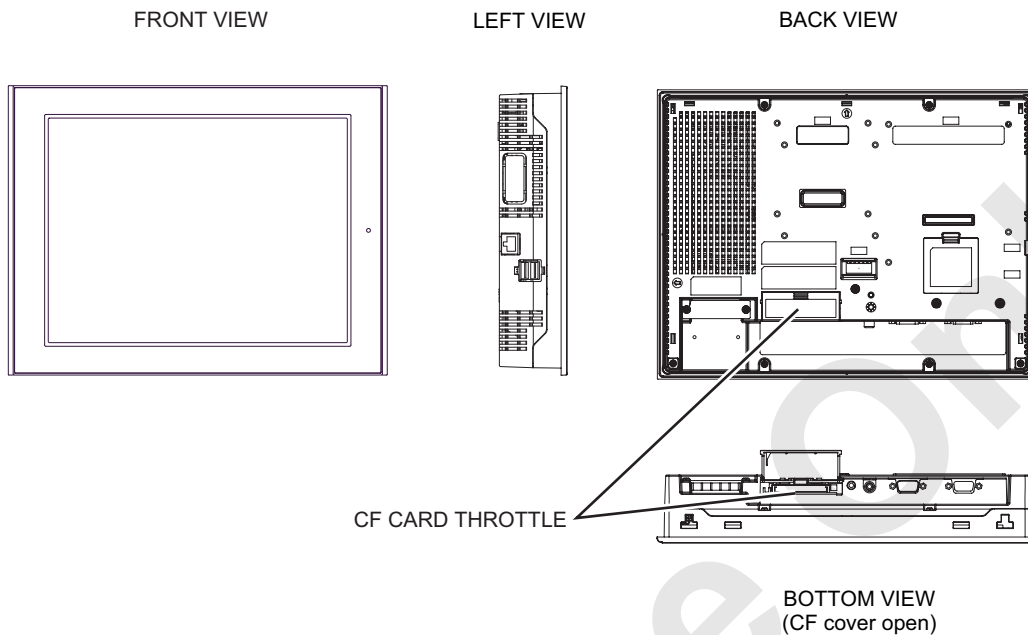

2. Turn the key switch ON and wait for screen to start.
3. When the screen is started, tap on screen corners diagonally in succession.

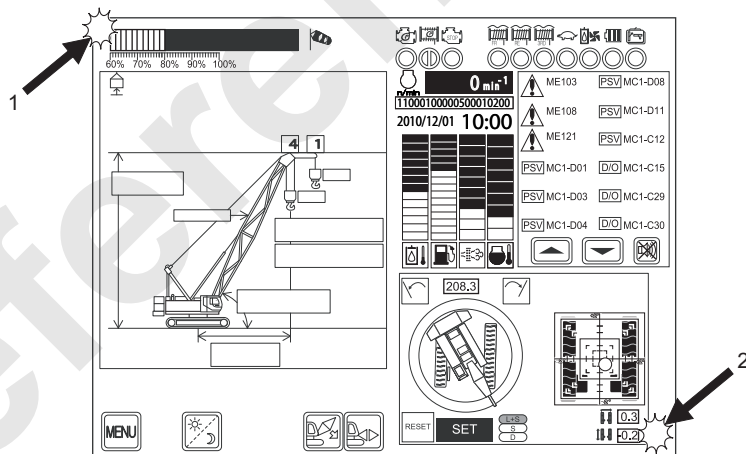

4. Menu becomes indicated on the lower part of the screen. Select [CF/USB].

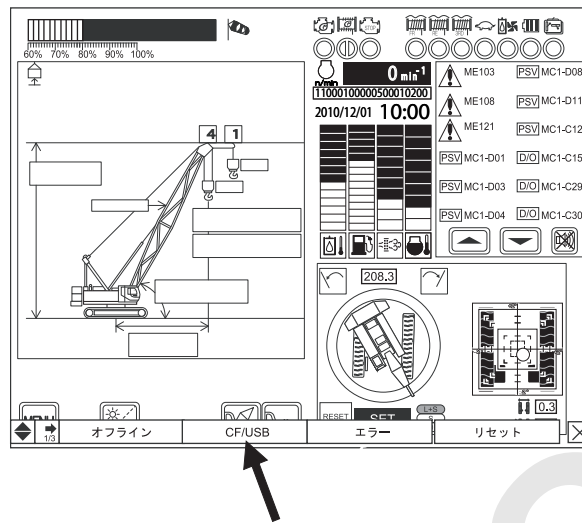

5. Select [CF START].

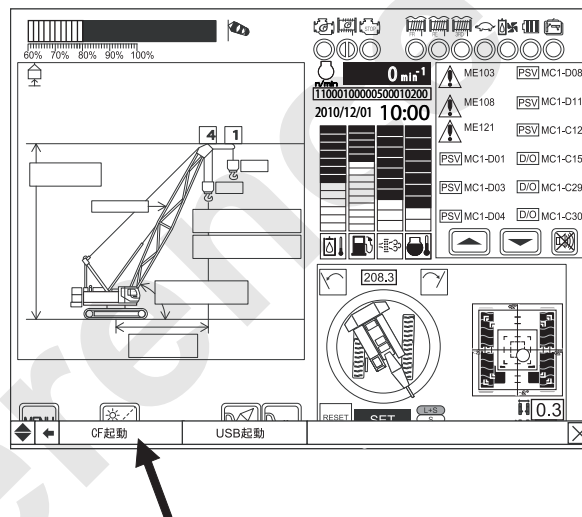

10. ELECTRIC SYSTEM

6. If the error as shown below is indicated, check for inserted condition of CF card or cover to be closed.

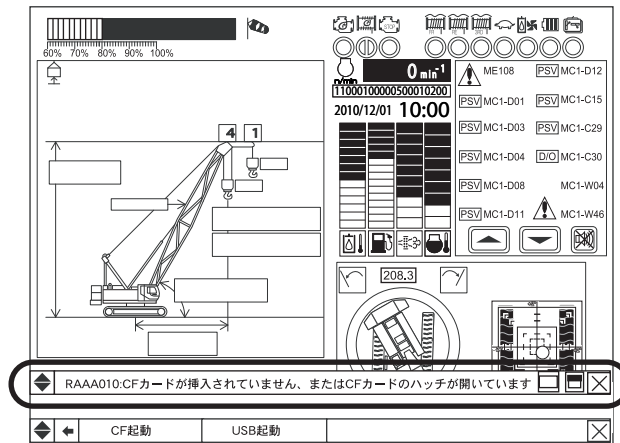

7. Select [DOWNLOAD (CF → Display)]

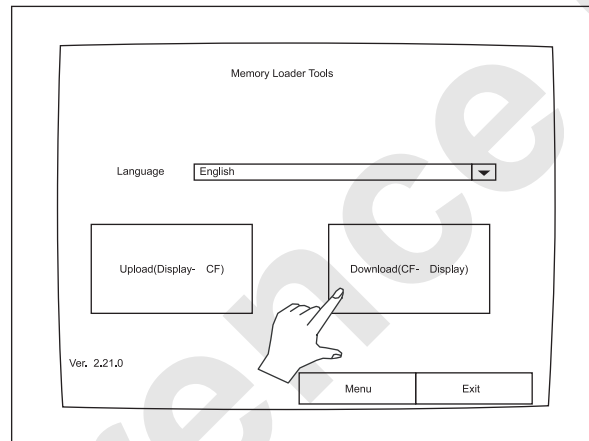

8. Select [START].

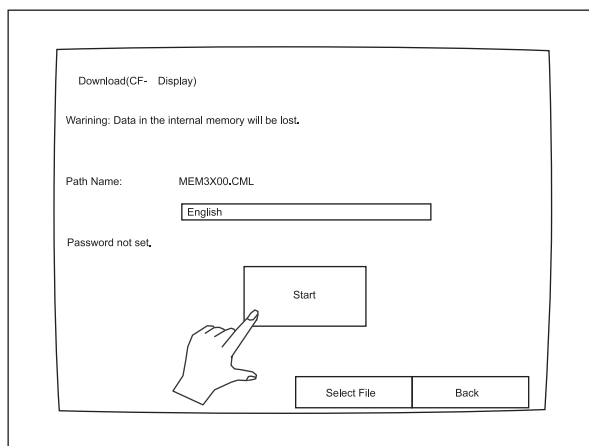

9. Select [YES].

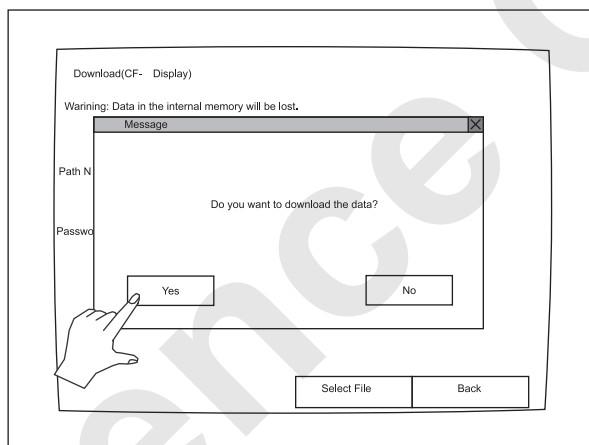

10. ELECTRIC SYSTEM

10. Download starts.

Write in [OS data], [System / Project data] in its order. If properly completed, message as shown below becomes indicated.

Push [Back].

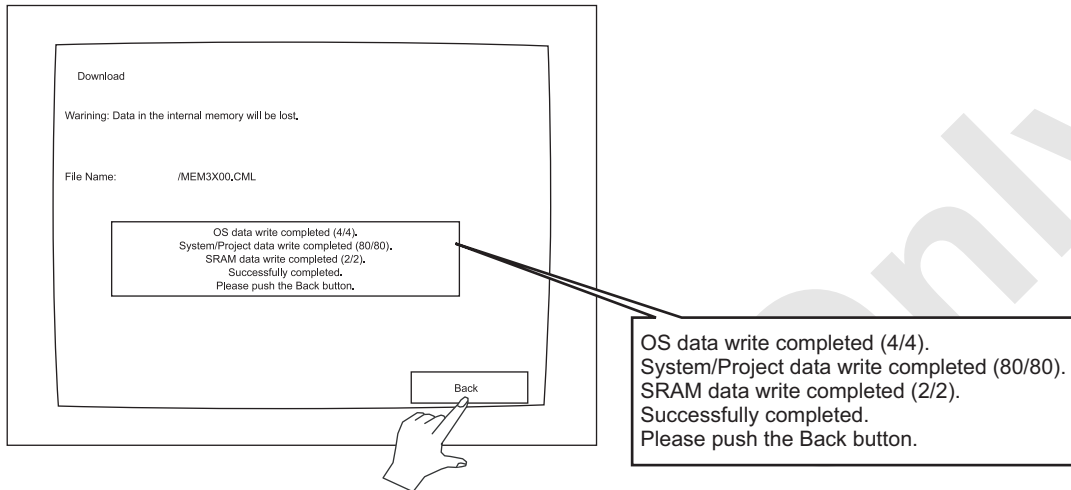

11. Push [Back] to return to the screen before writing in starts.

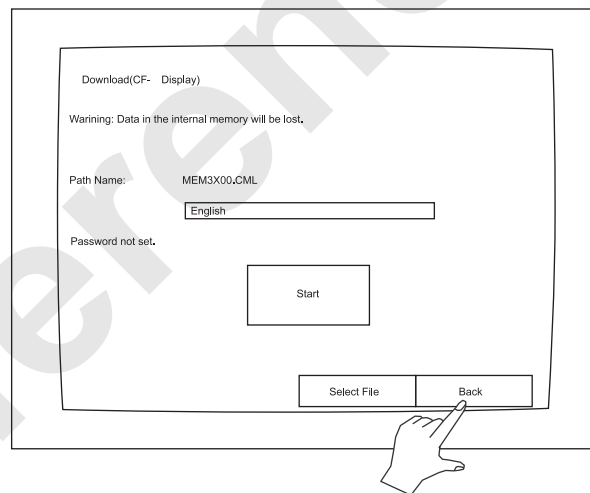

12. Push [Exit] to return to the screen 1 step before.

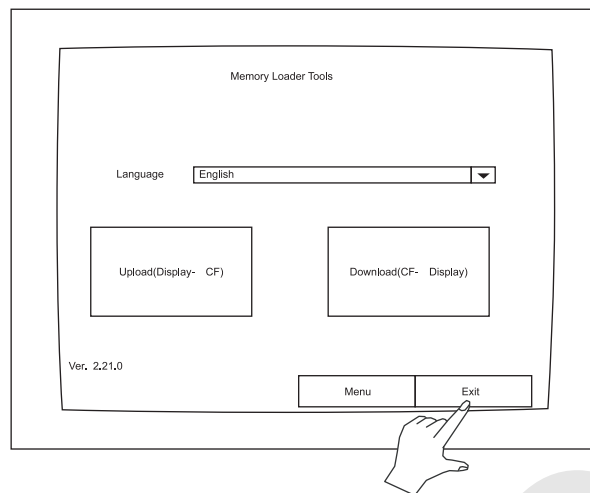

13. Push [Yes].

Monitor re-starts.

This is to complete re-writing of program.

Turn the key switch OFF and take out the CF card.

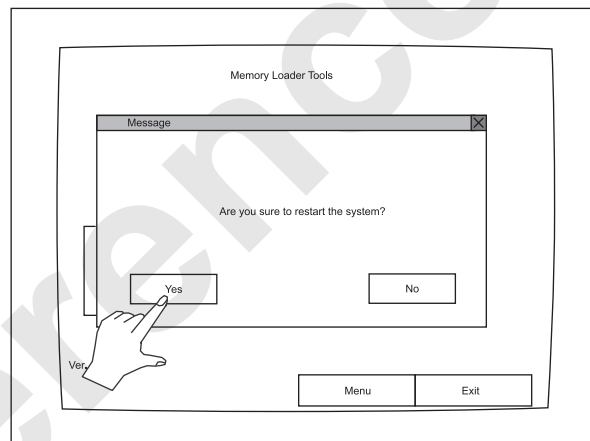

10.3 MAIN CONTROLLER

10.3.1 ARRANGEMENT OF MAIN CONTROLLER

1. INSTALLATION POSITION (CAB) OF MAIN CONTROLLER 1

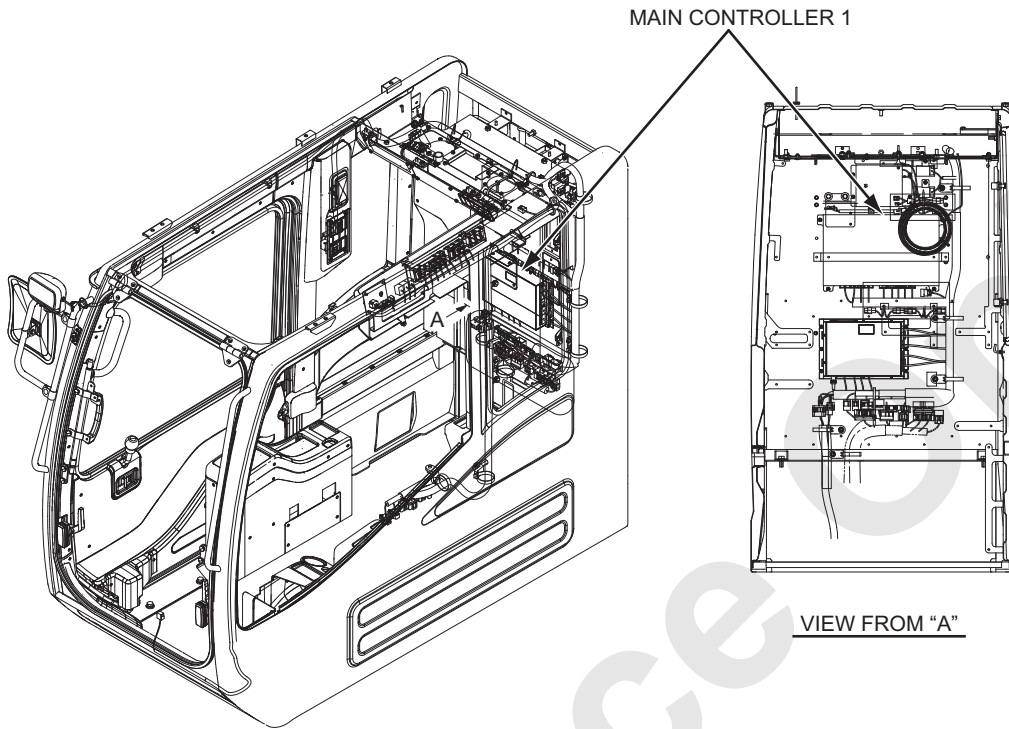

2. INSTALLATION POSITION (LEFT CAB) OF MAIN CONTROLLER 2

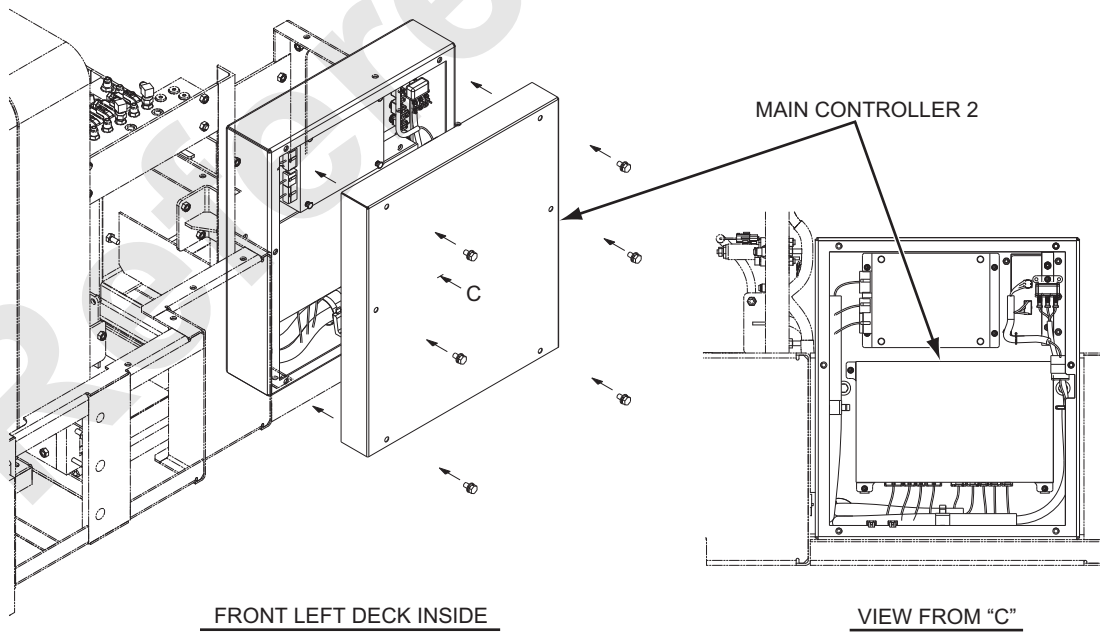

10.3.2 COMPOSITION OF SYSTEM

1. SYSTEM COMPOSITION CHART

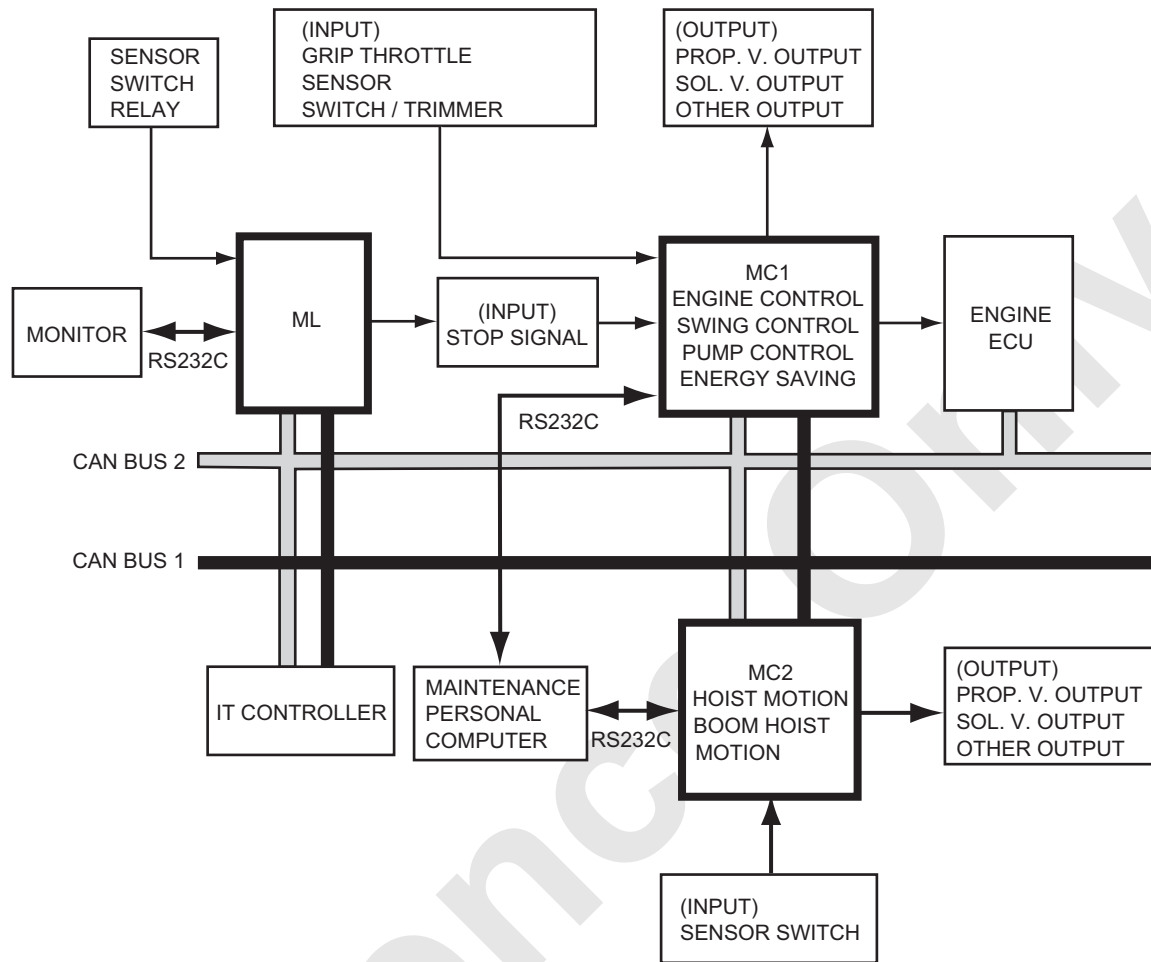

- Output relation to controller

Items	Input/Output	Signal types	Outline
M/L (LMI)	Input/Output	Serial communication	The changes in lifting height during boom and jib hoisting, faults signals, and number of part lines are transmitted from the M/L. The operating direction of the winch operation lever is transmitted to the M/L. The signals referring to automatic stop are input from the M/L in digital form.
Maintenance personal computer	Input/Output	Serial communication	This PC is used for down-loading of programs.
Grip throttle	Input	Analogue 0 to 5 V	The grip signals from the engine throttle are input.
Sensor	Input		The values from the pressure sensor, engine turn sensor, wind speed sensor, etc. are input.
Cab inside switch/trimmer	Input		The values from the switches and trimmers in the cab are input.
Proportional valve	Output	24 V 100 to 700 mA	PWM output Constant current circuit (Max 1 A) Disconnection detection W/short-circuit protection
Solenoid valve	Output	24 V 1 A	Disconnection detection W/short-circuit protection

10. ELECTRIC SYSTEM

10.3.3 FUNCTION OF MAIN CONTROLLER

No.	FUNCTION	CONTROL	
		MC1	MC2
1	ACCELERATOR CONTROL	○	
2	HORSE POWER CONTROL	○	
3	WINCH MOTOR SPEED CONTROL	○	○
4	-		
5	SWING COUNTERFORCE	○	
6	SWING SPEED CONTROL	○	
7	SWING AUTO STOP	○	
8	WINCH CONTROL	○	○
9	BOOST CONTROL		○
10	BOOM STOP CONTROL		○
11	-		
12	-		
13	FRONT/REAR HOIST STOP		○
14	MOTOR TILT ANGLE CONTROL		○
15	HOOK OVER HOIST CONTROL	○	○
16	DRUM ROTATION DETECT GRIP CONTROL	○	
17	FRONT/BOOM PUMP CONTROL	○	
18	HEIGHT METER	○	
19	LEVER INTERLOCK CONTROL	○	○
20	DPF REGENERATION CONTROL	○	○
21	-		
22	G WINCH CONTROL		○
23	G ENGINE CONTROL	○	
24	AIS CONTROL	○	
25	HYD. OIL HEAT	○	○

MC1 : MAIN CONTROLLER 1
MC2 : MAIN CONTROLLER 2

- Adjustment function

No.	Function items
1	Adjustment 1 Model number setting
2	Adjustment 2 Option setting
3	Adjustment 3 Adjustment of grip throttle and foot throttle
4	Adjustment 4 Engine speed adjustment
5	Adjustment 5 Adjusting of inclination meter
6	Adjustment 6 Supply pump adjustment

1. ACCELERATOR CONTROL

(1) Accelerator control

This provides command to ECU (engine control) based on input of grip throttle or foot throttle. In case of both throttles are equipped, throttle having larger amount of command has priority.

To make foot throttle effective, option setting and adjustment is required.

In case of receiving command from remote control too, accelerator control by command to ECU shall be done.

In case the remote control is connected, input to remote control has the first priority to control.

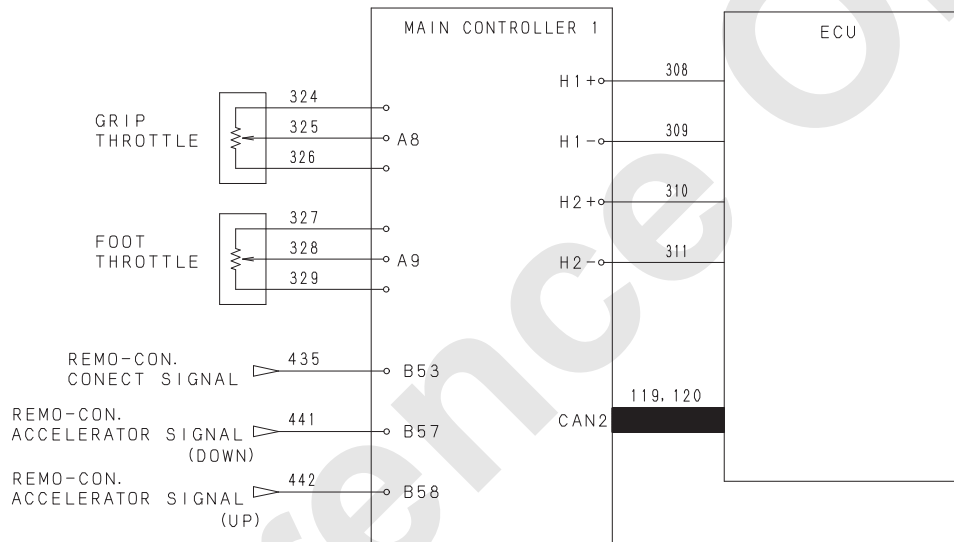

If the wire of accelerator control or foot control is broken, output voltage to ECU becomes 0 V.)

In this case, by turning the aux. accelerator switch to ON, low speed and middle speed becomes operational.

(High speed is not possible)

10. ELECTRIC SYSTEM

(2) Power control

Battery is energized 1.5 seconds after the key switch is turned ON.

Battery is de-energized 4 seconds *after the key switch is turned OFF.

However in case of emergency solenoid being actuated, 90 seconds after.

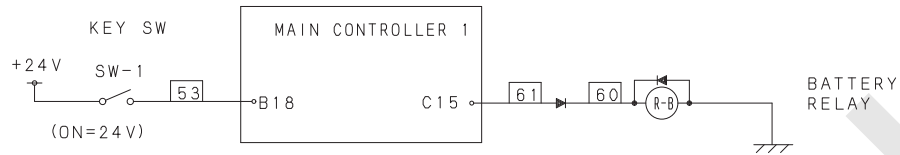

2. HORSE POWER CONTROL

This is to control pump by calculating target speed from grip throttle and by matching with engine actual speed.

Lower the actual speed is against target speed, larger the output current is.

However in case of low idling, even the difference is small, output current is large.

(to prevent engine stall)

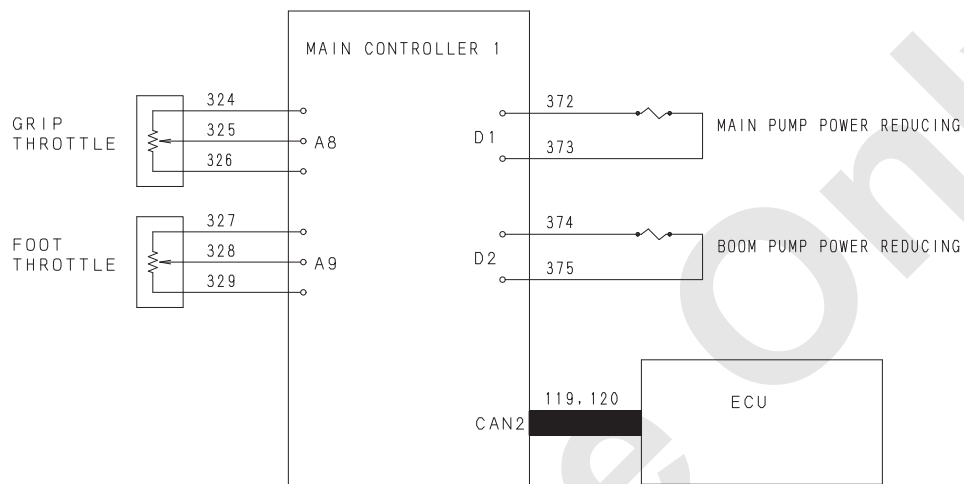

10. ELECTRIC SYSTEM

3. WINCH MOTOR SPEED CONTROL

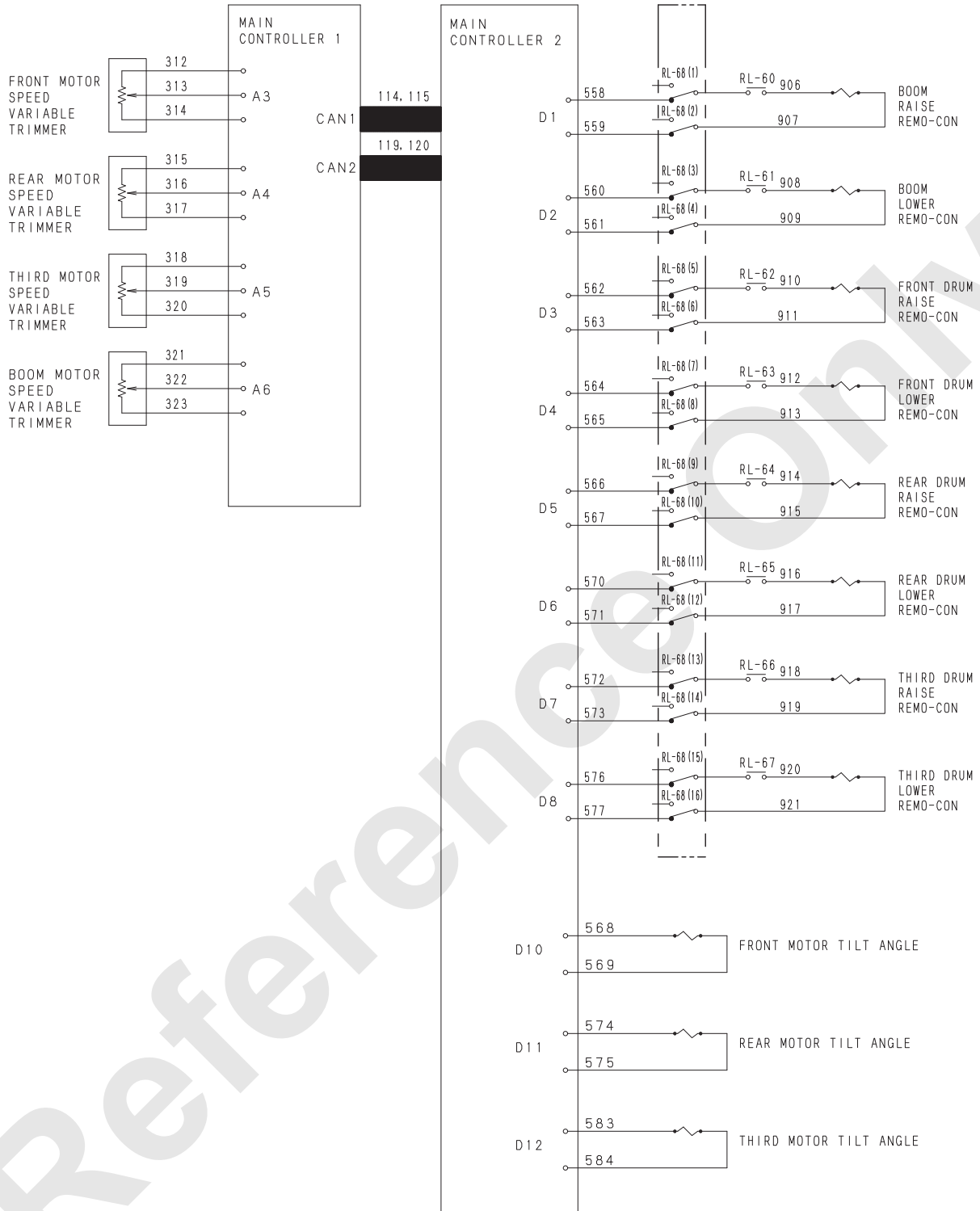

- (1) Front/Rear/Third (option) drum speed variable
 Max. current of remo-con prop. valve and motor control prop. valve is controlled as shown above.

Priority order is as follows.

Remo-con prop. valve

Front, rear, third (option) stop, Lever interlock >
 Front, rear speed reducing > Free fall > Trimmer control

Motor control prop. valve

(Refer to "14. MOTOR TILT ANGLE CONTROL" for detail)

Auto-stop > Free fall speed increase > Main pump inching speed > Trimmer control (during power lowering)

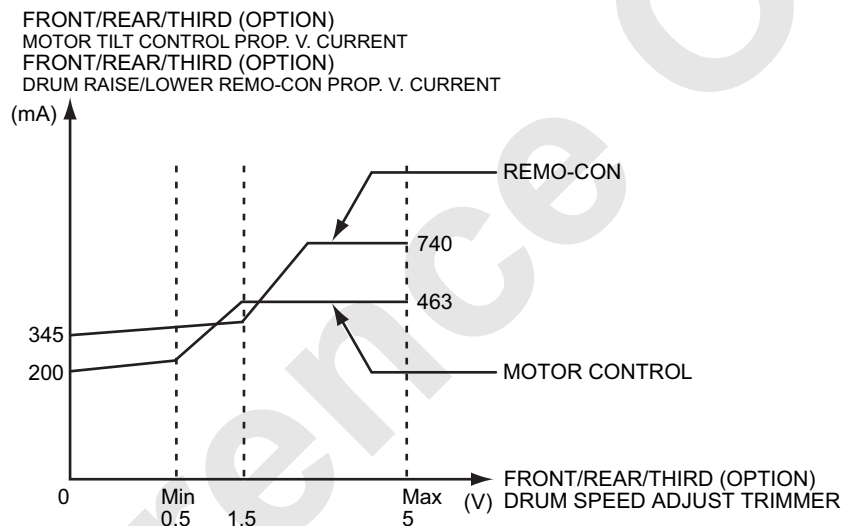

10. ELECTRIC SYSTEM

(2) Boom drum speed control

In case of low engine speed, when engine speed is intended to raise by characteristic (a), it becomes closer to characteristic (b).

If the trimmer is set to maximum value, the prop. valve becomes full open and the main valve opening becomes maximum.

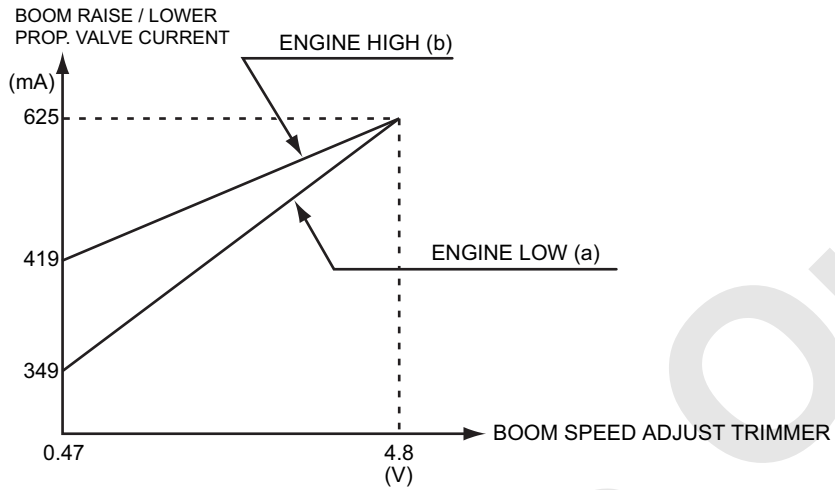

5. SWING COUNTERFORCE

A reaction is applied to the lever depending on swing loads.

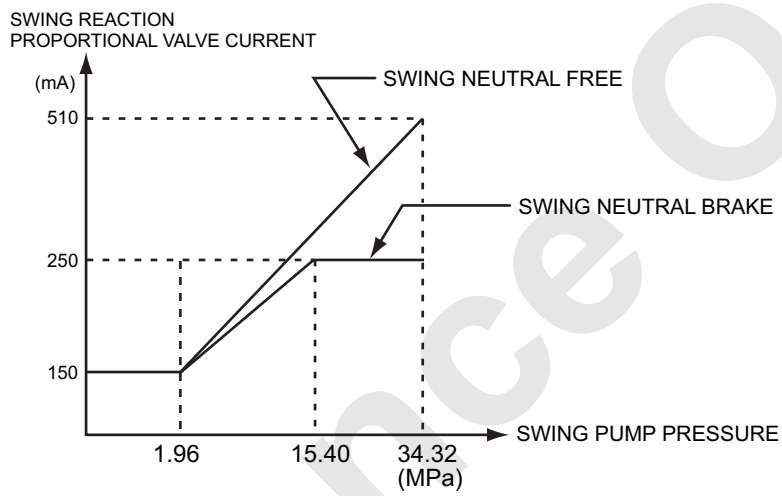
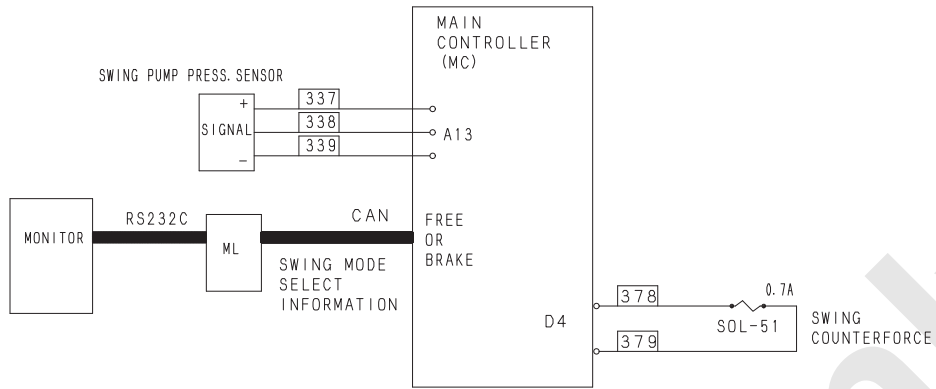

10. ELECTRIC SYSTEM

6. SWING SPEED CONTROL

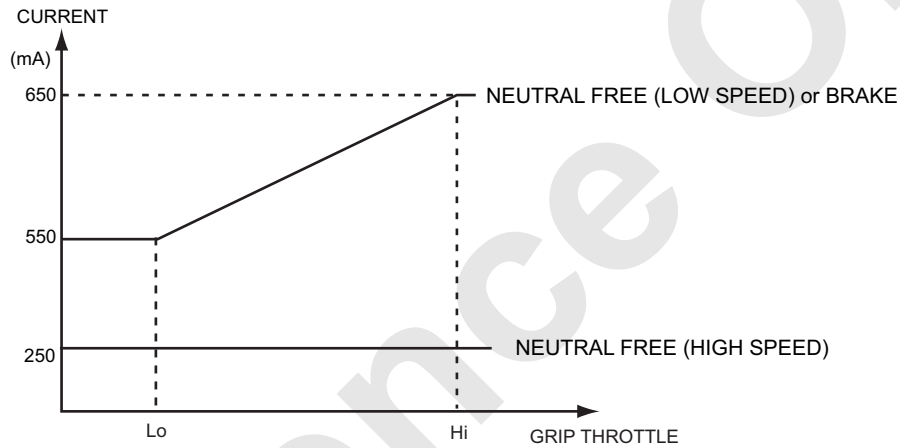
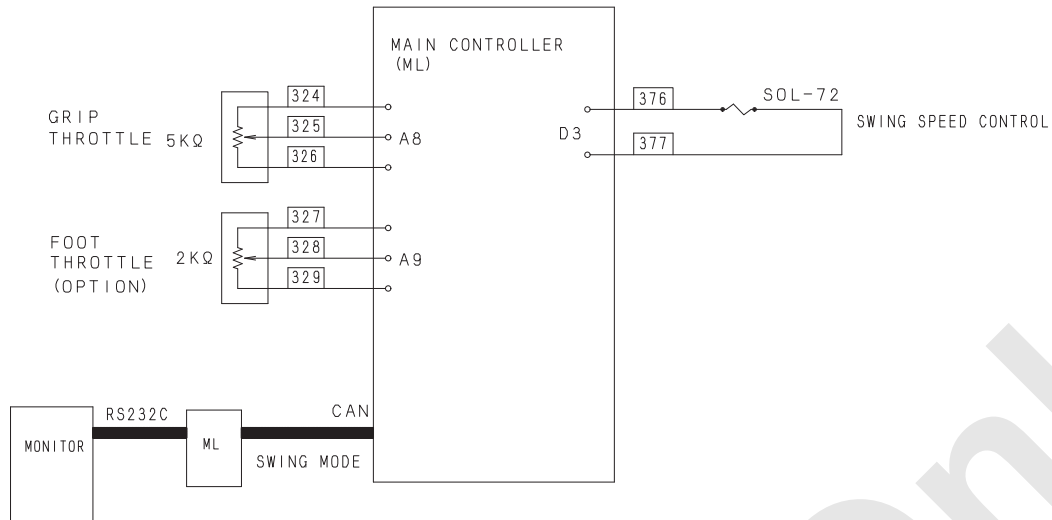

- When the swing control signal is OFF for 10 seconds, or swing limit function is selected, the current becomes maximum value. (700 mA)

7. SWING LIMIT CONTROL

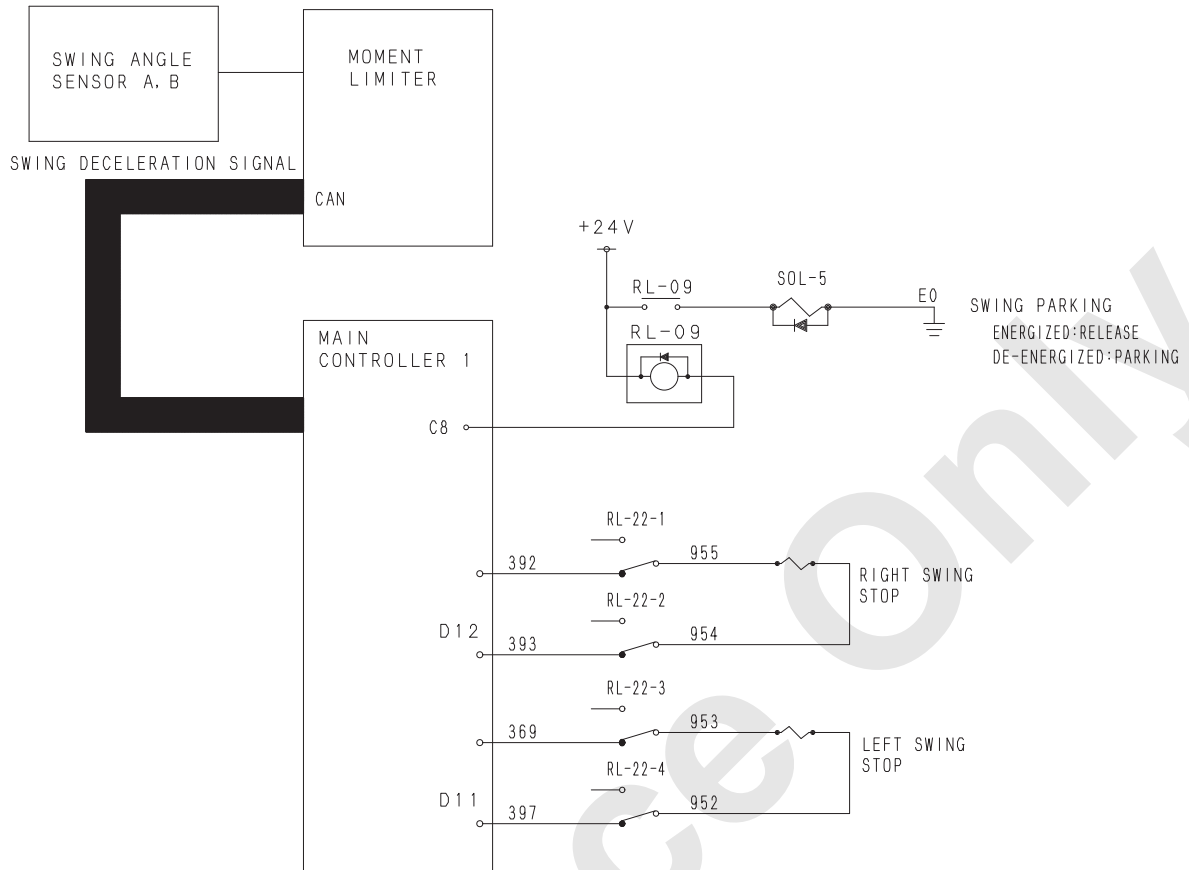

(1) Swing deceleration

Based on swing deceleration signal (R and L) input value (31 → 0), right swing / left swing stop prop. valve output current is controlled.

(2) Swing stop

5 seconds after the deceleration signal becomes "0", swing parking output is issued.

Parking action is released when left control pressure is detected when stopped with right deceleration.

Parking action is released when right control pressure is detected when stopped with left deceleration.

Judging point of control pressure is more than 0.539 MPa.

Swing stop prop. valve (R and L)

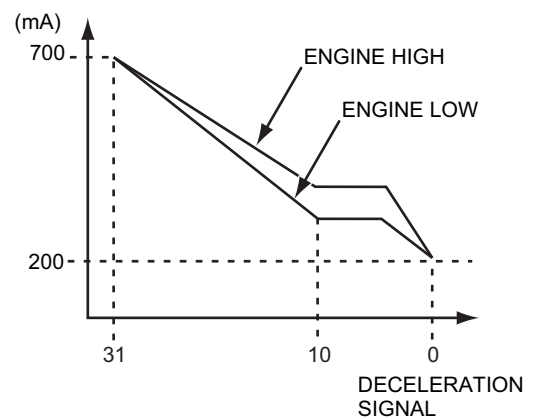

10. ELECTRIC SYSTEM

8. WINCH CONTROL

- (1) Control lever neutral mode selection
- (2) Winch operation solenoid valve control

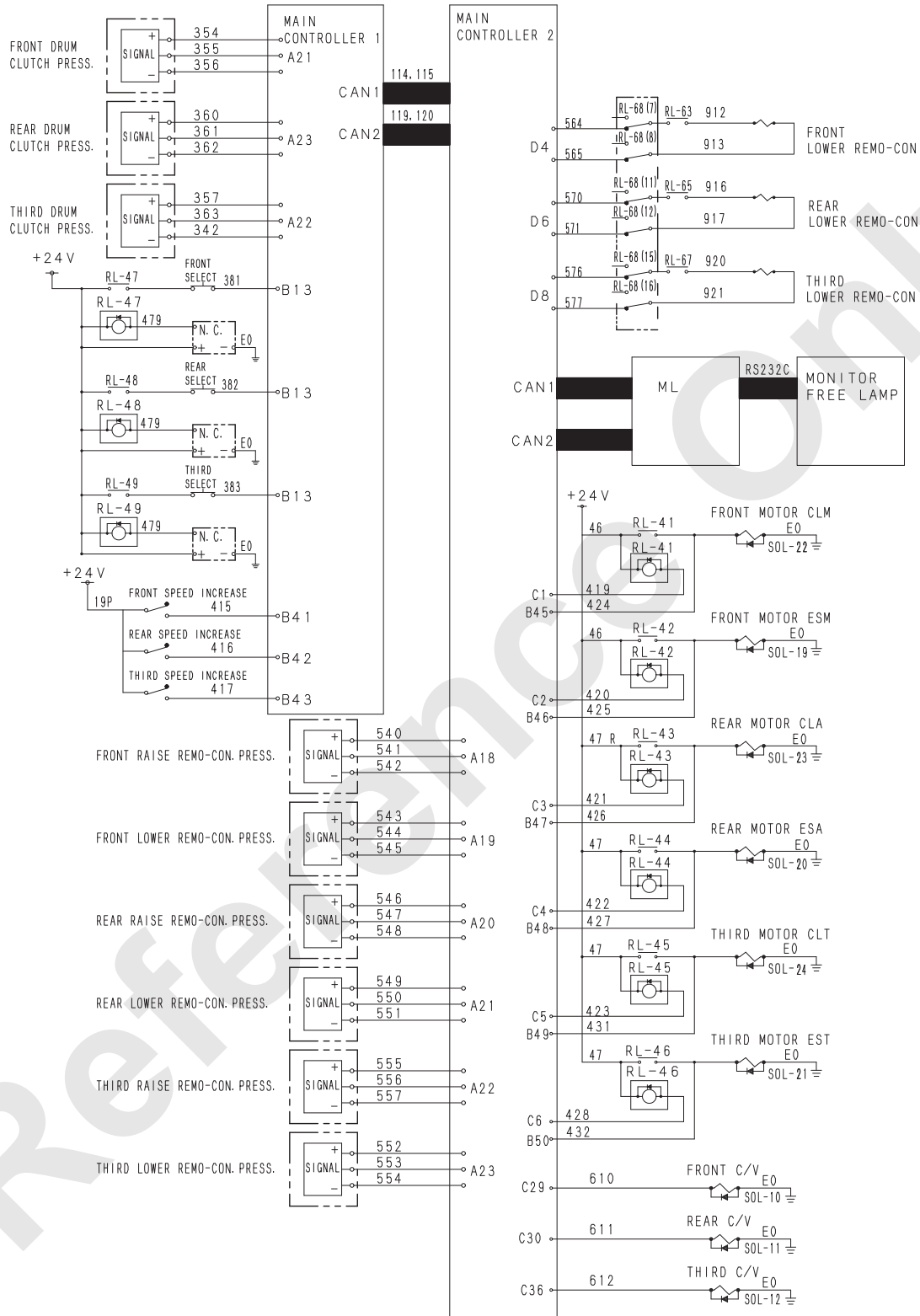

- (A) When power is supplied
The machine always starts running in the neutral brake mode.
- (B) Switching from the brake mode to the free fall mode.

Condition		Output
A. The free fall lock switch is set released. And function lock lever is neutral position.	} → Free release "ON"	<ul style="list-style-type: none"> • Select the free mode. • Light up the free fall indicator lamp. (Monitor indication) • Release the main
B. The foot brake is depressed (the pressure switch is set to the "ON" position). C. The free selector switch is set to the "ON" position.		

- (C) Change from free fall mode to brake mode Depress the foot brake again, and set the free fall mode selector switch to the ON position.
Or, when the free fall permission signal is in the "OFF" status.
- (D) Control of solenoid valve in free fall/brake mode
The front drum CLM (SOL-22) is controlled as shown in the table below.

Lever control	Mode	
	Neutral free	Neutral brake
Hoisting	X	X
Lowering	X	X
Neutral	O	X

O : Energized X : De-energized

- The ON/OFF status of the lever operation is judged by the value from the pressure sensor. (Lever operation is judged to be ON if the pressure is 0.343 MPa or more. It is judged to be OFF if the pressure is not more than 0.196 MPa or less.)
The rear drum CLA (SOL-23) and the third drum CLT (SOL-24) are controlled in a similar manner. When the lever is at the neutral position while the free fall mode is selected, output from the front drum (rear drum and third drum) down remote control proportional valve should depend on the clutch pressure.

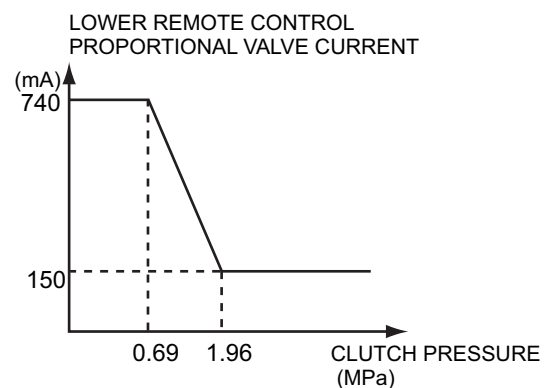

10. ELECTRIC SYSTEM

(E) Emergency solenoid valve control

For the front drum, when either of the conditions below is satisfied, ESM (SOL-19) is energized to prevent a drop of a lifted load.

- 1) The clutch pressure is reduced although the brake mode is selected.
- 2) The clutch pressure is reduced although the lever is operated during the free fall mode.
For the rear drum and the third drum, the ESA (SOL-20) and EST (SOL-21) are controlled, respectively.

Note

Once the emergency solenoid valve is actuated, the current operation mode cannot be altered to the free fall mode unless power to the controller is shut down. Even after the main power supply is shut down while the emergency solenoid valve is being actuated, power supply to the controller remains alive for ninety seconds after the engine is stopped. In this period, the residual clutch pressure is removed.

(3) Free fall acceleration

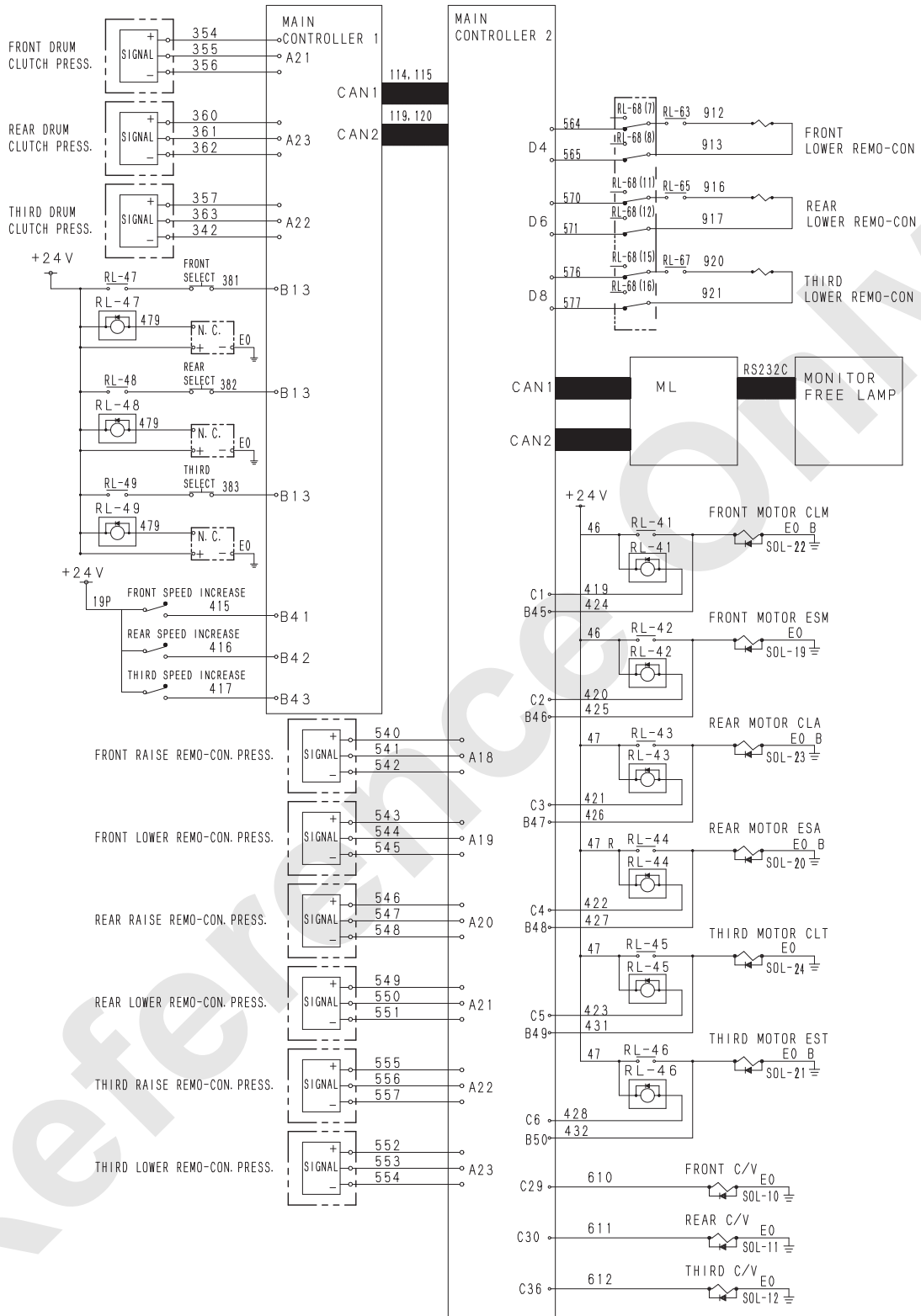

10. ELECTRIC SYSTEM

The falling speed can be increased by idling the motor during the free fall.

The speed is controlled as shown in the table below.

Conditions	Procedures
<ol style="list-style-type: none"> 1. Free fall mode is selected. 2. The control lever is at the neutral position. 3. The "FREE FALL SPEED INCREASE SWITCH" on the left upper of operation seat is ON. 4. The foot brake is not depressed. (Clutch pressure \leq 1.96 MPa., when free fall mode)	<ul style="list-style-type: none"> • C/V solenoid is energized. • Current at the drum control proportional valve is maintained at 463 mA. (The motor keeps running at a high speed.)
Any of conditions shown above is not satisfied.	<ul style="list-style-type: none"> • L/V Solenoid is de-energized. • Other conditions are restored to those of the normal control.

The monitor control proportional valve is controlled according to the depression of the foot pedal (clutch pressure).

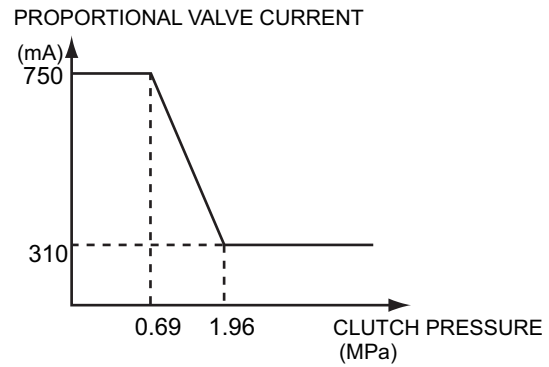

9. BOOST CONTROL

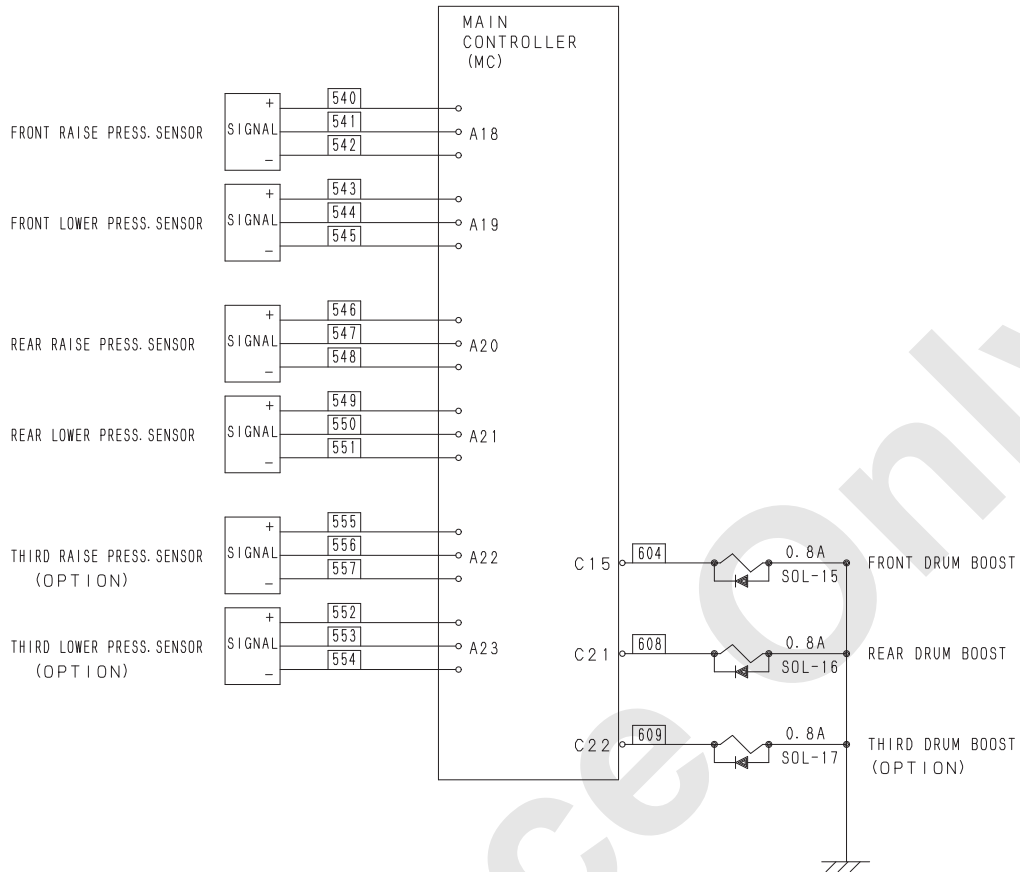

To prevent a momentary drop of a lifted load, apply a constant boost to the motor while the lever is in the neutral position.

The boost solenoid valve is controlled as shown in the table below.

Lever	Boost solenoid valve
Neutral	Energized.
Neutral → raise, lower	Immediately de-energized.
Raise, lower → Neutral	Energized a second after the lever is returned to the neutral position. Remained de-energized if the lever is operated within a second after the lever is returned to the neutral position.

When the front drum or rear drum is stopped, the boost solenoid valve is controlled as shown in the table below.

Stop signal	Boost solenoid valve
Front drum raise stop	Front drum boost solenoid is immediately de-energized.
Rear drum raise stop	Rear drum boost solenoid is immediately de-energized.
Third drum raise stop	Third drum boost solenoid is immediately de-energized.

10. ELECTRIC SYSTEM

10. BOOM STOP CONTROL

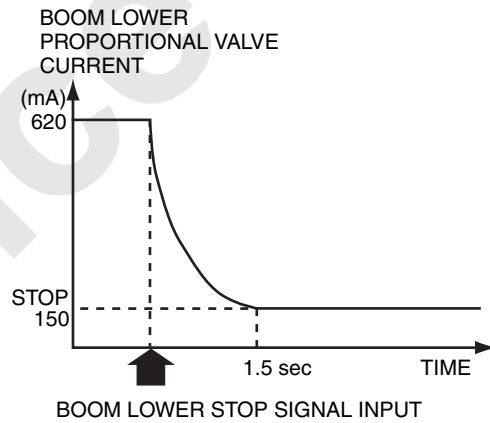
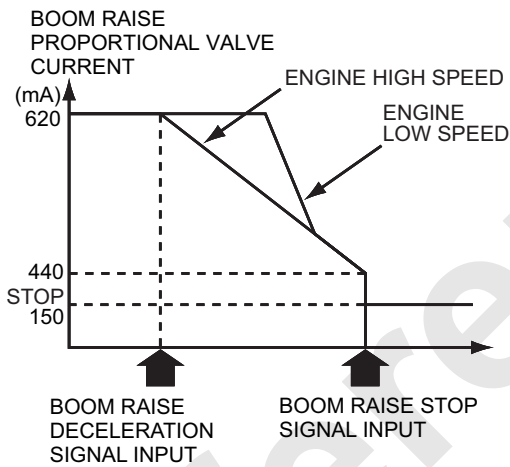
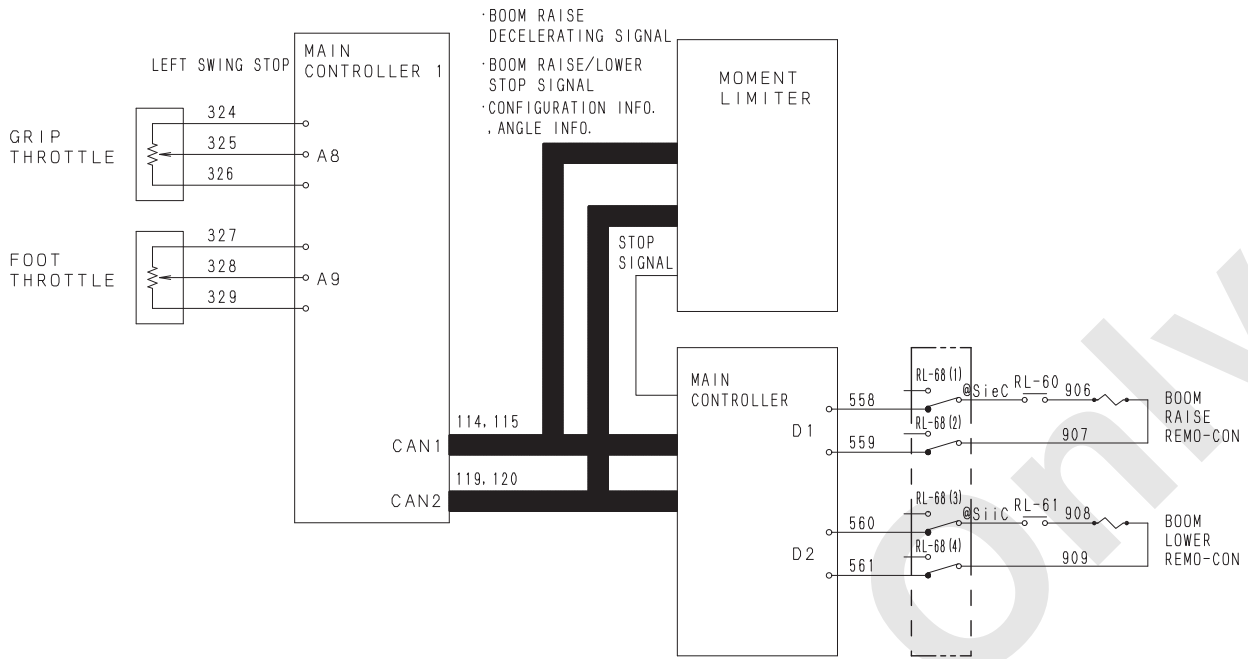

When boom raise deceleration signals are input (input when the boom reaches the angle smaller than the boom upper limit angle by 10 degrees), the boom raise remote control proportional valve is controlled and the boom raising speed is decelerated according to the boom angle.

When the boom lower stop signals are input, the current value at the boom lower proportional valve is minimized within 1.5 seconds, and the boom is slowly stopped.

13. FRONT DRUM HOISTING STOP / REAR DRUM HOISTING STOP

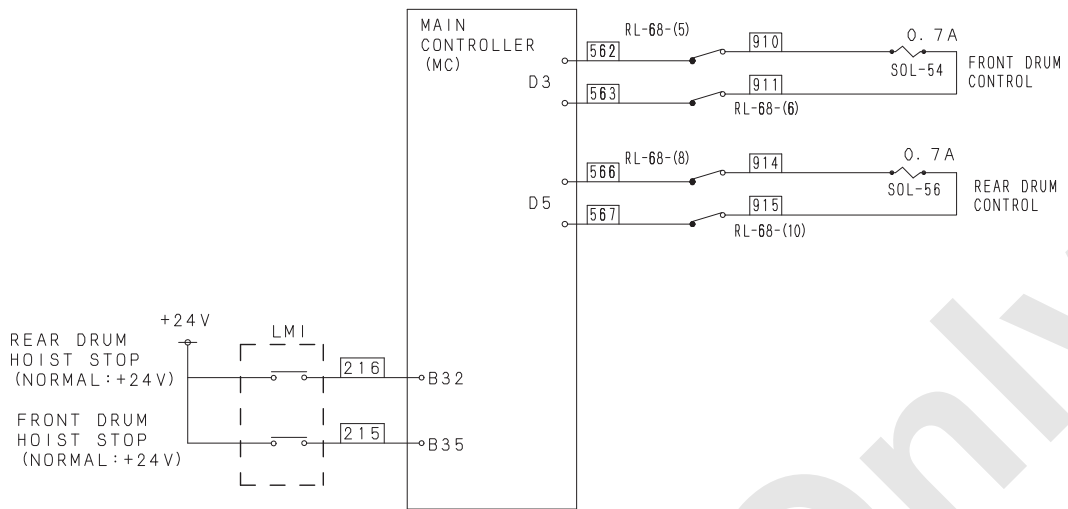

FRONT DRUM HOIST PROPORTIONAL VALVE CURRENT

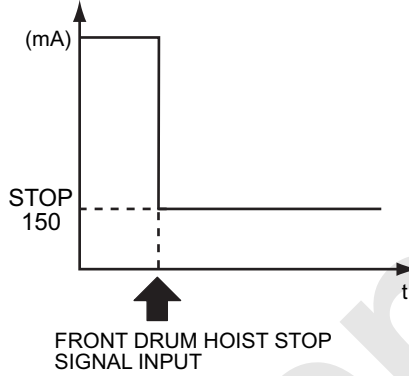

REAR DRUM HOIST PROPORTIONAL VALVE CURRENT

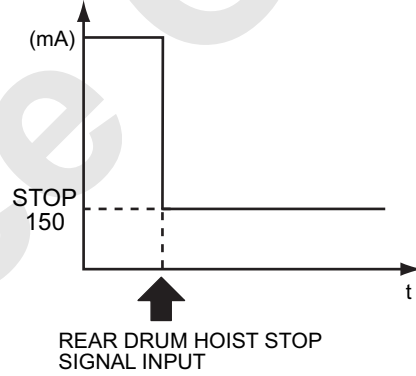

10. ELECTRIC SYSTEM

14. MOTOR TILT ANGLE CONTROL

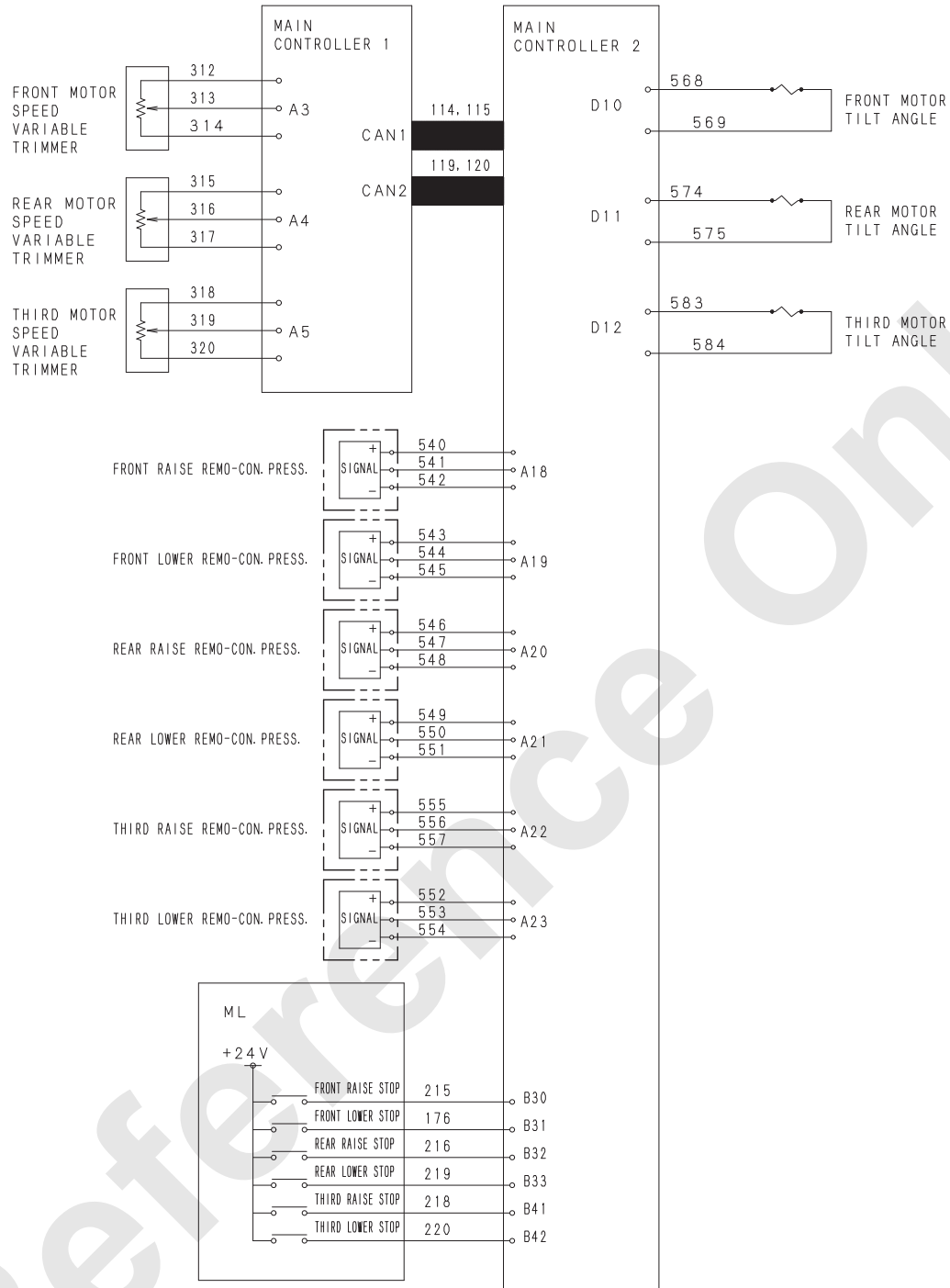

(1) During raising or lowering at brake mode or free mode, current of each motor tilt angle prop. valve is controlled as follows.

(Trimmer control)

(A) Current of motor tilt angle prop. valve varies based on lever motion and speed variable trimmer position.

1) Front drum and rear drum

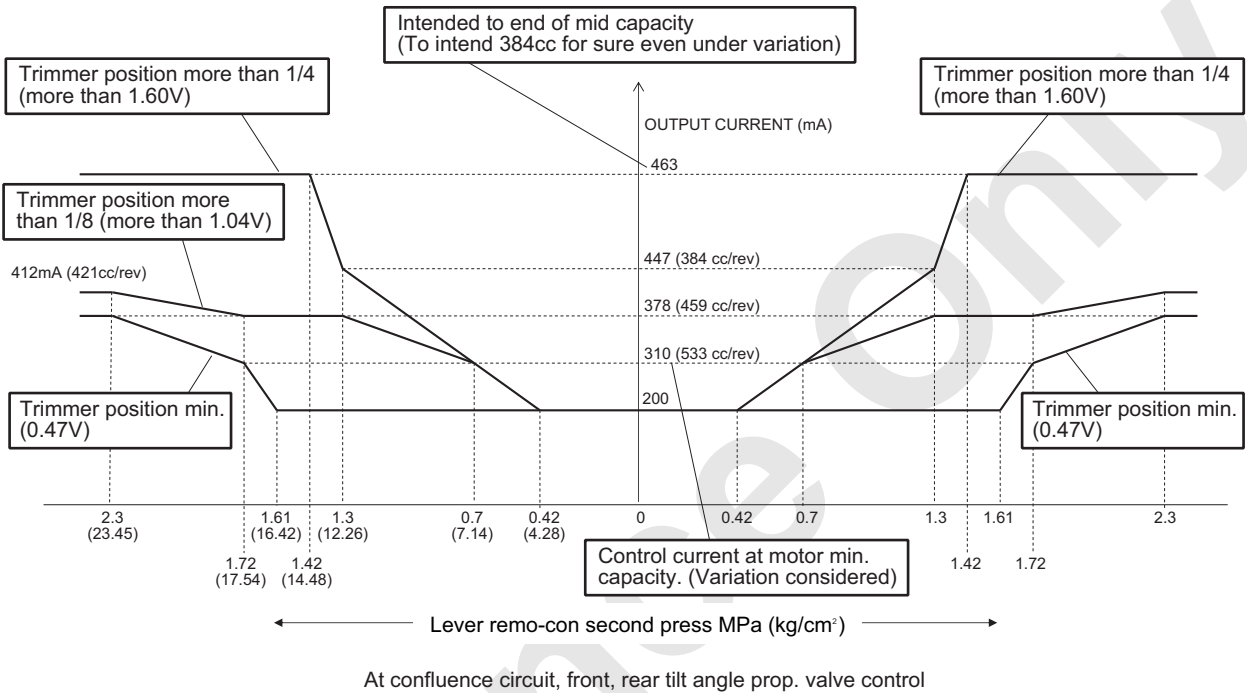

2) Third drum

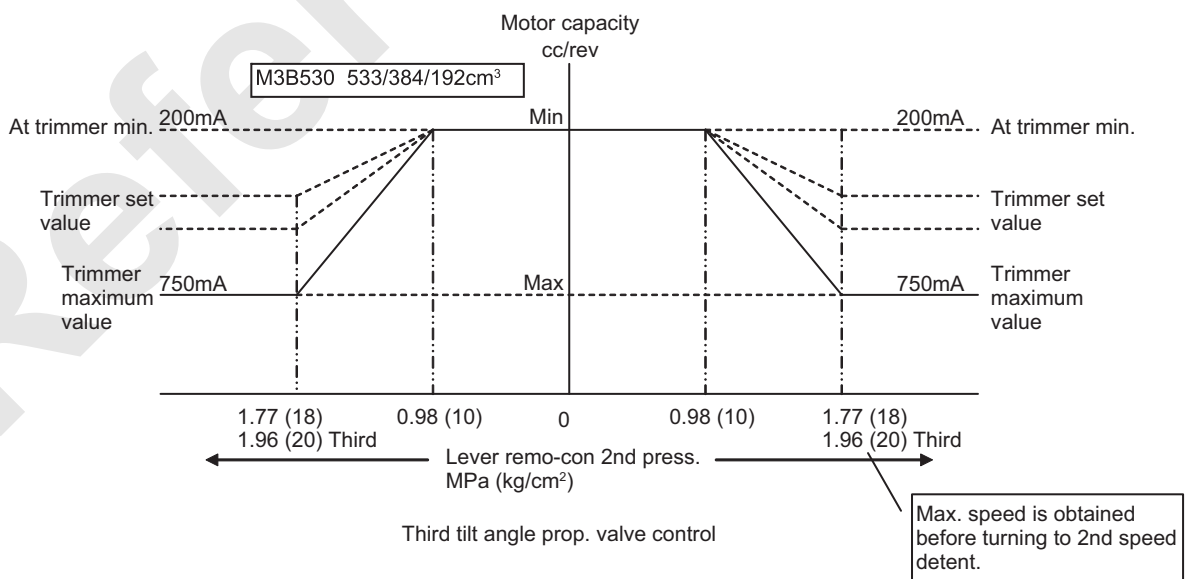

10. ELECTRIC SYSTEM

- (B) Maximum current of motor tilt angle prop. valve is controlled by no load engine speed (Command volume by grip).

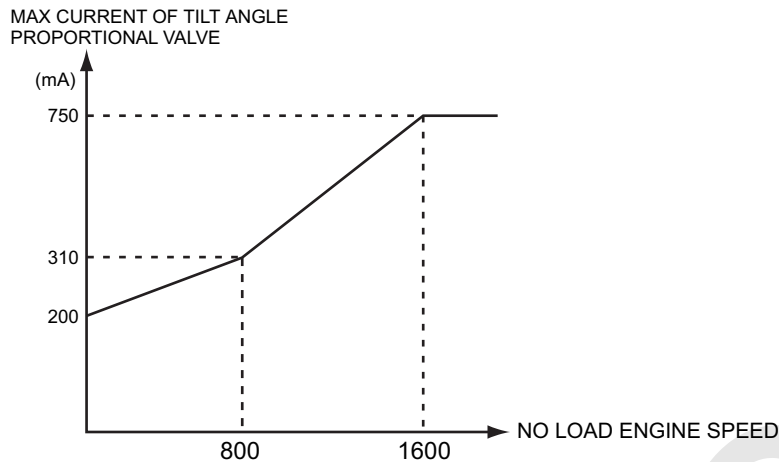

- (2) When auto-stopped
In case of drum auto-stop, output is to be 200 mA.
But if operated toward safe side (not auto-stop side), it shall return to the value by other control.
- (3) Luffing mode speed control
In case luffing mode is selected by ML (by ML transmission) third motor high speed is cut off by output control of rear motor tilt angle prop. valve.
Prop valve current is cut off to make rear tilt angle pressure lower than 2.11 MPa (3.37 V)
- (4) Clamshell mode
In case work mode select is ON (= low speed is selected (Heavy load clam), front motor tilt angle and rear motor tilt angle are fixed to low. (prop valve current is fixed to 200 mA)
(In case of tower specification, this is not done.)
- (5) Priority order is as follows.
Auto stop (this section) > free speed increase > main pump inching speed > clamshell mode (this section) > trimmer control (this section) > tower mode speed control (this section)

Between trimmer lever control value or engine speed control value, smaller value is selected as maximum value.

15. HOOK OVER HOIST CONTROL

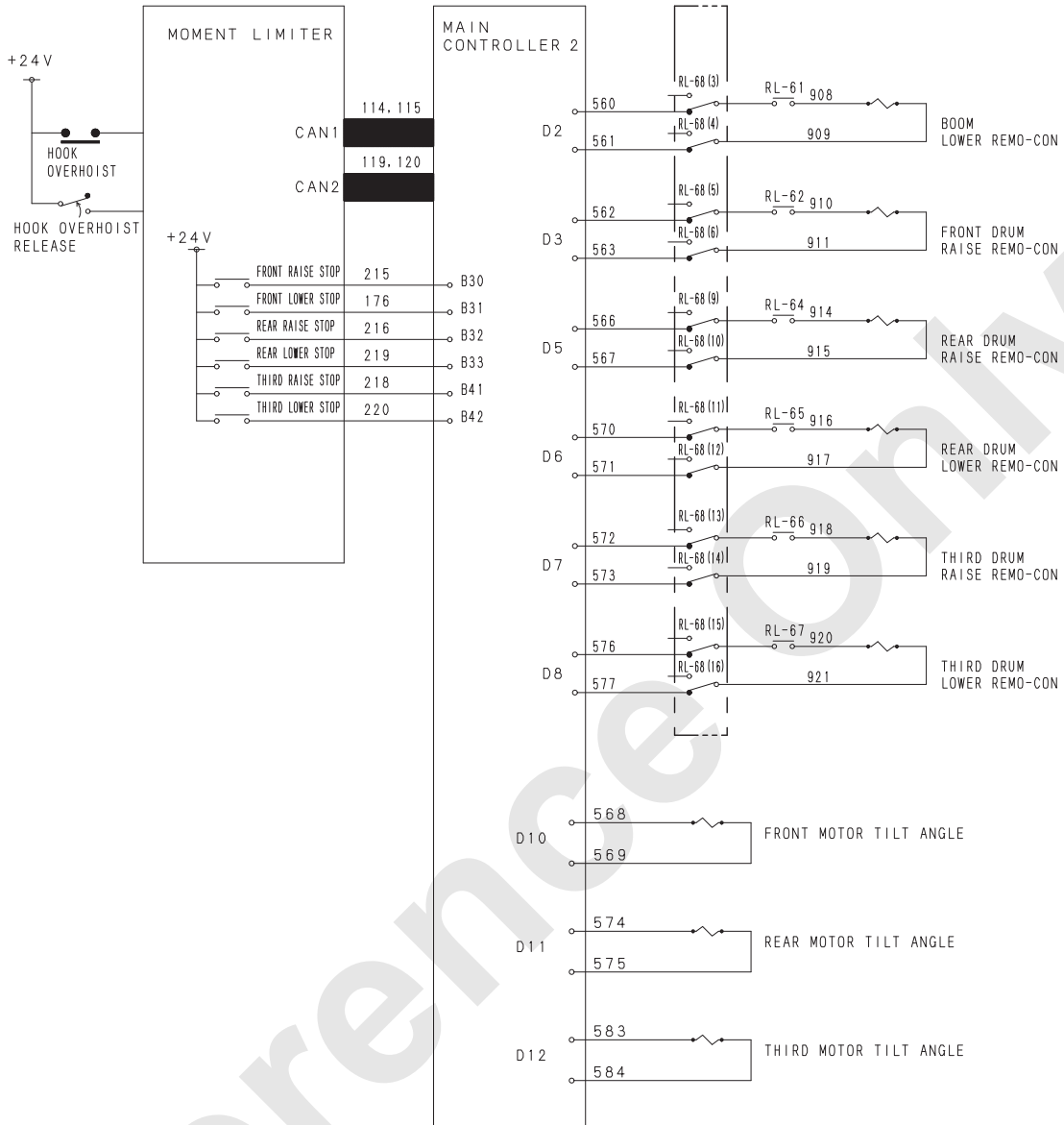

(1) Action at hook over hoist

Output of corresponding remo-con. valves shall be 150 mA when hook over hoist notice is received with CAN transmission from ML.

At the same time, stop signal from ML is input and stop action is done.

[Stop corresponding re-con. prop. valve]

Front raise remo-con prop. valve

Rear raise remo-con prop valve → But in case of tower configuration, stop action is not executed.

Rear lower remo-con prop. valve → But in case of tower configuration only, stop action is executed.

Boom hoist lower remo-con prop. valve

Third raise remo-con prop. valve → But in case of luffing configuration.

Third lower remo-con. prop. valve → But in case of luffing configuration only, stop action is executed.

10. ELECTRIC SYSTEM

(2) Action at hook over hoist

When hook over hoist is released at hook over hoist occurs, the following action is done.

Front, rear and third (jib) raise remo-con. prop. valve command current are set to inching speed level. (375 mA)

If each lever is in operation, each tilt angle prop. valve output is fixed to Low. (310 mA)

Reference Only

16. DRUM ROTATION DETECT GRIP CONTROL

(OPTION)

This can control the grip solenoid based on drum rotation sensor input.

Grip solenoid output becomes OFF when the drum speed exceeds the specified level.

Specified speed. = drum speed :

about 61.5 min^{-1} = more than 4 pulse at 50 m sec.

Therefore there is no output from the total controller.

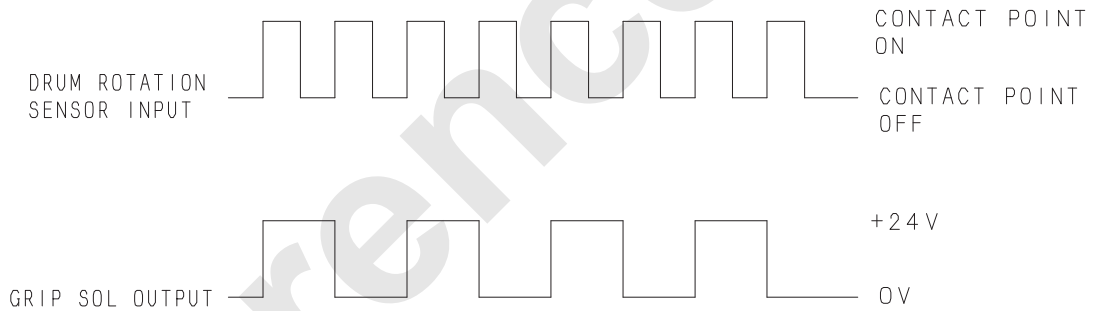
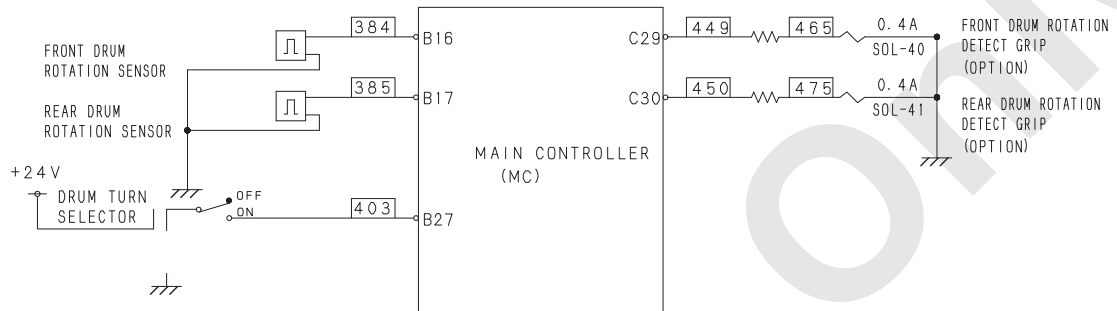

10. ELECTRIC SYSTEM

17. FRONT/BOOM PUMP CONTROL

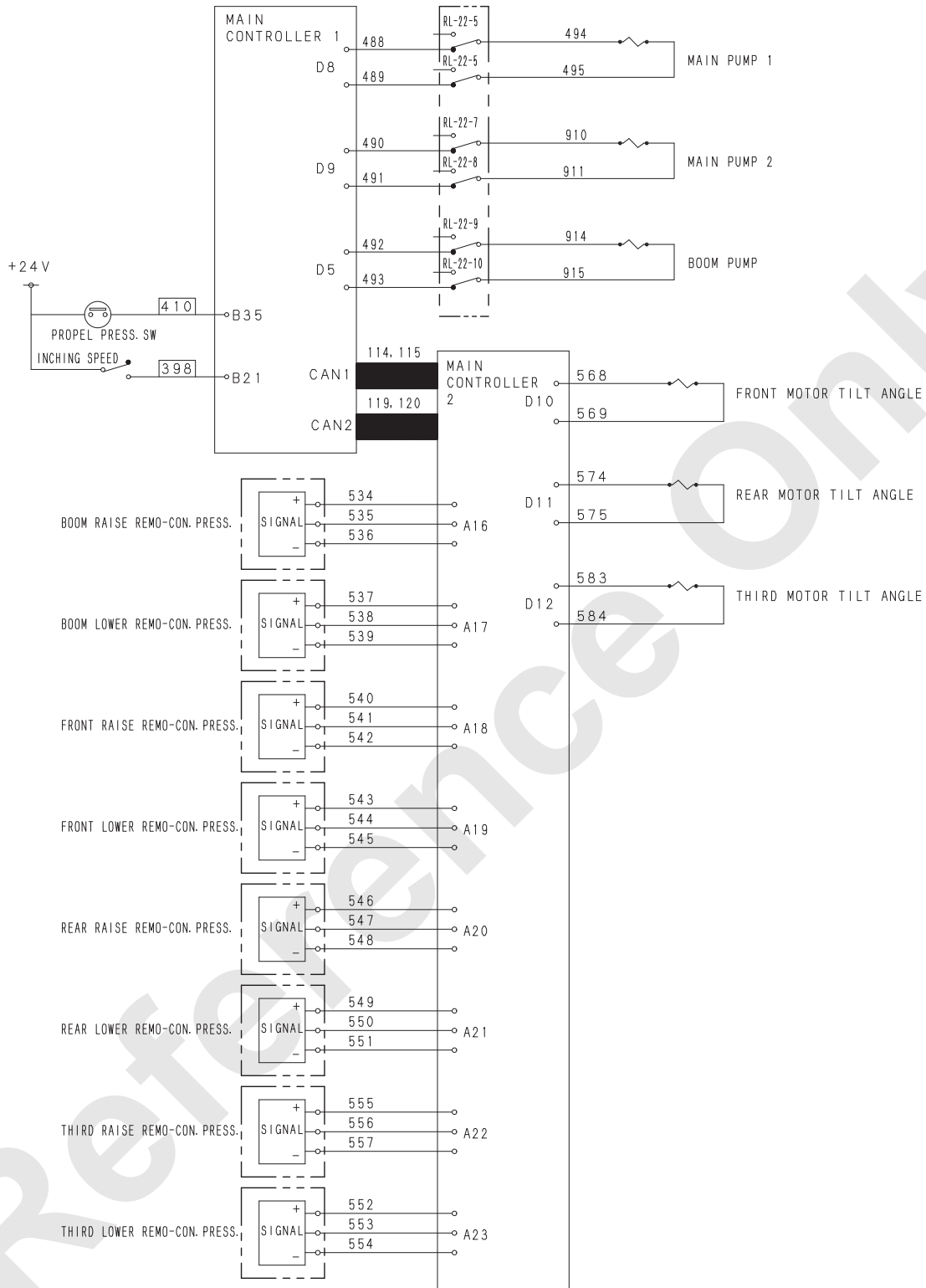

(1) Feathering control :

This is to control the tilt angle proportional (prop.) valve of each pump based on lever motion.

Pump	Prop. valve	Lever motion				
		Front	Rear	Boom	Propel L	Propel R
Main F Main R	Main pump tilt angle 1	Release	Release	Release	Release	Release

- The corresponding prop. valve is released based on lever motion as shown above.
Release : 150 mA
Lever in neutral : 700 mA
- For model with main pump 1, 2, prop valve 1 and 2 are released based on front and rear control motion only at independence mode.
At confluence mode, they are released at the same time.
- Prop. valve released at third drum is lever controlled.
Main pump tilt angle prop. valve is released.

(2) Control at inching switch is IN.

When the inching switch is ON, output becomes 700 mA regardless of lever control.

At this time, motor tilt angle prop. valve is fixed to low. (310 mA)

(3) CKE (CEN conforming) control

(Not required for North American much.)

When ML bypass is effective and switch input is ON, same control as inching switch IN control (2) above is applied.

When ML is released and switch input is ON, same control as inching switch IN control (2) above is applied.

Rein

10. ELECTRIC SYSTEM

18. HEIGHT METER

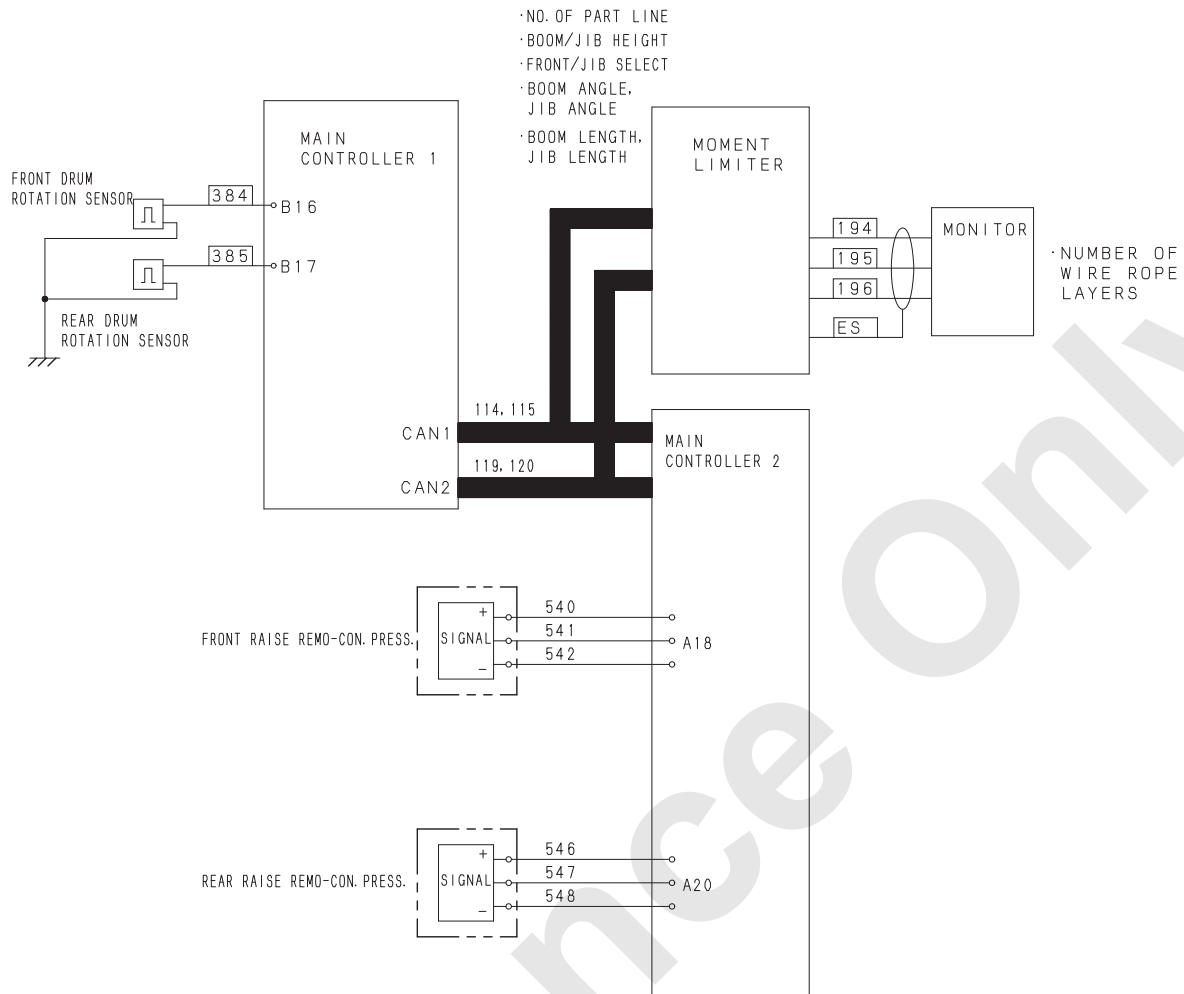

- (1) Drum rotation amount is detected by pulse counting with drum rotation sensor.
- (2) When raise pressure sensor input exists, variation is counted on raising side, and on the other case, variation is counted as + or - on lowering side.
- (3) Layer no. adjusted as the reference point in the main monitor, no. of layer is calculated during rotation.
- (4) From the factor of each layer and pulse number, rope payout amount is calculated.
- (5) Winch height is calculated by dividing with no. of part line.
- (6) With moment limiter, boom point height data is received (jib point height in case of tower). Difference between height of zero reset time and the present height is calculated and the boom or jib height is calculated.
- (7) Distance variation of hook and boom point (jib point) is calculated by angle variation of boom (jib).

(8) Actual height variation is calculated by adding (5) to (7) and is indicated on main monitor.

- To make this control effective, option setting is required.

Reference Only

10. ELECTRIC SYSTEM

19. LEVER INTERLOCK CONTROL

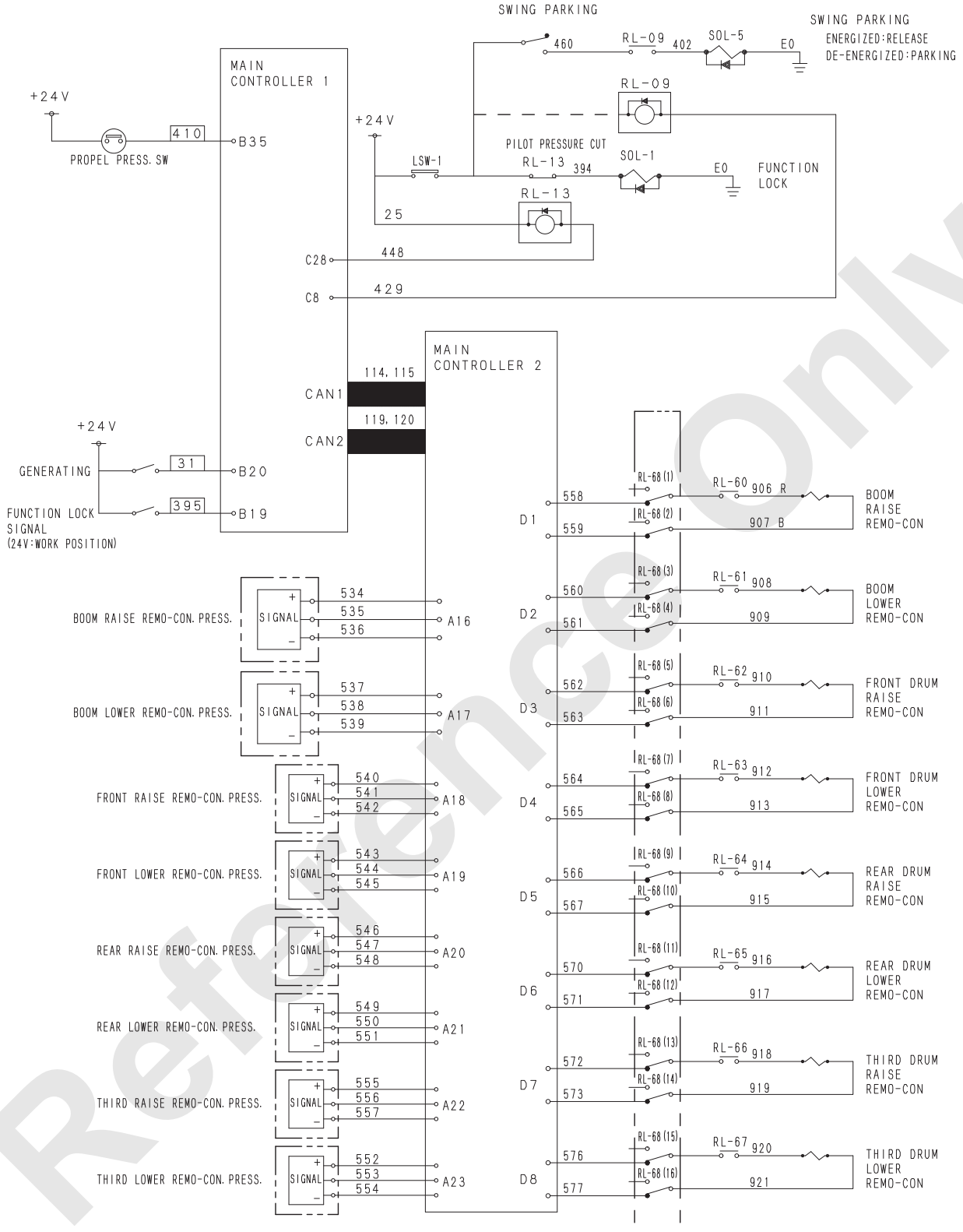

This is to prevent drum unexpected rotation with engine start when the lever is in operating position and the function lock lever is in work position.

(1) Before engine start

Each prop. valve current is minimum. (150 mA)

Pilot cut relay RL-13 is to be output. (pilot cut condition)

Swing parking relay RL-09 is to be output. (Swing parking condition)

(2) After engine started

After generation signal is input, the following actions take place.

(A) In case the function lock lever signal is OFF

1) When propel interlock option is equipped :

Pilot cut relay output becomes ON.

When propel interlock option is not equipped :

Pilot cut relay output is not issued.

2) Swing parking relay output becomes ON.

3) Output of each proportional valve is minimum.

(B) In case the function lock lever signal is work position (+24 V)

1) Output of pilot cut relay becomes OFF. →

If propel control is detected 1 second after pilot cut relay OFF, pilot cut relay becomes ON again. (only when propel interlock option is equipped.)

2) Swing parking relay output becomes OFF.

3) If 3 seconds is elapsed after pilot cut relay OFF, each remo-com prop. valve judges pressure.

If all raise and lower motion levers are in neutral, raise and lower in other control become minimum output. →

Either one of control is detected as MOTION, all prop. valve output stay minimum as is.

Control stop condition by lever interlock function is advised to the monitor.

10. ELECTRIC SYSTEM

20. DPF REGENERATION CONTROL

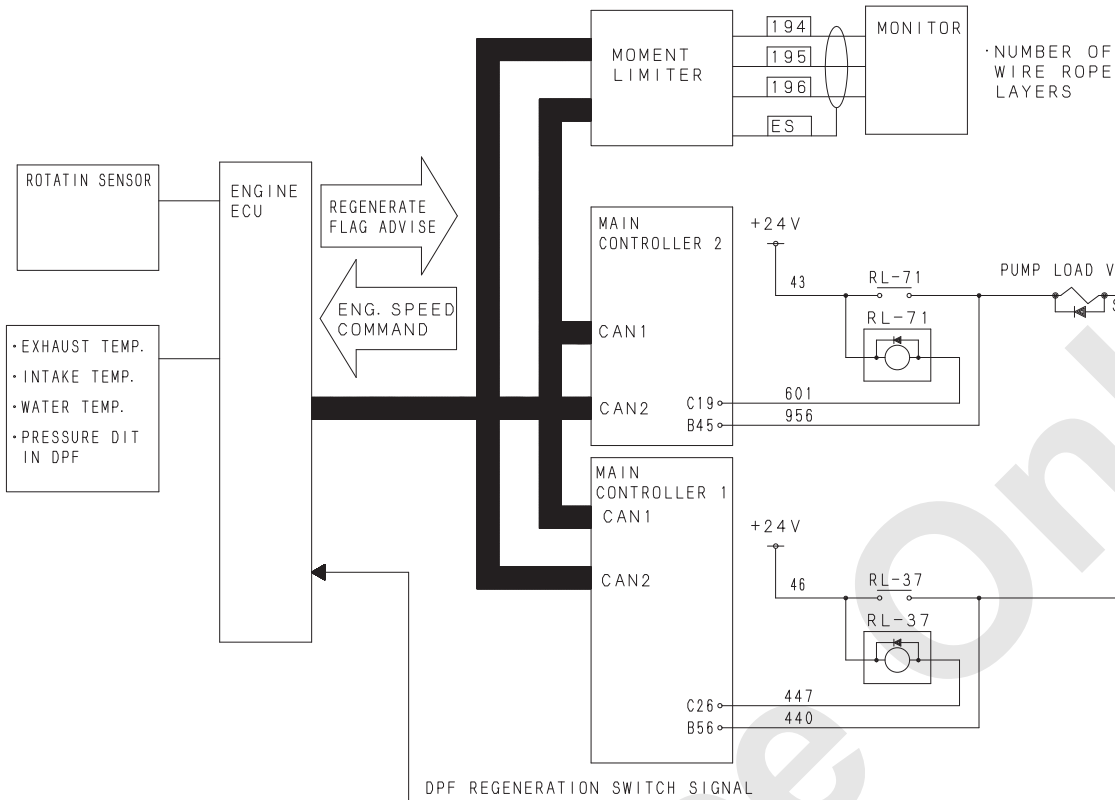

Regeneration starts when more than certain amount of soot is accumulated in DPF (Diesel Particulate Filter).

Counting of soot accumulated volume and regeneration start timing etc are all done by engine ECU.

However load valve control and engine speed control to raise exhaust temperature in order to prevent regeneration starting during crane control are done by crane side controller.

(1) Auto regeneration

Between 0 and 4 soot gauge bar, the following requests are issued from engine ECU.

Long time idling :

If low idling, low load work is continued, request is issued from ECU.

Idling speed is raised ($1,000 \text{ min}^{-1}$) and load valve becomes ON.

Load valve request :

To raise exhaust temperature, idling speed is raised (900 min^{-1}) and load valve becomes ON.

During auto regeneration :

This is the condition that exhaust temperature is reached to regeneration possible level and engine ECU started regeneration.

The load valve remains ON but idling speed returns back.

Long time idling can not be canceled.

Others can cancel by only 1.

Reference

10. ELECTRIC SYSTEM

(2) Manual regeneration

Between 5 and 9 soot gauge bar, the following requests are issued from engine ECU.

Manual regeneration request :

After engine ECU request, regeneration switch and cancel switch become indicated on the main monitor.

Manual regeneration preparation :

When regeneration switch is pushed, regeneration start signal from the main controller 1 to ECU is issued.

At this time, crane control becomes impossible and engine speed is raised to 1,000 min⁻¹.

Engine ECU issues preparation flag output after regeneration start signal is input.

During Manual regeneration :

This is the condition that exhaust temperature is reached to regeneration possible level and engine ECU started regeneration.

Crane condition is as same as "Manual regeneration preparation".

Manual regeneration is possible at soot gauge up to 7 bar.

When soot gauge becomes 9 bar, forcible regeneration starts by detecting no control condition.

The content of action is as same as manual regeneration and action starts without requesting permit to crane operator.

The above request flag content of ECU can be checked in the main controller 1 output, input condition of service diagnosis screen.

Soot bar indication	ECU advice content	MC condition	
10	Regeneration impossible error code output	Error indication	DPF replacement becomes necessary.
9	Manual regeneration request	Load valve forcibly ON, speed fixed to 1,000 min ⁻¹	Forcible regeneration occurs to prevent DPF replacement.
8	Manual regeneration preparation	Regeneration switch indication	Regeneration is done with operators permit. → Crane operation is not possible.
7		Load valve ON	
6	During Manual regeneration	Speed 1,000 min ⁻¹	
5		Control impossible	
4	Long time idling Load valve request During auto regeneration	Load valve ON Speed 800 to 1,000 min ⁻¹ Control possible	Auto regeneration is done. → Crane operation is possible.
3			
2			
1			
0			

10. ELECTRIC SYSTEM

22. G WINCH CONTROL

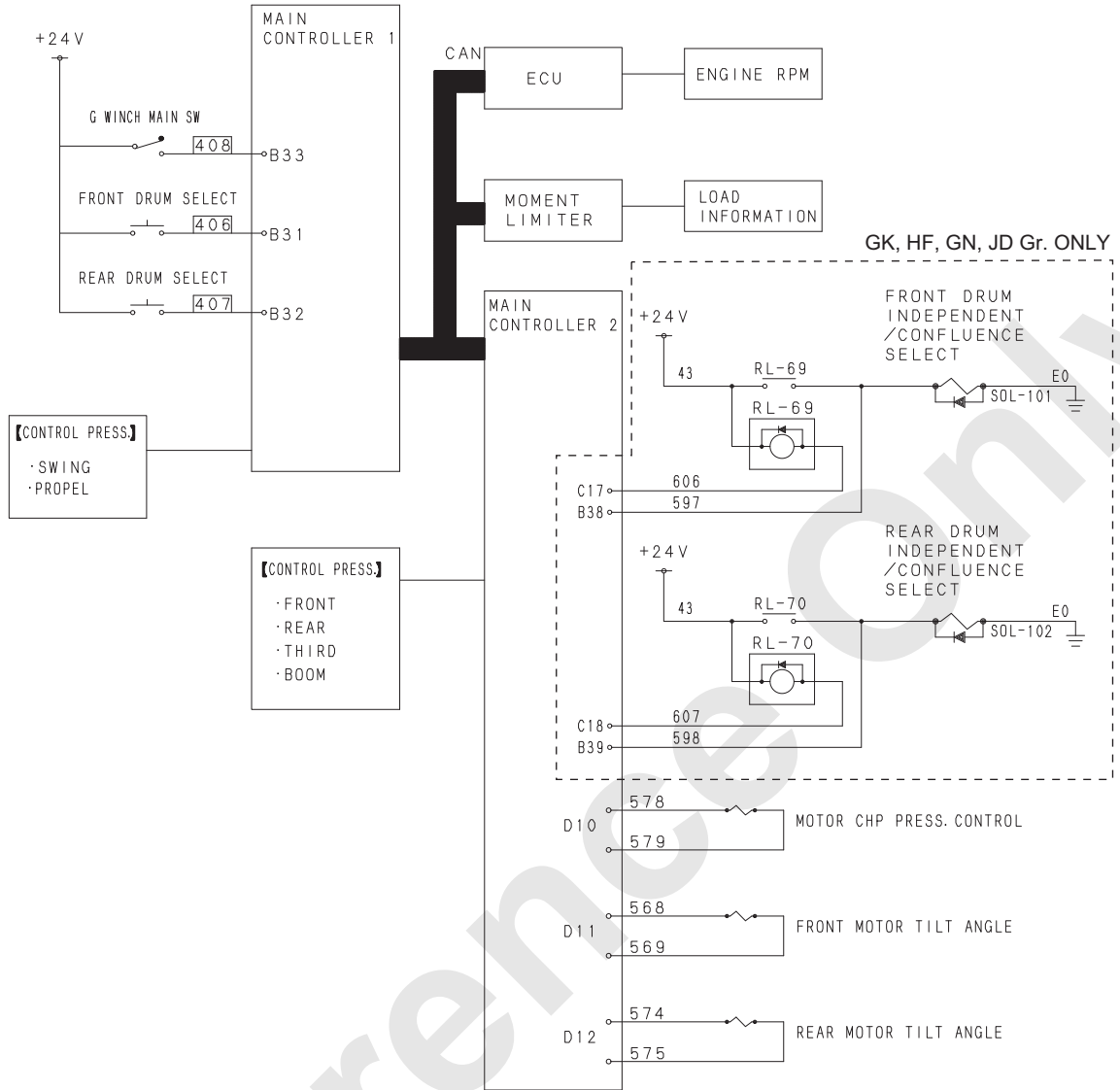

(1) G winch mode selecting

This is to make individual select switch, which is set individually for front/rear based on input of G winch select switch effective.

When individual switch is input, G winch condition is selected based on the conditions shown in the table.

Mode	Input condition				
	G winch			Lever condition	Engine speed
	Main	(Fr)	(Re)		
Normal mode	OFF	-	-	Neutral	-
G winch main mode	ON	-	-	Neutral	Idle -5% to +5%
G winch (Fr) (Re) mode	ON	ON	ON	Neutral	1,000 min ⁻¹ or lower
		(Ind.)	(Ind.)		

Engine speed upper limit value is a value with G engine function OFF.
 At G engine function ON, upper limit 900 min⁻¹.

(2) G winch individual mode

When individual mode is selected either front or rear drum, the following action occur.

(A) Hydraulic circuit is changed internally to confluence mode. →

In case of independence mode is selected, monitor indication only becomes independence condition.
 Mid detent is also ineffective.

(B) Engine speed is raised to upper limit value.

If G engine OFF, it becomes 1,000 min⁻¹.
 At G engine, it becomes upper limit 900 min⁻¹.

(C) Motor tilt angle control is changed to that of individual mode.

(D) Motor chp prop. valve is changed to the one same as individual mode.

At tower configuration, rear individual mode becomes ineffective.

After either front or rear becomes independence, G winch shall be released by one lever control (neutral → operation → neutral)

In case G winch function is required again, the individual switch is input.

After switched to individual mode and individual switch is pushed again, function is cancelled.

10. ELECTRIC SYSTEM

23. G ENGINE CONTROL

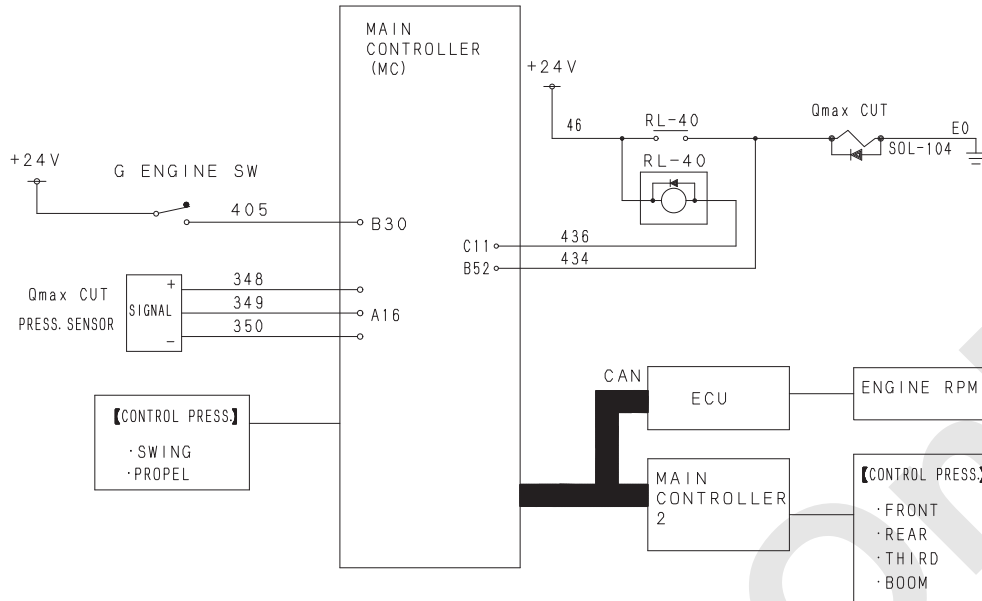

(1) G engine function select switch

After inputting into select switch, check is made on each lever control.

If neutral Q max cut solenoid is energized.

	Input		Output	
	G engine function select	Lever condition	Q max cut SOL	Engine speed control
At G engine	ON	At Neutral	ON	1,725 min ⁻¹
At Normal	OFF	At Neutral	OFF	2,100 min ⁻¹

* At G engine mode, engine speed upper limit is changed as shown in the table.

* Q max cut solenoid becomes de-energized and Q max cut condition is created.
(When energized, pump flow max. value is raised.)

(2) Fail safe

To prevent pump failure, engine speed and Q max cut pressure are always monitored and the following actions are taken at abnormal.

	Abnormal judged value			Action at abnormal	
	Q max cut pressure	Q max cut SOL FB value	Engine speed control	Q max cut SOL	Engine speed control
At G engine	3 MPa or more	OFF	1,800 min ⁻¹ or more	OFF output * at speed abnormal	1,725 min ⁻¹
At Normal	Less than 3 MPa	ON	No judgement		

24. AIS CONTROL

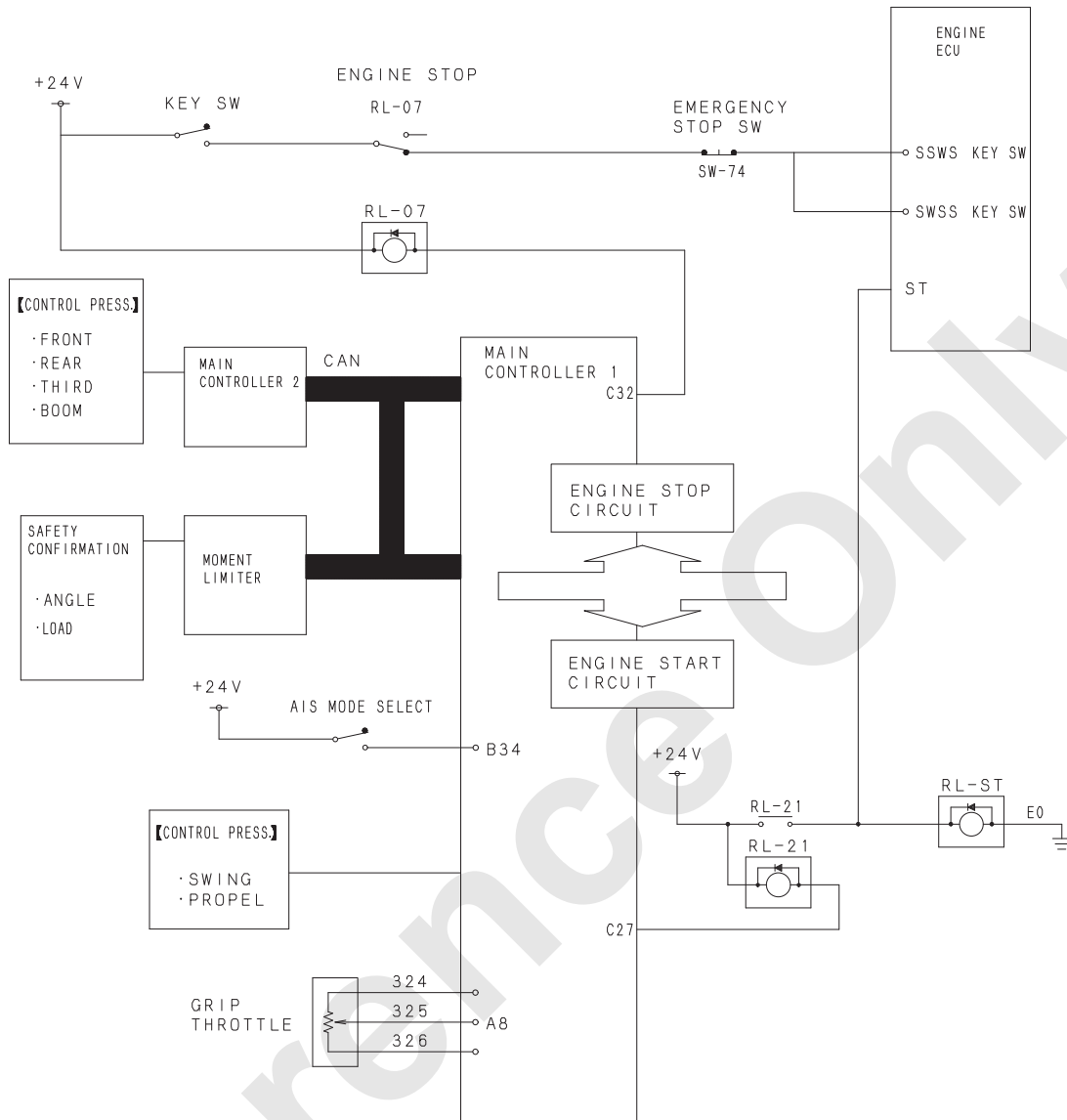

10. ELECTRIC SYSTEM

The above circuit diagram is extract from the main diagram for only related portion of this control.
 (engine stop/re-start)
 When the condition bellows are met, engine stops automatically.

Engine stop condition	Meeting condition	ML permit condition
ML permit	ML permit condition	Configuration condition : Other than assembly/ disassembly, stowing mode Moment limiter released condition : Release key off
No load engine speed	Low idling -5% to +5%	
Free fall	Neutral brake mode	
Parking switch	Parking condition	
Control lever neutral	All neutral incl. swing	
Water temp. condition	40 to 80 °C (104 to 176 °F)	
Oil temp condition	Lower than 60 °C (140 °F)	

(1) Engine stop action

If the conditions are met and operator's cancel does not exist, main controller 1 energize engine stop relay. (RL-07) →
 Key switch signal to engine ECU becomes OPEN condition and engine ECU activate as Key OFF condition.

(2) Engine restart

At AIS condition, control id only applied at engine stop condition. Grip accellerator voltage is monitored and when higher than 20% voltage is detected, engine restart relay (RL-21) becomes energized.
 However if engine does not start within 3 seconds, engine restart relay becomes de-energized regardless of grip voltage.

(3) Key cut off fail preventing function AIS condition may be left for long time.

If AIS condition is continued for longer than certain time, battery is turned OFF automatically.

25. HYD. OIL HEAT (OPTION)

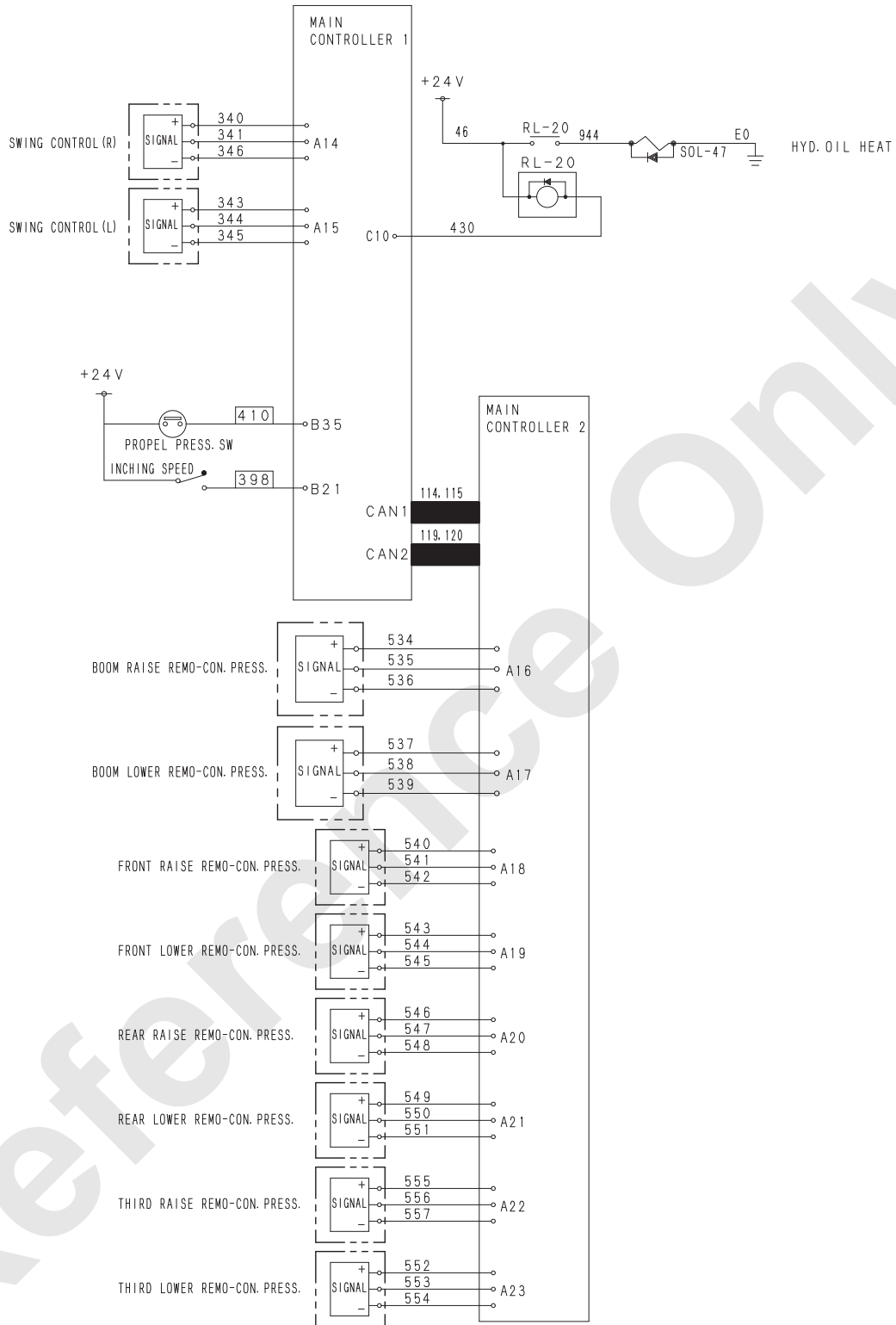

Control	Relay
When all lever is in neutral	Energized
Either on lever is in operation	De-energized

10. ELECTRIC SYSTEM

10.3.4 MAIN CONTROLLER 1, 2 (HARDWARE)

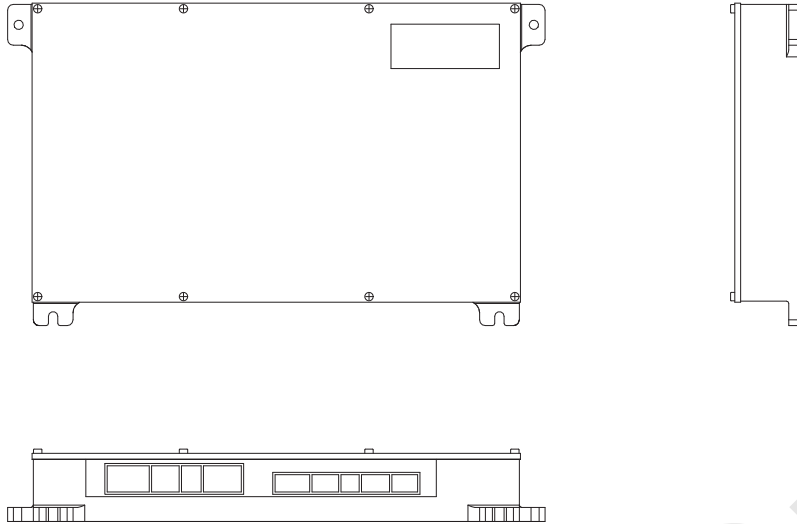

HARNESS SIDE CONNECTOR

MC1 : CN-101F to CN-109F
MC2 : CN-111F to CN-119F

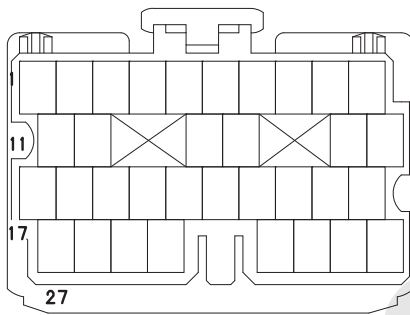

CN-101F
CN-111F

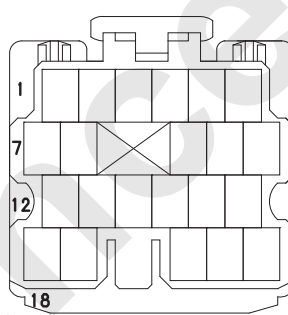

CN-102F
CN-112F

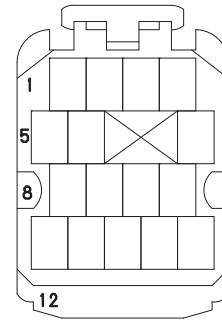

CN-103F
CN-113F

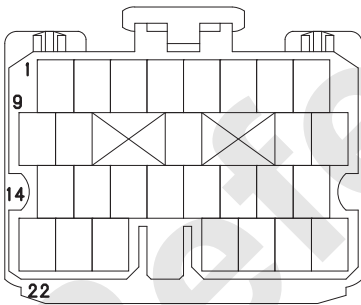

CN-104F
CN-114F

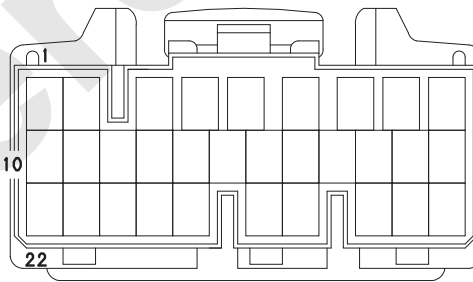

CN-105F
CN-115F

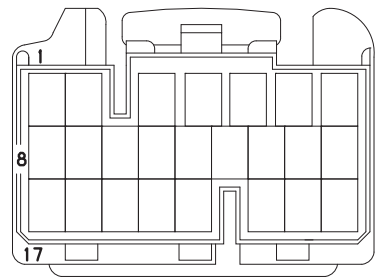

CN-106F
CN-116F

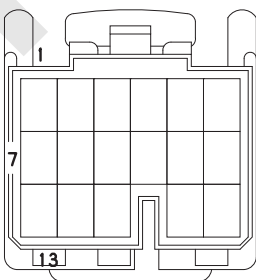

CN-107F
CN-117F

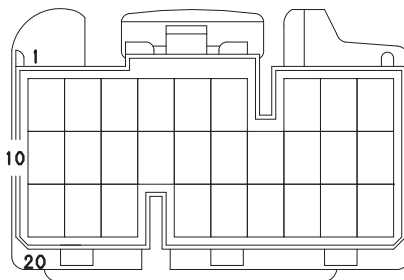

CN-108F
CN-118F

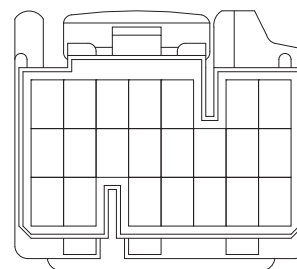

CN-109F
CN-119F

10.3.5 SPECIFICATIONS OF MAIN CONTROLLER OUTPUT**1. SPECIFICATIONS OF MAIN CONTROLLER 1
INPUT/OUTPUT****(1) ANALOGUE INPUT [A]**

No.	Name	Range	Input voltage
1	A/D Spare		
2	A/D Spare		
3	Fr. drum motor speed adjusting trimmer	0 to FULL	0.43 to 5 V
4	Re. drum motor speed adjusting trimmer	0 to FULL	0.43 to 5 V
5	Third drum motor speed adjusting trimmer	0 to FULL	0.43 to 5 V
6	Boom drum motor speed adjusting trimmer	0 to FULL	0.43 to 5 V
7	Spare A/D	0 to FULL	0.43 to 5 V
8	Grip throttle	LOW to HIGH	0.7 to 5 V
9	Foot throttle (option)	LOW to HIGH	1.0 to 4.4 V
10	Hyd. oil temperature sensor	50 to 130°C (122 to 266°F)	117.9 Ω to 9.6 Ω
11	Tagline trimmer (option)	0 to FULL	0.43 to 5 V
12	Control primary pressure	0 to 19.61 MPa	0.5 to 4.5 V
13	Swing pump pressure sensor	0 to 49.03 MPa	0.5 to 4.5 V
14	Swing operation (right) pressures sensor	0 to 2.94 MPa	0.5 to 4.5 V
15	Swing operation (left) pressures sensor	0 to 2.94 MPa	0.5 to 4.5 V
16	Qmax cut solenoid detection pressure	0 to 49.03 MPa	0.5 to 4.5 V
17	Power shift pressures sensor	0 to 2.94 MPa	0.5 to 4.5 V
18	Supply voltage monitor	19 V to 32 V	0.5 V to 4.8 V
19	Inclination detector X	-5 to +5 deg.	0.5 to 4.5 V
20	Inclination detector Y	-5 to +5 deg.	0.5 to 4.5 V
21	Fr. drum clutch pressure sensor	0 to 19.61 MPa	0.5 to 4.5 V
22	Third drum clutch pressure sensor (option)	0 to 19.61 MPa	0.5 to 4.5 V
23	Re. drum clutch pressure sensor	0 to 19.61 MPa	0.5 to 4.5 V

10. ELECTRIC SYSTEM

(2) DIGITAL INPUT [B]

No.	Name	Status	Signal level
1	ECU status signal	Power ON/OFF	Ground (15 kΩ)/OPEN
2	Engine hyd. pressure PSW	Engine Stop/Work	Ground (15 kΩ)/OPEN
3	CB/W detect	Detection/Non-detection	Ground (15 kΩ)/OPEN
4	Clogging of Engine air cleaner	Clogging/Normal	Ground (15 kΩ)/OPEN
5	Vacancy		Ground (3.3 kΩ)/OPEN
6	Fr. drum brake cooling oil temperature	Higher temperature/Normal	Ground (3.3 kΩ)/OPEN
7	Re. drum brake cooling oil temperature	Higher temperature/Normal	Ground (3.3 kΩ)/OPEN
8	Radiator water level	Low level/Normal	Ground (3.3 kΩ)/OPEN
9	Engine oil filter	Clogging/Normal	Ground (3.3 kΩ)/OPEN
10	Fr. drum control signal	ON/OFF	Ground (3.3 kΩ)/OPEN
11	Re. drum control signal	ON/OFF	Ground (3.3 kΩ)/OPEN
12	Third drum control signal	ON/OFF	Ground (3.3 kΩ)/OPEN
13	Fr. drum free fall select. signal	Free/Brake	+24 V/OPEN
14	Re. drum free fall select. signal	Free/Brake	+24 V/OPEN
15	Third drum free fall select. signal	Free/Brake	+24 V/OPEN
16	Fr. drum rotation sensor	0 to 500 min ⁻¹	Ground (3.3 kΩ)/OPEN
17	Re. drum rotation sensor	0 to 500 min ⁻¹	Ground (3.3 kΩ)/OPEN
18	Key switch ON signal	ON/OFF	+24 V/OPEN
19	Function lock	Work/Function	+24 V/OPEN
20	Charge signal	E/G work/Stop	+24 V/OPEN
21	Inching select switch	Inching/Normal	+24 V/OPEN
22	Aux. accel. signal	ON/OFF	+24 V/OPEN
23	Engine emg. stop signal	Stop/Normal	+24 V/OPEN
24	Engine restart	Work/Normal	+24 V/OPEN
25	Operator certify wait signal	Uncertify/Certify	+24 V/OPEN
26	Swing parking switch	Release/Parking	+24 V/OPEN
27	Drum rotation detect grip selection	Select/Non-select	+24 V/OPEN
28	Controller ID 1	B28=ON, B29=OFF ⇒ MC1	+24 V/OPEN
29	Controller ID 2	B28=OFF, B29=ON ⇒ MC2	+24 V/OPEN
30	G mode/Normal selection	G mode/Normal	+24 V/OPEN
31	G winch (Fr.)	High speed/Normal	+24 V/OPEN
32	G winch (Re.)	High speed/Normal	+24 V/OPEN
33	Energy saving winch (main)	ON/OFF	+24 V/OPEN
34	AIS function ON/OFF switch	ON/OFF	+24 V/OPEN
35	Propelling operating pressure switch	Control/Neutral	+24 V/OPEN
36	Vacancy	0 to 500 min ⁻¹	Ground (3.3 kΩ)/OPEN
37	Cooling line filter	Clogging/Normal	Ground (3.3 kΩ)/OPEN
38	Engine preheat	Preheat/Normal	+24 V/OPEN
39	Vacancy		+24 V/OPEN
40	Backup fuse	Normal/Fusion	+24 V/OPEN
41	Fr. drum free fall speed increase switch	High/Normal	+24 V/OPEN
42	Re. drum free fall speed increase switch	High/Normal	+24 V/OPEN
43	Third drum free fall speed increase switch (option)	High/Normal	+24 V/OPEN
44	Free fall permit signal	Permit/Lock	+24 V/OPEN
45	Fr. drum motor CLM-SOL (FB)	Energized/De-energized	+24 V/OPEN
46	Fr. drum motor ESM-SOL (FB)	Energized/De-energized	+24 V/OPEN
47	Re. drum motor CLA-SOL (FB)	Energized/De-energized	+24 V/OPEN
48	Re. drum motor ESA-SOL (FB)	Energized/De-energized	+24 V/OPEN
49	Third drum motor CLT-SOL (FB)	Energized/De-energized	+24 V/OPEN
50	Third drum motor EST-SOL (FB)	Energized/De-energized	+24 V/OPEN

No.	Name	Status	Signal level
51	Hyd. oil heat LS (OPT)	Energized/De-energized	+24 V/OPEN
52	Pump Qmax cut solenoid (FB)	Energized/De-energized	+24 V/OPEN
53	Remote control connection signal	Connected/Unconnected	+24 V/OPEN
54	Swing warning (flasher)	Flasher ON/OFF	+24 V/OPEN
55	Swing warning (buzzer and flasher)	Buzzer and flasher ON/OFF	+24 V/OPEN
56	DPF regeneration (FB)	Energized/De-energized	+24 V/OPEN
57	Accel. signal (DOWN)	Rotate down/Holding	+24 V/OPEN
58	Accel. signal (UP)	Rotate up/Holding	+24 V/OPEN

(3) ANALOGUE OUTPUT [H]

No.	Name	Status	Signal level
1	Accel opening signal 1	800 min ⁻¹ to 2,100 min ⁻¹	1 to 4 V
2	Accel opening signal 2	800 min ⁻¹ to 2,100 min ⁻¹	1 to 4 V

(4) PROPORTIONAL VALVE OUTPUT [D]

No.	Name	Output current	Dither
1	Main pump power reduction prop. valve	100 to 700 mA	200 mAp-p 100 Hz
2	Boom pump power reduction prop. valve	100 to 700 mA	200 mAp-p 100 Hz
3	Swing low speed prop. valve	100 to 700 mA	200 mAp-p 100 Hz
4	Swing counterforce prop. valve	150 to 510 mA	200 mAp-p 160 Hz
5	Boom pump tilt angle control prop. valve	150 mA to 700 mA	200 mAp-p 100 Hz
6	Fr. drum middle detent	60 mA to 110 mA	None
7	Re. drum middle detent	60 mA to 110 mA	None
8	Main pump tilt a. control prop. valve 1	150 mA to 700 mA	200 mAp-p 100 Hz
9	Main pump tilt a. control prop. valve 2	150 mA to 700 mA	200 mAp-p 100 Hz
10	Tagline prop. valve	100 to 700 mA	200 mAp-p 63 Hz
11	Left swing stop prop. valve	100 to 700 mA	200 mAp-p 100 Hz
12	Right swing stop prop. valve	100 to 700 mA	200 mAp-p 100 Hz

10. ELECTRIC SYSTEM

(5) DIGITAL OUTPUT [C]

No.	Name	Status	Signal level
1	Fr. drum motor CLM-SOL	Energized/De-energized	GND/OPEN
2	Fr. drum motor ESM-SOL	Energized/De-energized	GND/OPEN
3	Re. drum motor CLA-SOL	Energized/De-energized	GND/OPEN
4	Re. drum motor ESA-SOL	Energized/De-energized	GND/OPEN
5	Thirddrum motor CLT-SOL	Energized/De-energized	GND/OPEN
6	Thirddrum motor EST-SOL	Energized/De-energized	GND/OPEN
7	Vacancy		GND/OPEN (300 mA)
8	Swing parking control	Parking/Release	GND/OPEN (300 mA)
9	ML adjust. mode selection	Adjust. Mode/Normal	GND/OPEN (300 mA)
10	Hyd. oil heat SOL	Heat/Normal	GND/OPEN
11	Pump Qmax cut solenoid	Energized/De-energized	GND/OPEN
12	Swing flasher	Lit up/Unlit	GND/OPEN
13	Vacancy		GND/OPEN (PWM)
14	Vacancy		GND/OPEN (PWM)
15	Battery relay energizing	Energized/De-energized	+24 V/OPEN
16	ML bypass reset	Reset/Redundancy possible	GND/OPEN
17	Solenoid cut relay energizing	Solenoid cut/Normal	GND/OPEN
18	Engine warning output	Engine abnormal/Normal	GND/OPEN
19	AIS air con. ON relay energizing	Power ON enabled/Disabled	GND/OPEN
20	Swing neutral brake selection	Neutral brake/Free	GND/OPEN
21	Sub battery relay energizing	Energized/De-energized	+24 V/OPEN
22	Vacancy		+24 V/OPEN
23	Vacancy		GND/OPEN
24	Vacancy		GND/OPEN
25	Vacancy		GND/OPEN (PWM)
26	DPR regeneration start	Manual regene. start/Normal	GND/OPEN
27	Engine restart	Start/Normal	GND/OPEN
28	Pilot pressure cut relay	Energized/De-energized	GND/OPEN
29	Fr. drum rotate detect grip (option)	凸/凹	+24 V/OPEN
30	Re. drum rotate detect grip (option)	凸/凹	+24 V/OPEN
31	Safety relay operation	Operation/Normal	GND/OPEN
32	Engine stop relay operation	Energized/De-energized	GND/OPEN
33	Swing voice alarm	ON/OFF	GND/OPEN
34	Vacancy		GND/OPEN
35	Vacancy		GND/OPEN (CPU error)
36	Vacancy		+24 V/OPEN

2. SPECIFICATIONS OF MAIN CONTROLLER 2 INPUT/OUTPUT

(1) ANALOGUE INPUT [A]

No.	Name	Range	Input voltage
1	Spare A/D		
2	Spare A/D		
3	Fr. drum motor tilt control press. sensor	0 to 2.94 MPa (30 kg/cm ²)	0.5 to 4.5 V
4	Re. drum motor tilt control press. sensor	0 to 2.94 MPa (30 kg/cm ²)	0.5 to 4.5 V
5	Third drum motor tilt control press. sensor	0 to 2.94 MPa (30 kg/cm ²)	0.5 to 4.5 V
6			
7	Fuel level	F to 1/2 to E⇒10 to 32 to 83 Ω	Grounded input (56 Ω)
8	Confluence/Independence select pressure (Fr.)	0 to 49.03 MPa (500 kg/cm ²)	0.5 to 4.5 V
9	Confluence/Independence select pressure (Re.)	0 to 49.03 MPa (500 kg/cm ²)	0.5 to 4.5 V
10			Grounded input (56 Ω)
11	Fr. • Re. drum CHP start pressure sensor	0 to 2.94 MPa (30 kg/cm ²)	0.5 to 4.5 V
12			
13			
14			
15			
16	Boom drum raise pressure sensor	0 to 2.94 MPa (30 kg/cm ²)	0.5 to 4.5 V
17	Boom drum lower pressure sensor	0 to 2.94 MPa (30 kg/cm ²)	0.5 to 4.5 V
18	Fr. drum raise pressure sensor	0 to 2.94 MPa (30 kg/cm ²)	0.5 to 4.5 V
19	Fr. drum lower pressure sensor	0 to 2.94 MPa (30 kg/cm ²)	0.5 to 4.5 V
20	Re. drum raise pressure sensor	0 to 2.94 MPa (30 kg/cm ²)	0.5 to 4.5 V
21	Re. drum lower pressure sensor	0 to 2.94 MPa (30 kg/cm ²)	0.5 to 4.5 V
22	Third drum raise pressure sensor	0 to 2.94 MPa (30 kg/cm ²)	0.5 to 4.5 V
23	Third drum lower pressure sensor	0 to 2.94 MPa (30 kg/cm ²)	0.5 to 4.5 V

10. ELECTRIC SYSTEM

(2) DIGITAL INPUT [B]

No.	Name	Status	Signal level
1	C/W detect 3		GND (15 kΩ)/OPEN
2	C/W detect 4		GND (15 kΩ)/OPEN
3	C/W detect 5 (C4, C5)		GND (15 kΩ)/OPEN
4	C/W detect 6 (C5)		GND (15 kΩ)/OPEN
5	C/W detect 7 (C5)		GND (3.3 kΩ)/OPEN
6			GND (3.3 kΩ)/OPEN
7			GND (3.3 kΩ)/OPEN
8			GND (3.3 kΩ)/OPEN
9			GND (3.3 kΩ)/OPEN
10			GND (3.3 kΩ)/OPEN
11			GND (3.3 kΩ)/OPEN
12			GND (3.3 kΩ)/OPEN
13	Crane boom overhoist signal	Normal/Overhoist	+24 V/OPEN
14	Boom B/S No. 1 signal	Normal/Overhoist	+24 V/OPEN
15	Boom B/S No. 2 signal	Normal/Overhoist	+24 V/OPEN
16			GND (3.3 kΩ)/OPEN
17			GND (3.3 kΩ)/OPEN
18	Key switch ON signal (+24 V at key ON)	ON/OFF	+24 V/OPEN
19	Function lock	Work/stop	+24 V/OPEN
20	Charge signal (alternator power generation signal)	With power generation/Without power generation	+24 V/OPEN
21	Inching selection switch	Inching/Normal	+24 V/OPEN
22			+24 V/OPEN
23			+24 V/OPEN
24	Crane hook overhoist signal	Normal/Overhoist	+24 V/OPEN
25	Jib hook overhoist signal	Normal/Overhoist	+24 V/OPEN
26	Hook overhoist release signal	Release/Normal	+24 V/OPEN
27	Boom hoisting release signal	Release/Normal	+24 V/OPEN
28	Controller ID 1		+24 V/OPEN
29	Controller ID 2		+24 V/OPEN
30	Fr. drum raise stop	Normal/Stop	+24 V/OPEN
31	Fr. drum lower stop (CEN)	Normal/Stop	+24 V/OPEN
32	Re. drum (tower jib) raise stop	Normal/Stop	+24 V/OPEN
33	Re. drum (tower jib) lower stop	Normal/Stop	+24 V/OPEN
34			+24 V/OPEN
35	Jib overhoist signal	Normal/Overhoist	+24 V/OPEN
36	C/W detect 1		GND (3.3 kΩ)/OPEN
37	C/W detect 2		GND (3.3 kΩ)/OPEN
38	Confluence/independence selection SOL (Fr. drum)		+24 V/OPEN
39	Confluence/independence selection SOL (Re. drum)		+24 V/OPEN
40	Oil cooler motor relay	ON/OFF	+24 V/OPEN
41	Third drum raise stop	Normal/Stop	+24 V/OPEN
42	Third drum lower stop	Normal/Stop	+24 V/OPEN
43	Boom drum raise stop	Normal/Stop	+24 V/OPEN
44	Boom drum lower stop	Normal/Stop	+24 V/OPEN
45	DPF load SOL	Load ON/OFF	+24 V/OPEN
46			+24 V/OPEN
47			+24 V/OPEN
48			+24 V/OPEN
49			+24 V/OPEN
50			+24 V/OPEN

No.	Name	Status	Signal level
51			+24 V/OPEN
52			+24 V/OPEN
53	ML bypass (CR)	ON/OFF	+24 V/OPEN
54	ML bypass (JIB)	ON/OFF	+24 V/OPEN
55			+24 V/OPEN
56			+24 V/OPEN
57			+24 V/OPEN
58			+24 V/OPEN

(3) ANALOGUE OUTPUT [H]

No.	Name	Status	Signal level
1			
2			

(4) PROPORTIONAL VALVE OUTPUT [D]

No.	Name	Output current	Dither
1	Boom drum raise prop. valve	200 to 625 mA	200 mAp-p 100 Hz
2	Boom drum lower prop. valve	200 to 625 mA	200 mAp-p 100 Hz
3	Fr. drum raise prop. valve	150 to 620 mA	200 mAp-p 100 Hz
4	Fr. drum lower prop. valve	150 to 620 mA	200 mAp-p 100 Hz
5	Re. drum raise prop. valve	150 to 620 mA	200 mAp-p 100 Hz
6	Re. drum lower prop. valve	150 to 620 mA	200 mAp-p 100 Hz
7	Third drum raise prop. valve (option)	150 to 620 mA	200 mAp-p 100 Hz
8	Third drum lower prop. valve (option)	150 to 620 mA	200 mAp-p 100 Hz
9	Motor CHP pressure control prop. valve	100 to 400 mA	200 mAp-p 100 Hz
10	Fr. drum motor tilt control prop. Valve	200 to 750 mA	200 mAp-p 100 Hz
11	Re. drum motor tilt control prop. valve	200 to 750 mA	200 mAp-p 100 Hz
12	Third drum motor tilt control prop. valve (option)	200 to 750 mA	200 mAp-p 100 Hz

10. ELECTRIC SYSTEM

(5) DIGITAL OUTPUT [C]

No.	Name	Output current	Dither
1			GND/OPEN
2			GND/OPEN
3			GND/OPEN
4			GND/OPEN
5			GND/OPEN
6			GND/OPEN
7			GND/OPEN (300 mA)
8			GND/OPEN (300 mA)
9			GND/OPEN (300 mA)
10			GND/OPEN
11			GND/OPEN
12			GND/OPEN
13			GND/OPEN (PWM)
14			GND/OPEN (PWM)
15	Fr. drum motor boost SOL	Boost/Normal	+24 V/OPEN
16	Oil cooler electric motor	ON/OFF	GND/OPEN
17	Confluence/independence select SOL (Fr. drum)	Confluence/independence	GND/OPEN
18	Confluence/independence select SOL (Re. drum)	Confluence/independence	GND/OPEN
19	DPF load SOL	Load ON/OFF	GND/OPEN
20			GND/OPEN
21	Re. drum motor boost SOL	Boost/Normal	+24 V/OPEN
22	Third drum motor boost SOL (option)	Boost/Normal	+24 V/OPEN
23			GND/OPEN
24			GND/OPEN
25			GND/OPEN (PWM)
26	Fr. drum control signal		GND/OPEN
27	Re. drum control signal		GND/OPEN
28	Third control signal		GND/OPEN
29	Fr. drum C/V-SOL	Energized/De-energized	+24 V/OPEN
30	Re. drum C/V-SOL	Energized/De-energized	+24 V/OPEN
31			GND/OPEN
32			GND/OPEN
33			GND/OPEN
34			GND/OPEN
35			GND/OPEN (CPU error)
36	Third C/V-SOL (option)	Energized/De-energized	+24 V/OPEN

10.3.6 ARRANGEMENT OF MAIN CONTROLLER CONNECTOR PIN

1. ARRANGEMENT OF MC1 CONNECTOR PIN

Connector No.	Pin No.	Port name	Function	Specifications	Ref.
CN101	1	+5VA	A1	Spare	
	2	GD2		Spare	
	3	TXD2		Spare	
	4	RXD2		Spare	
	5	CANH1		CAN1_H	
	6	CANL1		CAN1_L	
	7	CAN1 termination		Spare	
	8	CAN1 termination		Spare	
	9	CANH2		CAN2_H	
	10	CANL2		CAN2_L	
	11	A1		Spare	
	12	RTS		Spare	
	13	CTS		Spare	
	14	SHG2		Spare	
	15	CAN2 termination		Spare	
	16	CAN2 termination		Spare	
	17	A2	Resistance input	Spare	
	18	GA	A1	Spare	
	19	TXD1		Spare	
	20	RXD1		Spare	
	21	GD1		Spare	
	22	SHG1		Spare	
	23	TXD3		Program DL serial	
	24	RXD3			
	25	DL			
	26	GD3			
	27	GA	A2	Spare	
	28	E1+	Engine turn sensor	Spare	
	29	E1-		Spare	
	30	SHG3		Spare	
	31	H1+		Accel. indicator voltage 1+	
	32	H1-		Accel. indicator voltage 1-	
	33	H2+		Accel. indicator voltage 2+	
	34	H2-		Accel. indicator voltage 2-	

10. ELECTRIC SYSTEM

Connector No.	Pin No.	Port name	Function	Specifications	Ref.
CN102	1	+5VA	A3	Fr. drum motor speed adjusting trimmer	
	2	A3			
	3	GA	A3		
	4	+5VA	A4	Re. drum motor speed adjusting trimmer	
	5	A4			
	6	GA	A4		
	7	+5VA	A5	Third drum motor speed adjusting trimmer	
	8	A5			
	9	GA	A5		
	10	+5VA	A6	Boom drum motor speed adjusting trimmer	
	11	A6			
	12	GA	A6		
	13	A7	Resistance input	Spare	
	14	GA	A7		
	15	+5VA	A8	Grip throttle	
	16	A8			
	17	GA	A8		
	18	+5VA	A9	Foot throttle (option)	
	19	A9			
	20	GA	A9		
	21	A10	Resistance input	Hydraulic oil temperature sensor	
	22	GA	A10		

Connector No.	Pin No.	Port name	Function	Specifications	Remarks
CN103	1	+5A	A11	Tagline trimmer (option)	
	2	A11			
	3	GA	A11		
	4	+5A	A12	Control primary pressure	
	5	A12			
	6	GA	A12		
	7	+5A	A13	Swing pump pressure sensor	
	8	A13			
	9	GA	A13		
	10	+5A	A14	Swing control (right) pressure sensor	
	11	A14			
	12	GA	A22	GND for third clutch pressure sensor (option)	
	13	+5A	A15	Swing control (left) pressure sensor	
	14	A15			
	15	GA	A15		
	16	GA	A14	GND for swing control (right) pressure sensor	

Connector No.	Pin No.	Port name	Function	Specifications	Remarks
CN104	1	B1	Grounded input (15 K Ω)	ECU signal	
	2	+5A	A16	Qmax cut solenoid detection pressure	
	3	A16			
	4	GA	A16		
	5	+5A	A17	Power shift pressure sensor	
	6	A17			
	7	GA	A17		
	8	+5A	A18	+5V for supply voltage monitoring	
	9	B2	Grounded input (15 K Ω)	Engine hyd. pressure PSW	
	10	+5A	A19	+5V for Inclination sensor X	
	11	+5A	A20	+5 V for Inclination sensor Y	
	12	A18		Supply voltage monitoring	
	13	GA	A18		
	14	B3	Grounded input (15 K Ω)	CB/W detect	
	15	A19		Inclination sensor X	
	16	A20		Inclination sensor Y	
	17	GA	A20		
	18	+5A	A21	Fr. drum clutch pressure sensor	
	19	A21			
	20	GA	A21		
	21	+5A	A22	+5V for third drum clutch pressure sensor (option)	
	22	B4	Grounded input (15 K Ω)	Clogging of air cleaner	
	23	B5	Grounded input (3.3 K Ω)	Spare	
	24	GA	A19	GND for Inclination sensor X	
	25	+5A	A23	Re. drum clutch pressure sensor	
	26	A23			
	27	GA	A23		
	28	A22		Third drum clutch pressure sensor (option)	

10. ELECTRIC SYSTEM

Connector No.	Pin No.	Port name	Function	Specifications	Remarks
CN105	1	+24 V 1	Battery (+)	Power supply	
	2	+24 V		Power supply	
	3	+24 V		Power supply	
	4	B6	Grounded input (3.3 K Ω)	Fr. drum brake cooling oil temperature	
	5	B7	Grounded input (3.3 K Ω)	Re. drum brake cooling oil temperature	
	6	B8	Grounded input (3.3 K Ω)	Radiator water level	
	7	B9	Grounded input (3.3 K Ω)	Engine oil filter	
	8	GND	Battery (-)	GND	
	9	GND		GND	
	10	D10+		Tagline tension prop. valve +	
	11	D1+		Main pump horse power control prop. valve	
	12	D1-			
	13	D2+		Boom pump horse power control prop. valve	
	14	D2-			
	15	D3+		Swing low speed prop. valve	
	16	D3-			
	17	D4+		Swing counterforce prop. valve	
	18	D4-			
	19	D5+		Boom pump tilt control prop. valve	
	20	D5-			
	21	GND	Battery (-)	GND	
	22	D10-		Tagline tension prop. valve -	
	23	B10	Grounded input (3.3 K Ω)	Fr. drum control signal	
	24	B11	Grounded input (3.3 K Ω)	Re. drum control signal	
	25	B12	Grounded input (3.3 K Ω)	Third drum control signal	
	26	B13	+24 V input	Fr. drum free fall select. signal	
	27	B14	+24 V input	Re. drum free fall select. signal	
	28	B15	+24 V input	Third drum free fall select. signal	
	29	B16	Grounded input (3.3 K Ω) (and pulse input)	Fr. drum rotate sensor	
	30	B17	Grounded input (3.3 K Ω) (and pulse input)	Re. drum rotate sensor	
	31	+24 V	For backup power supply RTC		

Connector No.	Pin No.	Port name	Function	Specifications	Remarks
CN106	1	+24 V 1	Battery (+)		
	2	D6+		Fr. drum middle detent	
	3	D6-			
	4	D7+		Re. drum middle detent	
	5	D7-			
	6	D11+		Left swing stop proportional valve	
	7	D11-			
	8	D8+		Main pump tilt control prop. valve 1	
	9	D8-			
	10	D9+		Main pump tilt control prop. valve 2	
	11	D9-			
	12	B18	+24 V input	Key SW ON signal	
	13	B19	+24 V input	Function lock	
	14	B20	+24 V input	Charge signal	
	15	D12+		Right swing stop proportional valve	
	16	D12-			
	17	GND	Battery (-)	Spare	
	18	B21	+24 V input	Inching selection	
	19	B22	+24 V input	Aux. accel. signal	
	20	B23	+24 V input	Engine emg. stop signal	
	21	B24	+24 V input	Engine restart	
	22	B25	+24 V input	Operator certificate wait signal	
	23	B26	+24 V input	Swing parking switch	
	24	B27	+24 V input	Drum rotate detecting grip selection	

10. ELECTRIC SYSTEM

Connector No.	Pin No.	Port name	Function	Specifications	Remarks
CN107	1	B28	D/O FB	Controller ID 1	
	2	B29	D/O FB	Controller ID 2	
	3	B30	+24 V input	G mode/Normal selection	
	4	B31	+24 V input	G winch (Fr.)	
	5	B32	+24 V input	G winch (Re.)	
	6	B33	+24 V input	G winch (main)	
	7	B34	D/O FB	AIS function ON/OFF SW	
	8	B35	+24 V input	Propel control pressure switch	
	9	B36	Grounded input (3.3 K Ω) (and pulse input)	Spare	
	10	B37	Grounded input (3.3 K Ω) (and pulse input)	Cooling line filter	
	11	B38	+24 V input	Engine preheat	
	12	B39	+24 V input	Spare	
	13	B40	D/O FB	Backup fuse	
	14	B41	+24 V input	Fr. drum free fall speed increase SW	
	15	B42	+24 V input	Re. drum free fall speed increase SW	
	16	B43	+24 V input	Third drum free fall speed increase SW (option)	
	17	B44	+24 V input	Free fall permit signal	

Connector No.	Pin No.	Port name	Function	Specifications	Remarks
CN108	1	C1	Grounded output	Fr. drum motor CLM-SOL	
	2	C2	Grounded output	Fr. drum motor ESM-SOL	
	3	C3	Grounded output	Re. drum motor CLA-SOL	
	4	C4	Grounded output	Re. drum motor ESA-SOL	
	5	C5	Grounded output	Third drum motor CLT-SOL	
	6	B45	D/O FB	Fr. drum motor CLM-SOL (FB)	
	7	B46	D/O FB	Fr. drum motor ESM-SOL (FB)	
	8	B47	D/O FB	Re. drum motor CLA-SOL (FB)	
	9	B48	D/O FB	Re. drum motor ESA-SOL (FB)	
	10	C6	Grounded output	Third drum motor EST-SOL	
	11	C7	Grounded output	Spare	
	12	C8	Grounded output	Swing parking control	
	13	C9	Grounded output	ML adjust. mode selection	
	14	C10	Grounded output	Hyd. oil heat SOL	
	15	B49	D/O FB	Third motor CLT-SOL (FB)	
	16	B50	D/O FB	Third motor EST-SOL (FB)	
	17	B51	D/O FB	Hyd. oil heat LS(option)	
	18	B52	D/O FB	Pump Qmax cut solenoid (FB)	
	19	B53	D/O FB	Remote control connection signal	
	20	C11	Grounded output	Pump Qmax cut solenoid	
	21	C12	Grounded output	Swing flasher	
	22	C13	PWM output	Spare	
	23	C14	PWM output	Spare	
	24	B54	D/O FB	Swing warning (flasher)	
	25	B55	D/O FB	Swing warning (Buzzer and flasher)	
	26	B56	D/O FB	DPF regeneration (FB)	
	27	B57	D/O FB	Accel. signal (DOWN)	
	28	B58	D/O FB	Accel. signal (UP)	

10. ELECTRIC SYSTEM

Connector No.	Pin No.	Port name	Function	Specifications	Remarks
CN109	1	C15	+24 V output	Battery relay energizing	
	2	C16	Grounded output	ML bypass reset	
	3	C17	Grounded output	Solenoid cut relay energizing	
	4	C18	Grounded output	Engine warning output	
	5	C19	Grounded output	AIS air con. ON relay energizing	
	6	C20	Grounded output	Swing neutral brake selection	
	7	C21	+24 V output	Sub battery relay energizing	
	8	C22	+24 V output	Spare	
	9	C23	Grounded output	Spare	
	10	C24	Grounded output	Spare	
	11	C25	PWM output	Spare	
	12	C26	Grounded output	DPF regeneration start	
	13	C27	Grounded output	Engine restart	
	14	C28	Grounded output	Pilot pressure cut relay	
	15	C29	+24 V output	Fr. drum rotate detection grip (option)	
	16	C30	+24 V output	Re. drum rotate detection grip (option)	
	17	C31	Grounded output	Safety relay operation	
	18	C32	Grounded output	Engine stop relay operation	
	19	C33	Grounded output	Swing voice alarm	
	20	C34	Grounded output	Spare	
	21	C35	Grounded output	Spare	
	22	C36	+24 V output	Spare	

2. ARRANGEMENT OF MC2 CONNECTOR PIN

Connector No.	Pin No.	Port name	Function	Specifications	Ref.
CN111	1	+5VA	A1	Vacancy	
	2	GD2		Vacancy	
	3	TXD2		Vacancy	
	4	RXD2		Vacancy	
	5	CANH1		CAN1_H	
	6	CANL1		CAN1_L	
	7	CAN1 termination		Vacancy	
	8	CAN1 termination		Vacancy	
	9	CANH2		CAN2_H	
	10	CANL2		CAN2_L	
	11	A1		Vacancy	
	12	RTS		Vacancy	
	13	CTS		Vacancy	
	14	SHG2		Vacancy	
	15	CAN2 termination		Vacancy	
	16	CAN2 termination		Vacancy	
	17	A2	Resistance input	Vacancy	
	18	GA	A1	Vacancy	
	19	TXD1		Vacancy	
	20	RXD1		Vacancy	
	21	GD1		Vacancy	
	22	SHG1		Vacancy	
	23	TXD3		Program DL serial	
	24	RXD3			
	25	DL			
	26	GD3			
	27	GA	A2	Vacancy	
	28	E1+	Engine rotate sensor	Vacancy	
	29	E1-		Vacancy	
	30	SHG3		Vacancy	
	31	H1+		Vacancy	
	32	H1-		Vacancy	
	33	H2+		Vacancy	
	34	H2-		Vacancy	

10. ELECTRIC SYSTEM

Connector No.	Pin No.	Port name	Function	Specifications	
CN112	1	+5VA	A3	Fr. drum motor tilt control pressure sensor	
	2	A3			
	3	GA	A3		
	4	+5VA	A4	Re. drum motor tilt control pressure sensor	
	5	A4			
	6	GA	A4		
	7	+5VA	A5	Third drum motor tilt control pressure sensor	
	8	A5			
	9	GA	A5		
	10	+5VA	A6	A/D spare	
	11	A6			
	12	GA	A6		
	13	A7	Resistance input	Fuel level	
	14	GA	A7		
	15	+5VA	A8	Confluence/Independence selection pressure (Fr. drum)	
	16	A8			
	17	GA	A8		
	18	+5VA	A9	Confluence/Independence selection pressure (Re. drum)	
	19	A9			
	20	GA	A9		
	21	A10	Resistance input	A/D spare	
	22	GA	A10		

Connector No.	Pin No.	Port name	Function	Specifications	
CN113	1	+5A	A11	Fr./Re. drum CHP start pressure sensor	
	2	A11			
	3	GA	A11		
	4	+5A	A12	A/D spare	
	5	A12			
	6	GA	A12		
	7	+5A	A13	A/D spare	
	8	A13			
	9	GA	A13		
	10	+5A	A14	A/D spare	
	11	A14			
	12	GA	A22	Third drum raise pressure sensor	
	13	+5A	A15	A/D spare	
	14	A15			
	15	GA	A15		
	16	GA	A14	A/D spare	

Connector No.	Pin No.	Port name	Function	Specifications	
CN114	1	B1	Grounded input (15 K Ω)	C/W detect 3	
	2	+5A	A16	Boom drum raise pressure sensor	
	3	A16			
	4	GA	A16		
	5	+5A	A17	Boom drum lower pressure sensor	
	6	A17			
	7	GA	A17		
	8	+5A	A18	Fr. drum raise pressure sensor	
	9	B2	Grounded input (15 K Ω)	C/W detect 4	
	10	+5A	A19	Fr. drum lower pressure sensor	
	11	+5A	A20	Re. drum raise pressure sensor	
	12	A18	A18	Fr. drum raise pressure sensor	
	13	GA			
	14	B3	Grounded input (15 K Ω)	C/W detect 5 (C4, C5)	
	15	A19		Fr. drum lower pressure sensor	
	16	A20	A20	Re. drum raise pressure sensor	
	17	GA			
	18	+5A	A21	Re. drum lower pressure sensor	
	19	A21			
	20	GA	A21		
	21	+5A	A22	Third drum raise pressure sensor	
	22	B4	Grounded input (15 K Ω)	C/W detect 6 (C5)	
	23	B5	Grounded input (3.3 K Ω)	C/W detect 7 (C5)	
	24	GA	A19	Fr. drum lower pressure sensor	
	25	+5A	A23	Third drum lower pressure sensor	
	26	A23			
	27	GA	A23		
	28	A22		Third drum raise pressure sensor	

10. ELECTRIC SYSTEM

Connector No.	Pin No.	Port name	Function	Specifications		
CN115	1	+24 V 1	Battery (+)	Power supply		
	2	+24 V		Power supply		
	3	+24 V		Power supply		
	4	B6	Grounded input (3.3 K Ω)	Fr. drum brake cooling oil temperature		
	5	B7	Grounded input (3.3 K Ω)	Re. drum brake cooling oil temperature		
	6	B8	Grounded input (3.3 K Ω)	Radiator water level		
	7	B9	Grounded input (3.3 K Ω)	Engine oil filter		
	8	GND	Battery (-)	GND		
	9	GND		GND		
	10	D10+		Fr. drum motor tilt control prop. valve +		
	11	D1+		Boom drum raise proportional valve		
	12	D1-				
	13	D2+		Boom drum lower proportional valve		
	14	D2-				
	15	D3+		Fr. drum raise proportional valve		
	16	D3-				
	17	D4+		Fr. drum lower proportional valve		
	18	D4-				
	19	D5+		Re. drum raise proportional valve		
	20	D5-				
	21	GND	Battery (-)	GND		
	22	D10-		Fr. drum motor tilt control prop. valve -		
	23	B10	Grounded input (3.3 K Ω)	Spare		
	24	B11	Grounded input (3.3 K Ω)	Spare		
	25	B12	Grounded input (3.3 K Ω)	Spare		
	26	B13	+24 V input	Crane boom overhoist signal		
	27	B14	+24 V input	Boom B/S No.1 signal		
	28	B15	+24 V input	Boom B/S No.2 signal		
	29	B16	Grounded input (3.3 K Ω) (and pulse input)	Spare		
	30	B17	Grounded input (3.3 K Ω) (and pulse input)	Spare		
	31	+24 V	For backup power supply RTC	Power supply		

Connector No.	Pin No.	Port name	Function	Specifications	Remarks
CN116	1	+24 V 1	Battery (+)	Power supply	
	2	D6+		Re. drum lower proportional valve	
	3	D6-			
	4	D7+		Third drum raise proportional valve (option)	
	5	D7-			
	6	D11+		Re. drum motor tilt control prop. valve	
	7	D11-			
	8	D8+		Third drum lower prop. valve (option)	
	9	D8-			
	10	D9+		Motor CHP pressure control prop. valve	
	11	D9-			
	12	B18	+24 V input	Key SW ON signal	
	13	B19	+24 V input	Function lock	
	14	B20	+24 V input	Charge signal	
	15	D12+		Third drum motor tilt control prop. valve (option)	
	16	D12-			
	17	GND	Battery (-)	Spare	
	18	B21	+24 V input	Inching selection	
	19	B22	+24 V input	Spare	
	20	B23	+24 V input	Spare	
	21	B24	+24 V input	Crane hook overhoist signal	
	22	B25	+24 V input	Jib hook overhoist signal	
	23	B26	+24 V input	Hook overhoist release signal	
	24	B27	+24 V input	Boom overhoist release signal	

10. ELECTRIC SYSTEM

Connector No.	Pin No.	Port name	Function	Specifications	Remarks
CN117	1	B28	D/O FB	Controller ID 1	
	2	B29	D/O FB	Controller ID 2	
	3	B30	+24 V input	Fr. drum raise stop	
	4	B31	+24 V input	Fr. drum lower stop	
	5	B32	+24 V input	Re. drum (tower jib) raise stop	
	6	B33	+24 V input	Re. drum (tower jib) lower stop	
	7	B34	D/O FB	Spare	
	8	B35	+24 V input	Jib overhoist signal	
	9	B36	Grounded input (3.3 K Ω) (and pulse input)	C/W detect 1	
	10	B37	Grounded input (3.3 K Ω) (and pulse input)	C/W detect 2	
	11	B38	+24 V input	Confluence/Independence selection solenoid (Fr.)	
	12	B39	+24 V input	Confluence/Independence selection solenoid (Re.)	
	13	B40	D/O FB	Oil cooler motor relay	
	14	B41	+24 V input	Third drum raise stop	
	15	B42	+24 V input	Third drum lower stop	
	16	B43	+24 V input	Boom drum raise stop	
	17	B44	+24 V input	Boom drum lower stop	

Connector No.	Pin No.	Port name	Function	Specifications	Remarks
CN118	1	C1	Grounded output	Spare	
	2	C2	Grounded output	Spare	
	3	C3	Grounded output	Spare	
	4	C4	Grounded output	Spare	
	5	C5	Grounded output	Spare	
	6	B45	D/O FB	DPF load solenoid	
	7	B46	D/O FB	Spare	
	8	B47	D/O FB	Spare	
	9	B48	D/O FB	Spare	
	10	C6	Grounded output	Spare	
	11	C7	Grounded output	Spare	
	12	C8	Grounded output	Spare	
	13	C9	Grounded output	Spare	
	14	C10	Grounded output	Spare	
	15	B49	D/O FB	Spare	
	16	B50	D/O FB	Spare	
	17	B51	D/O FB	Spare	
	18	B52	D/O FB	Spare	
	19	B53	D/O FB	ML bypass (CR)	
	20	C11	Grounded output	Spare	
	21	C12	Grounded output	Spare	
	22	C13	PWM output	Spare	
	23	C14	PWM output	Spare	
	24	B54	D/O FB	ML bypass (JIB)	
	25	B55	D/O FB	Spare	
	26	B56	D/O FB	Spare	
	27	B57	D/O FB	Spare	
	28	B58	D/O FB	Spare	

10. ELECTRIC SYSTEM

Connector No.	Pin No.	Port name	Function	Specifications	Remarks
CN119	1	C15	+24 V output	Fr. drum motor boost SOL	
	2	C16	Grounded output	Oil cooler electric motor	
	3	C17	Grounded output	Confluence/Independence selection solenoid (Fr. drum)	
	4	C18	Grounded output	Confluence/Independence selection solenoid (Re. drum)	
	5	C19	Grounded output	DPF load solenoid	
	6	C20	Grounded output	Spare	
	7	C21	+24 V output	Re. drum motor boost SOL	
	8	C22	+24 V output	Third motor boost SOL (option)	
	9	C23	Grounded output	Spare	
	10	C24	Grounded output	Spare	
	11	C25	PWM output	Spare	
	12	C26	Grounded output	Fr. drum control signal	
	13	C27	Grounded output	Re. drum control signal	
	14	C28	Grounded output	Third drum control signal	
	15	C29	+24 V output	Fr. drum C/V-SOL	
	16	C30	+24 V output	Re. drum C/V-SOL	
	17	C31	Grounded output	Spare	
	18	C32	Grounded output	Spare	
	19	C33	Grounded output	Spare	
	20	C34	Grounded output	Spare	
	21	C35	Grounded output	Spare	
	22	C36	+24 V output	Third C/V-SOL (option)	

10.3.7 ADJUSTMENT OF MAIN CONTROLLER

1. Model number setting

Perform this setting only when controller is replaced.

If model setting is not properly done, machine does not work properly.

Take extra care.

(1) Turn the engine key ON.

(2) Select the screen as follows.

Main screen (a) → (b) → Password input
 → MC adjustment → Model number setting

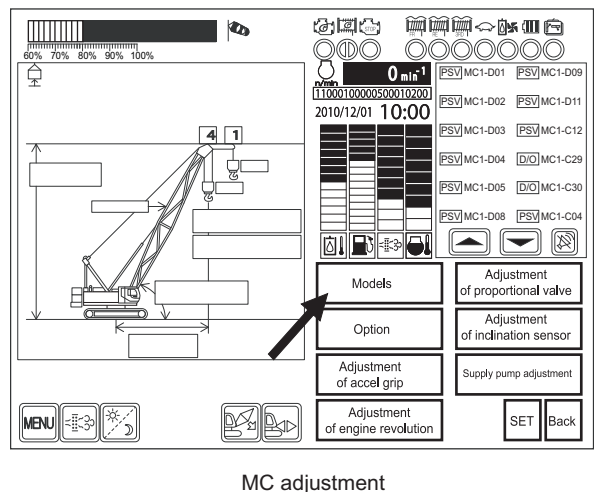
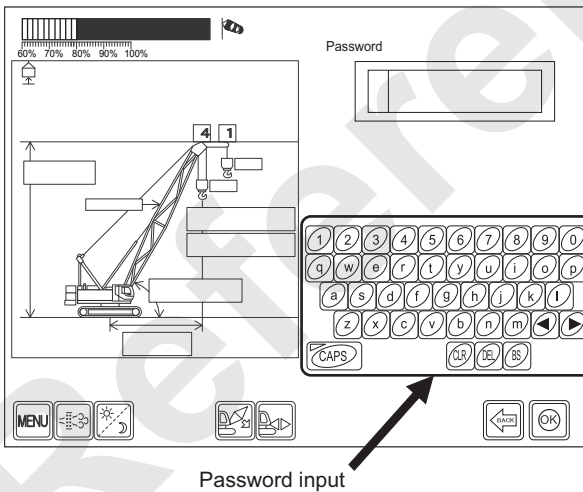
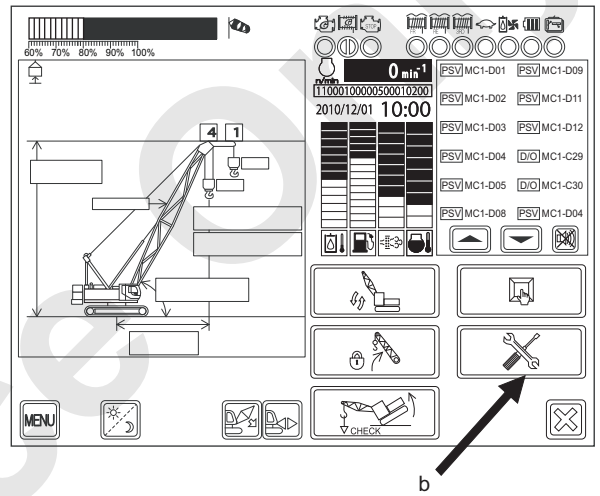
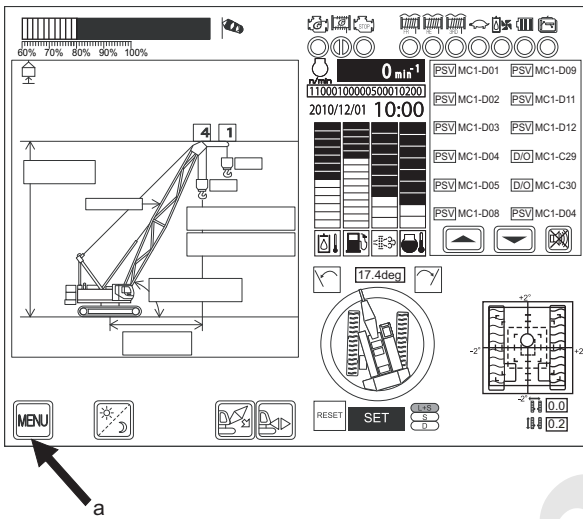

10. ELECTRIC SYSTEM

- (3) Select the indicated model group.
- (4) Push "OK" after model group is selected.
Unless "OK" is pushed, selection becomes ineffective.

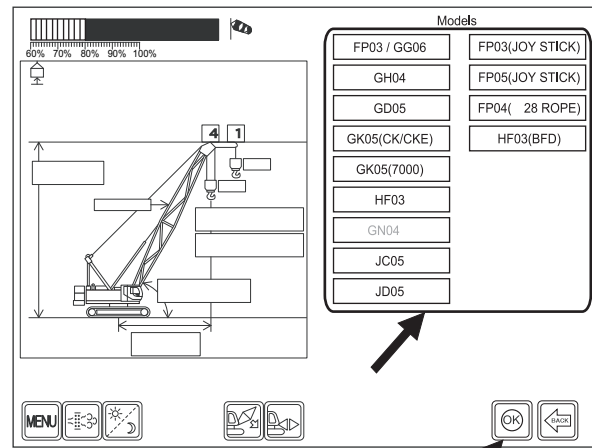

2. Option setting

- (1) Turn the engine key "ON".
- (2) Select the screen as follows.
Main screen (a) → (b) → Password input
→ MC adjustment → Option setting
- (3) Select "O" (yes) or "X" (no) on each function setting.
Use (c) icon for page change.
- (4) After setting is completed, push "OK" and after page is changed, push "SET" to record.
Unless "SET" is pushed, selection becomes ineffective.

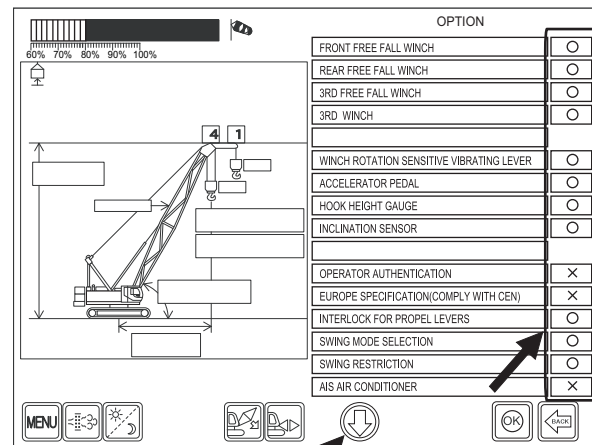

c

3. Adjustment of grip throttle and foot throttle.

- (1) Turn the engine key "ON".
- (2) Select the screen as follows.
Main screen (a) → (b) → Password input
→ MC adjustment → Grip adjustment
- (3) The screen changes to adjustment screen.
Push adjustment start button (d).
- (4) Throttle low adjustment.
Set the grip throttle and foot throttle to low idle position.
- (5) If OK, push button (d).
- (6) Throttle high adjustment.
Set the grip throttle and foot throttle to high idle position.
- (7) If OK, push button (d).
- (8) If adjustment completion becomes indicated, push "OK" and push "SET" after screen has been changed to record.
Unless "SET" is pushed, selection becomes ineffective.

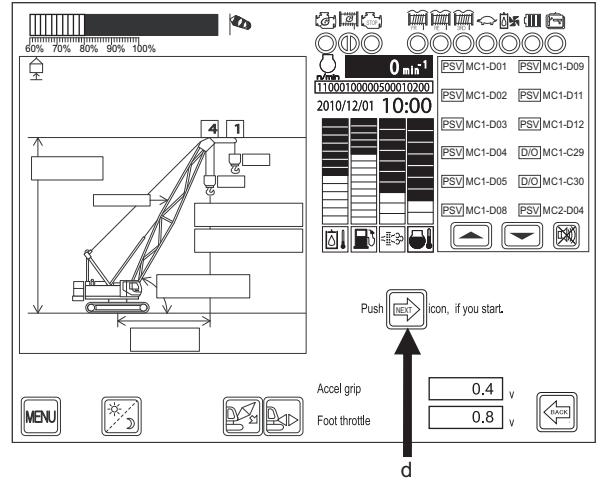

4. Engine speed adjustment

Warm up the engine sufficiently before adjustment.

- (1) Start the engine and select the screen as follows.
Main screen (a) → (b) → Password input
→ MC adjustment → Engine speed adjustment
- (2) The screen changes to adjustment screen.
Push adjustment start button if OK.
- (3) Engine speed is raised to high idle once and then gradually lowered to low idle.
- (4) If adjustment completion becomes indicated, push "OK" and push "SET" after screen has been changed to record.
Unless "SET" is pushed, selection becomes ineffective.

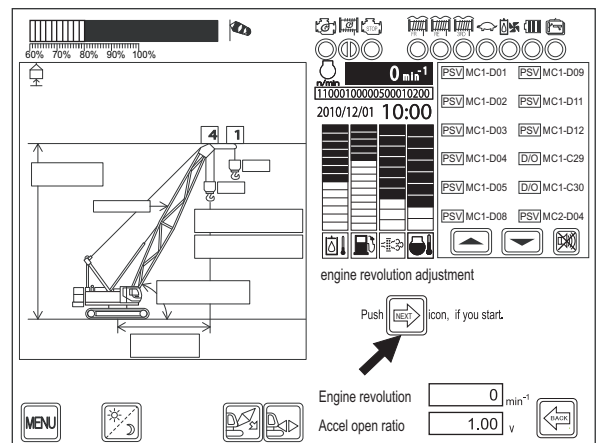

If adjustment becomes NG,

NG 1 :

Engine speed is abnormal.

Check if engine error is output.

NG 2 :

Transmission is error.

10. ELECTRIC SYSTEM

5. Adjusting of inclination meter

Place the main machinery on the horizontal ground before adjustment using the level gauge etc.

- (1) Turn the engine key ON.
- (2) Select the screen as follows.
Main screen (a) → (b) → Password input
→ MC adjustment → Inclination meter adjustment
- (3) The screen changes to adjustment screen.
Push adjustment start button "SET" if OK.
- (4) If adjustment completion becomes indicated, push "OK" and push "SET" after screen has been changed to record.
Unless "SET" is pushed, selection becomes ineffective.

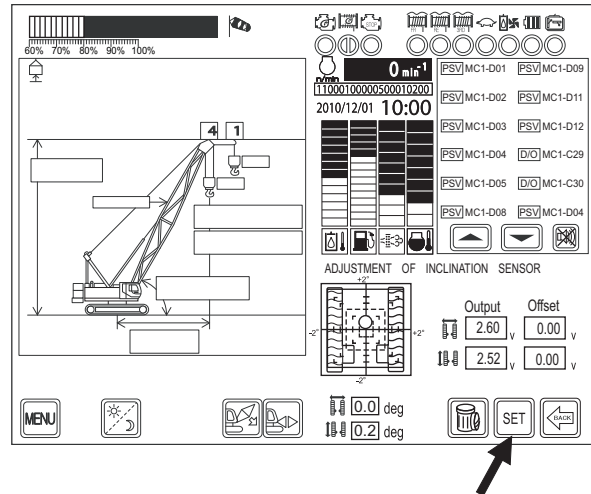

6. Supply pump adjustment

This adjustment is not normally used.
Perform this adjustment only when engine supply pump is replaced.
If this is used other than supply pump replacement, it would affect the engine performance.
Take extra care.

- (1) After replacement of supply pump, start the engine and select the screen as follows.
Main screen (a) → (b) → Password input
→ MC adjustment → Pump learning function
- (2) Engine speed stays in low idle. Push (e).
- (3) Progress becomes indicated.
100% is reached after 5 minutes.

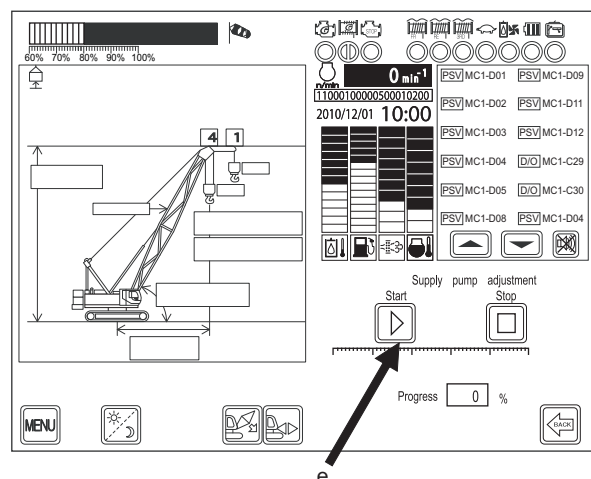

10.3.8 CONTROLLER MALFUNCTION EMERGENCY MEASURES

When the controller is malfunctioned, as an emergency measure, set the BYPASS switch for the main controller in the left side stand to the "bypass" position.

The crane operation becomes possible.

Automatic stop is actuated by the load safety device even when the BYPASS switch is actuated.

The variable speed function with the drum speed control knob is unavailable during the crane operation using the BYPASS switch.

Malfunction of the proportional valves (D5, D8, D9, D11, D12 in MC1 and D1 to D8 in MC2) will be displayed in the cluster gauge.

(excluding the case when H-1 is displayed)

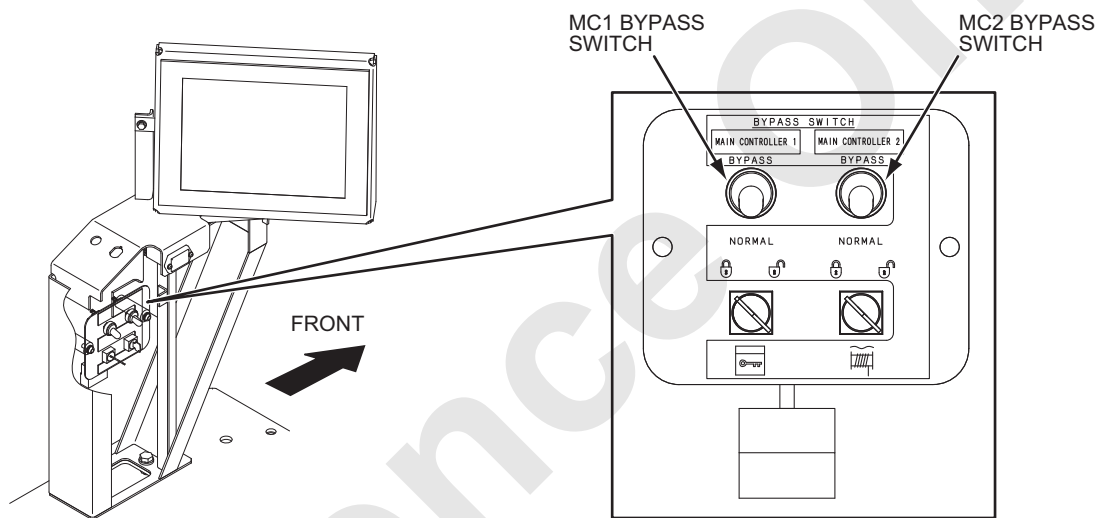

Reference Only

11. AIR CONDITIONER

Reference Only

Reference Only

11.1 AIR CONDITIONER

1. NAME OF THE AIR CONDITIONER PARTS

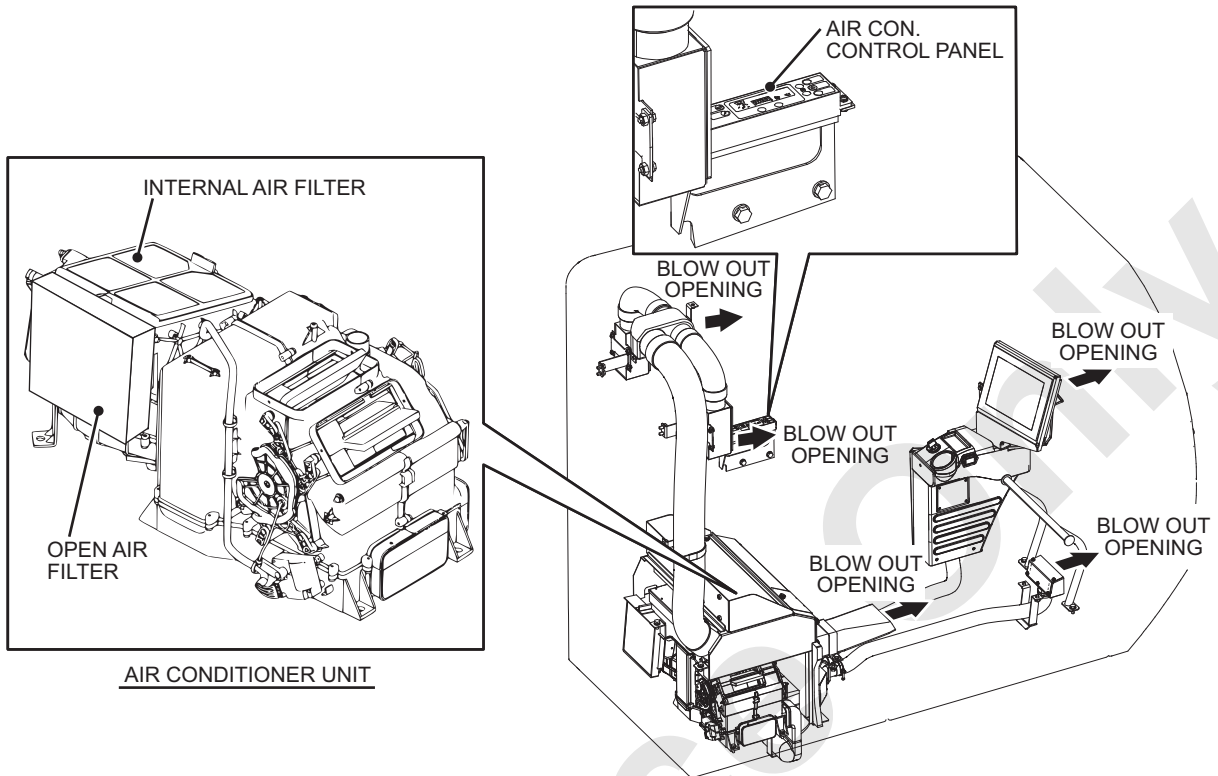

2. NAME OF THE CONTROL PANEL

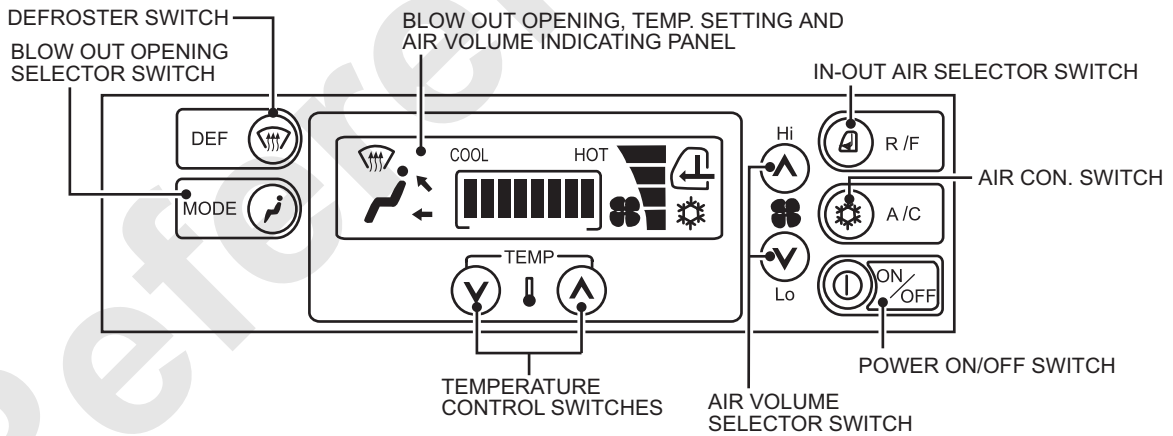

11. AIR CONDITIONER

3. FUNCTION OF EACH CONTROL

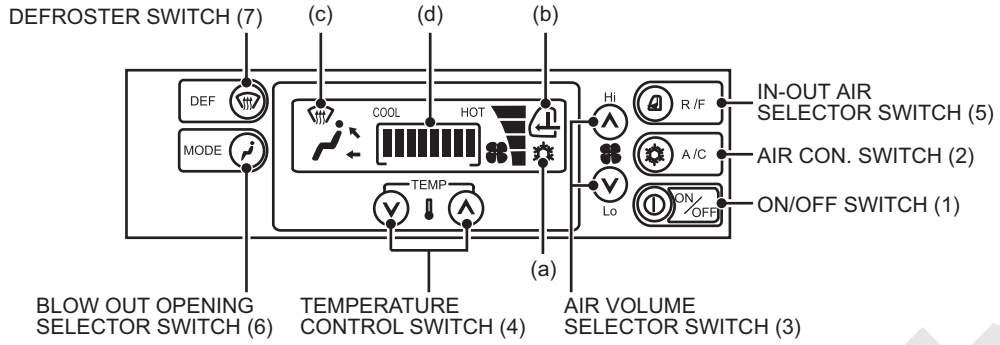

(1) ON/OFF SWITCH (POWER SWITCH)

It turns ON or OFF the air conditioner. When this switch is pushed, air conditioner starts with previous set mode.

When this switch is pushed at the first time, the air conditioner starts on factory set mode.

(2) AIR CON. SWITCH (AIR CONDITIONER SWITCH)

Every time when this switch is pushed, the air compressor alternates ON/OFF.

When the air conditioner is ON, lights up on the LCD display (a).







(a) SWITCH "ON" INDICATION

(3) AIR VOLUME SELECTOR SWITCH (FAN SWITCH)

Air volume can be changed by pushing this switch and is indicated on the LCD display when air conditioner is running.

Pushing  increase air volume.

Pushing  decrease air volume.

LCD DISPLAY				
AIR VOLUME	LOW	MEDIUM LOW	MEDIUM HIGH	HIGH

(4) TEMPERATURE CONTROL SWITCH (AIR CONDITIONER TEMP. SET)

Pushing this switch changes temperature setting when the air conditioner is running.

Set temperature (d) is indicated on LCD display.

Pushing  rises temperature (blowing air temp.)

Pushing  lowers temperature (blowing air temp.)



(d) INDICATION CONTENT

**(5) IN-OUT AIR SELECTOR SWITCH
(R/F SWITCH)**

Every time when this switch is pushed, internal air / open air alternate and it is indicated (b) on LCD display.

 internal air circulation

 out air take in



(b) INDICATION CONTENT

**(6) BLOW OUT OPENING SELECTOR SWITCH
(MODE SWITCH)**

Every time when this switch is pushed, blow out opening changes on the following sequence.

Vent → Bi-level → Foot → Vent

They are indicated as shown below.

LCD display			
Blow out opening	Vent	Bi level	Foot
Blow out direction	Upper rear	Upper rear and foot	Foot / *windscreen

* Air blows from DEF too.
Blow volume is Foot > DEF.

**(7) DEFROSTER SWITCH
(DEF SWITCH)**

Every time when this switch is pushed, blow out opening changes to DEF and is indicated (c) on the LCD display.

This is to defog on the inner side of the front glass or to defrost on the outer side of the front glass.

(c) LCD display	
Blow out opening	DEF
Blow out direction	windscreen and *foot

* Air also blows from DEF.
Blow volume is Foot < DEF.

11. AIR CONDITIONER

4. AIR CONDITIONER CONTROL

(1) To stop or to start air conditioner :

Push ON/OFF SWITCH (1).

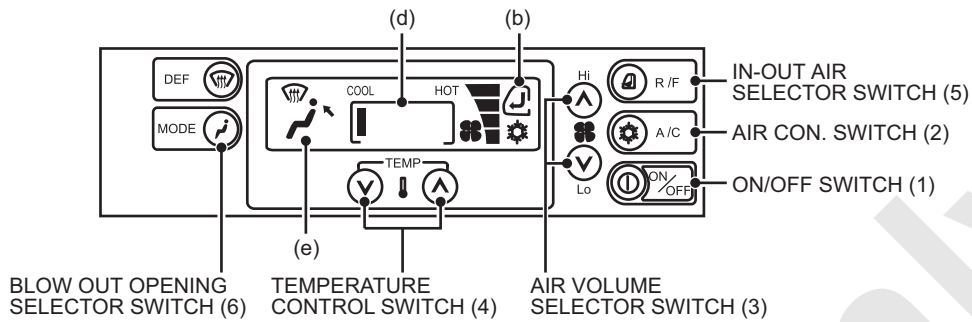

(2) To cool :

(A) Push AIR CON. SWITCH (2).

(B) Push the TEMPERATURE CONTROL SWITCH (4) to indicate on the LCD display.



(d) TEMPERATURE CONTROL INDICATION

(C) Push the AIR VOLUME SELECTOR SWITCH (3) for required air volume setting position.

(D) Push BLOW OUT OPENING SELECTOR SWITCH (6) for VENT position (e).
(Vent position is recommended in this case.)



(e) VENT

(E) By pushing IN-OUT AIR SELECTOR SWITCH (5), set the selector to internal air circulation (b) (recommended position in this case)
If air con. cools down too low, adjust the temp. by TEMPERATURE CONTROL SWITCH (4) or adjust the air volume by AIR VOLUME SELECTOR SWITCH (3) or both.



(b) INTERNAL AIR CIRCULATION

- If AIR CON. SWITCH (2) is not pushed, air con. does not cool but only air flows.
- While defrosting the windscreen do not set the temperature to max. cooling.
- Cold air may make windscreen foggy from outside and it may disturb the operator's vision.

(3) To warm :

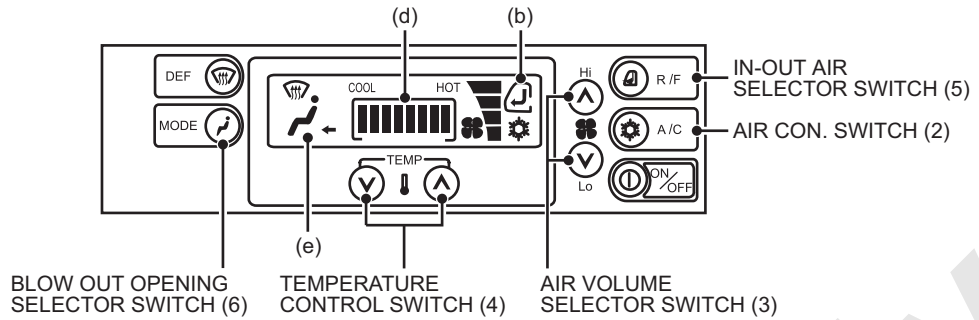

(A) Push the TEMPERATURE CONTROL SWITCH (4) to indicate on the LCD display.



(d) TEMPERATURE CONTROL INDICATION

(B) Push the AIR VOLUME SELECTOR SWITCH (3) for required air volume.

(C) Push BLOW OUT OPENING SELECTOR SWITCH (6) for FOOT position (e).
(Foot position is recommended in this case.)



(e) FOOT

(D) By pushing IN-OUT AIR SELECTOR SWITCH (5), set the selector to internal air circulation (b).
(Recommended position in this case.)
If air con. warms up too high, adjust the temp. by TEMPERATURE CONTROL SWITCH (4) or adjust the air volume by AIR VOLUME SELECTOR SWITCH (3) or both.



(b) INTERNAL AIR CIRCULATION

- If AIR CON. SWITCH (2) is pushed, air con. operates on dry air warming
- If blow out selector switch is on Foot position, air blow out from defroster too.

11. AIR CONDITIONER

(4) To defrost on the windscreen :

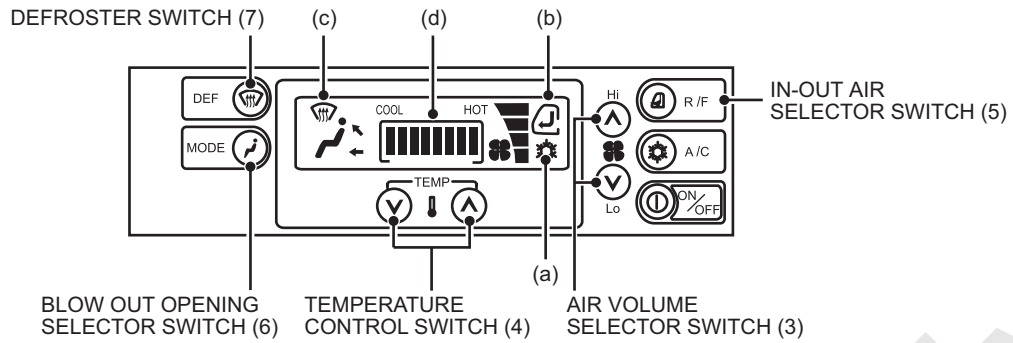

(A) Push the TEMPERATURE CONTROL SWITCH (4) to indicate (d) on the LCD display.



(d) TEMPERATURE CONTROL INDICATION

(B) Push the AIR VOLUME SELECTOR SWITCH (3) for HIGH air volume.

(C) Push DEFROSTER SWITCH (7) to change the blow out opening to DEF position (c).



(c) DEF

(D) By pushing IN-OUT AIR SELECTOR SWITCH (5), set the selector to internal air circulation (b).



(b) INTERNAL AIR CIRCULATION

- By pushing BLOW OUT OPENING SELECTOR SWITCH (6), blow out opening returns to the set opening before DEFROSTER SWITCH (7) is pushed.
- If blow out opening is set to DEF, air blows to foot too.

(5) To defog on the windscreen :

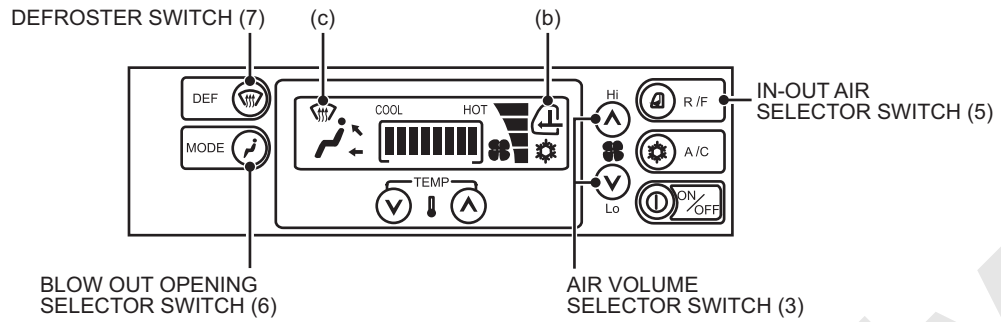

(A) Push the AIR VOLUME SELECTOR SWITCH (3) for required air volume.

(B) Push the DEFROSTER SWITCH (7) to change the blow out opening to DEF position (c).



(c) DEF

(C) By pushing IN-OUT AIR SELECTOR SWITCH (5), set the selector to out air take in.



(b) OUT AIR TAKE IN

- If quick defogging is required, set the air volume to HIGH by AIR VOLUME SELECTOR SWITCH (3).
- By pushing BLOW OUT OPENING SELECTOR SWITCH (6), blow out opening returns to the set opening before DEFROSTER SWITCH (7) is pushed.

Referer

This page is blank for editing convenience.

11.2 PARTS ILLUSTRATION

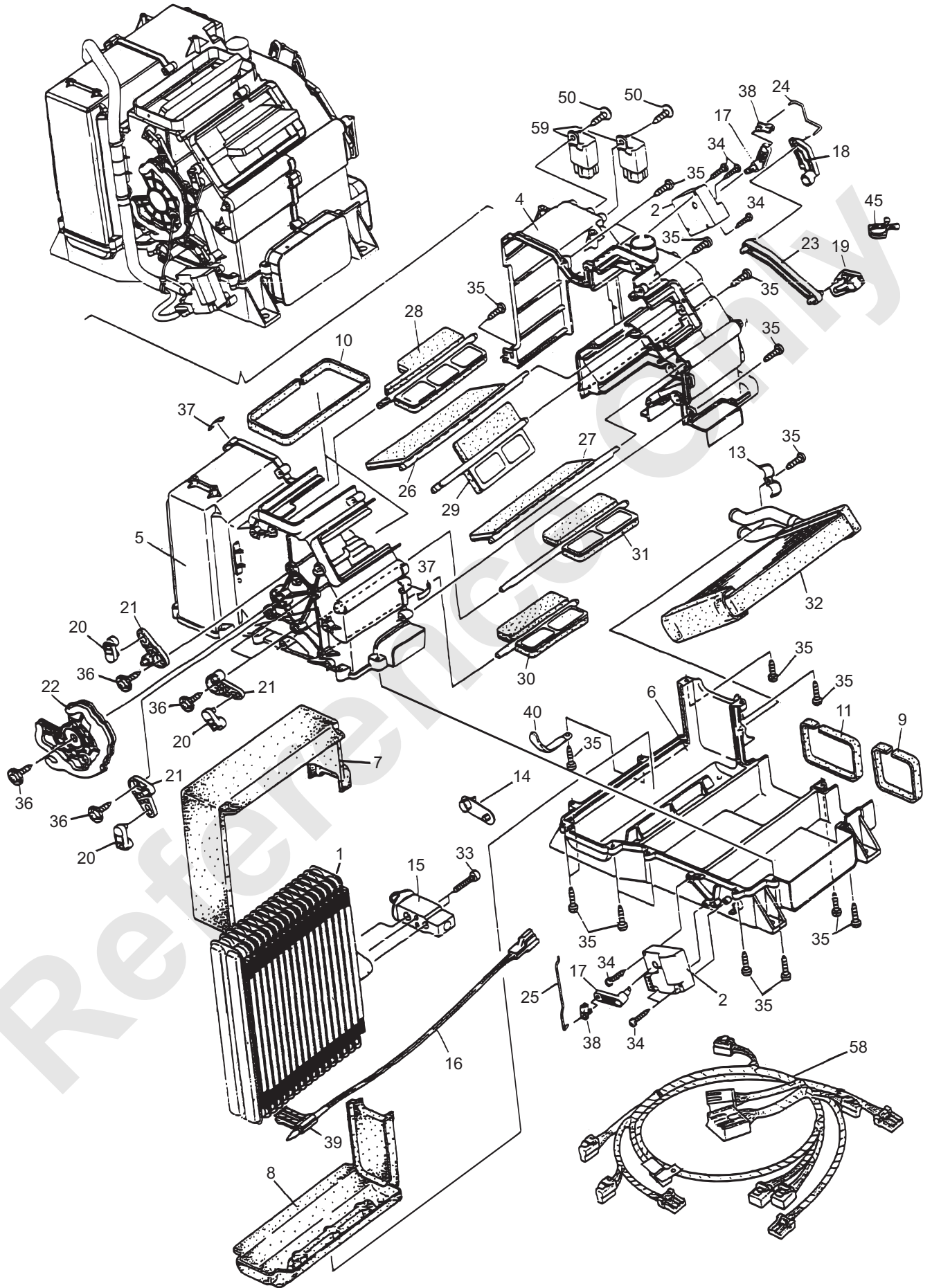

11. AIR CONDITIONER

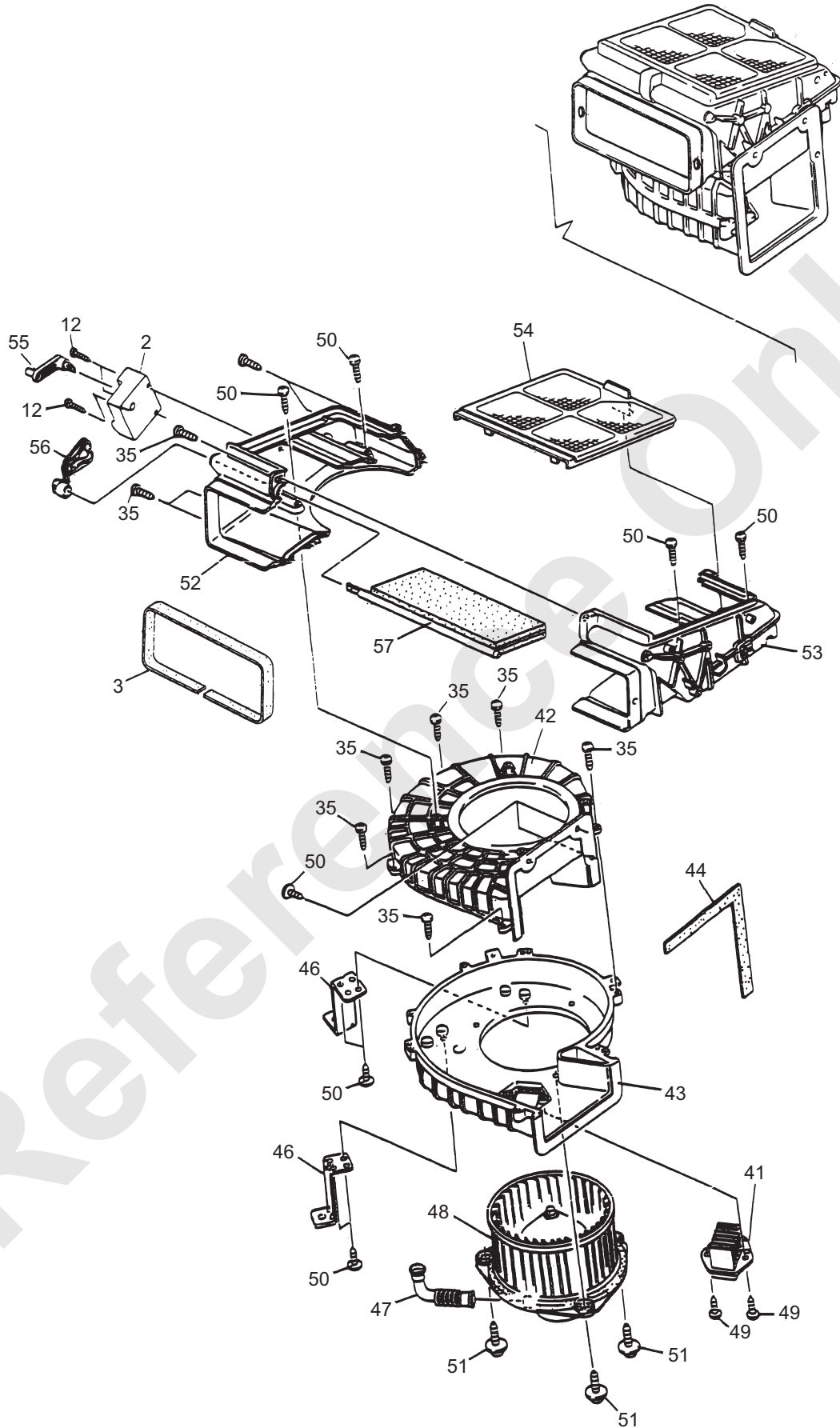

1. EVAPORATOR
2. ACTUATOR
3. OUT AIR INTAKE PACKING
4. FRONT UNIT CASE
5. REAR UNIT CASE
6. LOWER UNIT CASE
7. CASE INSULATION (UPPER)
8. CASE INSULATION (LOWER)
9. DUCT PACKING
10. DUCT PACKING
11. DUCT PACKING
12. TAPPING SCREW
13. PIPE CLAMP
14. EXPANSION VALVE
16. THERMISTOR
17. LEVER (MAL1)
18. LEVER (AM)
19. LEVER (CM)
20. LEVER (MO1)
21. LEVER (MO2)
22. MODE CAM
23. ROD AC
24. AM ROD
25. MODE ROD
26. DAMPER AM ASSY
27. DAMPER CM ASSY
28. DAMPER VE ASSY
29. DAMPER FA ASSY
30. DAMPER DE ASSY
31. DAMPER FO ASSY
32. HEATER CORE ASSY
33. HEX. SOCKET HEAD SCREW
34. TAPPING SCREW
35. TAPPING SCREW
36. TAPPING SCREW
37. CLAMP
38. ROD HOLDER
39. SENSOR HOLDER
40. CORD CLAMP A
41. FAN DRIVER
42. UPPER BLOWER CASE
43. LOWER BLOWER CASE
44. BLOWER PACKING
45. CORD CLAMP
46. UNIT BRACKET
47. UNIT COOLING HOSE
48. BLOWER MOTOR (29V)
49. TAPPING SCREW
50. TAPPING SCREW
51. TAPPING SCREW
52. INTAKE CASE (R)
53. INTAKE CASE (L)
54. INTERNAL AIR FILTER
55. LEVER (MAL2)
56. LEVER (IN)
57. DAMPER (IN) ASSY
58. UNIT HARNESS ASSY
59. RELAY

11.3 DISASSEMBLY AND ASSEMBLY OF THE UNIT

11.3.1 REMOVAL OF THE BLOWER UNIT

1. Remove the various connectors attached to the in-out air motor actuator, blower motor and blower controller and harnesses attached to the blower case.

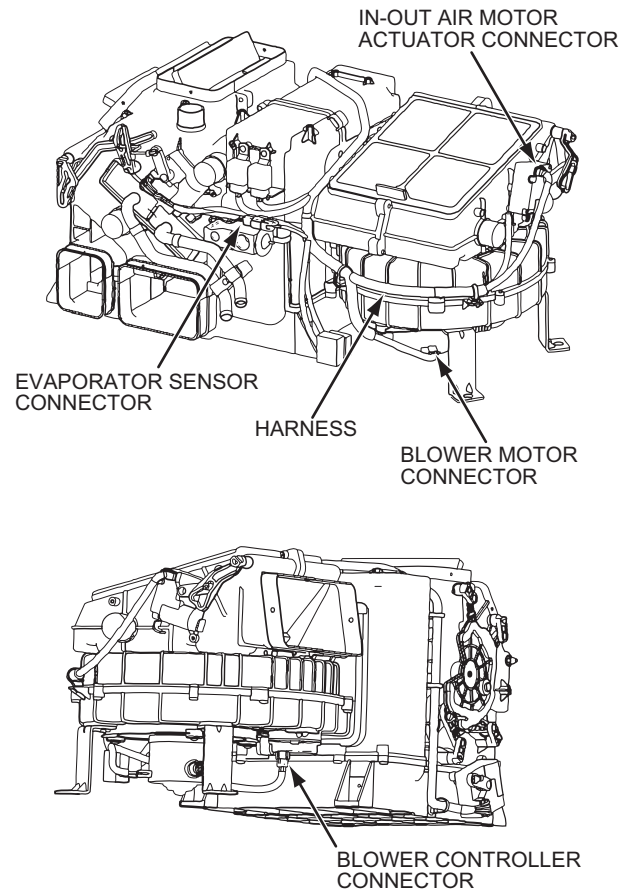

2. Pull out the in air filter from the intake case.
3. Remove four of the cross head screw (Phillips) T5 X 14 (T1) from the intake case.
4. Remove three of the cross head screw (Phillips) T5 X 14 (T1) and separate the blower case and the air-con. unit.

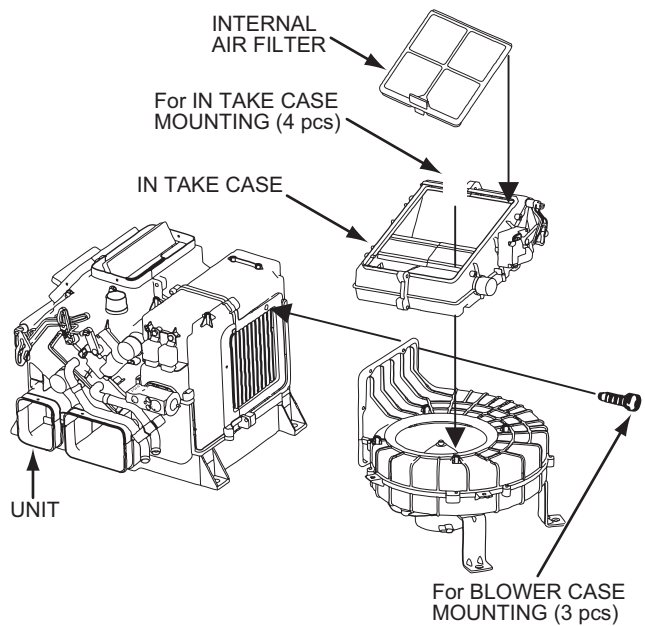

11.3.2 REPLACING THE BLOWER MOTOR

1. Remove the coolant hose coolant between the blower motor and the blower case.
2. Remove three of the cross head screw (Phillips) N5 X 16 (W) which are tightened from under the blower unit case and pull the blower unit out.
3. Take the reverse way in the foregoing procedure for installation.

Do not remove the fan from the blower motor.

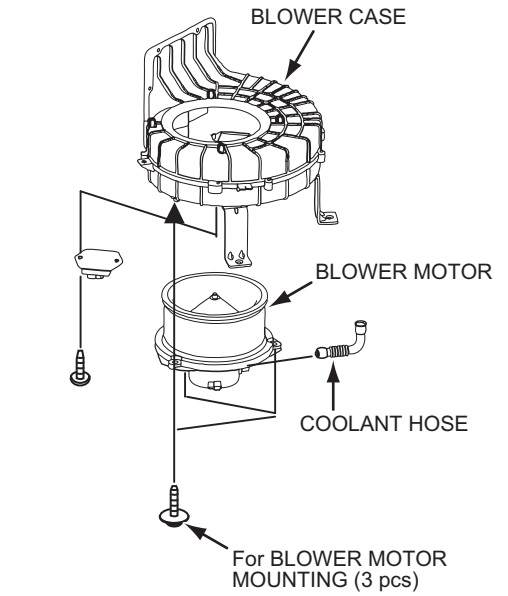

11.3.3 REPLACING THE BLOWER CONTROLLER

1. Remove two of the cross head screw (Phillips) T4 X 14 (T1) which are tightened from under the blower case and pull the blower controller out.
2. Installation of the new blower controller is in the reverse way of the foregoing procedure.

NEVER disassemble the blower controller.

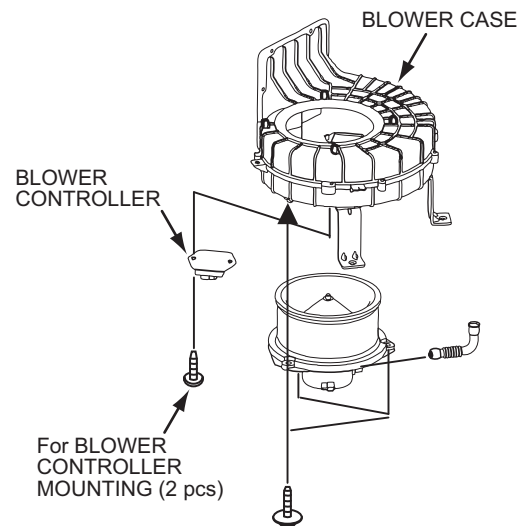

11.3.4 REMOVAL OF THE HEATER CORE

1. Drain out the cooling water.
2. Remove one of the cross head screw (Phillips) N5 X 16 (T2) and pipe clamp which secure the heater core to the unit. Then pull out the heater core from the unit.
3. Installation is reverse way of the foregoing procedure.

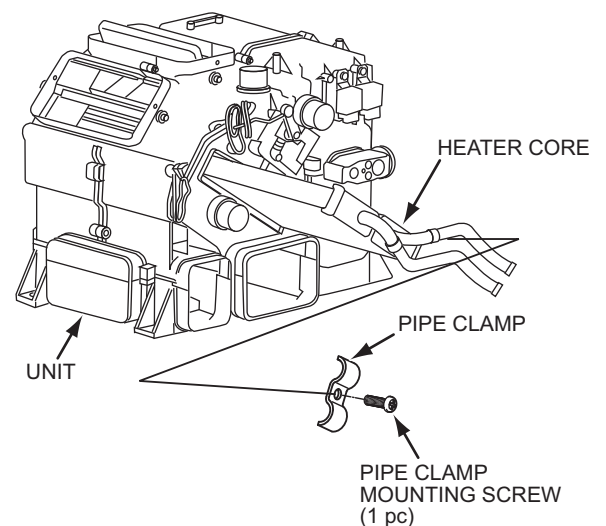

11. AIR CONDITIONER

11.3.5 REMOVAL OF THE AIR-CON UNIT CASE-FRONT AND- REAR

1. Remove the mode motor actuator and the evaporator sensor connector.
2. Remove the mode rod from the rod holder which is installed on the lever MAL1 of the mode motor actuator.
3. Remove three screws N4 X 30 (T1) and remove the mode motor actuator installed on the unit case-lower and the unit case-rear.

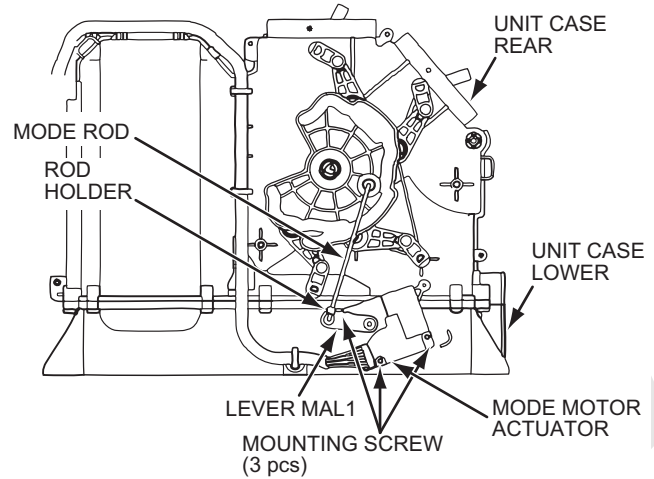

4. Remove eleven of the cross head screw (Phillips) N5 X 16 (T2) and remove the unit case-lower and the unit case-front. Pull the unit case upward taking care of evaporator sensor cord not to catch the case.

In this case make sure that the heater core is removed from the unit case.

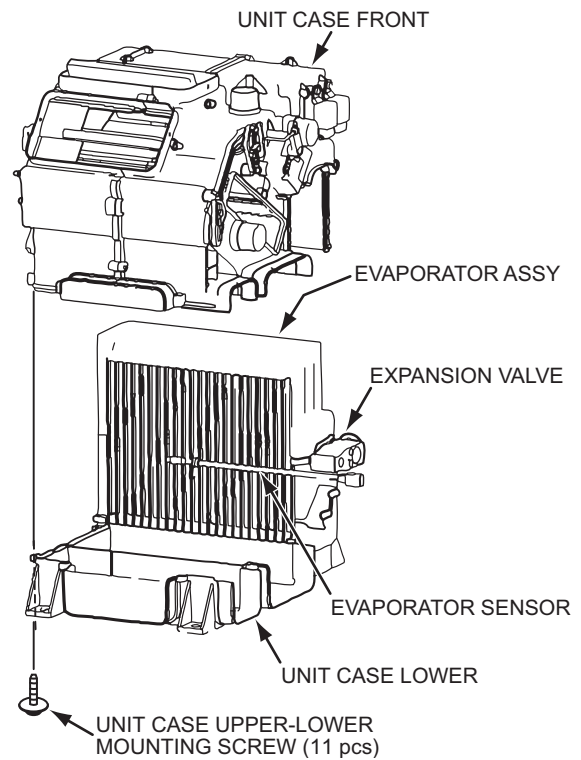

11.3.6 REPLACING THE EVAPORATOR AND EXPANSION VALVE

1. Pull out the evaporator assy from the case-lower with the case insulation material and the expansion valve attached.
2. After the evaporator assy is removed, then pull out the evaporator sensor and sensor holder as one piece.
3. Remove the HEX. socket head screw M5 X 40 (two) and remove the expansion valve from the evaporator with the hex. wrench (4 mm).
4. Install the O-ring (NFO ring 5/8 and 1/2, one each) to the new evaporator.
(Tightening torque 6.9 N-m)

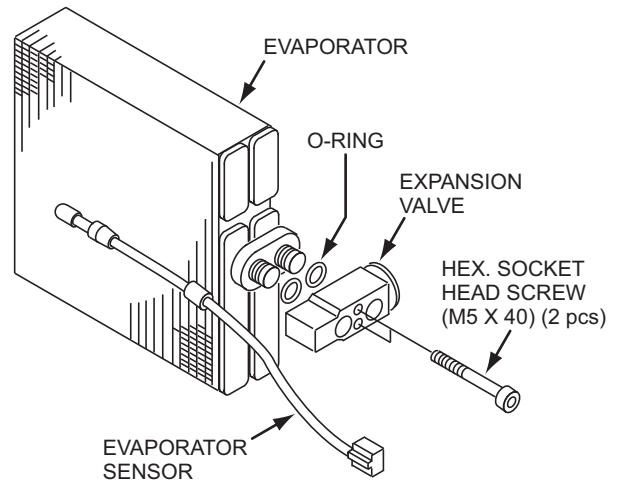

Be careful not to make the O-ring jammed during the expansion valve installation.

11.3.7 INSTALLATION OF EVAPORATOR SENSOR

Install the evaporator sensor precisely to the original place of the evaporator as shown.

During the installation work, take care not to make the sensor cord jammed with the case.

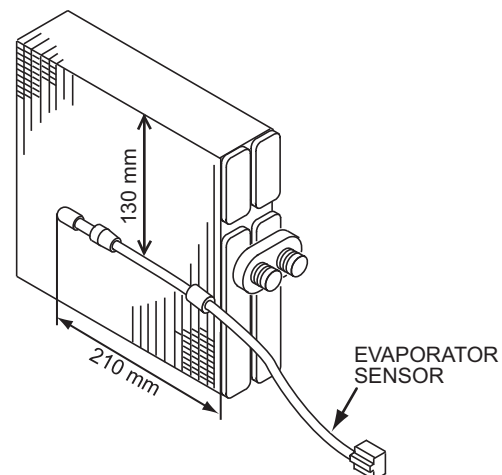

11. AIR CONDITIONER

11.3.8 REPLACING THE MOTOR ACTUATOR

1. REPLACING THE MODE MOTOR ACTUATOR

Remove the connector of the motor actuator.
Remove the mode rod which connects the motor actuator and the mode cam from the rod holder.
Remove three of the cross head screw (Phillips) N4 X 30 (T1) which hold the motor actuator and remove the motor actuator from the unit while the rod holder and lever MAL1 are attached to the motor actuator.
Remove the rod holder and the lever MAL1 from the motor actuator and install the new actuator in the reverse way of this procedure.

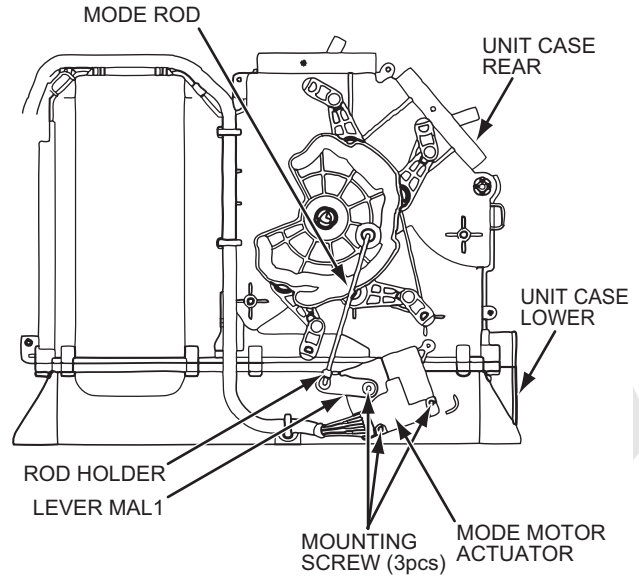

2. REPLACING THE AIR MOTOR ACTUATOR

Remove the connector connected to the motor actuator.
Remove the AM rod which connect the motor actuator and the lever MAL1 from the rod holder.
Remove the three of the cross head screw (Phillips) N4 X 30 (T1) holding the motor actuator.
Remove the motor actuator from the unit while the rod holder and lever MAL1 are attached. Remove the rod holder and lever MAL1 from the motor actuator.
Install the new motor actuator to the unit in the reverse way of the foregoing procedure.

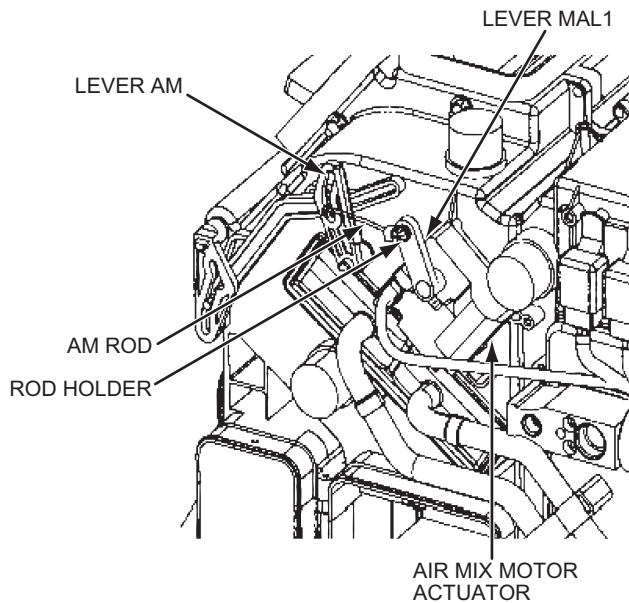

3. REPLACING THE IN-OUT AIR MOTOR ACTUATOR

Remove the connector connected to the motor actuator.
Remove three of the cross head screw (Phillips) N4 X 28 (T1) holding the motor actuator.
Remove the motor actuator from the unit while the lever MAL2 is attached. Remove the lever MAL2 from the motor actuator.
Install the new motor actuator in the reverse way of the foregoing procedure.

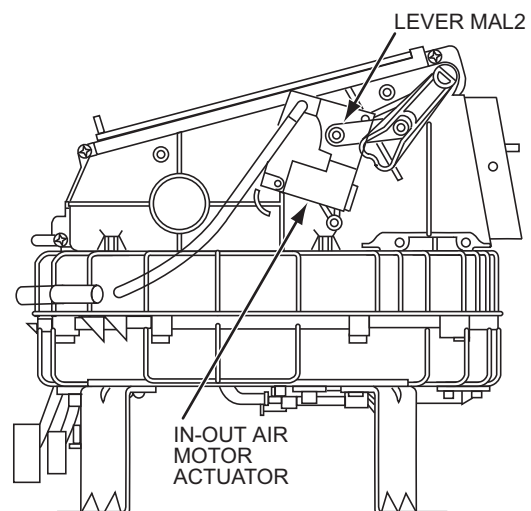

11.4 FAULT DETECTION FROM THE CONTROL PANEL INDICATION

11.4.1 GENERAL

When there is any fault in the input circuit of the controller of the motor actuator drive line or each sensor, fault detection is indicated.

CAUTION

Once the fault is detected, fault detection is not reset even the fault returns to normal.

Turning the vehicle's main key switch is turned to OFF, then the fault is reset.

11.4.2 FAULT IN THE INPUT AND OUTPUT CIRCUIT OF THE MOTOR ACTUATOR

1. OPEN CIRCUIT DETECTION

If there is an open circuit or short circuit in the motor actuator line, open circuit detection is indicated.

OPEN CIRCUIT DETECT INDICATION

FAULT LOCATION	FAULT INDICATION
AIR MIX (TEMPERATURE CONTROL)	HOT MARK BLINKING

2. MOTOR LOCK DETECTION

If the motor speed does not reach the target, LOCK is detected and motor output is ceased and motor lock detection is indicated.

MOTOR LOCK DETECT INDICATION

FAULT LOCATION	FAULT INDICATION
AIR MIX (TEMPERATURE CONTROL)	HOT MARK BLINKING
IN-OUT AIR MOTOR ACTUATOR	IN-OUT AIR MARK BLINKING

11.4.3 FAULT IN THE THERMISTOR SENSOR CIRCUIT

1. OPEN OR SHORT CIRCUIT

Open circuit detect is indicated when there is an open or short circuit in the sensor line.

OPEN CIRCUIT DETECT INDICATION

FAULT LOCATION	FAULT INDICATION
EVAPORATOR SENSOR	AIR CON. MARK BLINKING

11.5 BASIC SYSTEM OF HVAC

This is the built in type air con. unit with evaporator, heater core and blower as one package and generate cool and warm air.

1. AIR CYCLE

- HEATER

The unit takes internal air of the cab or open air from the intake port and have them passed through the air filter and send them to the heater core of the air conditioner unit to exchange heat and send the warm air through the duct and blow out from the grill.

- COOLER

The unit takes internal air of the cab or open air from the intake port and have it passed through the air filter and send them to the evaporator to exchange the heat (dehumidifying cool) and send the cooled air to the duct and blow out the air from the grill.

- HEATER SYSTEM

The heater unit circulates the engine cooling water. The warm water from the engine is sent to the heater core to exchange heat.

Air sucked in is warmed up and is blown out from the grill inside of the cab.

Temperature of the blow air can be adjusted by temperature adjusting switch.

This air movement is controlled by the air mix damper of the air conditioner unit.

2. CONTROL PANEL AND CONTROL UNIT

The control panel and the control unit is one package.

Micro computer inside of the unit handles the arithmetic processing of input signal from each sensor with the input signal of each switch in the control panel and totally controls the fan motor and compressor and each actuator in the output side of the actuator (in-out blow port selector, air mix).

The unit also has self diagnose function and can perform self diagnose easily.

(For detail refer to the control specification)

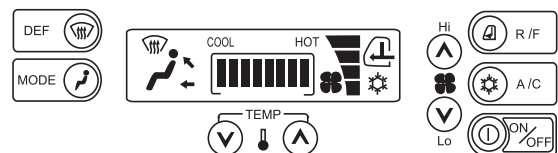

3. FAN DRIVER

The fan driver receives the control signal from the control unit and control the fan motor speed.

NORMAL CONDITION

	TERMINAL NO.			CONTINUITY
	1	2	3	
TESTER	+		-	YES (4.7 kΩ ± 5%)
	-	+		NO
	+	-		YES (DIODE PARALLEL FORWARD DIRECTION)

- (1) Remove the connector of the blower amplifier.
- (2) Check the continuity between each terminal of the blower amplifier.

- The amplifier is located in the left hand of the air conditioner unit.

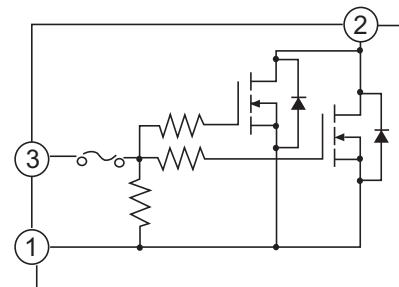
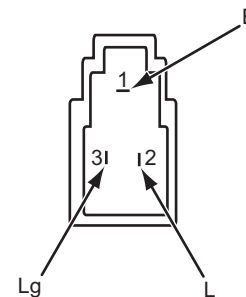
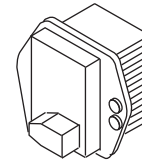

4. RELAY

The blower OFF relay and the compressor relay are four pole relay.

5. BLOWER OFF RELAY

The blower OFF relay turns ON when the signal from the control amplifier is received. When the blower OFF relay turns ON, power is supplied to the blower motor and the blower motor starts.

6. COMPRESSOR RELAY

This relay turns ON-OFF by the compressor control of the control amplifier.

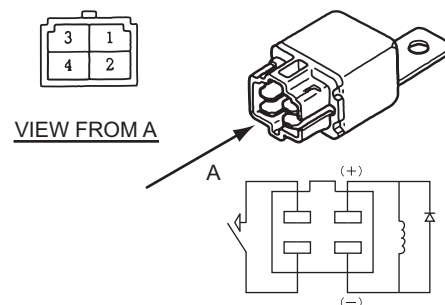

11. AIR CONDITIONER

7. INSPECTION POINTS OF THE RELAY

- (1) RELAY
- (2) COIL RESISTANCE : 320Ω
- (3) VOLTAGE : DC20 V to 30 V
- (4) Note : This relay has coil polarity.
- (5) Inspection : Check the continuity between the terminal 3 to 4 under the following condition.

Apply 20 to 30 V between the terminal 1 and 2 : Continuity should be YES

Apply no voltage between the terminal 1 and 2 : Continuity should be NO

8. AIR MIX ACTUATOR

The air mix actuator is installed in the center of the air conditioner unit and controls OPEN/CLOSE of the air mix damper.

The air mix actuator has the potentiometer in its inside to be controller by the actuator shaft movement.

When the target position of the air mix door is decided by the temperature control switch, the control system reads the potentiometer indication of the actuator and decides the direction of motor rotation.

The contact moves together with the motor and comes to separate its contact point or reaches to the target position of the potentiometer indication to make output signal OFF from the control unit. Then the motor stops.

(Refer to the inspection of the air mix motor actuator.)

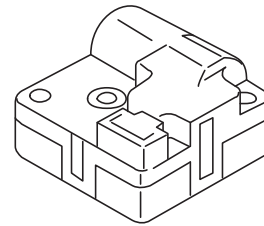

9. IN-OUT AIR ACTUATOR

In-out air actuator is installed in the blower intake unit and opens or closes the in-out air damper through the linkage.

In-out air actuator has the position detect switch in its inside which is controlled by the shaft movement of the actuator.

When the target location of the in-out air damper is decided by the in-out air selector switch of the control unit, the control system reads the potentiometer indication of the actuator and decides the direction of motor rotation.

The contact moves together with motor and stops the motor by reaching to the target position.

(Refer to inspection of the In-out motor actuator.)

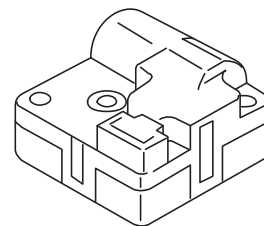

10. BLOW OUT MODE ACTUATOR

The blow out mode actuator is installed in the back side of the air conditioner unit and opens or closes the blow out damper through the linkage.

The bow out mode actuator has the potentiometer in its inside which is controlled by the shaft movement of the actuator.

When the target position of the blow out mode is decided by the temperature control switch, the control system reads the potentiometer indication of the actuator and decides the direction of motor rotation.

The contact moves together with the motor and comes to separate its contact point or reaches to the target position of the potentiometer indication to make output signal OFF from the control unit. Then the motor stops.

(Refer to the inspection of the motor actuator.)

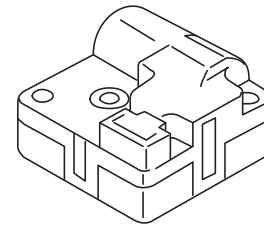

11. EVAPORATOR SENSOR

This sensor controls ON-OFF of the compressor by detecting the temperature of the bow out air of the evaporator to prevent it from freezing.

- INSPECTION OF THE EVAPORATOR
(Specification data)

Remove the evaporator sensor connector from the main harness and measure the resistance value between the terminals to the sensor with the multi-tester.

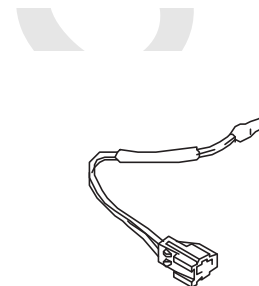

Resistance value between terminal to the sensor	When the sensor detect temp. is 0° C : 7.2 kΩ
	When the sensor detect temp. is 25° C : 2.2 kΩ

11. AIR CONDITIONER

12. DUAL PRESSURE SWITCH

The dual pressure switch is installed in the receiver dryer and protect the cooling cycle by opening its contact and cutting the power supply to the compressor when the high pressure side of cooling becomes malfunction (high pressure faulty, low pressure faulty).

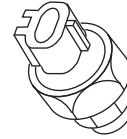

• SIMPLE INSPECTION OF DUAL PRESSURE SWITCH

- (1) Disconnect the connector from the switch when the cooling cycle is stopped and check the continuity between the terminal to the switch and to the connector with the multi-tester.

If the continuity is YES, then it is normal.

(When the ambient temperature is above 0° C)

- (2) Connect the high pressure side hose of the gauge manifold to the high pressure side charge port and raise the high side pressure when the cooling cycle is operating. Cover the front face of the condenser with some board or such during this work.

If the compressor stops at 3.14 MPa or around then the system is normal.

- (3) Check the continuity between the terminal to the switch and to the connector when the coolant is removed.

If continuity is NO, the system is normal.

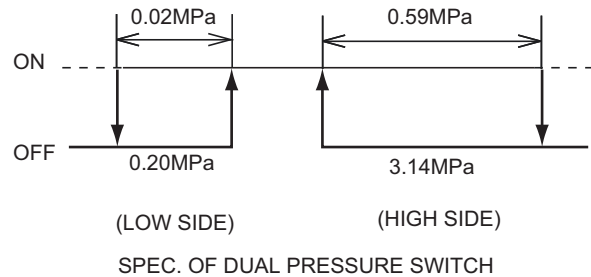

11.6 RECHARGING OF THE COOLANT

11.6.1 CAUTION AT WORK

1. Make sure that the work is done by the specialist.
Recharging work consist of high pressure gas handling. Make sure that the work is done with the specialist who is familiar with the work.

CAUTION

- Make sure to wear a SAFETY GLASS.
(If the coolant material gets into eye, it may cause the loss of eyesight.)
 - The coolant in its liquid form is EXTREMELY LOW temperature (approx. 26° C below zero).
Handle it with extra care.
(If they touch the skin, it may cause the frostbite.)
-

2. STORAGE AND TRANSPORT

- (1) Store the service bottle (Hereafter called bottle) in the temperature below 40° C.
High pressure gas "R134a" is contained inside the bottle in the saturated liquid form. Rapid rise of the temperature may cause burst of the bottle and is very dangerous.
Therefore it is NECESSARY to store the bottle in the cold place under minus 40° C temperature.
- (2) Prevent direct sunlight to the bottle and store them in the cool and dark place.
- (3) If the bottle is placed close to the fire, it may raise the temperature due to the heat radiation and may cause to raise the inside pressure and virtually may cause burst of the bottle. Never place the bottle close to the fire.
- (4) Temperature on the closed operator's room will be risen quickly to the dangerous range even at the winter time when the radiant heat from the sun strikes it.
Do not take the bottle into the closed operator's room even at the winder time.
Temperature in the storage box also rises to dangerous range at summer time. Be careful on this point.

11. AIR CONDITIONER

- (5) Flaw, indent mark or deformation may decrease the strength of the bottle. Be careful on this point.
- (A) Do not drop or hit the bottle.
- (B) Take care in loading, transporting and unloading the bottles or packing case containing the bottles. Handle with care and do not drop or throw them.
- (6) Do not store the bottle within the reach of the children.

3. AT THE RECHARGING TIME

- (1) When the bottle is to be warmed up for recharging, make sure to open the bottle valve , the low pressure side gauge manifold and then warm up the bottle with warm water of about 40° C temperature (Below hand hot temperature!). Do not put the bottle into the hot water or heat up with direct fire. Otherwise the pressure may go up quickly and may burst the bottle.
- (2) When the engine is started to recharge the bottle with the coolant, NEVER open the high pressure valve (HI) of the gauge manifold. Opening the high pressure valve may cause the high pressure gas to backflow and may cause to burst the bottle or the charging hose and is very dangerous.

4. OTHERS

Reuse of the recharge bottle is prohibited by law. NEVER reuse.
Do not put any foreign material into the air conditioner piping.
Cooling cycle hates air, water and dust.
Assembling work of the air conditioner must be done quickly and take extra care to prevent water, dust entering into the system.



Pay attention not to overcharge.

Tighten all the pipe fittings with the specified torque.

11.6.2 WORK PROCEDURE

1. Recharging work of the coolant into the air conditioner is divided into "Vacuuming work" and "Gas recharging work".

(1) "Vacuuming work" is to delete the water in the air conditioner piping completely.

Even a slight amount of water is left in the piping, it will be frozen in the small holes in the expansion valve during the operation and may cause piping clogged or rust inside the piping or other trouble. In order to avoid these troubles the vacuuming work must be done to boil off the water in the piping prior to recharge the coolant into the piping.

(2) "Gas recharging work" is to recharge the system with the coolant after the vacuuming work is completed.

Gas recharging work is the main work and affects not only the cooling performance of the air conditioner but also to the life of the circuit. Extreme over charging may cause abnormal high pressure in the system and may lower the cooling performance.

On the other hand, extreme low amount of the coolant may cause poor circulation of the lubricant to the air compressor and may virtually cause seizure on the sliding area.

Gas recharging work also handle the high pressure gas and wrong handling is very dangerous.





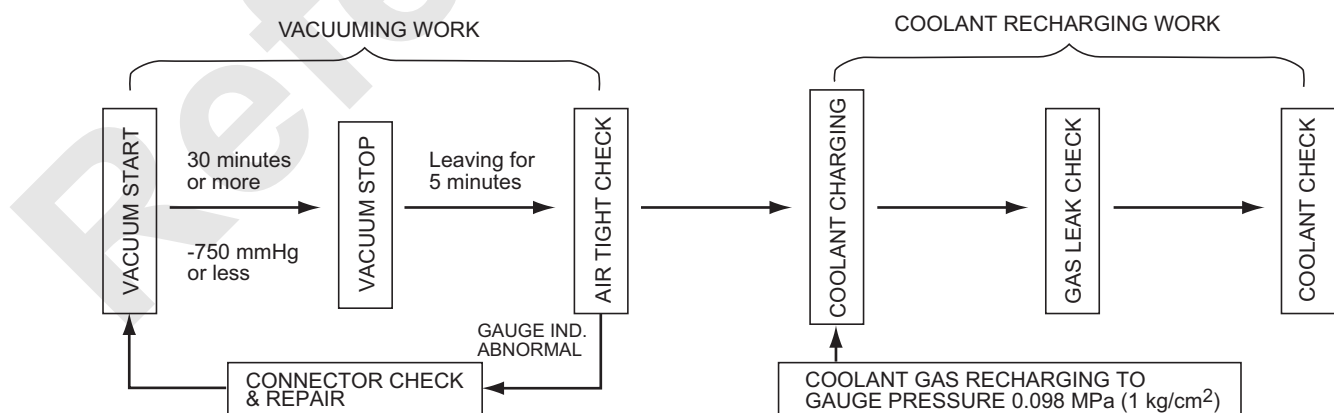

Carry out the coolant recharging by exactly following the procedure mentioned in this manual.

2. WORK CHART

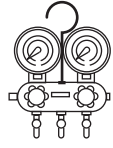

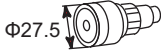
11. AIR CONDITIONER

3. TOOL

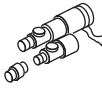
No.	NAME	QUANTITY	SHAPE	USE
1	GAUGE MANIFOLD	1		
2	CHARGING HOSE	3		RED : HIGH PRESSURE SIDE BLUE : LOW PRESSURE SIDE YELLOW : VACUUM PUMP SIDE
3	QUICK JOINT	1		
4	QUICK JOINT	1		LOW PRESSURE SIDE
5	T-JOINT	1		SERVICE BOTTLE VALVE
6	SERVICE BOTTLE VALVE	2		FOR SERVICE BOTTLE
7	VACUUM PUMP ADAPTER	1		FOR VACUUM PUMP

11.6.3 RECHARGING PROCEDURE

VACUUMING WORK

1. CONNECTION OF GAUGE MANIFOLD

- (1) Close the high pressure valve (HI) and low pressure valve (LO) of the gauge manifold.
- (2) Connect the charging hose (Red and Blue) to the service valve of the compressor.

Red hose :

High pressure side of the gauge manifold → (HI)
 High pressure side of the compressor (DIS)

Blue hose :

Low pressure side of gauge manifold (LO) →
 Low pressure side of the compressor (SUC)

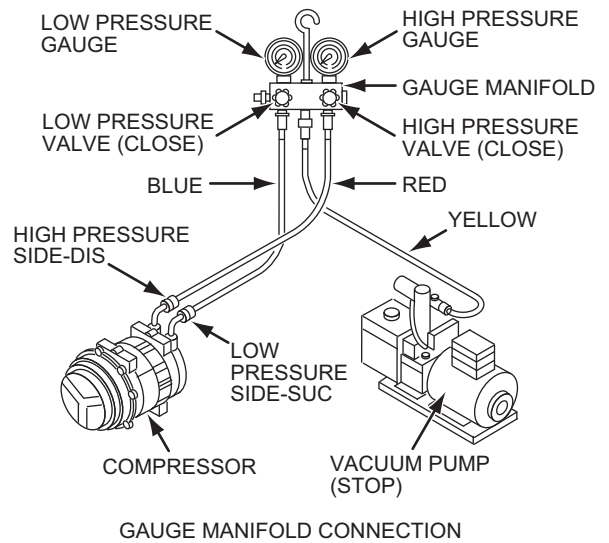

CAUTION

- Do not mix the high pressure side and low pressure side connection.
 Push the hose firmly until "the click" sounds.
- Connect the charging hose with "L" shaped end to the service valve of the compressor.
 The "L" shaped end has a check valve. If connected in reverse way, check valve of the compressor will not open.

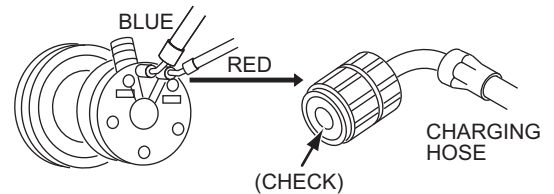

COMPRESSOR PIPING CONNECTION

- (3) Connect the center valve of the gauge manifold and the vacuum pump with the charging hose.

CAUTION

Some type of the gauge manifold does not have the open/close valve in their center.

11. AIR CONDITIONER

2. VACUUMING

- (1) Open the high pressure valve (HI) and low pressure valve (LO) of the gauge manifold.
- (2) Turn ON the switch of the vacuum pump and continue vacuuming work for more that 30 minutes.
- (3) When the vacuuming for the specified time is completed (Target figure of vacuum : -750 mgHg or lower), close the high pressure valve and the lower pressure valve.
- (4) Then turn off the switch of the vacuum pump.

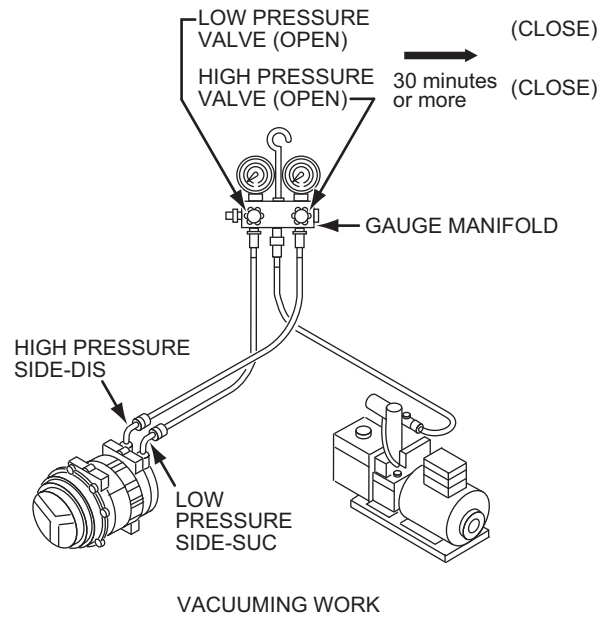

3. AIRTIGHT CHECK

Watch the gauge for more than five minutes while the high pressure valve and the lower pressure valve are closed and confirm that the gauge needle does not move back toward zero direction.

CAUTION

If the gauge moves back toward zero direction, there must be leaking point somewhere. Retighten all of pipe fittings and again repeat the vacuuming work and check for leak again.

GAS RECHARGING WORK

1. RECHARGE FROM THE HIGH PRESSURE SIDE

(1) Disconnect the charging hose (yellow) of the gauge manifold from the vacuum pump and reconnect it to the service bottle after the vacuum pump is completed.

(2) AIR PURGE

Open the service bottle valve. (High pressure side and low pressure side valves must be closed.) Then push the check valve in the service port of the lower pressure side on the gauge manifold with a screw driver or such to purge the air in the charging hose by the coolant pressure. (If the air sound "shoo!" comes out, it is completed.)

(3) Open the high pressure valve of the gauge manifold and charge the coolant. (Charge the coolant gas to 0.098 MPa {1 kgf/cm²} in gauge reading.) After charging close the high pressure valve in the gauge manifold and the service bottle valve.

CAUTION

Never run the compressor. (The coolant will flow back and the service bottle or the hose may burst and is very dangerous.)

2. GAS LEAKING CHECK

Check gas leak in the cooling cycle with the gas leak tester (electric type). If there is any leaking point, re-tighten.

CAUTION

Make sure that the tester is for R134a coolant. (Tester for flon coolant is not usable due to low sensibility)

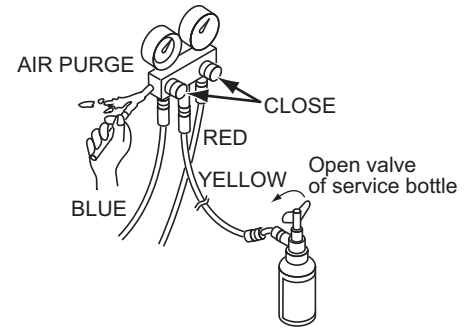

GAS CHARGING WORK

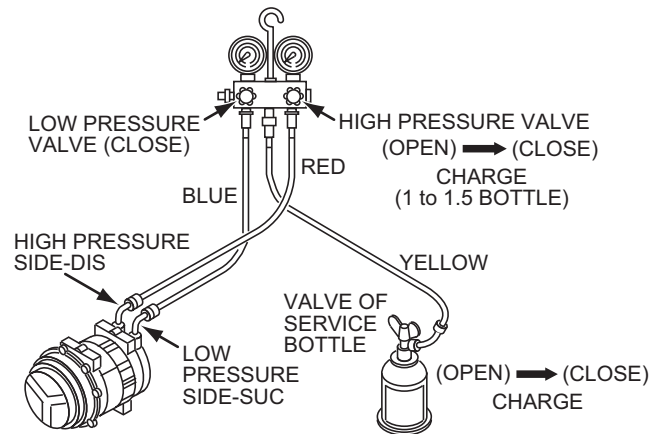

GAS CHARGING WORK (HIGH PRESSURE SIDE)

11. AIR CONDITIONER

3. CHARGING FROM THE LOW PRESSURE SIDE

- (1) Make sure that the valves for high pressure side, low pressure side and service bottle are all closed.
- (2) Start the engine and set the speed to 1400 to 1600 rpm and open the cab door completely.
- (3) Turn ON the air con. switch and set the fan switch to max. and temperature adjusting switch to max. cooling.
- (4) Set the delivery pressure of the compressor to 1.37 to 1.57 MPa {14 to 16 kg/cm²} during charging.

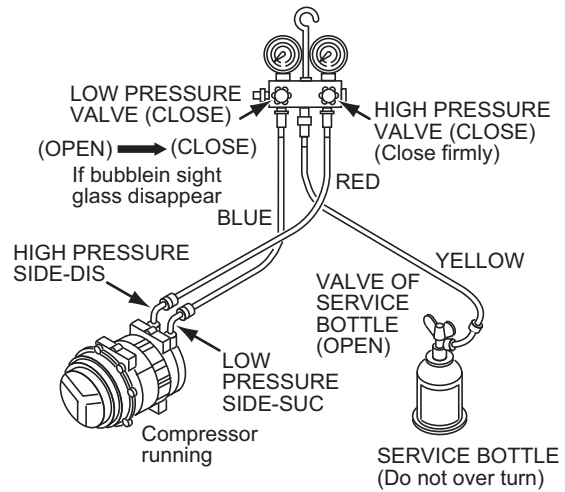

GAS CHARGING WORK (LOW PRESSURE SIDE)

- (5) Open the low pressure valve of the gauge manifold and the service bottle valve and charge the coolant until the bubble in the receiver side glass disappear. (Full gas charging amount : 850 to 950 g)
- (6) When the coolant charging is completed, close the low pressure valve of the manifold and the service bottle valve and stop the engine.

CAUTION

- NEVER open the high pressure side valve of the gauge manifold.
- NEVER place the service bottle upside down. (Liquid form of coolant may be injected into the cooling cycle and may damage the compressor valve.)

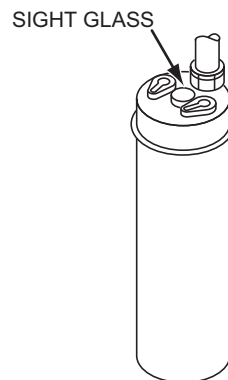



RECEIVER DRYER

4. GUIDEPOST OF RECHARGING COOLANT AMOUNT

- JUDGEMENT FROM SIGHT GLASS VIEW OF THE RECEIVER DRYER

JUDGEMENT FROM SIGHT GLASS VIEW OF THE RECEIVER DRYER

IN CASE OF PROPER CHARGE	After A/C turned on, bubbles appear a little, hereafter it becomes transparent, and shows milk-white.	
IN CASE OF OVERCHARGE	After A/C turned on, no bubble appears.	
IN CASE OF INSUFFICIENT CHARGE	After A/C turned on, bubbles can be seen continuously.	

(Explanation for illustration of refrigerant flowing condition)



Bubbles exist : Vapor and liquid of refrigerant are mixed.



No bubbles : All refrigerant becomes liquid and is transparent.



Impurity : Oil and refrigerant are separated, and show milk-white.

CAUTION

- The air conditioner is operated when the coolant (R134a) is very low, it may badly affect the compressor.
- If the coolant is overcharged, it will rather reduce the cooling performance and the cooling cycle becomes extreme high pressure and is dangerous. Keep the correct amount of coolant.

5. REMOVAL OF THE GAUGE MANIFOLD

When the inspection of coolant recharging is completed, remove the charging hose from the compressor under the following procedure.

- Push the L shaped fitting of the lower pressure side charging hose (blue) to the service valve of the compressor to prevent coolant leaking and loosen the nut.

When the nut is removed, quickly remove the charging hose from the service valve.

- Keep the high pressure side until the high pressure gauge reading becomes lower than 0.98 MPa {10 kg/cm²}.
- Remove the high pressure side charging hose (red) in the same procedure as the low pressure side.

This page is blank for editing convenience.

11.7 ELECTRIC WIRING DIAGRAM

① JAE IL-AG5-22S-D3C1



② JAE IL-AG5-14S-D3C1

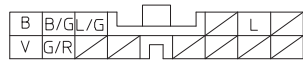

③ YAZAKI 7123-2249



④ YAZAKI 7123-2228



⑤ YAZAKI 7123-2237



⑥ YAZAKI 7123-2228



⑦ YAZAKI 7122-8307

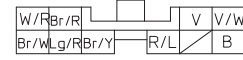

⑧ YAZAKI 7122-8385

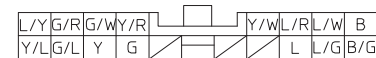

⑨ JAE IL-AG5-7S-S3C1

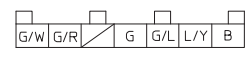

⑩ JAE IL-AG5-7S-S3C1

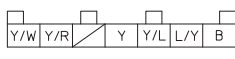

⑪ JAE IL-AG5-7S-S3C1

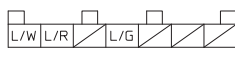

⑫ SUMITOMO 6189-0094



⑬



⑭ YAZAKI 7123-2249



⑮



⑯



Published 09-24-13, Control #209-03

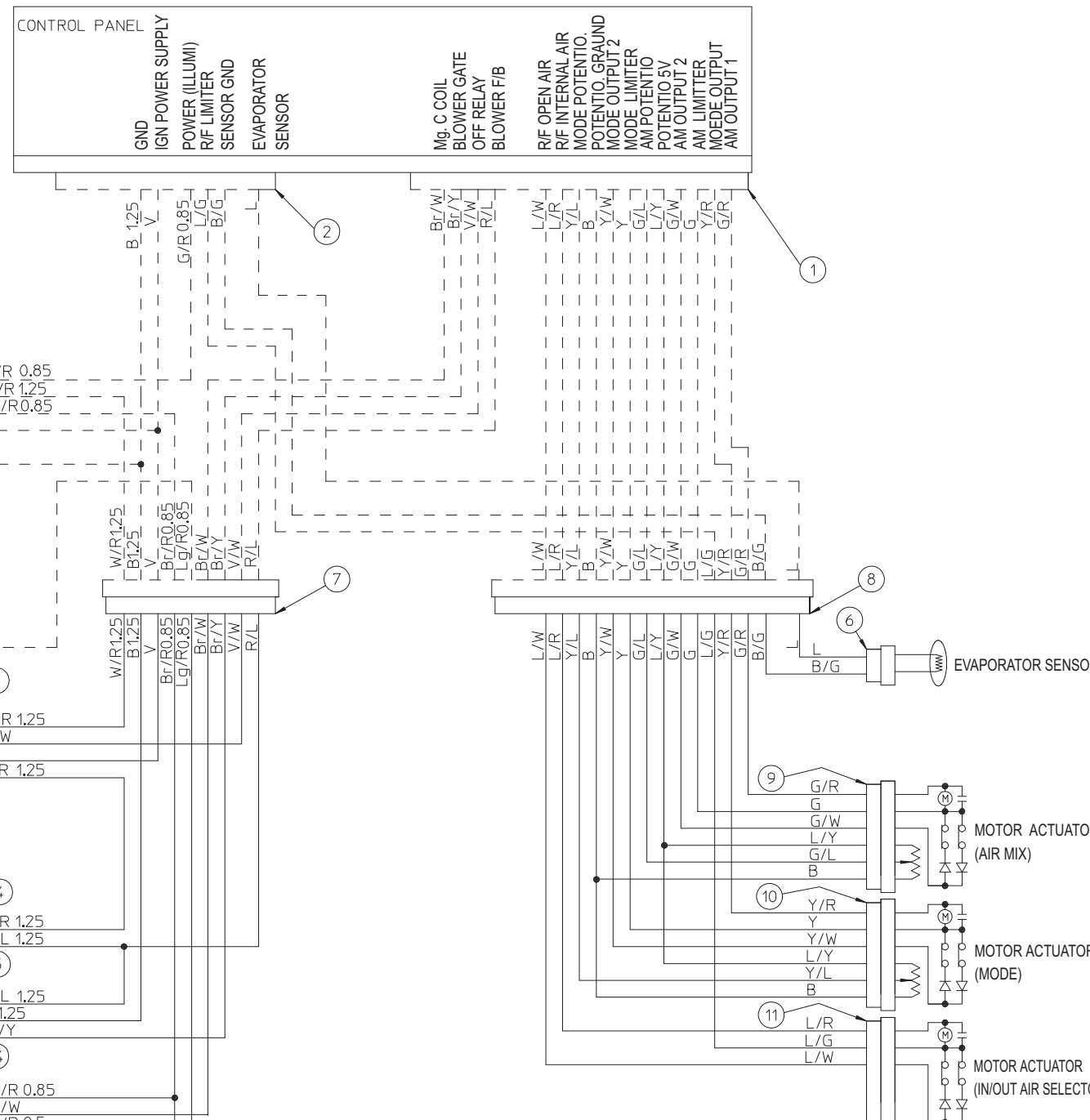

P	W	B	R	Y	G	L	Br	Lg	O	V
PINK	WHITE	BLACK	RED	YELLOW	GREEN	BLUE	BROWN	LIGHT GREEN	ORANGE	VIOLET

1. Wire meter is 0.5 mm unless otherwise specified.
2. Dotted line (.....) is vehicle's body wiring.
3. Connector pin layout color is a view on the mating face.

Reference Only

This page is blank for editing convenience.

12. TROUBLESHOOTING

Reference Only

Reference Only

12.1 TROUBLESHOOTING

What actions should be taken upon occurrence of these problems ?

Portion in question	Symptom	Possible cause	Check points	Remedy
Engine	Engine does not start.	Battery is dead. Starter is not rotating.	Check the battery electrolyte for level and specific gravity.	Charge or replace the battery.
			Check the starter relay for operation.	Replace the starter relay.
			Check contents of the error warning displayed on the main monitor.	Reset the error warning.
			Check that the Engine Emergency Stop switch is not pushed.	Release the Engine Emergency Stop switch (inside cabin or via remote controller).
			Check the safety relay for operation.	Replace the safety relay.
			The operator is not authenticated.	Conduct operator authentication work.
			Check whether the fuse (F30) is blown or not.	Replace the fuse (F30).
			Check presence of fuel and flow of fuel in piping.	Supply fuel or replenish fuel in the priming pump.
			Check elements of the fuel filters (main and pre filters) for clogging.	Conduct air bleeding.
			Check that fuel open/close valve is not closed.	Replace elements of the fuel filters (main and pre filters)
			Check that air cleaner element is not clogged.	Open the open/close valve.
			Check the air intake piping (from air cleaner, turbo intercooler to engine) for clogging.	Clean or replace the air cleaner element.
			Check contents of the error.	Eliminate the clogging.
			Engine error signal (P code) is output.	Take action after locating the cause in accordance with the Engine Maintenance Manual. Inform Hino Motors, Ltd. as needed.
Engine does not stop.	Defective electrical system	Replace the key switch.		
Engine speed does not increase.	Accelerator grip is in trouble.	Flip the aux. accelerator switch toward "ON" side.		

12. TROUBLESHOOTING

Portion in question	Symptom	Possible cause	Check points	Remedy
Engine	Engine speed does not increase.	Malfunctioning of ECU	Check the P code.	Check the Engine Manual.
		Defective electrical system	Defective controller	Replace the controller. (Conduct the work with aux. accelerator.)
		Engine error signal (P code) is output.	Check contents of the error.	Take action after locating the cause in accordance with the Engine Maintenance Manual. Inform Hino Motors, Ltd. as needed.
		Fuel is not supplied.	Check presence of fuel and flow of fuel in piping.	Supply fuel or replenish fuel in the priming pump.
			Check elements of the fuel filters (main and pre filters) for clogging.	Conduct air bleeding. Replace elements of the fuel filters (main and pre filters)
			Check that air cleaner element is not clogged.	Clean or replace the air cleaner element.
			Check the air intake piping (from air cleaner, turbo intercooler to engine) for clogging.	Eliminate the clogging.
			Check contents of the error.	Take action after locating the cause in accordance with the Engine Maintenance Manual. Inform Hino Motors, Ltd. as needed.
			Check the cooling water level.	Replenish cooling water.
		Engine	Overheating	Cooling water is short.
Cooling water is not supplied.	Check water piping for clogging.			Eliminate the clogging.
Cold wind is not flowing.	Check that the fan is not slipping.			Adjust the V belt tension.
	Check that the radiator front face is not blocked with dust and others.			Blow air to clean the radiator.
Check that there are no obstacles in openings on the air supply and exhaust sides of the guard.	Remove the obstacles.			
Engine error signal (P code) is output.	Check contents of the error.			Take action after locating the cause in accordance with the Engine Maintenance Manual. Inform Hino Motors, Ltd. as needed.

Portion in question	Symptom	Possible cause	Check points	Remedy
Winch system	Hoisting and lowering impracticable	Hydraulic oil is short.	Check the hydraulic oil tank oil level.	Replenish hydraulic oil.
		Clutch operation is slippery.	Check the suction strainer for clogging.	Wash or replace the strainer.
		Malfunctioning of remote control valve	Check the positive and negative pressures.	Replace the positive and negative pressure selector valve.
			Check whether the secondary pressure generation condition is normal.	Replace the remote control valve.
			Check the primary pressure.	Regulate the primary pressure or replace the valve.
		Malfunctioning of remote control circuit relief valve	Check the function lock limit switch for operation.	Regulate operation of the limit switch or replace the limit switch.
			Check the function lock solenoid valve for operation.	Regulate operation of the solenoid valve or replace the solenoid valve.
		Malfunctioning of main pump	Check whether propelling of the system is possible.	Replace the main pump.
		Malfunctioning of main valve	Check the main valve relief pressure.	Regulate the relief valve pressure or replace the relief valve.
			Check the pilot pressure on the main valve.	Look into and replace the remote control valve.
			Check the counter balance valve spool for operation.	Replace the spool or replace the valve.
		Malfunctioning of hoisting motor	Check the counter balance valve poppet for deposition of contaminant and flaw on seat surface.	Wash or replace the poppet.
		Malfunctioning of hoisting reduction gears	Check the motor drain oil level.	Replace the motor.
		Automatic stop and electrical stop of interlock and others	Check the system for unusual noise, abnormally high temperature and vibrations.	Replace the reduction gears.
	Check the contents of the functional operations.	Release the functions (elimination of cause of auto stop and release of interlock)		

12. TROUBLESHOOTING

Portion in question	Symptom	Possible cause	Check points	Remedy	
Winch system	Intended hoisting and lowering speeds cannot be attained.	Hydraulic oil is short.	Check the hydraulic oil tank oil level.	Replenish hydraulic oil.	
			Clutch operation is slippery.	Check the suction strainer for clogging.	Wash or replace the strainer.
				Check the positive and negative pressures.	Replace the positive and negative pressure selector valve.
				Check whether the secondary pressure generation condition is normal.	Replace the remote control valve.
		Malfunctioning of remote control valve relief valve	Check the primary pressure.	Regulate the primary pressure or replace the valve.	
			Malfunctioning of main pump	Check whether propelling of the system is possible.	Replace the main pump.
		Malfunctioning of main valve	Check the main valve relief pressure.	Regulate the relief valve pressure or replace the relief valve.	
			Check the pilot pressure on the main valve.	Look into and replace the remote control valve.	
		Malfunctioning of hoisting motor	Check the counter balance valve spool for operation.	Replace the spool or replace the valve.	
			Check the counter balance valve poppet for deposition of contaminant and flaw on seat surface.	Wash or replace the poppet.	
			Check the motor drain oil level.	Replace the motor.	
			Look into motor tilted rotation control solenoid proportional valve.	Replace the solenoid proportional pressure reducing valve.	
			Check the system for unusual noise, abnormally high temperature and vibrations.	Replace the reduction gears.	
			Check the voltage of the engine rotation grip or rotating speed sensor.	Adjust the rotation grip L/H level or replace the rotation grip.	
Malfunctioning of engine sensing	Check the voltage of the main pump solenoid proportional pressure reducing valve.	Adjust or replace the solenoid proportional pressure reducing valve.			
	Speed trimmer is minimized.	Check the speed trimmer level.	Maximize the speed trimmer.		

Portion in question	Symptom	Possible cause	Check points	Remedy		
Winch system	Hoisting and lowering speeds cannot be controlled.	Clutch operation is slippery.	Check the positive and negative pressures.	Replace the positive and negative pressure selector valve.		
		Malfunctioning of remote control valve	Check whether the secondary pressure generation condition is normal.	Replace the remote control valve.		
		Malfunctioning of remote control circuit relief valve	Check whether the primary pressure generation condition is normal.	Regulate the primary pressure or replace the valve.		
		Malfunctioning of main pump	Check whether propelling of the system is possible.	Replace the main pump.		
		Malfunctioning of main valve	Check the main valve relief pressure.	Regulate the relief valve pressure or replace the relief valve.		
		Malfunctioning of hoisting motor	Check the pilot pressure on the main valve.	Look into and replace the remote control valve.		
		Malfunctioning of hoisting reduction gears	Check the counter balance valve spool for operation.	Replace the spool or replace the valve.		
		Clutch operation is slippery.	Check the motor drain oil level.	Replace the motor.		
		Malfunctioning of remote control valve	Check the system for unusual noise, abnormally high temperature and vibrations.	Replace the reduction gears.		
		Malfunctioning of remote control circuit relief valve	Check the positive and negative pressures.	Replace the positive and negative pressure selector valve.		
		Slow working of negative brake valve	Check whether the secondary pressure generation condition is normal.	Replace the remote control valve.		
		Load picked and carried cannot be held.		Malfunctioning of remote control valve	Check whether the primary pressure generation condition is normal.	Regulate the primary pressure or replace the valve.
				Malfunctioning of hoisting motor	Look into the negative brake release pressure.	Look into the negative brake release valve and the slow return valve.
					Check the counter balance valve spool for operation.	Replace the spool or replace the valve.
			Check the counter balance valve poppet for deposition of contaminant and flaw on seat surface.	Wash or replace the poppet.		
			Check the motor drain oil level.	Replace the motor.		

12. TROUBLESHOOTING

Portion in question	Symptom	Possible cause	Check points	Remedy	
Winch system	Load picked and carried cannot be held.		[Operations on negative brake side]		
			Clutch operation is slippery.	Check the positive and negative pressures.	Replace the positive and negative pressure selector valve.
			Negative brake is released.	Look into the negative brake release pressure.	Look into the negative brake release valve and the slow return valve.
			Malfunctioning of remote control valve	Look into the secondary pressure.	Replace the remote control valve.
	Free fall is unavailable.		[Operations on positive brake side]		
			Clutch operation is slippery.	Check the brake pedal linkage for loosening and interference.	Adjust or repair the linkage.
				Check the positive and negative pressures.	Replace the positive and negative pressure selector valve.
				Check the positive and negative pressures.	Replace the positive and negative pressure selector valve.
				Check the brake pedal linkage for loosening and interference.	Adjust or repair the linkage.
				Clutch cannot be released.	Replace the negative and positive brake units.
					Replace the spool or replace the valve.
				Malfunctioning of remote control circuit relief valve	Regulate the primary pressure or replace the valve.
					Regulate operation of the limit switch or replace the limit switch.
Malfunctioning of hoisting reduction gears			Regulate operation of the solenoid valve or replace the solenoid valve.		
			Check the shaft and bearing for unusual noise and seizure.		
			Repair the shaft and bearing or replace parts.		
			Replace the fuse (F-38) or repair the wiring.		
Defective electrical system			Replace the switch or repair the wiring.		
			Check the relay for switching and the contact for burn mark.		
			Replace the relay or repair the wiring.		
		Check the free fall selector solenoid valve for operation.	Replace the solenoid valve or repair the wiring.		

Portion in question	Symptom	Possible cause	Check points	Remedy	
Winch system	Hunting	Hydraulic oil is short.	Check the hydraulic oil tank oil level.	Replenish hydraulic oil.	
			Check the suction strainer for clogging.	Wash or replace the strainer.	
		Malfunctioning of hoisting motor	Check the counter balance valve spool for operation.	Replace the spool or replace the valve.	
			Check the counter balance valve poppet for deposition of contaminant and flaw on seat surface.	Wash or replace the poppet.	
			Check the motor drain oil level.	Replace the motor.	
			Check whether the secondary pressure generation condition is normal.	Replace the spool or replace the valve.	
			Check the primary pressure.	Regulate the primary pressure or replace the valve.	
			Check the function lock limit switch for operation.	Regulate operation of the limit switch or replace the limit switch.	
		Malfunctioning of remote control valve relief valve	Check the function lock solenoid valve for operation.	Regulate operation of the solenoid valve or replace the solenoid valve.	
			Check the main valve relief pressure.	Regulate the relief valve pressure or replace the relief valve.	
			Check the pilot pressure on the main valve.	Look into the remote control valve.	
			Check the counter balance valve spool for operation.	Replace the spool or replace the valve.	
		Malfunctioning of main valve	Malfunctioning of hoisting motor	Check the counter balance valve poppet for deposition of contaminant and flaw on seat surface.	Wash or replace the poppet.
				Check the piston for sticking or omission.	Check the piston for operation and replace the part.
Check the motor drain oil level.	Replace the motor.				
Malfunctioning of hoisting reduction gears	Malfunctioning of engine sensing	Check the system for unusual noise, abnormally high temperature and vibrations.	Replace the reduction gears.		
		Check the voltage of the engine rotation grip or rotating speed sensor.	Adjust the rotation grip L/H level or replace the rotation grip.		
		Check the voltage of the main pump solenoid proportional pressure reducing valve.	Adjust or replace the solenoid proportional pressure reducing valve.		

12. TROUBLESHOOTING

Portion in question	Symptom	Possible cause	Check points	Remedy	
Swing system	Swing is unavailable. Specified swing speed cannot be reached. There is no swing force.	Hydraulic oil is short.	Check the hydraulic oil tank oil level.	Replenish hydraulic oil.	
			Defective swing brake	Check the suction strainer for clogging.	Wash or replace the strainer.
				Check whether the swing brake release pressure is normal or not. Check whether the pressure switch operation is normal or not.	Repair the swing brake valve or replace the valve. Repair the pressure switch wiring or replace the switch.
		Malfunctioning of remote control valve	Check the brake disc for unusual noise and high temperature.	Check the brake disc or replace the disc.	
			Check whether the secondary pressure generation condition is normal.	Replace the spool or replace the valve.	
		Malfunctioning of remote control circuit relief valve	Check the primary pressure.	Regulate the primary pressure or replace the valve.	
			Check the function lock limit switch for operation.	Regulate operation of the limit switch or replace the limit switch.	
			Check the function lock solenoid valve for operation.	Regulate operation of the solenoid valve or replace the solenoid valve.	
		Defective swing control valve	Check the main valve relief pressure.	Regulate the relief valve pressure or replace the relief valve.	
			Check the valve spool for operation.	Lap or replace the spool.	
		Malfunctioning of swing motor	Check the piston for sticking or omission.	Check the piston for operation and replace the part.	
			Check the motor drain oil level.	Replace the motor.	
		Malfunctioning of swing reduction gears	Check the system for unusual noise, abnormally high temperature and vibrations.	Check the shaft and bearing for unusual noise and seizure.	
Check the gear oil level in the reduction gears.	Repair the shaft and bearing or replace parts. Replenish gear oil or replace parts.				
Malfunctioning of swing bearing	Check the system for unusual noise, abnormally high temperature and vibrations.	Check the bolt for loosening, the ball for problem and bearing for seizure.			
		Retighten the bolt, replace the ball and replace the bearing.			

Portion in question	Symptom	Possible cause	Check points	Remedy
Swing system	Swing is unavailable. Specified swing speed cannot be reached. There is no swing force.	Defective electrical system	Check the parking brake and the swing mode selector switch for operation.	Replace the switch or repair the wiring.
			Check the relay for switching and the contact for burn mark.	Replace the relay or repair the wiring.
			Check the swing mode selector solenoid valve for operation.	Replace the solenoid valve or repair the wiring.
			Check the system for unusual noise, abnormally high temperature and vibrations.	Check the bolt for loosening, the ball for problem and bearing for seizure. Retighten the bolt, replace the ball and replace the bearing.
	Shock action is seen at the occasions of start and stop of swing motion. Swing motion is not smooth.	Malfunctioning of swing bearing	Check the swing pinion for unusual noise and vibration.	Check the pinion for tooth contact condition, seizure and missing. Conduct lubrication, adjust the tooth contact or replace the pinion.
			Check whether the swing brake release pressure is normal or not.	Repair the swing brake valve or replace the valve.
	Defective swing brake		Check whether the pressure switch operation is normal or not.	Repair the pressure switch wiring or replace the switch.
			Check the brake disc for unusual noise and high temperature.	Check the brake disc or replace the disc.
			Check the primary pressure.	Regulate the primary pressure or replace the valve.
			Check the function lock limit switch for operation.	Regulate operation of the limit switch or replace the limit switch.
	Malfunctioning of remote control circuit relief valve		Check the function lock solenoid valve for operation.	Regulate operation of the solenoid valve or replace the solenoid valve.
			Check the main valve relief pressure.	Regulate the relief valve pressure or replace the relief valve.
	Defective swing control valve		Check the valve spool for operation.	Lap or replace the spool.
			Check the piston for sticking or omission.	Check the piston for operation and replace the part.
Malfunctioning of swing motor		Check the motor drain oil level.	Replace the motor.	

Portion in question	Symptom	Possible cause	Check points	Remedy
Swing system	Shock action is seen at the occasions of start and stop of swing motion. Swing motion is not smooth.	Malfunctioning of swing reduction gears	Check the system for unusual noise, abnormally high temperature and vibrations.	Check the shaft and bearing for unusual noise and seizure.
			Check the gear oil level in the reduction gears.	Repair the shaft and bearing or replace parts.
		Defective electrical system	Check the parking brake and the swing mode selector switch for operation.	Replace the switch or repair the wiring.
			Check the relay for switching and the contact for burn mark.	Replace the relay or repair the wiring.
			Check the swing mode selector solenoid valve for operation.	Replace the solenoid valve or repair the wiring.
			Check whether the swing brake release pressure is normal or not.	Repair the swing brake valve or replace the valve.
			Check whether the pressure switch operation is normal or not.	Repair the pressure switch wiring or replace the switch.
			Check the brake disc for unusual noise and high temperature.	Check the brake disc or replace the disc.
			Check the parking brake and the swing mode selector switch for operation.	Replace the switch or repair the wiring.
			Check the relay for switching and the contact for burn mark.	Replace the relay or repair the wiring.
Propelling system	Propelling is unavailable. Specified propelling speed cannot be reached. There is no propelling force.	Hydraulic oil is short.	Check the swing mode selector solenoid valve for operation.	Replace the solenoid valve or repair the wiring.
			Check the hydraulic oil tank oil level.	Replenish hydraulic oil.
		Malfunctioning of remote control valve	Check the suction strainer for clogging.	Wash or replace the strainer.
			Check whether the secondary pressure generation condition is normal.	Replace the spool or replace the valve.
			Adjust the secondary pressure detection switch.	Replace the pressure switch.
			Check the primary pressure.	Regulate the primary pressure or replace the valve.
			Check the function lock limit switch for operation.	Regulate operation of the limit switch or replace the limit switch.
			Check the function lock solenoid valve for operation.	Regulate operation of the solenoid valve or replace the solenoid valve.
			Check the main valve relief pressure.	Regulate the relief valve pressure or replace the relief valve.
			Defective propelling control valve	

Portion in question	Symptom	Possible cause	Check points	Remedy
Propelling system	Propelling is unavailable. Specified propelling speed cannot be reached.	Malfunctioning of propel motor	Check the piston for sticking or omission.	Check the piston for operation and replace the part.
		There is no propelling force.	Check the motor drain oil level.	Replace the motor.
	Shock action is seen at the occasions of start and stop of propelling motion.	Malfunctioning of propel gears	Check the system for unusual noise, abnormally high temperature and vibrations.	Check the shaft and bearing for unusual noise and seizure.
		Poor engagement of shoe with tumbler	Check the gear oil level in the reduction gears.	Repair the shaft and bearing or replace parts.
	Propelling motion is not smooth.	Defective propelling brake	Check engagement of the shoe with the tumbler as well as running on.	Replenish gear oil or replace parts.
			Check whether the propelling brake release pressure is normal or not.	Adjust tension of the shoe, repair the shoe or replace parts.
			Check whether the pressure switch operation is normal or not.	Repair the propelling brake valve or replace the valve.
			Check the brake disc for unusual noise and high temperature.	Repair the pressure switch wiring or replace the switch.
	Malfunctioning of remote control circuit relief valve	Defective propelling control valve	Look into the brake valve.	Check the brake disc or replace the disc.
			Check the primary pressure.	Replace the brake valve.
			Check the function lock limit switch for operation.	Regulate the primary pressure or replace the valve.
			Check the function lock solenoid valve for operation.	Regulate operation of the limit switch or replace the limit switch.
			Check the main valve relief pressure.	Regulate operation of the solenoid valve or replace the solenoid valve.
			Check the valve spool for operation.	Regulate the relief valve pressure or replace the relief valve.
	Malfunctioning of propel motor	Malfunctioning of propel motor	Check the piston for sticking or omission.	Lap or replace the spool.
			Check the motor drain oil level.	Check the piston for operation and replace the part. Replace the motor.

Portion in question	Symptom	Possible cause	Check points	Remedy
Propelling system	Shock action is seen at the occasions of start and stop of propelling motion. Propelling motion is not smooth.	Malfunctioning of propel reduction gears	Check the system for unusual noise, abnormally high temperature and vibrations.	Check the shaft and bearing for unusual noise and seizure.
			Check the gear oil level in the reduction gears.	Repair the shaft and bearing or replace parts.
	Defective electrical system		Check the fuse (F-15) for blowing as well as wiring.	Replenish gear oil or replace parts.
			Check the propelling brake and low and high speed selector switch for operation.	Replace the fuse (F-15) or repair the wiring.
			Check the relay for switching and the contact for burn mark.	Replace the switch or repair the wiring.
			Check the propelling brake and low and high speed selector solenoid valve for operation.	Replace the relay or repair the wiring.
	Propelling brake went out.	Defective propelling brake	Check whether the propelling brake release pressure is normal or not.	Replace the solenoid valve or repair the wiring.
			Check whether the pressure switch operation is normal or not.	Repair the propelling brake valve or replace the valve.
		Check the brake disc for unusual noise and high temperature.	Repair the pressure switch wiring or replace the switch.	
		Look into the brake valve.	Check the brake disc or replace the disc.	
Check the propelling brake and low and high speed selector switch for operation.		Replace the brake valve.		
Check the relay for switching and the contact for burn mark.		Replace the switch or repair the wiring.		
Check the propelling brake and low and high speed selector solenoid valve for operation.	Replace the relay or repair the wiring.			
		Replace the solenoid valve or repair the wiring.		